



US 20140163382A1

(19) **United States**

(12) **Patent Application Publication**
Gubbini et al.

(10) **Pub. No.: US 2014/0163382 A1**

(43) **Pub. Date: Jun. 12, 2014**

(54) **ULTRASOUND APPARATUS COVER**

(75) Inventors: **Alessandro Gubbini**, State College, PA (US); **Bradley Nelson**, Boalsburg, PA (US)

(73) Assignee: **SOUND TECHNOLOGY INC.**, State College, PA (US)

(21) Appl. No.: **14/234,063**

(22) PCT Filed: **Jul. 22, 2011**

(86) PCT No.: **PCT/US2011/044798**

§ 371 (c)(1),
(2), (4) Date: **Jan. 21, 2014**

Publication Classification

(51) **Int. Cl.**
A61B 8/00 (2006.01)

(52) **U.S. Cl.**

CPC **A61B 8/4422** (2013.01)
USPC **600/461; 600/459; 53/428; 156/247**

(57) **ABSTRACT**

An ultrasound transducer cover (100) includes a base (202), including an acoustically transmissive membrane (110) with first and second opposing sides. The cover further includes walls (204, 206) protruding from the base in a same direction away from the first side of the base, forming a cavity about the acoustically transmissive membrane with a geometry that conforms to a geometry of a probe head of an ultrasound apparatus housing a transducer array and a corresponding acoustic window. The cover further includes an acoustically transmissive adhesive (108) disposed on the membrane in the cavity, wherein the acoustically transmissive adhesive maintains the cover on the ultrasound apparatus in response to installing the cover on the ultrasound apparatus.

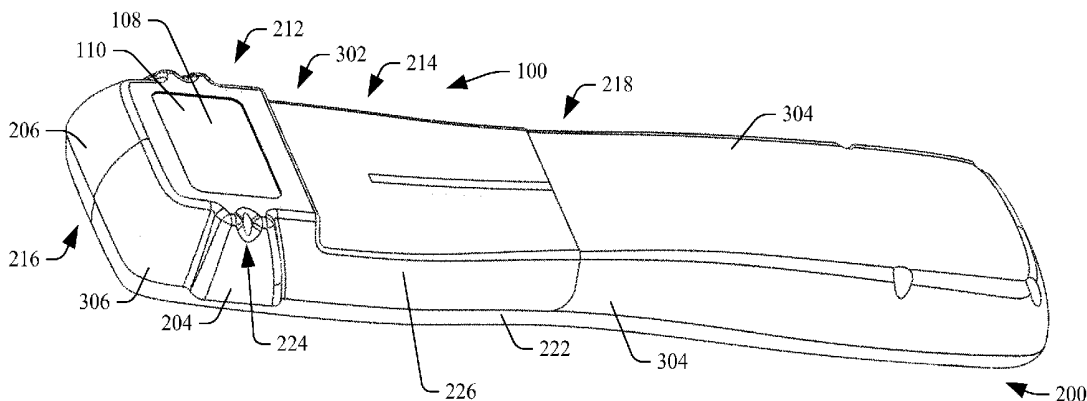

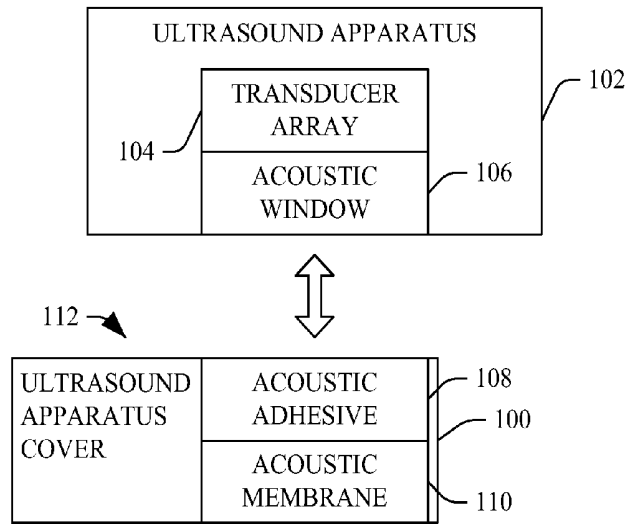

FIGURE 1

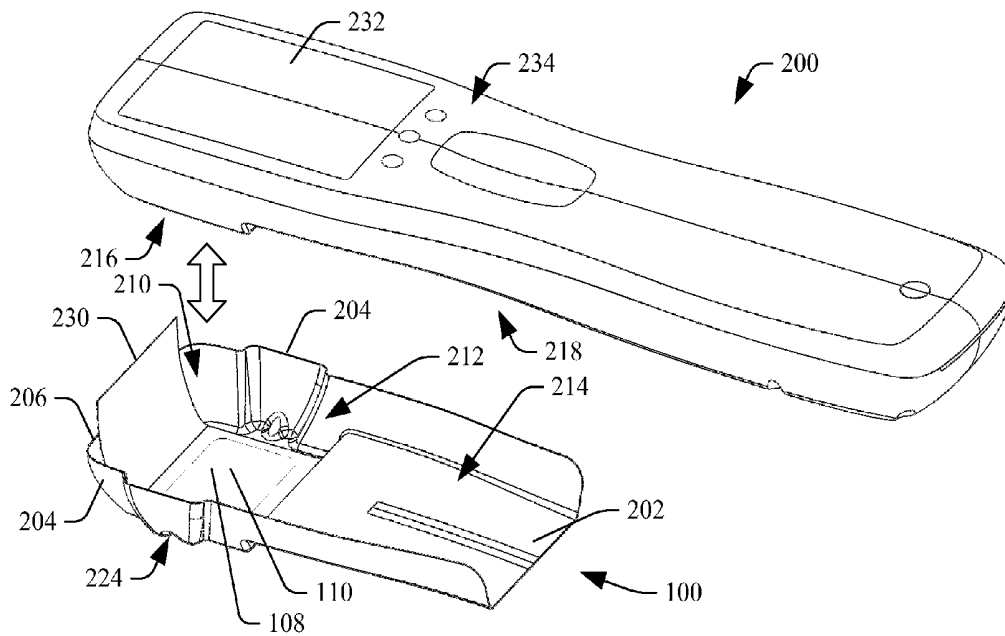

FIGURE 2

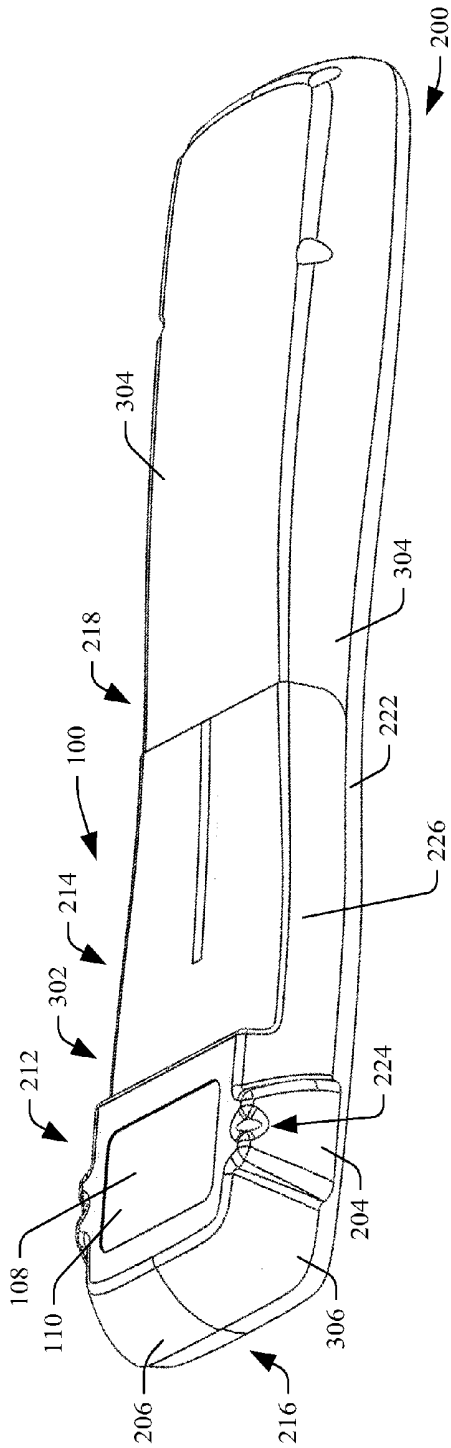

FIGURE 3

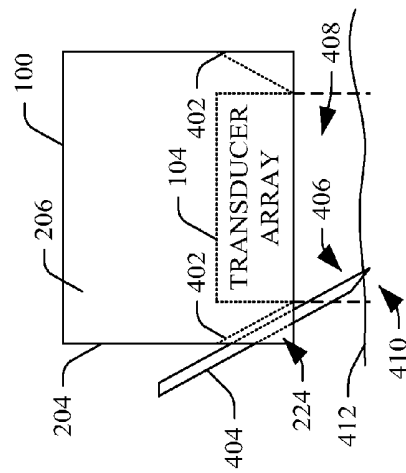

FIGURE 4

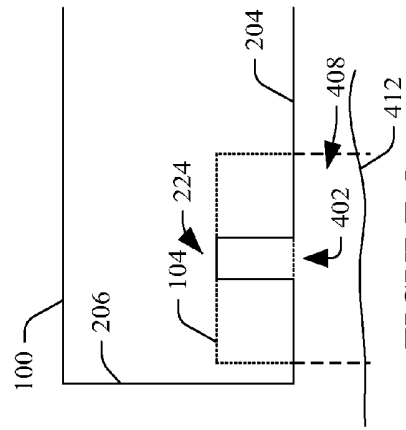

FIGURE 5

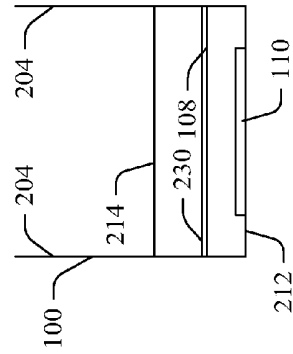

FIGURE 6

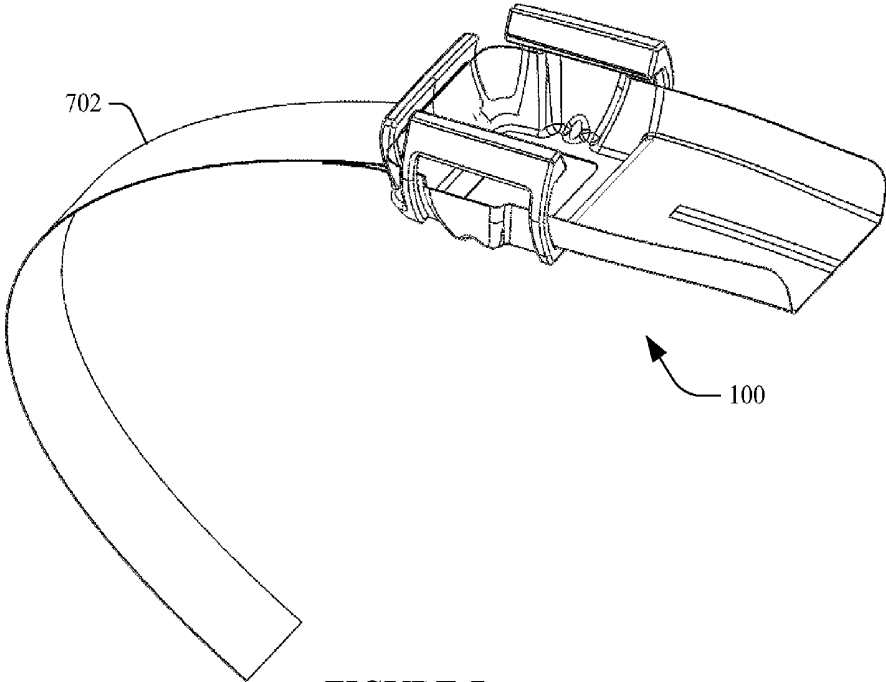

FIGURE 7

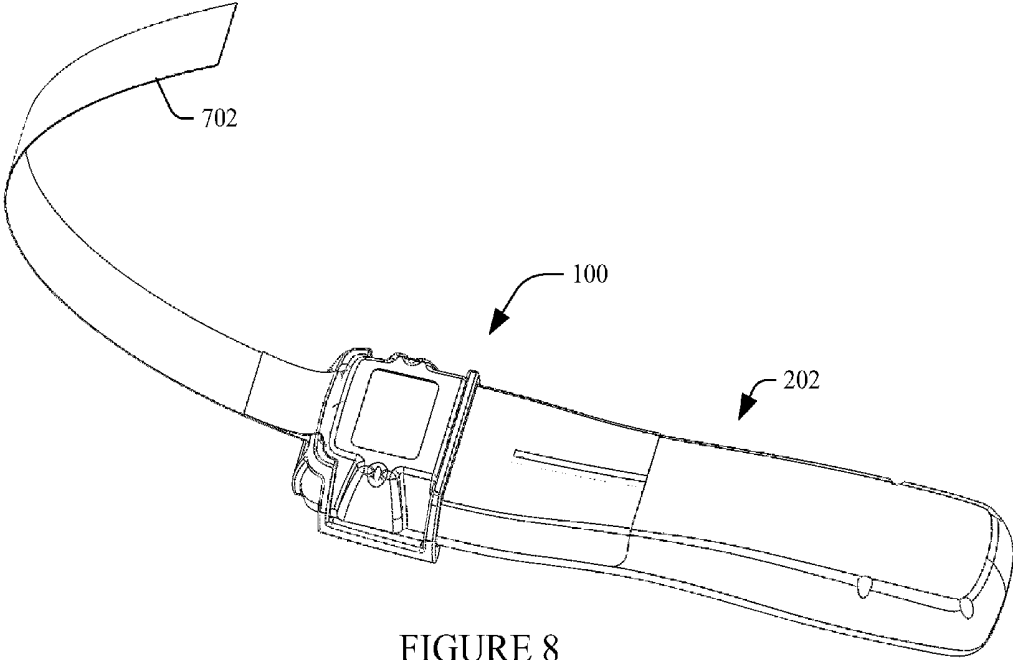

FIGURE 8

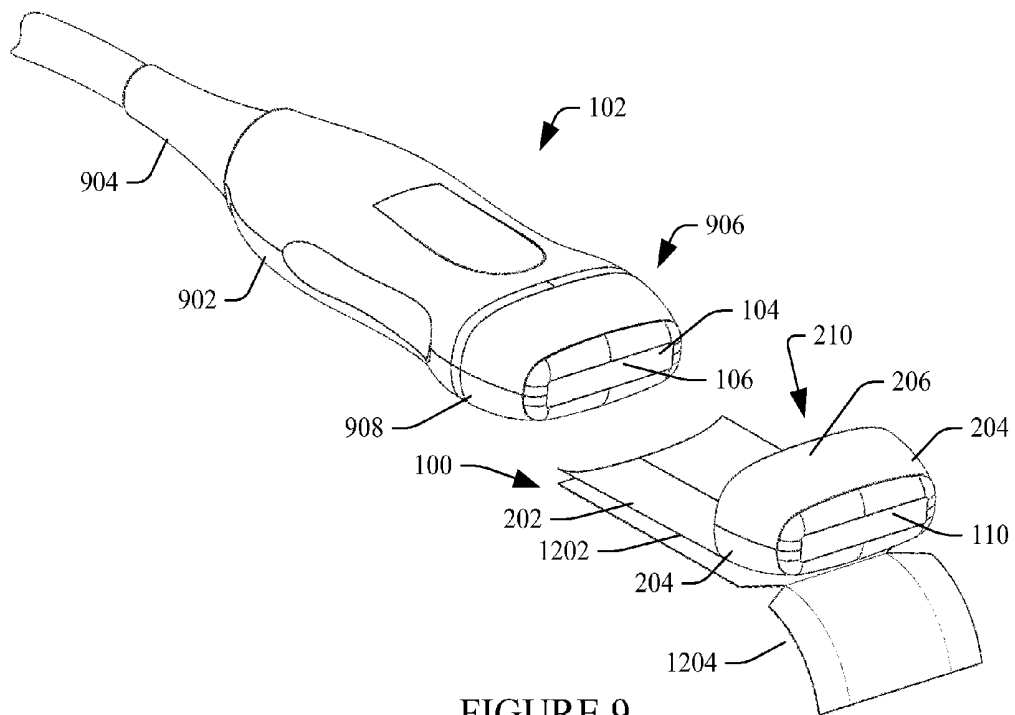

FIGURE 9

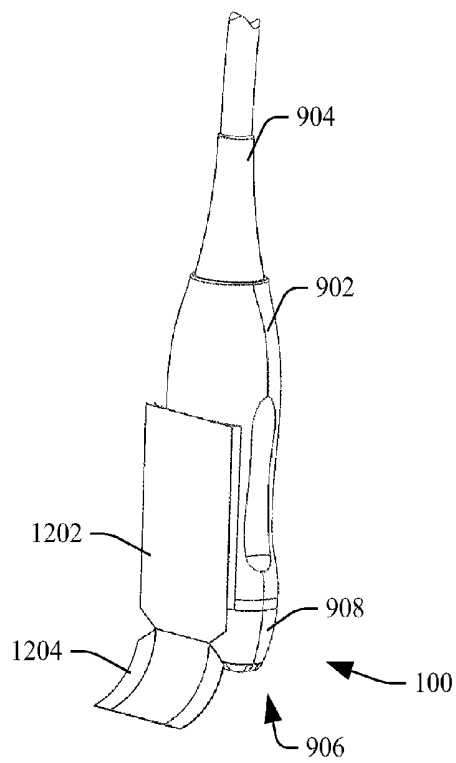

FIGURE 10

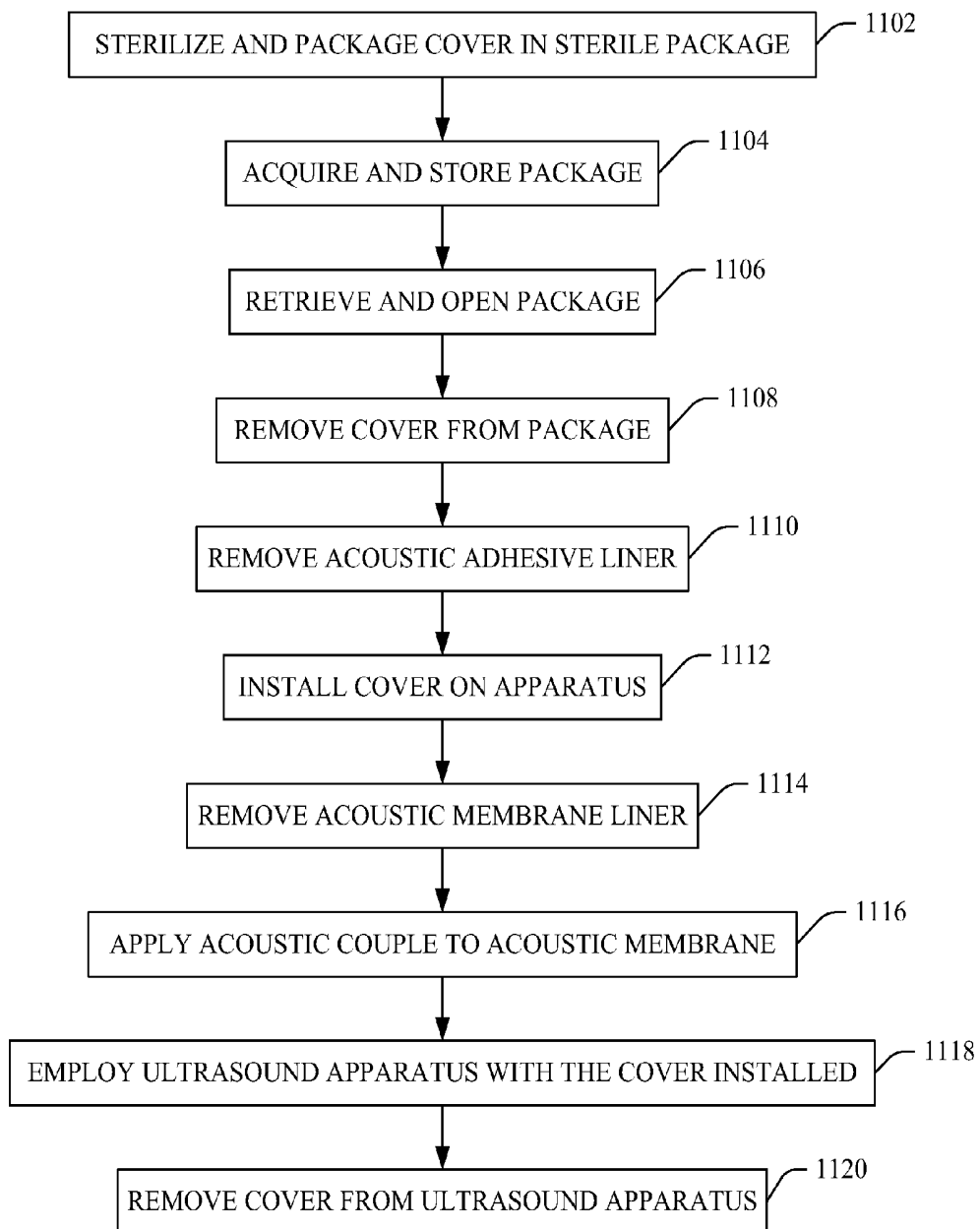

FIGURE 11

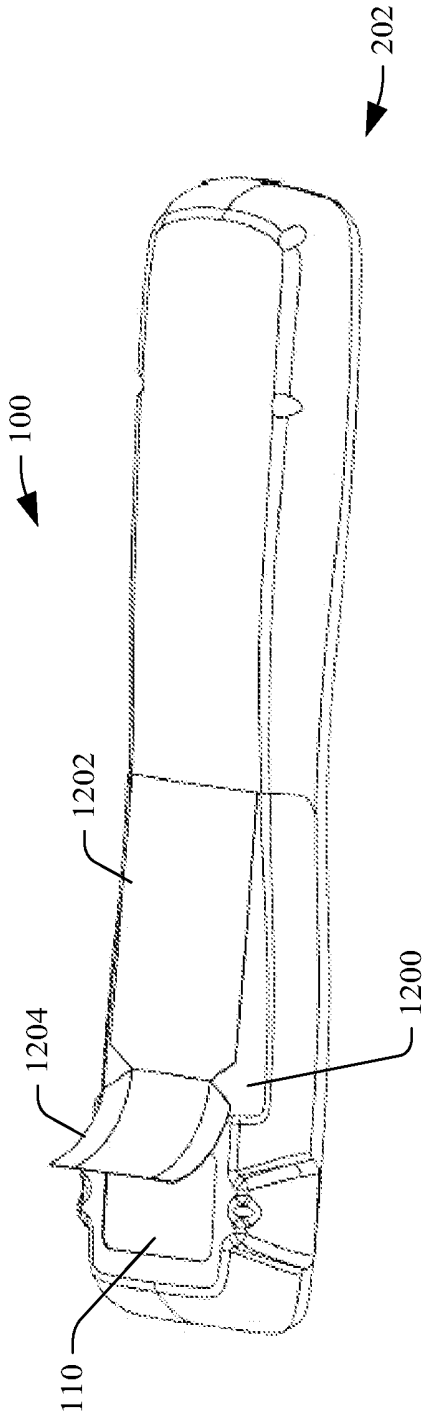

FIGURE 12

ULTRASOUND APPARATUS COVER

TECHNICAL FIELD

[0001] The following generally relates to ultrasound imaging and more particularly to a medical ultrasound transducer array cover.

BACKGROUND

[0002] Ultrasound scanners provide useful information about the interior characteristics of an object under examination. In medical applications, clinicians have used ultrasound scanners to examine human subjects in settings such as hospitals, physician's offices, and other locations. Ultrasound scanners have been used in the emergency room, operating room, radiology department, patient room, and/or other environments. In use, an acoustic coupling agent, typically a lubricious gel largely composed of water and propylene glycol, is placed on the acoustic window/lens of the ultrasound transducer array and/or an area of the patient in connection with the region of interest to be scanned. The user then positions the transducer array with respect to the area of the patient. The gel between the acoustic window and the area provides an acoustic medium that facilitates transferring ultrasound signals there between. The ultrasound scanner can then be used to scan the region of interest.

[0003] In some environments (e.g., sterile environments), transducer covers are used. Transducer covers conventionally have included a rubber or thin plastic bag or sheath that physically surrounds and encloses the entire or a sub-portion of the probe. When a cover is used an acoustic coupling agent is required both between the transducer and cover and between the cover and the patient. Such covers are supplied sterilized in sterile packaging (e.g., U.S. Pat. No. 3,754,700) and may come prefilled with a coupling gel and/or other coupling agent. Other covers are not pre-filled, and the user adds gel into the bag prior installing on the transducer. The user also applies the gel on the outside of the cover and/or on the area of the patient. Other covers have included cup-shaped covers that snap on the probe (e.g., U.S. Pat. No. 6,132,378) and self-adhesive thin pliable film dressings that are wrapped around and adhere to the probe (e.g., U.S. 2006/0264751 A1). Unfortunately, such covers can be cumbersome to install and use.

[0004] Procedures such as biopsies, peripheral intravenous insertions (PIVs), and/or other procedures which involve use of a needle entail employing a separate needle guide apparatus with the probe or a needle guide accessory that attaches to the probe. Generally, such needle guides have been configured to constrain a needle in a fixed path (plane and/or insertion angle), for example, that is in the middle of elevation of the acoustic beam (traditional single plane transducer) represented by a guide line on the ultrasound system. A typical needle guide has two main components: a reusable bracket that snaps on the probe and is placed under the cover (where a cover is used), and a disposable guide that attaches from outside the cover. Unfortunately, such assembly may not be easy to install and may require more than one person to maintain sterility during cover and/or needle guide installation in a sterile environment, and may be too restrictive for PIV. Furthermore, for certain procedures such as peripheral intravenous insertions, the size of the sterile field is limited to a small area directly around the insertion site and a cover that encloses the entire transducer may provide more coverage

than is required. Moreover, traditional ultrasound gel is not well-suited for ultrasound guided peripheral intravenous insertions, for example, because of post needle insertion cleanup in preparation for application of dressings over the catheter.

SUMMARY

[0005] Aspects of the application address the above matters, and others.

[0006] In one aspect, an ultrasound transducer cover includes a base, including an acoustically transmissive membrane with first and second opposing sides. The cover further includes walls protruding from the base in a same direction away from the first side of the base, forming a cavity about the acoustically transmissive membrane with a geometry that conforms to a geometry of a probe head an ultrasound apparatus housing a transducer array and a corresponding acoustic window. The cover further includes an acoustically transmissive adhesive disposed on the base in the cavity. The acoustically transmissive adhesive maintains the cover on the ultrasound apparatus in response to installing the cover on the ultrasound apparatus.

[0007] In another aspect, a method includes obtaining an ultrasound transducer cover. The cover includes a base with an acoustically transmissive membrane with first and second opposing sides. The cover further includes walls protruding from the base in a same direction away from the first side of the base, forming a cavity about the acoustically transmissive membrane with a geometry that conforms to a geometry of a probe head an ultrasound apparatus housing a transducer array and a corresponding acoustic window. The cover further includes an acoustically transmissive adhesive disposed on the base in the cavity. The cover further includes an adhesive liner removeably affixed to the acoustically transmissive adhesive. The method further includes removing the adhesive liner from the acoustically transmissive adhesive. The method further includes installing the cover on the probe head by physically contacting the acoustically transmissive adhesive with the acoustically transmissive window of the ultrasound apparatus. The acoustically transmissive adhesive maintains the cover on the ultrasound apparatus in response to installing the cover on the ultrasound apparatus.

[0008] In another aspect, a method includes obtaining an ultrasound transducer cover. The cover includes a base with an acoustically transmissive membrane with first and second opposing sides. The cover further includes walls protruding from the base in a same direction away from the first side of the base, forming a cavity about the acoustically transmissive membrane with a geometry that conforms to a geometry of a probe head an ultrasound apparatus housing a transducer array and a corresponding acoustic window. The cover further includes an acoustically transmissive adhesive disposed on the base in the cavity. The method further includes installing a removable adhesive liner to cover the acoustically transmissive adhesive. The method further includes packaging the cover with the liner in a container.

[0009] Those skilled in the art will recognize still other aspects of the present application upon reading and understanding the attached description.

BRIEF DESCRIPTION OF THE DRAWINGS

[0010] The application is illustrated by way of example and not limitation in the figures of the accompanying drawings, in which like references indicate similar elements and in which:

[0011] FIG. 1 schematically illustrates an example cover for an ultrasound apparatus;

[0012] FIGS. 2 and 3 illustrate an example cover for a hand held single enclosure ultrasound scanner;

[0013] FIGS. 4 and 5 illustrate an example needle guide of the cover;

[0014] FIG. 6 illustrates an example in which the cover includes an acoustically transmissive adhesive with a removable liner;

[0015] FIGS. 7 and 8 illustrate a variation of the cover of FIGS. 2 and 3 in which the cover includes a strap for holding the transducer in place on a patient;

[0016] FIGS. 9 and 10 illustrate an example cover for a probe configured to be connected to an ultrasound scanner console via a cable;

[0017] FIG. 11 illustrates an example method for the cover; and

[0018] FIG. 12 illustrates an optional integrated gel dispense and an optional liner for covering the outside of the acoustically transmissive membrane.

DETAILED DESCRIPTION

[0019] FIG. 1 schematically illustrates an ultrasound apparatus cover 100 in connection with an ultrasound apparatus 102. In this example, the ultrasound apparatus 102 includes at least a transducer array 104 and an acoustic window/lens 106 located at a region of the ultrasound apparatus 102 configured to be placed in contact with an object or structure to scan a portion of the object or structure. As described in greater detail below, the ultrasound apparatus 102 may be part of a single enclosure hand held ultrasound scanner, a transducer probe configured to connect to a separate ultrasound console via a cable or the like, and/or other ultrasound apparatus 102.

[0020] The ultrasound apparatus cover 100 includes an acoustically transmissive membrane 110 and an acoustically transmissive adhesive 108, which is affixed thereto. The acoustically transmissive membrane 110 can include a plastic, a rubber and/or other material, including, but not limited to, a water based or an alcohol based liquid or gel, and/or a semi-rigid pad. In one embodiment, the acoustically transmissive membrane 110 provides a barrier that inhibits pathogens from migrating from one side of the membrane to the other side. The acoustically transmissive adhesive 108 is located in connection with a first side 112 of the ultrasound apparatus cover 100, and the acoustically transmissive membrane 110 is located adjacent thereto and in connection with a second opposing side 114 of the ultrasound apparatus cover 100, which opposes the first side 112. The acoustically transmissive adhesive 108 can be any type of adhesive with suitable acoustic coupling characteristics such as alcohol, water, oil, etc. based and/or other acoustically transmissive adhesive in the form of a liquid, a gel, a semi-rigid gel pad, a tape, a rigid material, and/or other form. The acoustically transmissive adhesive 108 and the acoustically transmissive membrane 110 are arranged with respect to each other in the ultrasound apparatus cover 100 such that the acoustically transmissive adhesive 108 and the acoustically transmissive membrane 110 are in mechanical contact and acoustically coupled.

[0021] The ultrasound apparatus cover 100 is generally rigid and pre-formed (e.g., thermo, injection mold, or otherwise formed) so that the first side geometrically conforms to a shape of at least a portion of the ultrasound apparatus 102 that includes the acoustic window/lens 106, before and after

installing the cover 100 on the apparatus 102. In one instance, this includes configuring at least the shape of the ultrasound apparatus cover 100 so that the acoustically transmissive adhesive 108 and acoustically transmissive membrane 110 are positioned to align with the acoustic window 106 and hence the transducer array 104 when the cover 100 is installed on the apparatus 102. Suitable cover materials include plastic, cardboard, paper, metal, and/or other materials. In one instance, the material has a thickness in a range of about five thousandths of an inch to about forty thousandths of an inch such as twenty thousandths of an inch. Where the cover material includes a cardboard, paper or the like, the cover 100 can be laminated, coated and/or otherwise protected with a water resistant material. Optionally, the base, walls and acoustically transmissive membrane are monolithic and made of a thermoplastic material.

[0022] The acoustically transmissive adhesive 108, when placed in physical contact with the ultrasound apparatus 102, adheres to the acoustic window/lens 106 of the ultrasound apparatus 102, maintaining installation of the cover 100 with the apparatus 102. The acoustically transmissive adhesive 108 and the acoustically transmissive membrane 110 are arranged in the ultrasound apparatus cover 100 so that acoustically transmissive membrane 110 aligns with the acoustic window/lens 106 when the cover 100 is installed on the apparatus 102. In such a configuration, the acoustically transmissive adhesive 108 and the acoustically transmissive membrane 110 provide an acoustic medium between the transducer array 104 and the portion of the object or subject being scanned. In one instance, the acoustically transmissive adhesive 108 can be any suitable adhesive strength that allows the cover 100 to stay in place during use for scanning, but for purposes of disposal of the cover, is reasonably easily to release without damage to the ultrasound apparatus 102 or acoustic window/lens 106.

[0023] The ultrasound apparatus cover 100 may be disposable, cleanable, disinfected, re-usable, and/or sterilizable. Where the ultrasound apparatus cover 100 is disinfected and/or sterilized, the ultrasound apparatus cover 100 may provide a sonographer or other user of the ultrasound apparatus 102 a quick way of rendering the side 106 of the ultrasound apparatus 102 sterile. In this instance, the ultrasound apparatus cover 100 may also be packaged in a sterile package.

[0024] Optionally, the ultrasound apparatus cover 100 includes physical features for various functions such as to guide a needle for needle access procedures such as biopsies or peripheral IV line placements, to secure the ultrasound apparatus 102 in a desired position without human intervention, to apply an acoustic couplant between the cover 100 and the patient for scanning, and/or other physical features.

[0025] FIGS. 2 and 3 illustrate a non-limiting example of the ultrasound apparatus cover 100 where the ultrasound apparatus 102 includes an ultrasound scanner 200 configured as a hand held single enclosure. In FIG. 2, the cover 100 is not installed on the ultrasound scanner 200, and in FIG. 3 the cover 100 is installed on the ultrasound scanner 200.

[0026] Initially referring to FIG. 2, the cover 100 includes a base 202, first and second opposing side walls 204, and a front wall 206. The walls 204 and 206 protrude from the base 202 in a same direction, thereby forming an open cavity 210 defined by the base 202 and the walls 204 and 206, with an open side, which opposes the front wall 206, and an open side, which opposes the base 202.

[0027] A first portion 212 of the base 202 is located adjacent to the front wall 206 and a second portion 214 of the base 202 extends from the first portion 212 in a direction away from the front wall 206. The first portion 212 is recessed with respect to the second portion 212 and includes the acoustically transmissive membrane 110.

[0028] The first portion 212 has a geometrical shape that conforms substantially to a shape of a probe head 216 of the ultrasound scanner 200, which houses the transducer array 104 and acoustic window 106 (FIG. 1). The second portion 214 has a geometrical shape that conforms substantially to a shape of a handle portion 218 of the ultrasound scanner 200. In this embodiment, a length of the second portion 214 is less than a length of the handle portion 218. In other embodiments, the length of the second portion 214 can be larger or smaller, or the second portion 214 can be omitted.

[0029] A removable liner 230 is located in the cavity 210 and is used to cover the acoustically transmissive adhesive 108. The liner 230 is removed before installing the ultrasound apparatus cover 100 on the ultrasound scanner 200. In FIG. 2, the removable liner 230 is shown extending past the front wall 206 to enable easy grasping by the user. In this embodiment the liner 230 is completely removed from the cover 100. In other embodiments the liner could be folded to a position where it does not interfere with scanning with the ultrasound scanner 200.

[0030] FIG. 3 shows the cover 100 from a backside 302 of the base 202, which faces away from the cavity 210. As shown in FIG. 3, the walls 204 cover side walls 304 of the ultrasound scanner 200, the front wall 206 covers a front wall 306 of the ultrasound scanner 200, the first portion 212 of the base 202 rests against the probe head 216, the second portion 214 of the base 202 rests against the handle portion 218, and the acoustically transmissive membrane 110 adheres to the window portion 106 of the probe head 216 of the ultrasound scanner 200 via the acoustically transmissive adhesive 108.

[0031] In FIGS. 2 and 3, the cover 100 also includes a needle guide 224, which is located in connection with the walls 204. For sake of clarity, the needle guide 224 is discussed in connection with FIGS. 4 and 5, which respectively show a block diagram representation of the ultrasound apparatus cover 100 looking into the front wall 206 (FIG. 4) and looking into one of the side walls 204 (FIG. 5).

[0032] In FIGS. 4 and 5, the needle guide 224 includes a channel 402 which is configured to guide (e.g., provide a centerline), but not constrain, a needle 404 along a path for freehand or other insertion. The channel 402 is configured so that a tip region 406 of the needle 404 can be readily positioned in an imaging region 408 of the transducer array 104 between the transducer array 104 and a region 410 of a subject 412 where the needle is inserted. With a conventional single plane transducer, this may include guiding the needle 404 in the middle of elevation of the imaging region 408.

[0033] FIG. 4 shows a configuration with two needle guides 224, one on each of the two side walls 204. Other embodiments may include no, one, or more than two needle guides 224. In yet another embodiment, a needle guide 224 is additionally or alternatively located with respect to the front wall 206 and/or other location. Note that the size, shape and relative position of the components in FIGS. 4 and 5 are for explanatory purposes and are not limiting.

[0034] With continuing reference to FIGS. 2 and 3 and with reference to FIG. 6, a block diagram looking into the front wall 206 of the cover 100 and showing the acoustically trans-

missive adhesive 108 in the first portion 212 is illustrated. In this embodiment, the acoustically transmissive adhesive 108 is a pre-applied liquid or gel acoustic adhesive. In another instance, the acoustically transmissive adhesive 108 is a semi-rigid double-sided adhesive gel pad. In yet another instance, the acoustically transmissive adhesive 108 includes a plurality of sheets material. The liner 230 is shown removeably affixed over the acoustically transmissive adhesive 108 and is removed before installing the cover 100 on the ultrasound scanner 200.

[0035] In FIGS. 2 and 3, the ultrasound scanner 200 is a hand held ultrasound scanner housed in a single enclosure. As such, the scanner 200 includes, in addition to the transducer array 104, a transducer array controller (not visible), an image processor (not visible), a display 232, and a user interface 234. The transducer array 104 includes a one-dimensional and/or a two-dimensional array of transducer elements arranged in a linear, curved, circular, or other manner, and is configured to acquire data for A-mode, B-mode, C-mode, etc. acquisitions, individually and in combination with color flow, Doppler flow, and/or other information.

[0036] The transducer array controller includes transmit and receive circuitry and a switch that switches between transmit and receive circuitry. Generally, the transmit circuitry controls actuation of the transducer elements, which allows for steering and/or focusing the transmitted beam from predetermined origins along the array and at predetermined angles, and the receive circuitry's various processes receive echoes and generates and outputs a processed signal. In one non-limiting instance, the receive circuitry delays and sums received echoes, generating a focused signal for a single line through a scanned region of interest. Other suitable processing includes, but is not limited to, spatial compounding, filtering (e.g., FIR, IIR, etc.), and/or other processing.

[0037] The image processor includes one or more processors that convert the signal from the transducer controller to generate data for display, for example, by converting the data to the coordinate system of the display. The display 232 can be used to present the converted data. By way of non-limiting example, in one mode, the display can present a plane of a vessel that is parallel to a bottom or transducer array and that shows the interior of the vessel along the long axis of the vessel, including a portion of the needle 404 within the displayed interior of the vessel, when the needle 404 is inserted into the vessel.

[0038] The user interface 234 includes various input and/or output devices for interacting with the transducer controller, for example, to select a data processing and presentation mode, a data acquisition mode, initiate scanning, etc. The user interface 234 may include various controls such as buttons, knobs, a keypad, a touch screen, etc. The user interface 234 may also include various types of visual (e.g., LCD, LED, etc.) and/or audible feedback.

[0039] Variations and/or other embodiments are contemplated.

[0040] FIG. 12 shows an embodiment in which the ultrasound apparatus cover 100 also includes a support region 1200 where a packet 1202 of acoustic coupling material can be removeably affixed. Various approaches can be used to affix the packet 1202 to the support region 1200. For example, an adhesive may be applied to the region 1200 and/or the packet 1202, and this adhesive can be used to affix the packet 1202 to the region 1200. In another example, the region 1200 may include a pocket in which the packet 1202 can be inserted

into. Other approaches are also contemplated herein. In the illustrated embodiment, a removable tab **1204** is torn off and removed prior to the packet **1202** being squeezed to apply an acoustic coupling material to the exterior of acoustic membrane **110**. In another embodiment, the support **1200** and packet **1202** are omitted, and an acoustic couplant such as a hydrogel pad is integrated with the membrane **110**.

[0041] In another embodiment, the removable tab **1204** additionally comprises a removable sterile liner **1204** that covers surfaces that are intended to remain sterile such as the acoustic membrane **110** of the side that contacts the patient. The liner **1204** can be removed before, during or after installing the ultrasound apparatus cover **100** on the ultrasound scanner **200**, but before scanning. In FIG. **12**, the removable liner **1204** is shown partially folded back and partially removed. The liner **1204** can be completely removed from the cover **100** or folded to a position where it does not interfere with scanning with the ultrasound scanner **200**. In another embodiment this sterile liner **1204** may be a separate feature from the packet **1202** and/or there may be no packet.

[0042] FIGS. **7** and **8** show a variation in which the ultrasound apparatus cover **100** further includes a strap **702**. In this example, the strap **702** is affixed at the front wall **206** of the cover **100**. In other embodiments, the strap **702** can be elsewhere affixed to the cover **100**. The strap **702** can include various materials such as rubber, plastic, leather, etc. The strap **702** can be used for various reasons. For example, in one instance the strap **702** is used to secure the ultrasound scanner **200** in position with respect to the region of the subject or object being scanned. This may include wrapping or tying the strap around a fixture or device in the examination room. In this manner, the user of the ultrasound scanner **200** does not have to hold the ultrasound scanner **200** in position. This allows, for example, the user of the ultrasound scanner **200** to free up his hands, for example, so that the user can use both hands to insert a needle into the subject or object.

[0043] FIGS. **9** and **10** illustrate a non-limiting example in which the ultrasound apparatus **102** is a conventional ultrasound probe **902** that connects to a separate ultrasound console via an electrical cable interface **904**. This cable interface may or may be detachable from the console via an electrical connector. In this instance, the console includes the transducer array controller, the image processor, the display and a user interface. With the illustrated probe **902**, the transducer array **104** is located at an end **906** of the probe head **908**.

[0044] In this embodiment, the second portion **214** of the base **202** extends in the same direction as the walls **204** and **206**, and the open cavity **210** is defined by the first and second portions **214** and **214** of the base **202** and the walls **204** and **206**, with only the open side that opposes the base **202**. Likewise, the cover **100** is rigid and the cavity **210** is preformed and geometrically configured based on the geometry of the probe head **908**. Furthermore, the acoustically transmissive adhesive **108** (not visible) is in the cavity **210** next to the acoustically transmissive membrane **110** and adheres to the acoustic window **104** when the cover **100** is installed on the probe **902**, maintaining installation.

[0045] In this embodiment, the cover **100** also includes the packet of acoustic material **1202** affixed thereto which is discussed at least in connection with FIGS. **2** and **3**. In another instance, the packet **1204** is omitted. Unlike cover **100** in FIGS. **2** and **3**, the cover **100** in this embodiment does not include the needle guide **224** or the strap **702**. However, in other embodiments, the cover **100** for the probe **902** also

includes at least one of needle guide **224** or the strap **702**. Additionally or alternatively, a separate needle guide can be employed with the probe **902**.

[0046] Although two types of ultrasound apparatuses **102** are shown (FIGS. **2** and **3** and FIGS. **9** and **10**), it is to be understood that other types of ultrasound apparatuses **102** are also contemplated herein. In such other instance, the apparatus cover **100** can be configured based on the geometry of the particular ultrasound apparatus **102**, in accordance to the description herein and/or variants thereof. Moreover, in such instances one or more of the features (e.g., needle guide, strap, acoustic couplant dispenser, etc.) described herein can be included.

[0047] It is to be appreciated that the cover **100** can be sterilized and packaged for use in sterile environments and used in such an environment. FIG. **11** illustrates an example method of this.

[0048] It is to be understood that the following acts are provided for explanatory purposes and are not limiting. As such, one or more of the acts may be omitted, one or more acts may be added, one or more acts may occur in a different order (including simultaneously with another act), etc.

[0049] At **1102**, the cover **100** is sterilized and placed in sterilizable package, which is sealed and sterilized. This can be achieved by a manufacturer and/or any appropriate sterilization method (e.g., EtO, Gamma Ray, etc.).

[0050] At **1104**, the package is acquired by a health care facility and stored in a location that won't compromise the sterility of the cover **100**.

[0051] At **1106**, the package is retrieved and opened in a sterile environment.

[0052] At **1108**, the cover **100** is removed from the sterile package. This can be done via authorized personnel wearing sterile clothes, where the cover **100** is handled so as not to breach its sterility.

[0053] At **1110**, the inside adhesive liner **230** is removed. In instances where the cover **100** does not include the liner **230**, this act is omitted.

[0054] At **1112**, the cover **100** is installed on the ultrasound apparatus **102**. As described herein, this includes physically contacting the acoustically transmissive adhesive **108** with the acoustic window **106** of the ultrasound apparatus **102**, where the acoustically transmissive adhesive **108** holds the cover **100** in place.

[0055] At **1114**, the outside acoustically transmissive membrane liner **1204** is removed. In instances where the cover **100** does not include the liner **1204**, this act is omitted.

[0056] At **1116**, the packet **1202** is used to apply a sterile acoustic couplant on the acoustically transmissive membrane **110**. In instances where the cover **100** does not include the packet **1202**, the sterile acoustic couplant can be manually applied from a separate bottle/packet to the acoustically transmissive membrane **110** and/or object or subject.

[0057] At **1118**, the ultrasound apparatus **102** with the cover **100** installed thereon is used to perform an ultrasound procedure.

[0058] At **1120**, subsequent to imaging with the apparatus **102**, the cover **100** is removed from the ultrasound apparatus **102** and discarded or alternatively cleaned, disinfected, sterilized, etc.

[0059] The application has been described with reference to various embodiments. Modifications and alterations will occur to others upon reading the application. It is intended that the invention be construed as including all such modifi-

cations and alterations, including insofar as they come within the scope of the appended claims and the equivalents thereof.

1. An ultrasound transducer cover for a hand held single enclosure ultrasound scanner that includes a probe head with at least a transducer array and a corresponding acoustic window, the ultrasound transducer cover, comprising:

a base, including an acoustically transmissive membrane with first and second opposing sides;

walls protruding from the base in a same direction away from the first side of the base, forming an open cavity about the acoustically transmissive membrane with a geometry that approximately conforms to a geometry of the probe head of the hand held single enclosure ultrasound apparatus, which houses the transducer array and the corresponding acoustic window; and

an acoustically transmissive adhesive disposed on the membrane in the open cavity, wherein the acoustically transmissive adhesive maintains the cover on the hand held single enclosure ultrasound apparatus in response to installing the cover on the hand held single enclosure ultrasound apparatus.

2. The cover of claim 1, wherein the acoustically transmissive adhesive provides an acoustic medium for transmission of ultrasound signals between the acoustic window of the hand held single enclosure ultrasound apparatus and the acoustically transmissive membrane of the cover.

3. The cover of claim 1, wherein the acoustically transmissive membrane includes a plastic or rubber film.

4. The cover of claim 1, wherein the acoustically transmissive membrane is one of a water based or an alcohol based liquid or gel.

5. The cover of claim 1, wherein the acoustically transmissive membrane includes a semi-rigid pad.

6. The cover of claim 1, wherein the cover includes a rigid or semi-rigid material.

7. The cover of claim 1, wherein the base and walls are pre-formed to correspond to the geometry of the probe head of the hand held single enclosure ultrasound apparatus.

8. The cover of claim 1, wherein the base includes a non-acoustically transmissive membrane region with a geometry that conforms to a geometry of a handle portion of the hand held single enclosure ultrasound apparatus.

9. The cover of claim 1, wherein the walls form a closed wall around the acoustically transmissive membrane.

10. The cover of claim 1, wherein at least one of the walls incorporates at least one channel (402) configured to guide a needle being inserted into a region of an object or subject, wherein the channel guides the needle through a region located between the acoustically transmissive membrane and the region.

11. The cover of claim 1, wherein the base includes a cardboard or paper material.

12. The cover of claim 11, wherein the base material is laminated or coated with a water resistant material.

13. The cover of claim 1, wherein the base includes an injection molded material or thermoformed thermoplastic material.

14. The cover of claim 1, wherein the base, walls and acoustically transmissive membrane are monolithic and made of a thermoplastic material.

15. The cover of claim 1, further comprising:

an adhesive liner that is removeably affixed next to and covers a surface of the acoustically transmissive adhesive facing towards the acoustically transmissive membrane and into the cavity.

16. The cover of claim 1, wherein the acoustically transmissive adhesive is releasable from the ultrasound apparatus after use.

17. The cover of claim 1, further comprising:

a strap attached to the cover and configured to be secured to a static structure to maintain the cover, and hence the hand held single enclosure ultrasound apparatus, at a static position without human intervention.

18. The cover of claim 1, further comprising:

a support region on the second side of the acoustically transmissive membrane that is configured to support a container of an acoustic coupling medium.

19. The cover of claim 18, wherein the acoustic coupling medium is dispensed from the container and onto the acoustically transmissive membrane.

20. The cover of claim 1, wherein the cover is sterilized and packaged in a sterile kit for use in sterile environments.

21. The cover of claim 1, wherein the acoustically transmissive membrane provides a barrier that inhibits pathogens from migrating from the first to the second opposing sides.

22. A method, comprising:

obtaining an ultrasound transducer cover for a hand held single enclosure ultrasound scanner that includes a probe head with at least a transducer array and a corresponding acoustic window, the cover including:

a base, including an acoustically transmissive membrane with first and second opposing sides;

walls protruding from the base in a same direction away from the first side of the base, forming a cavity about the acoustically transmissive membrane with a geometry that conforms to a geometry of a the probe head of the ultrasound apparatus, which houses the transducer array and the corresponding acoustic window;

an acoustically transmissive adhesive disposed on the membrane in the cavity; and

an adhesive liner removeably affixed to the acoustically transmissive adhesive, and

removing the adhesive liner from the acoustically transmissive adhesive; and

installing the cover on the probe head by physically contacting the acoustically transmissive adhesive with the acoustic window of the ultrasound apparatus, wherein the acoustically transmissive adhesive maintains the cover on the ultrasound apparatus in response to installing the cover on the ultrasound apparatus.

23. The method of claim 22, the cover further including a liner which covers and is removeably affixed to an outside of the acoustically transmissive membrane and at least a portion of the transducer cover, and further comprising:

removing the membrane liner from the acoustically transmissive membrane and transducer cover.

24. The method of claim 22, the cover further including a support region supporting a container of acoustic coupling material, and further comprising:

dispensing the acoustic coupling material from the container and onto the acoustically transmissive membrane.

25. The method of claim 22, the cover further including a needle guide (224), and further comprising:

employing the needle guide to insert a needle into an object or subject being scanned.

26. The method of claim **22**, the cover further including a strap (**702**), and further comprising:

positioning the cover to position the ultrasound apparatus at a location of interest; and

affixing the strap to a static member to secure the cover at the location of interest, wherein the strap maintains the cover at the location of interest without a human holding the cover at the location of interest.

27. The method of claim **22**, further comprising:

removing the cover from a sterile package, wherein the cover is sterile.

28-29. (canceled)

30. A method, comprising:

obtaining an ultrasound transducer cover for a hand held single enclosure ultrasound scanner that includes a probe head with at least a transducer array and a corresponding acoustic window, the cover including:

a base, including an acoustically transmissive membrane with first and second opposing sides;

walls protruding from the base in a same direction away from the first side of the base, forming a cavity about the acoustically transmissive membrane with a geometry that conforms to a geometry of a the probe head of the ultrasound apparatus, which houses the transducer array and the corresponding acoustically transmissive window; and

an acoustically transmissive adhesive disposed on the membrane in the cavity;

installing a removable adhesive liner to cover the acoustically transmissive adhesive; and

packaging the cover with the liner in a container.

31. The method of claim **30**, wherein the cover and the liner are sterile.

32. The method of claim **30**, further comprising:

sterilizing the cover and the liner inside the container.

* * * * *

专利名称(译)	超声仪器盖		
公开(公告)号	US20140163382A1	公开(公告)日	2014-06-12
申请号	US14/234063	申请日	2011-07-21
[标]申请(专利权)人(译)	gubbini亚历山德罗 NELSON BRADLEY		
申请(专利权)人(译)	GUBBINI , ALESSANDRO NELSON , BRADLEY		
当前申请(专利权)人(译)	SOUND TECHNOLOGY INC.		
[标]发明人	GUBBINI ALESSANDRO NELSON BRADLEY		
发明人	GUBBINI, ALESSANDRO NELSON, BRADLEY		
IPC分类号	A61B8/00		
CPC分类号	A61B8/4422 A61B8/4281 A61B8/4455		
其他公开文献	US9980700		
外部链接	Espacenet USPTO		

摘要(译)

超声换能器盖 (100) 包括基座 (202) ， 基座 (202) 包括具有第一和第二相对侧的声透射膜 (110) 。 盖子还包括从基座沿远离基座的第一侧的相同方向突出的壁 (204,206) ， 围绕声透射膜形成腔，其几何形状符合超声探头的几何形状。装置包括换能器阵列和相应的声学窗口。盖子还包括设置在腔体中的膜上的声透射粘合剂 (108) ， 其中声学透射粘合剂响应于将盖子安装在超声设备上而将盖子保持在超声设备上。

