



US 20090082674A1

(19) **United States**

(12) **Patent Application Publication**  
**HIBI**

(10) **Pub. No.: US 2009/0082674 A1**

(43) **Pub. Date: Mar. 26, 2009**

(54) **ULTRASOUND DIAGNOSTIC APPARATUS**

(30) **Foreign Application Priority Data**

(75) **Inventor: Yasushi HIBI, Tokyo (JP)**

Sep. 21, 2007 (JP) ..... 2007-245785

**Publication Classification**

Correspondence Address:  
**SCULLY SCOTT MURPHY & PRESSER, PC**  
400 GARDEN CITY PLAZA, SUITE 300  
GARDEN CITY, NY 11530 (US)

(51) **Int. Cl.**  
*A61B 8/00* (2006.01)

(52) **U.S. Cl.** ..... 600/459

(57) **ABSTRACT**

An ultrasound diagnostic apparatus is an ultrasound diagnostic apparatus having a plurality of transducer groups with a simple apparatus configuration having a plurality of transducer groups which are provided at a distal end portion of a probe, and are configured by a plurality of transducers arranged in a circumferential form or an arc form having a same radius of curvature, and a common sound ray synthesis table storing control data of the respective transducer groups.

(73) **Assignee: OLYMPUS MEDICAL SYSTEMS CORP., Tokyo (JP)**

(21) **Appl. No.: 12/234,123**

(22) **Filed: Sep. 19, 2008**

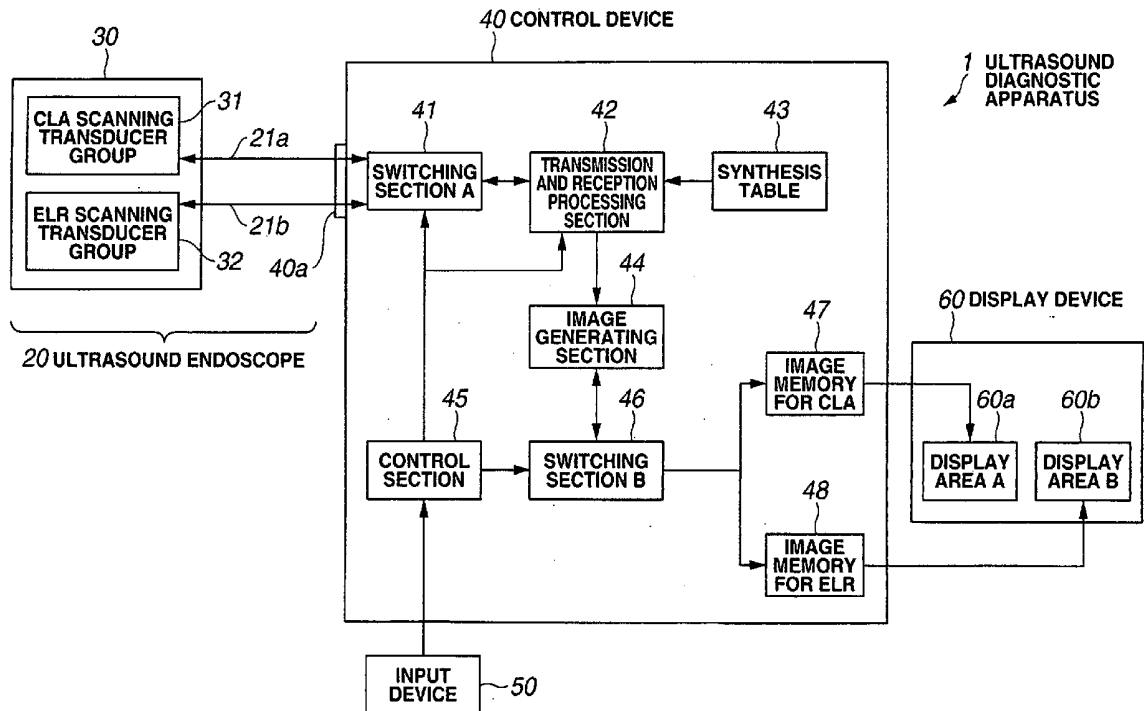
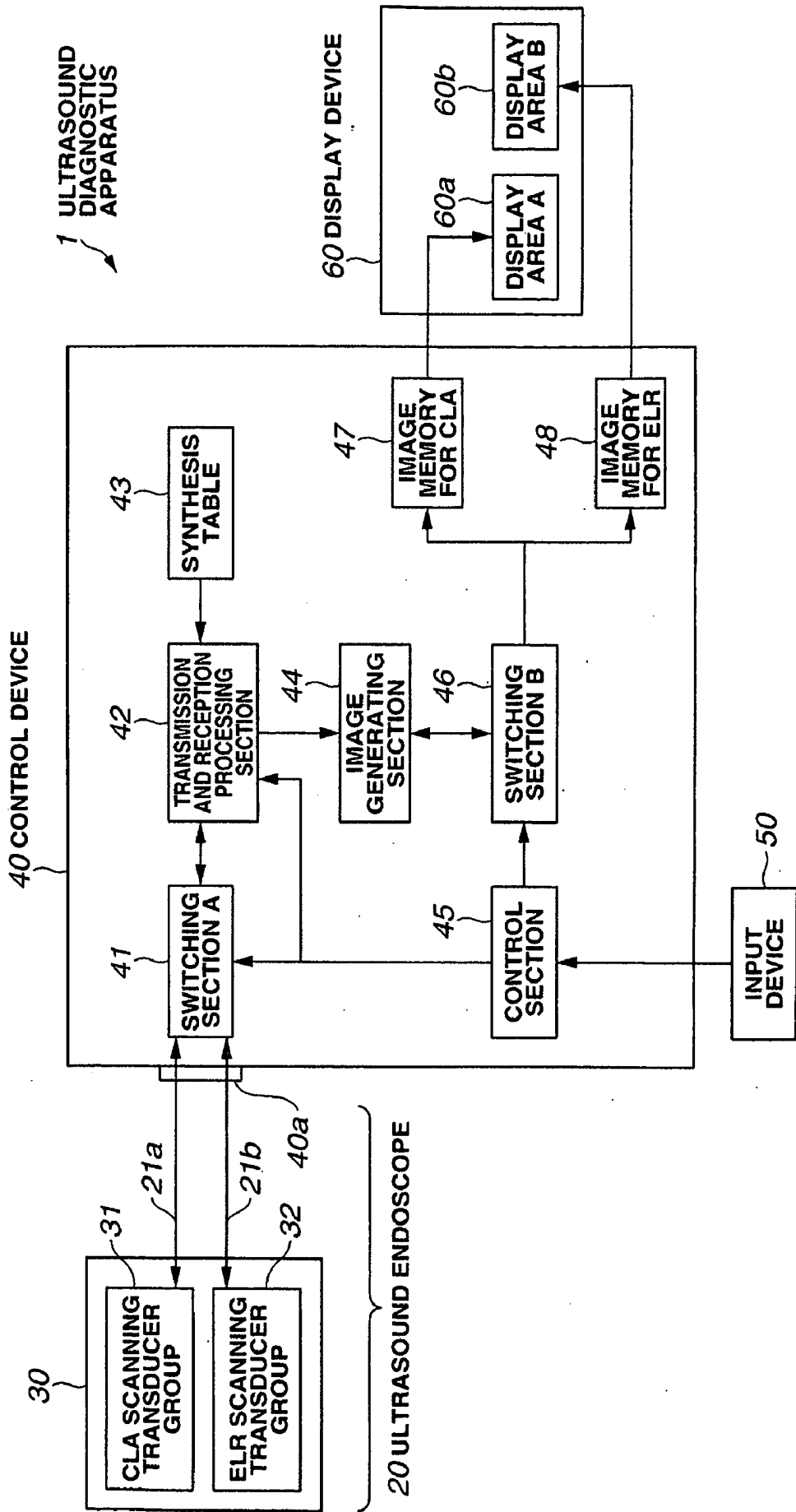
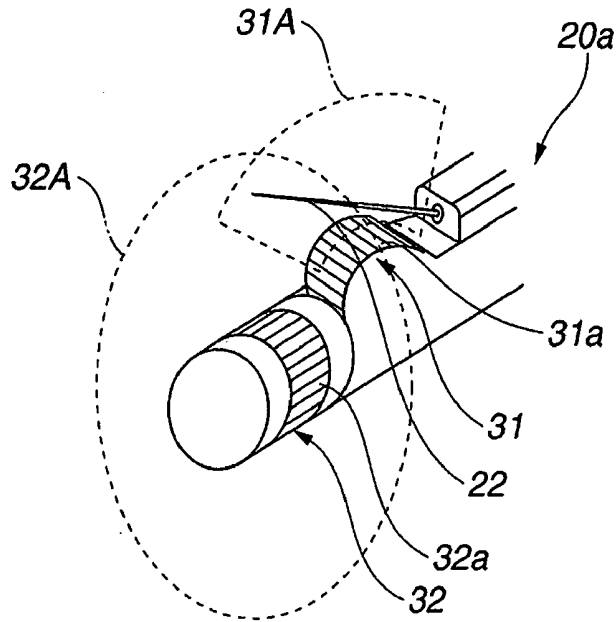

FIG.1



**FIG.2**



**FIG.3A**

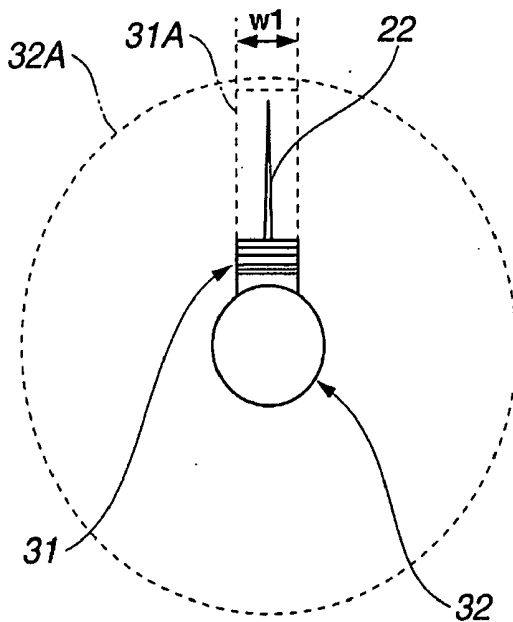

**FIG.3B**

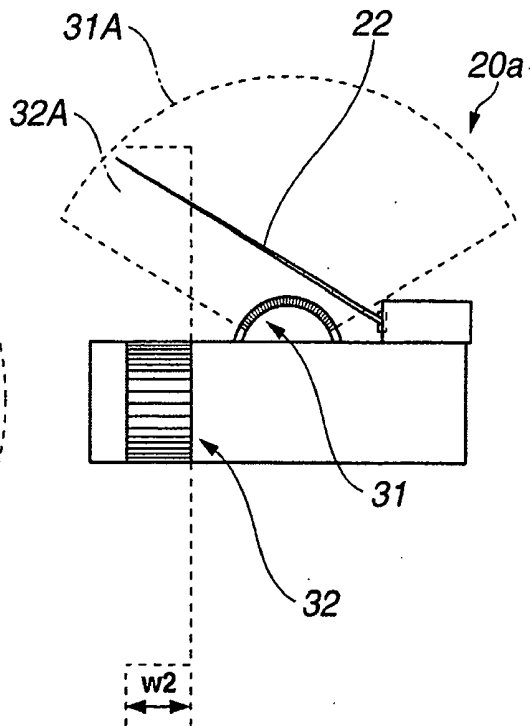

**FIG.4A**

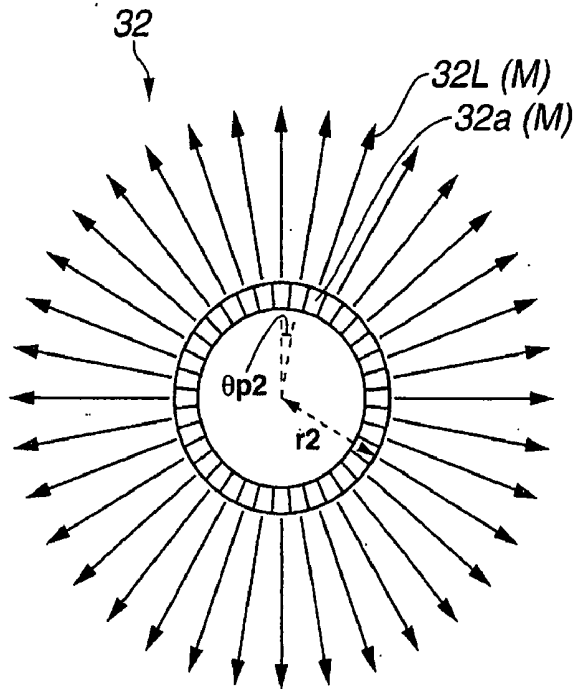

**FIG.4B**

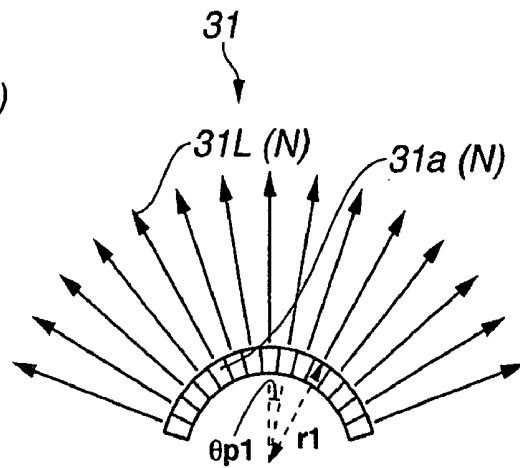

**FIG.5A**

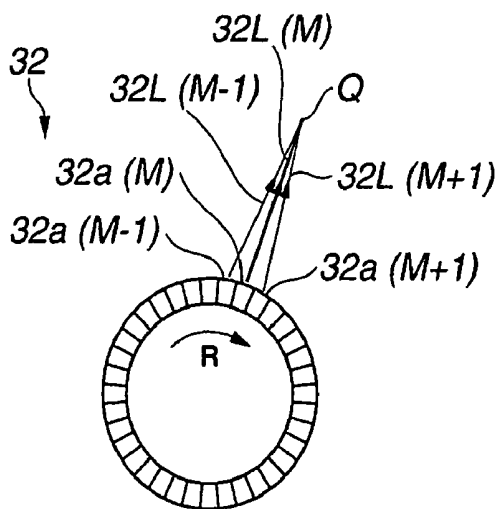

**FIG.5B**

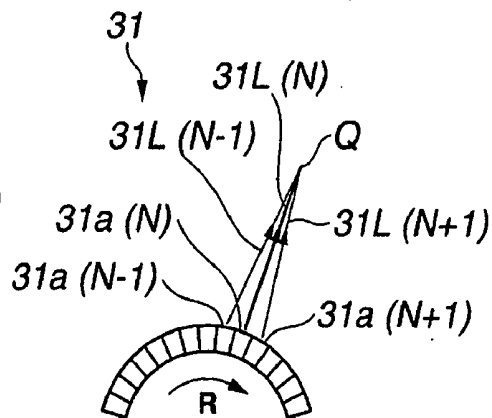

**FIG.6**

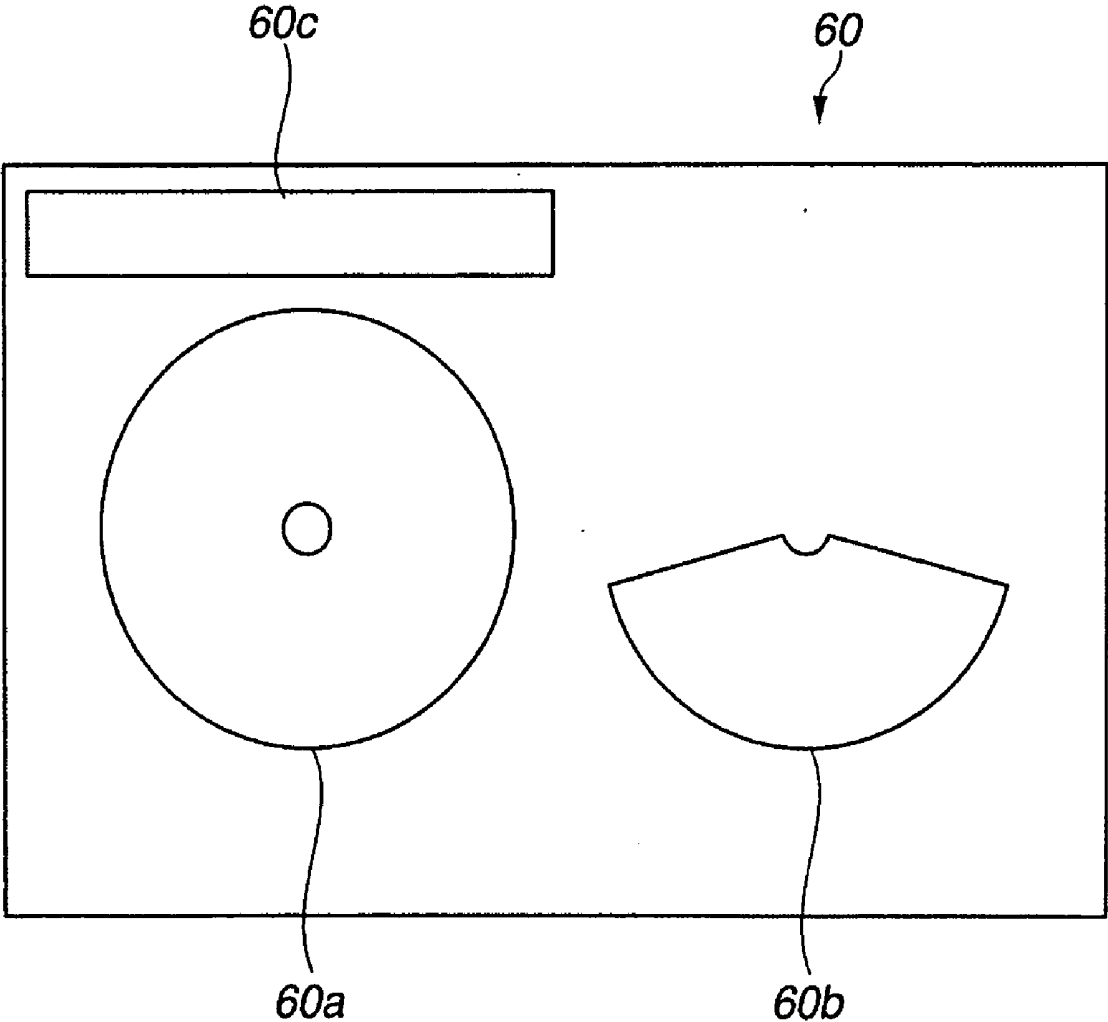
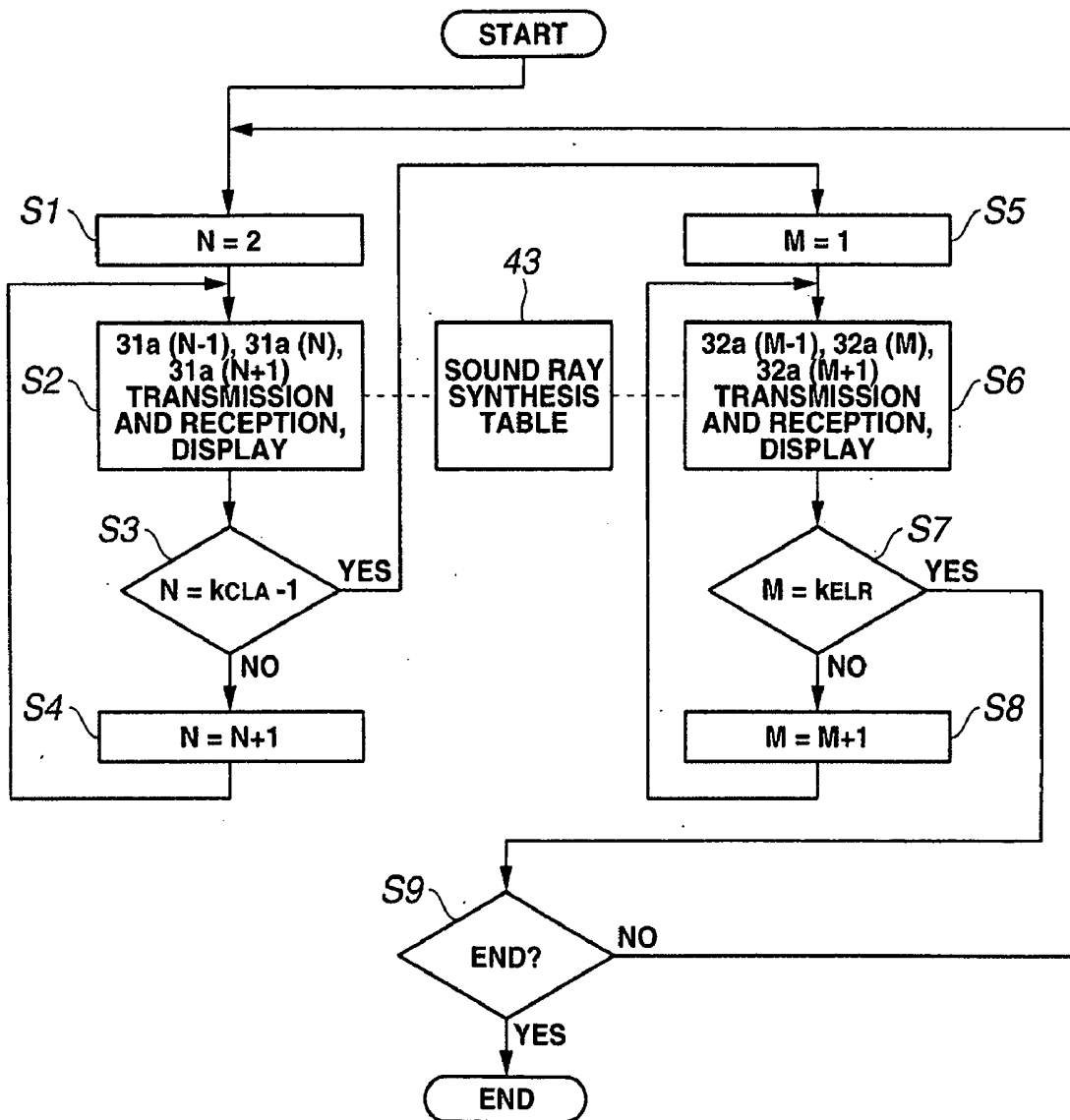
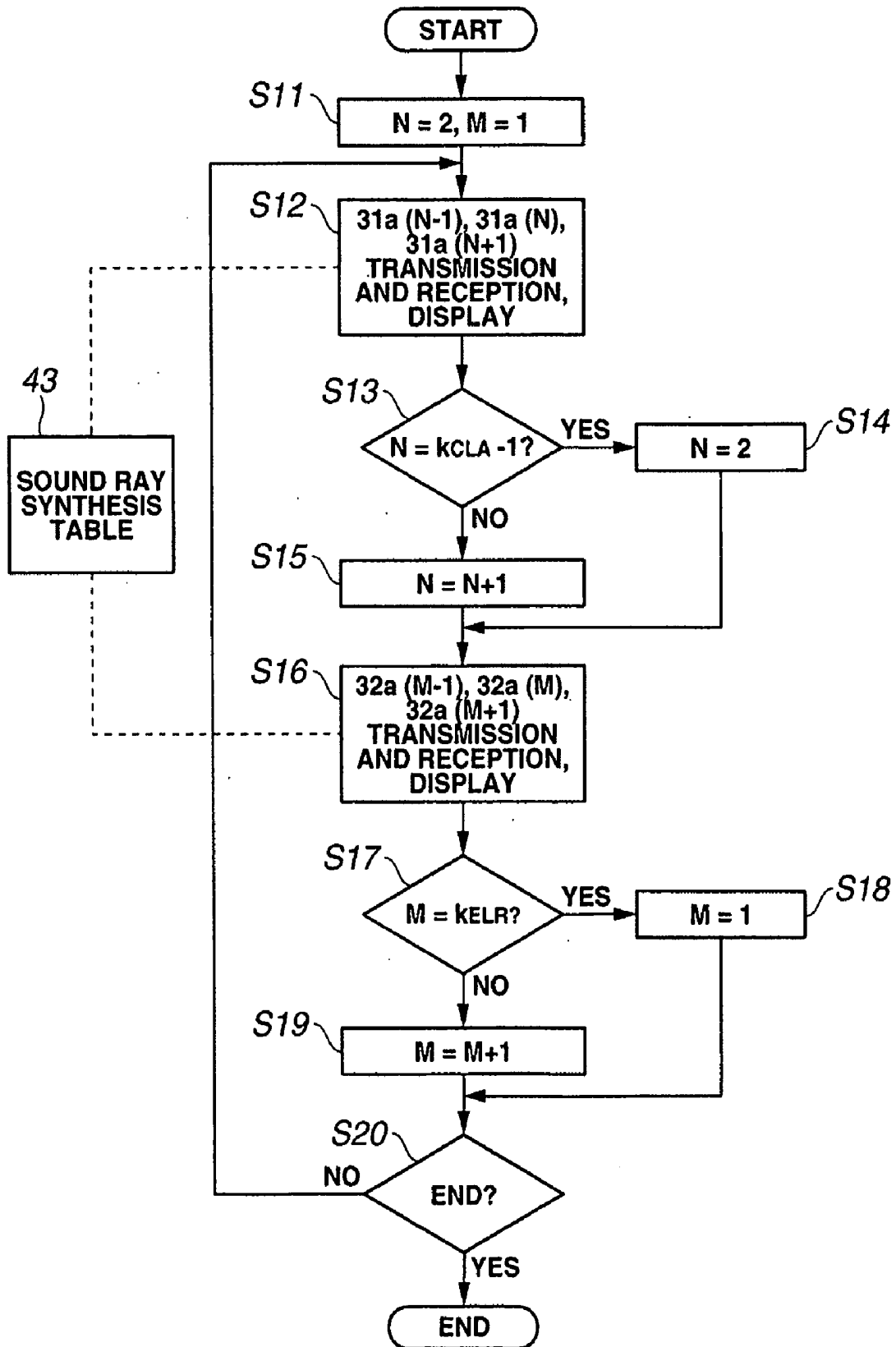

FIG.7



**FIG.8**



**FIG.9A**

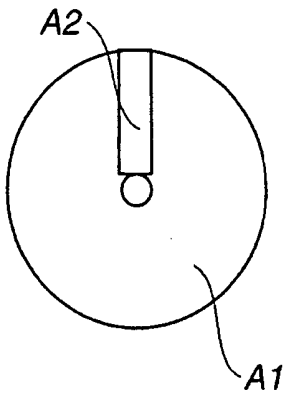

**FIG.9B**

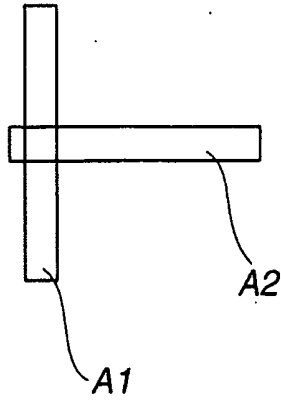

**FIG.9C**

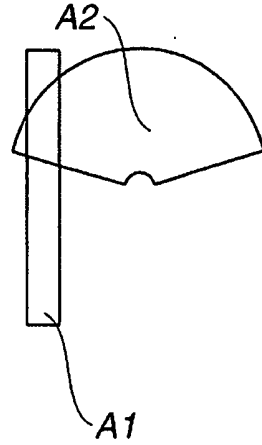

**FIG.10A**

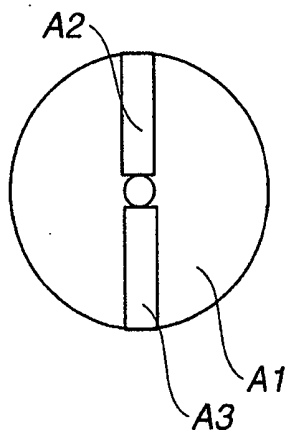

**FIG.10B**

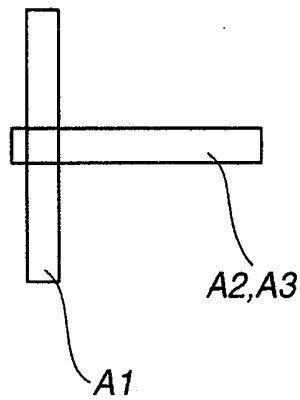

**FIG.10C**

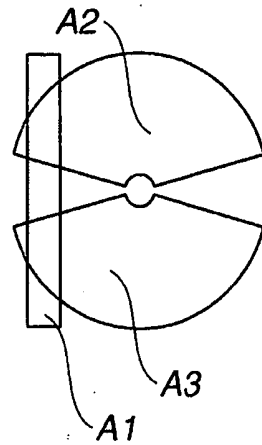

**FIG.11A**

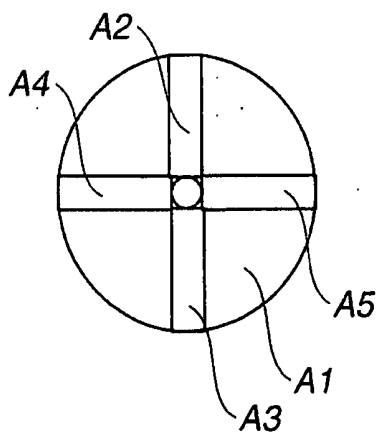

**FIG.11B**

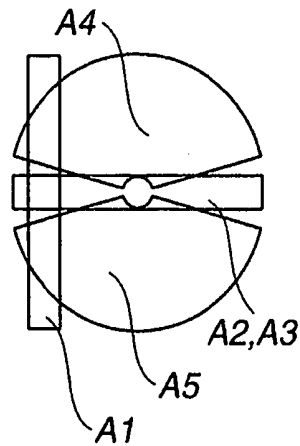

**FIG.11C**

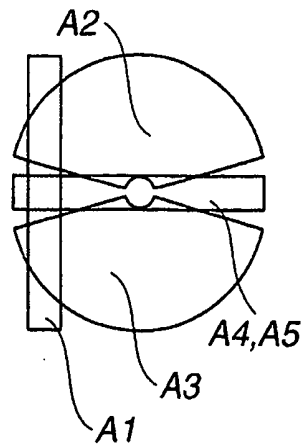
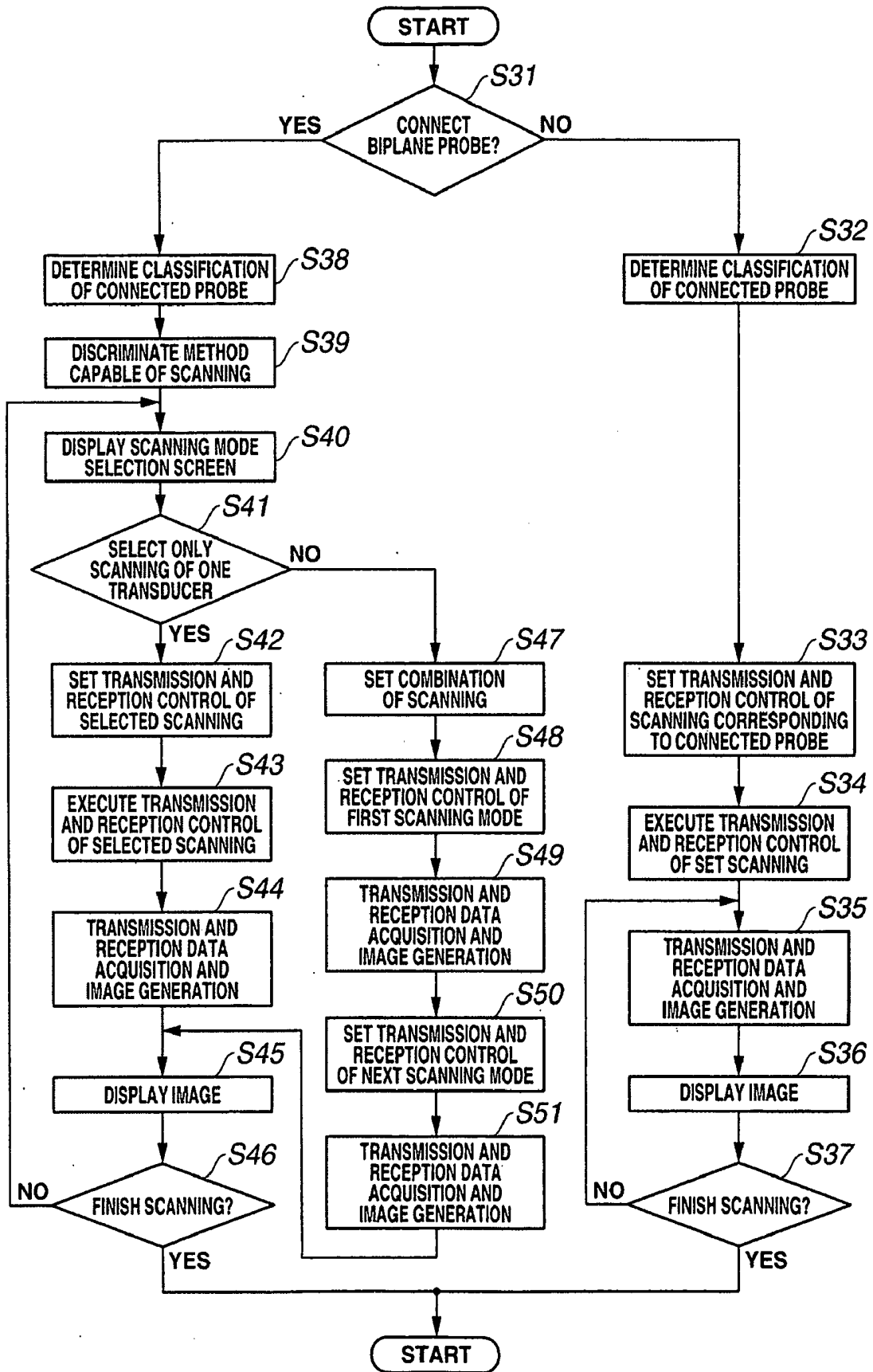

FIG.12



## ULTRASOUND DIAGNOSTIC APPARATUS

[0001] This application claims benefit of Japanese Patent Application No. 2007-245785 filed on Sep. 21, 2007, the contents of each of which are incorporated by this reference.

### BACKGROUND OF THE INVENTION

[0002] 1. Field of the Invention

[0003] The present invention relates to an ultrasound diagnostic apparatus, and particularly relates to an ultrasound diagnostic apparatus including an ultrasound endoscope having a plurality of transducer groups at a distal end portion of a probe.

[0004] 2. Description of the Related Art

[0005] In recent years, a method has become widespread, in which an ultrasound endoscope is inserted into a living body, a lesion in the body is found from its optical image, the lesion is irradiated with ultrasound, and an ultrasound tomogram of the lesion is diagnosed from the reflected wave. Further, a method is carried out, in which a cell is aspirated by being punctured while being visually recognized under guide of an optical image/ultrasound tomogram with use of a puncture needle, and confirmed diagnosis is performed by the aspirated cell.

[0006] When the diagnosis is carried out, a tissue needs to be accurately extracted. As an extraction method, there are a method in which a needle is inserted into a tumor under B mode guide of the ultrasound image and the tumor is reliably extracted, and the like. In this case, in order to diagnose a lesion in a lumen such as an inside of a body, radial scanning capable of scanning a whole of the inside of the lumen is suitable at first. An operator diagnoses the lesion by using a radial scanning intracavitary ultrasound endoscope. In order to carry out confirmed diagnosis after the position of the lesion is confirmed, the lesion needs to be searched for again with a convex scanning intracavitary ultrasound endoscope, and the convex scanning intracavitary ultrasound endoscope is inserted into a patient again. Accordingly, the patient needs to swallow the intracavitary ultrasound endoscope twice, and the patient is compelled to suffer pain.

[0007] Therefore, each of Japanese Patent Application Laid-Open Publication No. 8-56948 and Japanese Patent Application Laid-Open Publication No. 2004-135693 discloses a biplane ultrasound endoscope in which a transducer group for radial scanning and a transducer group for convex scanning are disposed close to each other at a probe so that scanning directions intersect each other. According to the ultrasound endoscope, sectional images in different directions can be observed with one scope.

[0008] Further, Japanese Patent Application Laid-Open Publication No. 2002-177278 discloses an ultrasound diagnostic apparatus in which a probe having three transducers is used, and a transducer switching circuit for switching a transducer for use is included so that the respective transducers share a transmission and reception section.

### SUMMARY OF THE INVENTION

[0009] In order to attain the above-described object, an ultrasound diagnostic apparatus of the present invention has a plurality of transducer groups which are provided at a distal end portion of a probe, and are configured by a plurality of transducers arranged in a circumferential form or an arc form

having a same radius of curvature, and a common sound ray synthesis table which stores control data of the respective transducer groups.

### BRIEF DESCRIPTION OF THE DRAWINGS

[0010] FIG. 1 is a configuration diagram of an ultrasound diagnostic apparatus according to an embodiment of the present invention;

[0011] FIG. 2 is a perspective view of a probe distal end portion according to the embodiment of the present invention;

[0012] FIG. 3A is a front view of the probe distal end portion according to the embodiment of the present invention;

[0013] FIG. 3B is a side view of the probe distal end portion according to the embodiment of the present invention;

[0014] FIG. 4A is a sectional view showing sound rays of an ELR scanning transducer group according to the embodiment of the present invention;

[0015] FIG. 4B is a sectional view showing sound rays of a CLA scanning transducer group according to the embodiment of the present invention;

[0016] FIG. 5A is a sectional view showing sound ray synthesis of the ELR scanning transducer group according to the embodiment of the present invention;

[0017] FIG. 5B is a sectional view showing sound ray synthesis of the CLA scanning transducer group according to the embodiment of the present invention;

[0018] FIG. 6 is a display example of ultrasound images displayed on a display device according to the embodiment of the present invention;

[0019] FIG. 7 is a flowchart of scanning of each transducer configuring the transducer groups according to the embodiment of the present invention;

[0020] FIG. 8 is a flowchart of scanning of each transducer configuring the transducer groups according to the embodiment of the present invention;

[0021] FIG. 9A is a view showing a scanning surface in an ultrasound diagnostic apparatus having two transducer groups scanning within surfaces orthogonal to each other according to the embodiment of the present invention;

[0022] FIG. 9B is a view showing a scanning surface in the ultrasound diagnostic apparatus having the two transducer groups scanning within the surfaces orthogonal to each other according to the embodiment of the present invention;

[0023] FIG. 9C is a view showing a scanning surface in the ultrasound diagnostic apparatus having the two transducer groups scanning within the surfaces orthogonal to each other according to the embodiment of the present invention;

[0024] FIG. 10A is a view showing a scanning surface in an ultrasound diagnostic apparatus having three transducer groups scanning within surfaces orthogonal to one another according to the embodiment of the present invention;

[0025] FIG. 10B is a view showing a scanning surface in the ultrasound diagnostic apparatus having the three transducer groups scanning within the surfaces orthogonal to one another according to the embodiment of the present invention;

[0026] FIG. 10C is a view showing a scanning surface in the ultrasound diagnostic apparatus having the three transducer groups scanning within the surfaces orthogonal to one another according to the embodiment of the present invention;

[0027] FIG. 11A is a view showing a scanning surface in an ultrasound diagnostic apparatus having five transducer

groups scanning within the surfaces orthogonal to one another according to the embodiment of the present invention;

[0028] FIG. 11B is a view showing a scanning surface in the ultrasound diagnostic apparatus having the five transducer groups scanning within the surfaces orthogonal to one another according to the embodiment of the present invention;

[0029] FIG. 11C is a view showing a scanning surface in the ultrasound diagnostic apparatus having the five transducer groups scanning within the surfaces orthogonal to one another according to the embodiment of the present invention; and

[0030] FIG. 12 is a flowchart for explaining the flow of processing of the ultrasound diagnostic apparatus according to the embodiment of the present invention.

#### DETAILED DESCRIPTION OF THE PREFERRED EMBODIMENTS

[0031] Hereinafter, embodiments of the present invention will be described with reference to the drawings.

[0032] FIG. 1 is a configuration diagram of an ultrasound diagnostic apparatus 1 according to an embodiment of the present invention. The ultrasound diagnostic apparatus 1 of the present embodiment includes an ultrasound endoscope 20, a control device 40, an input device 50 which is connected to the control device 40 and operates the control device 40, and a display device 60 which is also connected to the control device 40 and displays a video signal obtained in the control device 40.

[0033] The ultrasound endoscope 20 is inserted into a body cavity or the like, transmits ultrasound beam toward an observation target region, receives a reflected wave which is reflected by a boarder of an acoustic impedance of the observation target region, and obtains an echo signal. The control device 40 is connected to the ultrasound endoscope 20 with cables 21a and 21b via a connector 40a, controls transmission and reception of the ultrasound endoscope 20, and converts the obtained echo signal into a video signal which can be displayed.

[0034] The ultrasound endoscope 20 has an elongated probe which is inserted into a body cavity or the like, and a transducer group 30, that is, two transducer groups, a CLA (Curved Linear Array) scanning transducer group 31 and an ELR (Electrical Radial) scanning transducer group 32, which transmit and receive ultrasound beam.

[0035] The control device 40 includes a switching section 41 which selects either the transducer group 31 or 32 to switch to it, a transmission and reception processing section 42 which drives the selected transducer group 31 or 32 selected in the switching section 41, and performs wave detection of an echo signal and the like, an image generating section 44 which generates display image data from data obtained in the transmission and reception processing section 42, a switching section 46 which stores an image of either the transducer group 31 or 32, which is selected, in a CLA image memory 47 or an ELR image memory 48, which is the image memory of the transducer group 31 or 32, and a control section 45 which also controls the entire ultrasound diagnostic apparatus.

[0036] The display device 60 has two display areas. A CLA image stored in the CLA image memory 47 is displayed on a display area A60a, and an ELR image stored in the ELR image memory 48 is displayed on a display area B60b.

[0037] Further, the control device 40 includes a synthesis table 43. The transmission and reception section 42 gives a time difference to a drive signal to be transmitted to each transducer element (hereinafter, called a transducer) configuring the transducer group in accordance with the control data stored in the synthesis table 43. As a result, ultrasound having a phase difference corresponding to the time difference of the drive signal is transmitted from each of the transducers. By wavefront synthesis of the transmitted ultrasound having the phase difference, one ultrasound ray along a sound ray in a predetermined direction is synthesized. Each of the transducers which transmit ultrasound receives the echo signal that is the transmitted ultrasound which is reflected and returns, and the echo signals are synthesized to be a signal of one frame in the transmission and reception processing section 42 in accordance with the control data stored in the synthesis table 43 to be frame data for image generation.

[0038] FIG. 2 is a perspective view of a distal end portion of a probe 20a of the ultrasound endoscope 20. The CLA scanning transducer group 31 scans within a surface parallel with a probe shaft in a sector form as shown by a scanning surface 31A. Specifically, respective transducers 31a configuring the CLA scanning transducer group 31 are arranged in the form of a circular arc. Meanwhile, the ELR scanning transducer group 32 scans within a surface perpendicular to the probe shaft in a circular form as shown by a scanning surface 32A. Specifically, respective transducers 32a configuring the ELR scanning transducer group 32 are arranged in a circumferential form. Further, for example, a biopsy needle 22 for extracting a cell sample is caused to perform centesis along the CLA scanning surface 31A.

[0039] FIG. 3A is a front view of the distal end portion of the probe 20a of the present embodiment. FIG. 3B is a side view thereof. As shown in FIGS. 3A and 3B, the CLA scanning surface 31A and the ELR scanning surface 32A are orthogonal to each other. It should be noted that the scanning surface 31A and the scanning surface 32A have the depths corresponding to widths w1 and w2 of the respective transducers.

[0040] FIG. 4A shows a sectional view showing the sound rays of the ELR scanning transducer group 32 according to the present embodiment. FIG. 4B shows a sectional view showing the sound rays of the CLA scanning transducer group 31. In the ELR scanning transducer group 32,  $k_{ELR}$  of the transducers 32a are arranged in a circumferential form, the  $M^{th}$  transducer is set as 32a(M), and a sound ray which is transmitted with the transducer 32a(M) as a center is shown by 32L(M). Similarly, in the CLA scanning transducer group 31,  $k_{CLA}$  of the transducers 31a are arranged in an arc form, the  $N^{th}$  transducer is set as 31a(N), and a sound ray which is transmitted with the transducer 31a(N) as a center is shown by 31L(N).

[0041] In the present embodiment, a radius of curvature r1 of the CLA scanning transducer group 31 and a radius of curvature r2 of the ELR scanning transducer group 32 are the same.

[0042] Therefore, in the CLA scanning transducer group 31 and the ELR scanning transducer group 32, the relative transmission direction of the ultrasound of each of the transducers is the same. Specifically, the relationship of the ultrasound transmission direction of a certain transducer and the ultrasound transmission direction of a transducer adjacent to that transducer is constant.

[0043] Further, in the present embodiment, an arrangement pitch  $\theta p1$  of each of the transducers  $31a$  of the CLA scanning transducer group  $31$  and an arrangement pitch  $\theta p2$  of each of the transducers  $32a$  of the ELR scanning transducer group  $32$  are the same.

[0044] FIG. 5A is a sectional view showing sound ray synthesis of the ELR scanning transducer group  $32$  according to the present embodiment. FIG. 5B is a sectional view showing sound ray synthesis of the CLA scanning transducer group  $31$ . Here, transmission and reception of ultrasound of the transducers is performed while moving in sequence in the directions of R shown in FIGS. 5A and 5B.

[0045] Of a plurality of arranged transducers, high voltage pulses having adjusted delay amounts respectively are applied to some of a plurality of adjacent transducers, ultrasounds of burst waves having adjusted phases are transmitted from the plurality of transducers due to shift of timing of application of high voltage pulses, and by overlapping of the ultrasounds differing in phase, one sound ray is formed. Like this, for formation of a sound ray, a number of transducers are not used individually, but are jointly used in sequence.

[0046] For example, on an occasion of transmission of a  $J^{th}$  transducer, control of causing an adjacent  $(J-1)^{th}$  transducer to perform weak transmission little earlier than the  $J^{th}$  transducer, and causing a  $(J+1)^{th}$  transducer to perform weak transmission a little later than the  $J^{th}$  transducer is conducted. Data for the control is data for sound ray synthesis, and is stored in the sound ray synthesis table.

[0047] In FIG. 5A, a sound ray  $32L(M-1)$  from a transducer  $32a(M-1)$  and a sound ray  $32L(M+1)$  from a transducer  $32a(M+1)$  are synthesized with a sound ray from a transducer  $32a(M)$ , and one sound ray  $32L(M)$  with a focus point of Q is formed. Similarly, in FIG. 5B, a sound ray  $31L(M-1)$  from a transducer  $31a(M-1)$ , and a sound ray  $31L(M+1)$  from a transducer  $31a(M+1)$  are synthesized with a sound ray from a transducer  $31a(M)$ , and one sound ray  $31L(M)$  with a focus point of Q is formed.

[0048] Then, the ultrasound transmitted into a subject (not illustrated) travels inside the examined body while being reflected at each point inside the subject, and the ultrasound reflected at each point inside the subject is received by some of the plurality of adjacent transducers which are arranged and is converted into a reception signal. The reception signals are relatively delayed by the adjusted delay amounts and added to each other, whereby a frame signal expressing a reception sound ray extending inside the subject along the sound ray is formed. Specifically, in FIGS. 5A and 5B, on the occasion of reception of reflected waves of ultrasounds, the reception signals received by three adjacent transducers are synthesized, and one frame signal is obtained.

[0049] Then, by scanning the transducers which perform transmission and reception in sequence while moving in the R direction, the ultrasound image along the scanning surface can be obtained.

[0050] FIG. 6 shows a display example of the ultrasound image displayed on the display device  $60$  of the present embodiment. In FIG. 6, on the display screen  $60$ , an ultrasound image  $60a$  which the ELR scanning transducer group  $32$  scans, and an ultrasound image  $60b$  which the CLA scanning transducer group  $31$  scans are simultaneously displayed. Therefore, an operator can perform diagnosis based on both the images. Further, the display screen  $60$  may have an area  $60c$  on which the diagnosis conditions or the like of the diagnostic apparatus are displayed.

[0051] FIGS. 7 and 8 are flowcharts showing a scanning procedure of each of the transducers configuring the transducer groups of the present embodiment. FIGS. 7 and 8 show examples of the ultrasound diagnostic apparatus having the CLA scanning transducer group  $31$  configured by  $k_{CLA}$  of the transducers  $31a$ , and the ELR scanning transducer group  $32$  configured by  $k_{ELR}$  of the transducers  $32a$ .

[0052] In the scanning procedure shown in FIG. 7, after scanning and display of the entire CLA scanning surface by all  $k_{CLA}$  of the CLA scanning transducers  $31a$  are completed, scanning and display of the entire ELR scanning surface by all  $k_{ELR}$  of the ELR scanning transducers  $32a$  are performed. Then, scanning and display of the entire CLA scanning surface, and scanning and display of the entire ELR scanning surface are repeated.

[0053] Specifically, when scanning is started, a set value N for selecting the transducers to perform scanning first from the CLA surface scanning transducers  $31a$  is initialized (S1). Then, the transmitting and receiving operation of the three adjacent transducers  $31a(N-1)$ ,  $31a(N)$  and  $31a(N+1)$  is performed, and an image of one frame is displayed on the display device (S2). For the control on the occasion of the transmitting and receiving operation, the control data stored in the sound ray synthesis table  $43$  is used.

[0054] Next, in order to obtain the next frame image by using the same CLA scanning transducer group  $31$ , one is added to the set value N (S4). Then, scanning by the next CLA surface scanning transducer  $31a$  is performed. At a point of time when the processing up to a transducer  $31a(k_{CAL}-1)$  at an end of the transducer group  $31$  is completed (S3), specifically, at a point of time when scanning of the entire CLA scanning surface is completed, scanning of the ELR scanning surface is started.

[0055] In scanning of the ELR scanning surface, a set value M for selecting transducers to perform scanning first from the ELR surface transducers  $32a$  is also initialized (S5). Then, the transmitting and receiving operation of the three adjacent transducers  $32a(M-1)$ ,  $32a(M)$  and  $32a(M+1)$  is performed, and an image of one frame is displayed on the display device (S6). For control on the occasion of the transmitting and receiving operation, the control data stored in the same sound ray synthesis table  $43$  as at the time of scanning of the CLA scanning surface is also used.

[0056] Next, in order to obtain the next frame image by using the same ELR scanning transducer group  $32$ , one is added to the set value M (S8). Then, scanning by the next ELR surface scanning transducer  $32a$  is performed. If there is no instruction to end from an operator at a point of time when processing through an ELR surface scanning transducer  $32a(k_{ELR})$  at an end of the transducer group  $32$  is completed (S7), that is, at a point of time when scanning of the entire ELR scanning surface is completed (S9), scanning of the CLA scanning surface is started again. Then, the operation from S1 is repeatedly performed.

[0057] On the other hand, in a scanning procedure of the transducer groups shown in FIG. 8, after scanning and display of a sound ray  $31L(N)$  by using the three transducers  $31a(N-1)$ ,  $31a(N)$  and  $31a(N+1)$  out of  $k_{CLA}$  of the CLA scanning transducers  $31a$ , scanning and display of a sound ray  $32L(M)$  are performed by using the three transducers  $32a(M-1)$ ,  $32a(M)$  and  $32a(M+1)$  out of  $k_{ELR}$  of the ELR scanning transducers  $32a$ . Then, scanning and display of a sound ray  $31L(N+1)$  and scanning and display of a sound ray  $32L(M+1)$  are further performed in sequence.

**[0058]** Specifically, when scanning is started, the set values N and M for selecting transducers to perform scanning first are initialized (S11). Then, transmitting and receiving operation of the three adjacent transducers  $31a(N-1)$ ,  $31a(N)$  and  $31a(N+1)$  of the CLA scanning transducer group **31** is performed, and an image of one frame is displayed on the display device (S12). For control on the occasion of transmitting and receiving operation, the control data stored in the sound ray synthesis table **43** is used. If the scanned and displayed transducer  $31a$  is not the transducer  $31a(k_{CAL}-1)$  at the end of the CLA transducer group **31** (S13), one is added to the set value N (S15). If the scanned and displayed transducer  $31a$  is the transducer  $31a(k_{CAL}-1)$  (S13), N is initialized (S14) in preparation for the next scanning and display.

**[0059]** Next, transmitting and receiving operation of the three adjacent transducers  $32a(M-1)$ ,  $32a(M)$  and  $32a(M+1)$  of the ELR scanning transducer group **32** is performed, and an image of one frame is displayed on the display device (S16). For control on the occasion of the transmitting and receiving operation, the control data stored in the same sound ray synthesis table **43** as at the time of scanning of the CLA scanning surface is used. If the scanned and displayed transducer  $32a$  is not the transducer  $32a(k_{ELR})$  at the end of the ELR transducer group **32** (S17), one is added to the set value M (S19). If the scanned and displayed transducer  $32a$  is the transducer  $32a(k_{ELR})$  (S17), M is initialized (S18) in preparation for the next scanning and display. Then, until the instruction to end is given from the operator (S20), the operation from S12 is repeatedly performed.

**[0060]** In the scanning procedure shown in the flowchart of FIG. 8, new frame display is performed for the display device **60** for each one frame signal by the CLA scanning transducer group **31** or the ELR scanning transducer group **32**. Specifically, the ultrasound diagnostic apparatus using the scanning procedure shown in the flowchart of FIG. 8 switches the transducer group to perform scanning each time one sound ray is scanned by scanning of a plurality of transducer groups. Therefore, as compared with the ultrasound diagnostic apparatus using the scanning procedure shown in FIG. 7, a time shift between the CLA scanning surface display **60b** and the ELR scanning surface display **60a** is eliminated, and an image which is more real-time can be displayed for the operator.

**[0061]** The transducer  $31a(1)$  at the end of the CLA scanning transducer group **31** is only used for synthesis of the sound ray  $31L(2)$ , and does not transmit a sound ray  $31L(1)$ . Similarly, the transducer  $31a(k_{CLA})$  at the other end of the CLA scanning transducer group **31** is only used for synthesis of the sound ray  $31L(k_{CLA}-1)$ , and does not transmit a sound ray  $31L(k_{CLA})$ . On the other hand, a sound ray  $32L(1)$  of the ELR scanning transducer group **32** is synthesized from three transducers that are transducers  $32a(k_{ELR})$ ,  $32a(1)$  and  $32a(2)$ , and a sound ray  $32L(k_{ELR})$  is similarly synthesized from three transducers that are transducers  $32a(k_{ELR}-1)$ ,  $32a(k_{ELR})$  and  $32a(1)$ .

**[0062]** Therefore, in the flowcharts of FIGS. 7 and 8, the initial value of the set value N on the occasion of CLA scanning is two, and the transducer **31** which transmits the sound ray at the end of the CLA scanning transducer group **31** is the transducer  $31a(k_{CAL}-1)$ , whereas the initial value of the set value M on the occasion of ELR scanning is one, and the last transducer **32** of the ELR scanning transducer group **32** is the transducer  $32a(k_{ELR})$ .

**[0063]** In order to obtain one sound ray and one frame data by cooperative operation of a plurality of transducers as described above, the control data such as drive control data for transmission and reception and parameters for processing the received data have to be obtained in advance and stored in the sound ray synthesis table. In order to share the sound ray synthesis table by a plurality of transducer groups, the sound ray directions of the respective transducers, that is, relative transmitting directions of ultrasounds need to correspond to each other between the respective transducer groups. In other words, the radiuses of curvature of the transducer groups which share the sound ray synthesis table have to be the same. If the transducer groups are not the transducer groups of such a special combination, the common sound ray synthesis table cannot be used, and common use by switching of the transducer groups by the switching section cannot be performed.

**[0064]** Further, the disposition spaces of the individual transducers of the transducer groups which share the table, that is, the pitch  $\theta p1$  and the pitch  $\theta p2$  preferably correspond to each other.

**[0065]** Further, in the above described embodiment, the example of synthesizing one sound ray from the three adjacent transducers is described, but one sound ray may be synthesized from the number of transducers exceeding three. Further, by conducting control using a pseudo sound ray, not only sound rays can be transmitted from the transducers at both ends of the CLA transducer group, but also the common sound ray synthesis table can be used even by the transducer groups differing in a pitch  $\theta p$ .

**[0066]** In the above described embodiment, the example in which one radial transducer group and one convex transducer group, that is, two transducer groups are used is described, but a plurality of transducer groups that are three or more can be used by being switched. FIGS. 9A to 9C, 10A to 10C and 11A to 11C are views showing scanning surfaces in the ultrasound diagnostic apparatuses each having a plurality of transducer groups which scan within the surfaces orthogonal to each other. FIGS. 9A, 10A and 11A are front views each observed in a direction perpendicular to a scope longitudinal direction. FIGS. 9B, 10B and 11B are top views each observed from a top surface with respect to the scope longitudinal direction. FIGS. 9C, 10C and 11C are side views each observed from a side surface with respect to the scope longitudinal direction.

**[0067]** FIGS. 9A to 9C show an example of scanning two surfaces A1 and A2 by using one of each of the same radial transducer group and convex transducer group as the above described embodiment, that is, two transducer groups. On the other hand, FIGS. 10A to 10C show an example of scanning three surfaces A1, A2 and A3 by using one radial transducer group and two convex transducer groups, that is, three transducer groups. FIGS. 11A to 11C show an example of scanning five surfaces A1, A2, A3, A4 and A5 by using one radial transducer group and four convex transducer groups, that is, five transducer groups. Even in each of the embodiments in which the number of transducer groups is three or more, the basic configurations are the same as those of the embodiment in which the number of transducer groups is two.

**[0068]** In the ultrasound diagnostic apparatus using a plurality of electronic scanning type transducer groups, an ultrasound diagnostic apparatus in which by using the probe having the transducer group configured by a plurality of transducers arranged in a circumferential or arc form having a same radius of curvature, the sound ray synthesis table is

shared, and one transmission and reception section and one image generating section and the like are usable by being switched is described.

**[0069]** However, by including a plurality of sets of transmission and reception sections, image generating sections and the like, the ultrasound diagnostic apparatus according to the embodiment of the present invention has the advantage of being continuously usable by switching a set of transmission and reception section, image generating section and the like to the other set of the transmission and reception section, image generating section and the like which are not out of order when the one set of the transmission and reception section, image generating section and the like is out of order. Especially when three or more transducer groups are used, the processing speed may become low when one set of a transmission and reception section, an image generating section and the like is shared, and a plurality of sets of transmission and reception sections, image generating sections and the like are preferably included.

**[0070]** Next, an ultrasound diagnostic apparatus according to another embodiment of the present invention will be described. In the ultrasound diagnostic apparatus according to the present embodiment, scanning of a plurality of transducer groups is in accordance with a sequence set in advance, and the transducer group to perform scanning is switched. Specifically, in the ultrasound diagnostic apparatus already described, for example, in the scanning procedure shown in the flowchart of scanning of the respective transducers configuring the transducer groups in FIG. 7, at the point of time when scanning of the entire CLA scanning surface is completed, scanning of the ELR scanning surface is started, and at the point of time when the scanning of the entire ELR scanning surface is completed, scanning of the CLA scanning surface is started. Specifically, at the point of time when scanning of the entire scanning surface of each of the transducer groups is completed, the transducer group to perform scanning is switched. Further, in the ultrasound diagnostic apparatus already described, in the scanning procedure shown in the flowchart of scanning of the respective transducers configuring the transducer groups of FIG. 8, for example, the transducer group to perform scanning is switched at every one frame signal by the CLA scanning transducer group 31 or the ELR scanning transducer group 32.

**[0071]** On the other hand, in the ultrasound diagnostic apparatus according to the different embodiment of the present invention, the transducer group to perform scanning is switched in accordance with the sequence which is set in advance. Further, the scanning image displayed on the display device 60 may be only the image of the transducer group which performs scanning.

**[0072]** Hereinafter, the flow of the process of the ultrasound diagnostic apparatus according to the present embodiment will be described by using FIG. 12. FIG. 12 is a flowchart for explaining the flow of the process of the ultrasound diagnostic apparatus according to the present embodiment.

**[0073]** In the ultrasound diagnostic apparatus of the present embodiment, when the ultrasound endoscope 20 is connected to the control device 40, the control device 40 determines whether the connected ultrasound endoscope 20 is an endoscope probe having a plurality of transducer groups, for example, a biplane probe (step S31). When the connected probe is an ordinary probe, that is, a probe having only one

transducer group, it is determined as No in step S31, and the process from step 32 is performed in sequence.

**[0074]** On the other hand, when it is determined as Yes in step S31, detailed classification of the connected probe is further determined (step S38). Then, a mode capable of scanning with the connected probe, for example, a radial mode, a convex mode, a linear mode or the like is determined (step S39).

**[0075]** Subsequently, in step S40, a selection screen for setting a scanning mode, that is, setting the transducer group to perform scanning in advance from a plurality of transducer groups is displayed on a display device 70 or the like. In the selection screen, the transducer group to perform scanning, the scanning sequence, the scanning switching timing (time) and the like can be set. By a scanning mode setting instruction of the operator from the selection screen, the control circuit 40 switches the transducer group for scanning in accordance with the sequence or the like set in advance.

**[0076]** In step S40, when only one transducer group is selected from a plurality of transducer groups, it is determined as Yes in step S41, and the process from step 42 is performed in sequence.

**[0077]** On the other hand, in step S41, when it is determined as No, combination for switching the transducer group to perform scanning is set in accordance with the sequence or the like set in advance in step S40 (step S47), and transmission and reception control of one transducer group to perform scanning first is set by the control device 40 (step S48). Subsequently, transmission and reception data acquisition and image generation of the one transducer group which performs scanning first are performed (step S49). Next, the control device 40 performs transmission and reception control setting of one transducer group which is set to perform scanning next (step S50) and performs transmission and reception data acquisition and image generation (step S51), and displays the image (step S45).

**[0078]** In each scanning, scanning is continuously performed until the instruction to stop scanning or the like is given from the operator.

**[0079]** In the ultrasound diagnostic apparatus of the present embodiment, scanning switching of a plurality of transducer groups can be set in advance as the operator desires. Therefore, the ultrasound diagnostic apparatus of the present embodiment is further excellent in operability in addition to the effect of the aforementioned ultrasound diagnostic apparatus according to the present invention has.

**[0080]** Having described the preferred embodiments of the invention referring to the accompanying drawings, it should be understood that the present invention is not limited to those precise embodiments and various changes and modifications thereof could be made by one skilled in the art without departing from the spirit or scope of the invention as defined in the appended claims.

What is claimed is:

1. An ultrasound diagnostic apparatus, comprising:
  - a plurality of transducer groups which are provided at a distal end portion of a probe and configured by a plurality of transducers arranged in a circumferential form or an arc form having a same radius of curvature; and
  - a common sound ray synthesis table storing control data of the respective transducer groups.

- 2. The ultrasound diagnostic apparatus according to claim 1, further comprising a display section having a display screen capable of simultaneously displaying a plurality of ultrasound images,
  - wherein a plurality of ultrasound images scanned by the plurality of transducer groups are simultaneously displayed on the display section.
- 3. The ultrasound diagnostic apparatus according to claim 1,
  - wherein arrangement pitches of the transducers configuring the respective transducer groups are the same.
- 4. The ultrasound diagnostic apparatus according to claim 1,
  - wherein scanning of the plurality of transducer groups is in accordance with a sequence which is set in advance, and the transducer group to perform scanning is switched.
- 5. The ultrasound diagnostic apparatus according to claim 1,
  - wherein the transducer group to perform scanning is switched each time scanning of the plurality of transducer groups scans one sound ray.
- 6. The ultrasound diagnostic apparatus according to claim 1,
  - wherein the plurality of transducer groups scan within surfaces orthogonal to each other.
- 7. The ultrasound diagnostic apparatus according to claim 1,
  - wherein three or five transducer groups are used.
- 8. An ultrasound diagnostic apparatus, comprising:
  - an elongated probe;
  - an ELR scanning transducer group and a CLA scanning transducer group which are provided at a distal end portion of the probe, are configured by ELR scanning transducers arranged in a circumferential form and CLA

- scanning transducers arranged in an arc form, which have same radiuses of curvature, and scan within surfaces orthogonal to each other; and
- a common sound ray synthesis table storing control data of the ELR scanning transducer group and the CLA scanning transducer group.
- 9. The ultrasound diagnostic apparatus according to claim 8, further comprising a display section having a display screen capable of simultaneously displaying two ultrasound images,
  - wherein two ultrasound images scanned by the ELR scanning transducer group and the CLA scanning transducer group are simultaneously displayed on the display section.
- 10. The ultrasound diagnostic apparatus according to claim 8,
  - wherein an arrangement pitch of the ELR scanning transducers configuring the ELR scanning transducer group and an arrangement pitch of the CLA scanning transducers configuring the CLA scanning transducer group are the same.
- 11. The ultrasound diagnostic apparatus according to claim 8,
  - wherein scanning of the ELR scanning transducer group and scanning of the CLA scanning transducer group are in accordance with a sequence set in advance, and the transducer group to perform scanning is switched.
- 12. The ultrasound diagnostic apparatus according to claim 8,
  - wherein the transfer group to perform scanning is switched each time scanning of the ELR scanning transducer group and scanning of the CLA scanning transducer group scan one sound ray.

\* \* \* \* \*

专利名称(译)	超声诊断仪		
公开(公告)号	<a href="#">US20090082674A1</a>	公开(公告)日	2009-03-26
申请号	US12/234123	申请日	2008-09-19
[标]申请(专利权)人(译)	奥林巴斯医疗株式会社		
申请(专利权)人(译)	奥林巴斯医疗系统股份有限公司.		
当前申请(专利权)人(译)	奥林巴斯医疗系统股份有限公司.		
[标]发明人	HIBI YASUSHI		
发明人	HIBI, YASUSHI		
IPC分类号	A61B8/00		
CPC分类号	A61B8/0833 A61B8/0841 A61B8/12 A61B8/145 A61B8/4488 A61B8/445 A61B8/463 G01S7/52074 G01S15/892 G01S15/8929 A61B8/461		
优先权	2007245785 2007-09-21 JP		
外部链接	<a href="#">Espacenet</a> <a href="#">USPTO</a>		

摘要(译)

超声诊断设备是具有多个换能器组的超声诊断设备，其具有简单的设备配置，其具有设置在探头的远端部分处的多个换能器组，并且由布置在圆周中的多个换能器构成。具有相同曲率半径的形式或弧形形式，以及存储各个换能器组的控制数据的公共声线合成表。

