



US008147409B2

(12) **United States Patent**
Shifrin

(10) **Patent No.:** **US 8,147,409 B2**
(45) **Date of Patent:** **Apr. 3, 2012**

(54) **METHOD AND APPARATUS FOR
TRANSDUCER EXCITATION IN MEDICAL
ULTRASOUND IMAGING**

(75) Inventor: **Lazar A. Shifrin**, San Jose, CA (US)

(73) Assignee: **SuperTex, Inc.**, Sunnyvale, CA (US)

(*) Notice: Subject to any disclaimer, the term of this patent is extended or adjusted under 35 U.S.C. 154(b) by 737 days.

6,104,673	A	8/2000	Cole et al.
6,135,963	A	10/2000	Haider
6,241,676	B1	6/2001	Savord
6,312,379	B1	11/2001	Bradley et al.
6,432,055	B1	8/2002	Carp et al.
6,469,957	B1	10/2002	Savord et al.
6,537,216	B1	3/2003	Shifrin
6,595,921	B1 *	7/2003	Urbano et al. 600/437
7,022,074	B2 *	4/2006	Kristoffersen et al. 600/437
2004/0254459	A1	12/2004	Kristoffersen et al.
2005/0033168	A1 *	2/2005	Shifrin 600/437
2008/0242987	A1	10/2008	Shifrin

OTHER PUBLICATIONS

PCT Search Report and Written Opinion mailed on Aug. 1, 2008 in connection with the related PCT Patent Application No. US2008/03872.

EP Supplementary European Search Report dated Apr. 8, 2011, in connection with the related EP Patent Application No. 08 72 7132. *Fractional/Integer-N PLL Basics*, Texas Instruments, Technical Brief Aug. 1999.

* cited by examiner

Primary Examiner — Brian Casler
Assistant Examiner — Peter Luong

(21) Appl. No.: **12/053,235**

(22) Filed: **Mar. 21, 2008**

(65) **Prior Publication Data**

US 2008/0242987 A1 Oct. 2, 2008

Related U.S. Application Data

(60) Provisional application No. 60/920,606, filed on Mar. 29, 2007.

(51) **Int. Cl.**
A61B 8/00 (2006.01)

(52) **U.S. Cl.** **600/437; 600/407; 600/443**

(58) **Field of Classification Search** **600/407, 600/437, 443**

See application file for complete search history.

(56) **References Cited**

U.S. PATENT DOCUMENTS

4,794,933	A *	1/1989	Yamazaki	600/455
5,549,111	A	8/1996	Wright et al.		
5,833,614	A	11/1998	Dodd et al.		
5,970,025	A	10/1999	Cole et al.		

(57) **ABSTRACT**

A method of transducer excitation in medical ultrasound imaging. Based on a stepped approximation of Gaussian modulated cosines, the transmit waveform provides bandlimited spectrum and low level of second order harmonics while retaining the duration of the transmitting within two carrier cycles. The waveform is constructed as a linear composition of four unipolar, rectangle pulses of unity amplitude. Furthermore, the described embodiment supports digitally controlled transmit apodization and focusing.

20 Claims, 6 Drawing Sheets

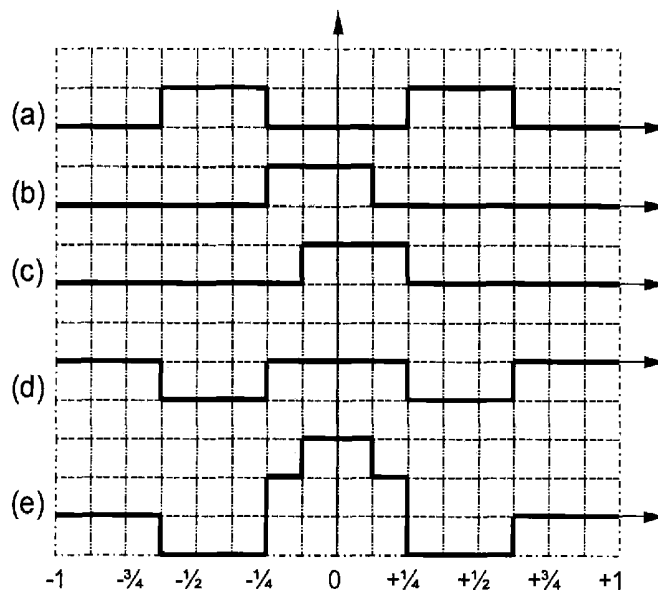

1st (a), 2nd (b), and 3rd (c) Base Waveforms & Their Combining (d, e)

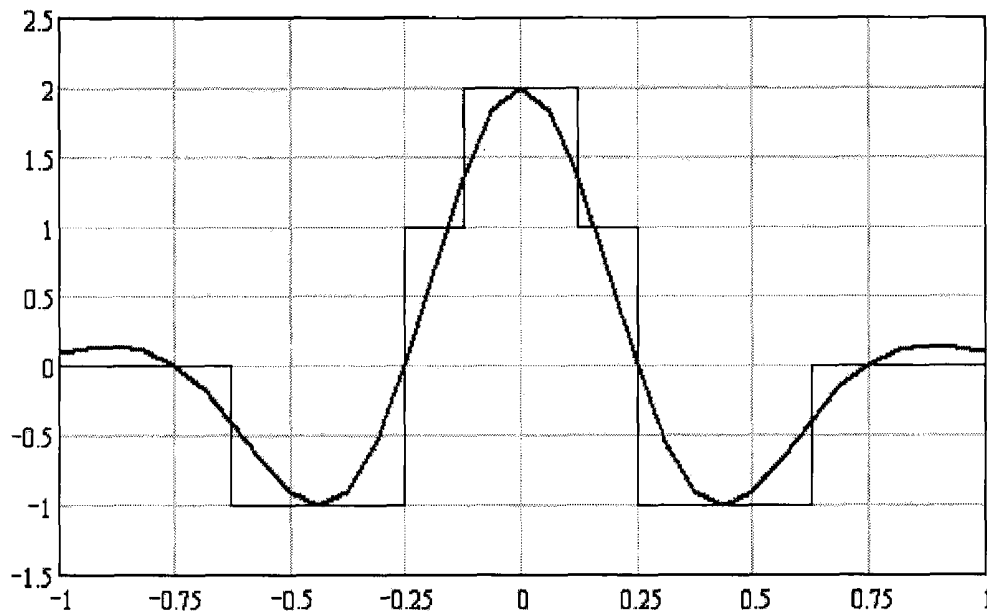

FIG. 1

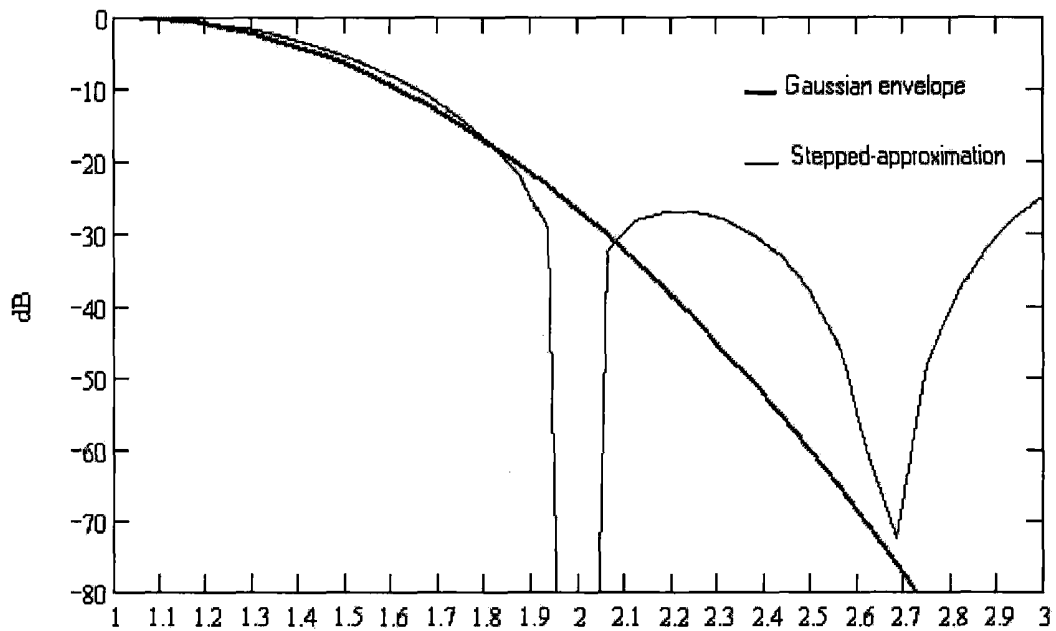

FIG. 2

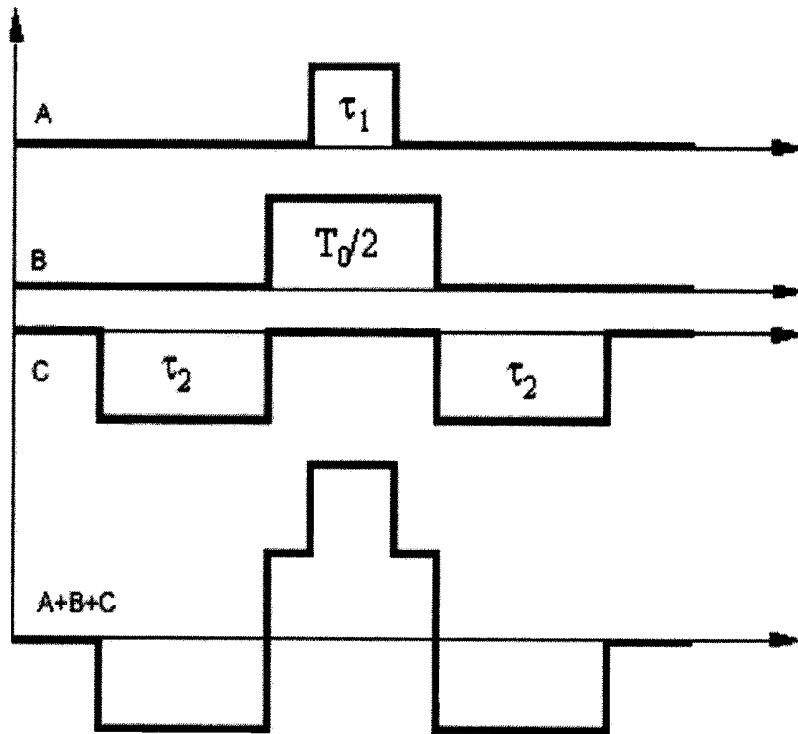

FIG. 3a

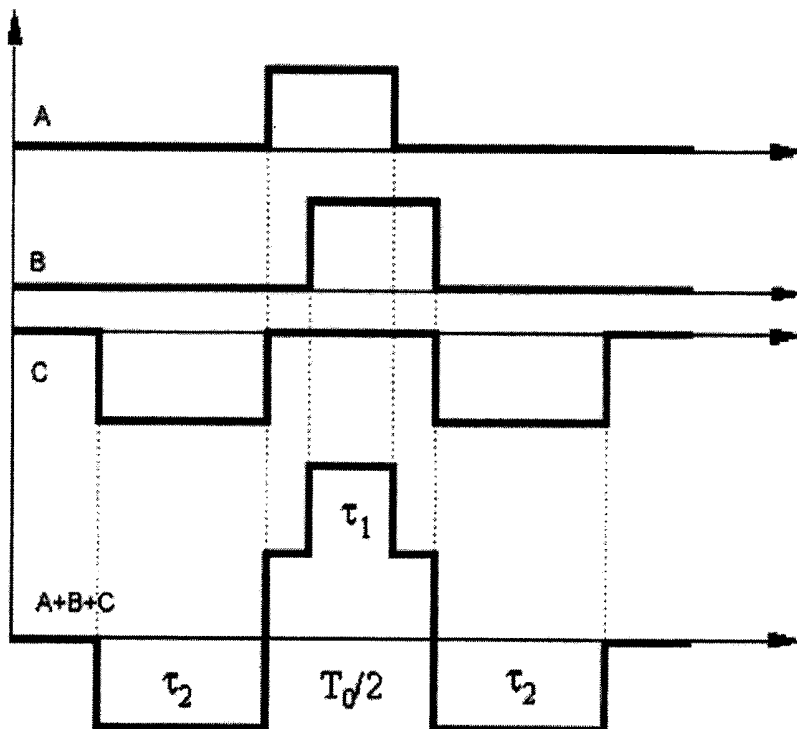

FIG. 3b

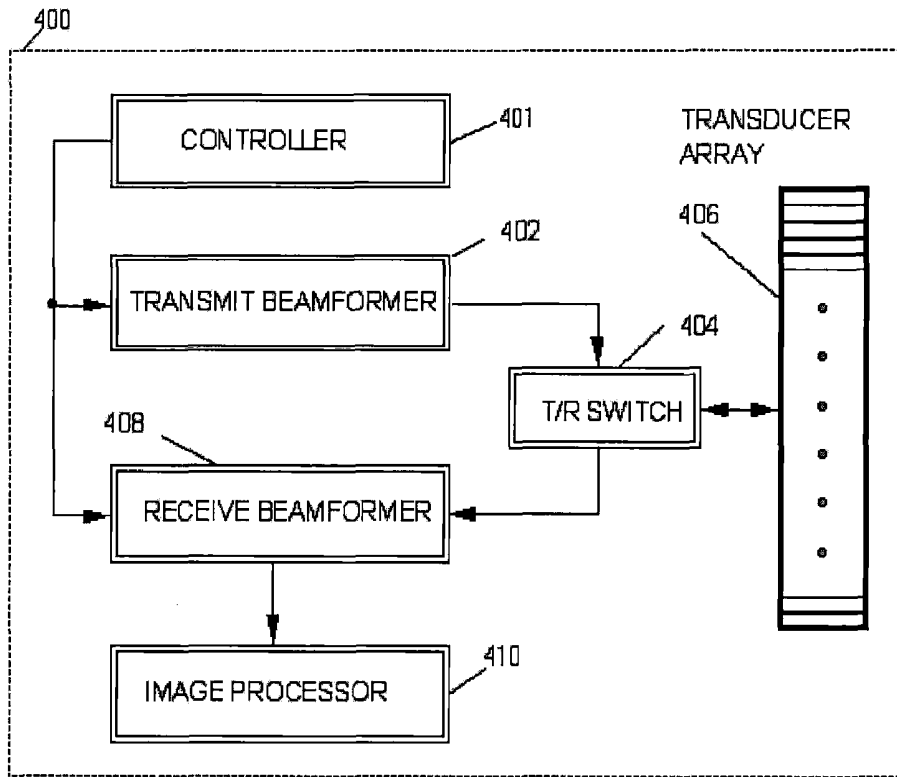
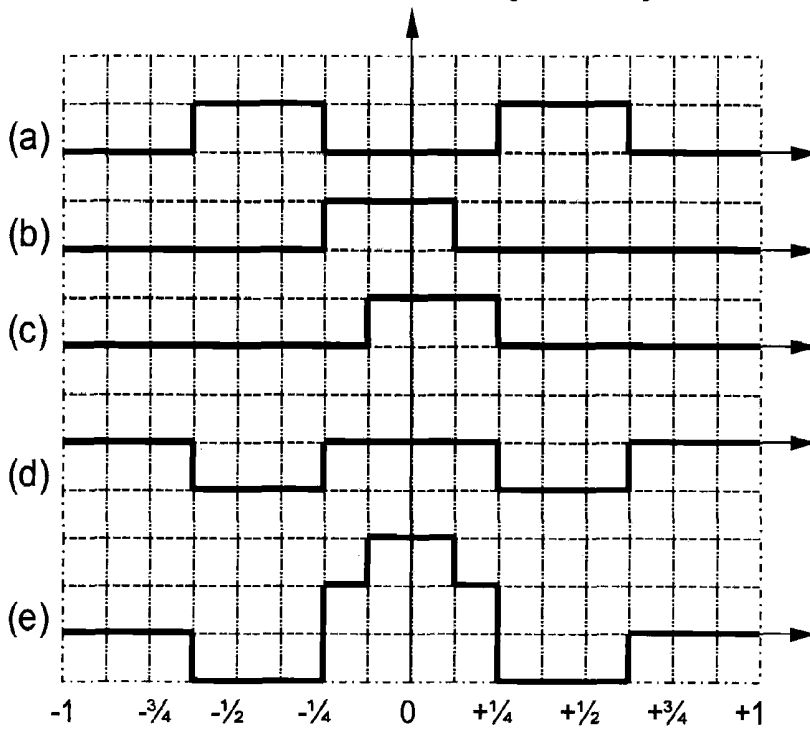

FIG. 4 (Prior Art)



1st (a), 2nd (b), and 3rd (c) Base Waveforms & Their Combining (d, e)

FIG. 5

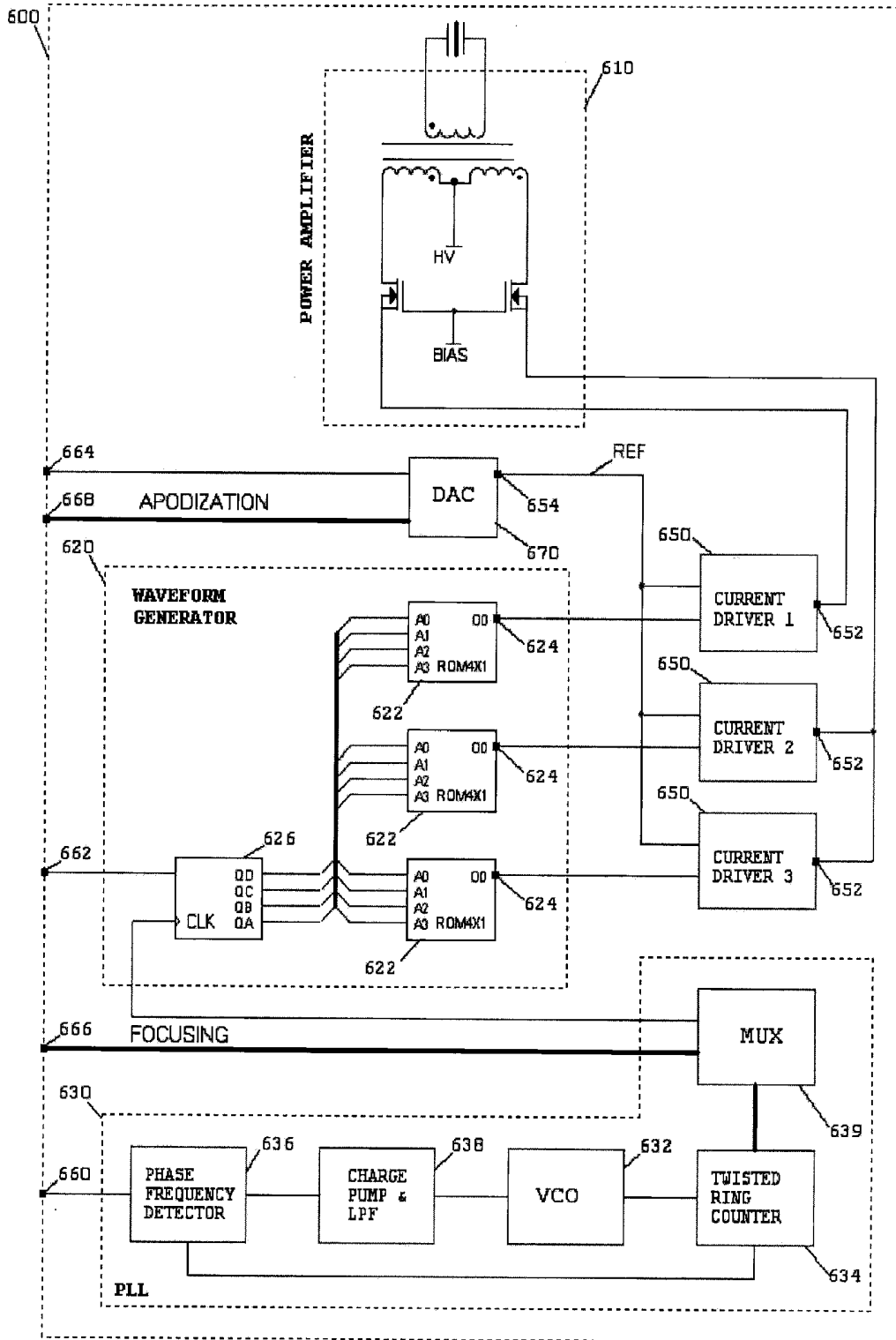

FIG. 6

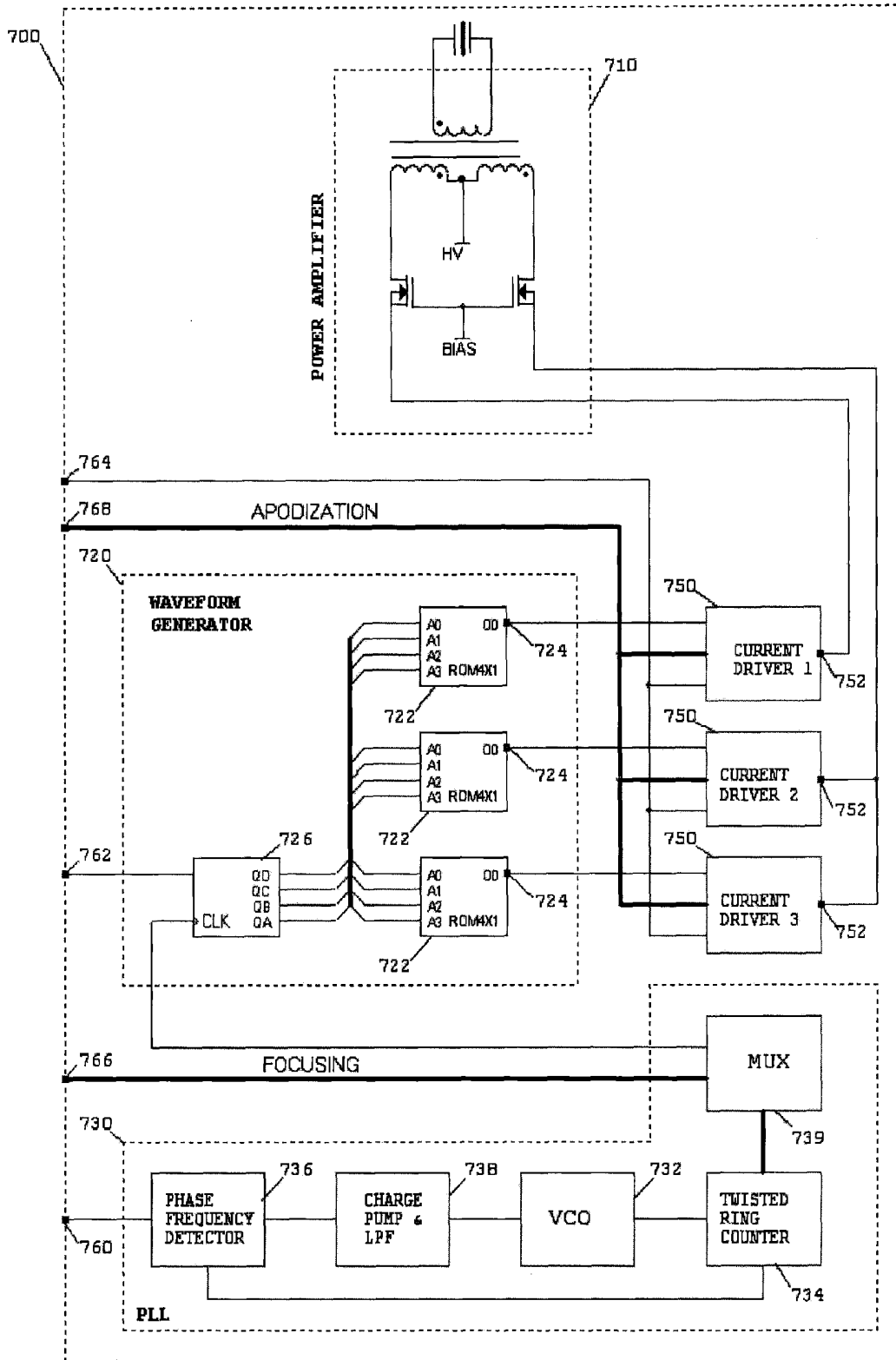

FIG. 7

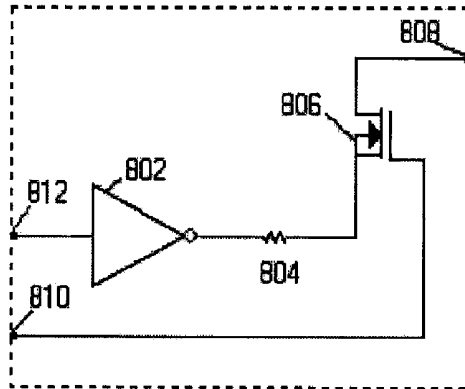

FIG. 8

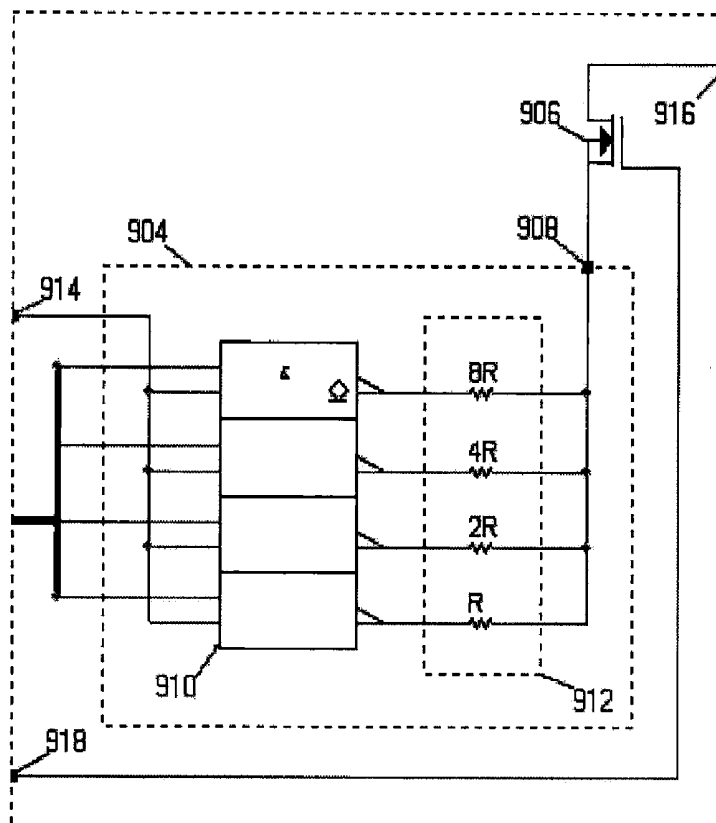

FIG. 9

METHOD AND APPARATUS FOR TRANSDUCER EXCITATION IN MEDICAL ULTRASOUND IMAGING

RELATED APPLICATIONS

This patent application claims the benefit of U.S. Provisional Patent Application Ser. No. 60/920,606, filed Mar. 29, 2007 in the name of Lazar A. Shifrin, and entitled "Method and Means for Transducer Excitation in Medical Ultrasound Imaging", which is incorporated herein by reference in its entirety.

TECHNICAL FIELD

This invention relates to medical ultrasound imaging systems, and, in particular, phased array scanners operating in different scan formats and imaging modes, and characteristics of the ultrasonic transmit pulses and transmit pulse generators for such scanners.

BACKGROUND

Generally, characteristics of the transmitted pulse are linked with a particular imaging mode. For example, the duration of the pulse is adjusted depending on whether the scanner operates in B-Mode, Pulsed Wave (PW) Doppler, or Color Flow Imaging. Likewise, the center frequency of the pulse is set according to the frequency response of a transducer.

To improve the propagation characteristics of the sound wave, the interrogating pulse of many medical ultrasonic imaging systems is constituted as a carrier wave modulated by a gradually rising and gradually falling amplitude envelope. In some cases, the envelope of the pulse is Gaussian in shape. Its advantage is that an initially Gaussian pulse retains its Gaussian shape during propagation through an attenuating media such as tissue.

One more reason for shaping transmit pulses has come in conjunction with the harmonic imaging where it is particularly valuable to reduce the level of even harmonics.

Summarizing, both fundamental and sub-harmonic mode ultrasound imaging are all improved by controlling the bandwidth of the frequency spectrum of the transmitted ultrasonic pulse. This bandwidth is preferably limited to frequencies around the fundamental, and is preferably sharply reduced at specified harmonics and sub-harmonics of the fundamental.

Referring to the transmit techniques, there are two main classes of ultrasound transmitters: pulsers and so-called arbitrary waveform generators (AWG).

Arbitrary waveform generators have been advanced solution for high-end ultrasound systems (by way of example, see U.S. Pat. Nos. 5,549,111, 5,970,025, 6,104,673, and 6,469,957). AWGs can provide instantaneous change in transmit energy between transmit pulses, apodization profiles with greater resolution, and acoustic beams with lower harmonic content. Transmit signals produced by an AWG are typically Gaussian or Hamming modulated cosines individually formed for each transducer element. In operation, AWGs use stored digital representations of shaped waveforms, comprising a digital-to-analog converter and a power amplifier (see U.S. Pat. No. 6,537,216) to produce an analog drive signal for the transducer. However, the current implementation of arbitrary waveform transmitters is limited because of its high manufacturing cost, power dissipation and space constraints.

A typical excitation signal produced by a pulser looks like a gated square wave of a desired carrier frequency. The wave-

form shape or envelope is essentially fixed, and, therefore, not optimal. The only adjustable parameter of a basic pulser is the length of the gate in terms of an integer number of carrier cycles. Advanced pulsers use the pulsewidth modulation (PWM) techniques and operate as described below.

To generate the PWM transmit waveform, the modulating signal is compared with a high frequency sawtooth or triangle waveform that acts as a carrier. The resulting binary signal of the comparator feeds a suitable set of power switches connected to the power supplies. Having low power dissipation, PWM (or class-D) pulsers can be effectively integrated. For the same reason, the PWM pulsers are more preferable in terms of heatsinking. These factors and the relatively low cost of such ultrasound transmit circuits are the forces behind the motivation of their widespread use.

By way of example, U.S. Pat. No. 6,135,963 entitled "Imaging System with Transmit Apodization Using Pulse-Width Variation" describes a method and apparatus for transmit apodization by controlling the duty cycle of the pulse.

U.S. Pat. No. 5,833,614 and No. 6,432,055 discuss several types of PWM transmit waveforms that can be used to approximate a carrier wave modulated by a gradually rising and gradually falling amplitude envelope. Such PWM waveforms include various unipolar sequences having two voltage levels (+V, 0) and bipolar sequences having three voltage levels (+1V, 0, and -1V).

Ultrasound equipment with harmonic imaging capabilities transmits a signal at one frequency and receives the echoes at twice that frequency. A substantial obstacle to using second harmonic imaging with PWM is minimizing transmit energy at the second harmonic frequency. One solution is based on selecting the number of cycles of a carrier frequency that are transmitted in a square wave pulse burst. A greater number of carrier cycles in the burst corresponds to a narrower signal bandwidth. However, any increase in the number of carrier cycles results in a lower range resolution of the system.

Pulse inversion harmonic imaging exploits two pulse bursts with the second burst as an inverse replica of the first one. This routine cancels even order distortion products that are capable of masking a valuable harmonic information generated by tissue. However, the alternation halves the image update rate. On the contrary, operating at higher frame rates is particularly important for cardiac imaging.

Yet another approach is to use a bipolar (3-state) uniform square wave pulse train, which has less energy around the second harmonic frequency than does a unipolar uniform square wave pulse train of the same length.

To suppress energy at second order harmonics further, U.S. Pat. No. 5,833,614 teaches the transmit waveform comprising pairs of identical pulses. The width of the pulses within each pair is modulated as a function of the envelope amplitude. These pulses are phase delayed by 90 degrees relative to each other. However, increasing the number of alteration in a waveform results in higher sampling rate and, generally, a more complex transmit beamformer. At the same time, while the second harmonic is substantially suppressed, the intensity of the odd harmonics is noticeable. For instance, referring to U.S. Pat. No. 5,833,614, the third harmonic level is approximately -4 dB.

An alternative 3-state, pulse width modulated, bipolar waveform is disclosed by U.S. Pat. No. 6,432,055. This pulse train is constructed by summing a first component with an inverted, time-shifted version of the first component. As shown in U.S. Pat. No. 6,432,055, by properly selecting the time interval for the time shift of the second component, filtering of the second harmonic can be obtained. At the same

time, the filtered pulse spectrum is broadband including high-order harmonics and sub-harmonics of the fundamental, each of a considerable intensity.

Therefore, there is still a need for improved transmit sequences that are band-limited and suppress energy at selected harmonic frequencies, and for transmit generators that are capable of generating such sequences.

SUMMARY

By way of introduction, the present invention includes a method and an apparatus for ultrasound transmit excitation.

The present invention may provide a transmit waveform that is characterized by essentially bandlimited spectrum and low level of second order harmonics.

The present invention may also provide a new ultrasound transmitter that outperforms the prior art by simplicity, versatility, lower cost, and higher power efficiency, while maintaining programmability for carrier frequency, transmit beamforming and apodization profile.

In a first aspect, the transmit waveform represents a stepped approximation of Gaussian modulated cosines. The transmit waveform is constructed as a linear composition of four unipolar, rectangle pulses of a unity amplitude. By properly selecting the width of the pulses and their timing relationship, the transmit waveform spectrum shape is close to a Gaussian while all even harmonics are filtered out. In amplitude terms, the transmit waveform has four voltage levels, namely, +2V, +1V, 0, -1V. The zero-mean transmit waveform spans over two carrier cycles.

In the second aspect, transmit beam formation is supported by controlling the time at which the excitation is initiated.

In the third aspect, sampling is occurred at a rate 8 times the predetermined carrier frequency.

Further aspect and advantages of the invention are discussed below in conjunction with the described embodiments.

BRIEF DESCRIPTION OF THE DRAWINGS

The invention will be described with respect to particular embodiments thereof referring to the following drawings:

FIG. 1 depicts a preferred transmit waveform (mathematically described as Gaussian modulated cosines) and a stepped approximation of said waveform. In FIG. 1, time is measured in units of fractions of the period, T_0 , of the fundamental (or carrier) frequency F_0 .

FIG. 2 depicts spectrums, which are associated with the waveforms of FIG. 1.

FIG. 3a and FIG. 3b depict two alternative embodiments of constructing of a stepped approximation of the Gaussian modulated cosines of FIG. 1.

FIG. 4 is a block diagram illustrating a conventional ultrasonic imaging system operative to implement the present invention.

FIGS. 5a through 5e illustrate timing diagrams of the operation of the waveform generator.

FIG. 6 is a block diagram of an embodiment of an ultrasound transmitter suitable for implementation with the imaging system of FIG. 4.

FIG. 7 is a block diagram of another embodiment of an ultrasound transmitter suitable for implementation with the imaging system of FIG. 4.

FIG. 8 is a schematic diagram of an embodiment of the current driver of the ultrasound transmitter of FIG. 6.

FIG. 9 is a schematic diagram of an embodiment of the current driver of the ultrasound transmitter of FIG. 7.

DETAILED DESCRIPTION

The following sections will first discuss an improved ultrasonic transmit sequence that represents a stepped approximation of Gaussian modulated cosines and will then discuss different transmitters for generating such signals.

10 Transmit Waveforms

Typically, in order to generate a pulsewidth modulation (PWM) transmit sequence, the envelope of an amplitude-modulated waveform is first sampled at a plurality of points. The number of points sampled depends on the sampling frequency, F_S , and the duration of the envelope, T_E . Preferably, $F_S = M \cdot T_E$, where M is the number of samples. Lowering the value of M results in fewer pulses in the PWM transmit pulse train and, generally, a less complex transmit beamformer. In any case, the width of each pulse is proportional to the amplitude of the envelope at the sampling point. Thus, the duration of the pulses increases gradually to a maximum value and then decreases gradually like the amplitude of the envelope.

To reduce the transmitter complexity and manufacturing cost, the PWM transmit sequence is rather coarsely sampled, such as at a rate of eight or even four samples per carrier cycle. Thus, in order to eliminate possible aliasing effects, the signal to be sampled should be limited in spectral content. Consequently, the original PWM transmit waveform includes at least two carrier cycles.

Implementing a relatively short PWM transmit waveform, an ultrasound system would provide a satisfactory range resolution. However, such a waveform has a high second harmonic content. Thus, with the exception of using a pulse-inversion technique, a traditionally composed PWM transmit sequence is not suitable for harmonic imaging. As previously discussed, various filtering techniques allow suppression of the second harmonic distortion. However, this results in a higher sampling rate, widens the transmit spectrum, and might increase the intensity of the odd harmonics.

In the present invention, synthesis of an improved transmit pulse train involves a stepped approximation of Gaussian modulated cosines as shown in FIG. 1. Then, the step-approximated transmit waveform of FIG. 1 is decomposed into three base pulse sequences as depicted as A, B, C and A+B+C in FIG. 3a. An alternative but equivalent transmit waveform partition is shown in FIG. 3b. The base waveforms A and B in FIGS. 3a and 3b are unipolar in that the polarity of two or more pulses is the same (e.g., positive or negative) regardless of the amplitude. The pulse train C comprises two unipolar unity amplitude rectangle pulses. The polarity of C is inverted with respect to A or B. Both partitions satisfy the following basic requirements:

The coupling between ultrasonic transmitters and transducers may be provided by a transformer, in one embodiment, or a capacitor, in another embodiment, and, thus, no DC component in the transmit waveform is expected. Referring to FIG. 3a, this condition can be achieved if a voltage-time product of positive (A+B) and negative (C) pulse trains are equal. With unity amplitude rectangular pulses, the voltage-time product yields:

$$\tau_1 = 2 \cdot \tau_2 \cdot T_0 / 2 \quad (1)$$

where the time T_0 is the period of the fundamental frequency F_0 , the time τ_1 is the duration of a pulse exhibited in the A pulse train, the time τ_2 is the duration of pulses presented in the C pulse train.

The spectrum, $S_0(f)$, of a unity amplitude rectangular pulse having a duration of τ is given by:

$$S_0(f) = \frac{\sin(\pi \cdot f \cdot \tau)}{\pi \cdot f} \quad (2)$$

where f is the frequency variable.

Thus, the spectrums of the base sequences A, B, and C can be expressed as:

$$S_A(f) = \frac{\sin(\pi \cdot f \cdot \tau_1)}{\pi \cdot f} \quad (3)$$

$$S_B(f) = \frac{\sin(\pi \cdot f \cdot T_0/2)}{\pi \cdot f} \quad (4)$$

$$S_C(f) = \frac{\sin(\pi \cdot f \cdot T_0/2)}{\pi \cdot f} - \frac{\sin[\pi \cdot f \cdot (2 \cdot \tau_2 + T_0/2)]}{\pi \cdot f} \quad (5)$$

Substituting Equation 1 in Equation 3 yields:

$$S_A(f) = \frac{\sin[\pi \cdot f \cdot (2 \cdot \tau_2 - T_0/2)]}{\pi \cdot f} \quad (6)$$

Summing Equations (4), (5), and (6), the frequency spectrum of the step-approximated transmit waveform, $S_2(f)$ is:

$$\begin{aligned} S_2(f) &= S_A(f) + S_B(f) + S_C(f) \\ &= \frac{2\sin(\pi f T_0/2)}{\pi f} \cdot [1 - \cos(2\pi f \tau_2)] \end{aligned} \quad (7)$$

In particular, the fundamental frequency peak is located at $f=F_0=1/T_0$. Substituting $f=F_0$ into Equation 7, the peak value yields:

$$S_2(F_0) = \frac{2T_0}{\pi} \cdot [1 - \cos(2\pi \frac{\tau_2}{T_0})] \quad (8)$$

Referring to Equation 7 again, the even harmonics are even multiples of the fundamental. Thus, the even harmonics frequencies, F_{2n} , can be determined as $F_{2n}=2nF_0=2n/T_0$, where $n=1, 2, 3$, etc. Inserting $f=F_{2n}$ into the argument of the sine function of expression (7) yields $\sin(\pi f T_0/2)=\sin(\pi n)=0$. Therefore, satisfying Formula 1, the spectrum of the transmit waveform of FIG. 3a contains no even harmonics.

The techniques of the present invention may allow suppressing a range of frequencies adjacent to the second harmonic. To confirm this analytically, it is noted that the term in square brackets of Equation 7 is zeroed if the cosine argument is equal to $2n\pi$. This occurs at the frequencies $f=F_{ABSORPTION}(n)$ satisfying the condition $2\pi f \tau_2=2n\pi$. Thus, $F_{ABSORPTION}(n)=n/\tau_2$. For example, by selecting $\tau_2=3T_0/8=3/8F_0$, absorption lines of the transmit spectrum are given by:

$$F_{ABSORPTION}(n) = \frac{8nF_0}{3} \quad (9)$$

As shown in FIG. 2, the first absorption line is located at $F_{ABSORPTION}(1)=8F_0/3 \approx 2.7 \cdot F_0$. Thus, the transmit sequence at the present invention may provide bandlimited spectrum and good range resolution. Furthermore, its spectrum comprises no second order harmonics of the fundamental.

The method of generating an ultrasonic transmit waveform is illustrated by the graphs of FIGS. 5a through 5e, in which time is plotted on the X-axis and voltage on the Y-axis. Time is measured in units of fractions of the period, T_0 , of the fundamental frequency F_0 . A first, second, and third unipolar base waveforms of unity amplitude having the above-defined temporal characteristics are respectively shown in the graphs of FIGS. 5a through 5c. To provide a zero-DC transmit waveform, the first base waveform is inverted as shown in the graph of FIG. 5d. Then, the inverted first, second, and third base waveforms are summed providing the proposed approximation of Gaussian modulated cosines as depicted in the graph of FIG. 5e.

In an alternative embodiment, the transmit waveform can be arranged by first summing the second and third base waveforms and subsequent subtracting the first base waveform from the obtained sum.

Low-Distortion Ultrasound Transmitter

FIG. 4 is a block diagram illustrating a medical ultrasonic imaging system 400. The system 400 comprises a controller 401, a multi-channel transmit and receive beamformers (402 and 408, respectively), a plurality of transmit/receive (T/R) switches 404, an array of transducers 406, and an image processor 410.

The insonification of a body structure is provided by the transmit beamformer 402 that applies respective transmit waveforms via the transmit/receive (T/R) switches 404 to the transducer array 406 in response to the controller 401. (Although the imaging system 400 is described for transmitting waveforms to and receiving waveforms from a body structure, the imaging system and the elements thereof may be used with other structures and in other systems.)

Each channel of the transmit beamformer 402 comprises a transmitter and a source of sampled waveform information representative of the desired transmit waveform. To steer and focus the transmit beam at a particular focal position, the transducers 406 are to be excited with different time delays. This is achieved by applying per-channel delay to the desired transmit waveform. Further details on beamforming can be found in foregoing section.

During receive, the transducers 406 detect echoes from body structures. The receive waveforms are applied via the transmit/receive switches 404 to a multi-channel receive beamformer 408, which applies suitable delays and filters to create a coherent sum for selected points along the spatial axis for application to an image processor 410 in response to the controller 401.

FIG. 6 is a block diagram illustrating a first embodiment of a single transmit channel transmitter 600 capable of being incorporated into the beamformer 402 for providing the beamforming of the present invention. The transmitter 600 comprises a power amplifier 610, a waveform generator 620, a phase-locked loop (PLL) 630, three programmable current drivers 650, and a digital-to-analog converter (DAC) 670. In one embodiment, the programmable current drivers 650 are identical. The interface of the transmitter 600 comprises a clock terminal 660, a triggering terminal 662, a reference voltage input 664, and two command ports, 666 and 668, responsive to receive beam formation data (focusing and apodization, respectively) in a digital format.

The power amplifier 610 may be a conventional transmitter-coupled class B push-pull transistor amplifier. The

transistors of the power amplifier **610** operate in a common-gate (or common-base) mode providing essentially low input impedance at their sources (or emitters). The current drivers **650** feed the power amplifier **610** via respective outputs **652**. A low input impedance of the amplifier **610** enables direct summing of two currents provided by those drivers **650** responsible for the second and third base waveforms (waveforms **5b** and **5c**, respectively,) as shown in FIG. **5**.

The phase locked loop **630** includes a voltage controlled oscillator (VCO) **632**, a frequency divider **634** (such as a twisted ring counter) for frequency-dividing an output from the VCO **632**, a phase-frequency detector **636** for comparing an output from the frequency divider **634** with a phase of an external reference signal applied via the clock terminal **660**, a charge pump and filter **638** for controlling the oscillator frequency of the VCO **632** on the basis of an output from the phase frequency detector **636**, and a multiplexer **639** for selecting a phase of the oscillator frequency. In one embodiment, the frequency divider **634** comprises a 2^{N-1} -stage (N is an even integer) twisted ring counter providing 2^N phase-shifted clock lines from inverted and non-inverted outputs, which are sequentially coupled to the inputs of the multiplexer **639** in ascending order of the value of phase shift.

The waveform generator **620** includes three blocks **622**, one for the base waveforms, and an address counter **626**. Each of the blocks **622** stores a 4-bit length binary word (i.e., 16 in decimal) as depicted in FIG. **5**. (A 4-bit length binary word is for illustrative purposes. Other numbers of bits may be used.) When a block **622** is read with an $8 \times F_0$ clock, the resulting sequence defines a waveform having $2T_0$ in duration. To generate the first, second, and third base waveforms synchronously with a phase-shifted reference clock, the address counter **626** is fed by the multiplexer **639**. The process of firing is initiated via the triggering terminal **662**. The base waveforms are outputted through data ports **624** and respectively applied to the current drivers **650**.

The DAC **670** is controlled by a digital code loaded into the port **668**. Accordingly, the DAC output **654** becomes a product of a voltage applied to the reference input **664** and the digital code. Thus, the DAC **670** generates a scaled voltage in response to a code provided by the command register.

FIG. **8** is a circuit diagram illustrating the ON/OFF switchable current driver **650** shown in FIG. **6**. The current driver **650** comprises a logical inverter **802** having an open-drain output **808**, a resistor **804**, and a MOSFET transistor **806** having a gate, drain and source. The transistor source is coupled to the open-drain output through the resistor **804**. Referring to FIG. **6**, the transistor gate **810** is fed by the DAC output **654**. In an alternative embodiment, a bipolar transistor in a common base configuration may be used. Regardless on the implementation, the current flowing through the resistor **804** in the ON state is proportional to the DAC output voltage denoted as REF in FIG. **6**. Signals for controlling ON-OFF states of the current driver **650** are produced by the waveform generator **620** (FIG. **6**) and applied to the inverter input **812**.

For low levels of the DAC output, the threshold voltage tolerance of the transistor **806** may degrade the accuracy of apodization. In view of that, the second embodiment shown in FIG. **7** provides a modified transmitter architecture.

FIG. **7** is a block diagram illustrating a second embodiment of a single transmit channel transmitter **700** capable of being incorporated into the beamformer **402** for providing the beamforming of the present invention. The transmitter **700** comprises a power amplifier **710**, a waveform generator **720**, and a PLL **730**, which are identical to the respective elements **610**, **620**, and **630** shown in FIG. **6**. Similarly, the interface of the second embodiment includes a clock terminal **760**, a

triggering terminal **762**, a reference input **764**, and two command ports, **766** and **768**. The difference between the above embodiments lies in the arrangement of current drivers **750**.

FIG. **9** depicts a circuit diagram of the current driver **750** shown in FIG. **7**. The programmable current driver **750** comprises a digitally programmable resistor (DPR) **904** with enable and a MOSFET transistor **906**. The transistor **906** is arranged with its gate **918** coupled to the reference input **664**, the source coupled to a common node **908** of the programmable resistor **904**, and the drain to providing the driver output **916**. The programmable resistor **904** comprises a plurality of 2-input open-drain NAND gates **910** and a plurality of resistors **912**. The resistors **912** are binary weighted. Each resistor **912** is coupled between the open-drain output of a gate **910** and the common node **908**. A first input of each gate receives a respective bit of a binary word applied to the command port **668**. This binary word represents a desired resistance of the programmable resistor **904**.

All second inputs of each gate are coupled together exhibiting a node **914** and, thus, a logical "1" applied to the node enables conducting of the gates having a logical "1" on their first inputs. Therefore, the transistor **906** generates a current pulse whose timing is determined by the waveform generator **720**. In an alternative embodiment, thermometer coding scheme or its combination with binary techniques may be used. The amplitude of this pulse may be directly proportional to the reference signal and inversely proportional to the resistance.

Referring to FIG. **9**, programmable resistance is varied from $8R/15$ to $8R$. Thus, for a fixed voltage at the gate of the transistor **906**, the amplitude of the produced current pulses will approach the range of 24 dB. Other dynamic ranges, including lesser or larger ranges may be used. By any means, this range defines attainable amplitude resolution for apodization.

Beamforming

The two most common beamforming approaches are the time delay (shift) and phase shift. The time delay approach allows focusing and steering the beam by introducing per-channel time delays that are independent from the operating frequency and bandwidth. Instead of applying true time delays for each channel, the phase shift beamformer converts a required delay to an equivalent phase shift at a specified frequency. Since a phase-shift technique is adapted to form a beam at a predetermined frequency, the respective imaging systems are more narrowband than those employing time-delay beamformers.

An absolute time shift may be implemented by delaying the composed waveform or delaying a start of waveform generation. To delay the composed waveform, transmit beamformers may use field programmable gate arrays (FPGA) or first-in, first-out (FIFO) buffers for each channel. Delaying a start point of waveform generation is also provided on a per-channel basis but it consumes much less hardware resources.

Implementing the second method of the time shift, the absolute delay is programmed into the programmable delay counter. This counter counts a number of clock cycles associated with the absolute delay in response to a start-of-transmit signal (SOT). A transmit sequence is initiated at the end of the counting period. Thus, the accuracy of delay is defined by the counter clock rate.

Those experienced in the art understand that routing a plurality of highly sampled (e.g., broadband) SOT signals might be complex. For this reason, one embodiment of the present invention is described such that the applied SOT signal is produced with a $T_0/8$ sampling interval (a 45° sam-

pling in terms of phase), e.g., an ultrasound system incorporating the present invention would be responsible for merely coarse focusing.

To support fine focusing, the implemented PLLs 630 and 730 are configured to produce N (N is an even integer) phase-shifted clocks at the $8F_0$ rate. Thus, the phases of these clocks are evenly spaced within the 45° range. One of the above clocks is selected by the multiplexers 639 and 739 and used for timing the waveform generators 620 and 720. Consequently, the transmit waveforms may have N discrete positions relative to the one determined by the applied "coarse" SOT (or triggering) signal. Since the adjacent discrete positions are shifted in time by $T_0/8N$, the beamformer phase resolution yields $45^\circ/N$ in phase. For instance, implementing an 8-stage twisted ring counter, a 2.8° phase accuracy can be achieved.

Some features of the above embodiments of the present invention can be summarized as follows:

1. The transmit waveform may be characterized by bandlimited spectrum and low level of second order harmonics while retaining the duration of the transmitting within two carrier cycles.
2. The ultrasound transmitters support digitally controlled transmit apodization and fine focusing.
3. The embodiments may provide time-independent output impedance.

While the invention has been described above by reference to various embodiments, it would be understood that many changes and modifications could be made without departing from the scope of the invention. For example, different waveform generators, current drivers, switches, or output amplifier configurations may be used. It is therefore intended that the foregoing detailed description be understood as an illustration of the presently preferred embodiments of the invention, and not as a definition of the invention. It is only the following claims or added claims, including all equivalents, are intended to define the scope of this invention.

What is claimed is:

1. A method of transducer excitation in a medical ultrasound imaging system having a waveform generator and a transducer, the method comprising the steps of:

- (a) generating by the waveform generator an excitation waveform signal with three base waveforms (A, B, C), each of which is a unipolar pulse, wherein the waveform signal represents a gated, stepped approximation of a Gaussian envelope multiplied by a cosine carrier signal, with said three base waveforms satisfying the relationships of:

voltage-time product of positive (A+B)=negative C, where C comprises two pulses having the same duration;

$t_1=2*t_2-T_0/2$, where t_1 is the duration of the A pulse, t_2 is the duration of each of the pulses of C, and $T_0/2$ is the duration of the B pulse and T_0 is the fundamental frequency;

- (b) selecting a carrier frequency signal, F_0 , in accordance with a fundamental frequency of the transducer, $F_0=1/T_0$; and

- (c) applying the excitation waveform signal to the transducer.

2. The method of claim 1 wherein the step (a) further comprises constructing the excitation waveform within an excitation interval of $2 T_0$.

3. The method of claim 1 wherein the step (a) further comprises constructing the excitation waveform as a bipolar waveform.

4. The method of claim 1 wherein the step (a) further comprises constructing the excitation waveform as a zero-DC waveform.

5. The method of claim 1 wherein the step (a) further comprises synthesizing the excitation waveform to have no even harmonic content.

6. The method of claim 1 wherein the step of constructing an excitation waveform includes a step of combining said base waveforms, said combining step further comprises inverting of the polarity of the first waveform.

7. A method of transducer excitation in a medical ultrasound imaging system having a waveform generator and a transducer, the method comprising the steps of:

- (a) generating by the waveform generator an excitation waveform signal with three base waveforms (A, B, C), each of which is a unipolar pulse, wherein the waveform signal represents a gated, stepped approximation of a Gaussian envelope multiplied by a cosine carrier signal, with said three base waveforms satisfying the relationships of:

voltage-time product of positive (A+B)=negative C, where C the first base waveform comprises first and second pulses having the same duration of $T_1=0.375 T_0$;

wherein said second base waveform (A) and said third base waveform (B) has the same duration with the center of said second base waveform (A) shifted from the center of said third base waveform (B);

- (b) selecting a carrier frequency signal, F_0 , in accordance with a fundamental frequency of the transducer, $F_0=1/T_0$; and

- (c) applying the excitation waveform signal to the transducer.

8. The method of claim 7 wherein said first and second pulses of said first base waveform are unipolar and characterized by a uniform amplitude.

9. The method of claim 7 wherein the second pulse of said first base waveform is shifted from the first pulse in time, said shift is equal to $T_0/2$;

and wherein the center of said first base waveform is over the center of the excitation interval.

10. The method of claim 7 wherein the second and third base waveforms are unipolar, uniform amplitude pulses having duration of $T_1=0.375 T_0$; and

wherein the center of the second base waveform (A) is shifted $T_0/16$ in time from the center of the excitation interval in the backward direction; and

the center of the third base waveform (B) is shifted $T_0/16$ in time from the center of the excitation interval in the forward direction.

11. An ultrasound transmitter for generating an excitation waveform with programmable apodization and time (phase) shift, the transmitter comprising:

a phase locked loop (PLL) generating a clock signal with user-selectable phase shift in response to a reference clock having a frequency $8 \times F_0$, where F_0 is a fundamental frequency of the transducer;

a waveform generator having a plurality of waveform outputs for providing respective waveforms in response to a trigger signal and the clock signal, and constructing an excitation waveform, with three base waveforms (A, B, C), each of which is a unipolar pulse, with said three base waveforms satisfying the relationships of:

voltage-time product of positive (A+B)=negative C, where C comprises two pulses having the same duration;

wherein the waveform represents a gated, stepped approximation of a Gaussian envelope multiplied by a cosine

11

carrier; selecting the carries frequency, F_o , in accordance with a fundamental frequency of the transducer; first, second and third programmable current drivers each having a waveform input and having a current output, and providing current signals from the current output in response to a voltage reference and a respective waveform applied to a corresponding waveform input from a corresponding waveform output of the waveform generator;

a power amplifier for generating an excitation waveform in response to current signals on the current outputs of the current drivers; and

a first and second command registers controlling said apodization factor and time (phase) shift of the excitation waveform.

12. The ultrasound transmitter of claim 11, wherein: the waveform generator stores and reads the first, second and third base waveforms via a first, second and third data ports, said waveform generator comprises a 3×16 addressable matrix of binary data and a 4-bit address counter which maintains said addressing, and wherein: said counter further comprises timing and firing inputs, said timing and firing inputs are respectively coupled to a multiplexer output and a triggering terminal.

13. The ultrasound transmitter of claim 11, wherein the power amplifier is a transformer-coupled class B push-pull amplifier comprising first and second high-voltage transistors, each of said first and second high-voltage transistors having a gate, source, and drain, both transistors coupled in a common-gate configuration, and wherein the source of the first high-voltage transistor is coupled to the current output of the first current driver, the source of the second high-voltage transistor and the current outputs of said second and third current drivers are coupled together.

14. The ultrasound transmitter of claim 11, wherein the PLL includes a voltage controlled oscillator (VCO), a frequency divider for frequency-dividing an output from the VCO, a phase-frequency detector for comparing an output from the frequency divider with a phase of said reference clock, a charge pump for controlling the VCO frequency on the basis of an output from said phase detector, and a multiplexer and

12

wherein said frequency divider comprises a 2^{N-1} -stage (N is an even integer) twisted ring counter providing 2^N phase-shifted clock lines from inverted and non-inverted outputs, which are sequentially coupled to the inputs of said multiplexer in ascending order of the value of phase shift, said multiplexer having 2^N inputs, an output providing said clock signal and a select port coupled to said first command register.

15. The ultrasound transmitter of claim 11, wherein each of said first, second and third current drivers further comprises a low-voltage transistor, said transistor having a gate, a source, and a drain supplying the current driver output, the gates of said low-voltage transistors of the first, second and third current drivers being coupled together with the reference voltage source.

16. The ultrasound transmitter of claim 15, wherein each of said first, second and third current drivers further comprises a logical inverter and a resistor, said logical inverter having an input node and an open-drain output, said resistor coupled between said open-drain output and the source of said low-voltage transistor, said input nodes are respectively coupled to the first, second and third data ports of said waveform generator.

17. The ultrasound transmitter of claim 15, wherein said reference voltage source comprises a digital-to-analog converter (DAC) arranged to generate a scaled voltage in response to a code provided by the second command register.

18. The ultrasound transmitter of claim 15, wherein each of said first, second and third current drivers further comprises a plurality of binary weighed resistors, each having two terminals, and a plurality of NAND gates, each having two inputs and an open-drain output.

19. The ultrasound transmitter of claim 18, wherein: the first terminals of said resistors are respectively coupled to the open drain outputs of said NAND gates; the second terminals of said resistors are coupled together with the source of said low-voltage transistor; and the first inputs of said NAND gates are coupled to corresponding bit lines of the second command register.

20. The ultrasound transmitter of claim 19, wherein the second inputs of the NAND gates of said first, second and third current drivers are respectively coupled to the first, second and third data ports of said waveform generator.

* * * * *

专利名称(译)	用于医学超声成像中的换能器激发的方法和装置		
公开(公告)号	US8147409	公开(公告)日	2012-04-03
申请号	US12/053235	申请日	2008-03-21
[标]申请(专利权)人(译)	超科有限公司		
申请(专利权)人(译)	Supertex公司, 公司		
当前申请(专利权)人(译)	微芯科技股份有限公司.		
[标]发明人	SHIFRIN LAZAR A		
发明人	SHIFRIN, LAZAR A.		
IPC分类号	A61B8/00		
CPC分类号	G01S7/52046 G01S15/895 G10K11/346		
助理审查员(译)	LUONG, PETER		
优先权	60/920606 2007-03-29 US		
其他公开文献	US20080242987A1		
外部链接	Espacenet USPTO		

摘要(译)

一种医学超声成像中换能器激发的方法。基于高斯调制余弦的阶梯近似，发射波形提供带限频谱和低水平的二阶谐波，同时在两个载波周期内保持发射的持续时间。波形被构造为四个单极矩形脉冲的线性组合，其单位幅度。此外，所描述的实施例支持数字控制的发送切趾和聚焦。

