



US 20050054933A1

(19) **United States**

(12) **Patent Application Publication**
Mamayek

(10) **Pub. No.: US 2005/0054933 A1**

(43) **Pub. Date: Mar. 10, 2005**

(54) **DYNAMICALLY CONFIGURABLE
ULTRASOUND TRANSDUCER WITH
INTERGRAL BIAS REGULATION AND
COMMAND AND CONTROL CIRCUITRY**

continuation of application No. 09/454,128, filed on
Dec. 3, 1999, now Pat. No. 6,499,348.

Publication Classification

(75) Inventor: **Donald S. Mamayek**, Mountain View,
CA (US)

(51) **Int. Cl.⁷ A61B 8/14**

(52) **U.S. Cl. 600/459**

Correspondence Address:

ORRICK, HERRINGTON & SUTCLIFFE, LLP
4 PARK PLAZA
SUITE 1600
IRVINE, CA 92614-2558 (US)

(57) **ABSTRACT**

(73) Assignee: **SCIMED LIFE SYSTEMS, INC.**

A dynamically configurable ultrasound transducer element and related circuits and methods. The transducer may comprise an array of capacitive transducer elements, a row decoder coupled to said array of capacitive transducer elements, a column decoder coupled to said array of capacitive transducer elements, a bias voltage source coupled to said row decoder, and a driving signal source coupled to said column decoder. Preferably, a master clock also is provided to allow for a synchronization of signals between the row decoder and column decoder.

(21) Appl. No.: **10/971,457**

(22) Filed: **Oct. 21, 2004**

Related U.S. Application Data

(63) Continuation of application No. 10/219,596, filed on
Aug. 14, 2002, now Pat. No. 6,826,961, which is a

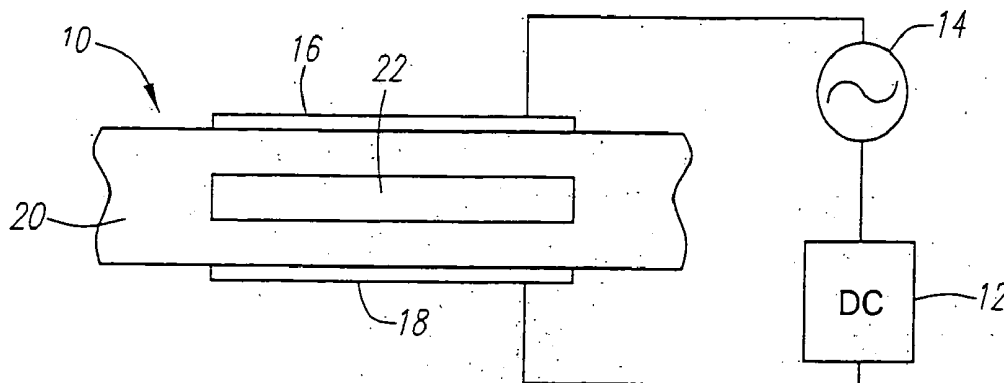

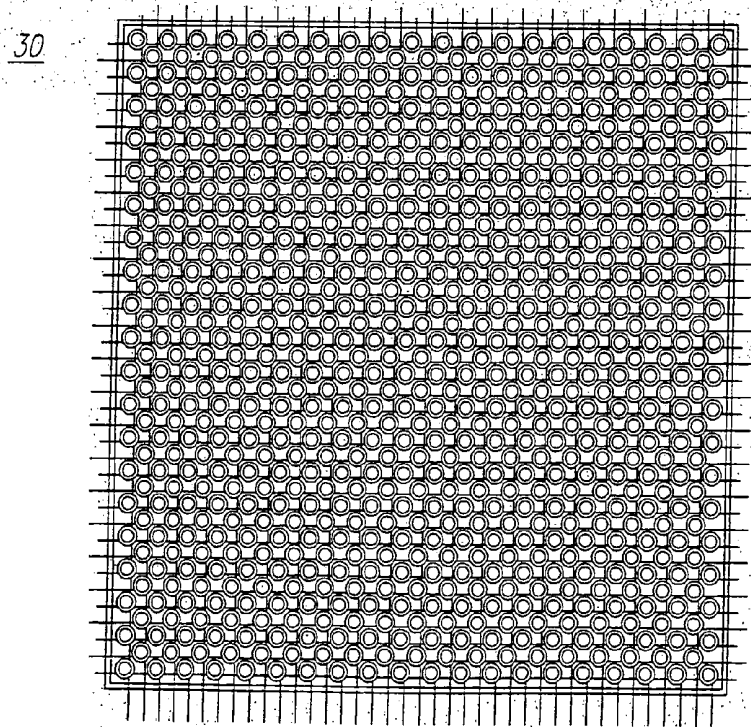
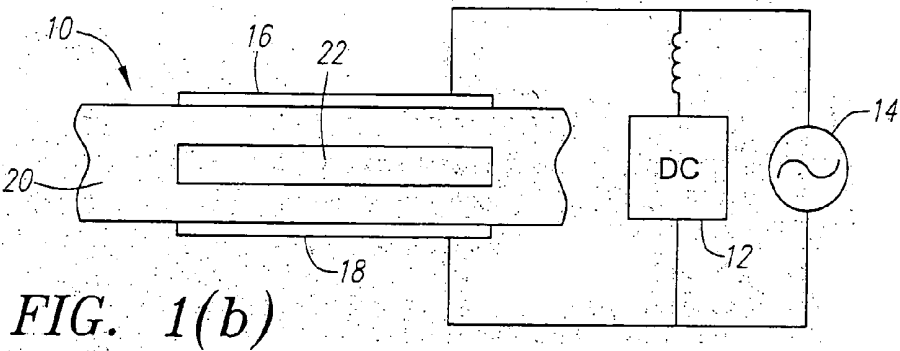
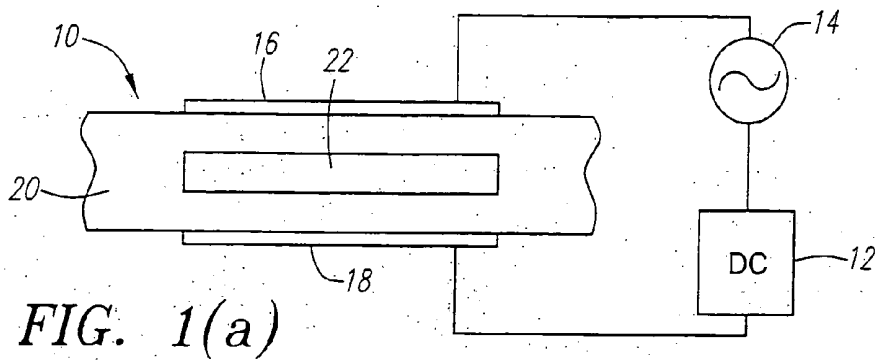

FIG. 2

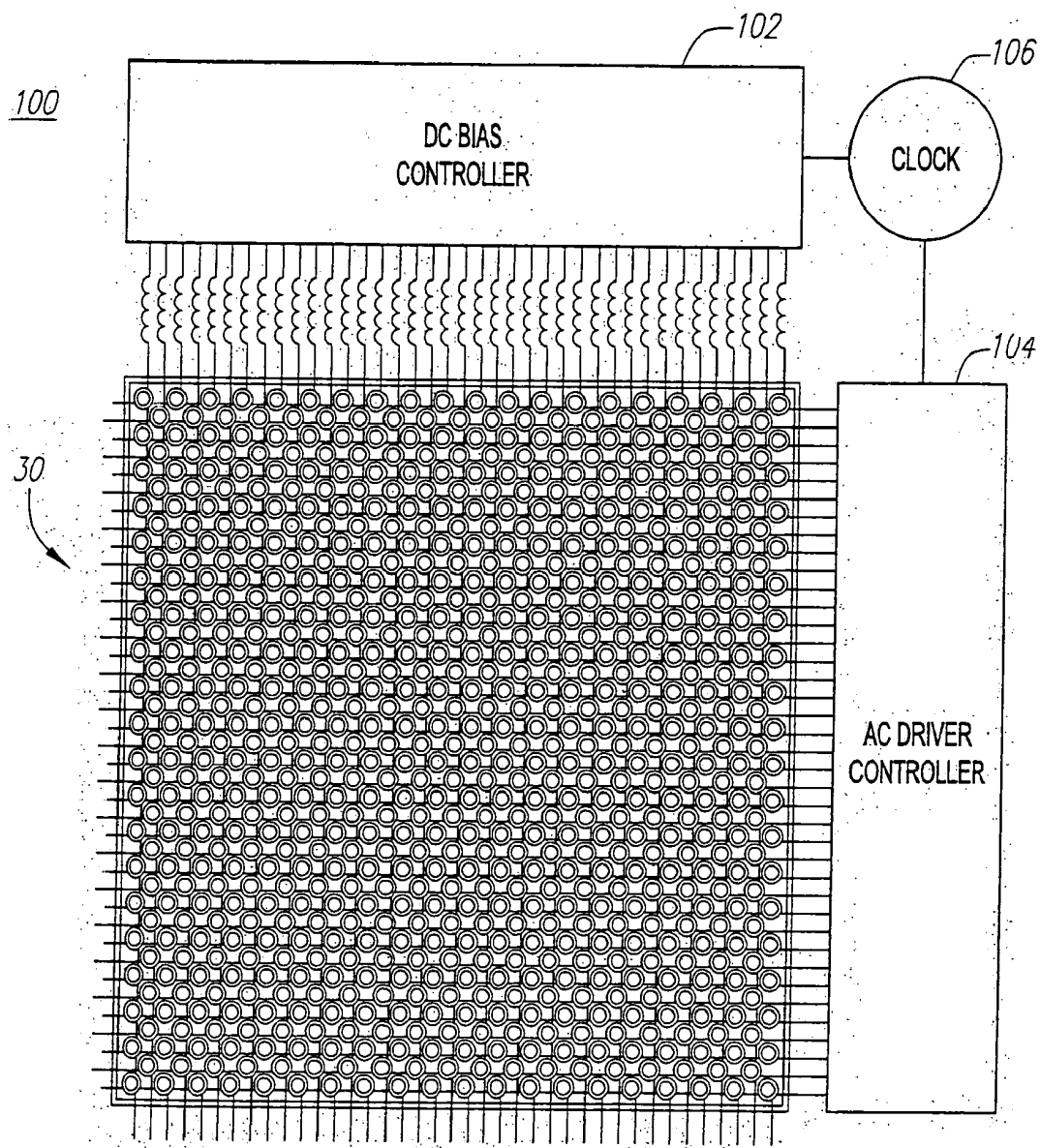

FIG. 3

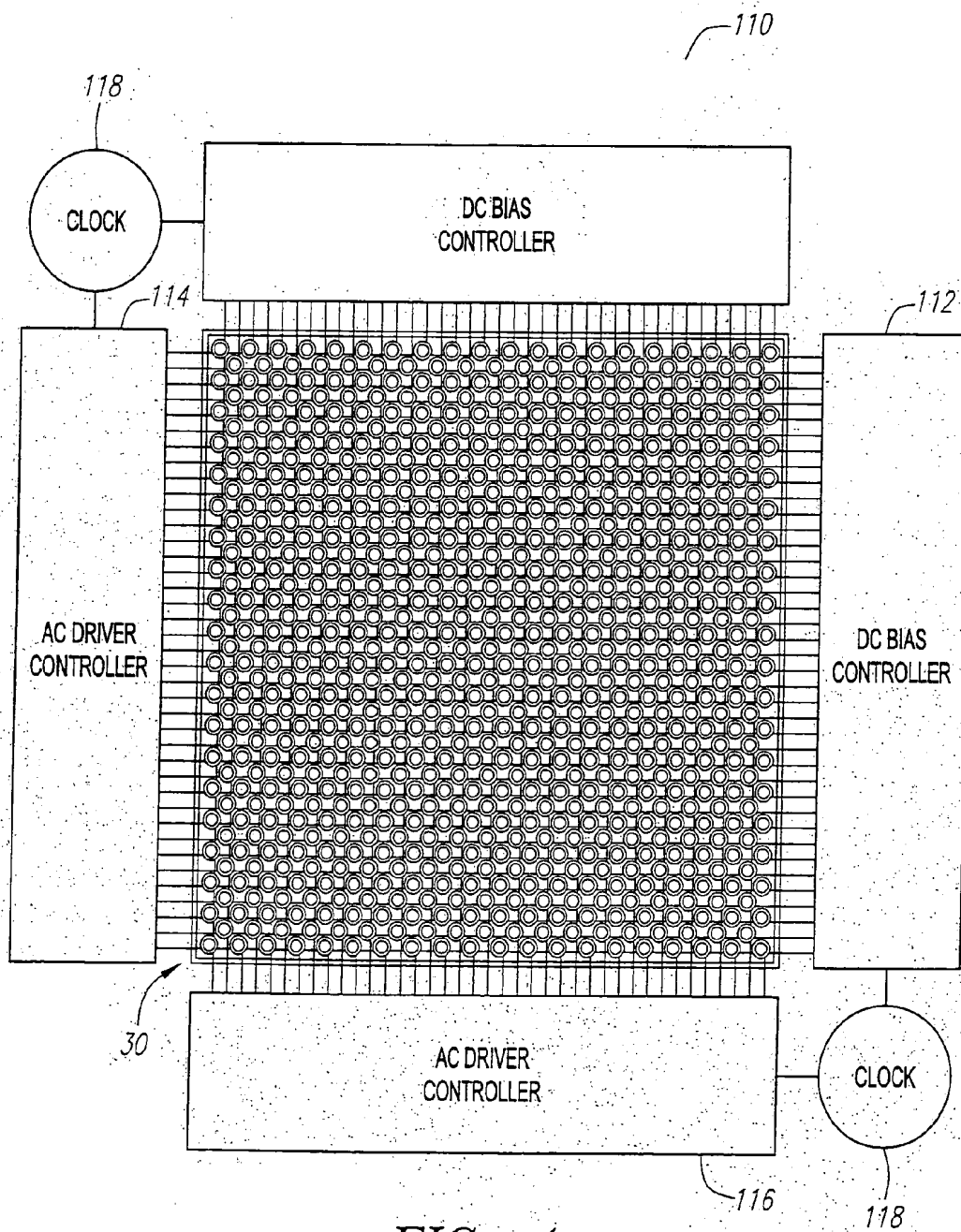

FIG. 4

	ON	ON	ON	ON	ON	ON	ON	ON
ON	X	X	X	X	X	X	X	X
ON	X	X	X	X	X	X	X	X
ON	X	X	X	X	X	X	X	X
ON	X	X	X	X	X	X	X	X
ON	X	X	X	X	X	X	X	X
ON	X	X	X	X	X	X	X	X
ON	X	X	X	X	X	X	X	X
ON	X	X	X	X	X	X	X	X

FIG. 5(a)

	ON	OFF	ON	OFF	ON	OFF	ON	OFF	ON
ON	X		X		X		X		X
ON	X		X		X		X		X
ON	X		X		X		X		X
ON	X		X		X		X		X
ON	X		X		X		X		X
ON	X		X		X		X		X
ON	X		X		X		X		X
ON	X		X		X		X		X

FIG. 5(b)

				DC					
	ON	OFF	OFF	OFF	OFF	OFF	OFF	OFF	ON
ON	X	X	X	X	X	X	X	X	X
OFF	X								X
OFF	X								X
OFF	X								X
OFF	X								X
AC	OFF	X		X	X				X
OFF	X			X	X				X
OFF	X								X
OFF	X								X
OFF	X								X
ON	X	X	X	X	X	X	X	X	X
	ON	OFF	OFF	ON	ON	OFF	OFF	OFF	ON

FIG. 5(c)

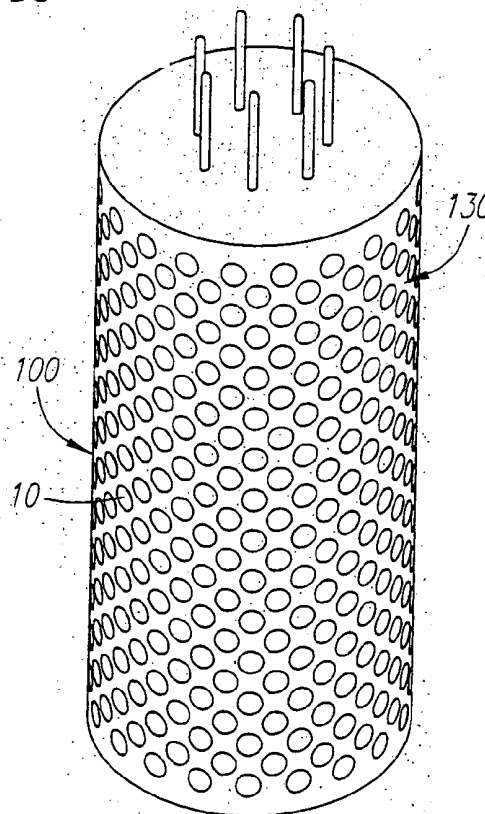

FIG. 6

**DYNAMICALLY CONFIGURABLE ULTRASOUND
TRANSDUCER WITH INTEGRAL BIAS
REGULATION AND COMMAND AND CONTROL
CIRCUITRY**

**CROSS REFERENCE TO RELATED
APPLICATIONS**

[0001] This application is a continuation of co-pending U.S. patent application Ser. No. 10/219,596, filed Aug. 14, 2002, which is a continuation of U.S. patent application Ser. No. 09/454,128, filed Dec. 3, 1999, now U.S. Pat. No. 6,499,348, the entirety of which disclosures are incorporated herein by reference for all purposes.

FIELD OF THE INVENTION

[0002] The present invention relates generally to transducers for ultrasound imaging systems and, more particularly, to dynamically configurable transducers for such systems.

BACKGROUND OF THE INVENTION

[0003] Recently, substantial attention has been directed toward the development and implementation of internal and external ultrasound imaging systems.

[0004] Intraluminal, intracavity, intravascular, and intracardiac treatment and diagnosis of medical conditions utilizing minimally invasive procedures is an effective tool in many areas of medical practice. These procedures typically are performed using imaging and treatment catheters that are inserted percutaneously into the body and into an accessible vessel, such as the femoral artery, of the vascular system at a site remote from a region of the body to be diagnosed and/or treated. The catheter then is advanced through the vessels of the vascular system to the region of the body to be diagnosed and/or treated, such as a vessel or an organ. The catheter may be equipped with an imaging device, typically an ultrasound imaging device, which is used to locate and diagnose a diseased portion of the body, such as a stenosed region of an artery.

[0005] Intravascular imaging systems having ultrasound imaging capabilities generally are known. For example, U.S. Pat. No. 4,951,677, issued to Crowley, the disclosure of which is incorporated herein by reference, describes such an intravascular ultrasound imaging system. An ultrasound imaging system typically contains some type of control system, a drive shaft, and a transducer assembly including an ultrasound transducer. The transducer assembly includes a transducer element and is coupled to the control system by the drive shaft. The drive shaft typically includes an electrical cable, such as coaxial cable, for providing electrical communication between the control system and the ultrasound transducer.

[0006] In operation, the drive shaft and the transducer assembly are inserted, usually within a catheter, into a patient's body and may be positioned near a remote region of interest. To provide diagnostic scans of the remote region of interest within, for example, a coronary blood vessel, the ultrasound transducer may be positioned near or within the remote region of the patient's body. Diagnostic scans are created when the control system alternately excites and allows sensing by the ultrasound transducer. The control system may direct the ultrasound transducer toward or away

from an area of the remote region. When the ultrasound transducer is excited, a transmitting/receiving surface of the transducer element creates pressure waves in the bodily fluids surrounding the ultrasound transducer. The pressure waves then propagate through the fluids within the patient's body and ultimately reach the region of interest, forming reflected pressure waves. The reflected pressure waves then return through the fluids within the patient's body to the transmitting/receiving surface of the transducer element, inducing electrical signals within the transducer element. The control system then may collect the induced electrical signals and may reposition the ultrasound transducer to an adjacent area within the remote region of the patient's body, again exciting and sensing the transducer element. This process may continue until the remote region has been examined sufficiently and a series of induced signals has been collected. The control system then may process the series of induced signals to derive a diagnostic scan and may display a complete image of the diagnostic scan.

[0007] Those skilled in the art will appreciate that the type of transducer that may be required, or preferred, for a particular procedure often will vary depending upon the type of procedure to be performed. For example, for some procedures it may be desirable to utilize a transducer with a long, or extended focus, such that areas of tissue remote from the transducer may be imaged clearly, whereas in other procedures it may be desirable to utilize a transducer with a relatively short focus to image, for example, areas of tissue in relatively close proximity to the transducer. Those skilled in the art also will appreciate that, depending upon the type of procedure to be performed, it may be desirable to utilize transducers having the ability to implement certain scanning functions. Finally, those skilled in the art will appreciate that in many imaging systems, such as those described above, a transducer will be rotated to perform a scanning function, and that the provision of such capabilities may add significantly to the cost of an imaging system.

[0008] In view of the foregoing, it is believed that a need exists for an improved ultrasound transducer that overcomes the aforementioned obstacles and deficiencies of currently available ultrasound transducers. It is further believed that a need exists for a transducer that is dynamically configurable, such that its performance may be dynamically altered to meet the needs of a given application.

BRIEF SUMMARY OF THE INVENTION

[0009] In one innovative aspect, the present invention is directed toward a dynamically configurable ultrasound transducer.

[0010] In one presently preferred embodiment, the transducer may comprise an array of capacitive transducer elements, a row decoder coupled to said array of capacitive transducer elements, a column decoder coupled to said array of capacitive transducer elements, a bias voltage source coupled to said row decoder, and a driving signal source coupled to said column decoder. Preferably, a master clock also is provided to allow for a synchronization of signals between the row decoder and column decoder.

[0011] Using the row decoder, a bias voltage may be applied to selected rows of capacitive transducer elements provided within the array to enable the function of those elements, and thereafter, a driving signal (or stimulus signal)

may be supplied to selected columns of capacitive transducer elements provided within the array. In this fashion, numerous configurations of capacitive transducer elements may be activated for transmitting and receiving ultrasonic waves within a predetermined medium.

[0012] In another presently preferred embodiment, a dynamically configurable ultrasound transducer may comprise an array of capacitive transducer elements, a first pair of row and column decoders for applying a DC bias signal to selected capacitive transducer elements within the array, a second pair of row and column decoders for applying an AC driving signal to selected capacitive transducer elements within the array, and a clock for providing a master clock signal to the first and second pairs of row and column decoders.

[0013] Those skilled in the art will appreciate that different control circuits may be utilized within a dynamically configurable transducer in accordance with the present invention depending upon the performance characteristics needed from the transducer. For example, in alternative embodiments a DC bias signal may be applied to all of the capacitive transducer elements within an array, and a single row or column decoder could be utilized to selectively apply an AC driving signal to desired rows, or columns, with the array. Alternatively, a single row or column decoder circuit could be used to selectively couple both the DC bias signal and the AC driving signal to desired rows, or columns, of transducer elements within the array.

[0014] In another innovative aspect, the present invention is directed toward systems and methods for dynamically configuring an ultrasound transducer. Within such methods, a bias voltage, or a combination of a bias voltage and driving voltage, may be used to selectively activate and deactivate capacitive transducer elements provided within an array of such elements. Thus, using systems and methods in accordance with the present invention, it is possible to activate selected rows or columns of capacitive transducer elements in a predetermined sequence within a transducer element array or, alternatively, to enable and activate predetermined geometric configurations of the capacitive transducer elements within the array and in a predetermined sequence. Thus, those skilled in the art will appreciate that a dynamically configurable ultrasound transducer in accordance with the present invention may be configured in numerous ways, depending on a desired application or use of the transducer.

[0015] Other objects and features of the present invention will become apparent from consideration of the following description taken in conjunction with the accompanying drawings.

BRIEF DESCRIPTION OF THE DRAWINGS

[0016] FIG. 1(a) is an illustration of a capacitive transducer element and related DC bias and AC driver signal sources in accordance with a preferred form of the present invention.

[0017] FIG. 1(b) is an illustration of an alternative configuration of a capacitive transducer element and related DC bias and AC driver signal sources in accordance with a preferred form of the present invention.

[0018] FIG. 2 is an illustration of an array of capacitive transducer elements in accordance with a preferred form of the present invention.

[0019] FIG. 3 is an illustration of a dynamically configurable ultrasound transducer including command and control circuitry in accordance with the present invention.

[0020] FIG. 4 is an illustration of an alternative embodiment of a dynamically configurable ultrasound transducer including command and control circuitry in accordance with the present invention.

[0021] FIGS. 5(a)-5(c) illustrate how capacitive transducer elements within an array in accordance with the present invention may be selectively activated to achieve desired transducer configurations.

[0022] FIG. 6 is an illustration of a cylindrical ultrasound transducer in accordance with one form of the present invention.

DETAILED DESCRIPTION OF THE INVENTION

[0023] Turning now to the drawings, FIGS. 1(a) and 1(b) provide illustrations alternative embodiments of a capacitive transducer element 10, and related DC and AC signal sources 12 and 14, that may be used within a dynamically configurable ultrasound transducer 100 (shown in FIGS. 3 and 4) in accordance with the present invention. As shown, the capacitive transducer element 10 may comprise a pair of electrode plates 16 and 18 and a substrate 20. The substrate 20 is configured such that an open space 22 is provided between the electrode plates 16 and 18. A DC bias signal source 12 and an AC driving signal source 14 preferably are coupled to the electrode plates 14 and 16. The DC bias signal source 12 enables the operation of the capacitive transducer element 10, and the frequency of operation of the capacitive transducer element is determined by the AC driving signal source 14. Accordingly, those skilled in the art will appreciate that by varying the frequency of the AC driving signal source 14, it is possible to vary certain limits the frequency of operation of the capacitive transducer element. The limits of operation are imposed by the physical structure and acoustic capabilities of a given transducer element 10.

[0024] FIG. 2 provides an illustration of an array 30 of capacitive transducer elements 10. An array 30 of capacitive transducer elements 10 may be obtained, for example, from Sensant Corporation of San Jose, Calif.

[0025] Turning now to FIGS. 3 and 4, in one presently preferred form (shown in FIG. 3) a dynamically configurable ultrasound transducer 100 may comprise an array 30 of capacitive transducer elements 10, a DC bias controller 102, an AC driver controller 104, and a master clock 106. The DC bias controller 102 is connected to a DC bias signal source 12 (shown, for example, in FIGS. 1(a) and 1(b)), and the AC driver signal controller 104 is connected an AC driver signal source 14 (also shown in FIGS. 1(a) and 1(b)). Those skilled in the art will appreciate that the DC bias controller 102 may be utilized to enable the operation of various rows or columns of capacitive transducer elements 10 within the array 30, and that the AC driver controller may be utilized to deliver an AC driver signal having a predetermined, or variable, frequency to selected rows or columns of capacitive transducer elements 10 within the array 30.

[0026] Turning now to FIG. 4, in another presently preferred embodiment, a dynamically configurable ultrasound transducer 100 in accordance with the present invention may

comprise an array **30** of capacitive transducer elements **10**, first and second DC bias controllers **110** and **112**, first and second AC driver signal controllers **114** and **116**, and a master clocking circuit **118** coupled to the various controllers **110-116**. Preferably, array **30** of capacitive transducer elements **10**, the first and second DC bias controllers **110** and **112**, the first and second AC driver signal controllers **114** and **116**, and the master clocking circuit **118** are formed on or within a single substrate or comprise a single overall unit. The construction, operation, and implementation of clocking circuits, row decoders, and column decoders are believed to be well known in the art. Thus, the specific structures of the DC bias controllers **102**, **110**, and **112**, AC driving signal controllers **104**, **114**, and **116**, and clock circuits **106** and **118** are not described herein in detail.

[0027] Turning now also to FIGS. **5(a)-5(c)**, those skilled in the art will appreciate that by utilizing a dynamically configurable ultrasound transducer **100** in accordance with the present invention, it is possible to achieve numerous transducer configurations and, if desired, to vary those configurations in real time. For example, as shown in FIG. **5(a)** for some applications it may be desirable to enable the function of all of the capacitive transducer elements **10** within a given array **30** and to use the entire array **30** as an annular device. Alternatively, as shown in FIG. **5(b)** it may be desirable for certain ultrasound scanning procedures to enable rows or columns of transducer elements **10** in a synchronized fashion. Finally, in still other applications, it may be desirable to enable predetermined geometric configurations of the transducer elements **10** in a synchronized fashion. Moreover, by selectively enabling predetermined geometric patterns of transducer elements **10** in a synchronized fashion, variations in transmission and reception aperture sizes may be achieved, variations in the focal length of the transducer **100** may be achieved, the transducer **100** may be used as a phased array, and the transducer **100** may effect electronic scanning.

[0028] Those skilled in the art also will appreciate that by properly controlling the DC bias and AC driving signal controllers within a transducer **100** in accordance with the present invention, it is possible to operate the transducer **100** as an annular array device, a one dimensional (1D) array, a two dimensional (2D) array, or a three dimensional (3D) array.

[0029] Turning now to FIG. **6**, in a presently preferred embodiment, and ultrasound transducer **100** may take the form of an imaging cylinder, such that a plurality of capacitive transducer elements **10** are provided around the exterior surface **130** of the cylindrical structure, and the command and control circuits (not shown) may be provided within the core (not shown) of the cylindrical structure. Those skilled in the art will appreciate that an ultrasound transducer **100** configured in the manner illustrated in FIG. **6** might be used to effect radial ultrasonic imaging scans within, for example, the coronary artery of a patient without the use of transducer rotation hardware and related image artifact.

[0030] While the present invention is susceptible to various modifications and alternative forms, specific examples thereof have been shown by way of example in the drawings and are herein described in detail. It should be understood, however, that the invention is not to be limited to the particular forms or methods disclosed, but to the contrary,

the invention is to cover all modifications, equivalents, and alternatives falling within the spirit and scope of the appended claims.

What is claimed is:

1. A dynamically configurable ultrasound transducer comprising:

- an array of capacitive transducer elements,
- a first decoder coupled to said array of capacitive transducer elements,
- a second decoder coupled to said array of capacitive transducer elements,
- a DC bias voltage source coupled to said first decoder, and
- an AC driving signal source coupled to said second decoder.

2. The dynamically configurable ultrasound transducer of claim 1 further comprising a master clock coupled to said first decoder and said second decoder.

3. The dynamically configurable ultrasound transducer of claim 1, wherein said first decoder and second decoder comprise a row decoder and column decoder, respectively.

4. The dynamically configurable ultrasound transducer of claim 1, wherein said first decoder and second decoder comprise a column decoder and row decoder, respectively.

5. A dynamically configurable ultrasound transducer comprising:

- an array of capacitive transducer elements,
- a DC bias signal source coupled to said array of capacitive transducer elements,
- a first decoder coupled to said array of capacitive transducer elements, and
- an AC driving signal source coupled to said first decoder.

6. The dynamically configurable ultrasound transducer of claim 5 further comprising a master clock coupled to said first decoder.

7. The dynamically configurable ultrasound transducer of claim 5, wherein the first decoder comprises either a row decoder or a column decoder.

8. A dynamically configurable ultrasound transducer comprising:

- an array of capacitive transducer elements,
- an AC driving signal source coupled to said array of capacitive transducer elements,
- a first decoder coupled to said array of capacitive transducer elements, and
- a DC bias signal source coupled to said first decoder.

9. The dynamically configurable ultrasound transducer of claim 8 further comprising a master clock coupled to said first decoder.

10. The dynamically configurable ultrasound transducer of claim 8, wherein the first decoder comprises either a row decoder or a column decoder.

11. A dynamically configurable ultrasound transducer comprising:

- an array of capacitive transducer elements,
- a first row decoder and column decoder pair coupled to said array of capacitive transducer elements,

a second row decoder and column decoder pair coupled to said array of capacitive transducer elements,
a DC bias voltage source coupled to said first row decoder and column decoder pair, and
an AC driving signal source coupled to said second row decoder and column decoder pair.

12. The dynamically configurable ultrasound transducer of claim 11 further comprising a master clock coupled to said first row decoder and column decoder pair and to said second row decoder and column decoder pair.

* * * * *

专利名称(译)	可动态配置的超声换能器，带有积分偏置调节和指令与控制电路		
公开(公告)号	US20050054933A1	公开(公告)日	2005-03-10
申请号	US10/971457	申请日	2004-10-21
申请(专利权)人(译)	SCIMED LIFE SYSTEMS INC.		
当前申请(专利权)人(译)	BOSTON SCIENTIFIC SCIMED, INC.		
[标]发明人	MAMAYEK DONALD S		
发明人	MAMAYEK, DONALD S.		
IPC分类号	B06B1/02 G10K11/34 A61B8/14		
CPC分类号	G10K11/341 B06B1/0292		
其他公开文献	US7544165		
外部链接	Espacenet	USPTO	

摘要(译)

可动态配置的超声换能器元件和相关电路和方法。换能器可包括电容换能器元件阵列，耦合到所述电容换能器元件阵列的行解码器，耦合到所述电容换能器元件阵列的列解码器，耦合到所述行解码器的偏置电压源，以及驱动信号源耦合到所述列解码器。优选地，还提供主时钟以允许行解码器和列解码器之间的信号同步。

