



(19) **United States**

(12) **Patent Application Publication**  
**Cerofolini**

(10) **Pub. No.: US 2003/0036704 A1**

(43) **Pub. Date: Feb. 20, 2003**

(54) **METHOD AND APPARATUS FOR TRANSMITTING ULTRASOUND PULSES AND RECEIVING ECHO SIGNALS AT A HARMONIC OF THE TRANSMISSION FREQUENCY**

(52) **U.S. Cl. .... 600/437**

(76) **Inventor: Marino Cerofolini, Subbiano (IT)**

(57) **ABSTRACT**

Correspondence Address:  
**Woodard, Emhardt, Naughton,  
Moriarty and McNett  
Bank One Center/Tower  
111 Monument Circle, Suite 3700  
Indianapolis, IN 46204-5137 (US)**

A method for transmitting ultrasound pulses and receiving echo signals at a harmonic of the transmission frequency includes the steps of generating a signal for exciting a transducer to transmit at least one ultrasound pulse at a basic transmission frequency and receiving the reflection echo of said pulse at a harmonic of the frequency of the transmitted pulse, any contributions to the harmonic frequency being removed or attenuated in the signal for exciting pulse transmission, characterized in that the signal for exciting the transducer/s is filtered or coupled thereto via a resonant circuit which is calibrated to the basic frequency. In combination therewith or alternatively thereto, the method includes a resonant circuit for additional coupling with a receiver. Included is an apparatus for transmitting ultrasound pulses and receiving echo signals at a harmonic of the transmission frequency, particularly an ultrasound imaging probe and an ultrasound imaging machine.

(21) **Appl. No.: 10/217,779**

(22) **Filed: Aug. 13, 2002**

(30) **Foreign Application Priority Data**

Aug. 14, 2001 (IT) ..... SV2001A00030

**Publication Classification**

(51) **Int. Cl.<sup>7</sup> ..... A61B 8/00**

**RX**

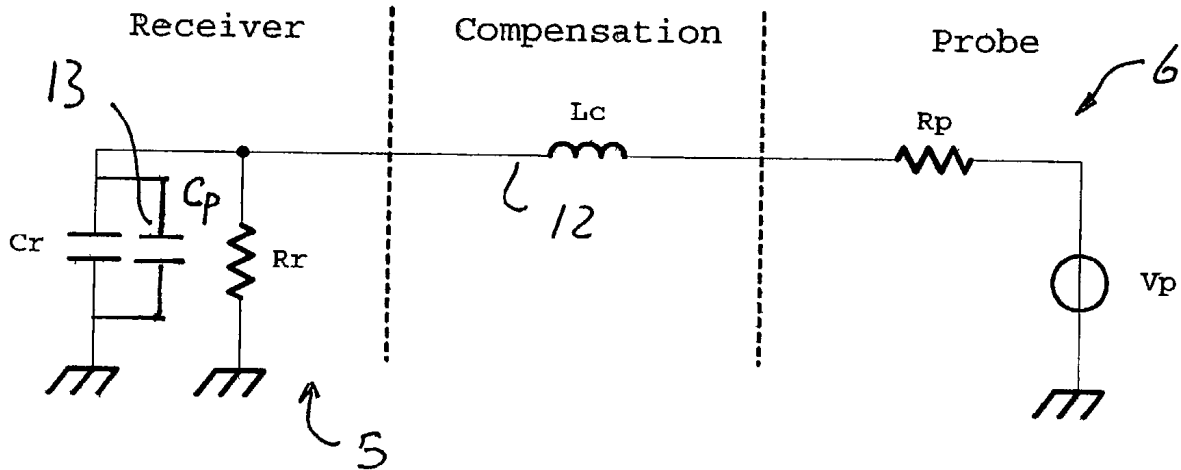

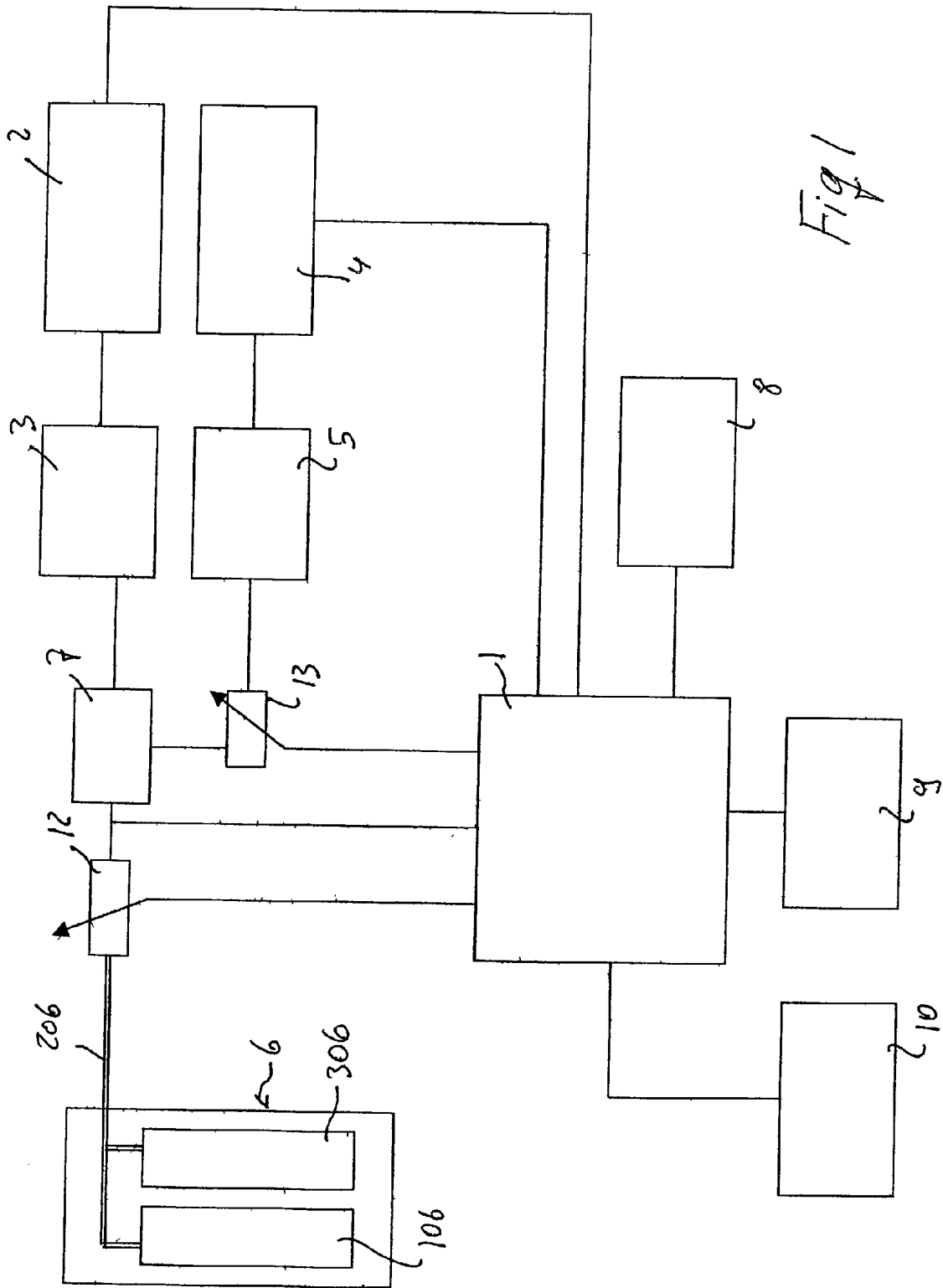
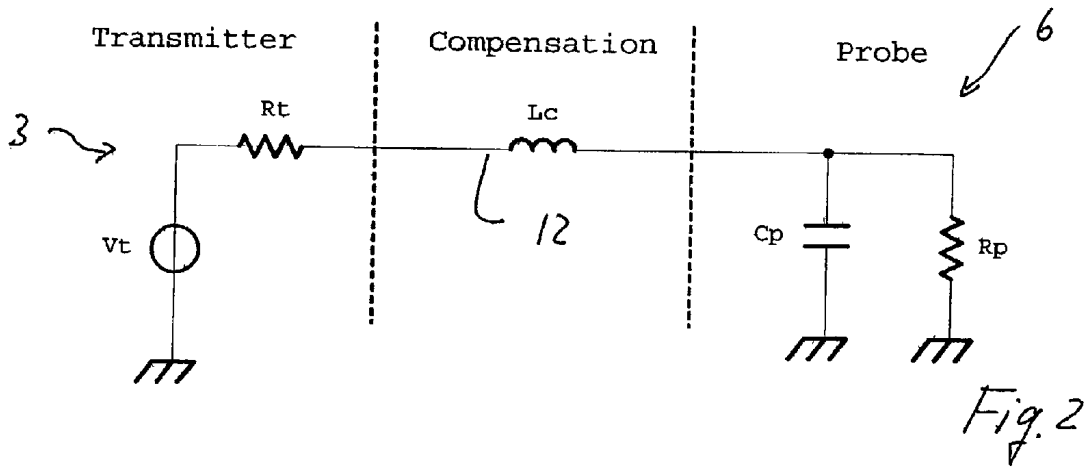
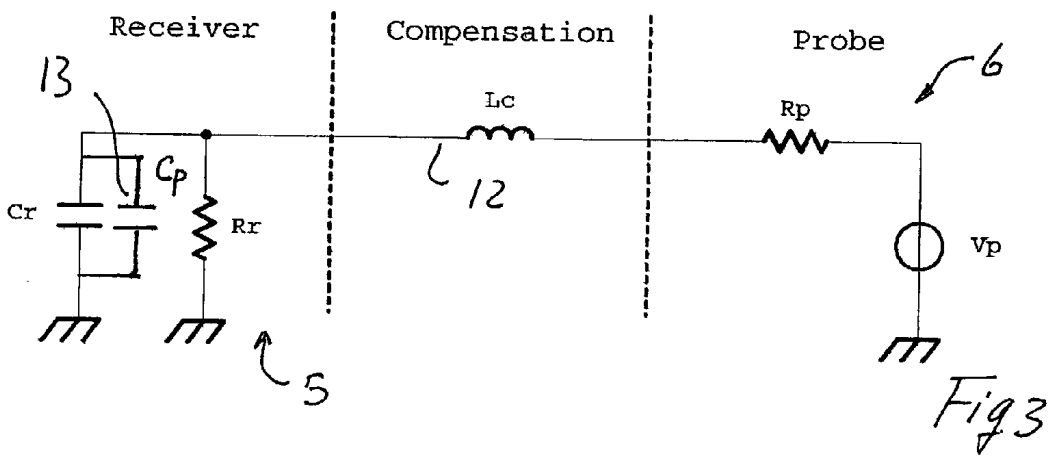

Fig 1

### TX



### RX



**METHOD AND APPARATUS FOR TRANSMITTING  
ULTRASOUND PULSES AND RECEIVING ECHO  
SIGNALS AT A HARMONIC OF THE  
TRANSMISSION FREQUENCY**

**REFERENCE TO RELATED APPLICATION**

[0001] The present patent application claims foreign priority benefits under 35 U.S.C. §119 to Italian patent application No. SV2001A000030, filed Aug. 14, 2001, now pending.

**BACKGROUND OF THE INVENTION**

[0002] The present invention relates generally to a method for transmitting ultrasound pulses and receiving echo signals at a harmonic of the transmission frequency including the steps of generating a signal for exciting a transducer to transmit at least one ultrasound pulse at a basic transmission frequency and the steps of receiving the reflection echo of said pulse at a harmonic of the frequency of the transmitted pulse, any contributions to the harmonic frequency being removed or attenuated in the signal for exciting pulse transmission. Included as part of the present invention is an apparatus for practicing the described method.

[0003] In ultrasound imaging machines operating in the harmonic imaging mode, signal generators are provided for exciting an array of transducers to transmit ultrasonic pulses at a certain frequency. The ultrasonic pulses transmitted at a certain basic frequency toward a body under examination are backscattered and the transducers are used as sensors for receiving the reflected echo signals at a harmonic of the basic frequency of the transmitted pulses, typically at the second harmonic frequency, the electric signals generated by said transducers being provided to a receiver.

[0004] This ultrasound imaging mode is very useful when contrast agents are used for valid diagnostic imaging of spontaneous flows of body fluids, such as blood flows or the like, which are poorly echogenic. Unlike substantially stationary tissues, which have an echogenic behavior, contrast agents have a nonlinear reflection behavior, hence the back-scattered echo signals have harmonic frequencies, especially corresponding to the second harmonic of the basic frequency of the transmitted pulses. Therefore, the reflection contributions provided by fluid flows in which contrast agents are injected may be distinctly separated, with no risk for the latter to be dazzled by the reflection signals of stationary tissues, which have definitely higher intensities.

[0005] Nevertheless, transmitted pulses are currently not completely pure, but include harmonic components. This is partly due to the specific characteristics of the generator-transducer assembly, and partly to the fact that, even when pure sinusoidal waves are provided, pulse formation, i.e. the time cut of the waveform or time limit thereof, necessarily causes the generation of such spectra as to include harmonic frequencies. The presence of components whose frequencies correspond to at least one harmonic, and particularly to the second harmonic of the basic frequency in the transmitted pulses causes the echo signals to be distorted by said components. Therefore, there is the need to remove or drastically attenuate all components having harmonic frequencies in the transmitted signals.

[0006] It is known from U.S. Pat. No. 5,833,614 (issued Nov. 10, 1998 to Dodd et al.) to superpose the transmission

signal provided by the generator to the transducer with an additional signal or pulse for attenuating or removing the harmonic components, for instance a pulse with the same profile as a Gaussian curve having the maximum at the basic frequency. This signal must be specially generated and superposed in a synchronized manner.

[0007] Nevertheless, this is a highly complex system which requires linear pulsers, therefore it is expensive and has a low electrical performance, which makes it incompatible with small and/or low-cost apparatuses.

[0008] Therefore, the present invention has the object of providing a method and an apparatus as described hereinbefore which, by simple and inexpensive arrangements, allow to remove any harmonic components in the transmitted pulses without using linear pulsers and to remove spurious harmonic components introduced upon reception of echo signals in a manner that is substantially independent from the type of probe in use and anyway not requiring complex and difficult adaptation methods.

[0009] The present invention achieves the above purposes by providing a method as described herein, in which the signal for exciting the transducer/s is filtered or coupled thereto through a resonant circuit calibrated to the basic frequency.

[0010] Particularly, a resonant circuit for coupling to the generator is generated, which upon transmission, resounds at the basic frequency of the transmitted pulses.

[0011] Alternatively thereto or in combination therewith the present invention provides that the transducer/s are filtered or coupled to the receiver through a resonant circuit which is calibrated to the receive harmonic frequency, particularly to the second harmonic of the basic frequency of the transmitted pulse.

[0012] A resonant circuit is actually provided which, upon reception, resounds at the predetermined harmonic frequency, particularly at the second harmonic frequency.

[0013] According to an improvement, the method of the present invention provides the use, as a transmitting resonant circuit, of the assembly composed of the transducer/s and the cable connecting it to a transmitter which generates electric pulses for exciting the transducer/s, the resonance frequency being adjusted to the basic frequency by inserting an inductance in series between the connecting cable and the transmitter.

[0014] Since the inductance value for determining the resonance frequency is determined by specific electric characteristics of the probe assembly, composed of the transducers and the connecting cable, the inductance may be appropriately selected for each type of probe and be mounted in advance on the cable or the probe itself.

[0015] The above is based on the acknowledgement that the cable-probe assembly actually is a resonant circuit having measurable capacitance and resistance values. Therefore, for each probe-cable combination, it is possible to determine the inductance value required to calibrate the resonant circuit to the basic frequency. The behavior of the resonant circuit is independent from the generator or transmitter, as the transmitter actually is a low-impedance generator.

[0016] According to a further improvement, regarding the receiving resonant circuit, the latter consists of the receiver itself which, upon reception, operates like a resonant circuit having predetermined resistance and capacitance values, whereas the cable-transducer or transducers/cable assembly behaves like a low to medium impedance generator.

[0017] As provided for transmission tuning, a tuning inductance is also provided upon reception.

[0018] Here, the analysis of typical resistance and parasitic capacitance values of receivers surprisingly showed that the same tuning inductance used to calibrate the transmitting resonant circuit may be used for the receiving resonant circuit.

[0019] In fact, the parasitic capacitance was generally found to be sufficient to cause the receiving resonant circuit to be properly tuned to the second harmonic frequency in combination with the inductance for tuning the transmitting resonant circuit.

[0020] However, if the parasitic capacitance of the receiver combined with the tuning inductance value provided for the transmit circuit is not suitable for tuning the receiving resonant circuit to the frequency of the selected harmonic, particularly of the second harmonic, a compensating capacitor may be provided, parallel to the parasitic capacitance of the receiver.

[0021] In this case, the sum of the parasitic capacitance of the receiver and of the compensating capacitance is selected as a quarter of the total capacitance of the probe-cable, or transducer/s-cable assembly, and the compensating capacitor does not affect the behavior of the transmitting resonant circuit.

[0022] Regarding the need to have a resonant circuit in the receiving chain, it shall be noted that, although the provision of this resonant circuit is certainly desirable, the latter is not so critical as for the transmitting resonant circuit. In fact, the transmitted pulses are already intrinsically free or substantially free of harmonic components, hence the generation of artifacts due to said components of the transmitted pulses is already widely suppressed or attenuated. Nevertheless, the presence of a resonant circuit properly tuned to the second harmonic is advantageous both to further limit the harmonic components due to parasitic processes and to cause, already upon reception, the basic band reflection signal to be filtered, without using or substantially limiting the procedures to extract, upon reception, the second harmonic signal from the reflected signals which obviously contain relatively high power or intensity components at the basic frequency. Although, when a compensating capacitor is provided, the latter is to be optimized based on the capacitance of the transducer/s-cable assembly and on the parasitic capacitance of the receiver, it should be understood that the generators typically have substantially similar constructions and in most cases, the parasitic capacitances are substantially identical and of the same order of magnitude. Anyway, even when the latter were not true, compensating capacitor are relatively easily adaptable, by using a variable capacitor, e.g. manually controlled for tuning and/or automatically set by the machine thanks to an automatic procedure for determining electric values through direct measurement by the ultrasound imaging machine or by plug-and-play protocols, whereby the relevant data of the probe or transducer or

transducers-cable assembly and/or the data of the receiver are stored in a special portion of the memory associated to one of the components of the probe-cable assembly and/or of the receiver.

[0023] This mode also provides the opportunity to obtain an automatic tuning system which, by reading the technical electric characteristics of the probe-cable assembly and/or of the receiver, controls either a variable inductance or a variable compensating capacitor to achieve the optimized tuning conditions as better specified above.

[0024] Alternatively to the above, the type of probe-cable assembly may be also recognized with the help of tables stored in the apparatus, which provide information on said assembly associated to a probe identification code. In this case, the probe may be selected manually, based on the name or identification code thereof, or the assembly has the identification code stored therein so that, upon connection, the apparatus reads the identification code provided by the probe, finds the corresponding table of characteristics and sets the inductance and possibly the compensating capacitor based on the characteristics defined in the table.

[0025] A system might be also provided, whose operation is identical to loading of drivers for computer peripheral devices. In this case, a readable storage medium is provided with the probe, such as a floppy disk, a CD-Rom, a batchcard or the like, the apparatus including a reader of the storage medium. A special system including a dedicated microprocessor or the processing unit itself of the ultrasound imaging machine and at least one memory or memory area dedicated to the storage of tables of characteristics, transfers data from the reader to said memory or memory area by using it according to a set-up program for automatically setting inductance and possibly compensating capacitor to the proper values for the probe-cable assembly. The procedure is substantially the same as is used to load peripheral drivers in computers.

[0026] Obviously, besides the above, other automatic or semiautomatic modes may be provided to recognize the probe-cable assembly and to set tuning inductances and compensating capacitors.

[0027] In accordance with a further improvement, the present invention provides the combination of a frequency filtering process upon transmission and/or reception of ultrasonic transmitted pulses and reflection echoes respectively, by using a multiple pulse imaging technique, which provides that image data is obtained by combining the reflected echoes of at least two successive identical transmitted pulses focused along the same line of view. These combinations may be a difference between the reflection echoes provided by two identical transmitted pulses or a sum of two successive transmitted pulses, which are inverted, i.e. 180° dephased, like in the Pulse Inversion technique.

[0028] The above mentioned combination arranges the transducer/s, or the probe to be coupled, through a resonant circuit, to the transmitter and/or the receiver, and at least two successive identical or inverted transmitted pulses, in which reflection echoes are subtracted or added respectively, image data being obtained from said difference or sum signal.

[0029] The combined use of the method of the invention with the above multiple pulse modes generates a synergistic

effect which allows to obviate the drawbacks of multiple pulse modes and to improve the method of this invention.

[0030] In fact, the coupling through resonant circuits appropriately calibrated for transmission and reception has the advantage of providing a frequency filtering action on the reflection echoes, aimed at extracting the harmonic component and particularly the second harmonic component of echoes, thus being a very simple method of extracting the reflection signals caused, for instance, by contrast agents. Nevertheless, frequency filtering requires a distinct separation between transmission and reception which are to be performed with a relatively narrow frequency band. This may cause a low axial resolution, hence a poor discrimination of reflection echoes, caused by neighboring points on the same axis of the line of view. On the other hand, while the multiple pulse techniques meet the requirement of very narrow transmit and receive bands, they have the drawback of being affected by motion clutters on received signals.

[0031] By combining the two techniques, relatively wider transmit and/or receive passbands may be provided, thanks to multiple pulse techniques, such as Pulse Inversion or the like, thereby obtaining a better resolution and at the same time removing motion clutters thanks to a proper tuning of the resonant circuits which allow coupling with the transducer/s or the probe to the transmitter and/or the receiver.

[0032] Also, according to an improvement, since multiple pulse techniques, e.g. the Pulse Inversion technique, allow to remove the reflection signals associated to spurious components, particularly to harmonic components in transmitted pulses, it is sufficient to only connect the receiver through a resonant circuit calibrated to the desired receive frequency, e.g. to the second harmonic frequency.

[0033] An ultrasound multiple pulse imaging technique is described in EP 0770352 which was published May 2, 1997.

[0034] These multiple pulse techniques may also consist of techniques employing modulated wavelets which provide coding upon transmission and correlated filtering upon reception, wherein the term wavelets includes arbitrary analog signals not having discrete times and amplitudes as well as pulse sequences having discrete times and amplitudes, such as the technique described in U.S. Pat. No. 6,050,947 (issued Apr. 18, 2000 to Rhyne et al.) whose disclosure is expressly incorporated by reference herein.

[0035] Alternatively, multiple pulse techniques may also include a Pulse Inversion technique, in which only a few components of the at least two successive transmitted pulses are inverted, whereas the other components are not inverted, the reflected signals of the two successive pulses being summed upon reception. A technique of this type is described in U.S. Pat. No. 5,902,243 whose content is integrated herein by reference.

[0036] The invention also relates to an apparatus for transmitting ultrasound pulses and receiving echo signals at a harmonic of the transmission frequency, for example to an ultrasound imaging machine comprising:

[0037] a transmitter which generates electric signals for exciting at least one transducer to transmit ultrasound pulses at a predetermined basic frequency, a receiver whereto electric signals are provided from one or more transducers which pick up reflected echo signals at a harmonic fre-

quency, particularly a second harmonic of the frequency of the transmitted pulses and means for removing or drastically attenuating the contributions of harmonic components, particularly those at the second harmonic in transmitted pulses, said means consisting of a resonant circuit which allows to couple the transducer/s to the transmitter, whose resonance frequency is set to the basic frequency of the transmitted pulses.

[0038] Particularly, the resonant circuit consists of the assembly composed of the probe, i.e. the transducer/s thereof and the connecting cable, there being provided an inductance for tuning the resonance frequency of said resonant circuit to the basic frequency of the transmitted pulses.

[0039] Particularly, the tuning inductance is connected in series to the resistor of the assembly composed of the probe or transducer/s thereof and the output of the transmitter.

[0040] The transmitter is a low-impedance generator in accordance with an additional characteristic, which may be provided as an alternative thereto or in combination therewith, the apparatus includes a resonant circuit for coupling the receiver to the assembly composed of the probe or transducer/s thereof and the connecting cable, which is tuned to a resonance frequency corresponding to a predetermined harmonic, particularly to the second harmonic of the basic frequency of the transmitted pulses.

[0041] Advantageously, the resonant circuit consists of the receiver, i.e. of the resistor and the parasitic capacitance thereof.

[0042] When the parasitic capacitance of the receiver, besides providing the inductance for tuning the transmitting resonant circuit does not allow to tune the receiving resonant circuit to said harmonic frequency, a compensating capacitor may be provided.

[0043] The compensating capacitor is connected in parallel to the parasitic capacitance of the receiver.

[0044] Particularly, it is advantageous to provide such a compensating capacitor that the sum of the parasitic capacitance of the receiver and the compensating capacitance substantially corresponds to a quarter of the capacitance of the transmitting resonant circuit, i.e. of the assembly composed of the probe or the transducer/s thereof and the connecting cable.

[0045] The advantages of the present invention are self-evident from the above description. The specific inductance for tuning the transmitting resonant circuit may be mounted on the probe-cable assembly. Hence, each probe is adapted regardless of the apparatus, i.e. of the transmitter thereof whereto it will be coupled. The operation is performed on the probe and does not need to account for the transmitter and the characteristics thereof. As a transmitter, a sinusoidal transmitter may be used, which is highly cost-effective.

[0046] Typically, the receiving resonant circuit is tuned in a substantially automatic manner, and the specific compensating capacitor of the receiving resonant circuit may be anyway provided thereon. The value of such capacitance may be adjusted by a special control, e.g. thanks to a variable capacitor, in a simple and fast manner. Moreover, it shall be noted that, upon reception, tuning is less critical as regards reception of spurious signals, because, with high-quality transmitted pulses, as regards removal or attenuation of

harmonic frequencies, the reflected signals at harmonic frequencies will already have a lower probability of containing harmonic components not due to contrast agents but generated by parasitic effects.

[0047] With reference to a further improvement, the apparatus of the invention includes at least one transmitter and at least one transducer having a cable for connecting it to the transmitter and a memory, a control unit and a variable and adjustable inductance, which may be controlled by the control unit, the electric characteristics of the transducer-connecting cable assembly being loaded in the memory together with a software program for reading said electric characteristics and for controlling the inductance to tune the resonant circuit formed by the transducer-connecting cable assembly to the basic frequency of the transmitted pulse, which program is automatically executed upon connection of the transducer-cable assembly to the transmitter by sensors for detecting the electric conditions of the connecting interface between the transducer-cable assembly and the transmitter.

[0048] The memory may be steadily mounted in the transducer-cable assembly.

[0049] A variant embodiment provides two memories, a first memory being mounted on the transducer-cable assembly, wherein an identification code for said assembly is stored, and a second memory being associated to the transmitter and to the control unit, for storage of all data relating to the electric characteristics of several different transducer-cable assemblies, which are uniquely identified by an identification code, the identification code of each transducer-cable assembly being read upon connection of said assembly, by the control unit, and the data relating to said identification code being searched in the second memory to execute, based on said data, the program for setting the variable inductance to tune the transmitting oscillating resonant circuit.

[0050] An additional improvement provides the further combination of an external portable storage medium for storing the electric data of a predetermined transducer-cable assembly and a reader of said medium connected to the control unit, there being provided a program for causing said data to be loaded from the portable storage medium into the second memory when in said second memory no data identified by the identification code of the transducer-cable assembly is present.

[0051] In accordance with yet another improvement, the apparatus also includes a receiver and an alternative circuit for connecting the transducer-cable assembly to the transmitter and to the receiver, there being provided a variable capacitor for compensating the parasitic capacitance of the receiver to tune the receiving resonant circuit, and there being provided a software program for controlling the variable capacitor to the proper value to tune the receiving resonant circuit based on the data of the electric characteristics of the transducer-cable assembly connected to the receiver, which is executed by the control unit, in the same manner as the transmit resonant circuit is tuned.

[0052] The transducer-cable assembly includes several transducers and is particularly composed of an ultrasound imaging probe and the corresponding connecting cable.

[0053] The transmitting and/or receiving apparatus consists of the corresponding unit of an ultrasound imaging machine.

[0054] The second memories and the control unit, as well as possibly the reader of the portable storage media are memories, processors and storage media readers which are already included in the ultrasound imaging machine.

[0055] Therefore, the invention also relates to an ultrasound imaging probe comprising at least one transducer for turning electric signals into ultrasound transmit pulses, e.g. a piezoelectric transducer and a cable for connecting said probe to an ultrasound imaging apparatus, there being provided an inductance for tuning the resonant circuit formed by the capacitor and the resistor of the probe-cable assembly.

[0056] The inductance may be adjustable and controllable by a central unit outside the probe and included, for instance in an ultrasound imaging machine.

[0057] Further, the probe and/or the cable for connecting it may include a memory which contains the data relating to at least one unique identification code for said probe-connecting cable assembly and/or the data of the capacitance and resistance values of the equivalent resonant circuit formed by said probe-connecting cable assembly, the memory being readable through the connecting cable by a processing and control unit of an ultrasound imaging machine.

[0058] The invention also relates to an ultrasound imaging apparatus including at least one transmitter with a connection interface and at least one ultrasound imaging probe-connecting cable assembly, said interface having an inductance for tuning the resonant circuit formed by said probe-connecting cable assembly.

[0059] Also, the ultrasound imaging apparatus includes a processing unit for reading a memory containing all data relating to the electric resistance and capacitance characteristics of the probe-connecting cable assembly, for a predetermined type of such an assembly, to be uniquely defined by an identification code, which sets the value of a variable inductance for tuning said resonant circuit based on said data.

[0060] The ultrasound imaging machine also includes a receiver and means for alternatively connecting the probe-connecting cable assembly to the transmitter and to the receiver.

[0061] In accordance with an improvement, said ultrasound imaging apparatus includes a capacitor for compensating the parasitic capacitance of the receiver which, upon reception, forms a resonant circuit, to tune said resonant circuit to a predetermined frequency.

[0062] Advantageously, said compensating capacitor is variable and is set on the value which allows tuning to the frequency selected, in accordance with the data of the electric characteristics of the probe-cable assembly, by the processing and control unit of the machine.

[0063] The present invention further relates to an apparatus for transmitting ultrasound pulses and receiving echo signals as described herein, for instance an ultrasound imaging machine including a transmitter which generates electric signals for exciting at least one transducer to transmit

ultrasound pulses at a predetermined basic frequency, a receiver whereto electric signals are provided from one or more transducers which pick up reflected echo signals at a harmonic or sub-harmonic frequency, particularly a second harmonic of the frequency of the transmitted pulses and a resonant circuit through which the transducer/s are coupled to the receiver, whose resonance frequency is set to a harmonic or sub-harmonic frequency of the basic frequency of the transmitted pulses, particularly to a second harmonic of the frequency of the transmitted pulses, there being provided means for transmitting, for each line of view, at least two successive identical or phase-inverted transmission pulses and means for combining the received reflection echoes, caused by said two pulses in the form of a subtraction or a sum of the two reflection echoes respectively, such as a summer or subtracting circuit.

[0064] In combination with the above, a device may be provided in which the transducer/s, i.e. the probe, is also coupled to the transmitter through a resonant circuit calibrated to the fundamental frequency of the transmitted pulses.

[0065] Said transmitting and/or receiving resonant circuits may be provided as described above and in any of the above combinations and sub-combinations.

#### SUMMARY OF THE INVENTION

[0066] A method for transmitting ultrasound pulses and receiving echo signals at a harmonic of the transmission frequency according to one embodiment of the present invention includes the steps of generating a signal for exciting a transducer to transmit at least one ultrasound pulse at a basic transmission frequency, receiving the reflection echo of the pulse at a harmonic of the frequency of the transmitted pulse wherein any contributions to the harmonic frequency are removed or attenuated in the signal for exciting pulse transmission, the invention being characterized in that the signal for exciting the transducer is filtered or coupled thereto by way of a resonant circuit which is calibrated to the basic frequency. A related embodiment of the present invention comprises an apparatus for practicing the method.

[0067] One object of the present invention is to provide an improved method and apparatus for transmitting ultrasound pulses and receiving echo signals at a harmonic of the transmission frequency.

[0068] Related objects and advantages of the present invention will be apparent from the following description.

#### BRIEF DESCRIPTION OF THE DRAWINGS

[0069] FIG. 1 shows a block diagram of an ultrasound imaging machine according to a typical embodiment of the present invention.

[0070] FIG. 2 shows the equivalent diagrams of a transducer-cable assembly and transmitter associated with the FIG. 1 ultrasound imaging machine.

[0071] FIG. 3 shows the equivalent diagrams of a transducer-cable assembly and receiver associated with the FIG. 1 ultrasound imaging machine.

#### DESCRIPTION OF THE PREFERRED EMBODIMENT

[0072] For the purposes of promoting an understanding of the principles of the invention, reference will now be made

to the embodiments illustrated in the drawings and specific language will be used to describe the same. It will nevertheless be understood that no limitation of the scope of the invention is thereby intended, such alterations and further modifications in the illustrated device, and such further applications of the principles of the invention as illustrated therein being contemplated as would normally occur to one skilled in the art to which the invention relates.

[0073] Referring to FIG. 1, an ultrasound imaging apparatus includes a central unit 1 which controls a transmission channel 2 having a transmitter 3. Moreover, the central unit 1 also controls a receiving channel 4 having a receiver 5. The transmitter 3 and the receiver 5 are connected to a probe 6 by means of a switching and ultrasonic beam-forming unit 7.

[0074] Memories 8, a display screen 9 and a unit 10 for reading/writing portable storage media are further connected to the central processor unit 1.

[0075] The probe 6 includes a plurality of transducers 106 which are connected together by the cable 206. The cable 206 is also connected to the switch 7, hence to the transmitter and the receiver by means of an inductance 12, whereas the probe and the cable are connected to the receiver 5 by means of both the inductance 12 and a capacitor 13 which is inserted in the circuit in parallel with the parasitic capacitance of the receiver 5.

[0076] FIGS. 2 and 3 show an equivalent circuit upon transmission and reception respectively, i.e. when the switch 7 connects the probe 6 and the cable 206 to the transmitter 3 and the receiver 5 respectively. While the transmission and receiving channels are physically joined by a separator circuit, i.e. the switching unit 7, the equivalent circuits thereof are different. Particularly, upon transmission, the transmitter 3 operates like a low impedance generator, whereas the assembly composed of the probe 6 and the cable 206 actually forms a resonant circuit. Conversely, upon reception, the receiver 5 operates like a resonant circuit, whereas the probe-cable assembly operates like a low to medium impedance generator.

[0077] Therefore, due to the above, in order to remove or drastically attenuate the harmonic components, particularly those having a second harmonic frequency in the transmitted ultrasonic pulse and to remove or drastically attenuate the contributions to the received signal having frequencies other than those at a predetermined harmonic of the fundamental transmission frequency, e.g. at the second harmonic, the following tuning condition may be used for oscillating resonant circuits.

[0078] By inserting an inductance 12 having an appropriate value between the assembly composed of the probe 6 and the cable 206 and the transmitter 3 and the receiver 5, the corresponding oscillating circuit may be calibrated, i.e. the circuit formed by said probe-cable assembly may be calibrated to the resonance frequency corresponding to the fundamental frequency of transmission pulses, and the circuit formed by the receiver may be calibrated to the selected harmonic of the fundamental transmission frequency, particularly to the second harmonic.

[0079] For instance, when considering a basic frequency of 2 MHz, and typical resistance and capacitance values for the assembly composed of the probe 6 and the cable 206 of

$C_p=400$  pF (whereof 300 pF due to the ceramic material and 100 pF to the cable);  $R_p=400$   $\Omega$ , it is apparent that a compensating inductance  $L_c$  of 15  $\mu$ H causes the transmit circuit to resound at the frequency of 2 MHz.

[0080] When further considering typical values of parasitic capacitance and resistance for the receivers **5**, such as  $R_r=4$  k $\Omega$ ; and  $C_r=100$  pF, the resonance frequency of the circuit, in combination with said compensating inductance  $L_c$  of 15  $\mu$ H results to be 4 MHz, i.e. at the second harmonic of the fundamental frequency of the transmitted pulse.

[0081] If the parasitic capacitance  $C_r$  is not such as to allow proper tuning to the second harmonic upon reception, a compensating capacitor  $C_c$  may be placed in parallel to  $C_r$ , so that  $C_c+C_r$  are approximately equal to  $C_p/4$ . This allows to maintain the tuning inductance on an optimized value for transmission and to also tune the transmitting resonant circuit.

[0082] It is important to notice that the above concepts may be also inverted, i.e. the tuning inductance may be set on the receiver, and a compensating capacitor may be considered which, in combination with said tuning inductance, optimizes tuning of the transmitting resonant circuit.

[0083] As mentioned above, the optimized tuning inductance may be directly mounted on the probe-cable assembly, regardless of the specific ultrasound imaging machine, as the transmitting resonant circuit is tuned regardless of the characteristics of the transmitter **3**.

[0084] Here, each probe-connecting cable assembly would have its own tuning inductance which is determined based on the electric characteristics of said specific assembly.

[0085] Regarding the presence of the compensating capacitor, the latter might be set after selecting a predetermined assembly, if the tuning capacitor provided with the probe and the cable could not allow optimized tuning of the receiving resonant circuit.

[0086] Advantageously, according to a first improvement, the probe **6** might include a memory **306** for storing the relevant electric data for tuning the receiving resonant circuit, and particularly the value of the compensating inductance associated to the probe and the value of the equivalent capacitor of the probe-cable assembly. When the probe and cable are connected to the ultrasound imaging machine, the central processing unit **1** might read data from the memory **306** of the probe **6**. Based on said data, the processing unit **1** may first determine if a compensating capacitor is to be set for the receiving channel. When a compensating capacitor is needed, said processing unit may secondly determine the value of said compensating capacitor and set a variable capacitor provided in the receiving channel parallel to the parasitic capacitance of the receiver **5** to said capacitance value.

[0087] However, in accordance with another alternative characteristic, the memory **306** of the probe may only contain one identification code, whereas the memory **8** may contain several tables of data relating to several different probe-cable assemblies, as well as a software program for reading the identification code stored **306** in the probe **6** and for comparing it with the list of identification codes included in the memory **8** and uniquely associated to tables of electric

data of the assembly identified by said code whereby, once the data table whose code coincides with the one read from the memory **306** of the probe is found, the procedure of setting the compensating capacitor of the receiving resonant circuit is executed as described above.

[0088] If no table is found to correspond to the identification code provided by the probe, the comparing program directly requests data through a message, e.g. displayed on the screen **9** or transmitted by any other means, possibly sound. In this case, a portable magnetic medium may be provided in combination with the probe, with the corresponding data table stored therein, which may be read **10** by the machine by means of a special reader **10**, whereby the data may be loaded into the memory **8** and the set up procedure may be executed as described above. The above procedures may be executed in a manner similar to the installation of drivers for computer devices or the like, like plug and play procedures.

[0089] As is apparent from **FIG. 1**, the set up procedure as described above for the compensating capacitor of the resonant circuit in the receiving channel is also applicable to the resonant circuit tuning inductance in the transmission channel.

[0090] In this case, the inductance might not be placed on the probe-cable assembly, but at the input of the ultrasound imaging machine. By using a variable inductance, controlled by the central processor **10** on the basis of the electric data of the probe-cable assembly, the ultrasound imaging machine may be arranged to automatically or semiautomatically set said tuning inductance to an optimized value for the probe-cable assembly being used. It shall be noted that, here again, all the above considered options for setting the compensating capacitor to tune the resonant circuit in the receiving channel may be provided. It shall be further noted that, in the same manner as the compensating capacitor may be set to zero, i.e. excluded from the circuit, even the variable tuning inductance provided inside the ultrasound imaging machine may be reduced to zero or by-passed, if the probe already has a tuning inductance integrated thereon, as this would result from the information provided either automatically by the memory integrated in the probe or by the tables contained in the memory of the ultrasound imaging machine, or by the data contained in any portable storage media.

[0091] The above description clearly shows the advantages of the invention. First, the invention allows to remove or reduce the spurious signal components upon transmission. Moreover, the resonant circuit may be tuned directly on the probe, regardless of the ultrasound imaging machine in use. The provision of a tuning inductance also has an effect on the receiving channel, which is also similar to a resonant circuit, to be tuned in most cases to the second harmonic resonance frequency already based on the tuning inductance for the transmitting resonant circuit.

[0092] The transmitting and/or receiving resonant circuits may be tuned in several possibly automatic or semiautomatic manners. Particularly, by coupling the receiving channel to the probe through a resonant circuit which is tuned or may be tuned to the second harmonic frequency, any contribution to the received signal due to the second harmonic may be separated from those at the fundamental frequency, without using the complex filtering procedures currently required, or anyway limiting the use of said procedures.

[0093] Obviously, the method and apparatus of this invention find use in any ultrasound imaging mode, particularly in any ultrasound imaging mode using contrast agents and/or received signals at a harmonic of the fundamental frequency of the transmitted pulses.

[0094] The method according to the present invention may be combined with any other kind of ultrasound imaging method for example with a multiple pulse technique employing modulated wavelets which provide coding upon transmission and correlated filtering upon reception, wherein the term wavelets includes arbitrary analog signals not having discrete times and amplitudes as well as pulse sequences having discrete times and amplitudes.

[0095] Alternatively the method according to the invention may be combined with a so called Pulse Inversion technique, in which only a few components of the at least two successive transmitted pulses are inverted, whereas the other components are not inverted, the received signals being summed together as described in U.S. Pat. No. 5,706, 819 (issued Jan. 13, 1998 to Hwang et al.) which patent is expressly incorporated by reference herein.

[0096] A further improvement may provide the method according to the present invention in combination with a multi pulse technique, in which an even number of pulses half of which is inverted with respect of the other half number of the said pulses are transmitted and the received signals relating to all or at least part of these transmitted pulses is summed together. In this case for example for each scan line four pulses are transmitted, two of which are inverted with respect of the other two, the order of transmission of the said four pulses being of any kind, particularly the normal and inverted pulses are transmitted alternatively one to the other or the two inverted pulses are transmitted directly one after the other as the first two, the last two or the intermediate two pulses.

[0097] According to yet another variant the method according to the present invention may be combined with an imaging technique providing the emission of two successive transmission pulses and the reception of the two reflection echo signals generated by said transmission pulses and in which means are provided for differentiating the two reflected echo signals from each other.

What is claimed is:

1. A method for transmitting ultrasound pulses and receiving echo signals at a harmonic of the transmission frequency including the steps of generating a signal for exciting a transducer to transmit at least one ultrasound pulse at a basic transmission frequency and the steps of receiving the reflection echo of said pulse at a harmonic of the frequency of the transmitted pulse, any contributions to the harmonic frequency being removed or attenuated in the signal for exciting pulse transmission, characterized in that the signal for exciting the transducer/s is filtered or coupled thereto via a resonant circuit which is calibrated to the basic frequency.

2. A method as claimed in claim 1, characterized in that, alternatively thereto or in combination therewith the invention provides that the transducer/s are filtered or coupled to a receiver through a resonant circuit which is calibrated to the receive harmonic frequency, particularly to the second harmonic of the basic frequency of the transmitted pulse.

3. A method as claimed in claim 1 or 2, characterized in that the assembly composed of the transducer/s and the cable

connecting it to a transmitter which generates electric pulses for exciting the transducer/s is used as a transmitting resonant circuit, the resonance frequency being adjusted to the basic frequency by inserting an inductance in series between the connecting cable and the transmitter.

4. A method as claimed in one or more of the preceding claims, characterized in that the receiving resonant circuit consists of the receiver itself which, upon reception, operates like a resonant circuit having predetermined resistance and capacitance values.

5. A method as claimed in one or more of the preceding claims, characterized in that a tuning inductance is provided for tuning the receiving resonant circuit.

6. A method as claimed in one or more of the preceding claims, characterized in that the receiving resonant circuit tuning inductance is set in such a manner that the resonance frequency is a harmonic, particularly the second harmonic of the transmission frequency.

7. A method as claimed in one or more of the preceding claims, characterized in that the receiving resonant circuit tuning inductance is set in such a manner that the resonance frequency is the same tuning inductance as provided for the transmitting resonant circuit and has the same value.

8. A method as claimed in claim 7, characterized in that a compensating capacitor is provided, which may be connected in parallel with the parasitic capacitance of the receiver to tune the receiving resonant circuit in combination with a tuning inductance in common with the transmitting resonant circuit or having the same value as the latter.

9. A method as claimed in one or more of the preceding claims, characterized in that the compensating capacitance substantially corresponds to a quarter of the capacitance of the assembly composed of the transducer/s and the connecting cable.

10. A method as claimed in one or more of the preceding claims, characterized in that it provides a variable capacitor, controlled by a control unit and means for reading relevant electric data of the assembly composed of the transducer/s and the connecting cable.

11. A method as claimed in one or more of the preceding claims, characterized in that a variable tuning inductance is provided, controlled by a control unit and means for reading relevant electric data of the assembly composed of the transducer/s and the connecting cable.

12. A method as claimed in claim 10, characterized in that it provides that a memory is associated to the assembly composed of the transducer/s and the connecting cable, which memory contains the relevant electric data for the resonant circuit formed by said assembly and may be read by the control unit to set said variable capacitor to the proper capacitance value with reference to the data of the assembly composed of the transducer/s and the connecting cable.

13. A method as claimed in claims 10 to 12, characterized in that it provides that a memory is associated to the assembly composed of the transducer/s and the connecting cable, which memory contains the relevant electric data for the resonant circuit formed by said assembly and may be read by the control unit to set said variable inductance to the proper inductance value with reference to the data of the assembly composed of the transducer/s and the connecting cable.

14. A method as claimed in one or more of claims 10 to 13, characterized in that it provides a memory associated to the unit for controlling the variable capacitor and/or the

variable inductance, said memory containing the data of several different transducer/s-connecting cable assemblies, and each of said assemblies being uniquely identified by an identification code, whereas said code may be manually set or read by the control unit from a memory associated to each transducer/s-connecting cable assembly.

**15.** A method as claimed in one or more of claims 10 to 14, characterized in that a memory is associated to the control unit for setting up the variable capacitor and/or the variable tuning inductance, in which memory a software program is loaded which detects the presence of a data table with the reference code of a specific transducer/s-cable assembly, as well as a program which automatically requests said data either by manual setting or by automatic reading of a portable storage medium when no data relating to the transducer/s-cable assembly is detected.

**16.** A method as claimed in one or more of the preceding claims, characterized in that the tuning inductance is associated to the transducer/s-cable assembly and/or to the transmitter and to the receiver, and that in the latter case it is of the variable type.

**17.** A method as claimed in one or more of the preceding claims, characterized in that the transducer/s-cable assembly consists of an ultrasound imaging probe with the corresponding connecting cable.

**18.** A method as claimed in one or more of the preceding claims, characterized in that the transmitter and the receiver are parts of the transmission and reception chain of an ultrasound imaging machine.

**19.** A method for transmitting ultrasound pulses and receiving echo signals at a harmonic of the transmission frequency including the steps of generating a signal for exciting a transducer to transmit at least two successive ultrasound pulses at a basic transmission frequency, which at least two successive pulses are identical or one of the at least two pulses is inverted relative to the other or is 180° dephased, and which at least two transmitted pulses are focused along the same scan line, and the steps of receiving the reflection echoes of said at least two successive transmitted pulses to extract the echo component at a harmonic or sub-harmonic of the frequency of the transmitted pulses, particularly a second harmonic of the fundamental frequency of the transmitted pulses, characterized in that the frequency of the received echoes is filtered by means of a resonant circuit which allows the transducer to be coupled to a receiver, which resonant circuit is tuned to the selected harmonic or sub-harmonic frequency, particularly to the second harmonic of the fundamental frequency of the transmitted pulses.

**20.** A method as claimed in claim 19, characterized in that any contributions to the harmonic or sub-harmonic frequency is removed or attenuated in the signals for exciting pulse transmission, by coupling the transducers with a resonant circuit which is calibrated to the basic frequency.

**21.** A method as claimed in claim 19 or 20, characterized in that it has the characteristics as claimed in one or more of the preceding claims 1 to 18.

**22.** A method as claimed in one or more of claims 1 to 21, characterized in that it provides the combination with a Pulse Inversion imaging technique or the like, in which image reconstruction data is obtained by the difference or the sum of the reflection echoes of at least two successive

transmitted pulses focused along the same line of view, which are identical or inverted or 180° dephased relative to each other.

**23.** An apparatus for transmitting ultrasound pulses and receiving echo signals at a harmonic of the transmission frequency, for example to an ultrasound imaging machine comprising:

a transmitter (3) which generates electric signals for exciting at least one transducer to transmit ultrasound pulses at a predetermined basic frequency, a receiver (5) where to electric signals are provided from one or more transducers which pick up reflected echo signals at a harmonic frequency, particularly a second harmonic of the frequency of the transmitted pulses and means (6, 206, 5, 12, 13) for removing or drastically attenuating the contributions of harmonic components, particularly those at the second harmonic in transmitted pulses, said means consisting of a resonant circuit (6, 206) which allows to couple the transducer/s to the transmitter (6, 106), whose resonance frequency is set to the basic frequency of the transmitted pulses.

**24.** An apparatus as claimed in claim 13, characterized in that the resonant circuit consists of the assembly composed of the transducer/s (6, 106) and the connecting cable (206), there being provided an inductance (12) for tuning the resonance frequency of said resonant circuit to the basic frequency of the transmitted pulses.

**25.** An apparatus as claimed in claim 24, characterized in that the tuning inductance (13) is connected in series to the resistor of the assembly composed of the transducer/s (6, 106) and the output of the transmitter (3).

**26.** An apparatus as claimed in claim 24 or 25, characterized in that the transmitter (3) is a low impedance generator.

**27.** An apparatus for transmitting ultrasound pulses and receiving echo signals at a harmonic of the transmission frequency, for example to an ultrasound imaging machine comprising:

a transmitter which generates electric signals for exciting at least one transducer to transmit ultrasound pulses at a predetermined basic frequency, a receiver where to electric signals are provided from one or more transducers which pick up reflected echo signals at a harmonic frequency, particularly a second harmonic of the frequency of the transmitted pulses and means for removing or drastically attenuating the contributions of components which do not correspond to a specific harmonic, particularly to the second harmonic of the frequency of transmitted pulses, said means consisting of a resonant circuit which allows to couple the transducer/s (6, 106) to the receiver (5), whose resonance frequency is set to a predetermined harmonic frequency, particularly to the second harmonic of the fundamental frequency of the transmitted pulses.

**28.** An apparatus as claimed in claim 27, characterized in that the resonant circuit consists of the receiver (5), i.e. of the resistor and the parasitic capacitance thereof.

**29.** An apparatus as claimed in claim 27 or 28, characterized in that it includes the characteristics as claimed in one or more of the preceding claims 23 to 26.

**30.** An apparatus as claimed in one or more of claims 23 to 29, characterized in that the assembly composed of the transducer/s (6, 106) and the connecting cable (206) is

alternatively connected to the transmitter (3) and to the receiver (5) through switching means (7).

31. An apparatus as claimed in one or more of the preceding claims 23 to 30, characterized in that the tuning inductance (12) for the transmitting resonant circuit and for the receiving resonant circuit have identical values.

32. An apparatus as claimed in claim 31, characterized in that a common tuning inductance (12) is provided for the transmitting resonant circuit and for the receiving resonant circuit.

33. An apparatus as claimed in one or more of the preceding claims, characterized in that, in combination with the tuning inductance (12), a compensating capacitor is associated to the receiving resonant circuit, to allow tuning to the proper resonance frequency.

34. An apparatus as claimed in claim 33, characterized in that the compensating capacitor (13) is connected in parallel with the parasitic capacitance of the receiver (5).

35. An apparatus as claimed in claim 33 or 34, characterized in that the compensating capacitor is selected in such a manner that the sum of the parasitic capacitance and the compensating capacitance corresponds to a quarter of the capacitance of the transmitting resonant circuit, i.e. of the capacitance of the assembly composed of the transducer/s (6, 106) and the connecting cable (206).

36. An apparatus as claimed in one or more of the preceding claims 33 to 35, characterized in that the compensating capacitor is a variable capacitor.

37. An apparatus as claimed in one or more of the preceding claims 23 to 36, characterized in that it includes means for automatically setting up the variable compensating capacitor (13); there being provided a control unit (1) and a memory (306, 8) associated to the assembly composed of the transducer/s (6, 106) and the connecting cable (206), which memory contains the data relating to the electric characteristics of the resonant circuit formed by said assembly and of the tuning inductance (12), said memory (306, 8) being read by the control unit, and said control unit including a software program for determining the value of the compensating capacitor (13) and for setting the variable compensating capacitor (13) to said value.

38. An apparatus as claimed in one or more of the preceding claims, characterized in that the memory (306) is associated to the assembly composed of the transducer/s (6, 106) and the connecting cable (206).

39. An apparatus as claimed in one or more of the preceding claims, characterized in that the memory (8) is associated to the receiver (5) and/or to the control unit (1).

40. An apparatus as claimed in one or more of the preceding claims 37 to 39, characterized in that the memory (306) associated to the assembly composed of the transducer/s (6, 106) and the connecting cable (206) contains one code for uniquely identifying said assembly, whereas the memory (8) associated to the receiver (5) and/or to the control unit (1) contains a plurality of data tables, each relating to a specific assembly composed of the transducer/s (6, 106) and the connecting cable (206) and each related to the unique identification code of said specific assembly, there being provided a software program for reading the code stored in the memory (306) of the assembly composed of the transducer/s (6, 106) and the connecting cable (206) and for searching a data table identified by said code in the memory (8) associated to the receiver (5) and/or to the

control unit, and a program for reading said table and for setting up the compensating capacitor (13) based on the data contained therein.

41. An apparatus as claimed in one or more of the preceding claims 37 to 40, characterized in that means (10) for reading a portable storage medium are associated to the control unit (1), whereas a portable storage medium is associated to the assembly composed of the transducer/s (6, 106) and the connecting cable (206), which storage medium contains the data relating to said assembly, the memory (8) associated to the control unit (1) containing a program which prompts to insert said portable storage medium in the reader (10) when no data table corresponding to the identification code of the assembly composed of the transducer/s (6, 106) and the connecting cable (206) has been found, and which reads data from said portable storage medium, transfers it into the memory (8) and executes the program for determining and setting the capacitance of the variable capacitor (13).

42. An apparatus as claimed in one or more of the preceding claims 37 to 41, characterized in that it has sensors for connecting the assembly composed of the transducer/s (6, 106) and the connecting cable (206) to a connection port, said sensors being connected to the control unit (1) which automatically executes the programs for reading the memories (306, 8) or the portable storage medium and the programs for determining and setting the capacitance of the compensating capacitor (13).

43. An apparatus as claimed in one or more of the preceding claims, characterized in that the tuning inductance (12) for the transmitting resonant circuit is permanently associated to the assembly composed of the transducer/s (6, 106) and the connecting cable (206).

44. An apparatus as claimed in one or more of the preceding claims 37 to 42, characterized in that the tuning inductance (12) is permanently associated to the transmitter (3) and is a variable inductance, and that it can be set to certain values by the control unit (1) which executes programs for reading the electric data of the assembly composed of the transducer/s (6, 106) and the connecting cable (206), which data is stored in a memory (306) integrated in said assembly and/or in the memory (8) and/or on portable storage media, which programs are like the programs for setting the capacitance of the variable compensating capacitor (13) as claimed in claims 37 to 42 and are loaded in the memory (8) associated to said control unit (1).

45. An apparatus as claimed in one or more of the preceding claims 23 to 43, characterized in that the assembly composed of the transducer/s (6, 106) and the connecting cable (206) consists of an ultrasound imaging probe.

46. An apparatus as claimed in one or more of the preceding claims, characterized in that the transmitter (3), the receiver (5), the switch (7), the compensating capacitor (13) and/or the variable inductance (12), the control unit (1), the memory (8) and possibly the unit (10) for reading portable storage media are parts of an ultrasound imaging machine.

47. An apparatus for transmitting ultrasound pulses and receiving echo signals as claimed herein, for instance an ultrasound imaging machine including a transmitter which generates electric signals for exciting at least one transducer to transmit ultrasound pulses at a predetermined basic frequency, a receiver where to electric signals are provided from one or more transducers which pick up reflected echo signals

at a harmonic or sub-harmonic frequency, particularly a second harmonic of the frequency of the transmitted pulses and a resonant circuit through which the transducer/s are coupled to the receiver, whose resonance frequency is set to a harmonic or sub-harmonic frequency of the basic frequency of the transmitted pulses, particularly to a second harmonic of the frequency of the transmitted pulses, there being provided means for transmitting, for each line of view, at least two successive identical or phase-inverted transmission pulses and means for combining the received reflection echoes, caused by said two pulses in the form of a subtraction or a sum of the two reflection echoes respectively, such as a summer or subtracting circuit.

**48.** An apparatus as claimed in claim 47, characterized in that the transducer/s, i.e. the probe is also coupled to the transmitter through a resonant circuit calibrated to the fundamental frequency of the transmitted pulses.

**49.** An apparatus as claimed in claim 47 or **48**, characterized in that it has the characteristics as claimed in one or more of the preceding claims 23 to 46.

**50.** An ultrasound imaging probe comprising at least one transducer or a plurality of transducers (**106**) and a cable (**206**) for connection to a port of an ultrasound imaging machine, characterized in that it integrates an inductance for tuning the equivalent resonant circuit formed by said probe (**6**).

**51.** An ultrasound imaging probe comprising at least one transducer or a plurality of transducers (**106**) and a cable (**206**) for connection to a port of an ultrasound imaging machine, characterized in that it integrates a memory (**306**) which may be accessed through the connecting cable (**206**) and stores all data relating to the electric characteristics of the equivalent resonant circuit and/or an unique identification code.

**52.** An ultrasound imaging probe as claimed in claim 51, characterized in that it has the characteristics as claimed in claim 51, with the memory (**306**) containing the data relating to the tuning inductance.

**53.** An ultrasound imaging machine characterized in that it is provided in combination with an ultrasound imaging

probe (**6**) and that the probe (**6**) and the machine include the characteristics as claimed in one or more of claims 23 to 52.

**54.** A method as claimed in one or more of the preceding claims 1 to 22, characterized in that it is provided in combination with a multiple pulse technique employing modulated wavelets which provide coding upon transmission and correlated filtering upon reception, wherein the term wavelets includes arbitrary analog signals not having discrete times and amplitudes as well as pulse sequences having discrete times and amplitudes

**55.** A method as claimed in one or more of the preceding claims 1 to 22 or **54**, characterized in that it is combined with a Pulse Inversion technique, in which only a few components of the at least two successive transmitted pulses are inverted, whereas the other components are not inverted, the received signals being summed together.

**57.** A method according to one or more of the preceding claims 1 to 22 or **54**, Or **55**, characterized in that it is combined with a multi pulse technique, in which an even number of pulses half of which is inverted with respect of the other half number of the said pulses are transmitted and the received signals relating to all or at least part of these transmitted pulses is summed together.

**58.** A method according to claim 57, characterized in that four pulses are transmitted two of which are inverted with respect of the other two, the order of transmission of the said four pulses being of any kind, particularly the normal and inverted pulses are transmitted alternatively one to the other or the two inverted pulses are transmitted directly one after the other as the first two, the last two or the intermediate two pulses.

**59.** A method as claimed in one or more of the preceding claims 1 to 22 or **54** to **58**, characterized in that it is combined with the emission of two successive transmission pulses and with the reception of the two reflection echo signals generated by said transmission pulses and with means for differentiating the two reflection echo signals from each other.

\* \* \* \* \*

专利名称(译)	用于以传输频率的谐波发送超声脉冲和接收回波信号的方法和装置		
公开(公告)号	<a href="#">US20030036704A1</a>	公开(公告)日	2003-02-20
申请号	US10/217779	申请日	2002-08-13
[标]申请(专利权)人(译)	CEROFOLINI MARINO		
申请(专利权)人(译)	CEROFOLINI MARINO		
当前申请(专利权)人(译)	CEROFOLINI MARINO		
[标]发明人	CEROFOLINI MARINO		
发明人	CEROFOLINI, MARINO		
IPC分类号	G01S7/52 G01S15/89 A61B8/00		
CPC分类号	G01S7/52038 G01S7/5205 G01S7/52077 G01S7/5208 G01S15/895		
优先权	102001900951139 2001-08-14 IT		
其他公开文献	US7458935		
外部链接	<a href="#">Espacenet</a> <a href="#">USPTO</a>		

摘要(译)

一种用于以传输频率的谐波发送超声脉冲和接收回波信号的方法包括以下步骤：产生用于激励换能器的信号，以在基本传输频率下发送至少一个超声脉冲，并在a处接收所述脉冲的反射回波。发射脉冲频率的谐波，对用于激励脉冲传输的信号中的谐波频率的任何贡献被去除或衰减，其特征在于，用于激励换能器的信号经过校准的谐振电路被滤波或耦合到其上。到基本频率。与其组合或替代地，该方法包括用于与接收器进行额外耦合的谐振电路。包括用于发送超声脉冲和以传输频率的谐波接收回波信号的设备，尤其是超声成像探头和超声成像机。

