



US 20050187470A1

(19) **United States**

(12) **Patent Application Publication** (10) **Pub. No.: US 2005/0187470 A1**

**Kubota et al.**

(43) **Pub. Date: Aug. 25, 2005**

(54) **ULTRASONOGRAPH, METHOD FOR DISPLAYING INFORMATION ON DISTORTION OF BIOLOGICAL TISSUE IN ULTRASONIC IMAGE**

**Publication Classification**

(51) **Int. Cl.<sup>7</sup> ..... A61B 8/00**

(52) **U.S. Cl. .... 600/437**

(76) **Inventors: Jun Kubota, Chiba (JP); Hiroataka Baba, Chiba (JP)**

(57) **ABSTRACT**

An ultrasonograph comprising a probe for measurement by bringing the probe into contact with a subject in a first state, first image creating means for creating a first image of the subject from the information sent from the probe, image display means for displaying the first image created by the first image creating means, means for setting at least one piece of reference information on the first image displayed by the image displaying means, second image creating means for creating a second image of the subject from the measurement information collected by bringing the probe into contact with the subject in a second state different from the first state, means for collecting information on the distortion of a desired region of interest in the second image on the basis of the variation, in the second image, of the reference information set on the first image by the setting means, and display control means for controlling the display of the distortion information collected by the distortion collecting means on the image display means.

Correspondence Address:  
**ANTONELLI, TERRY, STOUT & KRAUS, LLP**  
**1300 NORTH SEVENTEENTH STREET**  
**SUITE 1800**  
**ARLINGTON, VA 22209-3873 (US)**

(21) **Appl. No.: 10/516,598**

(22) **PCT Filed: Jun. 4, 2003**

(86) **PCT No.: PCT/JP03/07080**

(30) **Foreign Application Priority Data**

Jun. 4, 2002 (JP) ..... 2002-162288

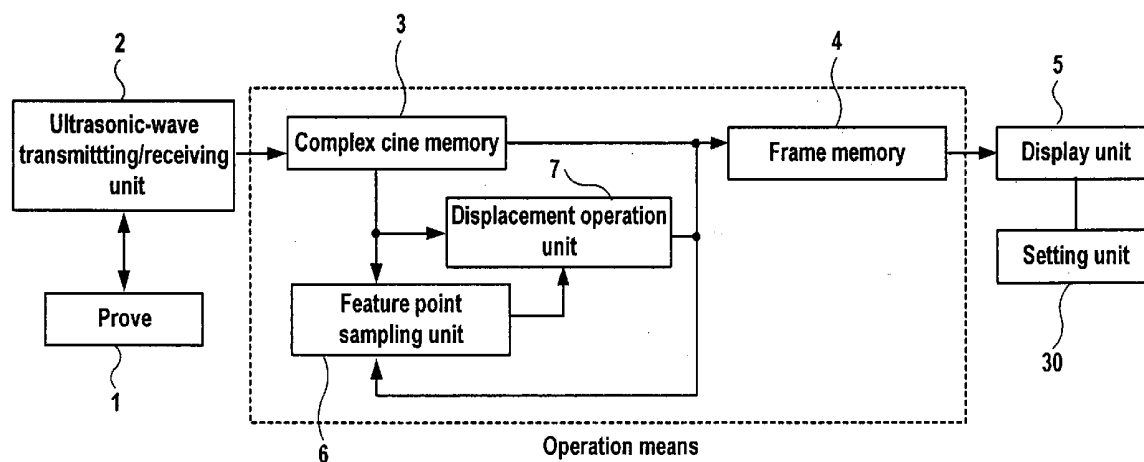

FIG. 1

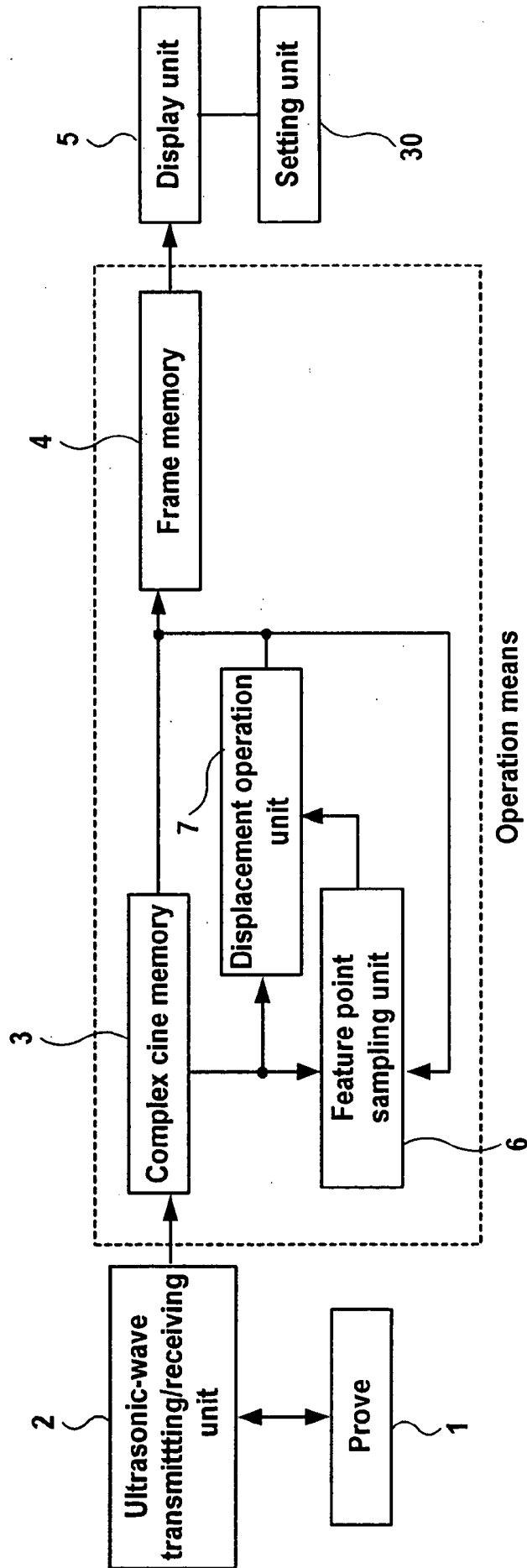

FIG. 2

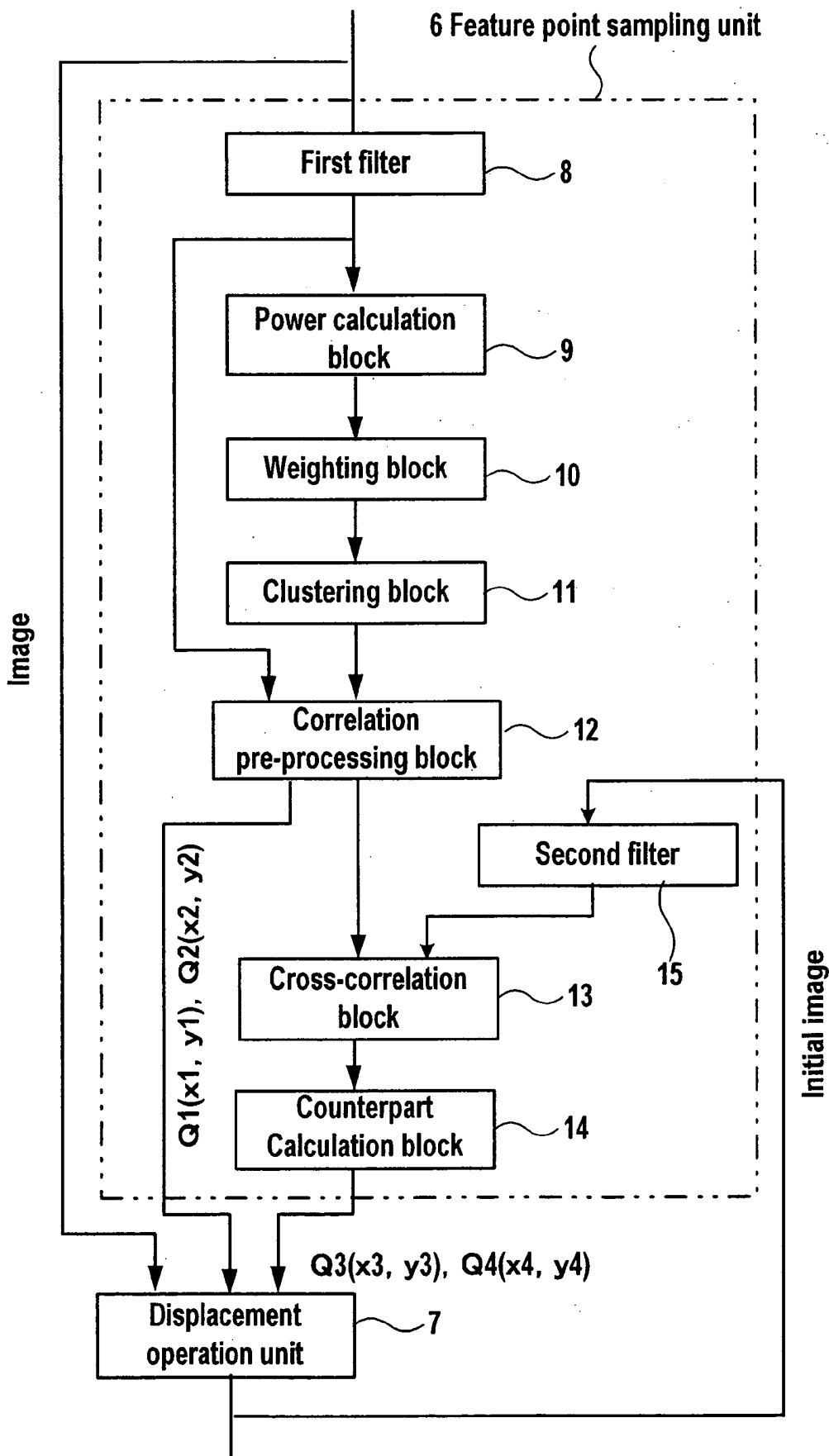

FIG. 3

Image data point  $P(x,y)$  within circle whose radius is  $r$ , after filtered

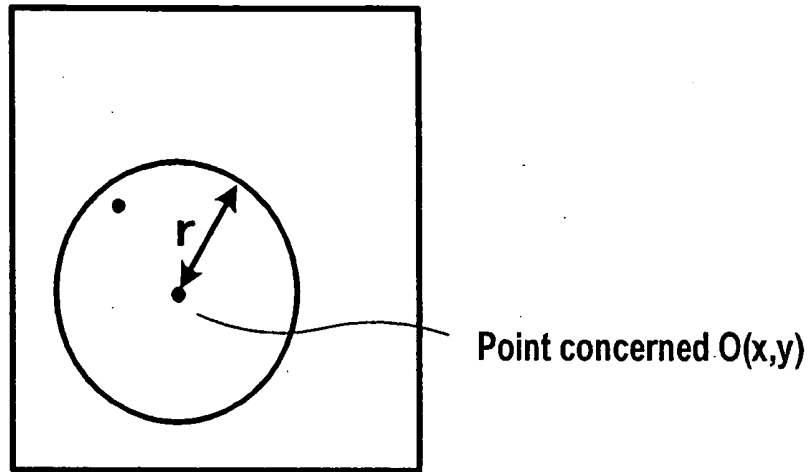

FIG. 4

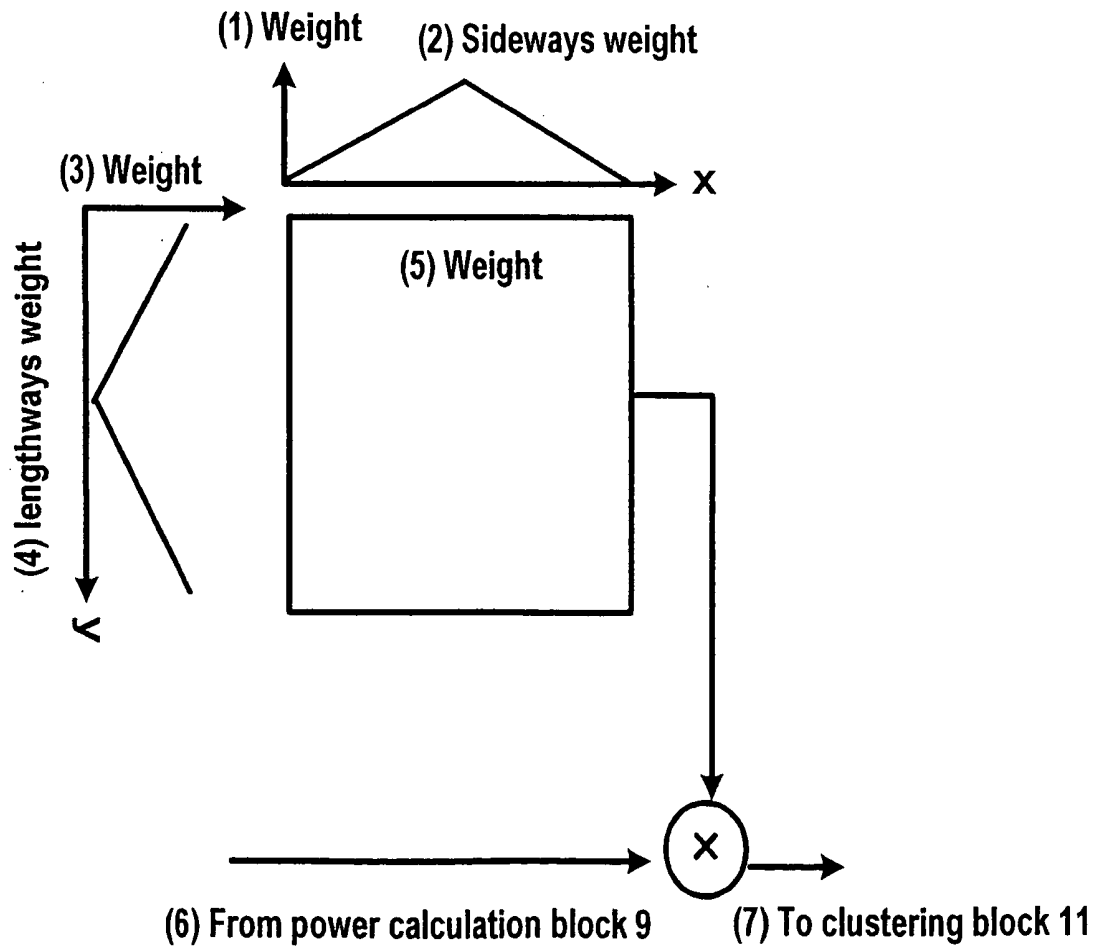

FIG. 5

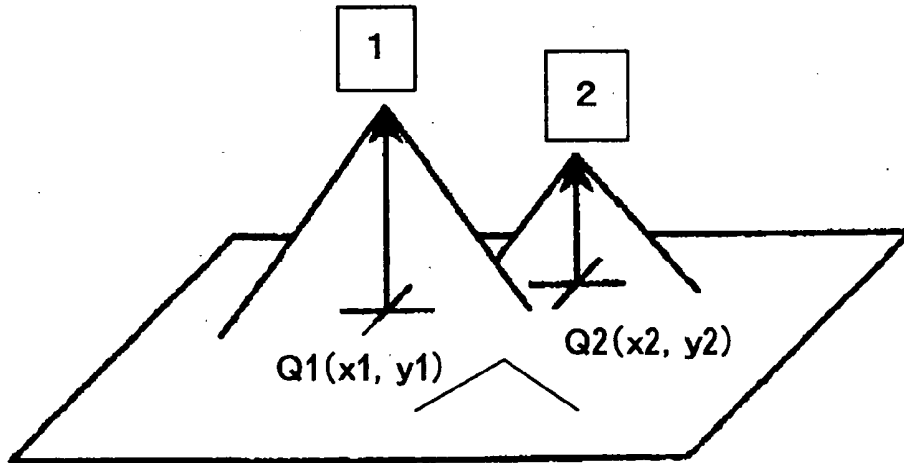

FIG. 6

(1) Gaussian distribution expressing standard deviation  $3\sigma$

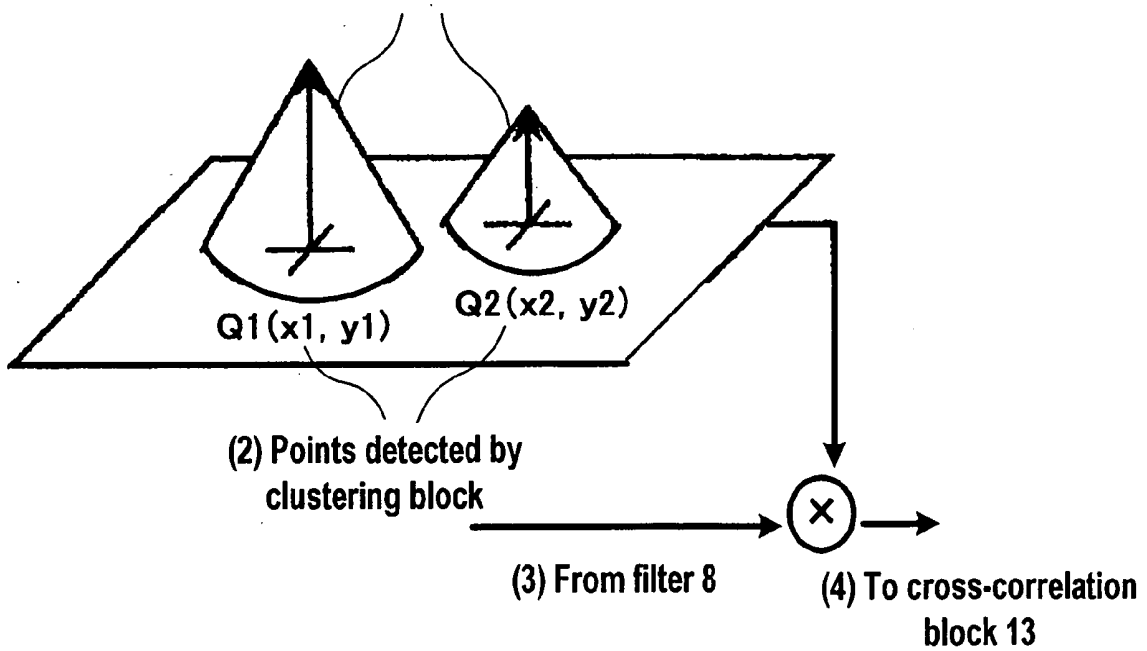
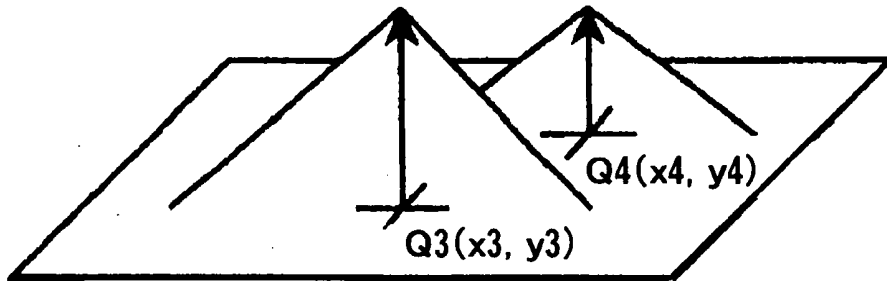

FIG. 7



Distribution of powers subjected to cross-correlation

FIG. 8

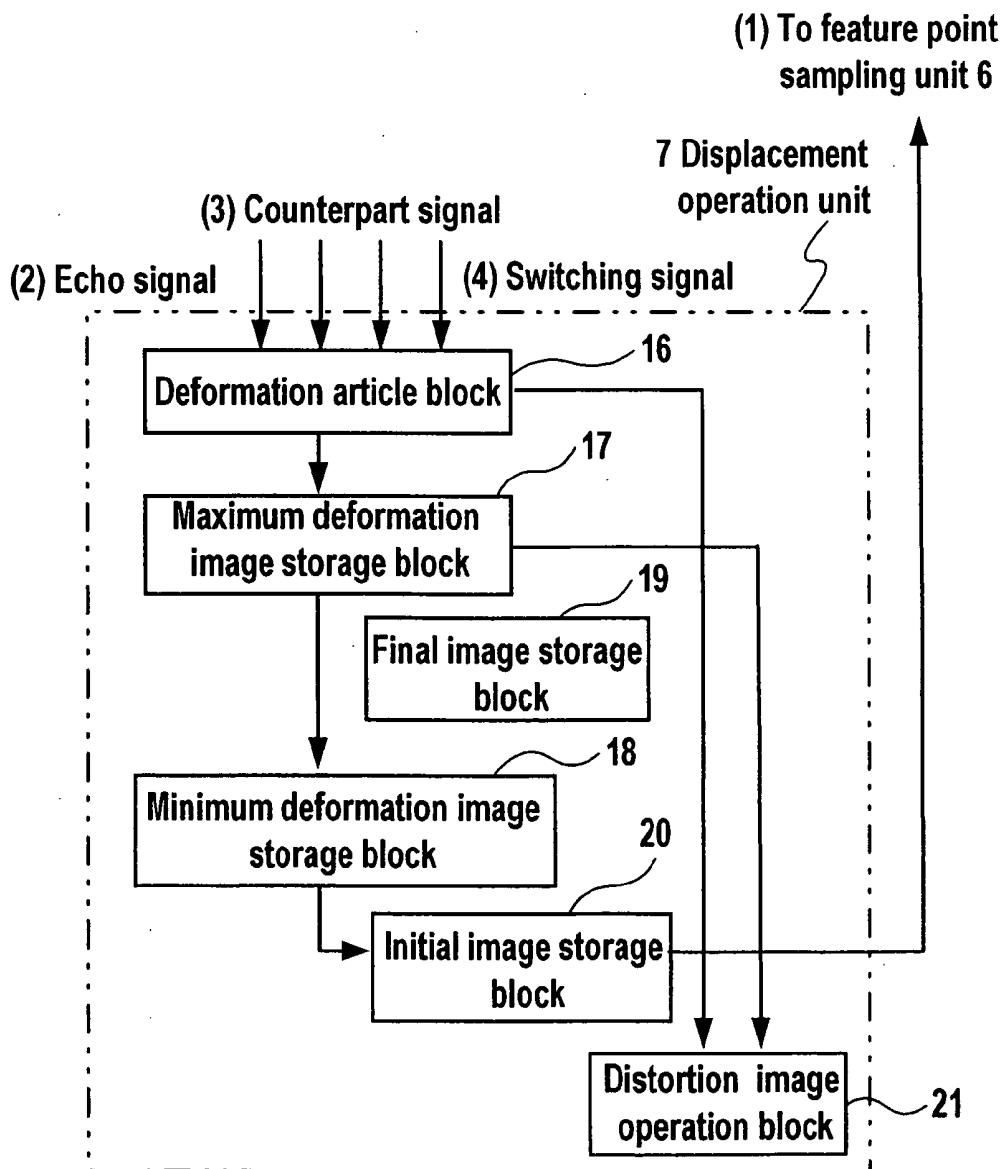

FIG. 9

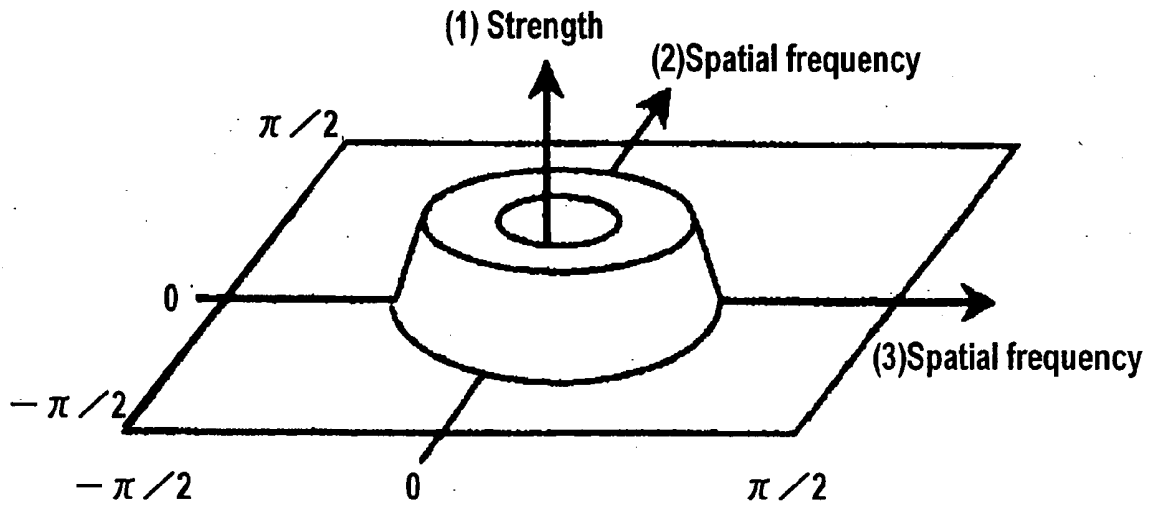

FIG. 10

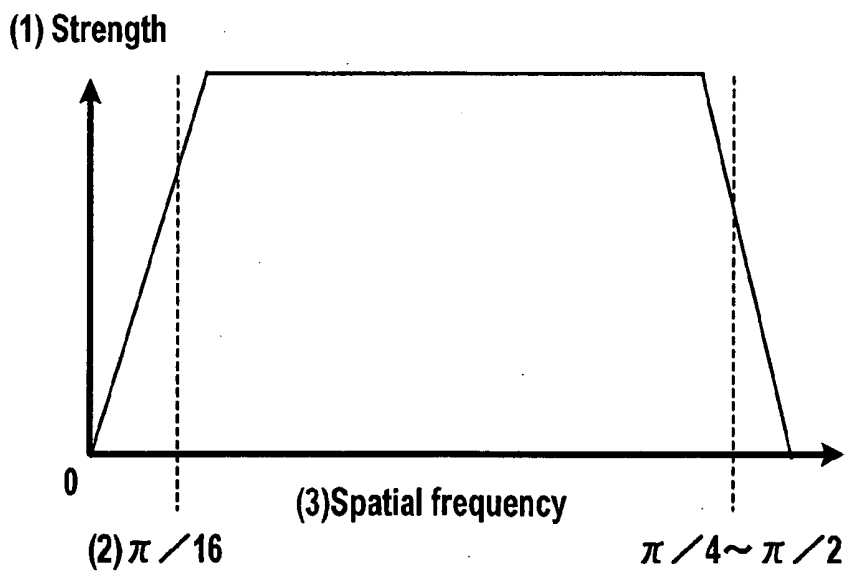

FIG. 11A

FIG. 11B

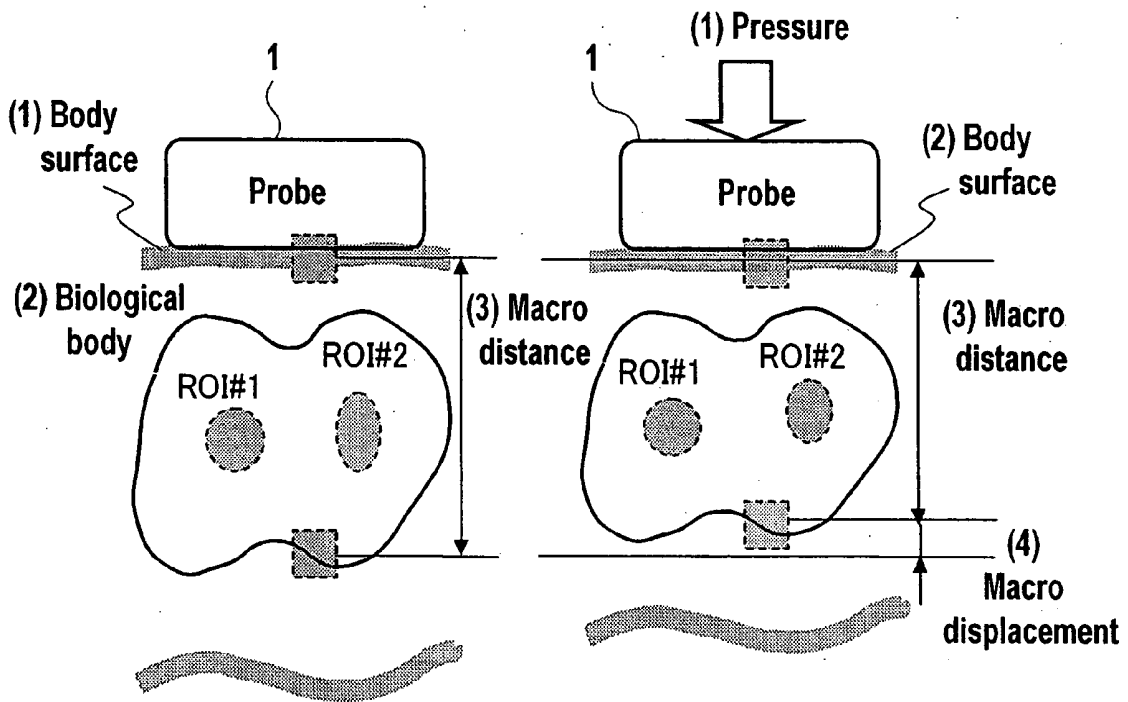

FIG. 12A

FIG. 12B

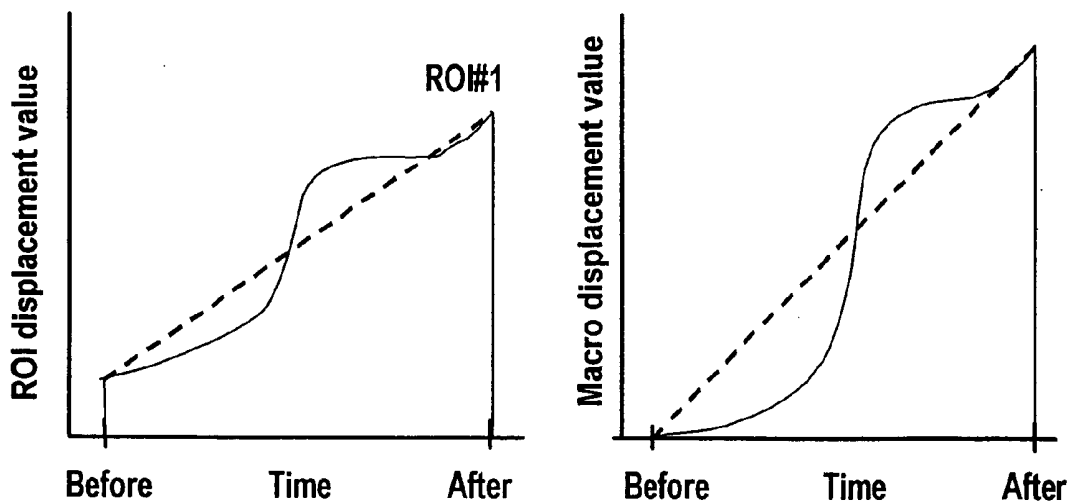

FIG. 13

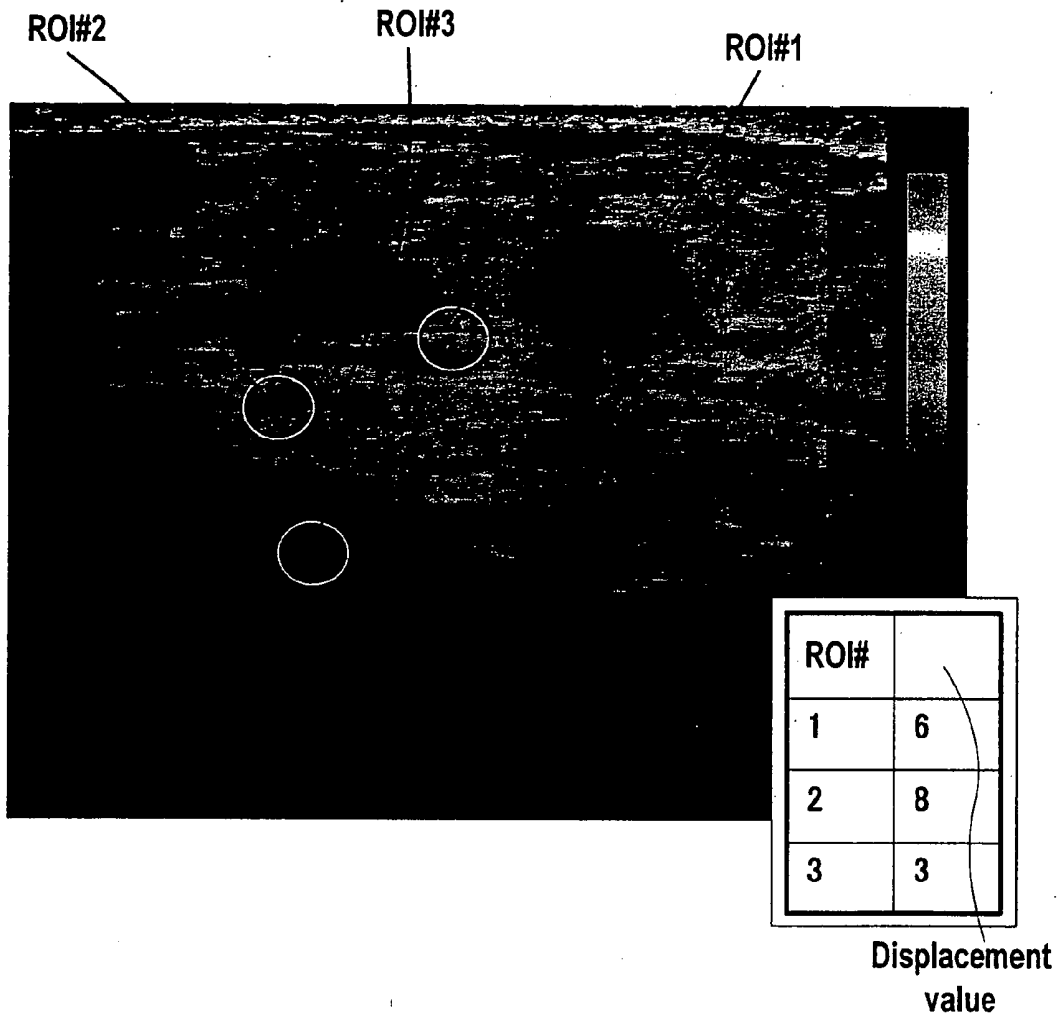

FIG. 14A

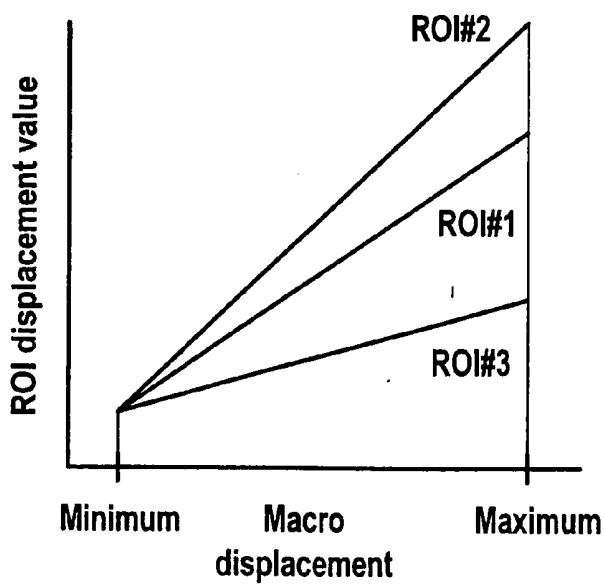

FIG. 14B

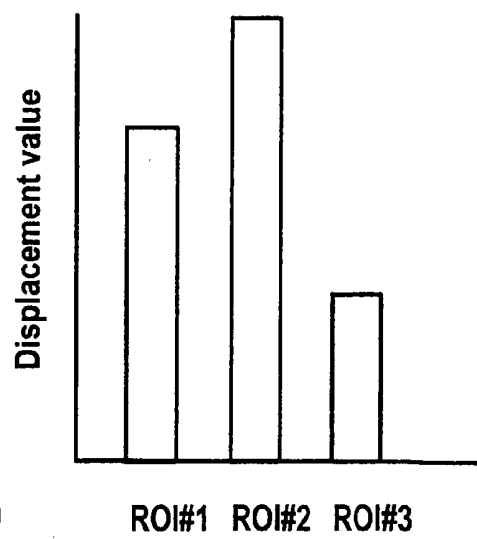
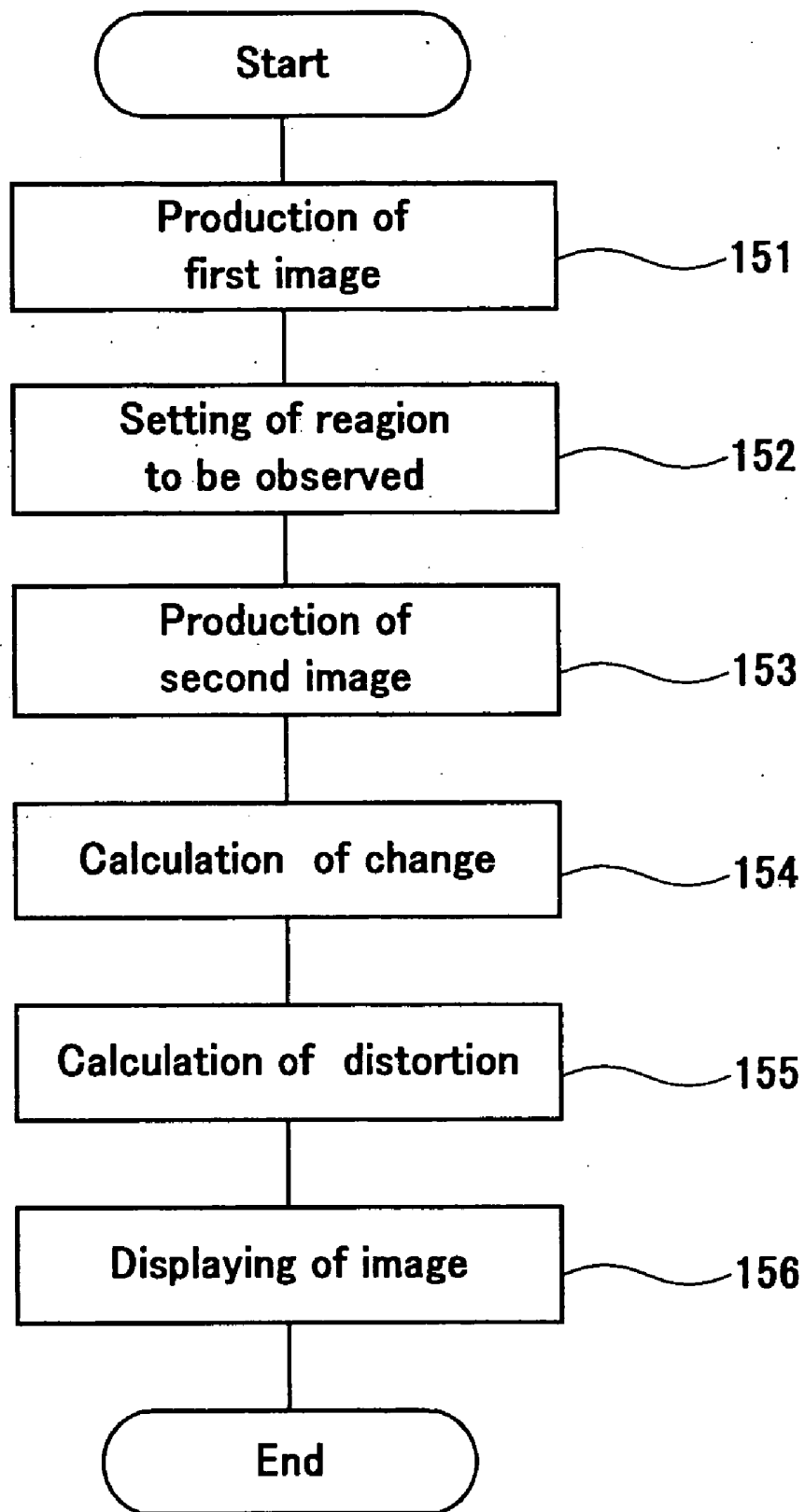

FIG. 15



## ULTRASONOGRAPH, METHOD FOR DISPLAYING INFORMATION ON DISTORTION OF BIOLOGICAL TISSUE IN ULTRASONIC IMAGE

### TECHNICAL FIELD

[0001] The present invention relates to a diagnostic ultrasound system which time-sequentially obtains ultrasonic images (ultrasonic cross-section images) while varying of pressure applied to a biological body (subject) using a probe, and which diagnoses hardness or softness of a biological tissue by utilizing a difference between ultrasonic images.

### BACKGROUND ART

[0002] In conventional diagnostic ultrasound systems, as described in Japanese Patent No. 3194947 and U.S. Pat. No. 5,143,070, when an examining physician such as a paramedic applies extraneous force to a body surface of a region-of-interest in a subject using a probe, a difference between ultrasonic cross-section images of different frames is produced in order to measure a displacement caused by applying the extraneous force. The conventional arts make it possible to diagnoses hardness or softness of each biological tissue in the region-of-interest.

[0003] However, the above patent documents merely describe displaying a contour image of distortion and Young's modules values. The conventional diagnostic ultrasound systems cannot cope with the need for time-sequentially acquiring ultrasonic images while varying the pressure applied a body surface by giving force to a probe, and producing a difference between ultrasonic images so as to visualize the hardness or softness of a biological tissue.

### DISCLOSURE OF INVENTION

[0004] The foregoing drawback is overcome by a diagnostic ultrasound system including: a probe for ultrasonic measurement by bringing said the probe into contact with a subject in a first state; a first image production means for producing a first image of the subject according to information received from the probe; an image display means for displaying the first image produced by the first image production means; a means for setting at least one piece of reference information on the first image displayed by the image display means; a second image production means for producing a second image of the subject according to information measured by bringing the probe into contact with the subject in a second state different from the first state; a variation operation means for calculating a change of the reference information, which is set on the first image by the setting means, into a counterpart visualized in the second image; a distortion operation means for calculating distortion information on a desired region-of-interest delineated in the second image according to the change calculated by the variation operation means; and a display control means for controlling the display of distortion information, which is calculated by the distortion operation means, on the image display means.

[0005] Moreover, aside from the foregoing hardware configuration, a computer system included in the diagnostic ultrasound system or a general-purpose computer may implement a method of displaying distortion information on a biological tissue observed in an ultrasonic image; the method including a step for time-sequentially storing dis-

placements of a biological tissue in a memory means, a step for time-sequentially reading the displacements from the memory, a step for displaying distortion information on a biological tissue so as to the displacements can be relatively observed.

### BRIEF DESCRIPTION OF THE DRAWINGS

[0006] FIG. 1 shows a schematic block diagram for explaining a diagnostic ultrasound system in accordance with an embodiment of the present invention;

[0007] FIG. 2 shows a schematic block diagram for explaining a feature point sampling unit included in the embodiment;

[0008] FIG. 3 shows a schematic drawing for explaining an image after filtered according to the embodiment;

[0009] FIG. 4 shows a schematic diagram for explaining a weighting unit included in the embodiment;

[0010] FIG. 5 shows a schematic drawing for explaining an action of a clustering unit included in the embodiment;

[0011] FIG. 6 shows a schematic drawing for explaining an action of correlation pre-processing unit included in the embodiment;

[0012] FIG. 7 shows a schematic drawing for explaining an action of a counterpart calculation block included in the embodiment;

[0013] FIG. 8 shows a schematic block diagram for explaining a displacement operation unit included in the embodiment;

[0014] FIG. 9 shows a schematic drawing for explaining an action of a first filter included in the embodiment;

[0015] FIG. 10 shows a schematic drawing for explaining an action of the first filter included in the embodiment;

[0016] FIG. 11 shows positional relationships between a region-of-interest in a subject and a probe attained before and after a pressure load is applied according to the embodiment;

[0017] FIG. 12 shows graphs concerned in the relationships of image display parameters to time;

[0018] FIG. 13 shows an example of the display on a display device;

[0019] FIG. 14 shows another example of the display on the display device different from that shown in FIG. 13; and

[0020] FIG. 15 shows a flowchart describing display of distortion information.

### BEST MODE FOR CARRYING OUT THE INVENTION

[0021] Referring to the appended drawings, an embodiment of the present invention will be described below.

[0022] FIG. 1 shows a schematic block diagram for explaining a diagnostic ultrasound system in accordance with an embodiment of the present invention.

[0023] The diagnostic ultrasound system in accordance with the embodiment includes: a probe (ultrasonic probe) **1**; an ultrasonic-wave transmitting/receiving unit **2** electrically

connected to the probe 1; a complex cine memory 3 electrically connected to the ultrasonic-wave transmitting/receiving unit 2; a frame memory 4 electrically connected to the complex cine memory 3; a display unit 5 electrically connected to the frame memory 4; a feature point (reference information) sampling unit 6 electrically connected to each of the complex cine memory 3 and frame memory 4; a displacement operation unit 7 electrically connected to each of the complex cine memory 3, frame memory 4, and feature point sampling unit 6, and a setting unit 30 electrically connected to the display unit 5.

[0024] An operation means has the capabilities of the complex cine memory 3, frame memory 4, feature point sampling unit 6, and displacement operation unit 7.

[0025] The probe 1 is a known probe which transmits or receives ultrasonic waves to or from a subject so that mechanically or electronically beam scan is carried out. The probe 1 includes one or more transducers (transducer elements) which serve as a source of ultrasonic waves and receive echoes reflected from a subject in a biological body.

[0026] The ultrasonic-wave transmitting/receiving unit 2 drives the probe 1 for generation of ultrasonic waves, and handles electric signals (echo signals) outputted from the transducer elements according to reflected echoes. The ultrasonic-wave transmitting/receiving unit 2 includes a known transmission pulser and transmission delay circuit for producing an ultrasonic beam to be transmitted from the probe 1 to a subject, a reception amplifier which amplifies echo signals received by the each transducers arrayed in the probe 1, and a phasing/adding circuit which arranges and adds the phase of the amplified input reflective echo signal.

[0027] In the complex cine memory 3, echo signals which are phased by the ultrasonic-wave transmitting/receiving unit 2 are time-sequentially stored as pieces of frame information representing a plurality of frames in the form of complex numbers or absolute values and phase angles.

[0028] The frame memory 4 produced image data by storing the frame information received from the complex cine memory 3 every scanning line according to ultrasonic beam. The frame memory 4 includes an affine transformation circuit which transforms scanning lines according to ultrasonic beam into scanning lines on a TV monitor, an image data memory, and an overlay circuit which displays color information, character string information, and graphic information on the display unit 5 while superposing them on one another.

[0029] The display unit 5 display an image according to a signal outputted from the frame memory 4. The display unit 5 has, for example, a TV monitor which receives a television signal representing a B-mode image (cross-section image) and on which the cross-section image is displayed.

[0030] The feature point sampling unit 6 extracts a feature point which copes with time-sequential data (time-series cross-section image) stored in the complex cine memory 3 and a pre-displacement (initial) cross-section image produced by the displacement operation unit and stored in a memory. Herein, the pre-displacement image is, as shown in FIG. 11A, an image based on echo signals acquired when the distance of a feature point or a region-of-interest, which is located at the deepest position relative to the vicinity of the probe, from the vicinity of the probe (macro distance) is

the largest. As shown in FIG. 11A, before the probe 1 is pressed against a subject, a biological tissue and a plurality of local region-of-interest (ROI#1 and ROI#2) do not change.

[0031] Meanwhile, as shown in FIG. 11B, a post-displacement image based on echo signals acquired when the macro distance of the region-of-interest, which is located at the deepest position, from the probe is the smallest. As shown in FIG. 11B, after the probe 1 is pressed against a subject, the biological tissue and the a plurality of local region-of-interest (ROI#1 and ROI#2) in the biological tissue are, compared with those shown in FIG. 11A, deformed as if to contract. The deformation is attributable to a micro displacement made by a region-of-interest and a macro displacement made by an entire biological body. The micro displacement and macro displacement have a difference indicated in FIG. 12. FIG. 12A shows the micro displacements made by a region-of-interest with the passage of time before and after pressure is applied to the body surface. FIG. 12B shows the macro displacements made by the biological body with the passage of time before and after pressure is applied to the body surface. In other words, the macro displacement and micro displacement show inherent time-series changes before and after pressure is applied. The feature point sampling unit 6 will be detailed later.

[0032] The displacement operation unit 7 compares the feature point and counterpart, which are extracted by the feature point sampling unit 6 before and after deformation, with each other, and calculates a variation of deformation made by a region-of-interest located at the feature point on the basis of the result of the comparison. The displacement operation unit 7 is designed to act according to whether a feature point and its counterpart are detected by the feature point sampling unit 6. The displacement operation unit 7 includes: a means for deforming information stored in the complex cine memory so as to the feature point and counterpart will be agreed with each other; a means for sequentially preserving a variation of movement derived from deformation (a variation of deformation) as a value of a displacement made by the region-of-interest; and a means for sequentially comparing the preserved displacement values with one another so as to calculate maximum and minimum displacement values indicating displacements made by the region-of-interest. Moreover, since only the maximum and minimum displacement values indicating displacements made by the region-of-interest are calculated, an intermediate value of all displacement values indicating displacements made by the region-of-interest or a displacement width by which the region-of-interest is displaced in total may be calculated. The displacement operation unit 7 will be detailed later.

[0033] The setting unit 30 is used to set arbitrary position in a cross-section image of a subject displayed on the display unit 5 as the position of a region-of-interest. The setting unit 30 is also used to define various settings of the diagnostic ultrasound system for production of images.

[0034] When the feature point and counterpart detected by the feature point sampling unit 6 are represented by mutually different coordinates, that is, the coordinates (positions) representing the feature point and counterpart are different from each other, the displacement operation unit 7 included in the present embodiment acts as described below. First,

information read from the complex cine memory 3 is deformed so as to the feature point and counterpart will be agreed with each other. The deformed information and the information that is not deformed are compared with each other in order to calculate a variation of deformation as a displacement value. Furthermore, maximum and minimum displacement values are preserved. An image in which the feature point is seen to have been displaced to a variation indicated with the minimum displacement value is preserved as an initial image, and an image in which the feature point is seen to have been displaced to a variation indicated with the maximum displacement value is preserved as a final image produced after displacement. On the other hand, if the coordinates (positions) of the feature point and counterpart had no difference, or if the counterpart of the feature point were not found, the displacement operation unit 7 would continue to preserve an initial image and a final image that are stored immediately previously.

[0035] A block may be interposed between the feature point sampling unit 6 and the displacement operation unit 7: the block for verifying whether the counterpart of a feature point is found or whether the feature point has moved. Nevertheless, the same advantage as the foregoing one can be provided by the displacement operation unit 7.

[0036] Next, referring back to FIG. 1, a description will be made of acquisition of images showing different distortions, which are derived from application of pressure to a subject, using the diagnostic ultrasound system in accordance with the present invention.

[0037] According to the present embodiment, the probe 1 is used to apply pressure during transmission or reception of ultrasonic waves in order to produce images. Echo signals which are signals corresponding to echoes received by the transducers are sequentially transferred to the ultrasonic-wave transmitting/receiving unit 2. After the echo signals are phased and added up, a resultant signal is transmitted to the complex cine memory 3. In the complex cine memory 3, a plurality of frames, that is, a plurality of cross-section images is time-sequentially stored together with their phase information. The stored cross-section images are sequentially outputted to each of the frame memory 4, feature point sampling unit 6, and displacement operation unit 7.

[0038] The feature point sampling unit 6 compares an image read from the complex cine memory 3 with a pre-displacement image received from the displacement operation unit 7, and extracts a feature point and its counterpart. The coordinates of the feature point and counterpart extracted by the feature point sampling unit 6 are outputted to the displacement operation unit 7. The image read from the complex cine memory 3 is deformed so that the feature point and counterpart will be agreed with each other. The image that has been deformed and the image that is not deformed are compared with each other in order to calculate a variation of deformation. The variation of deformation is regarded as a displacement value. The displacement value is compared with the maximum and minimum displacement values which are stored. Only when the displacement value exceeds the maximum value or is smaller than the minimum value, the maximum or minimum value is updated to the newly calculated displacement value. At this time, if the updated displacement value were the minimum displacement value, the previous initial image would be updated to

the image in which the feature point is seen to have been displaced to a variation indicated with the minimum displacement value. On the other hand, when the updated displacement value were the maximum displacement value, the previous post-displacement final image would be updated to the image in which the feature point is seen to have been displaced to a variation indicated with the maximum displacement value. The maximum and minimum displacement values are transmitted as the maximum and minimum displacement values indicating the variations of displacements made by a region-of-interest to the frame memory 4. The initial image is transmitted as an image, in which the region-of-interest is seen to have been displaced by a variation indicated with the minimum displacement value, to the frame memory 4. Moreover, the post-displacement final image is transmitted as an image, in which the region-of-interest is seen to have been displaced by a variation indicated with the maximum displacement value, to the frame memory 4. Consequently, an image for displaying is constructed according to a cross-section image which is transmitted from both of the complex cine memory 3 and measured in real time, and a distortion image produced based on the maximum and minimum displacement values transmitted from the displacement operation unit 7 and the initial image and post-displacement final image. The image which is constructed for displaying is then displayed on the display area of the display unit 5.

[0039] For example, a difference image is produced based on the post-displacement final image and initial image according to a known technique. The difference image is displayed as the distortion image together with a cross-section image, which is measured in real time, on the display unit 5.

[0040] The distortion image is, as shown in FIG. 13, displayed in gray-scale in colors while superposed on a cross-section image. A plurality of region-of-interest ROI#1, ROI#2, ROI#3 is delineated as desired region-of-interest by use of the setting unit 30. Namely, the displacement values indicating the variations of displacements made by the designated regions of interest ROI#1, ROI#2, and ROI#3 are displayed as shown in the right lower part of the drawing. Data representing a distortion image (a difference between cross-section images) are produced through arithmetic operations so as to display of the numerical values. For example, a known character string generator converts the image data into characters, and the characters are displayed in the cells in a table allocated to ROI1, ROI2, and ROI3. Because the cross-section image and distortion image are measured in real time, an instantaneous value that updates in real time is displayed. Instantaneous values may be sequentially stored in a memory in order to calculate statistics including a cumulative value and an average, and the statistics may be displayed. The statistics including the cumulative value, average, variance, and standard deviation may be calculated according to a known statistical data calculating method. Moreover, the number of statistics displayed may not be one, but a plurality of statistics, for example, the instantaneous value and average may be displayed in combination. Moreover, a macro displacement that is a displacement made by a biological body may also be displayed.

[0041] Moreover, instead of the numerical values shown in FIG. 13, or in combination with them, a graph shown in

**FIG. 14** may be displayed. For display of the graph, data representing a distortion image (a difference between cross-section image data items) is calculated through arithmetic operations, and a known graph generator converts the calculated data into a graph that can be displayed in a desired display area on the display unit. The graph produced is then displayed. **FIG. 14A** shows the relationship of displacements based on region-of-interest to the macro displacement based on a biological body. The graph makes it possible to verify at sight which of the region-of-interest exhibit local hardness. For example, in this example, because the displacement based on the region-of-interest ROI#3 is small, it means that a part of the region-of-interest ROI#3 is hard and suspected of being a malignant tumor. Consequently, the graph can provide a doctor with diagnostic information signifying that close examination is needed. Moreover, as shown in **FIG. 14B**, a bar graph permitting comparison of displacements made by regions of interest may be adopted. Even the bar graph can provide a doctor with diagnostic information similar to the one shown in **FIG. 4a**. Incidentally, aside from the bar graph, any of various graphs including a line graph, a solid bar graph, and a solid line graph, and a circular graph may be adopted.

[0042] Various display forms are conceivable. Namely, region-of-interest may be displayed in different manners, that is, in different colors or shapes. A locus of points indicating the position of an image attained before application of pressure and the positions of the image displaced after application of pressure may be displayed. The images produced before and after application of pressure may be displayed in different colors. One of the images produced before and after application of pressure may be displayed with a solid line and the other may be displayed with a dashed line. The images produced before and after application of pressure may be displayed while being superposed on each other. The images produced before and after application of pressure may be displayed side by side. Any of the display forms may be adopted independently or in combination.

[0043] Thus, a portion of an image showing different hardness can be displayed while being clearly distinguished from the other portion. Moreover, a distortion image can be produced without the necessity of a special stress application device. Wherein, the maximum and minimum displacement values and the distortion image may be displayed together with a cross-section image sent from the complex cine memory 3, that is, a real-time cross-section image. Alternatively, the maximum and minimum displacement values and the distortion image may be displayed after acquisition of cross-section images is completed or responsively to handling of the setting unit 30.

[0044] As mentioned above, in the diagnostic ultrasound system of the present embodiment, the probe 1 is used to directly give a pressure to a region-of-interest. The displacement operation unit 7 uses cross-section images, which are sequentially measured, to calculate the maximum and minimum displacement values, which indicate maximum and minimum displacements made by a region-of-interest, in real time. Any special application device is unnecessary, and the time required for application of pressure is saved. Consequently, the time required for diagnosis is shortened. Eventually, a load incurred by an examining physician or a subject can be minimized.

[0045] Moreover, because an examining physician need not make a subjective judgment, objective ultrasonic examination can be achieved. Consequently, the time required for examination will become even despite a difference in experience in ultrasonic examination.

[0046] **FIG. 2** is an explanatory diagram schematically showing the configuration of the feature point sampling unit included in the present embodiment. As apparent from **FIG. 2**, the feature point sampling unit 6 included in the present embodiment comprises: a first filter 8; a power calculation block 9 electrically connected to the first filter 8; a weighting block 10 electrically connected to the power calculation block 9; a clustering block 11 electrically connected to the weighting block 10; a correlation pre-processing block 12 electrically connected to each of the first filter 8 and clustering block 11A cross-correlation block 13 electrically connected to each of the correlation pre-processing block 12 and a second filter 15; a counterpart calculation block 14 electrically connected to the cross-correlation block 13; and the second filter 15 electrically connected to the displacement operation unit 7.

[0047] Referring to **FIG. 2**, the first filter 8 is a known filter that selectively passes image data which represents certain spatial frequencies and which is read from the complex cine memory 3. According to the present embodiment, the first filter 8 offers, as shown in **FIG. 9**, a passband in the form of a concentric circle with a spatial frequency of 0 as a center point. **FIG. 10** is an explanatory diagram concerning the passband shown in **FIG. 9**. As apparent from **FIG. 10**, the first filter 8 included in the present embodiment is a bandpass filter that has a lower-limit cutoff frequency set to about  $\pi/16$  and has an upper-limit cutoff frequency set to a range from about  $\pi/4$  to  $\pi/2$ .

[0048] The power calculation block 9 is a means for calculating the powers of image data sent from the first filter 8. As shown in **FIG. 3**, the sum of the squares of data items at all points  $P(x, y)$  within a circle having a radius  $r$  with a point concerned  $O(x, y)$  as a center thereof is calculated as the power of data at the point  $O$ . The power calculation unit 9 performs this calculation on every point  $(x, y)$ .

[0049] The weighting block 10 is an operation means for applying a predetermined weight to the distribution of powers calculated by the power calculation block 9. The weight to be applied is, for example, as shown in **FIG. 4**, increased toward to a sideways center, and is decreased toward a lengthways center.

[0050] The clustering block 11 is a means for detecting two peak points in the distribution of powers sent from the weighting block 10, and retrieving values associated with the peak points. For example, as shown in **FIG. 5**, the coordinates  $(x_1, y_1)$  of the largest peak point and the associated value  $Q_1$  are retrieved as the first data, and the coordinates  $(x_2, y_2)$  of the second largest peak point and the associated value  $Q_2$  are retrieved as the second data. A known propagation deletion method or the like may be adopted as a method of separating or identifying a peak point from a two-dimensional distribution having a plurality of peak points.

[0051] The correlation pre-processing block 12 is a means for fitting a predetermined weighting function to the coordinates of the two peak points and the associated values that

are detected by the clustering block **11**. For example, when a Gauss' curve expressing a Gaussian distribution is adopted as the graph of the weighting function, the weighting function is applied so that a Gaussian distribution expressing a standard deviation of  $3\sigma$  will be produced to have each of the two peak points  $Q1(x1, y1)$  and  $Q2(x2, y2)$ , which are associated with the values  $Q1$  and  $Q2$ , as a center thereof. However, the weighting function is not limited to the Gauss' curve expressing the Gaussian distribution. Alternatively, the Hamming window function, Hanning window function, or Blackman-Harris window function will do.

[0052] The cross-correlation block **13** is a known means for calculating correlations between the distribution of weights sent from the correlation pre-processing block **12** and image data sent from the second filter **15**.

[0053] The counterpart calculation block **14** searches a distribution of correlations received from the cross-correlation block **13** for two peak points and their associated values. The counterpart calculation block **14** performs arithmetic operations similar to those performed by the clustering block **11**. As a result of the arithmetic operations performed by the counterpart calculation block **14** included in the present embodiment, for example, as shown in **FIG. 7**, the coordinates  $(x3, y3)$  and  $(x4, y4)$  representing the two peak points and the values  $Q3$  and  $Q4$  associated therewith are determined.

[0054] The second filter **15** is a means for selectively passing joint image data that represents certain spatial frequencies and is sent from the displacement operation unit **7**. The second filter **15** performs processing similar to the one performed by the first filter **8**.

[0055] Next, actions to be performed by the feature point sampling unit **6** included in the present embodiment will be described in conjunction with **FIG. 2**.

[0056] The first filter **8** selectively passes image data that is carried by a signal sent from the complex cine memory **3** and that represents certain spatial frequencies. Specifically, image data representing spatial frequencies ranging from  $\pi/16$  to a range from  $\pi/4$  to  $\pi/2$  is sampled and transmitted to the power calculation block **9**. The power calculation block **9** handles the received image data so as to calculate the sum of the squares of data items at all points  $P(x, y)$  within a circle having a radius  $r$  with respect to each of points concerned  $O(x, y)$ . The calculated sums are transmitted as the powers of the data at all the points concerned  $O$  to the weighting block **10**. The weighting unit **10** serves as an operation means for applying a predetermined weight to data representing the powers. At this time, the weight to be applied will be increased toward the sideways center of the data, and decreased toward the lengthways center of the data. The resultant data are transmitted to the clustering unit **11**. The data received by the clustering unit **11** are subjected to, for example, known propagation deletion so that the coordinates of the two peak points and the associated values thereof will be detected. The detected coordinates and values are transmitted to the correlation pre-processing unit **12**.

[0057] The correlation pre-processing unit **12** also receives an output of the first filter **8**. The coordinates of the two peak points and the associated values thereof which are detected by the clustering block **11** are weighted according to the predetermined weighting function. The resultant data

is transmitted to the cross-correlation block **13**. The cross-correlation block **12** calculates correlations (or a distribution of correlation values) of the received data with image data sent from the second filter, and transmits the distribution of correlations to the counterpart detection block **14**. The counterpart detection block **14** having received the distribution of correlations performs arithmetic operations similar to those performed by the clustering block **11** so as to detect the coordinates of two peak points and the associated values thereof. Consequently, the coordinates  $(x3, y3)$  and  $(x4, y4)$  of the two peak points and the values  $Q3$  and  $Q4$  thereof are transmitted to the displacement operation unit **7**.

[0058] **FIG. 8** is an explanatory diagram schematically showing the configuration of the displacement operation unit included in the present embodiment.

[0059] As apparent from **FIG. 8**, the displacement operation unit **7** included in the present embodiment comprises a deformation arithmetic block **16**, a maximum deformation image storage block **17**, a minimum deformation image storage block **18**, a final image storage block **19**, an initial image storage block **20**, and a distortion image operation block **21**.

[0060] Referring to **FIG. 8**, the deformation arithmetic block **16** is a means for calculating as data signals distance between a feature point and a counterpart which are associated with each other by the counterpart calculation block **14** and a direction of movement made by the feature point.

[0061] The maximum deformation image storage block **17** is a means for identifying and storing beam data signals of an image in which the feature points is seen to have deformed to the greatest extent.

[0062] The minimum deformation image storage block **18** is a means for identifying and storing beam data signals of an image in which a distance between feature points including codes is smallest.

[0063] The final image storage block **19** is a means for storing an image in which a change of the feature points is greatest. The stored image is transmitted to the distortion image operation block **21**.

[0064] The initial image storage block **20** is a means in which an initial image is updated with data (image data) identified by the minimum deformation storage block **18**, and stored as new initial image data. The stored image data is transmitted to each of the feature point sampling unit **6**, deformation arithmetic block **16**, and distortion image operation block **21**.

[0065] The distortion image operation block **21** is a means for visualizing the displacement (distortion) made by a biological tissue using the images in which the feature point is seen to have been distorted to the variations indicated with the maximum and minimum displacement values.

[0066] As mentioned above, the displacement operation unit **7** calculates a distance between a feature point and its counterpart that are associated with each other by the counterpart calculation block **14** on the basis of the coordinates of two pairs of peak points and the associated values thereof (distributions of powers). Thus, the largest and smallest distances are detected.

[0067] Moreover, aside from the foregoing hardware configuration, a computer included in the diagnostic ultrasound

system may be used to implement a method of time-displaying displacements made by a biological tissue. Namely, displacement values indicating displacements made by a biological tissue of a subject are time-sequentially stored in a storage means, and time-sequentially read from the storage means in order to visualize the displacement values relatively.

[0068] When many patients are examined during, for example, mass screening, the diagnostic ultrasound system is used to measure and store a plurality of cross-section images before and after each of the subjects is pressed using the probe. Thereafter, the plurality of stored cross-section images is used to calculate and display displacement values. Measurement of displacement values and diagnosis can be performed independently of each other in a concentrated manner. Consequently, an efficient observation environment can be provided.

[0069] FIG. 15 describes a concrete procedure for implementing a distortion displaying method.

[0070] <Producing a first image> Ultrasonic measurement is performed with the probe touched to a subject in a first state in order to produce a first image of the subject (Step 151).

[0071] <Delineating a region to be observed> A region to be observed (reference information) is delineated in the produced first image (Step 152). The delineation falls into manual delineation in which a region to be observed is delineated in an image displayed on the display screen, and automatic delineation in which a region in which a distance to a feature point (macro distance) is equal to or larger than a specified value is delineated as a region to be observed. When the automatic delineation technique is adopted, the first image produced by the first image production means is displayed on the image display means, and at least one region-of-interest is delineated in the first image.

[0072] When the densities of portions of an image are different from each other, for example, when an image shows a normal tissue and an abnormal tissue, a region supposed to be the abnormal tissue and identified with the density is sampled as a feature point, and the sampled feature point and its surroundings are designated as a region-of-interest.

[0073] <Producing a second image>, Ultrasonic measurement is performed with the probe touched to the subject in a second state different from the first state in order to produce a second image of the subject (Step 153).

[0074] <Calculating a change> A change of the coordinates of an observation point in the second image from the coordinates of a counterpart in the first image is calculated (Step 154).

[0075] <Calculating a distortion> A distortion made by a desired region-of-interest is calculated based on the calculated change (Step 155).

[0076] <Displaying an image> The calculated distortion information is displayed (Step 156). The Step 153 and subsequent steps may be repeated in order to display a time-sequentially varying second image. The display form has been described previously.

[0077] Moreover, the present invention may be implemented in a program for displaying displacements, which are made by a biological tissue, together with an ultrasonic image. In this case, the program is installed in a computer

system comprising an input unit that includes a known keyboard, a known mouse, and an interface via which data is received from the diagnostic ultrasound system, a processing unit such as a processor that acts according to a program, and an output unit that includes a monitor on which an image is displayed according to the result of processing. Displacement values indicating displacements made of a biological tissue of a subject are time-sequentially stored in a storage means, and time-sequentially read from the storage means in order to calculate distortion information from the displacement values.

[0078] Consequently, when a personal computer owned by an examining physician or a paramedic is adopted as the computer system, the foregoing displaying method can be implemented. Moreover, a program capable of editing the results of diagnosis may be used to produce electronic clinical recordings. Moreover, when the personal computer supports a network environment, secondary utilization of data is enabled, for example, diagnostic information may be provided for individual patients. Wherein, because diagnostic information is personal information that is ranked as a top secret, preferably the information is protected with a perfect security facility.

[0079] The invention made by the present inventor has been described in conjunction with the embodiment. The present invention is not limited to the embodiment but may be modified in various manners without a departure from the gist thereof.

[0080] The present invention provides an advantage that ultrasonic images are time-sequentially acquired by varying the pressure imposed on the probe, and the softness or hardness of a biological tissue is visualized using a difference between ultrasonic images.

#### 1. A diagnostic ultrasound system comprising:

- a probe for measuring a subject using ultrasound by bringing said probe into contact with a subject in a first state;
- a first image production means for producing a first image of said subject according to information sent from said probe;
- an image display means for displaying said first image produced by said first image production means;
- a means for setting at least one piece of reference information on said first image displayed by said image display means;
- a second image production means for producing a second image of said subject according to information measured by bringing the probe into contact with said subject in a second state different from said first state;
- a variation operation means for calculating a change of said reference information, which is set on said first image by said setting means, into a counterpart visualized in said second image;
- a distortion operation means for calculating distortion information on a desired region-of-interest in said second image according to said change calculated by said variation operation means; and
- a display control means for controlling the display of the distortion information, which is calculated by said distortion operation means, on said image display means.

2. A diagnostic ultrasound system according to claim 1, wherein said variation operation means calculates a locus of points starting with the point of the reference information set on said first image and ending with the point of the reference information in said second image, and said display control means controls the display of the calculated locus on said image display means.

3. A diagnostic ultrasound system according to claim 1, wherein said variation operation means calculates a change of said desired region-of-interest set on said second image, and said display control means controls the display of the calculated change of said region-of-interest, on said image display means.

4. A diagnostic ultrasound system according to claim 3, further comprising a region-of-interest setting means for setting a desired region-of-interest on said first image, wherein a change of the region-of-interest delineated in said first image into a counterpart visualized in said second image is calculated and displayed on said image display means.

5. A diagnostic ultrasound system according to claim 1, wherein said reference information set by said setting means is visualized in said first image to be located at the deepest point from the vicinity of said probe.

6. A diagnostic ultrasound system according to claim 1, wherein said reference information inputted by said setting means is automatically set in a predetermined portion of said first image.

7. A diagnostic ultrasound system according to claim 1, wherein said display control means displays an image of said desired region-of-interest on said image display means in a different display form, that is, in a different color or shape.

8. A diagnostic ultrasound system according to claim 1, wherein said setting means set said reference information on said first image displayed by said image display means.

9. A diagnostic ultrasound system according to claim 1, further comprising a graph production means for producing a graph indicating the relationship between at least one of statistics including an instantaneous value of a displacement relative to a region in contact with said probe, a cumulative value of displacements, and an average of displacements, and at least one of statistics including a displacement relative to a region-of-interest, wherein

said display control means displays the graph, which is produced by said graph production means, on said image display means.

10. A diagnostic ultrasound system according to claim 1, further comprising a character string production means for producing a character string, which represents a numerical value of at least one of statistics including an instantaneous value of a displacement relative to region-of-interest in said subject, a cumulative value of displacements, and an average of displacements, wherein said display control means displays the character string, which is produced by said character string production means, on said image display means.

11. A method for displaying information on distortion of biological tissue in ultrasonic image, comprising:

a first image production step for measuring a subject using ultrasound by bring a probe into contact with a subject in a first state, and producing a first image of said subject according to the measurement information;

an image display step for displaying said first image produced at said first image production step;

a step for setting at least one reference information by delineating it in said first image displayed at said image display step;

a second image production step for measuring a subject using ultrasound by bring said probe into contact with said subject in a second state different from said first state, and producing a second image of said subject according to the measurement information;

a variation operation step for calculating a change of said reference information, which is set on said first image at said setting step, into a counterpart visualized in said second image;

a distortion operation step for calculating distortion information on a desired region-of-interest, which is setting on said second image, according to the variation calculated at said variation operation step; and

a display control step for controlling the display of said distortion information, which is calculated at said distortion operation step, at said image display step.

12. A method of displaying distortion information on a biological tissue together with an ultrasonic image according to claim 11, wherein: at said variation operation step, a locus of points starting with the point of said reference information set on said first image and ending with the point of a counterpart visualized in said second image is calculated; and at said display control step, the display of said calculated locus at said image display step is controlled.

13. A method of displaying distortion information on a biological tissue together with an ultrasonic image according to claim 11, wherein: at said variation operation step, a change relative to said desired region-of-interest in said second image is calculated; and at said display control step, the display of the calculated change relative to said region-of-interest at said image display step is controlled.

14. A method of displaying distortion information on a biological tissue together with an ultrasonic image according to claim 13, further comprising a step for setting a region-of-interest by delineating a desired region-of-interest in said first image, wherein a change is calculated and displayed; the change is that relative to said region-of-interest delineated in said first image into a counterpart visualized in said second image.

15. A method of displaying distortion information on a biological tissue together with an ultrasonic image according to claim 11, wherein said reference information set at said setting step is visualized in said first image to be located at the deepest point from the vicinity of said probe.

16. A method of displaying distortion information on a biological tissue together with an ultrasonic image according to claim 11, wherein said reference information set at said setting step is automatically delineated in a predetermined portion of said first image.

17. A method of displaying distortion information on a biological tissue together with an ultrasonic image according to claim 11, wherein at said display control step, an image of said desired region-of-interest is displayed in a different display form, that is, in a different color or shape.

专利名称(译)	超声波检查仪，用于显示超声图像中生物组织变形信息的方法		
公开(公告)号	<a href="#">US20050187470A1</a>	公开(公告)日	2005-08-25
申请号	US10/516598	申请日	2003-06-04
[标]申请(专利权)人(译)	久保田JUN BABA广隆		
申请(专利权)人(译)	久保田JUN BABA广隆		
当前申请(专利权)人(译)	HITACHI, LTD.		
[标]发明人	KUBOTA JUN BABA HIROTAKA		
发明人	KUBOTA, JUN BABA, HIROTAKA		
IPC分类号	A61B8/08 G01S7/52 A61B8/00		
CPC分类号	A61B5/0048 A61B8/08 A61B8/463 G01S7/52074 A61B8/485 G01S7/5205 A61B8/469 A61B5/0053		
优先权	2002162288 2002-06-04 JP		
其他公开文献	US7927279		
外部链接	<a href="#">Espacenet</a> <a href="#">USPTO</a>		

摘要(译)

一种超声波检查器，包括用于通过使探针与处于第一状态的对象接触而进行测量的探针，用于根据从探针发送的信息创建对象的第一图像的第一图像创建装置，用于显示所创建的第一图像的图像显示装置第一图像创建装置，用于设置关于由图像显示装置显示的第一图像的至少一条参考信息的装置，第二图像创建装置，用于通过将探针带入所收集的测量信息来创建对象的第二图像在与第一状态不同的第二状态下与对象接触，用于在第二图像中基于在第二图像中设置的参考信息的变化来收集关于第二图像中的期望感兴趣区域的失真的信息的装置。第一图像由设定装置和显示控制装置控制由变阻器收集的失真信息的显示图像显示装置上的收集装置。

