



U.S. PATENT DOCUMENTS

5,590,658 A 1/1997 Chiang et al.  
 5,617,866 A 4/1997 Marian, Jr.  
 5,622,177 A \* 4/1997 Breimesser et al. .... 600/459  
 5,627,536 A 5/1997 Ramirez  
 5,676,147 A 10/1997 Petrofsky et al.  
 5,678,551 A 10/1997 Stevens  
 5,690,114 A 11/1997 Chiang et al.  
 5,817,024 A 10/1998 Ogle et al.  
 5,820,549 A 10/1998 Marian, Jr.  
 5,839,442 A 11/1998 Chiang et al.  
 5,957,846 A 9/1999 Chiang et al.  
 5,964,709 A 10/1999 Chiang et al.  
 5,997,479 A 12/1999 Savord et al.  
 6,013,032 A \* 1/2000 Savord ..... 600/443  
 6,016,285 A 1/2000 Wright et al.  
 6,029,116 A \* 2/2000 Wright et al. .... 702/32  
 6,102,863 A 8/2000 Pflugrath et al.  
 6,106,472 A 8/2000 Chiang et al.  
 6,126,602 A 10/2000 Savord et al.  
 6,126,606 A 10/2000 Bergstoel  
 6,142,946 A 11/2000 Hwang et al.  
 6,248,073 B1 6/2001 Gilbert et al.  
 6,371,918 B1 4/2002 Bunce  
 6,375,617 B1 \* 4/2002 Fraser ..... 600/443  
 6,491,634 B1 \* 12/2002 Leavitt et al. .... 600/447  
 6,527,722 B1 3/2003 Fazioli et al.  
 6,530,887 B1 3/2003 Gilbert et al.  
 6,537,219 B2 3/2003 Poland et al.  
 6,540,685 B1 4/2003 Rhoads et al.  
 6,544,175 B1 \* 4/2003 Newman ..... 600/437

6,575,908 B2 6/2003 Barnes et al.  
 6,582,367 B1 6/2003 Robinson et al.  
 6,589,179 B2 7/2003 Criton et al.  
 6,612,987 B2 9/2003 Morsy et al.  
 6,629,928 B1 10/2003 Dolan et al.  
 6,635,019 B2 10/2003 Davidsen  
 6,648,826 B2 11/2003 Little et al.  
 6,752,763 B2 \* 6/2004 Erikson ..... 600/459  
 6,814,701 B1 11/2004 Tamura  
 6,875,178 B2 4/2005 Phelps et al.  
 6,932,517 B2 8/2005 Swayze et al.  
 7,169,108 B2 1/2007 Little et al.  
 7,371,218 B2 5/2008 Walston et al.  
 2002/0081871 A1 \* 6/2002 Swayze et al. .... 439/76.1  
 2003/0139664 A1 \* 7/2003 Hunt et al. .... 600/407  
 2003/0171674 A1 \* 9/2003 Jago et al. .... 600/437  
 2004/0002657 A1 \* 1/2004 Marian ..... 600/459  
 2004/0015079 A1 1/2004 Berger et al.  
 2004/0109028 A1 6/2004 Stern et al.  
 2004/0181154 A1 \* 9/2004 Peterson et al. .... 600/459  
 2005/0148878 A1 7/2005 Phelps et al.  
 2005/0192499 A1 9/2005 Lazenby  
 2005/0203391 A1 9/2005 Phelps et al.  
 2005/0203404 A1 9/2005 Freiburger  
 2008/0027322 A1 1/2008 Freiburger  
 2008/0027323 A1 1/2008 Freiburger

FOREIGN PATENT DOCUMENTS

EP 1049407 B1 12/2005  
 WO WO 00/30540 6/2000

\* cited by examiner

FIG. 1

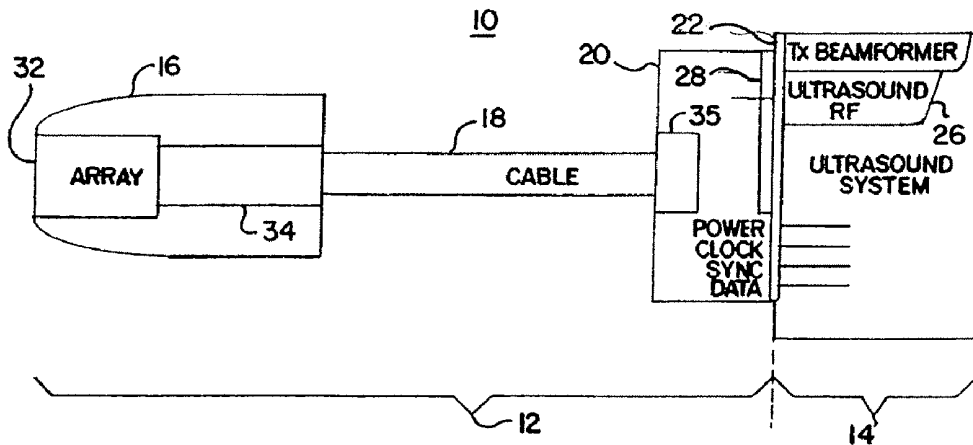
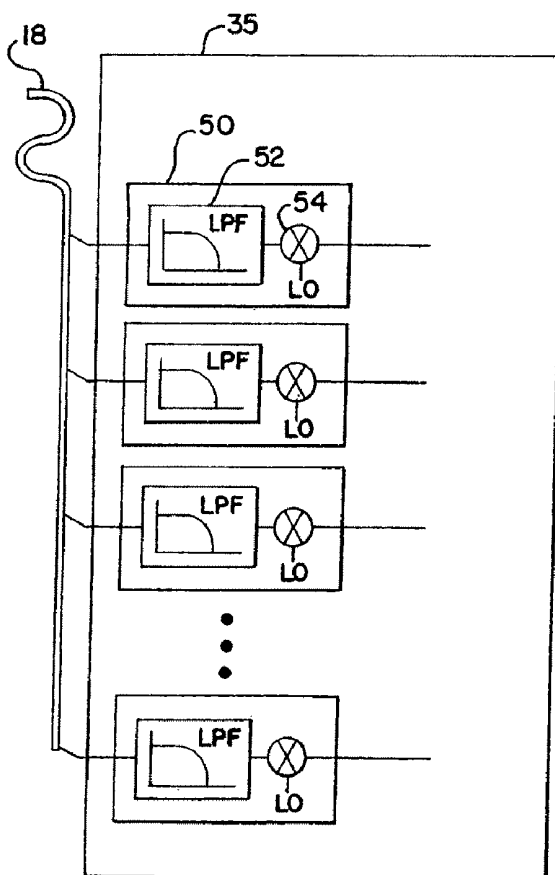
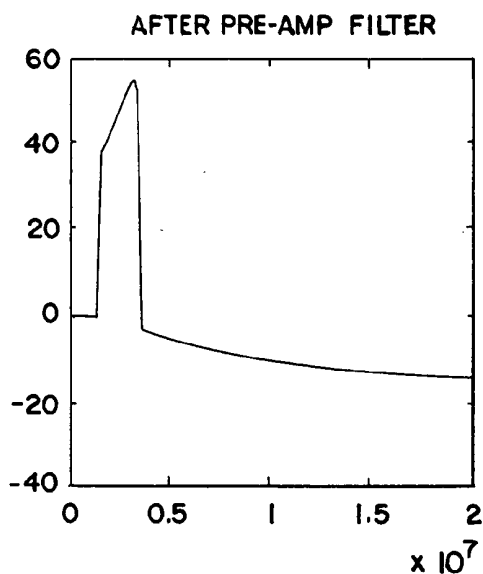

FIG. 2



### FIG. 3A



### FIG. 3B

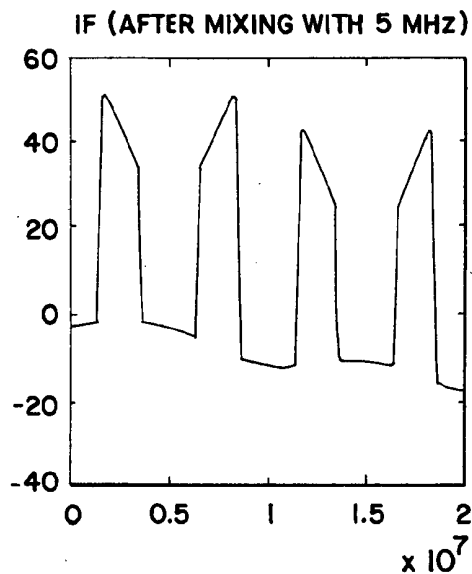

### FIG. 3C

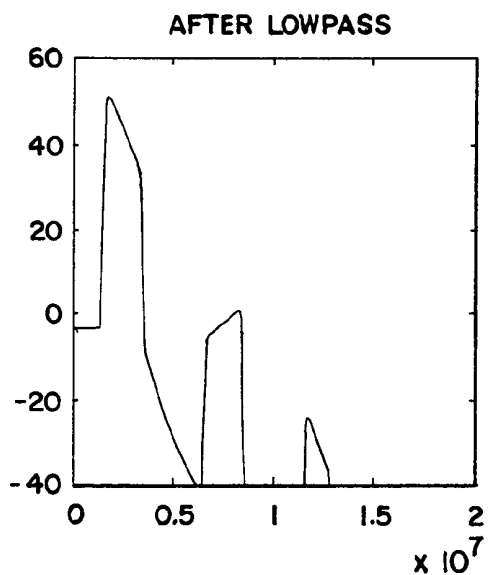

### FIG. 3D

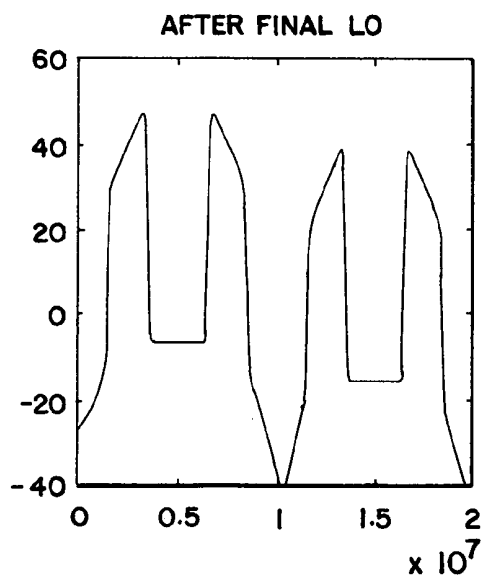

FIG. 4

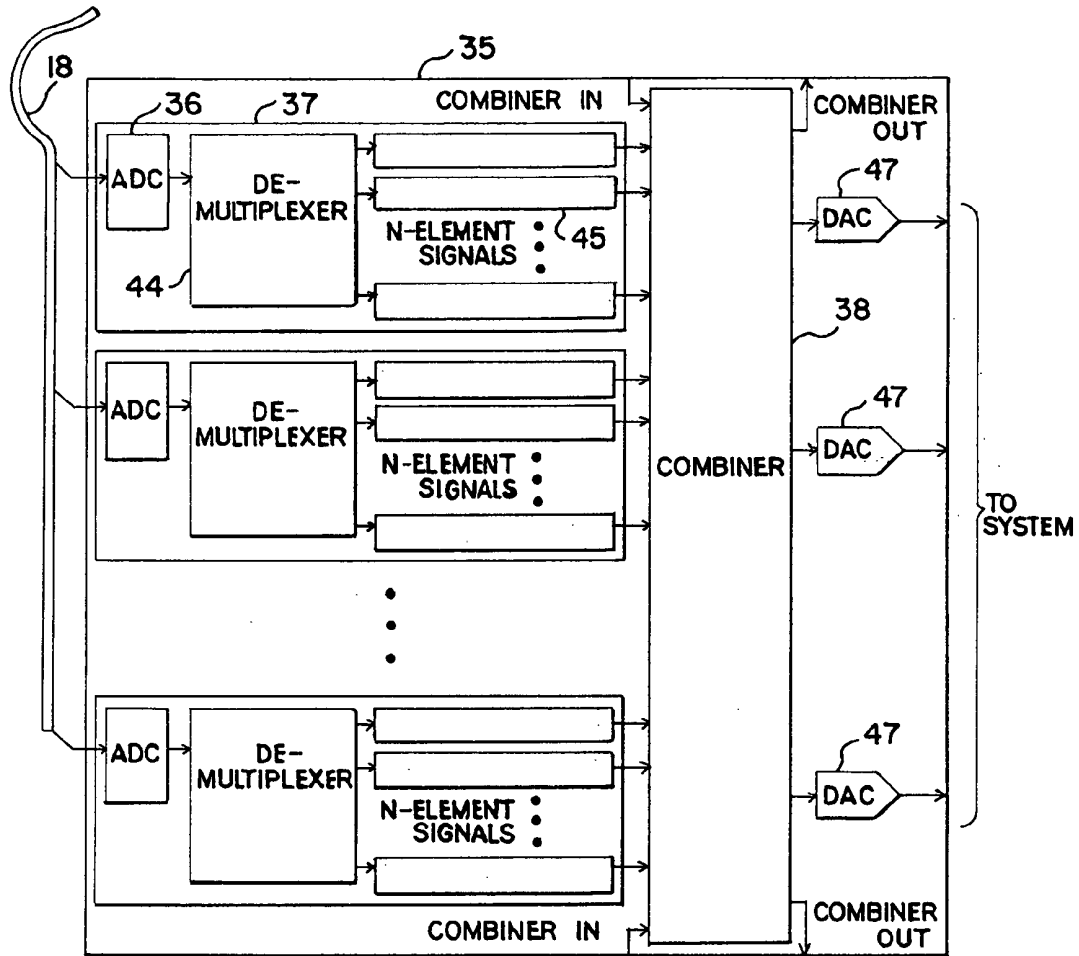
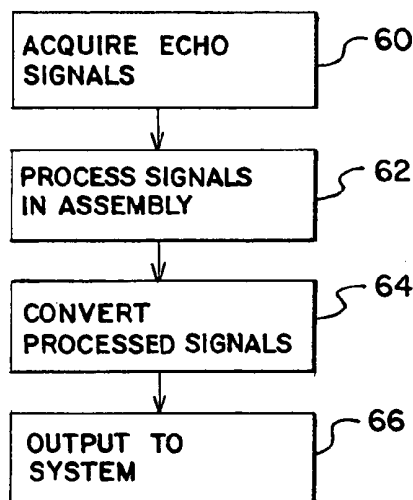

FIG. 5



# ULTRASOUND ADAPTOR METHODS AND SYSTEMS FOR TRANSDUCER AND SYSTEM SEPARATION

## BACKGROUND

The present invention relates to transducer architectures and ultrasound systems. In particular, electronics are positioned in an ultrasound transducer probe assembly.

Medical diagnostic ultrasound systems typically have detachable ultrasound probe assemblies. A transducer array is housed in a hand-held probe. The hand-held probe is connected through a cable to a connector housing. The connector housing electrically and mechanically releasably connects to an ultrasound system. The user can select different ultrasound probes for different examinations and connect the selected probe to the ultrasound imaging system. Using beamformers and other circuitry in the ultrasound imaging system, an image is generated through the transmission and reception of acoustic energy by the connected transducer probe.

Electronics associated with the imaging system have been placed in the ultrasound probe housing. For example, time delays and summers are positioned in a transducer probe to perform partial beamforming from a multidimensional array. The partially beamformed signals (i.e., signals from each beamformed sub-array) are output to the ultrasound imaging system for beamforming. As another example, U.S. Pat. No. 5,590,658 discloses a hand-held probe housing in which the ultrasonic transducers and beam forming circuitry are housed. As another example, U.S. Pat. No. 6,875,178 (U.S. application Ser. No. 10/184,461), the disclosure of which is incorporated herein by reference, discloses integrating a multiplexer and other electronics in the hand-held ultrasound transducer probe housing. Signals from a plurality of transducer elements are time division multiplexed onto a few number of cables for transmission to the ultrasound imaging system. In another ultrasound transducer probe assembly, a controller for a wobbler transducer is positioned in the connector housing for controlling the motor of the wobbler array in the probe housing. As yet another example, switches for selecting an aperture on a 1.5 D array or passive tuning inductors are positioned within a connector housing of a transducer assembly.

## BRIEF SUMMARY

By way of introduction, the preferred embodiments described below include methods and systems for adapting signals from an ultrasound transducer for an ultrasound system. For real time, three-dimensional imaging or other imaging, partial beamforming or other signal processes are performed within an ultrasound transducer assembly. Where the processes result in data incompatible with the ultrasound system, circuitry provided within the transducer assembly converts the data to be compatible with the ultrasound system. For example, sub-array mixing is provided to partially beamform signals from a plurality of transducer elements. The mixers and summers are provided in the transducer probe. The resulting output signals are provided through a cable to a connector housing of the transducer probe assembly. Since the mixers alter the data, such as shifting the data to an intermediate frequency, the output data may be at a frequency different than the frequencies for operation of the receive beamformer. Additional mixers are then provided to convert the intermediate frequency signals to radio frequency signals that may be processed by the receive beamformer. As another example, signals from a plurality of transducer elements are

multiplexed together, such as using time divisional diplexing. Where the received beamformer is not operable to de-multiplex such signals, circuitry within the transducer probe assembly converts the signals by de-multiplexing the data.

Ultrasound systems have a limited number of received beamformer channels. By providing signal processing, conversion, and/or partial beamforming within the transducer probe assembly, the number of elements used may be different than the number of receive beamformer channels provided by the system.

Since the signal processing electronics in the ultrasound transducer probe assembly may output data different than usable by the received beamformer, a full bandwidth of the coaxial cable may be utilized between the probe housing and the connector housing. Optical fibers or other cables may be used as an alternative to coaxial cables. This signaling format between the probe housing and the connector housing is unconstrained by the number and compatibility of receive beamformer channels. Any of different transducer array technologies may be used, including PZT, CMUT or multi-layer PZT. Where a new technology is developed, the ultrasound transducer probe assembly is used to convert signals from the new technology to signals expected by the receive beamformer. By providing some or all of the electronics discussed herein within the connector housing, power dissipation, thermal dissipation and the volume available for electronics may be larger than positioning the electronics within the transducer probe housing. Other, different or none of the above advantages may be provided while using one or more aspects, systems or methods claimed below.

In a first aspect, a method for adapting signals from an ultrasound transducer for an ultrasound system is provided. Signals from a plurality of elements are processed within a transducer assembly. The processed signals are converted to a different form appropriate for the ultrasound system. The conversion is performed in the transducer assembly.

In a second aspect, a transducer assembly for adapting signals from an ultrasound transducer for an ultrasound system is provided. A cable connects with the ultrasound transducer. A connector housing at least partially encloses a detachable connector and a signal processing device. The cable electrically connects elements of the ultrasound transducer to the signal processing device. The detachable connector is operable to connect and disconnect from the ultrasound system. The detachable connector is also operable to output signals responsive to the signal processing device and the ultrasound transducer.

In a third aspect, a method for adapting signals from an ultrasound transducer for an ultrasound system is provided. Signals from a plurality, M of elements of an ultrasound transducer are partially beamformed. The partial beamforming is performed in the transducer assembly. The partially beamformed signals are converted to a different form appropriate for the ultrasound system. The conversion is performed in the transducer assembly. The converted, partially beamformed signals are output to a plurality, N, of beamformer channels of the ultrasound system. N is less than M.

The present invention is defined by the following claims, and nothing in this section should be taken as a limitation on those claims. Further aspects and advantages of the invention are discussed below in conjunction with the preferred embodiments.

## BRIEF DESCRIPTION OF THE DRAWINGS

The components and figures are not necessarily to scale, emphasis instead being placed upon illustrating the principles

of the invention. Moreover, in the figures, like reference numerals designate corresponding parts throughout the different views.

FIG. 1 is a block diagram of a transducer assembly in an ultrasound imaging system in one embodiment;

FIG. 2 is a block diagram of one embodiment of a signal processing device;

FIGS. 3A-D are graphical representations of an example partial beamforming process using sub-array mixing;

FIG. 4 is a block diagram of one embodiment of a signal processing circuit; and

FIG. 5 is a flowchart diagram of one embodiment of a method for adapting signals from an ultrasound transducer for an ultrasound system.

#### DETAILED DESCRIPTION OF THE DRAWINGS AND PRESENTLY PREFERRED EMBODIMENTS

Many of the devices and associated processing within the transducer assembly discussed below may be performed anywhere within the transducer assembly. In one embodiment, some or all of the electronics are positioned within a connector housing where space and power are more readily available as opposed to a transducer probe housing or along a cable. Signals that are incompatible with the receive beamformer of an ultrasound imaging system are converted into compatible signals. For example, many current ultrasound systems are unable to accept signals outside of a certain frequency range, digital signals or multiplexed signals. Electronics within the transducer assembly, such as the connector housing, convert digital signals to analog, multiplexed signals to de-multiplexed signals, or signals at one frequency band shifted to another frequency band. As a result, state of the art circuit technology may be provided within the transducer probe assembly for partial beamforming, compressing or otherwise processing data from a transducer array. These processes may be independent of a form of signals usable by the received beamformer of an old, conventional or incompatible ultrasound system. The number of cables connecting a transducer array to an ultrasound system and the signaling scheme used on the cables may be selected independent of the receive beamformer of the imaging system. Partial beamforming may alter the data in ways that would not be compatible with the receive beamformer. The positioning of signal processing circuitry within the connector housing of the transducer probe assembly, partial beamforming followed by conversion to a compatible format, or other processing of signals within a transducer assembly followed by converting the processed signals to a compatible format may be used independently of each other or in any combination.

FIG. 1 shows one embodiment of a system 10 with a transducer assembly 12 for adapting signals from an ultrasound transducer array 32 for an ultrasound system 14. FIG. 1 shows the transducer assembly 12 connected to the ultrasound system 14. The detachable transducer assembly 12 allows selection of different transducers with different frequency responses or other characteristics for imaging by the ultrasound system 14.

The ultrasound system 14 is a medical diagnostic ultrasound imaging system in one embodiment. In other embodiments, the ultrasound system 14 is a computer, work station or other medical imaging system. For a stand alone ultrasound system, the ultrasound system 14 includes a transmit beamformer 24 and a receive beamformer 26 connected with a connector 22. The transmit beamformer 24 is operable to generate a plurality of relatively delayed and apodized wave-

forms for transmitting acoustic energy along one or more beams at the same time. The electrical signals generated by the transmit beamformer 24 are routed to the connector 22. The connector 22 also electrically connects to the receive beamformer 26. In one embodiment, the connections within the ultrasound system 14 from the connector 22 are permanent and made through one or more switches, such as a transmit and receive switch.

The receive beamformer 26 is an analog or digital receive beamformer. The receive beamformer 26 is configured to receive analog signals at a radio frequency band (e.g., a band centered at 2-10 MHz), but may be configured to receive either analog or digital signals at the same or different frequency bands. In one embodiment, the receive beamformer 26 includes separate beamformers for different imaging modes, such as a separate spectral Doppler beamformer and a B-mode and color-flow mode beamformer. For example, the receive beamformer 26 is a processor on a printed circuit board, ASIC or other device. The beamformer 26 includes a plurality of delays, amplifiers and one or more summers. The electrical signals representing different elements or groups of elements are relatively delayed, apodized and then summed to form samples or signals representing different spatial locations along one or more receive beams. The beamformers 24, 26 are configured to provide a wideband interface, such as a switching matrix with 128, 192 or 384-wire impedance controlled paths from the connector 22 to the beamforming cards or slots on the printed circuit board interconnects. Other switching matrix and number of paths may be provided.

Further processes and associated circuitry are implemented by the ultrasound system 14 for generating an image or for calculating measurements from the receive beamformed information. Different, additional or fewer transmit and receive circuit devices or components may be provided.

The transmit beamformer 24, receive beamformer 26 and connector 22 are at least partially enclosed within a system housing 25. The system housing 25 is plastic, metal, wood, fiberglass, or any other now-known or later-developed material for housing electronics. In one embodiment, the system housing 25 is a workstation or cart-based housing supported on wheels or resting on the floor. In other embodiments, the system housing 25 is a lap top or other portable-sized device, such as a suitcase-sized portable ultrasound system. In yet another embodiment, the system housing 25 is a hand-held ultrasound system, such as a PDA or scope-shaped housing.

The connector 22 is one of any now-known or later-developed mechanical and electrical connectors for detachably connecting and removing the transducer assembly 12. The connector 22 includes grooves, extensions, latches, screws, threaded holes or any other now-known or later-developed mechanical structure for releasably connecting to another device. A plurality of male or female electrical connections for connecting with individual digital traces, such as in a circuit board configuration, or for connecting with coaxial cables is provided. For example, 192 or other number of electrical connections of exposed metallic traces on a circuit board for mating are recessed within the connector 22. In one embodiment, the connector disclosed in U.S. Pat. No. 6,371,918, the disclosure of which is incorporated herein by reference, is used.

The connector 22 mounts to the system housing 25. While one connector 22 is shown, a plurality of different connectors may be provided for connecting to a same type or different types of transducer probe assemblies 12. The connector 22 electrically connects with the receive beamformer 26. In alternative embodiments, the connector 22 is a standard or

custom connection on a PC, digital repeater or other electrical device for locally processing data or for transmitting data for remote processing.

In one embodiment, the connector **22** includes one or more switches, such as a multiplexer, group of transistors or other switching device for switching one or more inputs from the connector **22** to different receive beamformers or different channels of a given receive beamformer **26**. In other embodiments, the switch for switching between receive beamformers or channels is provided by components separate from the connector **22** or is not provided.

The ultrasound transducer assembly **12** includes a transducer probe housing **16**, a cable **18**, and a connector housing **20**. Additional, different or fewer components may be provided. For example, a hand-held system **10** is provided where the transducer probe housing **16** is included as part of the connector housing **20** without the cable **18**. The transducer assembly **12** provides a detachable transducer for connecting and disconnecting from the ultrasound system **14**.

The transducer probe housing **16** is plastic, metal, rubber, combinations thereof or any other now-known or later-developed material for housing a transducer array of elements **32**. In one embodiment, the transducer probe housing **16** is shaped for hand-held use. In other embodiments, the transducer probe housing **16** is shaped for use internal to a patient, such as shaped as an endoscope or catheter. The transducer probe housing **16** at least partially houses an array of elements, such as covering a portion of the array and allowing a face of the array acoustical access for scanning a patient.

The array of elements **32** is an array of piezoelectric, multilayer piezoelectric, capacitive membrane ultrasound transducer or other now-known or later-developed elements for converting between electrical and acoustical energies. One or multidimensional arrays are provided with full or sparse sampling. For example, a 2-dimensional array has M elements (e.g., 1,920 or other number) fully-sampled in a square or rectangular grid positioned on a planar or curved surface. The transducer array **32** includes a flex circuit, signal traces or other structures for electrical interconnection from the elements of the array **32** to other electronics of the probe assembly **12**. For example, the flex circuits are connected to a plurality of coaxial cables in the cable **18** or to electronics within the connector housing **20**.

In an alternative embodiment, the transducer array **32** electrically connects to electrical components **34** within the probe housing **16**. For example, the probe electronics **34** include a multiplexer electrically connected between the plurality of cables of the cable **18** and the transducer elements of the array **32**. The multiplexer is positioned in the transducer probe housing **16** with the array **32**. The multiplexer is operable to multiplex signals from a plurality of elements onto a fewer number of outputs using time division multiplexing. In alternative embodiments, other forms of multiplexing are provided. Preamplifiers or other structures are also included in other embodiments with the multiplexer. For example, the structures disclosed in U.S. Pat. Nos. 6,875,178 and 7,371,218 (U.S. Ser. Nos. 10/184,461 and 10/341,871), the disclosures of which are incorporated herein by reference, are used. For a multidimensional array, signals from every 2, 4, 8 or other number of elements are multiplexed onto a common analog or digital output. A plurality of outputs for different groups of elements is provided.

In another embodiment, the probe electronics **34** include delays, amplifiers and summers for performing beamforming functions for sub-arrays or across the entire array. For example, time based delays and summers are provided for sub-array or partial beamforming. As yet another example,

sub-array mixing is used for partial beamforming. Using mixers (e.g., multipliers), different phase adjustments are applied to signals from different elements. This phase adjustment approximates a delay, but may result in shifting the frequency of the signals to an intermediate frequency. The phase adjustment may also alter the data to be a mirror image in spectral content. The phase adjusted signals for each sub-array are then summed by a summer. U.S. Pat. No. 5,573,001, the disclosure of which is incorporated herein by reference, shows different embodiments for sub-array mixing. The circuits for the sub-array mixing are in the transducer assembly **12**, such as in the probe housing **16**.

In alternative embodiments, the probe electronics **34** are different components for the same or different functions, or the transducer probe housing **16** is provided without the further electronics **34**. Other signal processing using active components may be provided, such as filtering or amplifying.

The cable **18** includes a plurality of coaxial cables connected with the ultrasound transducer array **32**. For example, 64, 128, 192 or other number of coaxial cables are provided for transmitting electrical signals representing acoustic energy received at elements of the array **32**. Each coaxial cable receives information for one element or information representing a plurality of different elements. In alternative embodiments, the cable **18** is a flexible circuit, optical data path, fiber optic, insulated wires or other now-known or later-developed structure. For example, analog-to-digital converters are provided in the transducer probe housing **16**, and digital signals are transmitted along now-known or later-developed digital paths through the cable **18**. The cable **18** electrically connects the ultrasound transducer array **32** to the electronics of the connector housing **20**. Where multiplexing or partial beamforming is provided, fewer cables than elements may be used.

The connector housing **20** is metal, plastic, rubber, combinations thereof or other now-known or later-developed materials for housing or at least partially enclosing a signal processing device **35** and a detachable connector **28**. Additional, different or fewer components may be included within the connector housing **20**. For example, termination resistors or passive tuning circuits connect with each of the cables for providing an impedance match. The transmit path is provided by switches (e.g., multiplexer or transistor) to bypass the signal processing of the receive circuitry and connect to the cable **18**. Alternatively, a portion or all of the transmit beamformer is provided within the transducer assembly **12**. Controllers or other now known or later developed active or passive devices may be provided. As another example, a part or all of the signal processing device **35** is positioned within the probe housing **16** or cable **18** rather than the connector housing **20**. The connector housing **20** is connected at the end of the cable **18**, so that the connector housing **20** is spaced from the ultrasound transducer array **32** and associated probe housing **16**.

The connector housing **20** is shaped to allow detachment and attachment to the housing **25** of the ultrasound system **14**. In one embodiment, now-known connector housings are extended in length away from the connector **28** to accommodate the additional electronics, such as extending by twice the distance used for connectors without electronics. Different changes in dimension may be provided, such as making the connector housing **20** longer, higher, wider or combinations thereof. The connector housing **20** is shaped and sized to include heat sinking, fans and/or active cooling for cooling the enclosed electronics. In alternative embodiments, no additional cooling devices or different now-known or later-developed cooling is provided. In one embodiment, at least

one fan is positioned adjacent to a vent in the connector housing 20. Additionally or alternatively, a rigid thermal connection is provided between the connector housing 20 and the ultrasound system 14 for conducting heat away from the electronics. A forced air connection between the connector housing 20 and the ultrasound system 14 may alternatively be provided for ducting hot air from the connector housing 20 through a fan in the ultrasound system 14 or forcing air from the ultrasound system 14 into the connector housing 20.

The signal processing device 35 is a filter, analog-to-digital converter, digital-to-analog converter, mixer, multiplier, demultiplexer, summer, digital circuit, analog circuit, application specific integrated circuit, general processor, digital signal processor, combinations thereof or other now known or later developed device for actively processing signals from one or more elements of the array 32. In one embodiment, a portion or the entire signal processing device 35 is enclosed within the probe housing 16. For example, the signal processing device 35 is the electronics 34 for partial beamforming, multiplexing or performing other signal processing. In another embodiment, the cable 18 electrically connecting the elements of the ultrasound transducer array 32 to the signal processing device 35 where the signal processing device 35 is enclosed within the connector housing 20. For example, the signal processing device 35 includes circuits or devices for converting signals to a different form appropriate for the receive beamformer 26 of the ultrasound system 14. FIGS. 2 and 4 show two embodiments of the signal processing device 35 for converting processed signals, one embodiment for converting sub-array mixed signals (FIG. 2) and another for converting multiplexed signals (FIG. 4).

As shown in FIG. 2, the signal processing device 35 includes a plurality of mixing circuits 50. Each mixing circuit 50 includes a low pass filter 52 and a multiplier 54, but additional, different or fewer components may be provided. For example, a gain-control device is useful for matching the output signal amplitude with the input of the ultrasound system 20. Such a gain control device may have fixed or time-varying gain. A mixing circuit 50 is provided for each of the sub-arrays. For example, a multi-dimensional transducer array 32 is used for real time three-dimensional imaging. Signals for different groups of elements are mixed with different phasing and summed to form signals for a plurality of different sub-arrays. A mixing circuit 50 is then provided for each of the sub-array signals. The low pass filter 52 comprises a plurality of passive analog components for removing the added signal components at different harmonic frequencies. In alternative embodiments, the low pass filter 52 is an active analog or digital circuit. For example, the mixing circuit 50 or the signal processing circuit 35 includes analog-to-digital or digital-to-analog converters for implementing the sub array mixing from the intermediate frequency back to the radio frequency using digital devices.

An example sub-array mixing scheme is shown in FIG. 3. The graphical representation after preamplification filtering of FIG. 3A represents a signal prior to sub-array mixing. After mixing with a same or different frequency signal, such as a 5 MHz mixing signal for a 2.5 MHz receive signal, a plurality of different signal components are added as shown in FIG. 3B. At 2.5 MHz, the same signal is maintained only at a mirror image. The mixed signals from a plurality of different elements are then summed together. Since the receive beamformer may not function properly in receiving a mirror image signal or a signal with a plurality of added components, the mixing circuit 50 intercepts the partially beamformed, sub-array mixed, intermediate frequency signals and uses filtering and mixing to output signals that are used with a conventional

radio frequency interface of the receive beamformer 26. FIG. 3C shows the intermediate frequency signal after low pass filtering. Since the signal of interest at 2.5 MHz is still a mirror image signal, the multiplier 54 is used as a mixer to convert the intermediate frequency back to the radio frequency as well as repeating the mirror image function. The mixing frequency used by the multiplier 54 is the same frequency as used in the sub-array mixing for partial beamforming. The additional undesired frequency components, such as shown in FIG. 3D after mixing, are removed by an additional low pass filter, such as provided within the ultrasound system 14 or provided as part of the signal processing device 35. The example in FIG. 3 allows the use of a low-pass filter 52 prior to the final mixer 54. Other choices of mixing frequency may require different filtering (e.g. BPF or HPF) before and/or after the final mixer to select the desired component and reject others.

Using sub-array mixing, each of the mixing circuits 50 reverses or converts signals altered from the sub-array mixing to signals usable by the ultrasound system 14. Each mixing circuit 50 outputs the converted signals to the system connector 28 for use by the receive beamformer 26. Since the signals are converted to a different form, the low power sub-array partial beamformer using phase adjustments and summation may be provided within the transducer assembly 12. In alternative embodiments, the multiplier 54 or mixing circuit 50 alter the frequency of signals from a single element to a receive beamformer 26 compatible frequency.

FIG. 4 shows the signal processing device 35 for use with multiplexing, such as time division multiplexing. In the transducer probe housing 16, signals from different groups of elements are multiplexed together for transmission along a fewer number of cables 18 than transducer elements in the array 32. Since conventional ultrasound systems may not process multiplexed signals, the signal processing device 35 converts the signals into a form usable by the receive beamformer 26. As a result, multiplexing is provided within the transducer assembly 12 for reducing the number of cables 18 while still outputting signals to the ultrasound system 14 usable by conventional receive beamformers 26. For example, the signal processing circuitry 35 performs partial beamforming after demultiplexing of signals so that a fewer number of receive beamformer channels 26 may be used with a greater number of elements in the array 32.

The signal processing device 35 is an application specific integrated circuit, digital circuit, analog circuit, general processor, digital signal processor, combinations thereof or other now known or later developed device for processing signals. A channel 37 is provided for each of the multiplexed signal lines from the cable 18. Each channel 37 includes an analog-to-digital converter 36, a demultiplexer 44, and a plurality of signal processors 45, one for each of the demultiplexed signals or signals associated with each element of the array 32. Different, additional or fewer components may be provided for each of the channels 37. In another embodiment, analog demultiplexers 44 are used and analog-to-digital converters 36 are not used. Partial beamforming of analog demultiplexed signals may be used to drive signals into the system directly without DAC 47, or a greater number of low-speed ADCs may be used after analog demultiplexing followed by digital processing and DAC conversion. A greater or lesser number of channels 37 may be provided for the same number of multiplexed signal lines of the cable 18.

The analog-to-digital converters 36 are processors, application-specific integrated circuits, digital components, analog components, amplifiers, transistors, combinations thereof or other now-known or later-developed devices for convert-

ing analog information to digital samples. One analog-to-digital converter 36 is provided for each of the signal lines of the cable 18, or one analog-to-digital converter 36 may be used for multiple of the signal lines. Any number of bits of resolution may be provided by the analog-to-digital converter, such as 4, 8 or 10-bits. Any sampling rate may be used, such as sampling at four times the center frequency of the transducer array 32 on a time-division multiplexed output line (e.g., 96 megasamples per second). In one embodiment, each analog-to-digital converter 36 is a single device or is a package or chip including analog-to-digital converters 36 for 16 to 32 time-division multiplexed channels. At 32 channels per chip, 256 channels of analog-to-digital conversion are provided by 8 devices. Each chip may have 672 pins and be 45 mm on a side with a die size of 12.8 by 12.8 mm. Other size chips and associated analog-to-digital conversion structures may be used. The analog-to-digital converters 36 connect between the ultrasound transducer array 32 and the detachable connector 28. Each of the analog-to-digital converters 36 whether in a same or different chip connects with different ones of the plurality of transducer elements. For example, one analog-to-digital converter 36 connects with one element. As another example, one analog-to-digital converter 36 connects with a group of elements with time-division multiplexed signals output on a same line. Different analog-to-digital converters 36 connect with different elements or groups of elements. To reduce power consumption of a plurality of analog-to-digital converters 36, a slightly lower than rated sampling rate may be used, but a full sampling rate may be provided, such as providing for 10-bit sampling at 120 megasamples per second with a power dissipation of about 50 milliwatts.

The demultiplexers 44 are application-specific integrated circuits, multiplexers or other now-known or later-developed devices for demultiplexing time division or other multiplexed information. The demultiplexers 44 connect with the output of the analog-to-digital converters 36 for providing signals representing specific single or small groups of elements separately. In alternative embodiments, the demultiplexers 44 are positioned prior the analog-to-digital converters 36 or not provided. The signal processors 45 may be used, for example, for filtering, mixing or delaying the signals.

The combiner 38 is an application-specific integrated circuit, transistors, multiplexer, switches, delays, amplifiers, summers, digital circuit, analog circuit, combinations thereof or other now-known or later-developed digital signal processing device. In one embodiment, the combiner 38 together with the signal processors 45 provide partial beamforming, such as where the number of elements of the transducer array 32 is greater than the number of separate electrical connections between the connector 28 and the connector 32 of the ultrasound system 14. The combiner 38 is connected between the analog-to-digital converters 36 and the electrical outputs of the connector 28. Digital data is provided as an input for processing, such as partial beamforming operable to combine data from elements of the transducer array and output the combined data on respective ones of the plurality of electrical outputs of connector 28. For example, data from sub-arrays of elements are combined and output as a single data stream. Separate data streams are output for different elements or sub-arrays. The partial beamformer implemented by the combiner 38 connects with the analog-to-digital converters 36 to combine signals from at least two elements of the transducer array 32. By compressing the data, the number of transducer elements used may be independent of the number of system connections or channels of the ultrasound system 14. Alternatively, the multiplexed signals include previous partial beamforming, so the signal processing device 35 demulti-

plexes without or with further partial beamforming. Demultiplexing may be used free of prior or subsequent partial beamforming in the transducer assembly 12.

In one embodiment, the combiner 38 includes multiple devices and interconnected signal lines to connect multiple combiners 38 for expansion. The interconnected signal lines allow signals from different elements to be combined regardless of the particular combiner 38 connected with the signals. While one input channel 37 is shown for each output of the combiner 38, a different number (e.g., more or less) of outputs than input channels 37 may be provided.

The digital-to-analog converters 47 are processors, application specific integrated circuits, digital components, analog components, amplifiers, transistors, combinations thereof or other now known or later developed devices for converting digital information into analog signals. One digital-to-analog converter 47 is provided for each of the output lines of the combiner 38 and for each of the receive beamformer channels used in any given receive beamformer aperture. Any of now known or later developed coding schemes for the digital-to-analog converter 47 may be used. The digital-to-analog converters 47 output to the connector 28. The output analog signal represents a partially beamformed signal in one embodiment, but may represent a signal from a single element in other embodiments. The signal is output for a single receive beamformer channel of the ultrasound imaging system 14 for complete beamforming of the signals from the various digital-to-analog converters 47. In one embodiment, each digital-to-analog converter 47 is a single device, but a package or chip including a plurality of digital-to-analog converters 47 may be used. In one embodiment, the digital-to-analog converters 47 are included in the same application specific integrated circuit as the combiner 38, but separate devices may be provided.

In the embodiment shown in FIG. 4, the signal processing device 35 is provided at least partially within the connector housing 20. Since analog-to-digital converters 36 are provided within the transducer assembly, the wires of the cable 18 may be matched in length and impedance. The cable 18 is of a known length for every channel, allowing a signal bandwidth in multiplexing rates to be maximized. The electronics allow the sub-arrays to be beamformed using fixed delays, dynamic delays, correlation, frequency or other techniques available for digital processing whether now known or later developed. By combining signals from different elements into different sub-arrays or altering the partial beamforming, different transducer designs may be used with the same or different receive beamformers 26. For example, a two-dimensional array is provided with 1,728 elements. For operation with 192 receive beamformer channels, groups of 3x3 elements are partially beamformed. Since the partial beamforming matches the number of sub-arrays to the number of receive beamformer channels, ultrasound systems 14 with a higher number of receive beamformer channels may use smaller sub-arrays, and systems with a lower number of channels may use larger sub-arrays. Programmable signal processing also allows selection of different shapes of sub-arrays, such as changing or steering using the sub-array shape. The sub-array configuration may be dynamic in size, shape and location as a function of depth. In further embodiments, amplifiers are provided for applying apodization to signals from individual elements prior to partial beamforming or for applying apodization after partial beamforming. Providing programmable sub-arrays also allows a tradeoff between the sizes of the sub-array or partial beamforming and a number of different beams received simultaneously in response to the same transmit event. For example, a receive beamformer 26

with 256 channels may divide the channels in half, with each half receiving the same combination of 128 sub-arrays for forming two parallel receive beams. The focusing applied to the sub-arrays or partial beamforming is a compromise between the two receive beams, independent of the steering direction or based on the steering direction of one of the two receive beams.

The detachable connector **28** electrically connects with the ultrasound transducer array **32** without any detachable connections. Alternatively, one or more detachable connections is provided, such as at the interface between the cable **18** and the probed housing **16**. The connector **28** is releasably connectable and disconnectable with the ultrasound system **14**. The connector **28** includes mechanical and electrical structures corresponding to the mechanical and electrical structures of the connector **22** of the ultrasound system **14**. For example, a plurality of electrical signal lines for connection with exposed traces on a circuit board protrudes from the connector housing **20** for insertion into the connector **22**. In one embodiment, the connector **28** is a connector as disclosed in U.S. Pat. No. 6,371,918. Different connectors may be provided. Latches, extensions, screws, threaded holes or other now-known or later-developed releasable connection structures are provided for mechanically attaching the connectors **28** and **22**. The connectors **28** and **22** are operable to easily detach and attach. Through rotation, latching or other processes, the connectors **22**, **28** are attached or detached in seconds or tens of seconds. Longer time periods may be used for more solid connections or for different connectors.

The connectors **22**, **28** include power, clock, synchronization or other control lines for implementing the digital processing within the connector housing **20** or the transducer assembly **12** in synchronization with a format usable by the ultrasound system **14**. Electrical outputs or connections are provided for each of the outputs or signals representing different elements or groups of elements of the array **32** as processed by the signal processing device **35**. For example, the detachable connector **28** has a plurality N of outputs. N is less than the number of elements of the array **32** in one embodiment, but may be equal or more in other embodiments.

Different signal processing of information from the elements of the array **32** is used in other embodiments. In the embodiment shown in FIG. 4, the analog signals are converted to digital signals, digital partial beamforming is provided and then the partially beamformed signals are converted to analog signals within the transducer assembly. In other embodiments, the analog signals are converted to digital signals within the probe housing **16** and digital communication is provided, such as wireless, fiber optic or other electrical trace from the probe housing **16** to the connector housing **20**. Partial digital beamforming and/or digital-to-analog conversion are performed in the connector housing **20**. While time division multiplexing is discussed above, frequency division multiplexing or other spread spectrum techniques may be used. For example, frequency multiplexed signals are demultiplexed and time delay beamforming is performed within the connector housing **20**. For an example using code division multiplexing, the signals are demultiplexed and a delay and sum beamformer is provided within the connector housing **20**. Any of the signal processes discussed above or other signal processes may be provided, including processing other than partial beamforming or format conversion.

In one embodiment, the signal processing device **35** of the transducer assembly **12** performs a set function. Alternatively, the signal processing device **35** is programmable. For example, different steering angles are programmed for imple-

menting different partial beamforming schemes. A data interface is provided between the ultrasound system **14** and the signal processing device **35**, such as a data interface provided through the connectors **22**, **28**. A clock signal is also provided through the connectors **22**, **28** for beamforming, but an independent clock may be used in other embodiment. By using a same clock signal, the transducer probe **12** is synchronized with the ultrasound system **14**. The connectors **22**, **28** also provide power to the transducer assembly **12**. In other embodiments, a battery or other source of power is provided.

FIG. 5 shows one embodiment of a method for adapting signals from an ultrasound transducer for an ultrasound system. The adaptation is performed within a transducer assembly to convert signals for compatibility with the ultrasound system. For example, the images generated by the ultrasound system may be undesirable, noisy or otherwise unusable due to a difference in the signals within the transducer assembly **12** from a form expected by the ultrasound system. The ultrasound system may be incapable of forming beams without the signals being altered for compatibility. Different signal spaces are provided and are not compatible, such as signals with altered spectral content, analog as opposed to digital or at different frequencies. Translation or conversion hardware is positioned within the transducer assembly, such as along the cable or within a connector housing. The conversion hardware is spaced from the transducer probe in one embodiment, but may be positioned within the transducer probe in other embodiments. While four acts are shown in FIG. 5 for adapting signals from a transducer to a system, different, additional or fewer acts may be provided in other embodiments. The method of FIG. 5 is implemented using the systems discussed above with respect to FIGS. 1 through 4 or other systems.

In act **60**, echo signals are acquired. The echo signals are required at each of a plurality of elements. For example, echo signals are acquired for each element of a two-dimensional array for real time three-dimensional imaging. In alternative embodiments, the echo signals are acquired from sparse sampling of the array or from other sources, such as through digital transmission from a remote transducer.

In act **62**, the signals from a plurality of elements are processed within the transducer assembly. For example, the signals are processed within a transducer probe housing, a connector housing, along a cable spaced away from the probe housing or combinations thereof. Signals processed are from at least one element. In one embodiment, the signals from a plurality of elements of a multidimensional array are processed. Any of various signal processing may be used, such as filtering, remapping, conversion or partial beamforming.

In one embodiment, the signals from a plurality of elements are partially beamformed into a fewer number of processed signals. For example, signals from 1,728 elements are partially beamformed onto 192 signals each representing a different sub-array or sub-aperture of elements. By partially beamforming the signals from a plurality of elements in the transducer assembly, ultrasound imaging systems with a fewer number of receive channels may be used. In one embodiment, the number of elements is two or more times as large as the number of receive beamformer channels. By partially beamforming, signal information from each of the elements is maintained but output along fewer signal lines for use by the receive beamformer. Other ratios may be provided, such as greater than a multiple of 2 or less than a multiple of 2.

In one embodiment, the signal processing is partial beamforming using sub-array mixing. For each sub-aperture, different phase shifts are applied to signals from different elements by mixing with a signal having the same or different

frequency. The signals within the sub-aperture are then combined. The phase shifts act as delays for implementing delay and sum type beamforming. Additional signal processing may be provided, such as conversion of the sub-array mixed partially beamformed signals to a form compatible with or more appropriate for the receive beamformer. In one embodiment, the sub-array mixing is performed within the transducer probe housing, but may be performed elsewhere within the transducer assembly.

In another embodiment, the signals are processed using multiplexing. The signals from a plurality of elements are multiplexed onto a same signal line, such as using time division multiplexing for each of a plurality of sub-apertures. In one embodiment, the multiplexing is performed adjacent to the transducer in the transducer probe housing, but may be performed elsewhere in the transducer assembly. The signals are then demultiplexed elsewhere within the transducer probe assembly, such as within a connector housing. The demultiplexing provides signals for each of the elements. To reduce the number of signals for real time three-dimensional imaging, partial beamforming is then provided on the demultiplexed signals. Partial beamforming is performed in the analog or digital domain.

Other signal processing may be provided. The signal processing alters the data from the elements of the transducer array. The data may be altered to be incompatible in some way with the receive beamformer or desired imaging for some signal processing. For example, the spectral content of the signals is flipped or mirror imaged, the receive beamformer is inoperable to use multiplexed data, or the receive beamformer is inoperable to use digital or analog data.

In act 64, the processed signals are further signal processed by conversion to a different form appropriate for the ultrasound system. The conversion is performed within the transducer assembly, such as within the connector housing that is releasable from the ultrasound system. The conversion may be performed in other locations, such as within the cable 18 or within the probe housing in other embodiments. Any of various conversions may be used, such as analog-to-digital conversion, digital-to-analog conversion, up-converting, down-converting, filtering, multiplexing, demultiplexing, multiplying, summing, subtracting, dividing, or other now known or later developed processes for altering analog or digital data. In one embodiment, partially beamformed signals are converted to a different form appropriate for the ultrasound system. For example, partially beamformed signals are mixed to shift from an intermediate frequency to a radio frequency. Where the beamformer is compatible with input signals within a certain frequency range, the mixing shifts the signals to within the frequency range. The mixing may alternatively or additionally alter the spectral content of the signals. In the time division multiplexing embodiment of FIG. 4, the conversion is demultiplexing and/or conversion of digital signals to analog signals.

In act 66, the converted signals are output. For example, partially beamformed converted signals are output to a plurality of beamformer channels where the number of beamformed channels is less than the number of elements. By performing the partial beamforming and conversion within the transducer assembly, a multidimensional array may be used for scanning a patient while imaging is provided using a conventional ultrasound system with a lesser number of receive channels. As a result, real time three-dimensional imaging is more likely possible. By converting processed signals and outputting the converted signals within the detachable connector housing of a transducer assembly, any advantages associated with processing or transmitting data in

forms different than compatible with the receive beamformer may be used within the transducer assembly. For example, time division multiplexing or sub-array mixing are used prior to conversion and output for minimizing the number of signal lines or cables between the transducer probe and the connector housing.

Other embodiments are disclosed in U.S. Pat. No. 7,998,072(application Ser. No. 10/741,827(Attorney Reference Number 2003 P14534)), the disclosure of which is incorporated herein by reference. Partial beamforming, conversion of data and other signal processing and related structures are shown in yet another configuration in the transducer assembly.

While the invention has been described above by reference to various embodiments, it should be understood that many changes and modifications can be made without departing from the scope of the invention. It is therefore intended that the foregoing detailed description be regarded as illustrative rather than limiting, and that it be understood that it is the following claims, including all equivalents, that are intended to define the spirit and scope of this invention.

We claim:

1. A method for adapting signals from an ultrasound transducer for an ultrasound system, the method comprising:

(a) processing signals from a plurality, M, of elements within a transducer assembly having a transducer connector releasably connectable with the ultrasound system, the ultrasound system comprising a transmit beamformer, a receive beamformer, and a system connector in a system housing, the system housing comprising a cart-based housing resting on wheels, the system connector permanently connected through a transmit and receive switch to the transmit and receive beamformers; and

(b) converting the processed signals to a different form appropriate for the ultrasound system, the conversion being in the transducer assembly;

wherein (a) comprises processing signals for a given range from the plurality, M, of elements of a multi-dimensional array of the elements to a lesser plurality, N, of processed signals;

wherein (a) comprises processing within a transducer probe housing, the transducer probe housing being shaped for handheld use, and wherein (b) comprises converting within a connector housing releasable from the ultrasound system, the converting making signals, from the elements, in the connector housing compatible with the receive beamformer;

further comprising connecting, with a cable, the transducer probe housing with the connector housing, the connector housing at least partially enclosing the transducer connector, the transducer connector releasably connectable with the system connector; and transmitting the signals from the elements to the connector housing.

2. The method of claim 1 wherein (a) comprises partially beamforming signals for each of a plurality of sub-apertures.

3. The method of claim 2 wherein (a) comprises for each sub-aperture:

(a1) applying different phase shifts to signals from different elements; and

(a2) combining the signals.

4. The method of claim 1 wherein (a) comprises partially beamforming demultiplexed signals.

5. The method of claim 1 wherein (b) comprises converting digital signals to analog signals.

6. The method of claim 1 wherein (b) comprises mixing the signals.

7. A transducer assembly for adapting signals from an ultrasound transducer for an ultrasound system, the assembly comprising:

- a transducer probe housing including the ultrasound transducer;
- a cable connected with the ultrasound transducer;
- a connector housing at least partially enclosing a detachable connector and a signal processing device, the cable electrically connecting elements of the ultrasound transducer to the signal processing device, the cable external to the connector housing between the ultrasound transducer and the connector housing, and the detachable connector operable to connect and disconnect from the ultrasound system and operable to output signals responsive to the signal processing device and the ultrasound transducer;

wherein the signal processing device comprises a partial beamformer;

the transducer assembly configured for connection with the ultrasound system comprising a cart-based system, the connection being standardized for the cart-based system such that different transducer assemblies, including the transducer assembly, are connectable with the cart-based system for different examinations, the output signals of the transducer including signals in a plurality of channels for receive beamformation by the cart-based system.

8. The assembly of claim 7 wherein the ultrasound transducer comprises a multidimensional array of M elements and the detachable connector having a plurality N of outputs for the output signals, M being greater than N.

9. The assembly of claim 7 wherein the signal processing device comprises a digital-to-analog converter.

10. The assembly of claim 7 wherein the signal processing device comprises a mixer.

11. The assembly of claim 7 wherein the signal processing device comprises a demultiplexer.

12. The assembly of claim 7 wherein the signal processing device is operable to convert the processed signals to a different form appropriate for the ultrasound system.

13. A method for adapting signals from an ultrasound transducer for an ultrasound system, the method comprising:

- (a) partially beamforming signals from a plurality, M, of elements of the ultrasound transducer, the partial beamforming being performed in a transducer probe housing of a transducer assembly;

(b) converting the partially beamformed signals to a different form appropriate for the ultrasound system, the conversion being performed in a connector housing releasable from the ultrasound system, the connector housing part of the transducer assembly and connected to the transducer probe housing by a cable, the cable compris-

ing at least sixty four coaxial cables external of the connector housing and a probe housing enclosing the elements; and

- (c) outputting the converted, partially beamformed signals to a plurality, N, of beamformer channels of the ultrasound system, N being less than M, the ultrasound system comprising a cart-based system having a receive beamformer for receiving the partially beamformed signals on the beamformer channels.

14. The method of claim 13 wherein (a) comprises sub-array mixing and (b) comprises mixing to a frequency of the beamformer channels.

15. The method of claim 13 further comprising:

- (d) multiplexing the signals from the plurality of elements adjacent a transducer probe; and

- (e) demultiplexing the signals within the connector housing;

wherein (b) comprises converting digital signals to analog signals.

16. The method of claim 13 wherein (b) and (c) are performed with at least one signal processing device in the connector housing of the transducer assembly.

17. The method of claim 13 wherein (a) comprises partially beamforming from M signals to N signals, M being at least a multiple of two of N.

18. The method of claim 13 wherein (a) comprises partially beamforming for at least two simultaneously received beams.

19. A method for adapting signals from an ultrasound transducer for an ultrasound system, the method comprising:

- (a) processing signals from a plurality of elements within a transducer housing; and

(b) further processing the signals sent from the transducer housing to a detachable connector within a detachable connector housing, the detachable connector housing spaced from the transducer housing by an external cable, the transducer housing, external cable, and detachable connector housing comprising a transducer assembly for connection to the ultrasound system, the ultrasound system being cart-based and connectable to different transducer assemblies, including the transducer assembly, for receiving data in a standard format, the signals received in the detachable connector housing resulting from the processing of (a) resulting in signals incompatible with the standard format;

wherein (b) comprises one of:

- (b1) digital-to-analog converting of the signals; and
- (b2) mixing the signals.

20. The method of claim 19 wherein (b) comprises converting the processed signals of (a) to a different form appropriate for the ultrasound system.

21. The method of claim 19 wherein (a) comprises partially beamforming signals for each of a plurality of sub-apertures.

\* \* \* \* \*

专利名称(译)	用于换能器和系统分离的超声适配器方法和系统		
公开(公告)号	<a href="#">US8257262</a>	公开(公告)日	2012-09-04
申请号	US10/741538	申请日	2003-12-19
[标]申请(专利权)人(译)	美国西门子医疗解决公司		
申请(专利权)人(译)	西门子医疗解决方案USA, INC.		
当前申请(专利权)人(译)	西门子医疗解决方案USA, INC.		
[标]发明人	PETERSEN DAVID A PHELPS ROBERT N LAZENBY JOHN C		
发明人	PETERSEN, DAVID A. PHELPS, ROBERT N. LAZENBY, JOHN C.		
IPC分类号	A61B8/00 G01S7/52 G01S15/89		
CPC分类号	A61B8/4438 G01S7/52034 G01S7/5208 G01S15/8927 A61B8/4472 G01S15/8925 G01S15/8993		
其他公开文献	US20050148873A1		
外部链接	<a href="#">Espacenet</a> <a href="#">USPTO</a>		

摘要(译)

提供了用于使来自超声换能器的信号适用于超声系统的方法和系统。在换能器组件中的信号处理输出与超声系统不兼容的数据的情况下，换能器组件内提供的电路将数据转换成与超声系统兼容。例如，子阵列混合被提供给来自多个换能器元件的部分波束形成信号。来自多个子阵列的所得输出信号通过电缆提供到换能器探头组件的连接器壳体。由于混频器改变数据，例如将数据移位到中频，输出数据的频率可能不同于操作频率。接收波束形成器。然后提供附加的混频器以将中频信号转换成可由超声系统接收的波束形成器处理的射频信号。作为另一个例子，来自多个换能器元件的信号被多路复用在一起。在接收波束形成器不可操作以对这些信号进行解复用的情况下，换能器探头组件内的电路通过解复用数据来转换信号以进行波束成形。超声系统具有有限数量的接收波束形成器通道。通过在换能器探头组件内提供信号处理，转换和/或部分波束形成，所使用的元件的数量可以与由所提供的接收的波束形成器通道的数量不同。系统。

