



US 20060293595A1

(19) **United States**

(12) **Patent Application Publication**

Clark et al.

(10) **Pub. No.: US 2006/0293595 A1**

(43) **Pub. Date: Dec. 28, 2006**

(54) **SYSTEM AND METHOD FOR ULTRASOUND PULSE SHAPING AND OUTPUT POWER ADJUSTMENT USING MULTIPLE DRIVE PULSES**

Publication Classification

(51) **Int. Cl.**
A61B 8/00 (2006.01)
(52) **U.S. Cl.** **600/437**

(76) Inventors: **David W. Clark**, BRIARCLIFF MANOR, NY (US); **David S. Sherrill**, Westford, MA (US)

(57) **ABSTRACT**

The present invention provides a system and method for ultrasound pulse shaping and output power adjustment using multiple drive pulses. The multiple drive pulses are width modulated to provide the required output signal power and wave-shape characteristics. Using multiple width-modulated pulses provides control over power output that is capable of being varied much more rapidly than using a conventional voltage modulated drive pulse. Additionally, the multiple drive pulses provide better control over unwanted harmonics than does a single drive pulse. These two advantages allow multiple width modulated pulses to increase the capabilities in ultrasonic imaging devices, thereby, allowing for rapid switching between imaging techniques having widely disparate power requirements so that composite diagnostic images may be constructed combining the diagnostic benefits the various imaging techniques have to offer.

Correspondence Address:
PHILIPS INTELLECTUAL PROPERTY & STANDARDS
P.O. BOX 3001
BRIARCLIFF MANOR, NY 10510 (US)

(21) Appl. No.: **10/569,252**

(22) PCT Filed: **Aug. 18, 2004**

(86) PCT No.: **PCT/IB04/51487**

Related U.S. Application Data

(60) Provisional application No. 60/498,000, filed on Aug. 26, 2003.

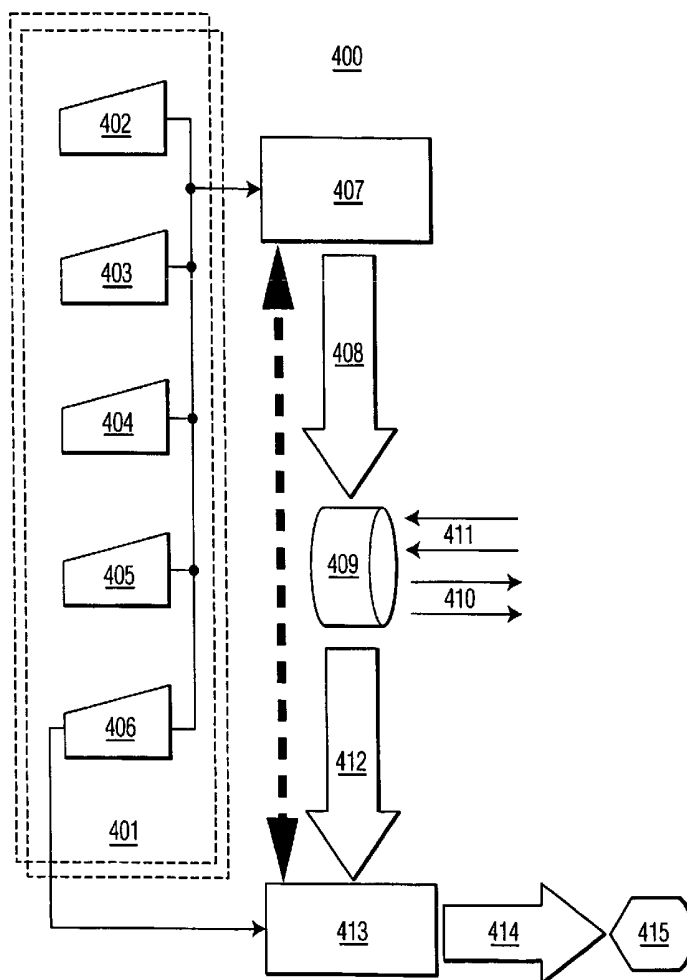

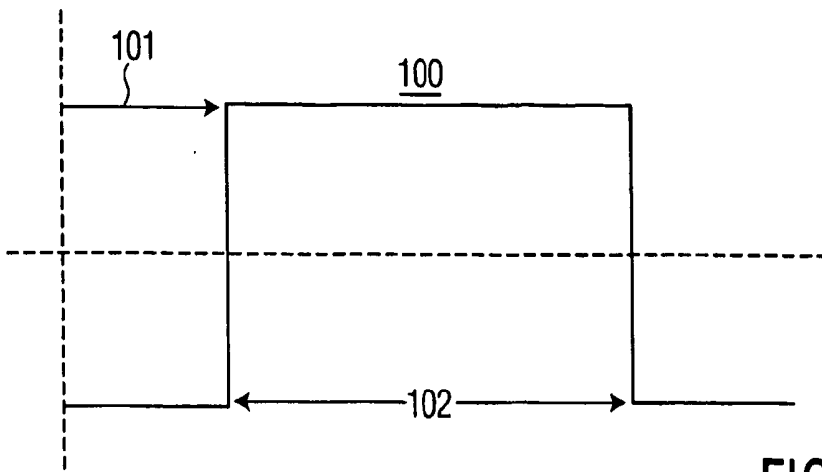

FIG. 1
PRIOR ART

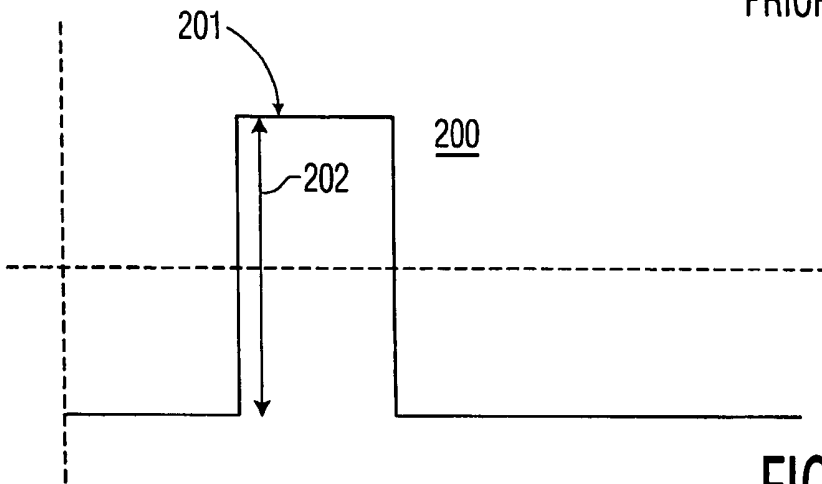

FIG. 2
PRIOR ART

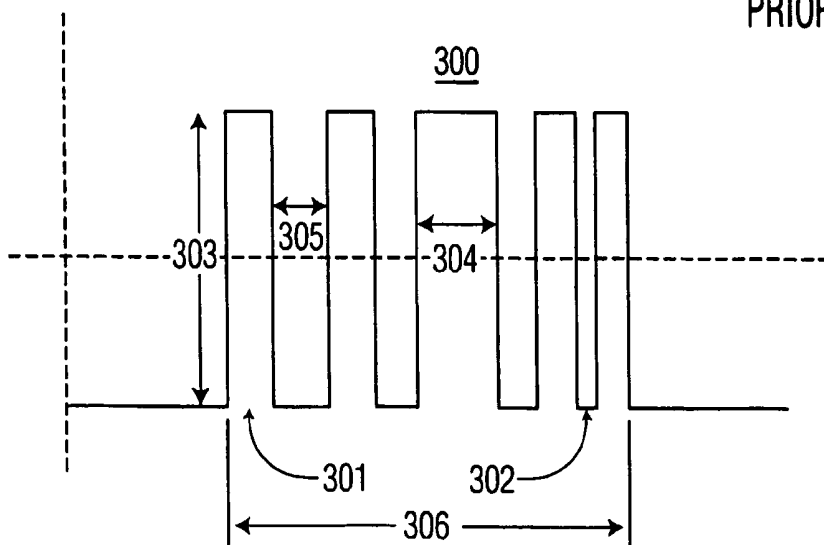

FIG. 3

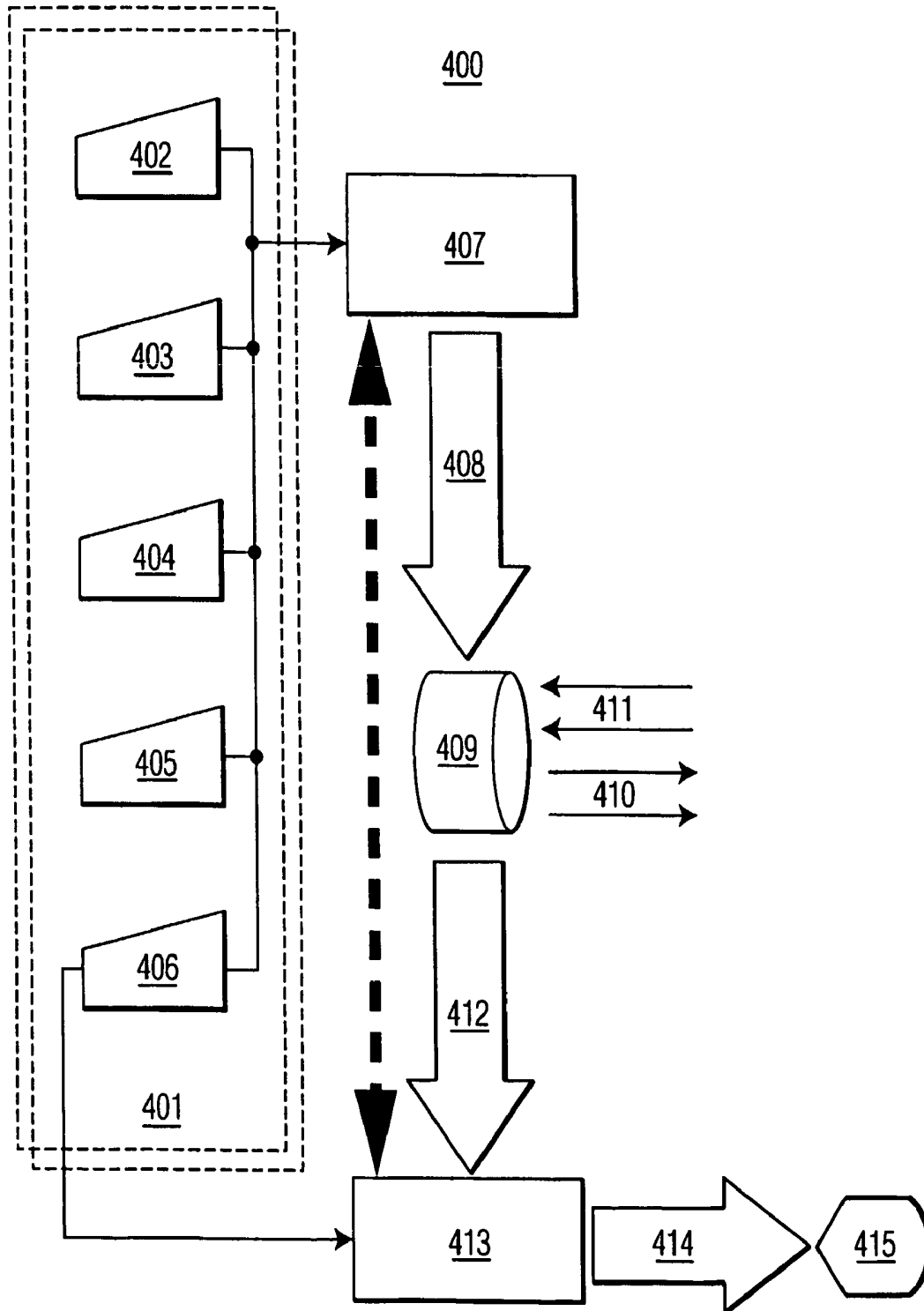

FIG. 4

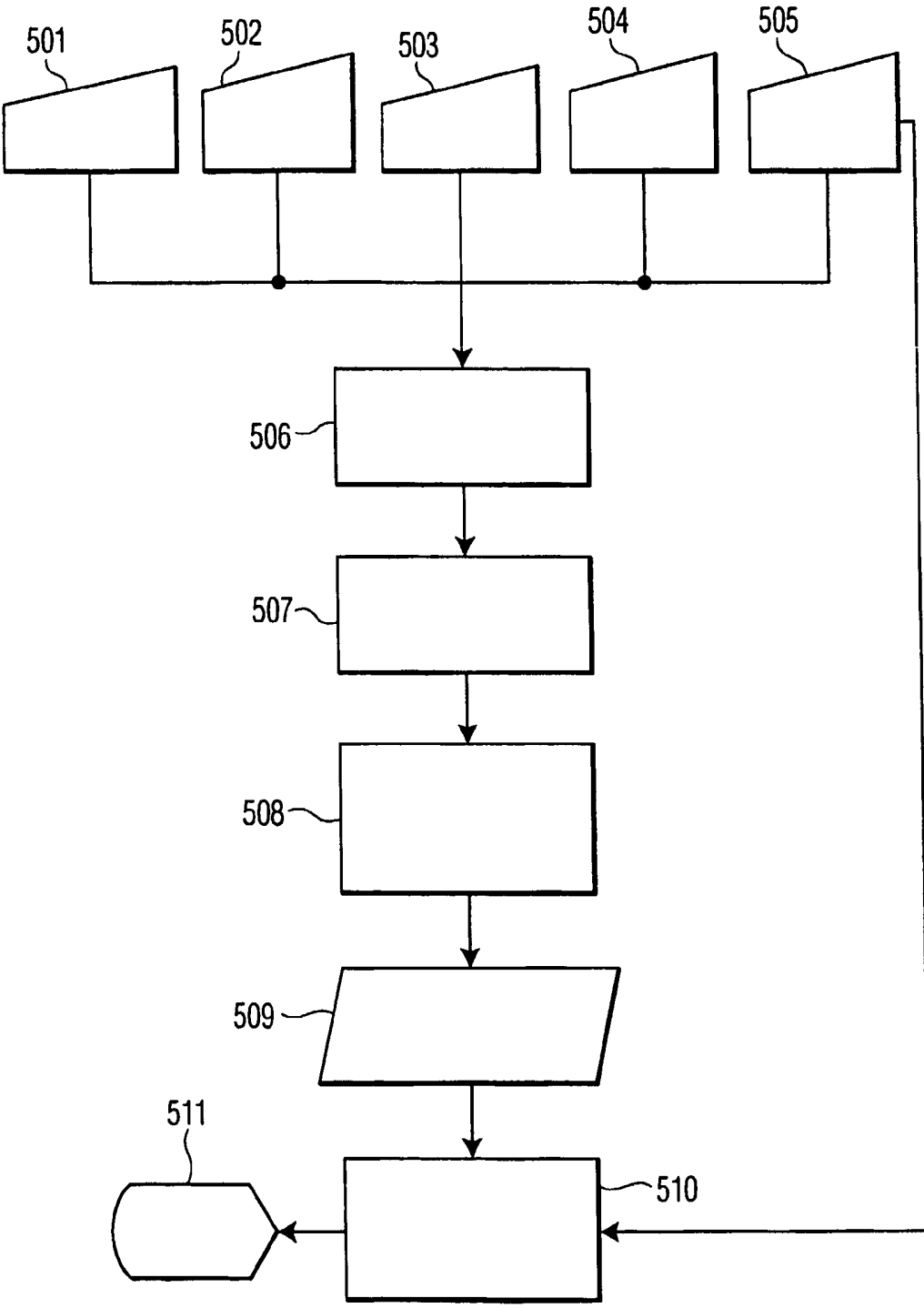

FIG. 5

**SYSTEM AND METHOD FOR ULTRASOUND
PULSE SHAPING AND OUTPUT POWER
ADJUSTMENT USING MULTIPLE DRIVE PULSES**

[0001] The present invention relates to acoustic waveform generation and specifically to ultrasound pulse shaping using multiple drive pulses.

[0002] Ultrasound imaging systems commonly in use generate and transmit ultrasound signals to map internal tissue topography, vascular fluid flow rates, and abnormalities. The systems typically incorporate several methods, or modes, of imaging, i.e. Brightness Mode (B-Mode), Harmonic, Spectral Doppler, and Color Flow.

[0003] Each imaging method has its characteristic uses and limitations. B-Mode imaging is typically used to image a “snapshot” of internal tissue and organs with high spatial resolution. Generally to achieve this degree of spatial resolution, short-duration ultrasound pulses are advantageous as are lower frequencies—lower frequency ultrasound having better penetration.

[0004] Color Flow imaging is primarily used to measure blood flow rates and detect abnormal and destructive turbulent flows within the cardiovascular system. Color Flow images are usually overlaid on to a B-Mode structural snapshot. However, the ultrasound properties necessary for proper Color Flow imaging differ from those used in B-Mode. Low ultrasound pulse repetition rates are desirable for slow-flowing veins, but for the faster flows found in the arteries and heart, higher ultrasound pulse repetition rates are necessary to properly avoid aliasing errors. The sensitivity necessary for Color Flow imaging requires higher ultrasound frequencies than commonly used for the deeper penetrating B-Mode scans. Additionally, Color Flow imaging uses higher-intensity power than B-Mode.

[0005] Harmonic imaging uses the harmonic frequencies produced when a transmitted fundamental frequency is reflected by tissues and other internal structures. Proper Harmonic imaging, thus, requires transmission of ultrasound fundamental frequencies without the associated harmonics, which would be confused with the reflected harmonics. Harmonic imaging makes use of narrowly tuned frequencies achievable through waveform shaping as disclosed in U.S. Pat. No. 5,833,614 “Ultrasonic Imaging Method and Apparatus for Generating Pulse Width Modulated Waveforms with Reduced Harmonic Response” issued to Dodd et al. and incorporated herein by reference in its entirety.

[0006] In all of these imaging methods, it is also desirable to control the power output of the emitted ultrasound pulse. Power output is reduced when imaging delicate tissues such as fetal tissue or to prevent over-heating of the transducer and patient-contact area thus preventing burns to the patient and damage to the ultrasound transducer. One method for controlling power output commonly in use consists of systems to regulate voltage, either automatically or manually, to the ultrasound transducer. However, this power output control method has a relatively slow response time—on the order of hundreds of milliseconds—and may compromise image quality, therefore, voltage modulation is not appropriate in situations where the power level needs to be rapidly varied without loss of image quality, as in the case of Color Flow/B-Mode combination scans.

[0007] An object of the present invention is to provide a system and method for controlling power output having faster response time than obtained with conventional voltage modulation method.

[0008] An additional object of the present invention is to provide a system and method of shaping the output waveform in order to reduce harmonics-induced transducer heating and provide a more versatile imaging system.

[0009] Another object of the present invention is to provide a system and method of shaping the output waveform allowing power output characterization as required for medical-use certifications that is less complex and time consuming than needed by prior art single pulse width modulation.

[0010] The present invention provides a system and method for ultrasound pulse shaping and output power adjustment using multiple Pulse Width Modulated drive pulses. Generally, a drive pulse is a square wave characterized by a duration, amplitude and frequency. These drive pulse characteristics directly affect the shape—frequency, amplitude, waveform, etc.—of the output signal. Thus, by varying the input pulse widths, the output signal can be shaped to meet the needs of most any situation.

[0011] The present invention uses multiple full amplitude drive pulses of varying durations and frequencies to create a desired output signal.

[0012] These and other features, aspects, and advantages of the present invention will become better understood with regard to the following description, appended claims, and accompanying drawings wherein:

[0013] **FIG. 1** is a graphical representation of a typical drive pulse;

[0014] **FIG. 2** is a graphical representation of a prior art pulse width modulation of the drive pulse of **FIG. 1**;

[0015] **FIG. 3** is a graphical representation of a pulse width modulation of the drive pulse of **FIG. 1** in accordance with an embodiment of the present invention;

[0016] **FIG. 4** is a schematic representation of an ultrasound imaging system in accordance with the present invention; and

[0017] **FIG. 5** is a procedural representation of the ultrasound imaging system of **FIG. 4** in accordance with the present invention.

[0018] With reference to **FIGS. 1, 2** and **3**, a typical drive pulse **100** has a duration **102** and amplitude (power) **101** approximately equal to the desired output signal; meaning that if a lower power output signal is desired, the amplitude **101** of the drive pulse **100** would simply be decreased, resulting in a lower amplitude output signal. This method works fine when rapid amplitude fluctuations of the output signal are not required. However, as previously mentioned amplitude modulation is slow (~200 ms).

[0019] Pulse Width Modulation (PWM) **200** solves this speed problem. The PWM method can switch on and off at a rate of mere microseconds—easily capable of meeting the rapid switching requirements for accurate Color Flow/B-Mode combination scans. PWM **200** relies on variable duration drive pulses **201** to achieve a desired power level from the output signal. The amplitude **202** of the drive pulse

201 remains at a constant value while the duration (or width) **201** is varied. Thus over the duration of the output signal, the total power averages out to less than full power. However, this technique creates some new problems. With this method, increased harmonics are produced.

[0020] The increased harmonics actually have two harmful effects. First, output signal harmonics direct power towards unusable frequencies and away from the fundamental frequency, increasing the overall energy needed to be transmitted to the patient in order to achieve a proper ultrasonic image. Second, in Harmonic Imaging, output signal harmonics interfere with the ultrasound imaging system's ability to detect the harmonics produced by the reflection of the output fundamental frequency by the internal tissues and structures of the patient. Additionally, ultrasound devices must be certified for use as medical devices; this certification requires that an output characterization be provided. Generally, in Voltage modulation, this characterization procedure is simple and straightforward, however in PWM systems, the procedure is more complex and time consuming since all possible input pulse widths need to be individually tested and characterized.

[0021] The method of the present invention entails multi-Pulse Width Modulation (m-PWM) **300**. This method solves both the slow amplitude modulation rate issue and the production of output signal harmonics. In m-PWM, as shown by **FIG. 3**, multiple pulses **301** are generated each having constant amplitude **303** and a variable duration **304**. These multiple pulses **301** are separated by pauses **302**—also having variable durations **305**. The group of pulses **301** and pauses **302** has a total duration **306** approximately equal to the actual duration of the output signal, but a reduced total power. The output signal produced with m-PWM would also have a significantly reduced harmonic output. As in the single PWM method, m-PWM can efficiently be switched on and off very rapidly. Additionally, by considering the band limiting effects of the pulsing electronics, the transmission line and the transducer itself, pulses can be chosen such that the acoustic pulse produced is substantially the same as an acoustic pulse produced using voltage modulation. Consequently, the spectral characteristics of the pulse are substantially the same as the voltage modulated pulse, and output characterization is no more complicated than for voltage modulation.

[0022] An embodiment of the present invention, as shown in **FIG. 4**, is a medical diagnostic imaging system **400**, which incorporates the m-PWM method according to the present invention. In the present embodiment, the medical diagnostic imaging system **400** provides the user with an interface for specifying particular output signal characteristics **401** such as frequency **402**, pulse duration **403**, waveform **404**, i.e. Sawtooth, Square, Sinusoidal, etc., output power **405**, and imaging mode **406**, i.e. B-Mode, Harmonic, Spectral Doppler, and Color Flow. The imaging mode **406** will also be used by a signal processor **413** to select the proper method for use in processing the return signal **412**. The output signal characteristics **401** are forwarded to the signal generator **407**. The signal generator **407** applies the specified output signal characteristics **401** to internal algorithms to produce a drive pulse train **408**, which, when applied to the ultrasound transducer **409**, will result in an output signal **410** having substantially similar characteristics as the user specified characteristics **401**. The Signal genera-

tor may either employ a dedicated processor or utilize the signal processor **413** for executing the internal algorithms.

[0023] The output signal **410**, emitted by the ultrasound transducer **409**, impinges on and reflects off of various corporeal structures (not shown) resulting in a return signal **411**. The return signal **411** is detected by an ultrasound receiver, which may either be an element and function of the ultrasound transducer **409** or an entirely separate unit. The return signal data **412** is transferred to the signal processor **413**, which processes the return signal data **412** and produces image data **414**, which are then transferred to a display apparatus **415**. The display apparatus **415**, may be any of the following: video display, printer, etc. additionally the display apparatus **415** may instead be replaced or supplemented by a data storage device, i.e. RAM, magnetic media, optical media, etc.

[0024] Referring to **FIG. 5**, an embodiment of the present invention begins with steps **501-505**, in which the operator selects various options to set output signal characteristics—step **501** sets Frequency, step **502** sets Pulse Duration, step **503** sets Waveform, step **504** sets Output Power and step **505** sets Imaging Mode. Collectively, the output signal characteristics are forwarded to a processor, which subsequently performs step **506**. In step **506**, the processor uses the settings from steps **501-505** to determine the required drive pulse train characteristics that will yield an output ultrasound signal having the characteristics set in steps **501-505**. Step **507** generates a drive pulse train having the characteristics determined in step **506** and applies the drive pulse train to an ultrasound transducer. Subsequently, step **508** transmits an output ultrasound signal directed towards a body region to be imaged. The transmitted output ultrasound signal is reflected by various tissues and body structures and the resulting imaging signal is detected in step **509**. The process continues with step **510**, in which the detected imaging signal is processed and analyzed based on the Imaging Mode setting of step **505**. The operation ends with step **511**, where the processed and analyzed image signal of step **510** is displayed in a user-interpretable manner, preferably on a video display as a graphical representation of the bodily region being imaged.

[0025] The described embodiments of the present invention are intended to be illustrative rather than restrictive, and are not intended to represent every embodiment of the present invention. Various modifications and variations can be made without departing from the spirit or scope of the invention as set forth in the following claims both literally and in equivalents recognized in law.

1. A method for controlling the output power of a signal produced by an ultrasound transducer, comprising the steps of:

producing an input drive pulse train consisting of at least two drive pulses having a fixed amplitude separated by a pause, wherein each of said at least two drive pulses and said pause have adjustable durations;

determining a value for said adjustable durations; and

providing a transducer configured to accept said input drive pulse train and emit an ultrasonic output signal from said input drive pulse train, wherein characteristics of said ultrasonic output signal are determined by characteristics of said input drive pulse train.

2. A method as in claim 1, wherein each of said adjustable durations may have different values.

3. A method as in claim 1, wherein said input pulse train is generated by a signal generator configured to determine said durations necessary to produce said ultrasonic output signal.

4. A method as in claim 1, wherein said drive pulses produced by said signal generator is of a type selected from the group consisting of: Sawtooth, Square and Sinusoidal.

5. A method as in claim 1, wherein said durations are adjusted according to values determined by said signal generator such that said ultrasound transducer produces said ultrasonic output signal having an overall reduced output power.

6. A method as in claim 1, wherein said durations are adjusted according to values determined by said signal generator such that said ultrasound transducer produces said ultrasonic output signal substantially free of harmonic frequencies.

7. A method as in claim 1, wherein said method is performed by a medical diagnostic system.

8. A method as in claim 1, further comprising the step of providing a plurality of imaging modes selected from the group consisting of: B-Mode, Color Flow, Harmonic and Spectral Doppler, said plurality of imaging modes are performed substantially simultaneously by rapidly repeating a scan line for each of said plurality of imaging modes before proceeding to a subsequent scan line.

9. An ultrasound imaging system with controllable output power, comprising:

a signal generator for generating an input drive pulse train, wherein said drive pulse train is comprised of at least two drive pulses having fixed amplitudes and adjustable pulse durations;

a transducer configured to accept said input drive pulse train and emit an ultrasonic output signal from said input drive pulse train, wherein characteristics of said ultrasonic output signal are determined by characteristics of said input drive pulse train;

a user interface configured to allow a user to adjust output signal values for said ultrasonic output signal; and

a processor configured for calculating and setting drive pulse values for said input drive pulse train characteristics, wherein said drive pulse values are calculated by said processor to produce said ultrasonic output signal having said user-adjusted output signal values.

10. The ultrasound imaging system as in claim 9, wherein said signal generator is configured to generate Sawtooth, Square, and Sinusoidal waveforms, having frequencies in the range from 20 KHz to 100 Mhz.

11. The ultrasound imaging system as in claim 9, wherein said input drive pulse durations are adjusted such that said ultrasound transducer generates said ultrasonic output signal having an overall reduced output power.

12. The ultrasound imaging system as in claim 9, wherein said input drive pulse durations are adjusted such that said

ultrasound transducer generates said ultrasonic output signal substantially free of harmonic frequencies.

13. The ultrasound imaging system as in claim 9, wherein said processor is additionally configured to analyze reflected ultrasonic signals and produce a user-interpretable representation of the reflected ultrasonic signals.

14. The ultrasound imaging system as in claim 9, wherein said system is configured to provide a plurality of imaging modes selected from the group consisting of: B-Mode, Color Flow, Harmonic and Spectral Doppler, said plurality of imaging modes are performed substantially simultaneously by rapidly repeating a scan line for each of said plurality of imaging modes before proceeding to a subsequent scan line.

15. A system for controlling the output power of a signal produced by an ultrasound transducer, comprising:

means for producing an input drive pulse train consisting of at least two drive pulses having a fixed amplitude separated by a pause, wherein each of said at least two drive pulses and said pause have adjustable durations;

means for determining a value for said adjustable durations; and

means for providing a transducer configured to accept said input drive pulse train and emit an ultrasonic output signal from said input drive pulse train, wherein characteristics of said ultrasonic output signal are determined by characteristics of said input drive pulse train.

16. A system as in claim 15, wherein each of said adjustable durations may have different values.

17. A system as in claim 15, wherein said input pulse train is generated by a signal generator configured to determine said durations necessary to produce said ultrasonic output signal.

18. A system as in claim 15, wherein said drive pulses produced by said signal generator is of a type selected from the group consisting of: Sawtooth, Square and Sinusoidal.

19. A system as in claim 15, wherein said durations are adjusted according to values determined by said signal generator such that said ultrasound transducer produces said ultrasonic output signal having an overall reduced output power.

20. A system as in claim 15, wherein said durations are adjusted according to values determined by said signal generator such that said ultrasound transducer produces said ultrasonic output signal substantially free of harmonic frequencies.

21. A system as in claim 15, wherein said system is a medical diagnostic system.

22. A system as in claim 15, further comprising a means for providing a plurality of imaging modes selected from the group consisting of: B-Mode, Color Flow, Harmonic and Spectral Doppler, said plurality of imaging modes are performed substantially simultaneously by rapidly repeating a scan line for each of said plurality of imaging modes before proceeding to a subsequent scan line.

* * * * *

专利名称(译)	用于使用多个驱动脉冲的超声脉冲整形和输出功率调节的系统和方法		
公开(公告)号	US20060293595A1	公开(公告)日	2006-12-28
申请号	US10/569252	申请日	2004-08-18
[标]申请(专利权)人(译)	CLARK DAVID W 谢里尔戴维家		
申请(专利权)人(译)	CLARK DAVID W 谢里尔戴维家		
当前申请(专利权)人(译)	皇家飞利浦电子N.V.		
[标]发明人	CLARK DAVID W SHERRILL DAVID S		
发明人	CLARK, DAVID W. SHERRILL, DAVID S.		
IPC分类号	A61B8/00 G01S7/52 G01S7/524 G01S15/10 G10K11/34		
CPC分类号	G01S7/52046 G01S7/52085 G01S7/5202 G10K11/34 G01S15/105		
优先权	60/498000 2003-08-26 US		
外部链接	Espacenet USPTO		

摘要(译)

本发明提供了一种使用多个驱动脉冲进行超声脉冲整形和输出功率调节的系统和方法。多个驱动脉冲被宽度调制以提供所需的输出信号功率和波形特征。使用多个宽度调制脉冲提供对功率输出的控制，其能够比使用传统的电压调制驱动脉冲更快地变化。此外，与单个驱动脉冲相比，多个驱动脉冲可以更好地控制不需要的谐波。这两个优点允许多个宽度调制脉冲以增加超声成像设备的能力，从而允许在具有广泛不同的功率要求的成像技术之间快速切换，从而可以结合各种成像技术必须提供的诊断益处来构造复合诊断图像。

