



US 20050096554A1

(19) **United States**
 (12) **Patent Application Publication** (10) **Pub. No.: US 2005/0096554 A1**
Dudik et al. (43) **Pub. Date: May 5, 2005**

(54) **ACOUSTIC MEDICAL SENSOR FOR ULTRASOUND IMAGING**

Publication Classification

(76) Inventors: **Evan M. Dudik**, Vancouver, WA (US);
Ron Schutz, Portland, OR (US);
William A. Beck JR., Maple Valley, WA (US);
Dana Reinisch, Portland, OR (US);
Laurence A. Daane, Portland, OR (US);
Scott S. Corbett III, Portland, OR (US);
Joshua K. Hoyt, Portland, OR (US);
Eric Park, Portland, OR (US);
Doug Cooke, Portland, OR (US)

(51) **Int. Cl.⁷** **A61B 5/02**
 (52) **U.S. Cl.** **600/500**

(57) **ABSTRACT**

A finger mounted acoustic sensor. Various embodiments of the finger mounted acoustic sensors include sensors mounted within a casing designed to fit between fingers. The sensor may be rotated with respect to the casing. Other embodiments include mounting tubes for wearing on a finger. Sensors are embedded in the tube and on the rings such that they are easily positioned using technician's fingers. Other embodiments include rings for mounting sensors on and for steadying the sensors. The hand and finger mounted sensors may be used to provide necessary pressure to the sensor and yet provide a sensor that may be manipulated using hand and finger motion. In other embodiments sensors having a local disconnect are disclosed. Such disconnects may be attached to the clothing of a medical professional, attached via a wrist or armband or the like. Various sensor packages may be accompanied by the use of a flat or flex cable to minimize the torque necessary to manipulate the sensor. Such sensors can be used with a ultrasound platform for generating, processing and displaying ultrasound images.

Correspondence Address:
CHRISTIE, PARKER & HALE, LLP
PO BOX 7068
PASADENA, CA 91109-7068 (US)

(21) Appl. No.: **10/863,644**
 (22) Filed: **Jun. 8, 2004**

Related U.S. Application Data

(63) Continuation-in-part of application No. 10/724,382, filed on Nov. 26, 2003.
 (60) Provisional application No. 60/429,614, filed on Nov. 27, 2002.

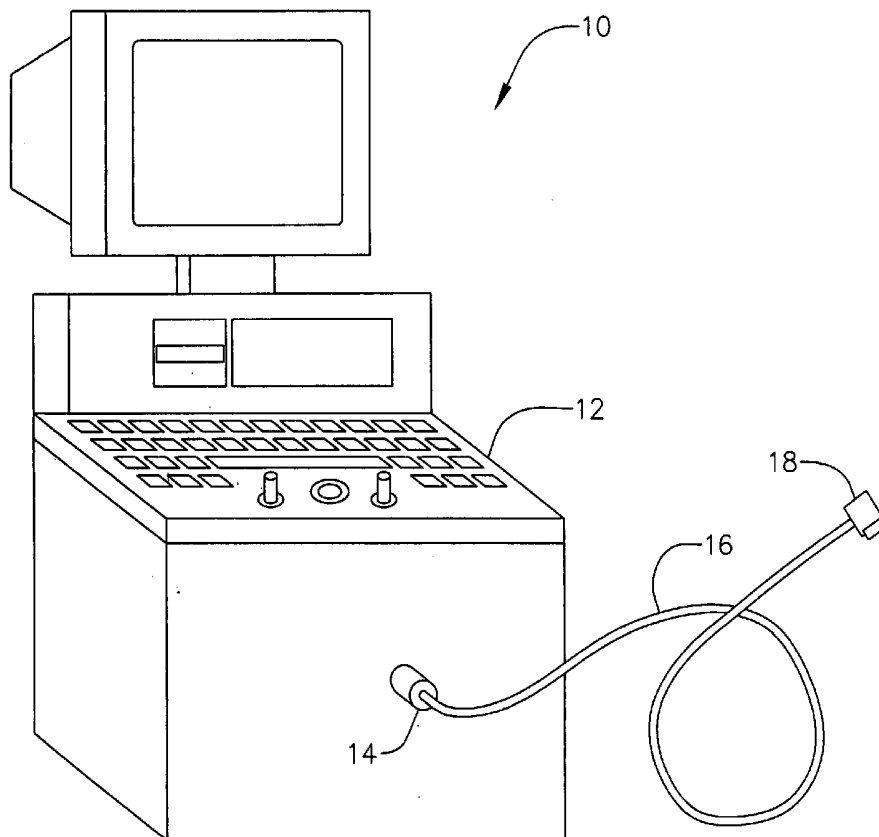
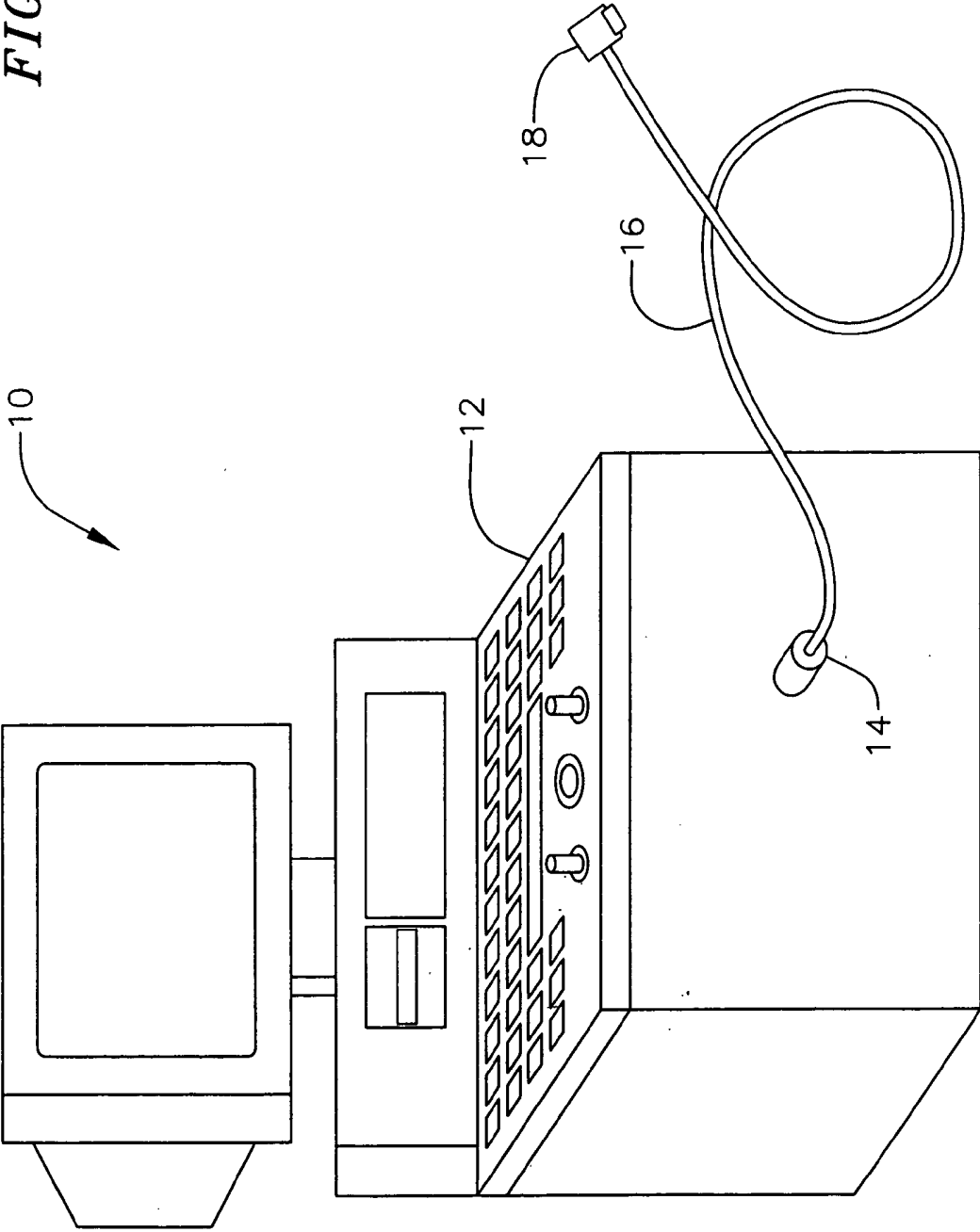
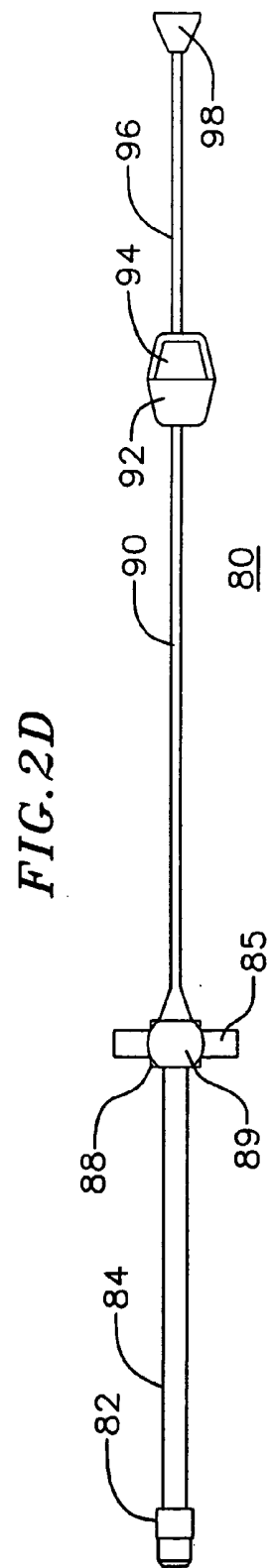
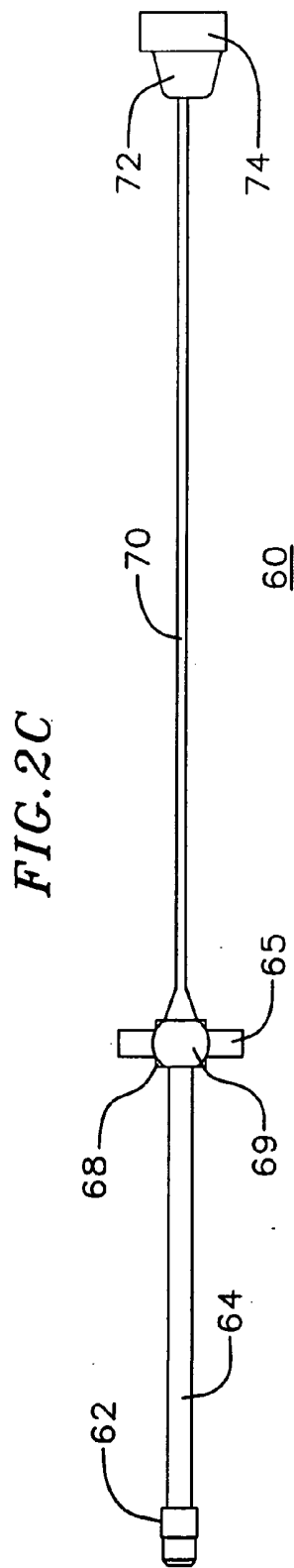
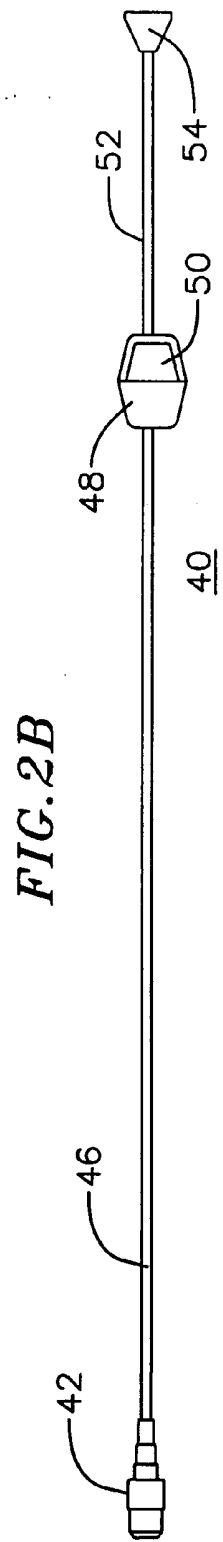
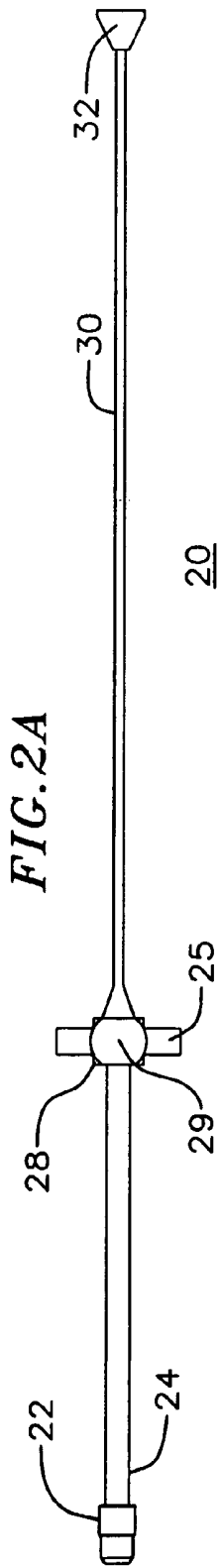

FIG. 1





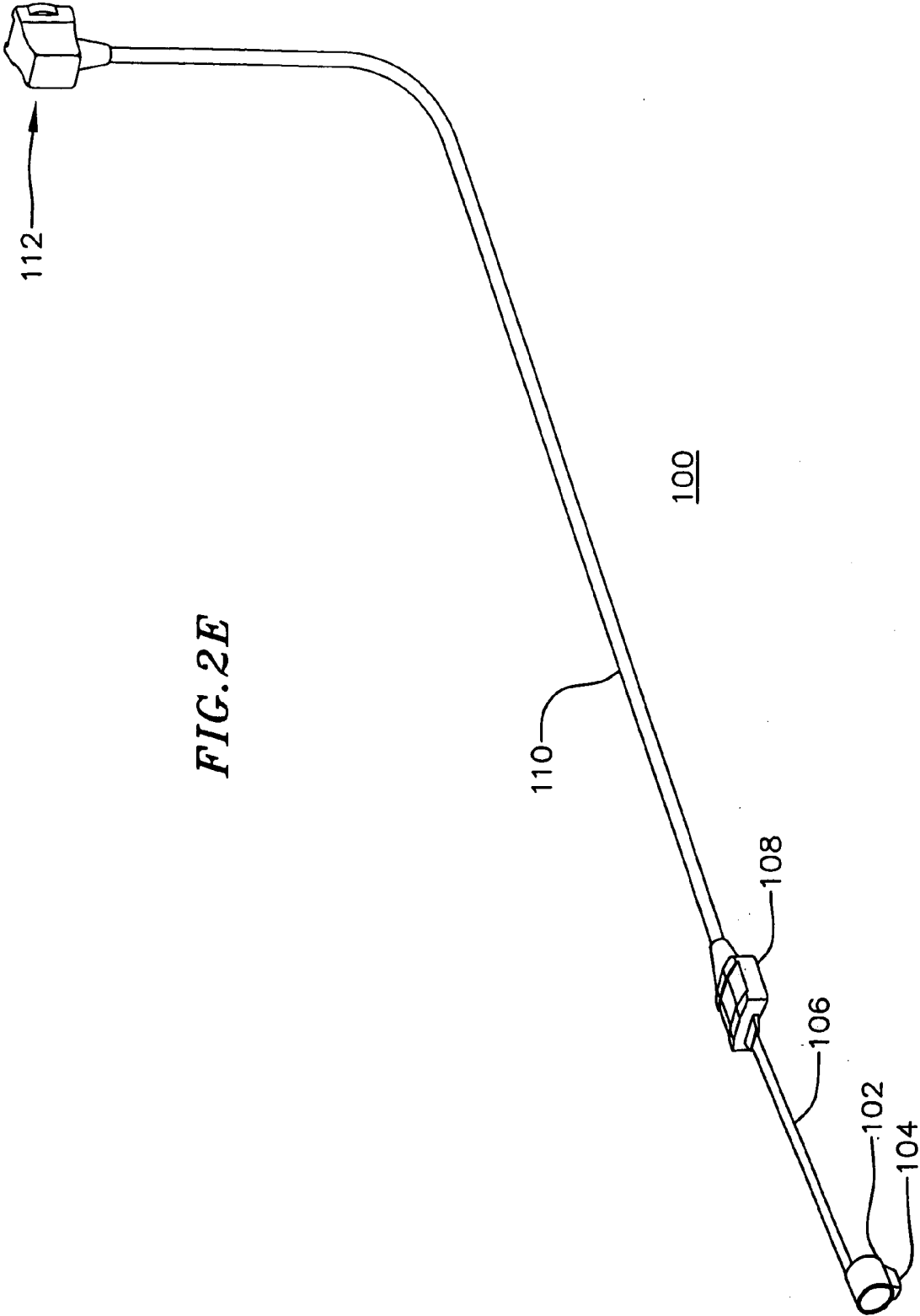
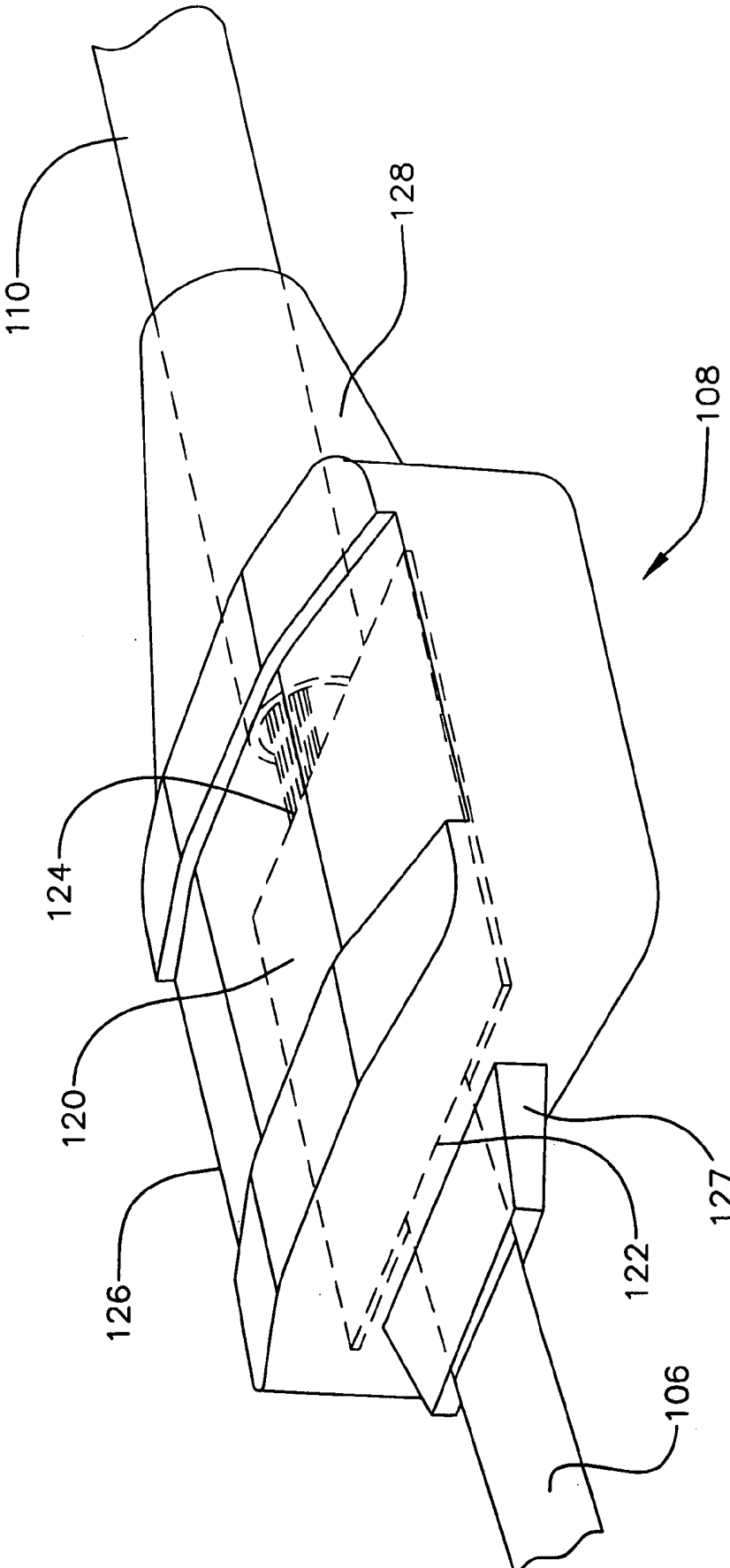

FIG. 2E

FIG. 3



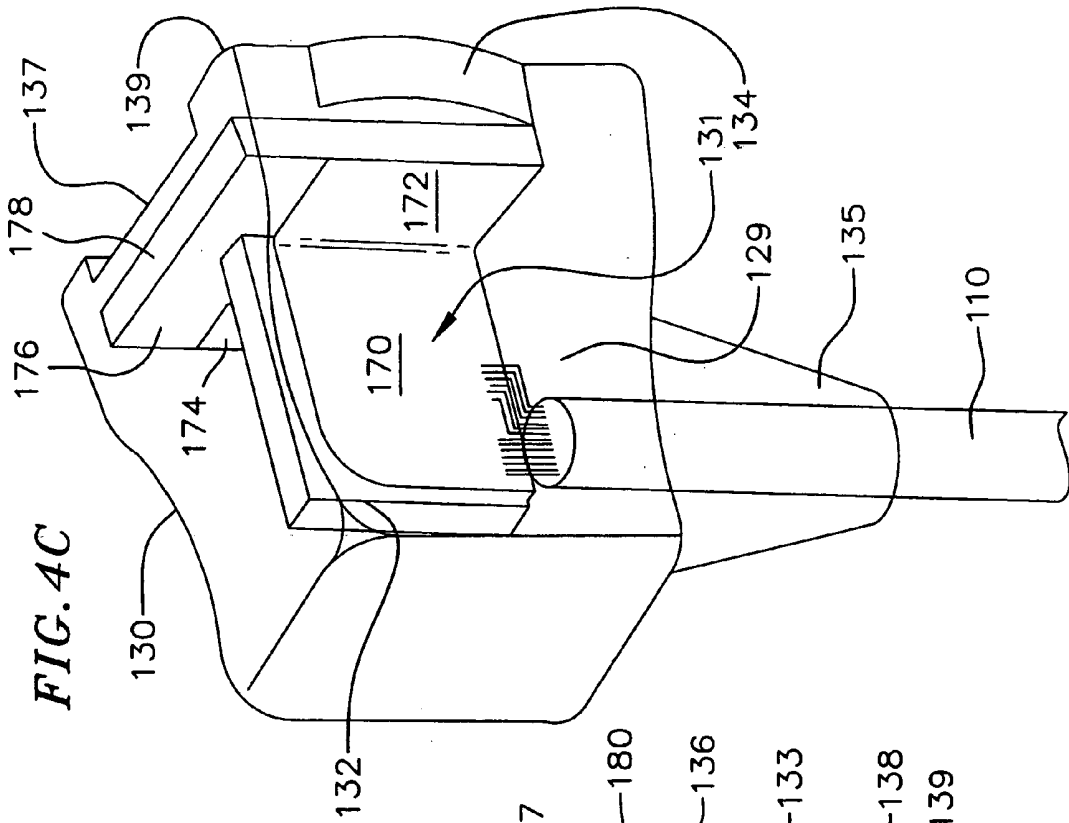

FIG. 4A

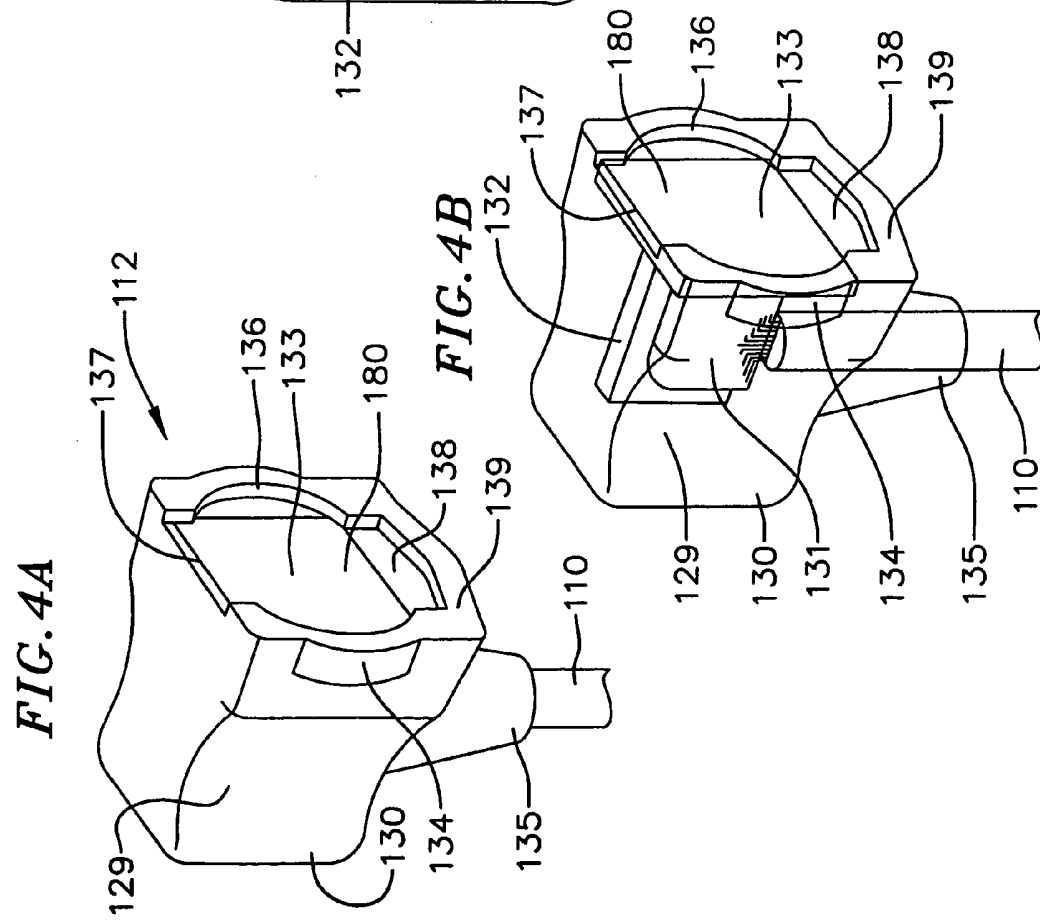

FIG. 4B



FIG. 4C

FIG. 5A

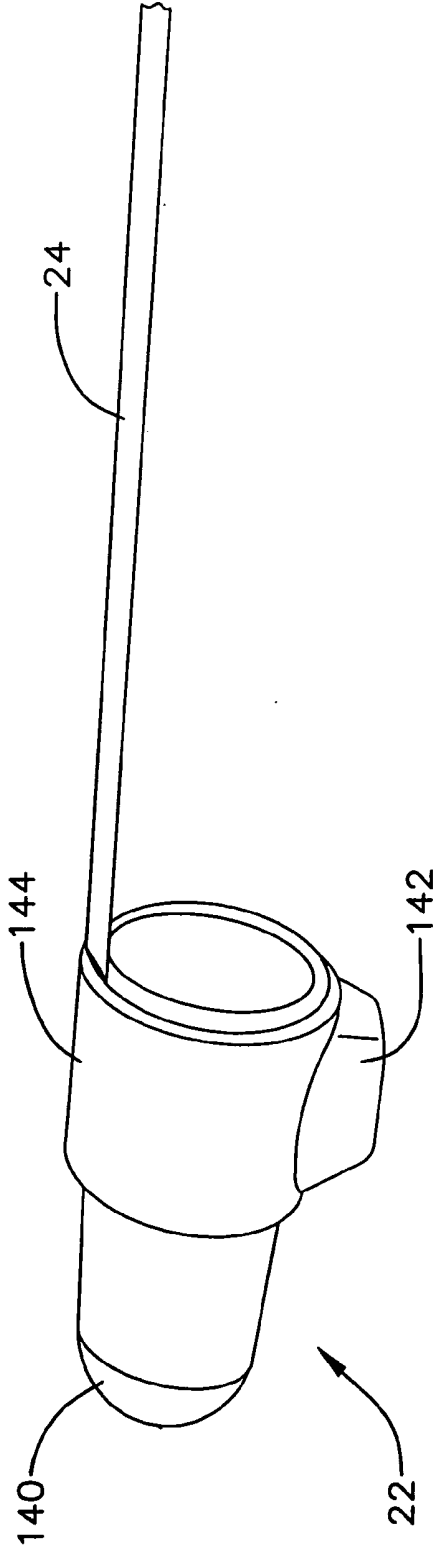
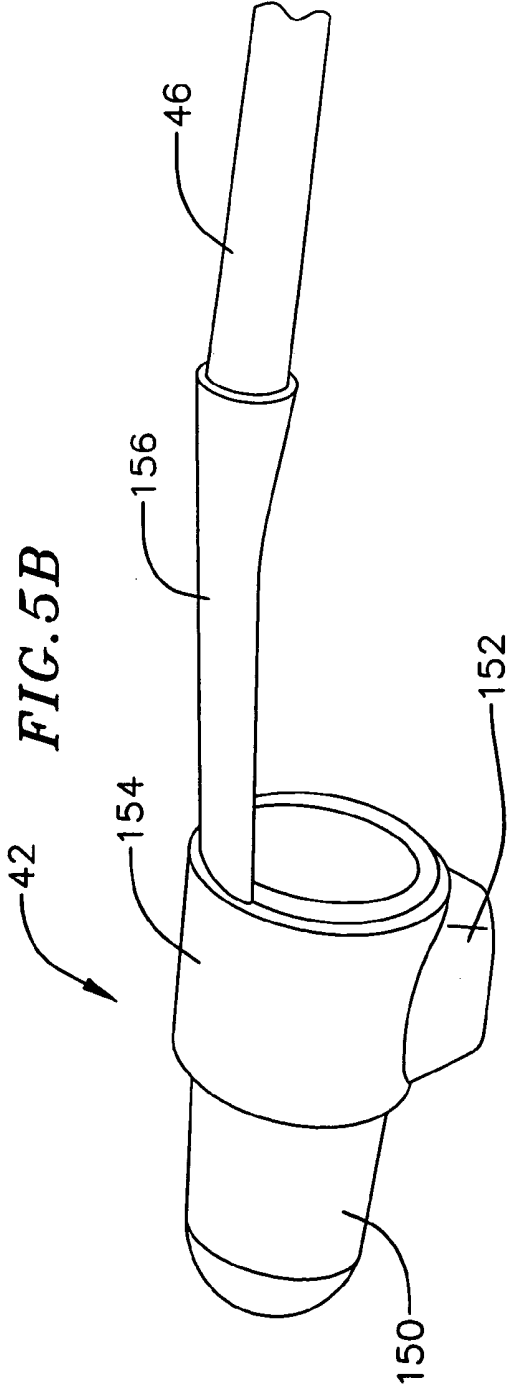
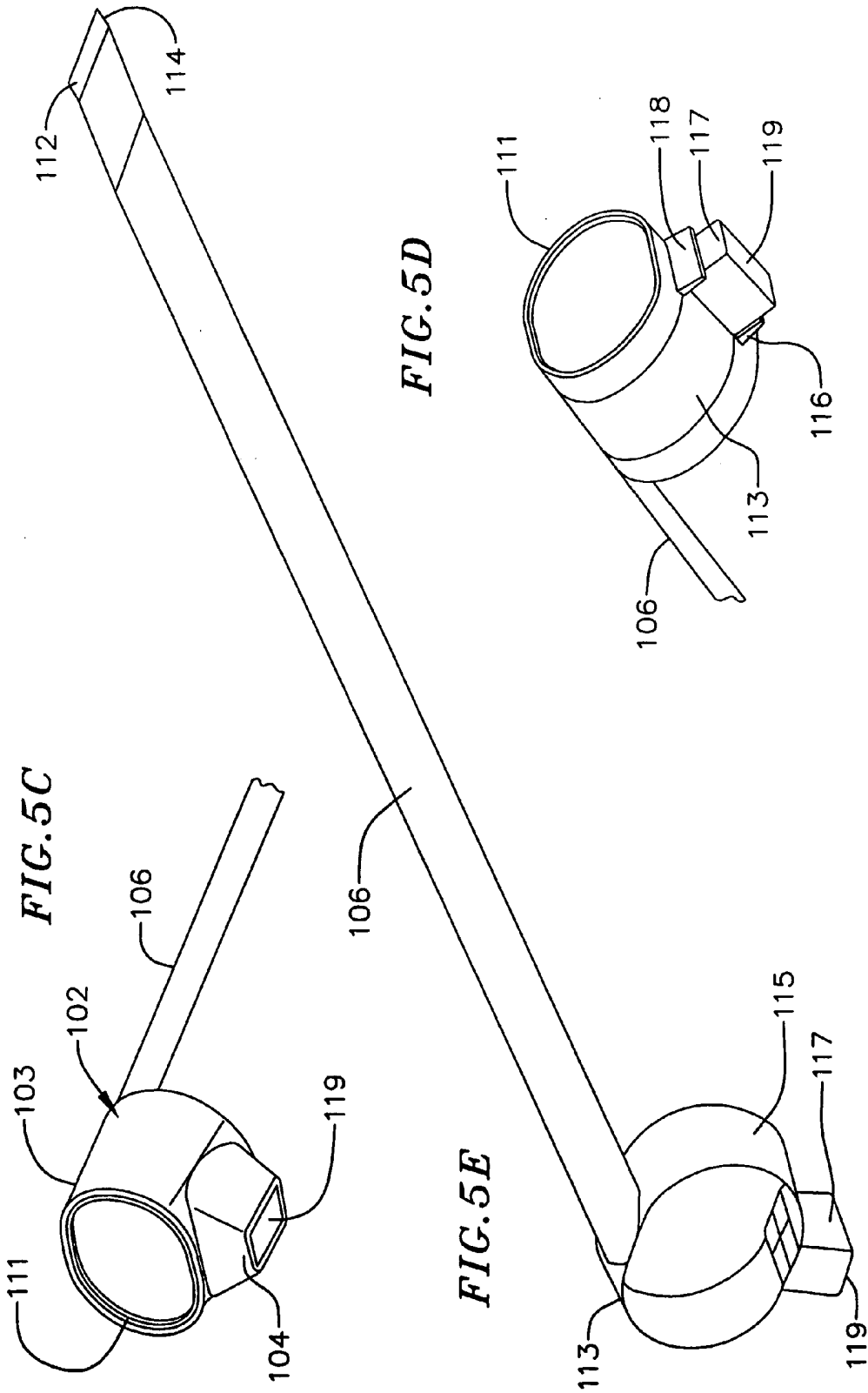
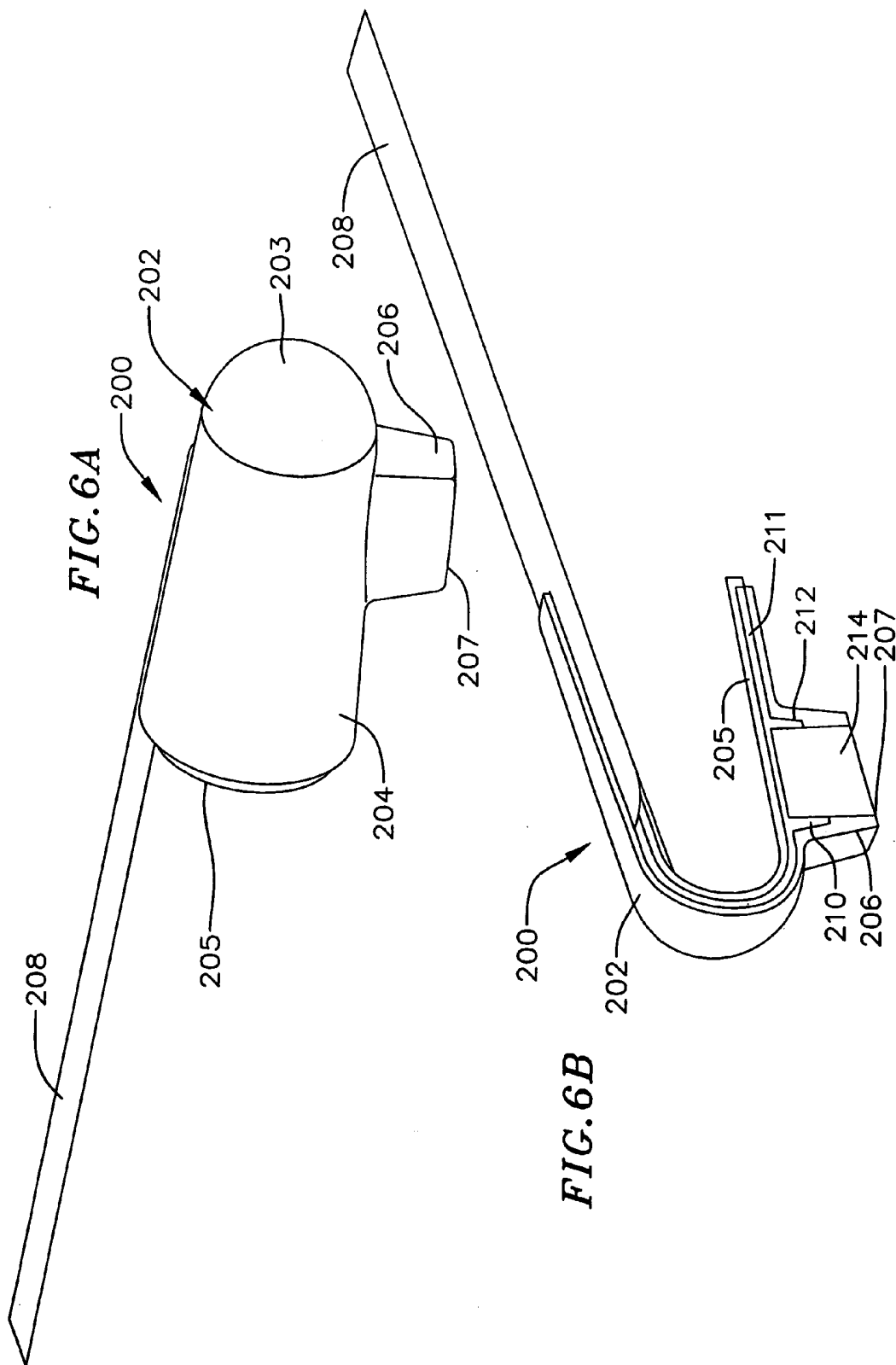

FIG. 5B







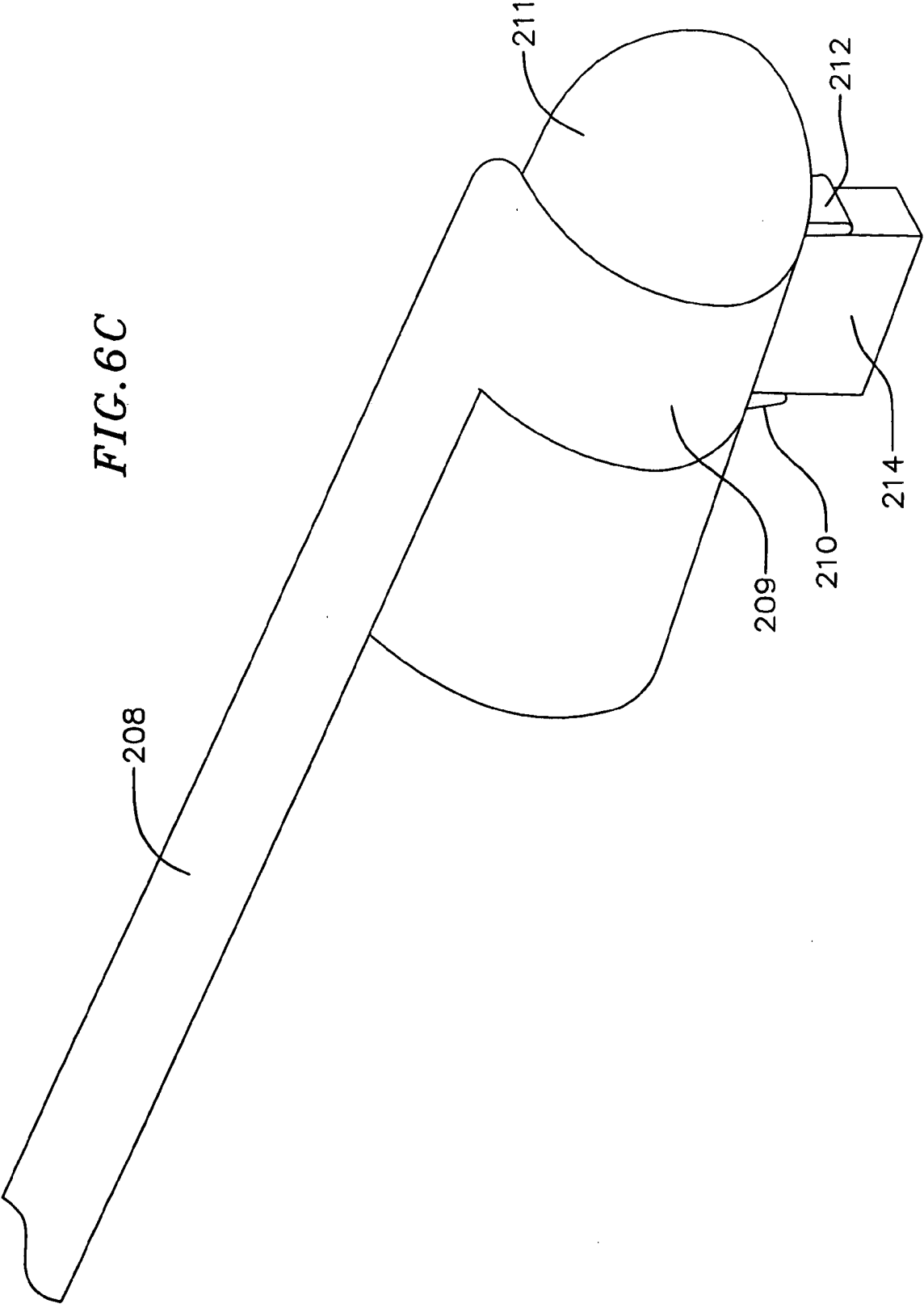

FIG. 6C

FIG. 7B

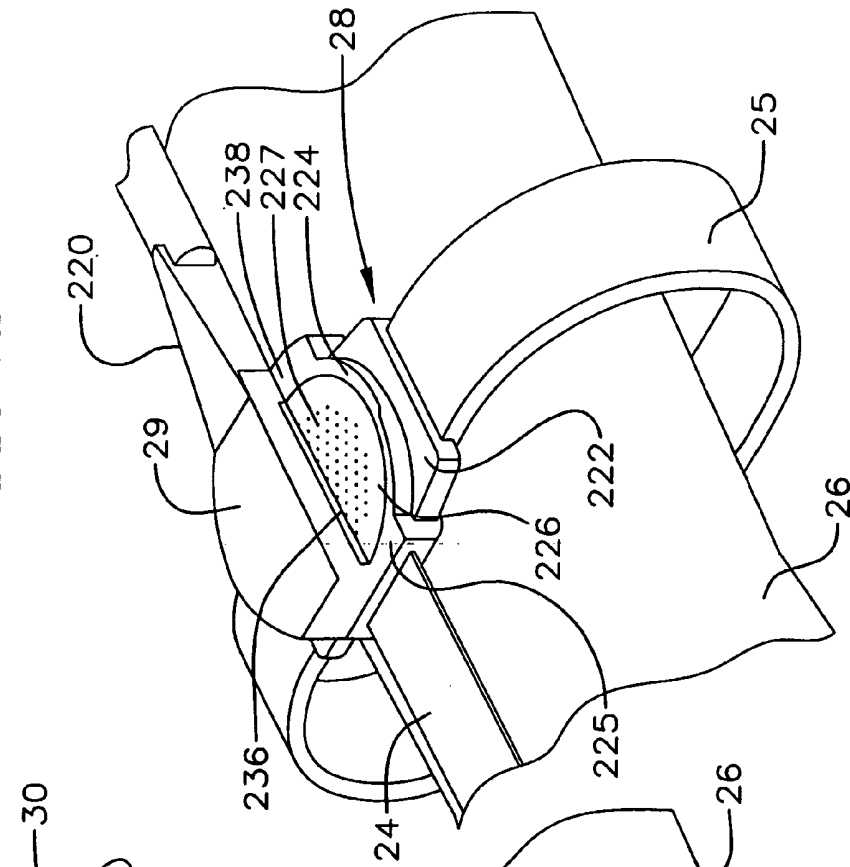
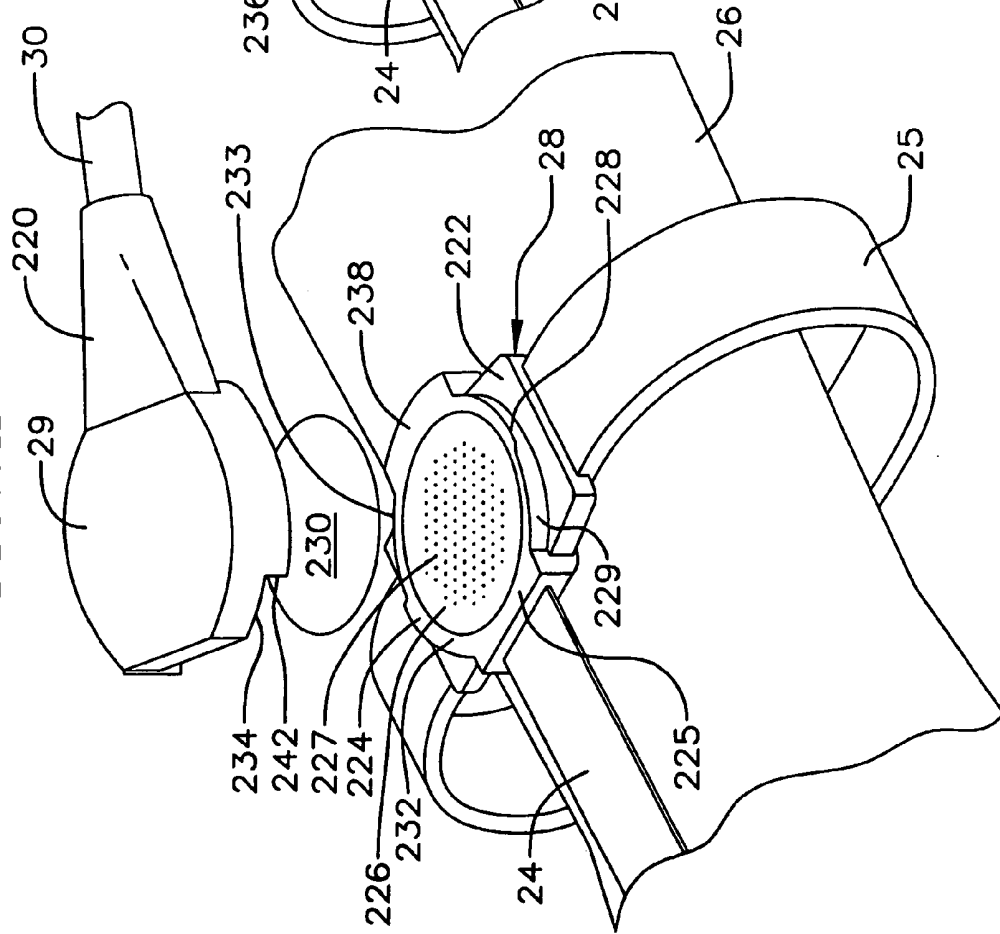

FIG. 7A



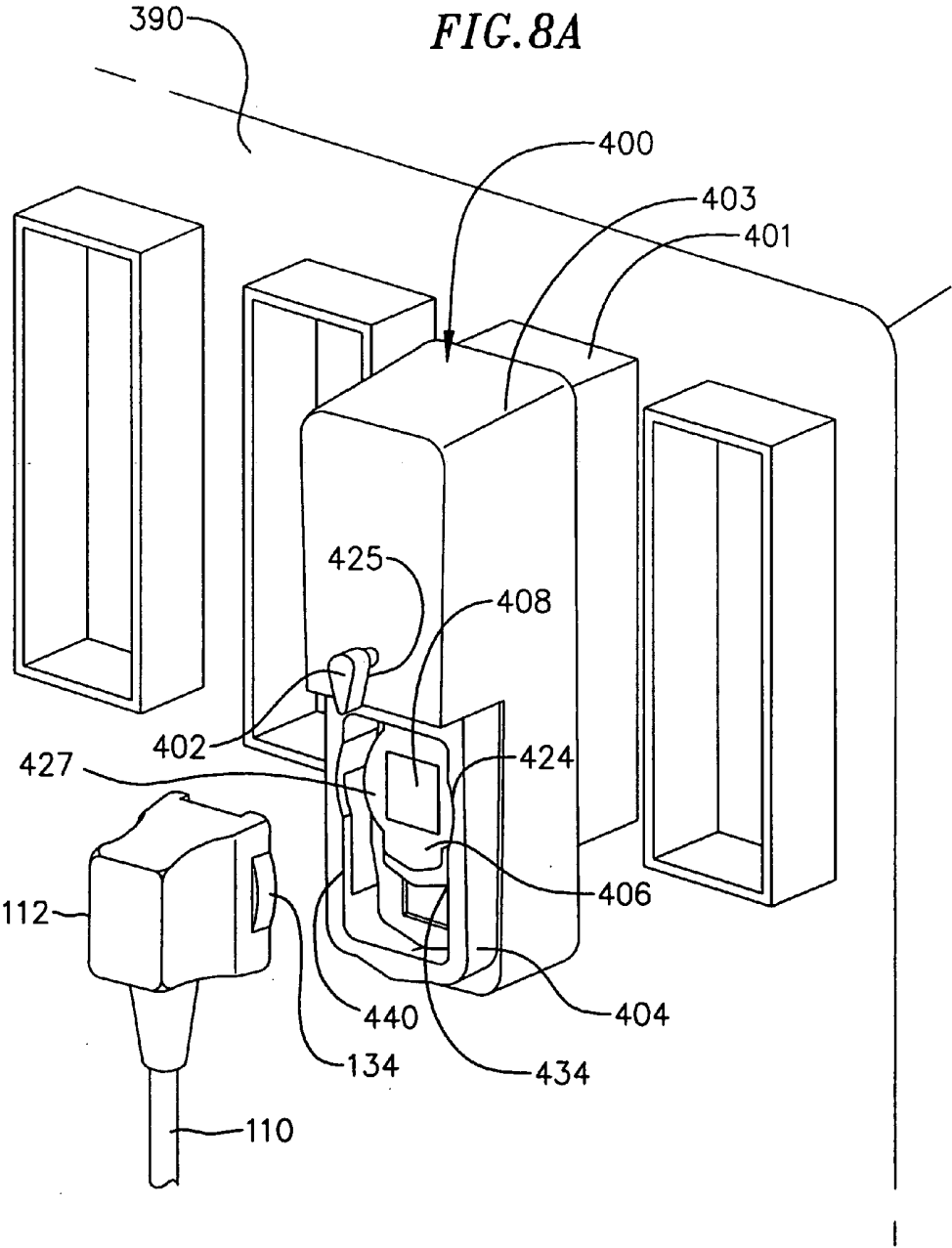
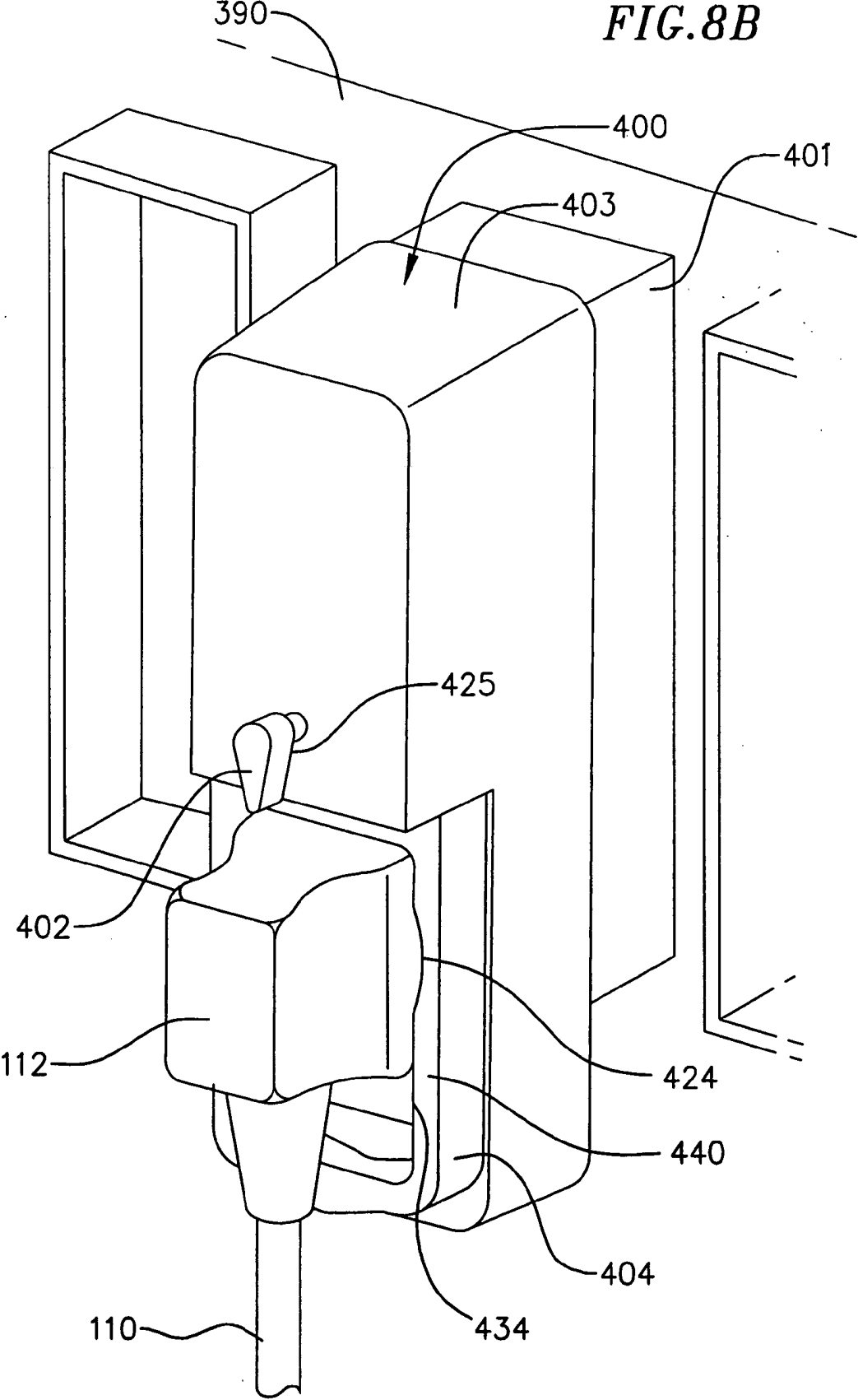
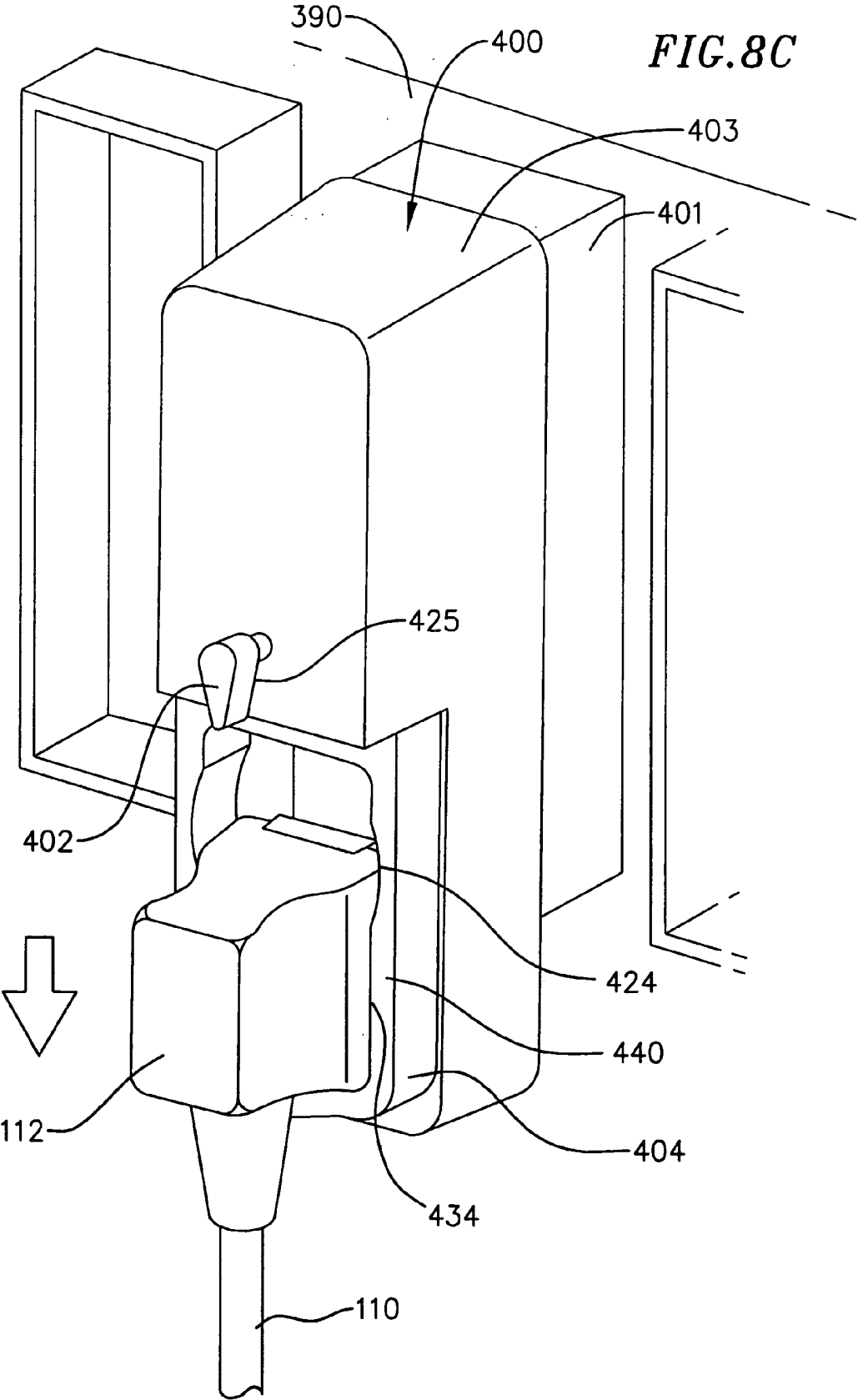

FIG. 8B





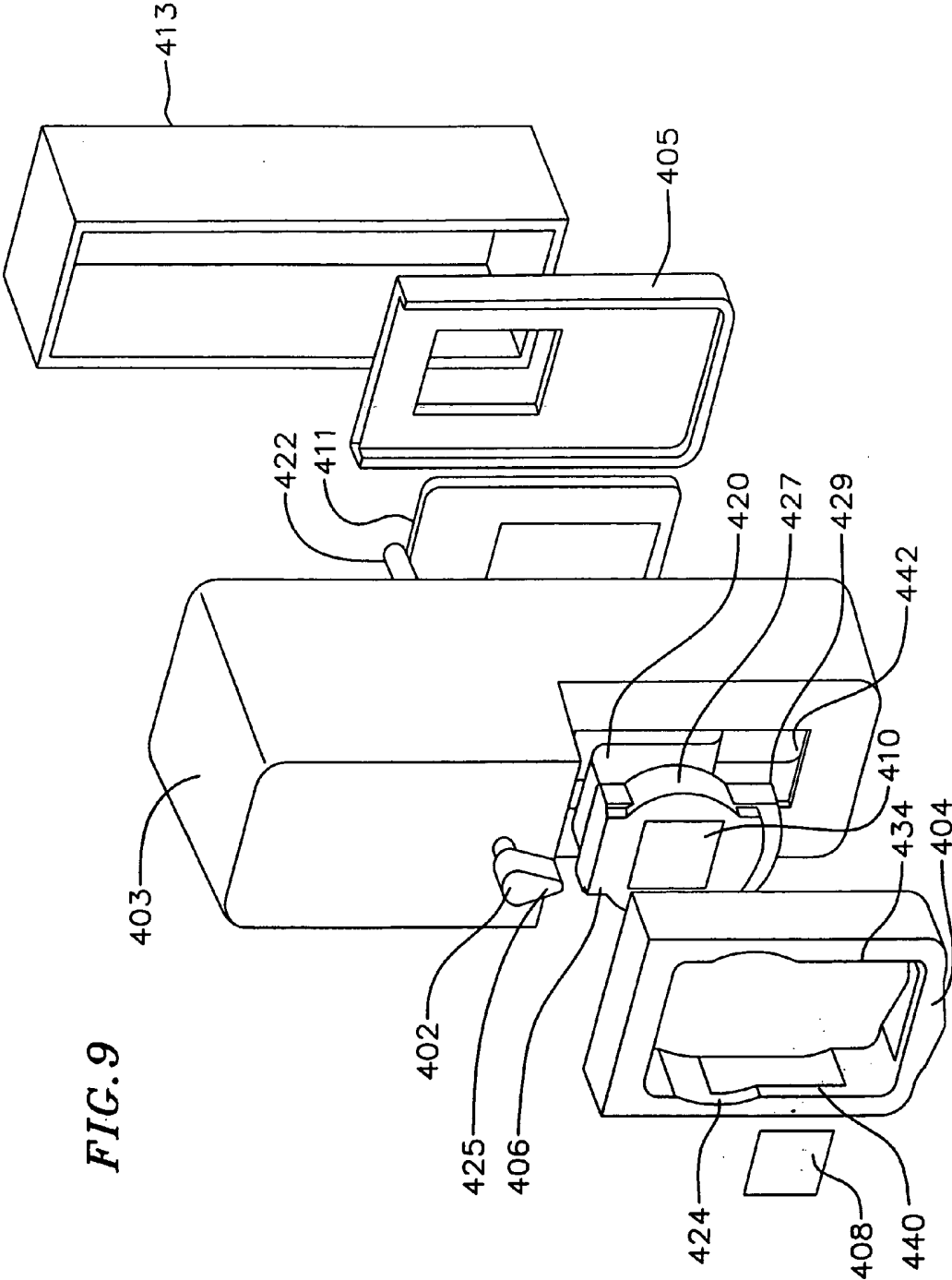
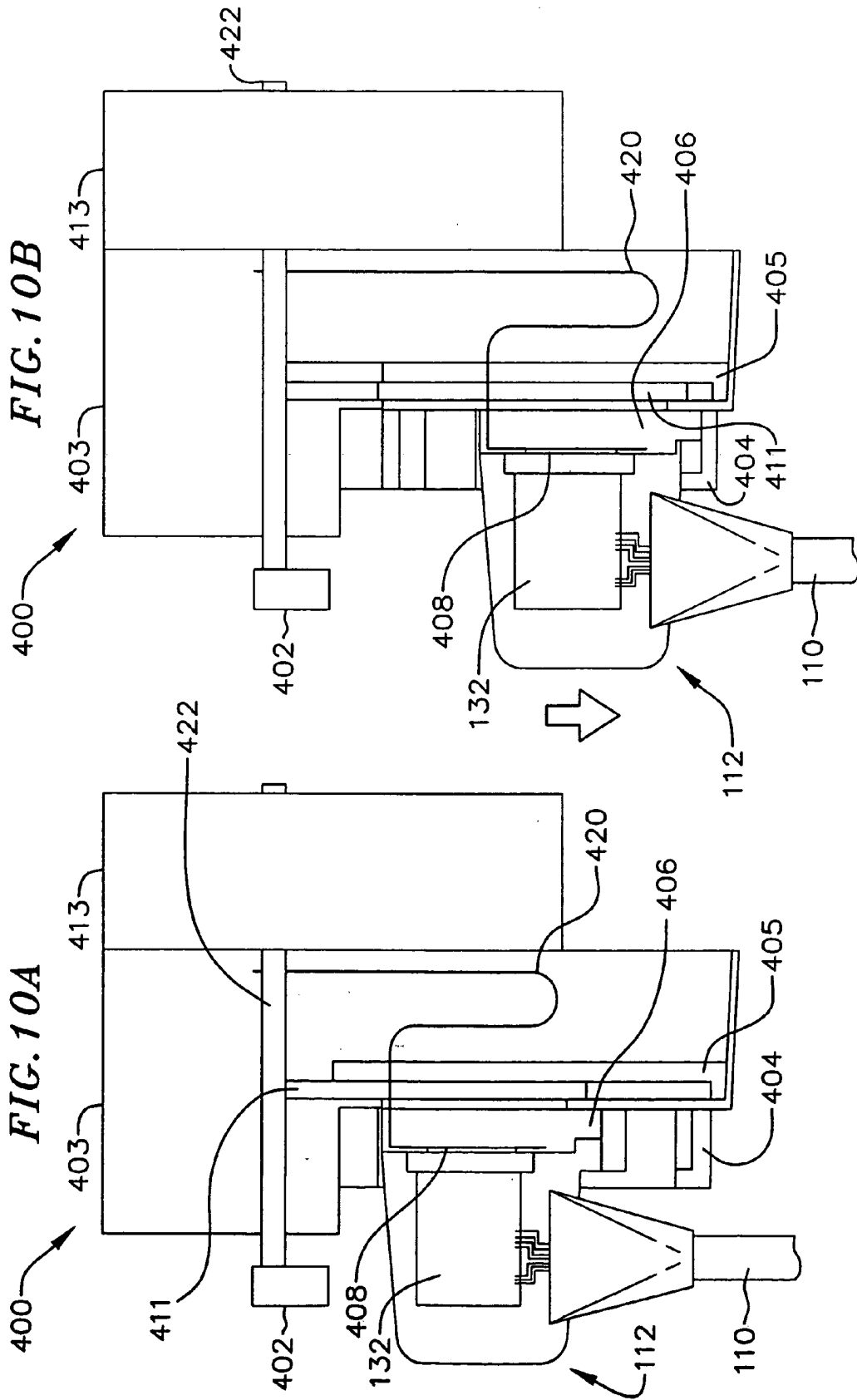

FIG. 9



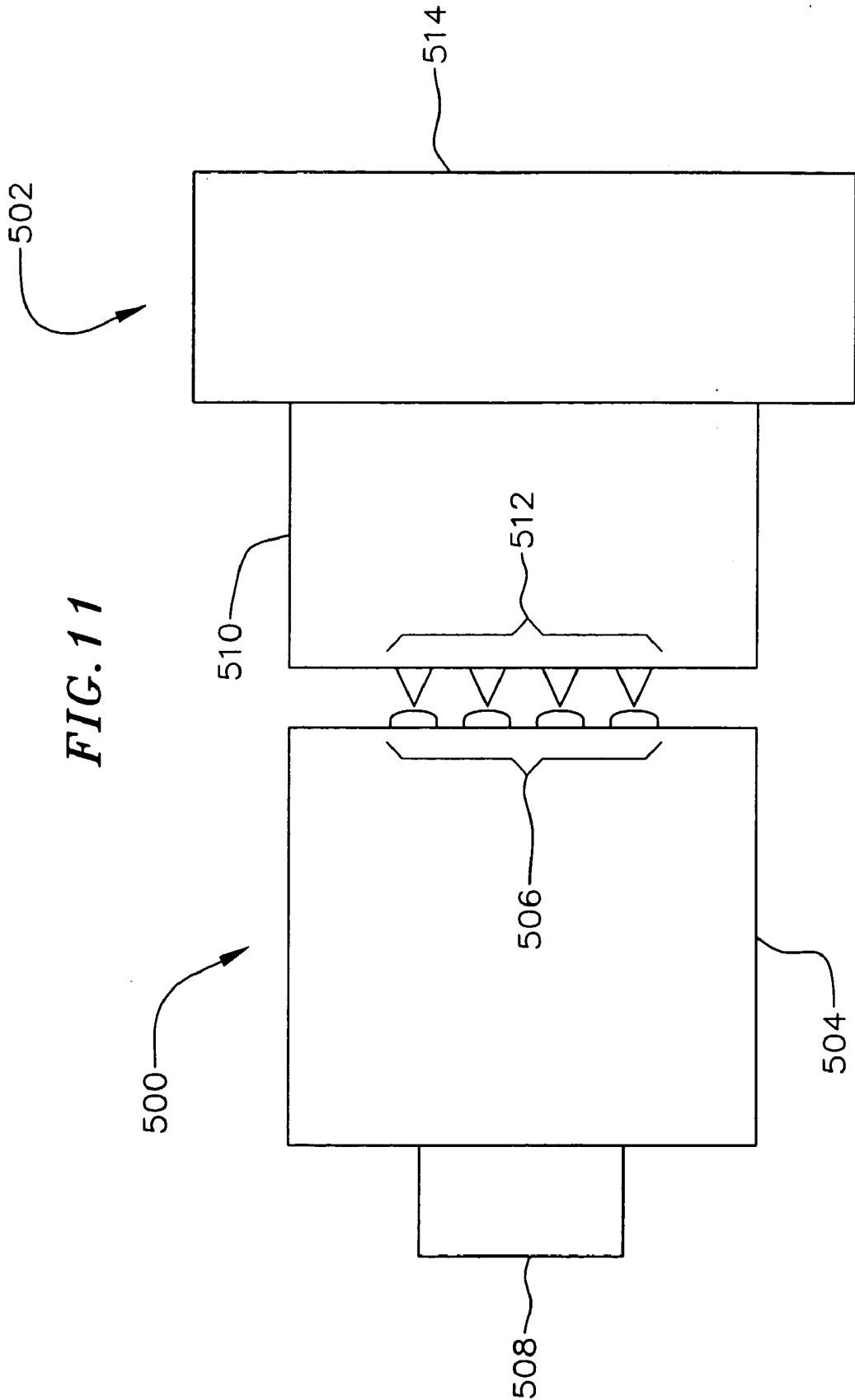

FIG. 12

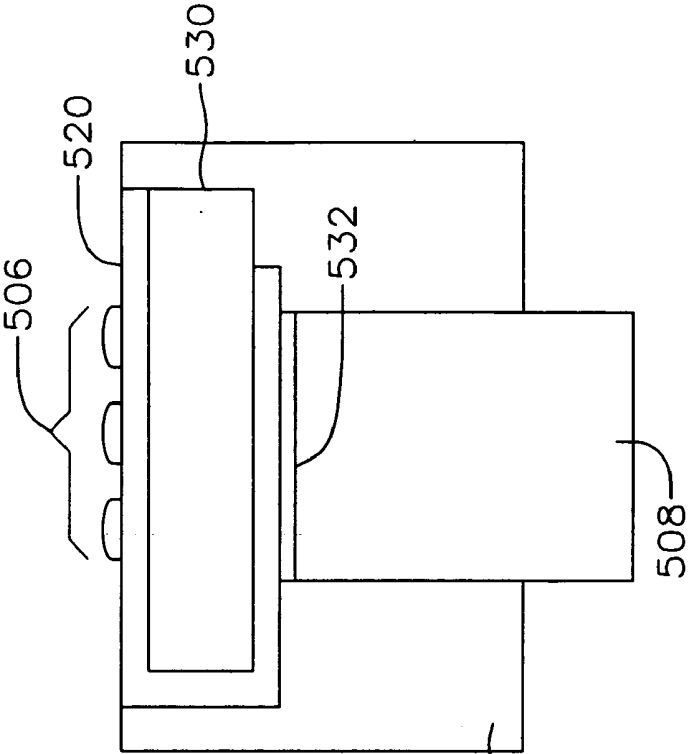
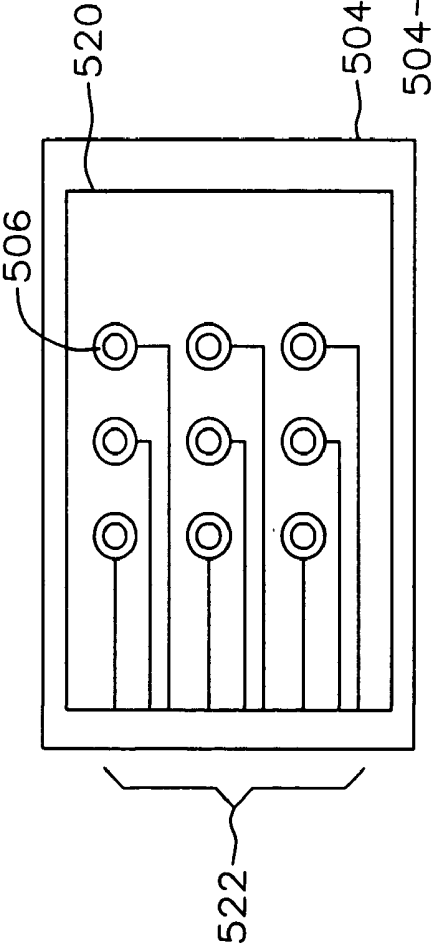

FIG. 13



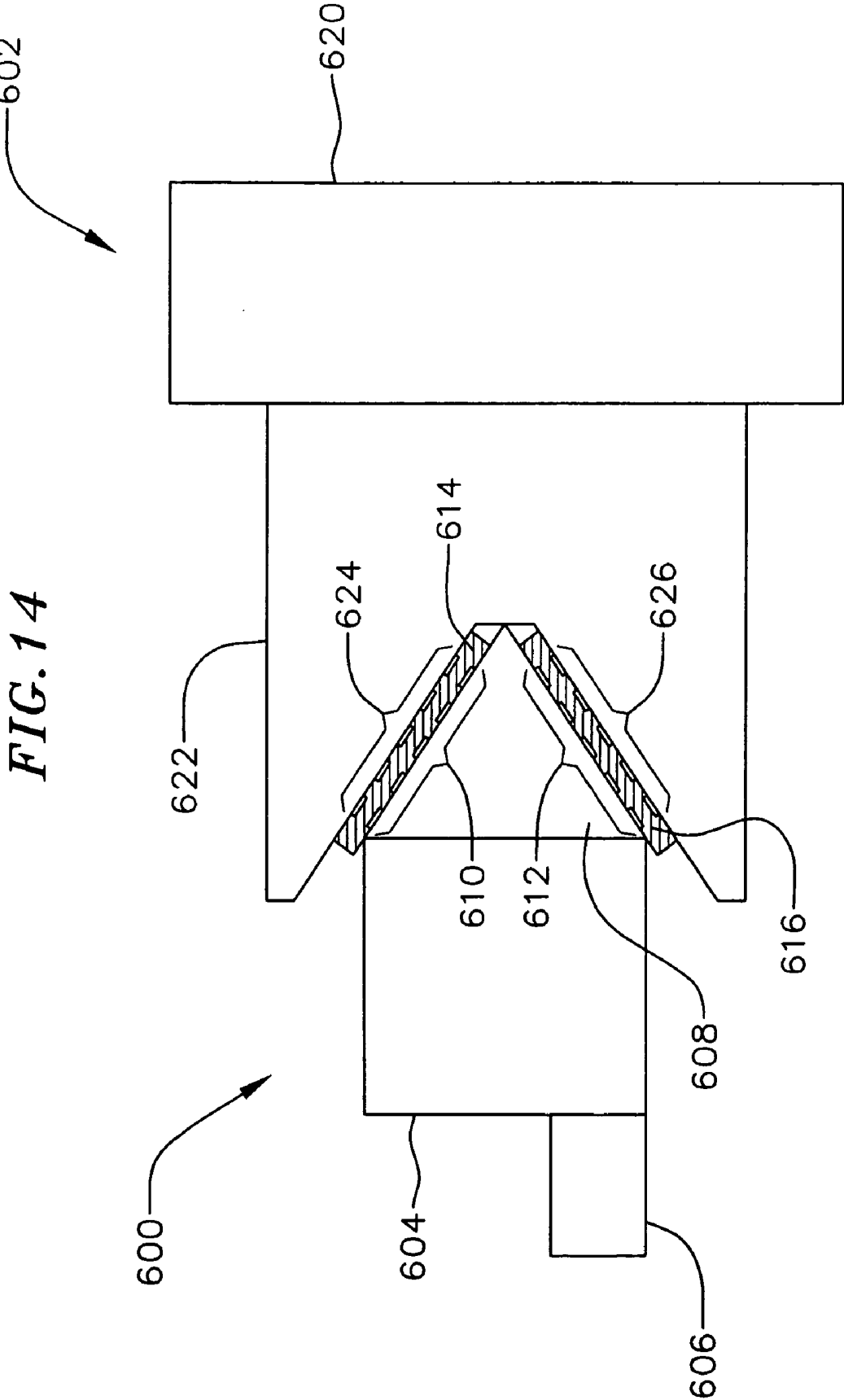
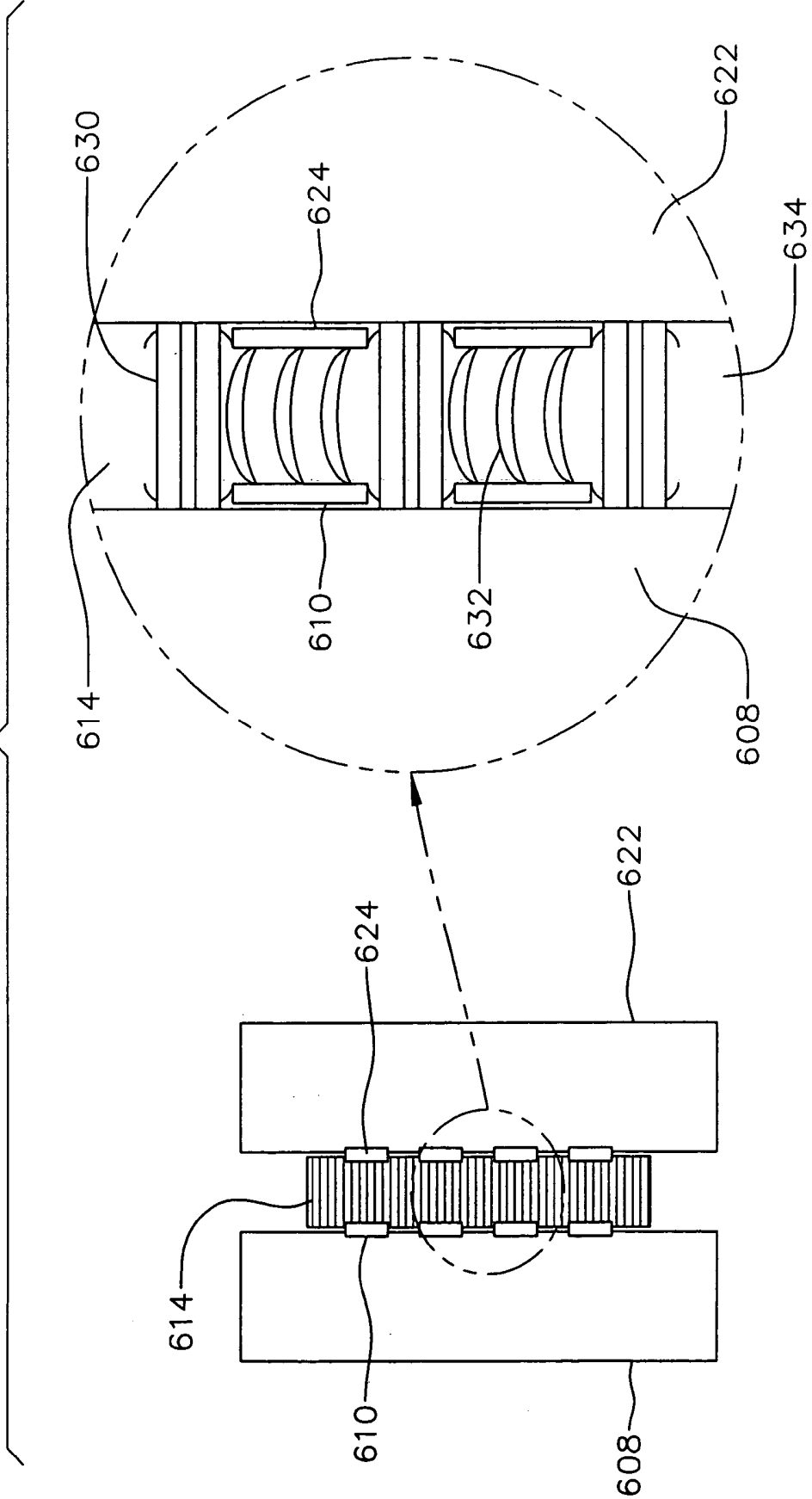

FIG. 14

FIG. 15



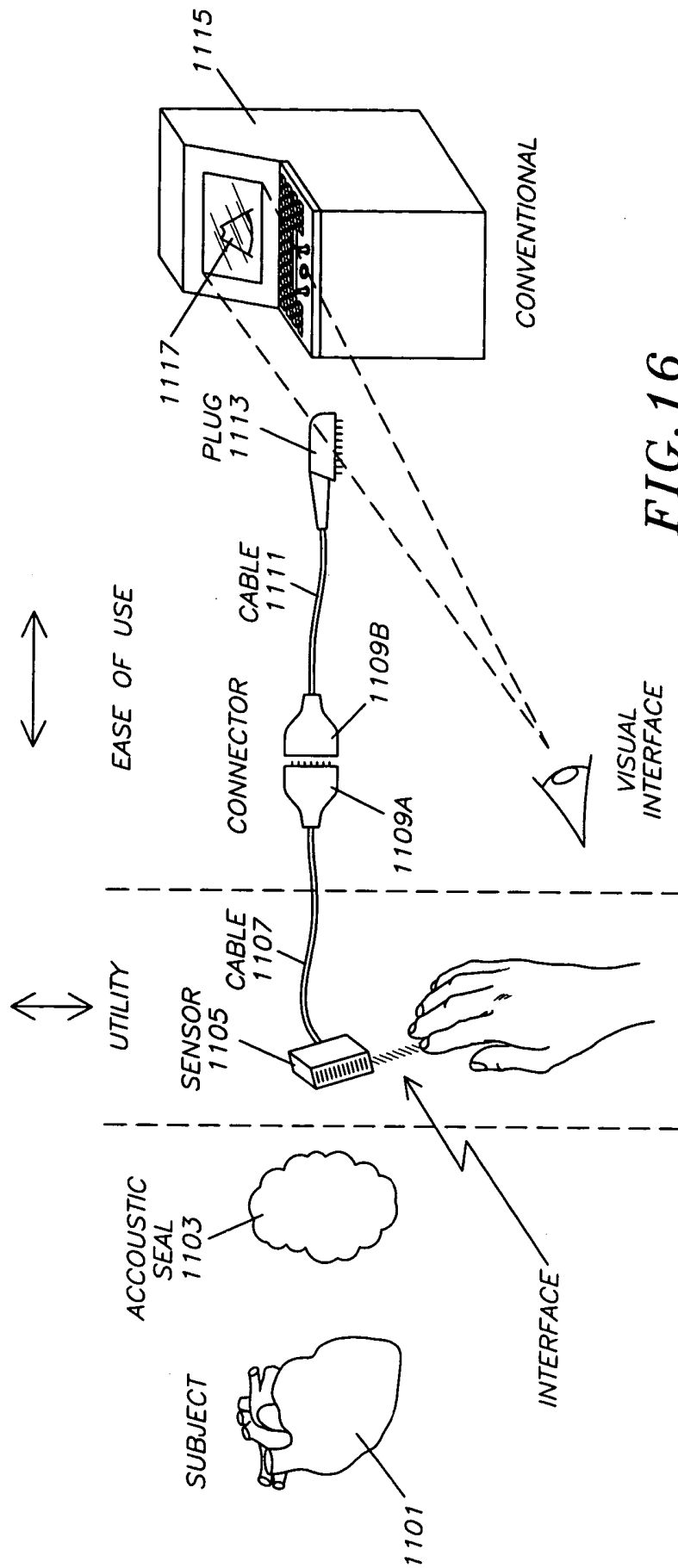

FIG. 16

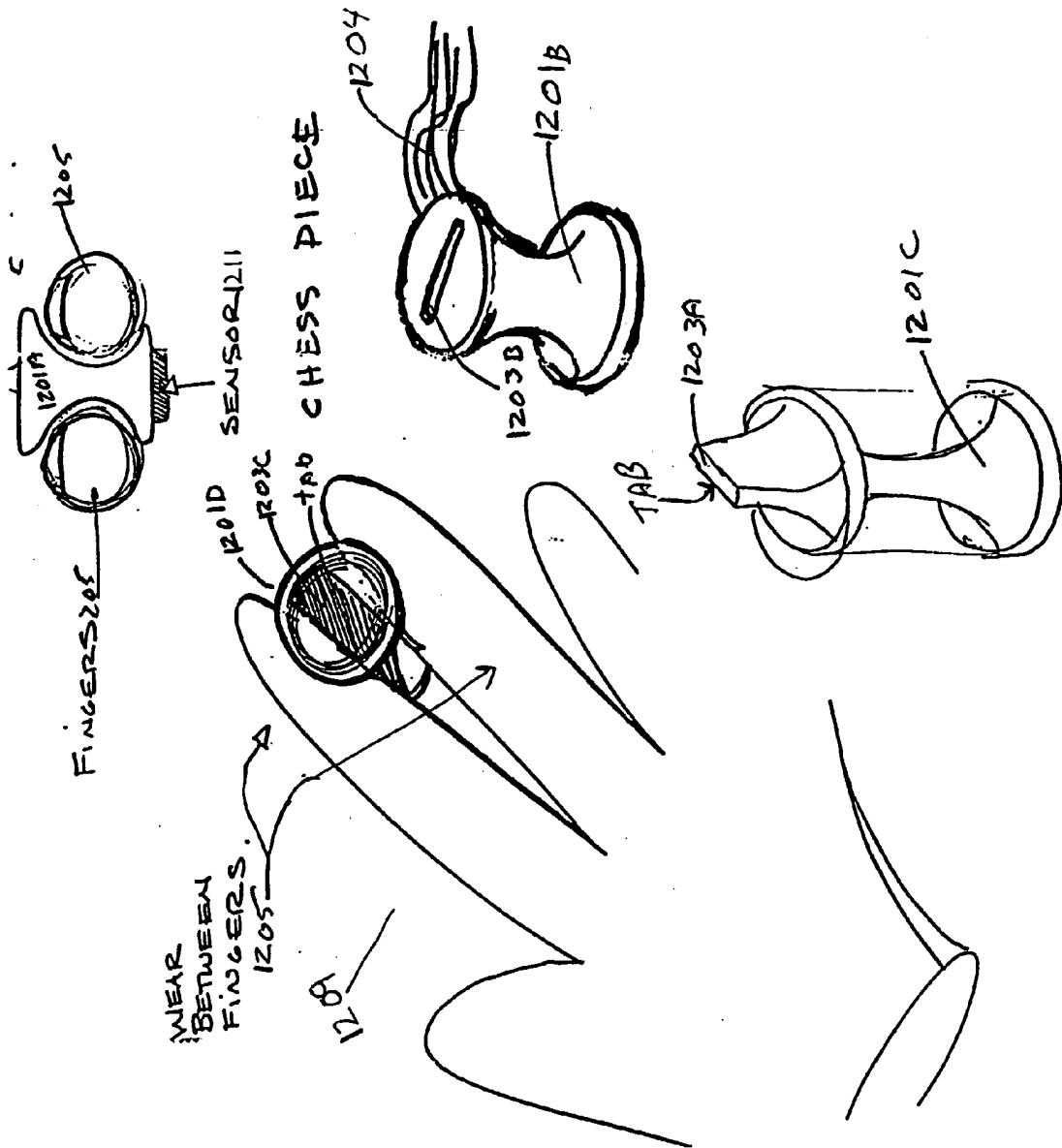
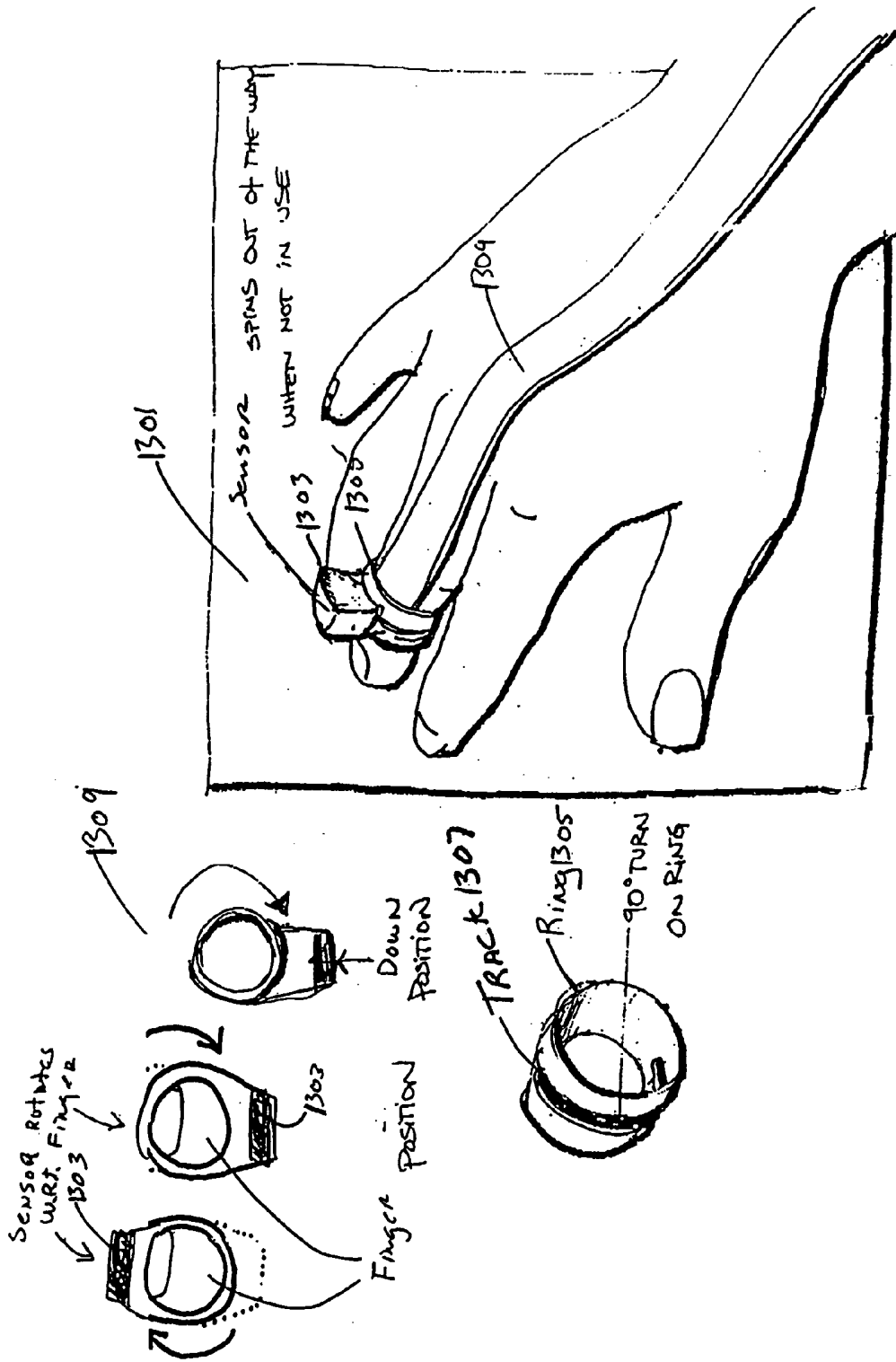

FIG. 17



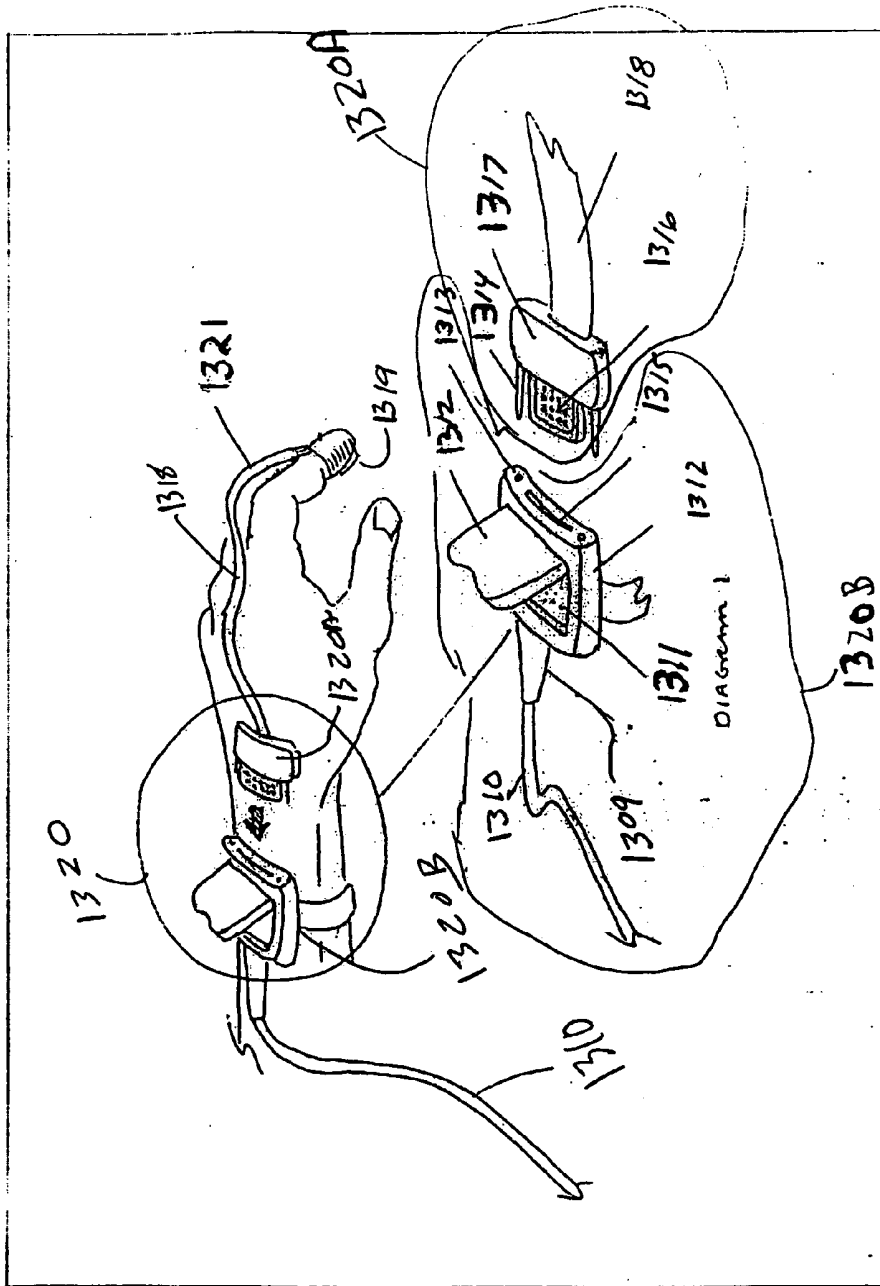

FIG. 18B

sensor is just beyond last digit for
slimline probe for rectal exams & other

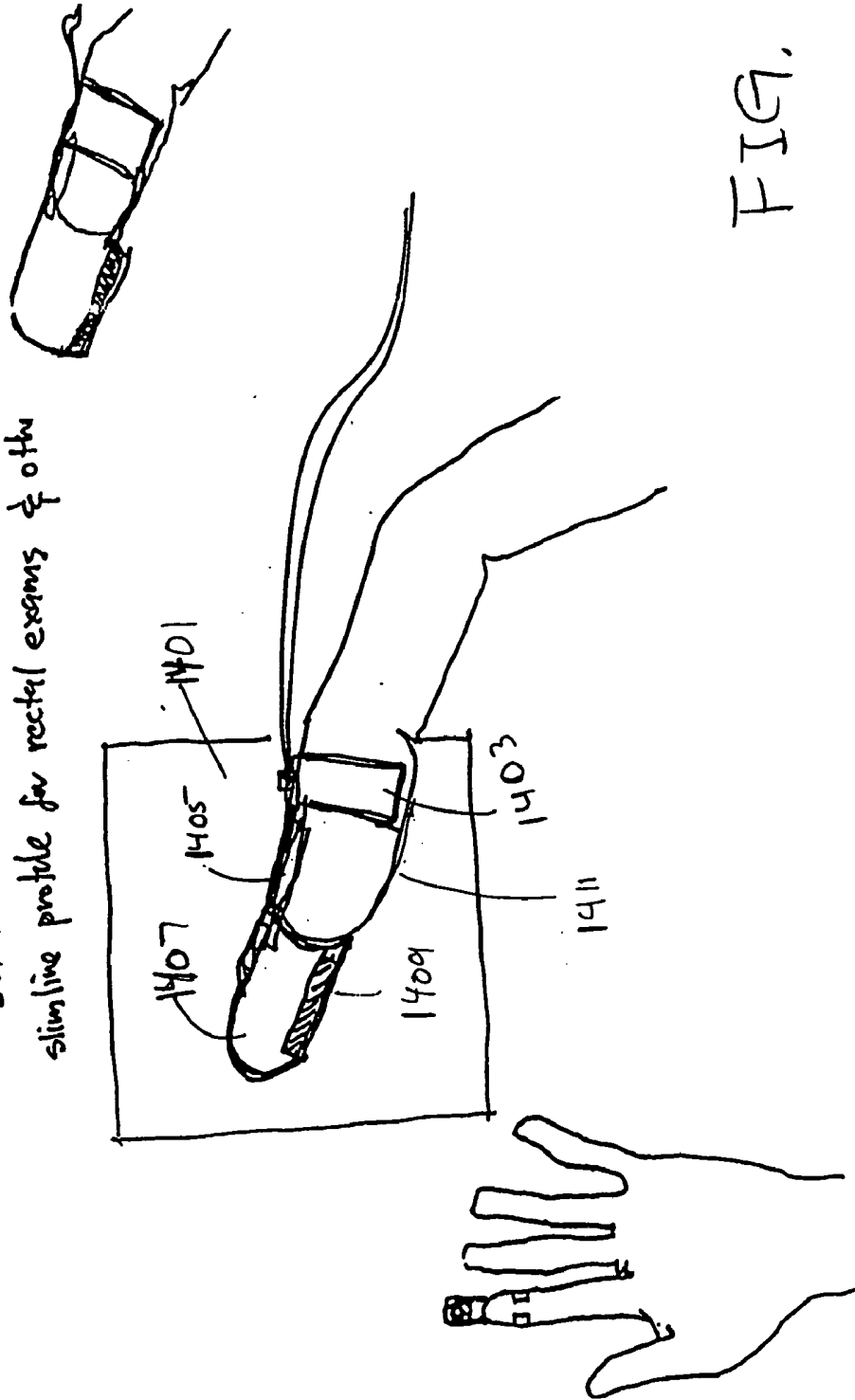
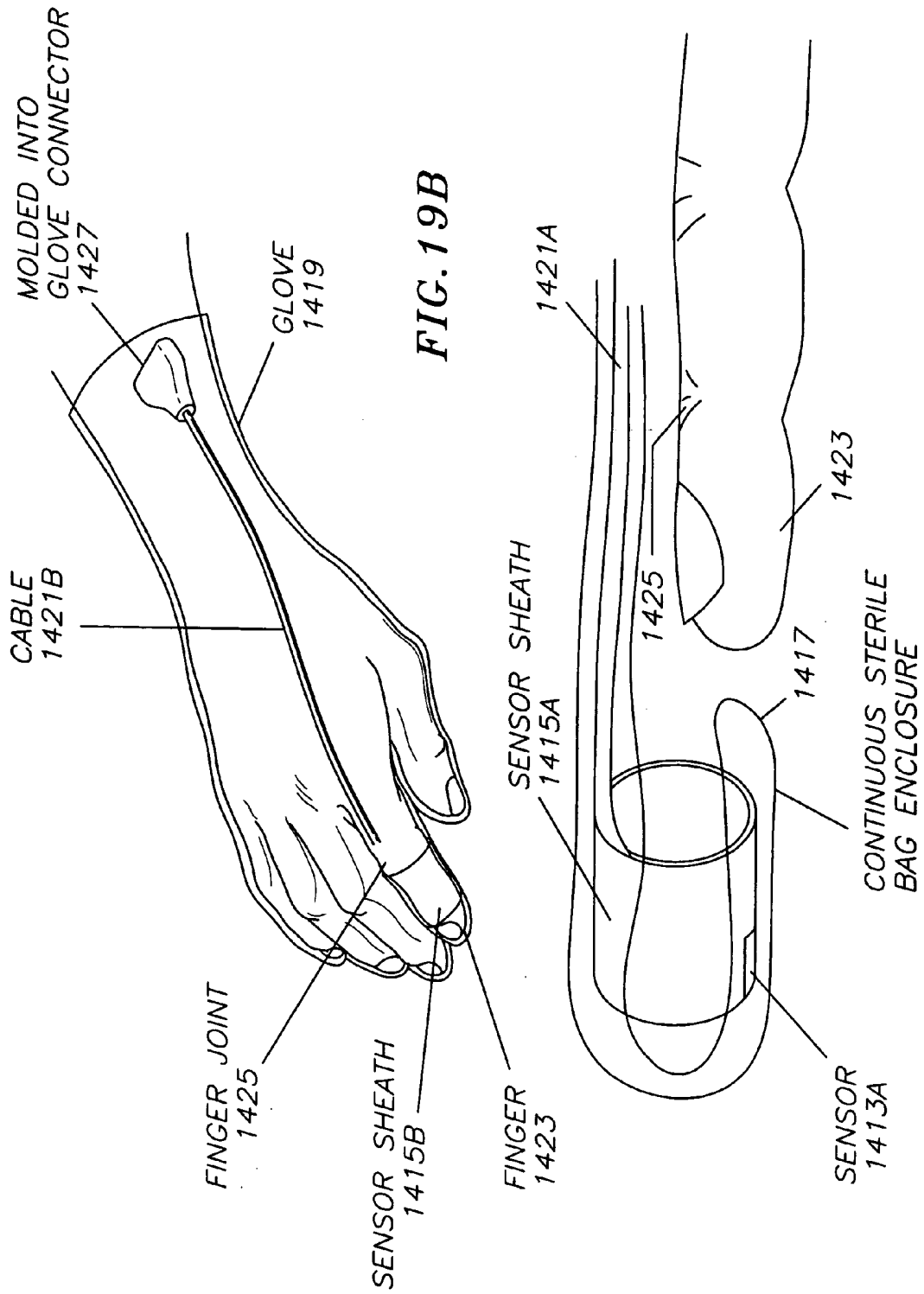

FIG. 19A



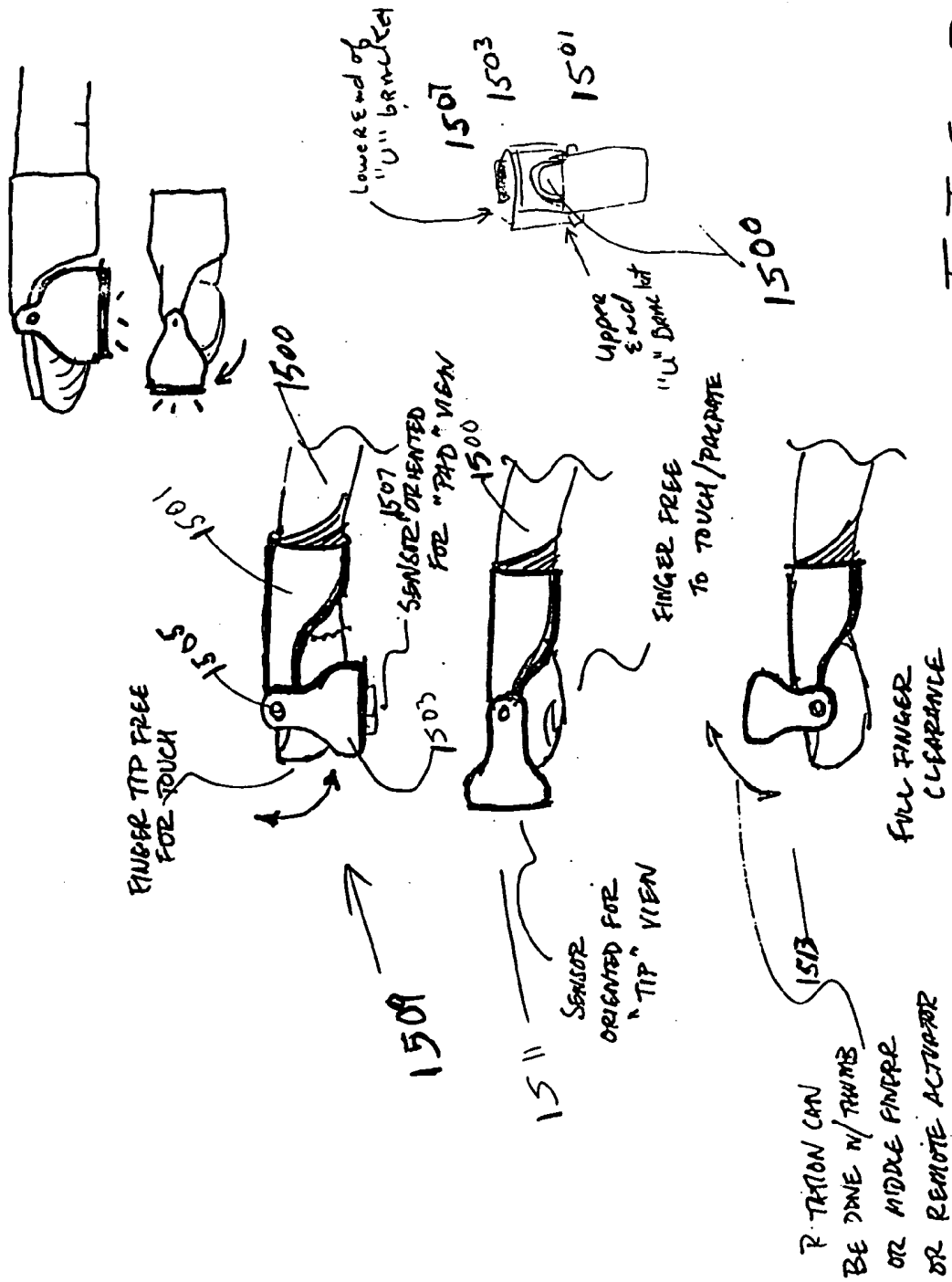
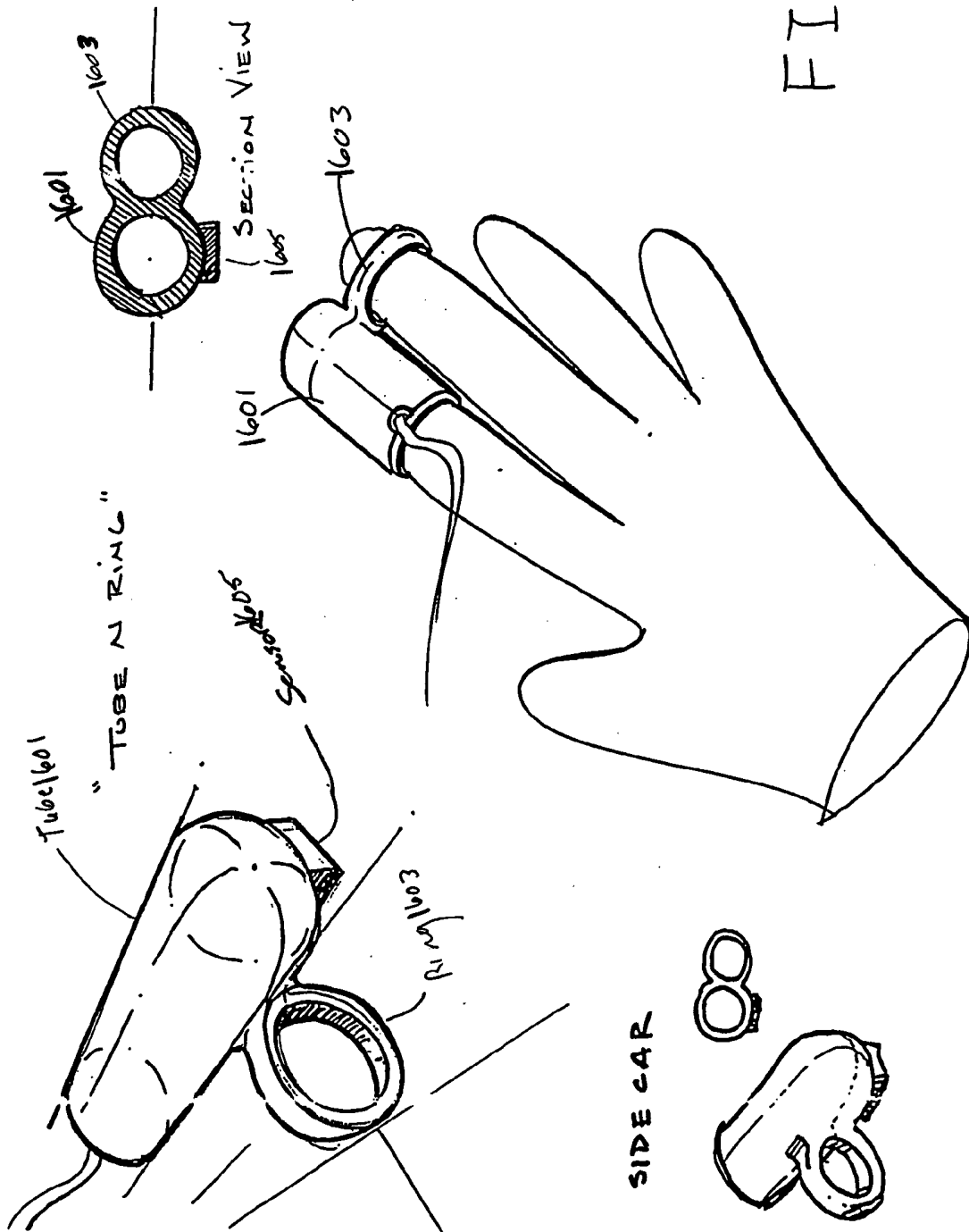
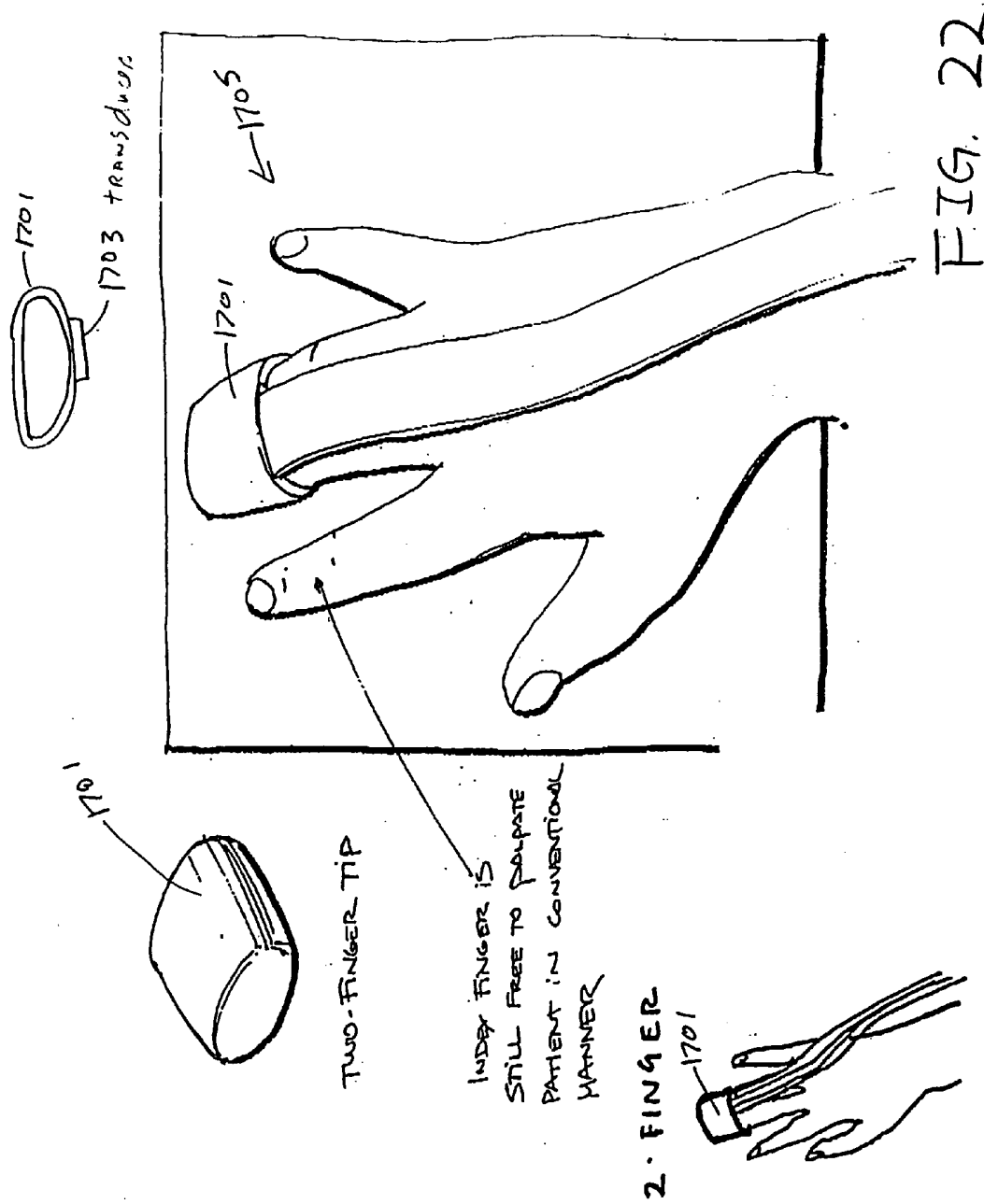

FIG. 20





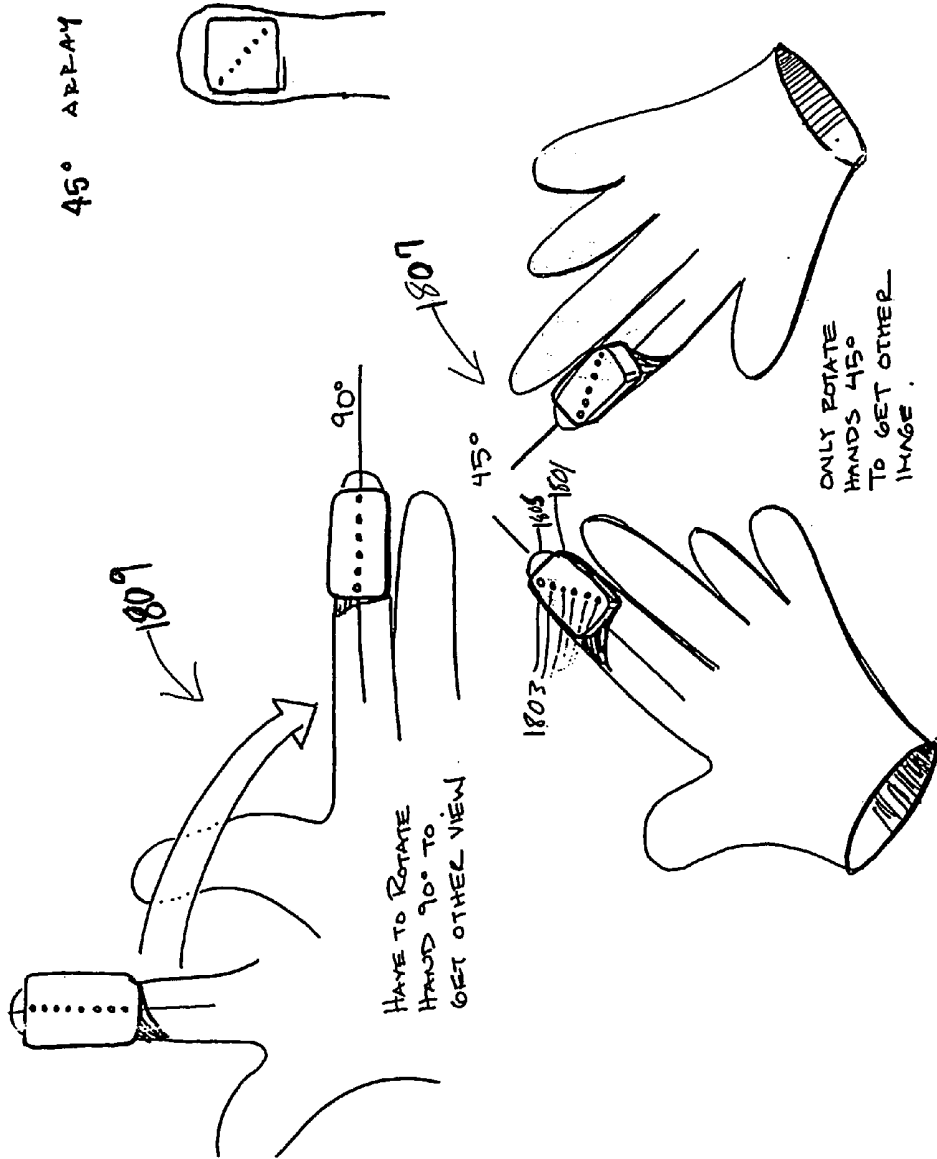

FIG. 23

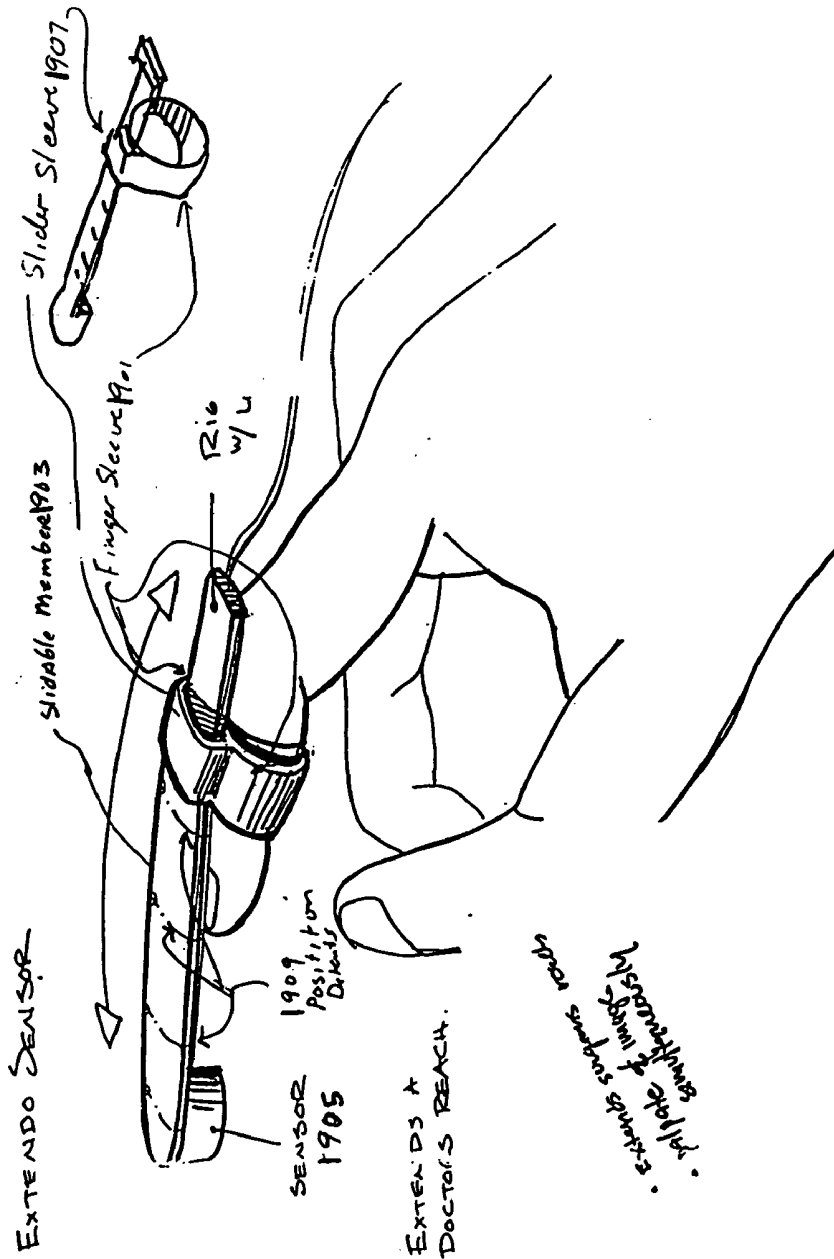

FIG. 24

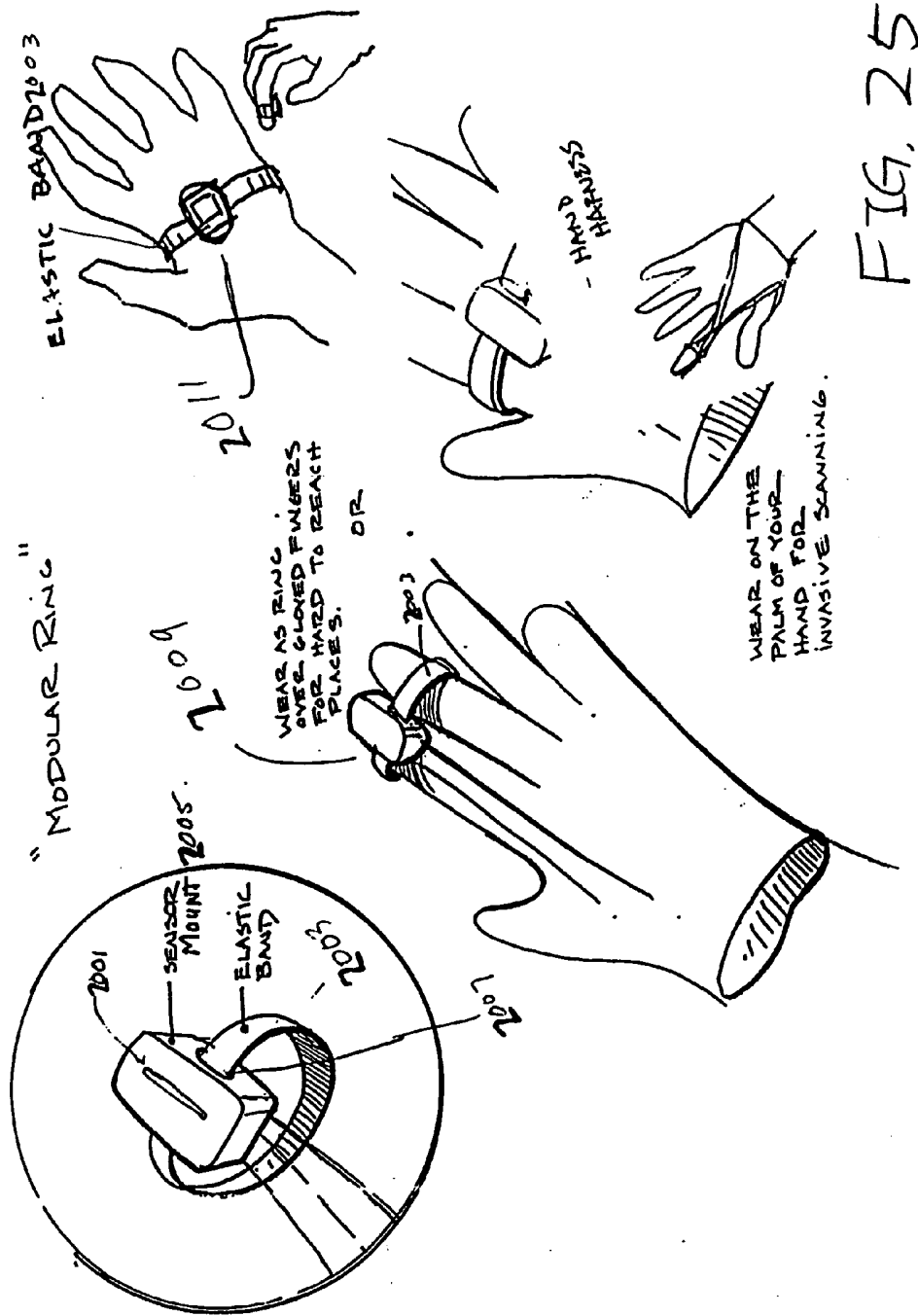

FIG. 25

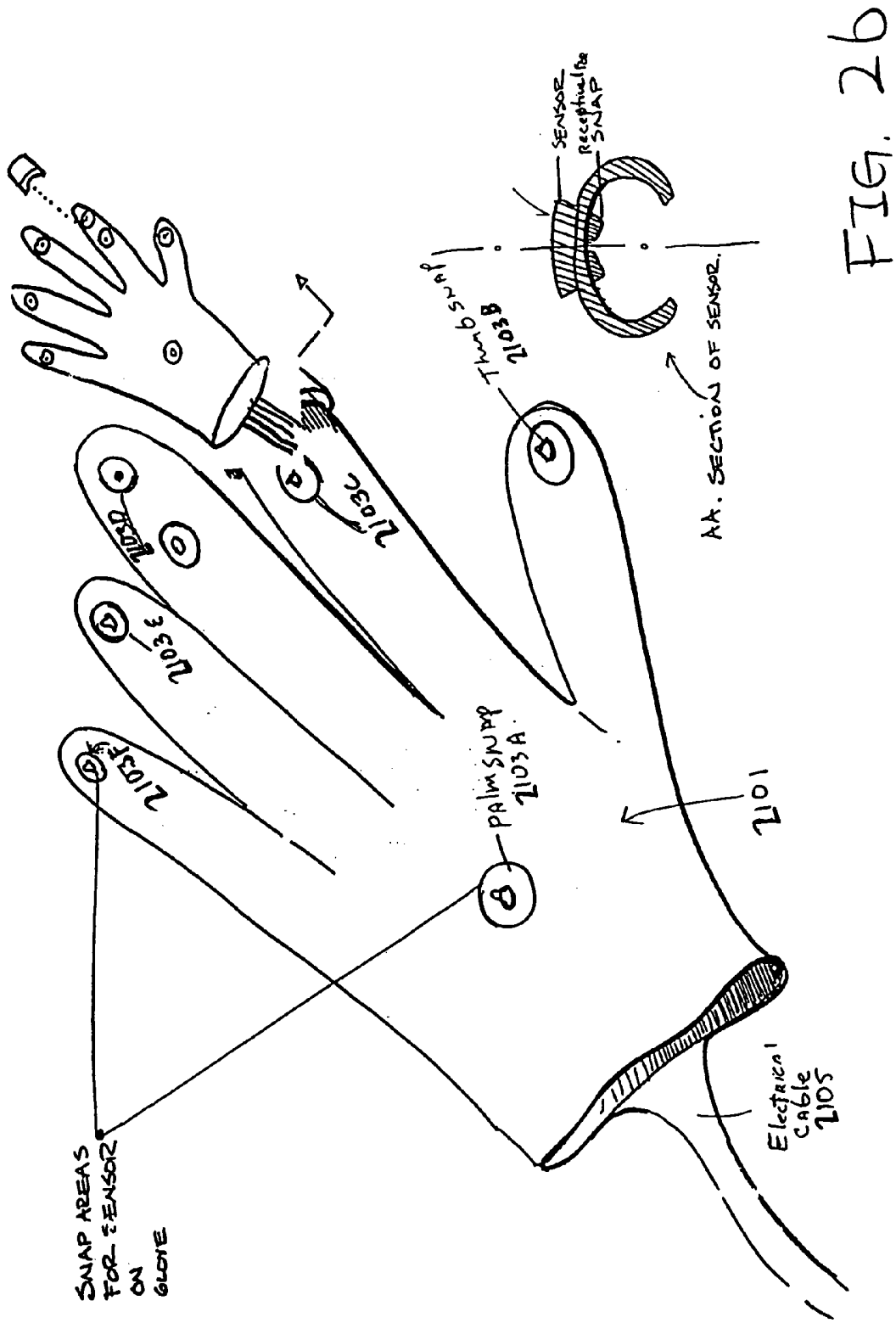

FIG. 26

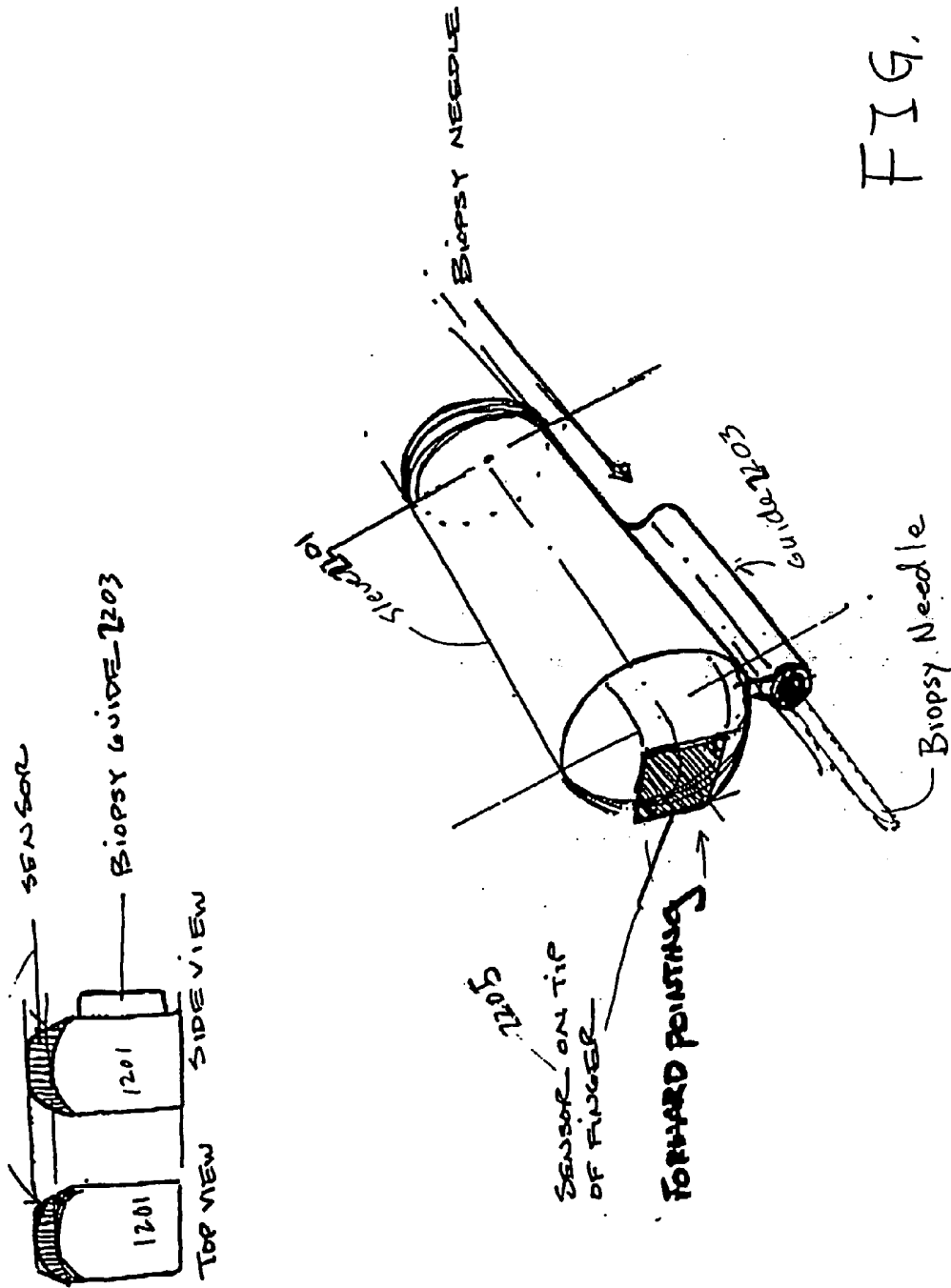

FIG. 27

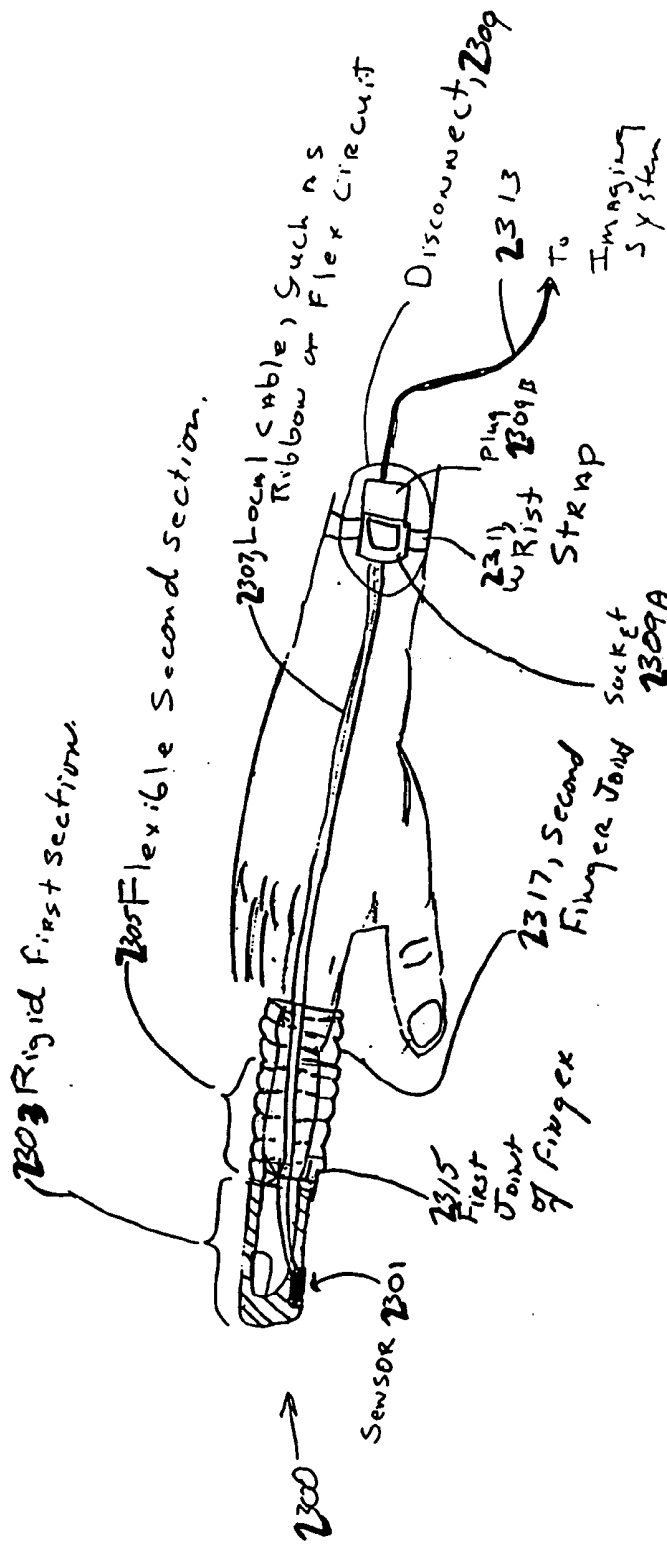

FIG. 28

ACOUSTIC MEDICAL SENSOR FOR ULTRASOUND IMAGING

CROSS-REFERENCE TO RELATED APPLICATION(S)

[0001] This application is a continuation-in-part of U.S. patent application Ser. No. 10/724,382 entitled "Immersible Ultrasound Probe and Cable," filed Nov. 26, 2003, which claims priority to and the benefit of U.S. Provisional Patent Application No. 60/429,614 entitled "Steam Autoclavable Ultrasound Probe Connector," filed Nov. 27, 2002, the entire contents of both of which are incorporated by reference herein.

FIELD OF THE INVENTION

[0002] The present invention is generally directed to medical imaging sensors and more particularly to hand held acoustic sensors that are used to provide physiological data to electronic medical systems. Such hand held acoustic sensors may be sterilized through immersion in a disinfecting liquid and/or steam autoclaving.

BACKGROUND

[0003] Acoustic sensors, hereinafter "acoustic sensor", "sensor" or "sensor array", are commonly ultrasonic sensors and are widely used for diagnosis and medical testing, imaging in invasive procedures, body cavity imaging, use in a cannula, laparoscopic procedures and the like.

[0004] Acoustic sensors have tended to be large bulky and difficult to manipulate. A bulky sensor may make it difficult to maneuver and hence difficult to image the correct tissue plane. Making a sensor smaller however may lead to difficulty in trying to manipulate, maneuver and position the sensor and may be difficult to apply sufficient pressure, in order to achieve a proper acoustic coupling.

[0005] Studies have shown that medical professionals, when using acoustic sensors, commonly manipulate them by creating a stable positioning of the sensor by applying pressure without moving it. Once a stable positioning of the sensor is achieved the medical professionals will then commonly focus on the area of interest by using small movements. Although large sensors are convenient for applying pressure, they tend to be inconvenient for producing small fine movements. The movement of sensors may also be inhibited by the drag of a cable, which attaches a sensor to an imaging system. Such a cable may also impart a torque to the sensor, as it drags behind, making precise manipulation difficult.

[0006] Additionally gripping large sensor with enough pressure to hold them steady may produce hand strain. Another difficulty with sensors is that they may be inconvenient to use. That is, when a sensor is needed for imaging, the sensor must be located. Once the sensor has been used it must be put away so as not to occupy a hand unnecessarily or have the leads coupling the sensor to the imaging equipment get in the way. Accordingly there may be a trade off between having a sensor readily available for use, and being in the way when the sensor is not in use. There is a need in the art for sensors, which are easier to manipulate and position, as well as sensors that do not cause undue strain in gripping. Additionally there is a need for sensors that are

readily available for use by medical professionals, but are easily made unobtrusive when not in use.

[0007] Sensors, because of their electronic components and other reasons, may not be sterilizable by all sterilization techniques. Methods of making sensors more susceptible to sterilization methods are needed.

[0008] Accordingly there is a need in the art for sensors having improved packaging, design and human machine interfaces.

SUMMARY OF THE INVENTION

[0009] Exemplary embodiments of the present invention provide acoustic sensors, which may be manipulated using a medical professional's fingers, and may be used to apply sufficient pressure that a sufficient acoustic coupling may be achieved.

[0010] One embodiment comprises a hand held acoustic sensor apparatus having an hourglass shaped sensor casing. The sensor casing has a top end and a bottom end, with an acoustic sensor mounted at the bottom end of the sensor casing, and an orientation indicator coupled to the top end of the sensor casing such that the orientation indicator indicates the position of the sensor.

[0011] Another embodiment of the invention comprises a hand held acoustic sensor apparatus. The apparatus includes a ring sized to fit on a finger, a track disposed within the circumference of the ring, and a sensor disposed in the track such that the sensor may be rotated with respect to the track.

[0012] Still another embodiment comprises a hand held acoustic sensor apparatus including a fingertip shaped extension. The apparatus also includes a sensor disposed within the fingertip shaped extension, a circular-gripping element that grips a finger; and a lateral member that couples the fingertip shaped extension to the circular gripping element.

[0013] In another embodiment a local disconnect may be used to couple a sensor to a tether cable that couples the sensor to an imaging machine. The local disconnect provides not only a way for disconnecting the cable from the sensor, which may be worn by the medical professional, but also a strain relief preventing a long tether cable from imparting torque to the sensor and making it difficult to manipulate.

[0014] In still other embodiments a flat cable such as a ribbon cable or a flexible circuit cable may be used to couple a sensor to a cable that couples the sensor to an imaging machine.

[0015] A further embodiment comprises a hand held acoustic sensor apparatus having a finger sleeve for gripping a finger. The apparatus also includes a hinge disposed at one end of the finger sleeve, a "U" bracket coupled to the hinge at the upper end; and a sensor coupled to the lower end of the "U" bracket.

[0016] Yet a further embodiment comprises a hand held acoustic sensor apparatus including a closed end tube, having an open end for the insertion of a finger. The apparatus also includes a sensor disposed in the circumference of the tube proximate to the closed end of the tube and a ring. The ring is disposed such that the circumference of the ring is coupled to the circumference of the tube, such that a finger disposed in the ring is essentially parallel to a finger disposed within the tube.

[0017] Still yet another embodiment comprises a hand held acoustic sensor apparatus having an oval shaped pocket. The apparatus also includes an open end and a closed end, the pocket being of sufficient size to house two fingers disposed therein and a sensor disposed on the surface of the pocket.

[0018] Yet another embodiment of the invention comprises a hand held acoustic sensor apparatus including a sensor mount having a flat side. The apparatus also includes a ring, for containing a finger, coupled to the sensor mount. The sensor mount is positioned such that it may be made essentially parallel to a palm of a hand wearing the ring. A plurality of sensors are disposed on the flat side of the sensor mount such that a line connecting the sensors form a forty five degree angle with a finger disposed within the ring.

[0019] Still yet another embodiment comprises a hand held acoustic sensor apparatus including a finger sleeve for wearing on a finger. The apparatus also includes a slot in finger sleeve, a slidable member disposed such that the slidable member has interference fit within the finger sleeve and a sensor disposed at an end of the slidable member such that the sensor extends beyond the finger.

[0020] A still further embodiment comprises a hand held acoustic sensor apparatus includes a sensor mount having a sensor coupled to the mount. The apparatus also includes a slot disposed in the sensor mount and a rubber band disposed in the sensor mount slot.

[0021] Another embodiment comprises a hand held acoustic sensor apparatus that includes a glove having a plurality of snap attachments by which sensors may be attached. The apparatus includes a cable electrically coupled to the snap attachments and a sensor that attaches to at least one of the plurality of snap attachments and makes an electrical connection to the cable.

[0022] Still another embodiment comprises a hand held acoustic sensor apparatus includes a tube having a closed end and an open end for receiving a finger. The apparatus includes a guide tube having both ends open and attached in parallel to the tube having one closed end and a sensor disposed on the closed end of the tube.

[0023] In yet a further embodiment of the invention a sensor is mounted at the end of a tube that is worn over a finger. The tube includes a first portion that covers the first joint of the finger and is rigid. The sensor is disposed within the rigid first portion of the tube. The tube also comprises a second flexible portion, coupled to the first rigid portion. The second portion provides a secure interference fit with the finger, yet allows joints of the finger to freely bend, thereby providing increased mobility over a rigid tube.

BRIEF DESCRIPTION OF THE DRAWINGS

[0024] Features, aspects, and advantages of the present invention will be better understood with regard to the following description and accompanying drawings, in which:

[0025] FIG. 1 is a medical ultrasound system, which includes a finger mounted probe and a sterilizable probe connector in an exemplary embodiment according to the present invention;

[0026] FIGS. 2A-2E illustrate first through fifth exemplary embodiments of probe and cable assemblies according to the present invention;

[0027] FIG. 3 is a PCB assembly of the fifth exemplary embodiment of the present invention;

[0028] FIGS. 4A-4C illustrate a sterilizable connector in exemplary embodiments of the present invention;

[0029] FIGS. 5A-5E illustrate finger mounted probes in exemplary embodiments of the present invention;

[0030] FIGS. 6A-6C illustrate finger mounted probes in one exemplary embodiment of the present invention;

[0031] FIGS. 7A-7B illustrate connection between a wrist connector and a cable connector in an exemplary embodiment of the present invention;

[0032] FIGS. 8A-8C illustrate a process of mounting a sterilizable connector to an adapter in an exemplary embodiment of the present invention;

[0033] FIG. 9 is an exploded view of the adapter of FIGS. 8A-8C;

[0034] FIGS. 10A-10B illustrate a cross sectional side view of the process of mounting the sterilizable connector to the adapter of FIGS. 8A-8C;

[0035] FIG. 11 illustrates a connector assembly in an exemplary embodiment according to the present invention, where a sterilizable connector electrically interfaces with a standard ultrasound equipment connector via a mating connector;

[0036] FIG. 12 is a mating surface view of the sterilizable connector of FIG. 11;

[0037] FIG. 13 is a cross-sectional view of the sterilizable connector of FIG. 11;

[0038] FIG. 14 illustrates a connector assembly in another exemplary embodiment according to the present invention, where a sterilizable connector electrically interfaces with a standard ultrasound equipment connector via a mating connector;

[0039] FIG. 15 illustrates an anisotropic conducting pad that interfaces between the sterilizable connector and mating connector of FIG. 14;

[0040] FIG. 16 is a graphic illustration of the environment in which embodiments of the present invention may be found;

[0041] FIG. 17 is a graphic illustration of an acoustic sensor that may be held between two fingers;

[0042] FIG. 18A is a graphic illustration of an acoustic sensor that may be rotatably worn on a finger;

[0043] FIG. 18B is a graphic illustration of a local connection mechanism as may be used to provide a local disconnect for a finger worn sensor;

[0044] FIG. 19A is a graphic illustration of an acoustic sensor that may be extensibly worn on a finger;

[0045] FIG. 19B enclosures that may be used with finger mounted acoustic sensors in order to enhance the ability to use the sensor in a sterile environment;

[0046] FIG. 20 is a graphic illustration of a flip up acoustic sensor designed to worn on a finger;

[0047] FIG. 21 is a graphic illustration of an acoustic sensor designed to be worn on a finger, having a guidance attachment on an adjoining finger;

[0048] FIG. 22 is a graphic illustration of an acoustic sensor that may be worn over two fingers;

[0049] FIG. 23 is a graphic illustration of an acoustic sensor array that may be worn on one finger;

[0050] FIG. 24 is a graphic illustration of an extensible acoustic sensor that may be worn on one finger;

[0051] FIG. 25 is a graphic illustration of an acoustic sensor that may be secured to a hand by an adjustable elastic band;

[0052] FIG. 26 is a graphic illustration of a snap on acoustic sensor that may be attached to various points on a glove;

[0053] FIG. 27 is a graphic illustration of an acoustic sensor, having an integral needle guide, which may be worn on a finger; and

[0054] FIG. 28 is a graphic illustration of a single finger mounted acoustic sensor.

DETAILED DESCRIPTION OF EMBODIMENTS OF THE INVENTION

[0055] FIG. 1 is a system diagram of a medical ultrasound system 10 in an exemplary embodiment of the present invention. The medical ultrasound system 10 includes an ultrasound platform 12, which provides a user (e.g., a medical technician) with capabilities to generate, process and display ultrasound images using a probe (also referred to as a probe head or an autoclavable probe) 18. The probe 18 includes a sensor assembly (e.g., a transducer assembly) for taking ultrasound images. For example, the probe 18 may be a sterilizable finger mounted probe, and may include an array of ultrasound sensors for ultrasound imaging.

[0056] The probe 18 is coupled to the platform 12 via a cable 16 and a connector assembly 14. The cable 16 should be a multi-wire cable that can carry multiple signals at the same time. The connector assembly 14 includes a sterilizable connector, which may be a large pin count, low insertion force, steam autoclavable connector suitable for medical ultrasound applications.

[0057] The probe 18 may be sterilized, for example, through immersion in a disinfecting liquid and/or steam autoclaving. The sterilizable connector may also be sterilized in a similar manner. The disinfecting liquid, for example, may include Glutaraldehyde (Cidex) and/or Chlorhexidine-gluconate solutions. During steam autoclaving, for example, the probe and the attached connector may be exposed to 206.8 Kpa (kilopascal) (or 30 psi (pound per square inch)) steam for 15 minutes.

[0058] The connector assembly 14 also includes an adapter assembly. The adapter assembly includes a connector (also referred to as a mating connector) to be mated to the sterilizable connector and a connector (also referred to as a standard connector) to be mated to the ultrasound platform (i.e., a standard connector). The standard connector, for

example, can mate to a connector of a standard medical ultrasound system, such that the sterilizable connector of the present invention can be used with conventional medical ultrasound systems. Otherwise, the sterilizable probe attached to the sterilizable connector may not be compatible with existing commercial medical ultrasound systems, thus limiting marketability thereof. The standard connector may be any common ultrasound connector including, but not limited to, DL series of Zero Insertion Force (ZIF) connectors available from ITT Cannon. In other embodiments, the connector assembly 14 may not include an adapter assembly; instead, the sterilizable connector may connect directly with a mating connector on the ultrasound platform 12.

[0059] FIG. 2A-2E illustrate exemplary embodiments of a probe and cable. In each of these exemplary embodiments, the probe is used to provide high frequency sound waves (i.e., ultrasound), which are coupled to an imaging subject across an acoustic seal. The acoustic seal may include a sound conductive gel, which couples the sound waves between the probe and the imaging subject.

[0060] While each of FIGS. 2A-2E illustrates an open-ended finger type probe, in practice, the probes can be close-ended or open-nail ended (in which only the finger nail portion of the probe is open ended), and/or any other suitable probes that are sterilizable through immersion and/or steam autoclaving. In one exemplary embodiment, for example, the probes should withstand at least 1,000 cleaning and sterilization cycles without substantial degradation in performance.

[0061] FIG. 2A illustrates a first exemplary embodiment of a probe and cable assembly 20 in accordance with the present invention. A probe 22 is coupled via a cable 24 to a wrist connector 28 on a cuff mount 25, which can be worn on a wrist of the user. The probe 22, the cable 24, the cuff mount 25 and the wrist connector 28 are immersible in a disinfecting liquid (e.g., Glutaraldehyde (Cidex) and/or Chlorhexidine-gluconate solutions) and/or steam autoclavable for sterilization. The probe 22, for example, is a finger mounted probe. The cable 24, for example, may be formed from a flexible planar circuit.

[0062] The wrist connector 28 can be detachably connected to an ultrasound platform using a cable 30. The cable 30 has a connector 29 for coupling with the wrist connector 28 and a connector 32 for connecting to the ultrasound platform. Since the cable 30 is detachable from the cuff mount 25, the wrist connector 28, the cable 24, and the probe 22, which together may be referred as an immersible probe assembly, the cable 30 is not necessarily sterilizable, e.g., through immersion or steam autoclaving.

[0063] The probe 22 can perhaps be better described in reference to FIG. 5A. The probe 22 has a generally cylindrical finger mount 144, which is shaped for wearing on a finger of the user in much the same manner as a ring. In order to allow different users having different finger sizes to wear a same-sized probe 22, a finger cot 140 that may have varying sizes and thicknesses can be worn over the user's finger first prior to wearing the finger mount 144. The probe 22 also has formed thereon a sensor housing 142 for mounting a sensor assembly therein. Probes in the exemplary embodiments of FIGS. 2C-2E may also have a configuration that is substantially the same as the configuration of probe 22.

[0064] In one exemplary embodiment, the sensor assembly, for example, may include an array of 96 sensors (i.e., transducers) having a pitch of about 4 mils (i.e., approximately 101.6 micro meters), an elevation focus of 35 millimeter (mm) radius and an elevation of 6 mm. The sensor assembly may be for operation at 5 mega Hertz (MHz) or 7.5 MHz, or any other suitable frequency. The acoustic frequency may be 6+ MHz with a -6 dB bandwidth greater than 40%. The impedance of the sensor array may be between approximately 400 and approximately 700 ohms over approximately 4.5 to approximately 9 MHz.

[0065] FIG. 6A illustrates a probe 200 that can be used instead of the probe 22 or the probes in FIGS. 2C-2E. The probe 200 has an outer housing 202, which has a hemispherical tip 203 and a generally cylindrical section 204. The hemispherical tip 203 and the generally cylindrical section 204 define an elongated cavity through which a finger of a user can be inserted. The open end of the generally cylindrical section 204 has a circular cross-section whose radius is larger than that of the circular cross-section of the end abutting the hemispherical tip 203.

[0066] On the outer surface of the generally cylindrical section 204 is formed thereon a sensor housing 206 for mounting a sensor therein. The sensor housing 206 has a substantially rectangular block shape, and has an opening 207 at the bottom (i.e., side opposite the side attached to the cylindrical section 204) for emitting ultrasound waves, and for sensing the reflected ultrasound waves for imaging. A finger cot 205 having various different sizes and thicknesses may be worn on the finger before wearing the probe 200, such that users having various different finger sizes may use a one-size-fits-all probe.

[0067] FIGS. 6B and 6C illustrate, respectively, a cross-sectional view of the probe 200 and the components inside the outer housing 202 of the probe 200. The flexible circuit 208 has attached at the probe end a bow-shaped flexible circuit section 209 that wraps about half way around the inner housing 211. The flexible circuit 208 may also include two overlaid flexible circuits that are substantially parallel to each other. Each of the two overlaid flexible circuits may include the bow-shaped flexible circuit, which together may wrap around the inner housing 211 with a cross-section of an ellipse or a circle.

[0068] The inner housing 211 has attached thereto two brackets 210 and 212 for holding the sensor assembly 214. The brackets 210, 212 and the sensor assembly 214 are substantially contained inside the sensor housing 206. The sensor housing 206 has the opening 207 at the bottom for exposing the sensor array of the sensor assembly 214 for ultrasound imaging. The inner and outer housings should be sealed together such that moisture cannot enter between the inner and outer housings during sterilization (e.g., immersion in a disinfecting liquid and/or steam autoclaving). The sensor housing 206 should also be sealed to prevent moisture from entering the housing 200 between the opening 207 and the sensor assembly 214. The sensor housing 206, for example, may be sealed by suitable adhesive and/or through overmolding the assembly.

[0069] FIGS. 5A to 6C illustrate finger probes having non-rotated sensor arrays. In other words, the sensor array is pointing straight down, where its surface is substantially parallel to the surface of the finger portion on which the

finger probe is mounted. In other embodiments, the sensor array may be constructed so as to face forward or backward by angles of 10 degrees, 20 degrees, and so on. Using a finger probe with a rotated sensor array, portions of a human body can be imaged at a different angle without re-orienting the finger wearing the finger probe.

[0070] FIG. 2B illustrates a second exemplary embodiment of a probe and cable assembly 40 in accordance with the present invention. A probe 42 is coupled via a cable 46 to a sterilizable connector 48. The sterilizable connector 48 interfaces with a cable 52 via a connector 50. At the other end of the cable 52 is a connector 54, which may be a standard connector for connecting to a ultrasound medical platform. The probe 42, for example, is a finger mounted probe. The probe 42, the cable 46 and the connector 48 are sterilizable, for example, through immersion in a disinfecting liquid (e.g., Glutaraldehyde (Cidex) and/or Chlorohexidine-gluconate solutions) and/or steam autoclaving. The cable 52 and its connectors 50 and 54 can be detached from the sterilizable connector 48, and are not necessarily sterilizable.

[0071] The sterilizable connector 48 may be mounted on a belt or at the back of a user such that the user can easily unplug the immersible sub-assembly including the probe 42, the cable 46 and the sterilizable connector 48 from the cable 52, and at the same time not be encumbered by the loose end of the cable 46. The probe 42 may be attached to the cable 46 via a molded finger probe strain reliever such that the electrical connection between the probe 42 and the cable 46 is not damaged through the strain between the probe 42 and the cable 46.

[0072] The probe 42 can perhaps be better described in reference to FIG. 5B. The probe 42 has a generally cylindrical finger mount 154, which is shaped for wearing on a finger of the user in much the same manner as a ring. In order to allow different users having different finger sizes to wear a same-sized probe 42, a finger cot 150 that may have varying sizes and thicknesses can be worn over the user's finger first prior to wearing the finger mount 154. The probe 42 also has formed thereon a sensor housing 152 for mounting a sensor assembly therein. Unlike the probe 22 of FIG. 5A, the probe 42 has integrated (e.g., through molding) to the finger mount 154 a strain reliever 156, which is used to relieve strain in the electrical connections between the probe 42 and the cable 46. Similar strain relievers may also be used with the probe 22 and other probes.

[0073] FIG. 2C illustrates a third exemplary embodiment of a probe and cable assembly 60 in accordance with the present invention. A probe 62 is coupled via a cable 64 to a wrist connector 68 on a cuff mount 65, which can be worn on a wrist of the user. The probe 62, the cable 64, the cuff mount 65 and the wrist connector 68 are immersible in a disinfecting liquid (e.g., Glutaraldehyde (Cidex) and/or Chlorohexidine-gluconate solutions) and/or steam autoclavable for sterilization. The probe 62, for example, is a finger mounted probe. The cable 64, for example, may be formed from a flexible planar circuit.

[0074] The wrist connector 68 can be detachably connected to an ultrasound platform using a cable 70. The cable 70 has a connector 69 for coupling with the wrist connector 68 and a connector 72 for connecting to the ultrasound platform through an adapter 74. Since the cable 70 is

detachable from the cuff mount **65**, the wrist connector **68**, the cable **64**, and the probe **62**, which together may be referred to as an immersible probe assembly, the cable **70** is not necessarily sterilizable, e.g., through immersion and/or steam autoclaving. However, as the cable **70** is electrically connected to the ultrasound platform through the adapter **74**, the connector **72** is not necessarily a standard ultrasound equipment connector, and can be a steam autoclavable connector. Therefore, the cable **70** and its connectors **69** and **72** may also be sterilizable through immersion in a disinfecting liquid and/or steam autoclaving.

[0075] FIG. 2D illustrates a fourth exemplary embodiment of a probe and cable assembly **80** in accordance with the present invention. A probe **82** is coupled via a cable **84** to a wrist connector **88** on a cuff mount **85**, which can be worn on a wrist of the user. The probe **82**, the cable **84**, the cuff mount **85** and the wrist connector **88** are immersible in a disinfecting liquid (e.g., Glutaraldehyde (Cidex) and/or Chlorhexidine-gluconate solutions) and/or steam autoclavable for sterilization. The probe **82**, for example, is a finger mounted probe. The cable **84**, for example, may be formed from a flexible planar circuit.

[0076] The wrist connector **88** can be detachably connected to an ultrasound platform through cables **90** and **96**. The cable **90** has a connector **89** for coupling with the wrist connector **88** and a connector **92** for connecting to the ultrasound platform through the cable **96**. The cable **96** has a connector **98** (e.g., a standard ultrasound equipment connector) for electrically connecting to the ultrasound platform, and a connector **94** for connecting With the connector **92** of the cable **90**.

[0077] Since the cables **90** and **96** are detachable from the cuff mount **85**, the wrist connector **88**, the cable **84**, and the probe **82**, which together may be referred to as an immersible probe assembly, the cables **90** and **96** are not necessarily sterilizable, e.g., through immersion and/or steam autoclaving. However, as the cable **90** is electrically connected to the ultrasound platform through the detachable cable **96**, the connector **92** is not necessarily a standard ultrasound equipment connector, and can be a steam autoclavable connector. Therefore, the cable **90** and its connectors **89** and **92** may also be sterilizable through immersion in a disinfecting liquid and/or steam autoclaving.

[0078] FIG. 2E illustrates a fifth exemplary embodiment of probe and cable assembly **100** in accordance with the present invention. The probe and cable assembly **100** is similar in configuration as the probe and cable assembly **60** of FIG. 2C, except that the probe and cable assembly **100** does not have a wrist connector and it is made of a single immersible probe assembly whose components cannot be easily detached from each other. Also, a probe **102** is shown without a removable finger cot for inserting a finger fitably into the probe. In addition, the probe **102** shows a sensor housing **104** for holding a sensor assembly, which is attached thereto. In practice, all the probes of FIGS. 2A-2D each have a similar sensor housing.

[0079] The probe **102** is coupled via a cable **106** to a printed circuit board (PCB) assembly **108**. The PCB assembly **108** is connected to a sterilizable connector **112** via a cable **110**. Since the PCB assembly **108** is not readily detachable from the cable **110** in the fifth exemplary embodiment, all of the probe **102**, the cable **106**, the PCB

assembly **108**, the cable **110** and the connector **112** are immersible in a disinfecting liquid (e.g., Glutaraldehyde (Cidex) and/or Chlorhexidine-gluconate solutions) and/or steam autoclavable for sterilization. The cable **106**, for example, may be formed from a flexible planar circuit. Since the connector **112** is not a standard ultrasound equipment connector, it interfaces with an ultrasound platform via an adapter (or alternatively, via another cable).

[0080] FIG. 5C-5E show the probe **102** of the probe and cable assembly **100** of FIG. 2E. The probe **102** may be substantially the same as the probe **22** of FIG. 5A, and may also be used in the exemplary embodiments of FIGS. 2A, 2C and 2D. The probe **102** has a generally cylindrical outer housing **103** and the sensor housing **104** attached thereto. A sensor assembly **117** is mounted inside the sensor housing **104**. The sensor assembly **117** has a generally rectangular cross-section, and has at its bottom surface a sensor array **119** (i.e., transducer array) for ultrasound imaging. The sensor housing **104** has a generally rectangular opening for allowing the sensor array **119** to be exposed.

[0081] Disposed within the outer housing **103** is an inner housing **111**. The inner housing **111** also has a generally cylindrical shape, and fits substantially tightly within the outer housing **103**. The inner housing **111** has attached thereto brackets **116** and **118** for holding the sensor assembly **117**. The brackets **116** and **118** as well as the sensor assembly **117** fit substantially within the sensor housing **104**.

[0082] The inner and outer housings should be sealed together such that moisture cannot enter between the inner and outer housings during sterilization (e.g., immersion in a disinfecting liquid and/or steam autoclaving). Further, the sensor housing **104** should be sealed such that moisture does not enter into the housing between the sensor assembly **117** and the periphery of the opening at the bottom. The probes **22** and **42** of FIGS. 2A, 5A, 2B, 5B, respectively, should be sealed in a similar manner.

[0083] As shown in FIG. 5E, the flexible circuit **106** includes two flat flexible circuits **112** and **114** that are substantially parallel to each other. The flexible circuit **112** is overlaid on top of the flexible circuit **114** through most of the length of the flexible circuit **106**. One end of the flexible circuit **106** is terminated to a PCB **120** as shown in FIG. 3. The other end of the flexible circuit **106** has attached thereto a pair of bow-shaped flexible circuit sections **113** and **115**. The two flexible circuit sections **113** and **115** together form an elliptical section that fits between the inner housing **111** and the outer housing **103**. The flexible circuit section **113** at its top end is electrically connected to the flexible circuit **114**, whereas the flexible circuit section **115** at its top end is electrically connected to the flexible circuit **112**. Both the flexible circuit sections **113** and **115** terminate at the sensor assembly **117** at their respective bottom ends.

[0084] In other embodiments, the probe inner/outer housing may have various different shapes suitable for mounting on a finger. For example, the inner and/or outer housing may not encircle the finger completely, but may only partially envelope the finger with an opening at the top. The inner and/or outer housing may also envelope the end of the finger similar to the probe **200** of FIGS. 6A-6C, except for an opening near its front edge to expose only a finger nail portion (or a part thereof) of the finger.

[0085] FIG. 3 illustrates the PCB assembly **108** of FIG. 2E. The PCB assembly **108** includes a PCB **120** (shown in

phantom lines) encased in a PCB housing 126. The PCB assembly 108 may also be referred to as a wrist adapter, and the PCB housing 126 may be referred to as a wrist adapter over mold. The cable 106 is electrically coupled to the PCB 120 at terminations 122 (shown in phantom lines), whereas the cable 110 is electrically coupled to the PCB 120 at terminations 124 (shown in phantom lines). This way, electrical connections can be made between the cables 106 and 110. The PCB housing 126 also has strain relievers 127 and 128 formed thereon for engaging the ends of the cables 106 and 110, respectively, so as to relieve strain to the electrical connections between the PCB 120 and the cables 106 and 110.

[0086] FIG. 4A is a perspective view of the sterilizable connector 112 at the other end of the cable 110. The sterilizable connector 112 can be sterilized through steam autoclaving. In other embodiments, the sterilizable connector 112 may be sterilized through immersion, for example, in a disinfecting liquid. As can be seen in FIGS. 4A-C, the sterilizable connector 112 has a connector housing 130 for fixedly holding a flexible circuit 131 and a flexible circuit support 132. The connector housing 130 also has formed thereon a strain reliever 135 for relieving strain in electrical connections between the flexible circuit 131 and the cable 110.

[0087] The flexible circuit support 132 is formed of two support pieces that are substantially perpendicular to one another. The first (substantially square shaped) support piece is parallel to the interface surface of the connector 112. The second (substantially rectangular) support piece is mounted on the first support piece on the other side of the interface surface. The support pieces are attached together through plug-and-hole type connections, pins, or any other suitable fastening mechanism.

[0088] The flexible circuit 131 may be made of a number of connected folded portions for wrapping around the first support piece and covering most of the second support piece on both sides. For example, the flexible circuit 131 includes end portions 170 (e.g., overlaid on each side of the second support piece), a rear surface portion 176 (overlaid on the rear surface of the first support piece), intermediate portions 172 and 174 (e.g., overlaid on the back surface portion 176), an upper edge portion 178 and a front surface portion 180 (which forms the interface surface of the connector 112). The back surface portion 176 of the flexible circuit between the two support pieces may have holes formed thereon to allow the two support pieces to be attached together there-through.

[0089] The connector housing 130 has a generally cubical shape with one end bigger than the other end. Between the bigger and smaller ends are concave sections 129 that are formed for ease of holding by a user for plugging/unplugging the connector to an adapter. The strain reliever 135 extends downward from a bottom surface of the connector housing 130.

[0090] The bigger end (i.e., an interface surface) of the connector housing 130 has exposed thereon the front surface portion 180 of the flexible circuit 131. On the front surface portion 180 has formed thereon multiple contacts 133 for electrically interfacing with the contacts on an adapter. In one exemplary embodiment, there are approximately 200 contacts on the flexible circuit 131. In other exemplary

embodiments the number of contacts may range from 200 to 500. In still other exemplary embodiments, less than 200 or more than 500 contacts may be used. The front surface portion 180 and the contacts 133 formed thereon are surrounded by a frame 139 that encircle the periphery of the interface surface of the connector housing 130 except for an opening 137 at the top.

[0091] Left and right edges of the frame 139 are formed as convex protrusions 134, each of which has a shape of a tip of a circle formed by cutting the circle with a vertical chord. Inner edges 136 of the frame 139 that correspond to the convex protrusions 134 also have a similar shape. An upper edge of the front surface portion 180 is adjacent to the opening 137 of the frame 139 at the top of the connector housing 130. However, a lower edge of the front surface portion 180 is farther away from the bottom inner edge of the frame 139, thereby leaving an exposed area 138 of the interface surface that is not overlaid by the front surface portion 180. The exposed area 138 has a general shape of an upside down pentagon (i.e., with the tip pointing down), which has been elongated in a horizontal direction.

[0092] FIGS. 7A and 7B illustrate the wrist connector 28 and the interaction between the wrist connector 28 and the cable connector 29. The wrist connector 28 can be mounted on a human arm 26 using the cuff mount 25. The cuff mount 25 is hingedly coupled to the wrist connector 28 such that it can be opened or closed with respect to the arm 26. In other embodiments, the wrist connector 28 may be mounted on the human arm 26 using any other suitable mechanism. Attached to the cable connector 29 is a strain reliever 220 for relieving the strain in electrical connections between the cable connector 29 and the cable 30.

[0093] The wrist connector 28 has a generally rectangular lower portion 222 coupled to the cuff mount 25 and a generally circular upper portion 224 that protrudes upward from the lower portion 222. The wrist connector 29 has formed thereon a contact surface 226 having a plurality of contacts 227. On the periphery of the generally circular portion 224 are non-engaging portions 229 and 233 that are located at substantially 180 degrees of each other. A curved engaging protrusion 228 is formed on the periphery portion adjacent to the non-engaging portion 229. In addition, a curved engaging protrusion 232 is formed on the periphery portion adjacent to the non-engaging portion 233. The curved engaging protrusions 228 and 232 are also located at substantially 180 degrees of each other. Rotation stops 225 and 238 are also formed on the periphery of the generally circular portion 224. The rotation stop 225 is aligned with the flexible circuit 24. The rotation stop 238 is located at substantially 180 degrees from the rotation stop 225.

[0094] The cable connector 29 has formed thereon a curved peripheral wall 242 attached adjacently to the strain reliever 220. The connector 29 has also formed thereon another curved peripheral wall (not shown) located substantially 180 degrees from the curved peripheral wall 242. Adjacent to the peripheral wall 242 is a non-walled portion 234. A similar non-walled portion (not shown) is located substantially 180 degrees from the non-walled portion 234. On the inside periphery of a portion of the curved peripheral wall 242 is formed a curved protrusion (not shown). In addition, there is another curved protrusion located on said another curved peripheral wall at substantially 180 degrees from the curved protrusion of the peripheral wall 242.

[0095] The cable connector 29 has also formed thereon a contact surface 236 having a plurality of electrical contacts that are aligned with the electrical contacts 227 of the wrist connector during normal operation. An anisotropic contact pad (i.e., z-axis conductive pad) 230 is placed between the contact surfaces 226 and 236 such that as the contact surfaces are brought close together, multiple thin parallel wires between the electrical contacts in the contact pad 230 are deformed (see FIG. 15, for example), and electrical connections are made between corresponding electrical contacts.

[0096] When the cable connector 29 is initially mounted on the wrist connector 28, it is at an angle where the cable is not aligned with the arm 26 of the user. This way, the curved protrusions on the cable connector 29 are aligned with the non-engaging portions 229 and 233, respectively, of the wrist connector 28, and the curved engaging protrusions 228 and 232 on the wrist connector 28, respectively, are aligned with the portions of the curved peripheral walls of the cable connector 29 that do not have the curved protrusions.

[0097] Upon initial mounting, the cable connector is rotated to lock with the wrist connector 28. The rotation of the cable connector 29, for example, may be stopped by the rotation stops 225 and/or 228. The curved engaging protrusions 228 and 232 on the wrist connector 28 and/or the curved protrusions on the cable connector 29 may be slanted (e.g., spiraling) such that the cable connector is brought closer to the wrist connector as the curved protrusions engage and slide with respect to one another. In other embodiments, any other suitable locking mechanism may be used to lock the cable connector 29 to the wrist connector 28. The wrist connector 28 is immersible in a disinfecting liquid and/or steam autoclavable such that it can be sterilized. Steam autoclavable/immersible connectors in other exemplary embodiments are discussed below in reference to FIGS. 11-15.

[0098] FIGS. 8A-8C, 9 and 10A-10B illustrate an adapter 400 that interfaces between the steam autoclavable connector 112 and a ultrasound platform 390. The adapter 400 includes an adapter housing 403, on which a standard ultrasound equipment connector 413 is mounted for mating with an equipment connector 401 on the ultrasound platform 390.

[0099] In one exemplary embodiment, the standard ultrasound equipment connector 413 (and therefore the adapter 400) is mated with the equipment connector 401 using a toggle latch assembly 402. The toggle latch assembly 402 is a standard component on existing ultrasound connectors, and includes a main shaft 422 that goes through the entire body of the connector (through the adapter 402 in this case). At one end is a teardrop shaped handle that may be referred to as a toggle latch 425. At the other end is a short shaft (not shown) that goes through the main shaft 422 at substantially a right angle, thereby forming a cross-shape "key" at the end.

[0100] In operation, the adapter 400 (including the standard ultrasound equipment connector 413) is pushed into its mate (the equipment connector 401) and the cross-shaped key fits into a slot in the equipment connector 401. As the main shaft 422 is rotated using the toggle latch 425, the key engages the equipment connector 401, thereby bringing the

adapter 400 and the mating connector 401 closer together. At approximately 90 degrees of rotation, the key locks into place. To disengage the two mating connectors, the process is simply reversed.

[0101] The toggle latch assembly described above is known to those skilled in the art. Those skilled in the art would also appreciate that the short shaft for forming the "key" may be replaced by other shaped components, and the selection of the "key" is based on the type of ultrasound platform used. In addition, any other mating/locking mechanism known to those skilled in the art may be used instead of the toggle latch assembly to mate the adapter to the ultrasound platform as long as such mating/locking mechanism is supported by the ultrasound platform.

[0102] The adapter 400 also includes an alignment frame 404, an adapter probe mate 406, a backing plate 405 and a shuttle rear plate 411. The adapter probe mate 406 has a plurality of contacts 410 formed thereon. These contacts 410 correspond to and are for forming electrical connections with the contacts 133 of the sterilizable connector 112 via an anisotropic contact pad 408 (i.e., z-axis conductive pad). The contacts 410 are electrically connected to an adapter flexible circuit 420 that are electrically connected through the connector 413 to the equipment connector 401.

[0103] The alignment frame 404 includes a wider opening 424 and a narrower opening 434. The probe mate 406 also has a corresponding wider region 427 and a narrower region 429. The sides of the wider opening 424 and the wider region 427 are shaped to match the convex protrusions 134 of the sterilizable connector 112. Therefore, the sterilizable connector 112 can initially be mated via the contact pad 408 with the wider region 427 of the adapter probe mate 406 through the wider opening 424. The narrower opening 434 has formed along its side peripheries vertical protrusions 440.

[0104] The adapter probe mate 406 is mounted on the shuttle rear plate 411 through an opening 442 on the adapter housing 403. The adapter probe mate 406 and the shuttle rear plate 411 are slidably mounted on the adapter housing 403 such that they can together slide up and down.

[0105] As can be seen in FIG. 8A, the sterilizable connector 112 is first aligned with the wider opening 424 of the alignment frame 404 and the wider region 427 of the adapter probe mate 406. Then, as seen in FIGS. 8B and 10A, the sterilizable connector 112 is mated with the adapter probe mate 406 via the contact pad 408 through the wider opening 424. The adapter 400 at this point is already mated with the equipment connector 401 using the toggle latch assembly 402.

[0106] As can be seen in FIGS. 8C and 10B, after the contact is made, the sterilizable connector 112 is slid down with respect to the adapter housing 403. Along with the sterilizable connector, the adapter probe mate 406 and the shuttle rear plate 411 are also slid down. The alignment frame 404, however, remains stationary with respect to the adapter housing 403. Since the narrower opening 434 has formed along its side peripheries vertical protrusions 440, as the sterilizable connector 112 is slid down, the convex protrusions 134 are pinned under the vertical protrusions 440, such that the sterilizable connector 112 is tightly coupled to the adapter probe mate 406.

[0107] As the contact surfaces are brought close together, multiple thin parallel wires between the electrical contacts in the contact pad 408 are deformed (see FIG. 15, for example), and electrical connections are made between corresponding electrical contacts. This way, the contact pad 408 electrically connects the contacts 133 with the contacts 410.

[0108] FIG. 11 illustrates a connector assembly in an exemplary embodiment according to the present invention, where a sterilizable connector 500 interfaces with an adapter assembly 502, which includes a standard ultrasound equipment connector 514 and a mating connector 510. The connector assembly of FIG. 11, for example, can be used as the connector assembly 14 of FIG. 1. Since the adapter assembly 502 can be coupled and de-coupled with the sterilizable connector 500, it may not need to be sterilizable. The sterilizable connector 500 interfaces with the standard ultrasound equipment connector 514 via the mating connector 510. The mating connector 510 may also be referred to as an adapter.

[0109] As discussed above, in other embodiments, the mating connector 510 may be mounted on the ultrasound platform instead of interfacing with the standard ultrasound equipment connector 514. In these embodiments, the sterilizable connector 500 can be connected directly to the ultrasound platform.

[0110] The sterilizable connector 500 includes multiple electrical contacts 506 mounted thereon to electrically interface with mating contacts 512 on the mating connector 510. The sterilizable connector 500 includes a flexible printed wiring board that is molded into a probe connector housing 504. This provides for an inexpensive and rugged design that, due to its integrated one-piece design, is autoclavable (i.e., steam sterilizable). A cable 508 (also referred to as a probe connector cable or a probe cable) should also be sealed at one end to and within the probe connector housing 504 so that steam sterilization does not damage the sterilizable connector 500 by introducing moisture into it. The cable 508 should be a multi-wire cable that can conduct various different signals between the ultrasound platform 12 and the probe 18.

[0111] When electrical connections are made between the sterilizable connector 500 and the adapter assembly 502, they are held in place, for example, using a locking mechanism known to those skilled in the art. The locking mechanism may include rotate-and-lock mechanism, slide-and-lock mechanism and/or any other suitable locking mechanism for tightly coupling two electrical contact surfaces together, and is used to ensure good electrical contacts between the electrical contacts 506 and the mating contacts 512.

[0112] FIG. 12 illustrates a mating surface view of the sterilizable connector 500. As seen in FIG. 12, the sterilizable connector includes a printed wiring board (i.e., flexible circuit or printed wiring substrate) 520 molded in the probe connector housing 504. The printed wiring board 520 has formed thereon a number of wires 522 (e.g., wire traces) for carrying various different electrical signals and/or to provide power and ground. The printed wires 522, for example, are electrically coupled to the electrical contacts 506.

[0113] As seen in FIG. 13, the sterilizable connector 500 includes the printed wiring board 520, the cable 508, and a

backing 530 that are molded together in the probe connector housing 504. The sterilizable connector 500 also includes contacts 532 for connecting the printed wiring board 520 to the cable 508.

[0114] The materials used to construct the sterilizable connector 500 should be selected such that a seamless, hermetic bond between the components can be formed. Further, a chemical bond may also be formed between the components. Such construction should avoid even the smallest of cracks or seams in which pathogens can survive. The materials should also be selected such that the probe connector housing 504 will survive repeated autoclaving cycles without losing its hermetic seal or mechanical integrity. The probe connector housing 504, for example, may be made of polymer.

[0115] All external material (for all the probes and connectors of the present invention) that may come into contact with human body should be FDA certified. Those skilled in the art would know how to select FDA certified materials that meet requirements for fabricating the probes and the sterilizable connectors of the present invention.

[0116] The electrical contacts 506 in the exemplary embodiment may also be referred to as gold contacts or gold bumps when it is formed by plating a relatively thick gold layer over printed wiring (e.g., copper wiring) 522 of the flexible printed wiring board 520 (i.e., flexible circuit). The gold contacts are selected for the exemplary embodiment because of at least the following properties. Pure gold is a soft, highly conductive and low reactivity metal. The high conductivity and softness provide for an excellent low contact force electrical connection. The low reactivity should ensure that the contact surface will not be adversely affected by harsh environmental conditions (such as encountered during autoclaving).

[0117] As discussed above, the autoclavable connector is realized through the use of gold plated contacts on a unitized molded connector in the described exemplary embodiment. Another notable feature of the described exemplary embodiment is the properties of the backing 530 for the flexible printed wiring board 520. The backing 530 should be selected to have appropriate compliance to allow motion between the mating (or contact) surfaces (i.e., electrical contacts 506 and the mating contacts 512) as the connection is made. In addition, the backing 530 should provide a spring force to keep the two surfaces in contact. Further, a relative motion between the mating surfaces provides a mechanism for removing contaminants between the mating surfaces, thereby allowing a reliable electrical connection between the electrical contacts and the mating contacts.

[0118] FIG. 14 illustrates a connector assembly in another exemplary embodiment according to the present invention, where a sterilizable connector 600 interfaces with an adapter assembly 202, which includes a mating connector 622 and a standard ultrasound equipment connector (also referred to as a standard connector) 620. A cable 606 (which may be multi-wire) is connected to connector sections 604 and 608 of the sterilizable connector 600. In other embodiments, the connector sections 604 and 608 may be a single integrated component. The connector assembly of FIG. 14, for example, may be used as the connector assembly 14 coupled to the ultrasound platform 12 of FIG. 1.

[0119] As discussed above, in other embodiments, the mating connector 622 may be mounted on the ultrasound

platform instead of interfacing with the standard ultrasound equipment connector **620**. In these embodiments, the sterilizable connector **600** can be connected directly to the ultrasound platform.

[0120] The connector assembly of **FIG. 14** may be said to incorporate a “contact pad” design, in which anisotropic conducting contact pads (i.e., z-axis conductive pads) **614**, **616** (also referred to as contact pads) are used, respectively, to make the electrical connection between sterilizable connector’s contacts **610**, **612** and mating connector’s contacts **624**, **626**. Using the “contact pad” design, the connector contacts can be made out of a hard, electrically conductive material and yet have reliable electrical connection using relatively low forces to mate the connectors. Use of the “contact pad” design, therefore should provide a significant increase in connector lifetime. In addition, using removable contact pads may simplify cleaning of the adapter assembly **602** since the contact pads **614** and **616** may be disposable. Further, the contact pads **614** and **616** are deformable, and should be able to provide the contaminant removing mechanical motion and spring force.

[0121] When electrical connections are made between the sterilizable connector **600** and the adapter assembly **602**, they are held in place, for example, using a locking mechanism known to those skilled in the art. The locking mechanism may include rotate-and-lock mechanism, slide-and-lock mechanism and/or any other suitable locking mechanism for tightly coupling two electrical contact surfaces together, and is used to ensure good electrical contacts between the contacts **610** and **624** using the contact pad **614**, and between the contacts **612** and **626** using the contact pad **616**.

[0122] **FIG. 15** illustrates the anisotropic conducting contact pad **614** that interfaces between the sterilizable connector **608** and the mating connector **622**. The contact pad **616** has substantially the same configuration and usage as the contact pad **614**. As seen in **FIG. 15**, the contact pad **614** includes multiple thin parallel wires **630** that are imbedded in a compliant polymer matrix **634**. The polymer matrix **634** serves to insulate each wire as well as to provide suitable compliant mechanical support. The resultant structure should conduct electrical current in only one direction, hence the thin parallel wires **630** function as anisotropic conductors.

[0123] Due to their anisotropic conductive nature, the contact pads **614** and **616** can be used to connect multiple sets of contact surfaces without shorting adjacent conductive contacts. In other words, the polymer matrix **634** prevents the embedded wires from touching each other so as to prevent shorts between them. Further, the compression due to mating forces causes the connecting wires to deform to deformed wires **632**. This motion serves to remove surface contaminants, thereby permitting a reliable electrical contact. The polymer matrix **634** should be selected such that it provides the necessary spring force to keep the deformed wires **632** in constant contact with the electrical contact surfaces.

[0124] The anisotropic conducting contact pads (or contact pads) are typically used to provide low-insertion-force, multi-contact connections between high value and/or fragile electronic components and a mating connector. The advantage of this connector system is the ability to make

extremely dense, large quantity, reliable, very low force electrical connections. The anisotropic conducting contact pads may be disposable. The general use of the anisotropic conducting contact pads and the selection of suitable polymer matrix are known to those skilled in the art.

[0125] In this exemplary embodiment, the use of the contact pads allows the use of a hard contact surface between the two mating connectors. Hard contact surfaces reduce the scratching and pitting in the contacts seen in traditional gold contact designs. Such pitting may provide a safe haven for pathological agents. These agents could be chemical in nature and hence not be removed by standard cleaning methods, even though autoclaving would render them sterile. Though physical contact between the connector and the body or its fluids would be extremely unlikely, such chemicals, through normal handling, could be transferred to and contaminate other parts of the probe which may then be placed in bodily contact.

[0126] The ‘V’ shape of the sterilizable connector **608** serves to self-center the contact surfaces **610** and **612** (i.e., electrical contacts) to the contact surfaces **624** and **626** (i.e., mating contacts) during mating as well as to provide lateral as well as normal forces to the contact pads **614** and **616**. The latter is suitable to help with the necessary wire-to-contact-surface wiping action suitable for removing surface contaminants.

[0127] The sterilizable connector **600** should have a unitized molded assembly. The materials used to construct the sterilizable connector **600** should be selected such that a seamless, hermetic bond between the components can be formed. Further, a chemical bond between the components may also be formed. Such construction should avoid even the smallest of cracks or seams in which pathogens can survive. The material for the connector sections **604** and **608** should be selected such that they will survive repeated autoclaving cycles without losing their hermetic seal or mechanical integrity. The connector sections **604** and **608**, for example, may be made of polymer. All external material that may come into contact with human body should be FDA certified. Those skilled in the art would know how to select FDA certified materials that meet requirements for fabricating the autoclavable connector of the present invention.

[0128] **FIG. 16** is a graphic illustration of an exemplary environment in which embodiments of the present invention may be used. In **FIG. 16** an imaging subject is selected to be imaged. A sensor **1105** provides high frequency sound waves, which are coupled across an acoustic seal. The acoustic seal commonly comprises a sound conductive gel, which couples the sound waves between the sensor **1105** and the subject.

[0129] The sensor **1105** is coupled, via cable **1107**, to a connector **1109A**. Connector **1109A** is coupled to connector **1109B** and further coupled to an interface plug, which plugs into an imaging system **1115**. The imaging system displays the ultrasonic image on a display **1117**. The sensor **1105** is commonly manually **1119** manipulated by hand to obtain the most advantageous image.

[0130] In some embodiments of the invention the connector **1109A** may be mounted locally, that is on the body of the medical professional using the sensor. Such an attachment may provide a convenient way of detaching from cable **1111**, which might otherwise form an interfering tether when the sensor **1105** is not in use.

[0131] FIG. 17 is a graphic illustration of an acoustic sensor that may be held between two fingers. It is shaped like an hourglass or a chess piece, and is hereinafter referred to as the chess piece sensor. Two fingers 1205, as seen in FIG. 17, may sufficiently hold the chess piece sensor 1201. A common way to hold the chess piece 1201D is to hold it between the index and second finger as shown at 1209. An end on view of the chess piece sensor 1201A being held between two fingers 1205 is illustrated at 1207.

[0132] Although the chess piece sensor commonly may be held between the index and second finger as shown at 1209. It is not limited to such. Some practitioners may hold it between the thumb and index finger, or other fingers. There are advantages to holding the chess piece sensor in different positions and also advantages common to all the different methods of holding the sensor that are common to all methods, as will be explained below.

[0133] One advantage of the chess piece sensor that is common to various ways of holding the sensor is that the sensor may be rotated by a relative motion between the fingers holding the sensor. Another feature of the chess piece sensor is that although it may be rotated by relative motion between the holding fingers, its orientation is clearly visible by observing the orientation indicator 1203A through 1203C. The orientation indicator visually orients the chess piece sensor, because that actual imaging sensor 1211 is positioned at the opposite end of the chess piece from the orientation indicator, as illustrated at 1207 in FIG. 17. The chess piece sensor 1201A through 1201D also facilitates image plane adjustment regardless of hand position, as well as reducing non-ergonomic stress. In some sensors the orientation indicator, e.g. 1205B, may be rotated with respect to the sensor casing e.g. 1201B. The orientation of the sensor may therefore be changed with respect to a connector cable 1204.

[0134] The chess piece sensor can be held close to the finger tips for precise control or may be held near the palm of the hand, thereby allowing the palm and fingers to steady the sensor on the subject. In either case, because the sensor 1211 is on the same side of the hand as the medical professional's palm, a significant amount of pressure may be applied without having to grip a large bulky sensor with the hand.

[0135] The cable 1204 which couples the chess piece sensor to the imaging electronics may be a flat cable, such as, but not limited to, a printed circuit flex cable. Such a flat cable allows more freedom of movement than, for example, the commonly used coaxial cable.

[0136] FIG. 18A is a graphic illustration of an acoustic sensor that may be rotatably worn on a finger. The rotatable sensor comprises a ring 1305 intended to be worn on a finger as shown at 1301 in FIG. 18A. The ring has a track 1307 disposed concentrically with respect to the ring. The track 1307 provides a track on which the sensor 1303 may rotate. The track 1307 provides means for coupling the electrical connections 1309 to the sensor 1303.

[0137] Detents also may be built into the ring 1305 so a repeatable sensor position can be obtained. The sensor may rotate as generally shown at 1309. Because of the rotatability of the sensor with respect to the ring 1305 the sensor may swing out of the way when not in use, yet is handy for instant

use when needed. The rotatability of the sensor allows other activities to be done in a rapid cycle with imaging.

[0138] As with all finger-mounted embodiments they provide the advantage that the sensor may not be accidentally dropped. The finger may stay positively engaged with the sensor without any conscious effort by the wearer.

[0139] FIG. 18B is a graphic illustration of a local connection mechanism as may be used to provide a local disconnect for a finger worn sensor. In FIG. 18B a finger mounted sensor 1319 is coupled to a disconnect mechanism 1320 by a local cable 1318. The disconnect mechanism 1320 is mounted locally to the sensor 1319. By locally it is meant that the disconnect mechanism 1320 may be mounted on the arm, wrist, shoulder or other part of the body of the medical professional. Such a local mounting on the body of a medical professional may allow the medical professional to disconnect the sensor from the tether cable 1310 used to couple the sensor 1321 to the imaging system (1115 in FIG. 16, not shown in FIG. 18B). The ability to easily couple the imaging system to the sensor removes the necessity of remaining tethered to a cable coupled to the imaging system when the sensor is not in use in order to have quick access to the sensor.

[0140] An illustrative disconnect mechanism is shown in FIG. 18B. A first portion of the disconnect mechanism 1320A comprises a local cable 1318 that is used to couple the sensor 1319 to the first portion of the disconnect mechanism 1320A. The local cable is coupled to a plug housing 1317. The plug housing has a positive registration 1314 used to guide the first portion of the disconnect mechanism 1320A into a coupling with the second portion of the disconnect mechanism 1320B. The plug housing also includes interconnect pads 1316 to form an electrical connection with a contact array 1311 in order to make electrical contact with cable 1310, which is coupled to the interconnect pad in the second portion of the disconnect mechanism 1320B. To connect the first portion of the disconnect mechanism 1320A to the second portion of the disconnect mechanism 1320B the interconnect pads 1316 is inserted into a circuit engagement slot 1315, guided by the positive registration mechanism 1314 inserted into a negative portion of a registration mechanism 1313. Once both portions of the disconnect mechanism are engaged an actuation lever 1312 may be used to lock both portions of the disconnect mechanism in place. Through the use of the disconnect mechanism 1320 the sensor 1319 may be easily tethered and untethered from the imaging system. Accordingly an imaging sensor may be maintained handily maintained disposed on a finger and yet, when not in use the sensor may be conveniently untethered through the use of a locally (on the body of the medical professional) disconnect mechanism. Such an ability to maintain the sensor on a finger, where it may be easily and accurately manipulated, and to untether the sensor quickly and easily may provide readily available, yet unobtrusive, access to the sensor for imaging. The foregoing local disconnect may be used with any of the sensors configurations disclosed herein.

[0141] FIG. 19A is a graphic illustration of an acoustic sensor that may be extensibly worn on a finger. The sensor is disposed in a fingertip shaped finger extension 1407. The finger tip extension 1407 has a sensor 1409 disposed just beneath the surface. The sensor is linearly disposed in a

straight line from the undersurface of the finger 1411. A lateral member 1405 holds the fingertip extension 1407 in place. A circular gripping element 1403 secures the lateral member to the finger. The finger tip extension 1407 can retain the control provided by mounting the sensor to a finger while providing an extension for probing, for example in the case of rectal exams and the like.

[0142] FIG. 19B enclosures that may be used with finger mounted acoustic sensors in order to enhance the ability to use the sensor in a sterile environment. In many cases it may be advantageous to use one of the sensor embodiments in a sterile field. Some of the techniques of sterilization however may have adverse affects on a sensor. To provide for the use of a finger mounted sensor sterile encapsulating means as illustrated in FIG. 19B. In a first example of encapsulation a sensor sheath 1415A and a sensor 1413A are enclosed by a continuous sterilizable bag enclosure 1417. The cable 1421A that couples the sensor to the imaging system (not shown) may also be encapsulated in an isolating enclosure, such as the bag 1417. The isolating enclosure may extend to a disconnect mechanism such as that illustrated at 1320 in FIG. 18B, or may extend to cover only a portion of the cable, depending on how much of the sensor area needs to be sterilized and hence encapsulated.

[0143] Such an encapsulation may be built into a glove 1419 in such a case the sensor sheath 1415B may be disposed to be in contact with a finger up to the first finger joint 1423. Such an arrangement would allow bending of the finger joints within the glove and yet provide convenient placement of the sensor on the most distal finger bone. The sensor could then be coupled via a cable 1421B to a first portion of a disconnect device 1427 that may be molded into the glove. The glove could then be subjected to various sterilization procedures. The foregoing sterilization encapsulation may be used with any of the sensors configurations disclosed herein.

[0144] FIG. 20 is a graphic illustration of a flip up acoustic sensor designed to worn on a finger 1500. An acoustic sensor 1507 is mounted on a "U" shaped bracket 1503. The U bracket is swingably mounted using a hinge 1505 on a finger sleeve 1501. The U bracket 1503 and finger sleeve 1501 may have detents between the U bracket 1503 and finger sleeve 1501 such that the U bracket may be locked in several distinct positions. As examples of the detent positions a pad view is shown generally at 1509, a tip view is shown generally at 1511, and a clearance position is shown in 1513. Detents however can be arranged at any angle, depending on the use desired, and are not limited to the detent positions illustrated. If the flip up sensor is worn on the index finger the U bracket can be repositioned using the thumb or middle finger. The thumb may reposition the bracket no matter which finger the mechanism is worn on. This one hand operation can provide an advantage of not requiring the use of the opposite hand to reposition the sensor. Additionally the sensor can be used for imaging in a tip 1511 or a pad orientation 1509.

[0145] FIG. 21 is a graphic illustration of a tube and ring sensor mechanism designed to be worn on a finger and having a guidance attachment on an adjoining finger. The mechanism comprises a tube portion 1601, in which a finger is disposed, with a sensor 1605 mounted on the surface of the tube. The sensor 1605 may be mounted flush with the

surface of the tube 1601 or may protrude, thereby marking the actual location of the sensor. Mounted radially with the tube 1601 is a ring 1603 through which a second finger is disposed. The tube provides a convenient way of placing the sensor 1605 in contact with the subject. The ring provides a second finger for support and a convenient way to orient the sensor with respect to the surface of the first finger disposed within the tube portion of the mechanism. The tube 1601 is illustrated having the index finger of a hand disposed therein and having the middle finger disposed within the ring 1603. This arrangement is shown for illustrative purposes only. There is no intent to limit the arrangement to these two fingers.

[0146] FIG. 22 is a graphic illustration of a sleeve, having an acoustic sensor 1703 mounted to the surface of a sleeve 1701, designed to be worn over two fingers. The two-finger sleeve 1701 provides a convenient method of providing a pressure contact for the sensor as well as providing an easy method of positioning and orienting the sensor 1703. The sleeve may be worn on any combination of two fingers. For example, if the sleeve is worn on the two fingers adjacent to the index finger, as shown at 1705, the index finger is free to palpate the patient or steady the sensor.

[0147] FIG. 23 is a graphic illustration of an angled acoustic sensor array that may be worn on one finger. The sensors 1803, which form the angled acoustic sensor array 1801 on are mounted on a mounting surface worn about the finger 1805, and are arrayed at an essentially forty five degree angle. By arranging the sensors at a forty five degree angle and moving the hand plus and minus forty five degrees a full ninety degree sensor array rotation can be achieved without having to place the hand in an unnatural bend as illustrated at 1809. This array of sensors may be used with any of the embodiments described in the present application.

[0148] FIG. 24 is a graphic illustration of an extensible acoustic sensor designed to be worn on one finger. In FIG. 24 a finger sleeve 1901 provides the mounting for a slidable member 1903 (slider). The slider 1903 provides a way to extend the reach of an acoustic sensor beyond what would be obtainable by a simple finger mounted sensor. The sensor 1905 is mounted to the distal end of the slider and the proximal end of the slider is coupled to a slider sleeve 1907 by being passed through it and having an interference fit. The slider sleeve 1907 is coupled to the finger sleeve 1901 and the slider and finger sleeves may be fabricated from the same piece of material. The slider 1903 may have detents such that the detents cooperate with the slider sleeve to establish fixed amounts of slider extension.

[0149] FIG. 25 is a graphic illustration of an acoustic sensor, which includes an adjustable elastic band. The acoustic sensor 2001 is mounted upon a sensor mount 2005. The sensor mount is slotted such that an elastic band 2003 passes through a slot 2007 in the sensor mount in such a way that the elastic band may be adjusted. Because the elastic band may be adjusted the sensor may be mounted on the fingers as shown in 2009, on the palm of the hand as shown at 2011, or on a finger (not shown).

[0150] FIG. 26 is a graphic illustration of a snap on acoustic sensor, which may be attached to various points on a glove. The acoustic sensor is attached to the glove by a plurality of metallic snaps, which serve to attach the sensor to the glove and provide electrical connections. The plurality

of snaps are mounted on the glove on the palm side of the glove, and comprise a palm snap **2103A**, a thumb snap **2103B**, and four finger snaps **2103C**, **2103D**, **2103E**, and **2103F**. The palm snap **2103A** is mounted on the palm surface, the other snaps are mounted such that the snaps are positioned distal to the first finger joint on each of the fingers and thumb, in order to facilitate manipulation of the sensors. Each sensor is coupled to an electrical cable **2105** that conducts electrical signals to and from the sensors. The cabling to the sensors may be wired in a parallel arrangement, such that each sensor is an equivalent electrical point, or the cable may contain individual connections for each sensor. If the cabling contains individual cables then m Those skilled in the art will realize that multiple sensors may be used at the same time.

[0151] FIG. 27 is a graphic illustration of an acoustic sensor, which may be worn on a finger, having an integral needle guide. The sensor assembly comprises a sleeve **2201** for inserting a finger a finger. One end of the sleeve is closed and used for mounting a sensor **2205** to the tip of the finger. Essentially parallel to the sleeve a guide cylinder **2203**, having a smaller diameter than the sleeve, is mounted. The present embodiment may be used to image areas undergoing needle biopsy. The guide hole may be somewhat larger than the needle being used for biopsy so that a different portion of the area being imaged by the sensor **2205** may be biopsied.

[0152] FIG. 28 is a graphic illustration of a single finger mounted acoustic sensor. The mounting comprises a tube **2300** having two distinct sections. The sensor **2301** is coupled to a first section **2302**, which comprises generally a rigid tube first section. The rigid tube extends to just before the first joint of the finger **2315**. The second portion of the tube **2300** comprises a flexible second section **2305**. The flexible second section of the tube **2305** may form an interference fit with the finger. The second section **2305** may cover the first joint of the finger **2315** and may also cover the second finger joint **2317**. The second section **2305** may secure the tube **2300** to the finger making it more difficult to accidentally remove from the finger. However because the second section is flexible it does not interfere with the bending of the finger.

[0153] The sensor **2301**, in the rigid first section **2302** of the tube, may be coupled to a local disconnect **2309** by a local cable **2307** such as a ribbon or flex circuit cable, thereby further enhancing the ability to manipulate the sensor. The local disconnect may be coupled to the medical professional using the single finger mounted acoustic sensor, for example using a wrist strap **2311**. The local disconnect **2309** may comprise a first portion, for example a socket **2309A** and a second portion for example a plug **2309B**. By decoupling the socket **2309A** and plug **2309B** the medical professional using the single finger mounted acoustic sensor may disconnect the cable **2313** that couples the sensor **2301** to an imaging system (not shown). In such a manner the medical professional may disconnect from the tethering cable **2313** which is coupled to the imaging system, when the acoustic sensor is not in use. The tethering cable **2313** can be reconnected quickly and easily using the local disconnect **2309**, when the medical professional needs to use it for imaging.

[0154] It will be appreciated by those of ordinary skill in the art that the invention can be embodied in other specific

forms without departing from the spirit or essential character hereof. The present description is therefore considered in all respects to be illustrative and not restrictive. The scope of the invention is indicated by the appended claims, and all changes that come within the meaning and range of equivalents thereof are intended to be embraced therein.

[0155] For example, even though the present invention has been described herein in reference to medical ultrasound systems, it is broadly applicable to any medical or other systems that require use of portable sensor assemblies and/or sterilization of one or more connectors.

[0156] Further, those skilled in the art will realize that the term sensor, acoustic sensor or sensor array may include any type of sensor known in the art for example including linear array sensors, phased array sensors, piezoelectric sensors or any other type of sensors known in the art. Those skilled in the art will also realize that terms: sensor, acoustic, sensor and sensor array not only contemplate the sensor itself but may include the associated mounting and packaging.

What is claimed is:

1. An acoustic sensor apparatus comprising:

an hourglass shaped sensor casing having a top end and a bottom end;

an acoustic sensor mounted at the bottom end of the sensor casing; and

a orientation indicator coupled to the top end of the sensor casing such that the orientation indicator indicates the position of the sensor within the casing.

2. The apparatus of claim 1 wherein the orientation indicator and acoustic sensor are coupled together and the coupled combination is rotatable with respect to the sensor casing.

3. The apparatus of claim 1 further comprising a flat cable coupled to the acoustic sensor.

4. The apparatus of claim 1 further comprising a flex cable coupled to the acoustic sensor.

5. The apparatus of claim 1 further comprising a local disconnect coupled to the acoustic sensor.

6. The apparatus of claim 1 wherein the orientation indicator comprises:

a circular cover the top of the sensor casing; and

a slot disposed within the circular cover.

7. The apparatus of claim 1 wherein the orientation indicator comprises:

a circular cover the top of the sensor casing; and

a tab disposed within the circular cover.

8. An acoustic sensor apparatus comprising:

a ring sized to fit on a finger;

a tract disposed within the circumference of the ring; and

a sensor disposed in the track such that the sensor may be rotated with respect to the tract.

9. The apparatus of claim 8 further comprising a local disconnect coupled to the acoustic sensor.

10. The apparatus of claim 8 further comprising a plurality of detents disposed within the tract, thereby creating one or more identifiable positions for the sensor.

11. An acoustic sensor apparatus comprising:
 a fingertip shaped extension;
 a sensor disposed within the fingertip shaped extension;
 a circular gripping element that grips a finger; and
 a lateral member that couples the fingertip shaped extension to the circular gripping element.
12. The apparatus of claim 11 further comprising a local disconnect coupled to the acoustic sensor.
13. The apparatus of claim 11 further comprising a sterilizable bag enclosure that encapsulates the acoustic sensor.
14. The apparatus of claim 11 further comprising a sterilizable glove that encapsulates the acoustic sensor.
15. The apparatus of claim 14 wherein the sterilizable glove further includes a local disconnect as part of the glove.
16. An acoustic sensor apparatus comprising:
 a finger sleeve for gripping a finger;
 a hinge disposed at one end of the finger sleeve;
 a "U" bracket coupled to the hinge at the upper end; and
 a sensor coupled to the lower end of the "U" bracket.
17. The apparatus of claim 16 further comprising a local disconnect coupled to the acoustic sensor.
18. The apparatus of claim 16 further comprising a sterilizable bag enclosure that encapsulates the acoustic sensor.
19. The apparatus of claim 16 further comprising a sterilizable glove that encapsulates the acoustic sensor.
20. The apparatus of claim 19 wherein the sterilizable glove further includes a local disconnect as part of the glove.
21. The apparatus of claim 16 further comprising at least one detent that provides an identifiable location of the "U" bracket with respect to the finger sleeve.
22. An acoustic sensor apparatus comprising:
 a tube, having an open end for the insertion of a finger, and a closed end;
 a sensor disposed in the circumference of the tube proximate to the closed end;
 a ring, disposed such that the circumference of the ring is coupled to the circumference of the tube, such that a finger disposed in the ring is essentially parallel to a finger disposed within the tube.
23. The apparatus of claim 22 further comprising a local disconnect coupled to the acoustic sensor.
24. The apparatus of claim 22 further comprising a sterilizable bag enclosure that encapsulates the acoustic sensor.
25. The apparatus of claim 22 further comprising a sterilizable glove that encapsulates the acoustic sensor.
26. The apparatus of claim 25 wherein the sterilizable glove further includes a local disconnect as part of the glove.
27. An acoustic sensor apparatus comprising:
 an oval shaped pocket having an open end and a closed end, the pocket being of sufficient size to house two fingers disposed therein; and
 a sensor disposed on the surface of the pocket.
28. The apparatus of claim 27 further comprising a local disconnect coupled to the acoustic sensor.
29. The apparatus of claim 27 further comprising a sterilizable bag enclosure that encapsulates the acoustic sensor.
30. The apparatus of claim 27 further comprising a sterilizable glove that encapsulates the acoustic sensor.
31. The apparatus of claim 30 wherein the sterilizable glove further includes a local disconnect as part of the glove.
32. An acoustic sensor array apparatus comprising:
 a sensor mount having a flat side;
 a ring, for containing a finger, coupled to the sensor mount such that the flat side of the sensor mount may be made essentially parallel to a palm of a hand wearing the ring; and
 a plurality of sensors disposed on the flat side of the sensor mount such that a line connecting the sensors form a forty five degree angle with a finger disposed within the ring.
33. The apparatus of claim 32 further comprising a local disconnect coupled to the acoustic sensor.
34. The apparatus of claim 32 further comprising a sterilizable bag enclosure that encapsulates the acoustic sensor.
35. The apparatus of claim 32 further comprising a sterilizable glove that encapsulates the acoustic sensor.
36. The apparatus of claim 35 wherein the sterilizable glove further includes a local disconnect as part of the glove.
37. An acoustic sensor apparatus comprising:
 a finger sleeve for wearing on a finger;
 a slider sleeve coupled to and disposed in the same general orientation as the finger sleeve;
 a slider disposed such that the slidable member has an interference fit within the slider sleeve; and
 a sensor disposed at an end of the slider such that the sensor extends beyond the finger.
38. The apparatus of claim 37 further comprising a local disconnect coupled to the acoustic sensor.
39. The apparatus of claim 37 further comprising a sterilizable bag enclosure that encapsulates the acoustic sensor.
40. The apparatus of claim 37 further comprising a sterilizable glove that encapsulates the acoustic sensor.
41. The apparatus of claim 40 wherein the sterilizable glove further includes a local disconnect as part of the glove.
42. The apparatus of claim 37 further comprising a detent mechanism that provides at least one detent position of the slider.
43. An acoustic sensor apparatus comprising:
 a sensor mount having a sensor coupled to the mount;
 a slot disposed in the sensor mount; and
 a rubber band disposed in the sensor mount slot.
44. The apparatus of claim 43 further comprising a local disconnect coupled to the acoustic sensor.
45. The apparatus of claim 43 further comprising a sterilizable bag enclosure that encapsulates the acoustic sensor.
46. The apparatus of claim 43 further comprising a sterilizable glove that encapsulates the acoustic sensor.
47. The apparatus of claim 46 wherein the sterilizable glove further includes a local disconnect as part of the glove.

- 48.** An acoustic sensor apparatus comprising:
a glove having a plurality of snap attachments, a cable electrically coupled to the snap attachments; and
a sensor that attaches to at least one of the plurality of snap attachments and makes an electrical connection to the cable.
- 49.** The apparatus of claim 48 further comprising a local disconnect coupled to the acoustic sensor.
- 50.** The apparatus of claim 48 wherein the electrical coupling of the plurality of attachments are arranged in parallel.
- 51.** The apparatus of claim 50 wherein the electrical coupling of the plurality of attachments comprise individual non-parallel connections with the cable.
- 52.** An acoustic sensor apparatus comprising:
a tube having a closed end and an open end for receiving a finger;
a guide tube having both ends open and attached in parallel to the tube having one closed end; and
a sensor disposed on the closed end of the tube.
- 53.** The apparatus of claim 52 further comprising a local disconnect coupled to the acoustic sensor.
- 54.** The apparatus of claim 52 further comprising a sterilizable bag enclosure that encapsulates the acoustic sensor and the guide tube.
- 55.** The apparatus of claim 52 further comprising a sterilizable glove that encapsulates the acoustic sensor and the guide tube.
- 56.** The apparatus of claim 55 wherein the sterilizable glove further includes a local disconnect as part of the glove.

* * * * *

专利名称(译)	用于超声成像的声学医疗传感器		
公开(公告)号	US20050096554A1	公开(公告)日	2005-05-05
申请号	US10/863644	申请日	2004-06-08
[标]申请(专利权)人(译)	DUDIK EVAN中号 SCHUTZ RON BECK威廉的一句话JR REINISCH DANA DAANE一个LAURENCE CORBETT SCOTT S III HOYT JOSHUA PARK ERIC COOKE DOUG		
申请(专利权)人(译)	DUDIK EVAN M. SCHUTZ RON BECK WILLIAM A.JR. REINISCH DANA DAANE LAURENCE A. CORBETT SCOTT S.III HOYT JOSHUA K. PARK ERIC COOKE DOUG		
[标]发明人	DUDIK EVAN M SCHUTZ RON BECK WILLIAM A JR REINISCH DANA DAANE LAURENCE A CORBETT SCOTT S III HOYT JOSHUA K PARK ERIC COOKE DOUG		
发明人	DUDIK, EVAN M. SCHUTZ, RON BECK, WILLIAM A. JR. REINISCH, DANA DAANE, LAURENCE A. CORBETT, SCOTT S. III HOYT, JOSHUA K. PARK, ERIC COOKE, DOUG		
IPC分类号	A61B5/02 A61B8/00 H01R13/24 H01R13/52 H01R13/533		
CPC分类号	A61B5/6806 A61B5/6826 A61B5/6838 A61B8/00 H01R2201/12 A61B2562/187 H01R13/2414 H01R13/5224 H01R13/533 A61B8/4209 A61B8/4227 A61B8/4422 A61B8/4455		
优先权	60/429614 2002-11-27 US		
外部链接	Espacenet USPTO		
摘要(译)			

手指安装的声学传感器。手指安装的声学传感器的各传感器可以相对于壳体旋转。其他实施例包括用于佩戴在手指上的安装管。传感器嵌入管中和环上，使得技术人员的手指可以轻松定位。其他实施例包括用于在传感器上安装传感器并用于稳定传感器的环。手和手指安装的传感器可以用于向传感器提供必要的压力，并且还提供可以使用手和手指运动来操纵的传感器。在其他实施例中，公开了具有局部断开的传感器。这种断开连接可以连接到医疗专业人员的衣服上，通过手腕或臂带或类似物连接。各种传感器封装可以伴随使用扁平或柔性电缆，以最小化操纵传感器所需的扭矩。这种传感器可以与超声平台一起使用，以产生，处理和显示超声图像。

