



US009192355B2

(12) **United States Patent**  
**Smith et al.**

(10) **Patent No.:** **US 9,192,355 B2**  
(45) **Date of Patent:** **Nov. 24, 2015**

(54) **MULTIPLE APERTURE ULTRASOUND  
ARRAY ALIGNMENT FIXTURE**

(58) **Field of Classification Search**

USPC ..... 702/100  
See application file for complete search history.

(71) Applicant: **Maui Imaging, Inc.**, Sunnyvale, CA  
(US)

(56) **References Cited**

(72) Inventors: **David M. Smith**, Lodi, CA (US);  
**Sharon L. Adam**, San Jose, CA (US);  
**Donald F. Specht**, Los Altos, CA (US);  
**Kenneth D. Brewer**, Santa Clara, CA  
(US); **John P. Lunsford**, San Carlos, CA  
(US)

U.S. PATENT DOCUMENTS

3,174,286 A 3/1965 Erickson  
3,895,381 A 7/1975 Kock  
(Continued)

(73) Assignee: **MAUI IMAGING, INC.**, Sunnyvale,  
CA (US)

CN 102123668 7/2011  
EP 1949856 A1 7/2008  
(Continued)

(\*) Notice: Subject to any disclaimer, the term of this  
patent is extended or adjusted under 35  
U.S.C. 154(b) by 242 days.

FOREIGN PATENT DOCUMENTS

(21) Appl. No.: **13/894,192**

OTHER PUBLICATIONS  
Belevich et al.; U.S. Appl. No. 13/964,701 entitled "Calibration of  
Multiple Aperture Ultrasound Probes," filed Aug. 12, 2013.

(22) Filed: **May 14, 2013**

(Continued)

(65) **Prior Publication Data**

US 2013/0247350 A1 Sep. 26, 2013

*Primary Examiner* — Tung S Lau

(74) *Attorney, Agent, or Firm* — Shay Glenn LLP

**Related U.S. Application Data**

(63) Continuation of application No. 12/760,327, filed on  
Apr. 14, 2010, now Pat. No. 8,473,239.

(60) Provisional application No. 61/169,200, filed on Apr.  
14, 2009.

(57) **ABSTRACT**

Increasing the effective aperture of an ultrasound imaging  
probe by including more than one probe head and using the  
elements of all of the probes to render an image can greatly  
improve the lateral resolution of the generated image. In order  
to render an image, the relative positions of all of the elements  
must be known precisely. A calibration fixture is described in  
which the probe assembly to be calibrated is placed above a  
test block and transmits ultrasonic pulses through the test  
block to an ultrasonic sensor. As the ultrasonic pulses are  
transmitted through some or all of the elements in the probe to  
be tested, the differential transit times of arrival of the wave-  
form are measured precisely. From these measurements the  
relative positions of the probe elements can be computed and  
the probe can be aligned.

(51) **Int. Cl.**

**A61B 8/00** (2006.01)

**G01S 7/52** (2006.01)

(Continued)

(52) **U.S. Cl.**

CPC ... **A61B 8/42** (2013.01); **A61B 8/00** (2013.01);

**A61B 8/4218** (2013.01); **A61B 8/587**

(2013.01);

(Continued)

**14 Claims, 31 Drawing Sheets**

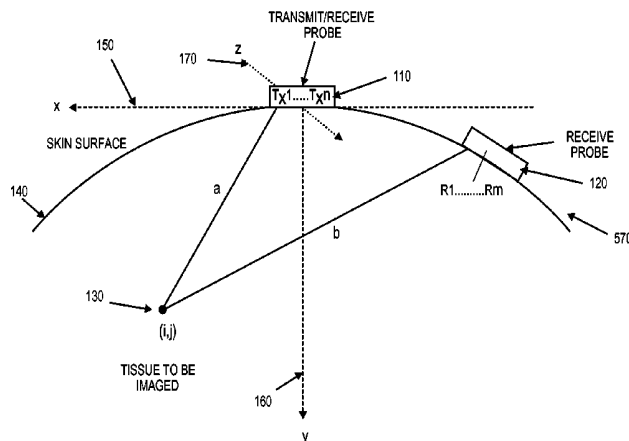

- (51) **Int. Cl.**  
**G01S 15/89** (2006.01)  
**A61B 8/08** (2006.01)
- (52) **U.S. Cl.**  
CPC ..... **G01S 7/5205** (2013.01); **G01S 15/8913**  
(2013.01); **A61B 8/0883** (2013.01); **Y10T**  
29/49778 (2015.01)

(56) **References Cited**

## U.S. PATENT DOCUMENTS

4,055,988 A *	11/1977	Dutton, Jr. ....	73/620	5,820,561 A	10/1998	Olstad et al.
4,072,922 A	2/1978	Taner et al.		5,838,564 A	11/1998	Bahorich et al.
4,097,835 A	6/1978	Green		5,850,622 A	12/1998	Vassiliou et al.
4,105,018 A	8/1978	Greenleaf et al.		5,862,100 A	1/1999	VerWest
4,259,733 A	3/1981	Taner et al.		5,870,691 A	2/1999	Partyka et al.
4,271,842 A	6/1981	Specht et al.		5,876,342 A	3/1999	Chen et al.
4,325,257 A	4/1982	Kino et al.		5,891,038 A	4/1999	Seyed-Bolorforosh et al.
4,333,474 A	6/1982	Nigam		5,892,732 A	4/1999	Gersztenkorn
4,339,952 A	7/1982	Foster		5,916,169 A	6/1999	Hanafy et al.
4,452,084 A	6/1984	Taenzler		5,919,139 A	7/1999	Lin
4,501,279 A	2/1985	Seo		5,920,285 A	7/1999	Benjamin
4,539,847 A	9/1985	Paap		5,930,730 A	7/1999	Marfurt et al.
4,566,459 A	1/1986	Umemura et al.		5,940,778 A	8/1999	Marfurt et al.
4,567,768 A	2/1986	Satoh et al.		5,964,707 A	10/1999	Fenster et al.
4,662,222 A	5/1987	Johnson		5,969,661 A	10/1999	Benjamin
4,669,482 A	6/1987	Ophir		5,999,836 A	12/1999	Nelson et al.
4,682,497 A	7/1987	Sasaki		6,007,499 A	12/1999	Martin et al.
4,781,199 A	11/1988	Hirama et al.		6,013,032 A	1/2000	Savord
4,817,434 A	4/1989	Anderson		6,014,473 A	1/2000	Hossack et al.
4,831,601 A	5/1989	Breimesser et al.		6,048,315 A	4/2000	Chiao et al.
4,893,284 A	1/1990	Magrane		6,049,509 A	4/2000	Sonneland et al.
4,893,628 A	1/1990	Angelsen		6,050,943 A	4/2000	Slayton et al.
5,050,588 A	9/1991	Grey et al.		6,056,693 A	5/2000	Haider
5,141,738 A	8/1992	Razor et al.		6,058,074 A	5/2000	Swan et al.
5,161,536 A	11/1992	Vilkomerson et al.		6,077,224 A	6/2000	Lang et al.
5,197,475 A	3/1993	Antich et al.		6,092,026 A	7/2000	Bahorich et al.
5,226,019 A	7/1993	Bahorich		6,122,538 A	9/2000	Sliwa, Jr. et al.
5,230,339 A	7/1993	Charlebois		6,123,670 A	9/2000	Mo
5,269,309 A	12/1993	Fort et al.		6,129,672 A	10/2000	Seward et al.
5,278,757 A	1/1994	Hocter et al.		6,135,960 A	10/2000	Holmberg
5,293,871 A	3/1994	Reinstein et al.		6,138,075 A	10/2000	Yost
5,299,576 A	4/1994	Shiba		6,148,095 A	11/2000	Prause et al.
5,301,674 A	4/1994	Erikson et al.		6,162,175 A	12/2000	Marian, Jr. et al.
5,305,756 A	4/1994	Entrekin et al.		6,166,384 A	12/2000	Dentinger et al.
5,339,282 A	8/1994	Kuhn et al.		6,166,853 A	12/2000	Sapia et al.
5,340,510 A	8/1994	Bowen		6,193,665 B1	2/2001	Hall et al.
5,345,426 A	9/1994	Lipschutz		6,196,739 B1	3/2001	Silverbrook
5,355,888 A	10/1994	Kendall		6,200,266 B1	3/2001	Shokrollahi et al.
5,398,216 A	3/1995	Hall et al.		6,210,335 B1	4/2001	Miller
5,409,010 A	4/1995	Beach et al.		6,213,958 B1	4/2001	Winder
5,442,462 A	8/1995	Guissin		6,221,019 B1	4/2001	Kantorovich
5,503,152 A	4/1996	Oakley et al.		6,231,511 B1	5/2001	Bae
5,515,853 A	5/1996	Smith et al.		6,238,342 B1	5/2001	Feleppa et al.
5,515,856 A	5/1996	Olstad et al.		6,246,901 B1	6/2001	Benaron
5,522,393 A	6/1996	Phillips et al.		6,251,073 B1	6/2001	Imran et al.
5,526,815 A	6/1996	Granz et al.		6,264,609 B1	7/2001	Herrington et al.
5,544,659 A	8/1996	Banjanin		6,266,551 B1	7/2001	Osadchy et al.
5,558,092 A	9/1996	Unger et al.		6,278,949 B1	8/2001	Alam
5,564,423 A	10/1996	Mele et al.		6,289,230 B1	9/2001	Chaiken et al.
5,568,812 A	10/1996	Murashita et al.		6,304,684 B1	10/2001	Niczyporuk et al.
5,570,691 A	11/1996	Wright et al.		6,309,356 B1	10/2001	Ustuner et al.
5,581,517 A	12/1996	Gee et al.		6,324,453 B1	11/2001	Breed et al.
5,625,149 A	4/1997	Gururaja et al.		6,345,539 B1	2/2002	Rawes et al.
5,628,320 A	5/1997	Teo		6,361,500 B1	3/2002	Masters
5,673,697 A	10/1997	Bryan et al.		6,363,033 B1	3/2002	Cole et al.
5,675,550 A	10/1997	Ekhaus		6,374,185 B1	4/2002	Taner et al.
5,720,291 A	2/1998	Schwartz		6,394,955 B1	5/2002	Perlitz
5,720,708 A	2/1998	Lu et al.		6,423,002 B1	7/2002	Hossack
5,744,898 A	4/1998	Smith et al.		6,436,046 B1	8/2002	Napolitano et al.
5,769,079 A	6/1998	Hossack		6,449,821 B1	9/2002	Sudol et al.
5,784,334 A	7/1998	Sena et al.		6,450,965 B2	9/2002	Williams et al.
5,785,654 A	7/1998	Iinuma et al.		6,468,216 B1	10/2002	Powers et al.
5,795,297 A	8/1998	Daigle		6,471,650 B2	10/2002	Powers et al.
5,797,845 A	8/1998	Barabash et al.		6,475,150 B2	11/2002	Haddad
5,798,459 A	8/1998	Ohba et al.		6,480,790 B1	11/2002	Calvert et al.
				6,487,502 B1	11/2002	Taner
				6,499,536 B1	12/2002	Ellingsen
				6,508,768 B1	1/2003	Hall et al.
				6,517,484 B1	2/2003	Wilk et al.
				6,526,163 B1	2/2003	Halmann et al.
				6,543,272 B1	4/2003	Vitek
				6,547,732 B2	4/2003	Jago
				6,551,246 B1	4/2003	Ustuner et al.
				6,565,510 B1	5/2003	Haider
				6,585,647 B1	7/2003	Winder
				6,604,421 B1	8/2003	Li
				6,614,560 B1	9/2003	Silverbrook
				6,620,101 B2	9/2003	Azzam et al.
				6,652,461 B1	11/2003	Levkovitz

(56)

## References Cited

## U.S. PATENT DOCUMENTS

6,668,654	B2	12/2003	Dubois et al.	7,984,637	B2	7/2011	Ao et al.
6,672,165	B2	1/2004	Rather et al.	7,984,651	B2	7/2011	Randall et al.
6,681,185	B1	1/2004	Young et al.	8,002,705	B1	8/2011	Napolitano et al.
6,690,816	B2	2/2004	Aylward et al.	8,007,439	B2	8/2011	Specht
6,692,450	B1	2/2004	Coleman	8,057,392	B2	11/2011	Hossack et al.
6,695,778	B2	2/2004	Golland et al.	8,057,393	B2	11/2011	Yao et al.
6,702,745	B1	3/2004	Smythe	8,079,263	B2	12/2011	Randall et al.
6,719,693	B2	4/2004	Richard	8,079,956	B2	12/2011	Azuma et al.
6,728,567	B2	4/2004	Rather et al.	8,088,067	B2	1/2012	Vortman et al.
6,752,762	B1	6/2004	DeJong et al.	8,088,068	B2	1/2012	Yao et al.
6,755,787	B2	6/2004	Hossack et al.	8,088,071	B2	1/2012	Hwang et al.
6,780,152	B2	8/2004	Ustuner et al.	8,105,239	B2	1/2012	Specht
6,790,182	B2	9/2004	Eck et al.	8,135,190	B2	3/2012	Bae et al.
6,837,853	B2	1/2005	Marian	8,157,737	B2	4/2012	Zhang et al.
6,843,770	B2	1/2005	Sumanaweera	8,182,427	B2	5/2012	Wu et al.
6,847,737	B1	1/2005	Kouri et al.	8,202,219	B2	6/2012	Luo et al.
6,854,332	B2	2/2005	Alleyne	8,277,383	B2	10/2012	Specht
6,932,767	B2	8/2005	Landry et al.	8,412,307	B2	4/2013	Willis et al.
7,033,320	B2	4/2006	Von Behren et al.	8,419,642	B2	4/2013	Sandrin et al.
7,087,023	B2	8/2006	Daft et al.	8,473,239	B2	6/2013	Specht et al.
7,104,956	B1	9/2006	Christopher	8,478,382	B2	7/2013	Burnside et al.
7,217,243	B2	5/2007	Takeuchi	8,532,951	B2	9/2013	Roy et al.
7,221,867	B2	5/2007	Silverbrook	8,634,615	B2	1/2014	Brabec
7,231,072	B2	6/2007	Yamano et al.	8,672,846	B2	3/2014	Napolitano et al.
7,269,299	B2	9/2007	Schroeder	2002/0035864	A1	3/2002	Paltieli et al.
7,283,652	B2	10/2007	Mendonca et al.	2002/0087071	A1	7/2002	Schmitz et al.
7,285,094	B2	10/2007	Nohara et al.	2002/0111568	A1	8/2002	Bukshpan
7,313,053	B2	12/2007	Wodnicki	2002/0161299	A1	10/2002	Prater et al.
7,366,704	B2	4/2008	Reading et al.	2003/0028111	A1	2/2003	Vaezy et al.
7,402,136	B2	7/2008	Hossack et al.	2003/0040669	A1	2/2003	Grass et al.
7,410,469	B1	8/2008	Talish et al.	2003/0228053	A1	12/2003	Li et al.
7,415,880	B2	8/2008	Renzel	2004/0054283	A1	3/2004	Corey et al.
7,443,765	B2	10/2008	Thomenius et al.	2004/0068184	A1	4/2004	Trahey et al.
7,444,875	B1	11/2008	Wu et al.	2004/0100163	A1	5/2004	Baumgartner et al.
7,447,535	B2	11/2008	Lavi	2004/0111028	A1	6/2004	Abe et al.
7,448,998	B2	11/2008	Robinson	2004/0122313	A1	6/2004	Moore et al.
7,466,848	B2	12/2008	Metaxas et al.	2004/0122322	A1	6/2004	Moore et al.
7,469,096	B2	12/2008	Silverbrook	2004/0127793	A1	7/2004	Mendlein et al.
7,474,778	B2	1/2009	Shinomura et al.	2004/0138565	A1	7/2004	Trucco
7,481,577	B2	1/2009	Ramamurthy et al.	2004/0144176	A1	7/2004	Yoden
7,491,171	B2	2/2009	Barthe et al.	2004/0236217	A1	11/2004	Cerwin et al.
7,497,828	B1	3/2009	Wilk et al.	2004/0236223	A1	11/2004	Barnes et al.
7,497,830	B2	3/2009	Li	2005/0004449	A1	1/2005	Mitschke et al.
7,510,529	B2	3/2009	Chou et al.	2005/0053305	A1	3/2005	Li et al.
7,514,851	B2	4/2009	Wilser et al.	2005/0054910	A1	3/2005	Tremblay et al.
7,549,962	B2	6/2009	Dreschel et al.	2005/0090743	A1	4/2005	Kawashima et al.
7,574,026	B2	8/2009	Rasche et al.	2005/0090745	A1	4/2005	Steen
7,625,343	B2	12/2009	Cao et al.	2005/0111846	A1	5/2005	Steinbacher et al.
7,637,869	B2	12/2009	Sudol	2005/0113694	A1	5/2005	Haugen et al.
7,668,583	B2	2/2010	Fegert et al.	2005/0124883	A1	6/2005	Hunt
7,674,228	B2	3/2010	Williams et al.	2005/0131300	A1	6/2005	Bakircioglu et al.
7,682,311	B2	3/2010	Simopoulos et al.	2005/0147297	A1	7/2005	McLaughlin et al.
7,699,776	B2	4/2010	Walker et al.	2005/0165312	A1	7/2005	Knowles et al.
7,722,541	B2	5/2010	Cai	2005/0203404	A1	9/2005	Freiburger
7,744,532	B2	6/2010	Ustuner et al.	2005/0215883	A1	9/2005	Hundley et al.
7,750,311	B2	7/2010	Daghighian	2005/0240125	A1	10/2005	Makin et al.
7,785,260	B2	8/2010	Umemura et al.	2005/0252295	A1	11/2005	Fink et al.
7,787,680	B2	8/2010	Ahn et al.	2005/0281447	A1	12/2005	Moreau-Gobard et al.
7,806,828	B2	10/2010	Stringer	2005/0288588	A1	12/2005	Weber et al.
7,819,810	B2	10/2010	Stringer et al.	2006/0062447	A1	3/2006	Rinck et al.
7,822,250	B2	10/2010	Yao et al.	2006/0074313	A1	4/2006	Slayton et al.
7,824,337	B2	11/2010	Abe et al.	2006/0074315	A1	4/2006	Liang et al.
7,833,163	B2	11/2010	Cai	2006/0074320	A1	4/2006	Yoo et al.
7,837,624	B1	11/2010	Hossack et al.	2006/0079759	A1	4/2006	Vaillant et al.
7,846,097	B2	12/2010	Jones et al.	2006/0079778	A1	4/2006	Mo et al.
7,850,613	B2	12/2010	Stribling	2006/0079782	A1	4/2006	Beach et al.
7,862,508	B2	1/2011	Davies et al.	2006/0094962	A1	5/2006	Clark
7,876,945	B2	1/2011	Lötjönen	2006/0111634	A1	5/2006	Wu
7,887,486	B2	2/2011	Ustuner et al.	2006/0122506	A1	6/2006	Davies et al.
7,901,358	B2	3/2011	Mehi et al.	2006/0173327	A1	8/2006	Kim
7,914,451	B2	3/2011	Davies	2006/0262291	A1	11/2006	Hess et al.
7,919,906	B2	4/2011	Cerofolini	2006/0262961	A1	11/2006	Holsing et al.
7,926,350	B2	4/2011	Kröning et al.	2007/0016022	A1	1/2007	Blalock et al.
7,927,280	B2	4/2011	Davidsen	2007/0016044	A1	1/2007	Blalock et al.
7,972,271	B2	7/2011	Johnson et al.	2007/0036414	A1	2/2007	Georgescu et al.
				2007/0055155	A1	3/2007	Owen et al.
				2007/0078345	A1	4/2007	Mo et al.
				2007/0088213	A1	4/2007	Poland
				2007/0138157	A1	6/2007	Dane et al.

(56)

## References Cited

## U.S. PATENT DOCUMENTS

2007/0161898 A1 7/2007 Hao et al.  
 2007/0161904 A1 7/2007 Urbano  
 2007/0167752 A1 7/2007 Proulx et al.  
 2007/0167824 A1 7/2007 Lee et al.  
 2007/0232914 A1 10/2007 Chen et al.  
 2007/0238985 A1 10/2007 Smith et al.  
 2007/0242567 A1 10/2007 Daft et al.  
 2008/0110261 A1 5/2008 Randall et al.  
 2008/0110263 A1 5/2008 Klessel et al.  
 2008/0112265 A1 5/2008 Urbano et al.  
 2008/0114241 A1 5/2008 Randall et al.  
 2008/0114245 A1 5/2008 Randall et al.  
 2008/0114246 A1 5/2008 Randall et al.  
 2008/0114247 A1 5/2008 Urbano et al.  
 2008/0114248 A1 5/2008 Urbano et al.  
 2008/0114249 A1 5/2008 Randall et al.  
 2008/0114250 A1 5/2008 Urbano et al.  
 2008/0114251 A1 5/2008 Weymer et al.  
 2008/0114252 A1 5/2008 Randall et al.  
 2008/0114253 A1 5/2008 Randall et al.  
 2008/0114255 A1 5/2008 Schwartz et al.  
 2008/0125659 A1 5/2008 Wilser et al.  
 2008/0181479 A1 7/2008 Yang et al.  
 2008/0183075 A1 7/2008 Govari et al.  
 2008/0188747 A1 8/2008 Randall et al.  
 2008/0188750 A1 8/2008 Randall et al.  
 2008/0194957 A1 8/2008 Hocter et al.  
 2008/0194958 A1 8/2008 Lee et al.  
 2008/0194959 A1 8/2008 Wang et al.  
 2008/0208061 A1 8/2008 Halmann  
 2008/0242996 A1 10/2008 Hall et al.  
 2008/0249408 A1 10/2008 Palmeri et al.  
 2008/0255452 A1 10/2008 Entrekin  
 2008/0269604 A1 10/2008 Boctor et al.  
 2008/0269613 A1 10/2008 Summers et al.  
 2008/0275344 A1 11/2008 Glide-Hurst et al.  
 2008/0285819 A1 11/2008 Konofagou et al.  
 2008/0287787 A1 11/2008 Sauer et al.  
 2008/0294045 A1 11/2008 Ellington et al.  
 2008/0294050 A1 11/2008 Shinomura et al.  
 2008/0294052 A1 11/2008 Wilser et al.  
 2008/0306382 A1 12/2008 Guracar et al.  
 2008/0306386 A1 12/2008 Baba et al.  
 2008/0319317 A1 12/2008 Kamiyama et al.  
 2009/0010459 A1 1/2009 Garbini et al.  
 2009/0012393 A1 1/2009 Choi  
 2009/0016163 A1 1/2009 Freeman et al.  
 2009/0018445 A1 1/2009 Schers et al.  
 2009/0024039 A1 1/2009 Wang et al.  
 2009/0036780 A1 2/2009 Abraham  
 2009/0043206 A1 2/2009 Towfiq et al.  
 2009/0048519 A1 2/2009 Hossack et al.  
 2009/0069681 A1 3/2009 Lundberg et al.  
 2009/0069686 A1 3/2009 Daft et al.  
 2009/0069692 A1 3/2009 Cooley et al.  
 2009/0099483 A1 4/2009 Rybyanets  
 2009/0112095 A1 4/2009 Daigle  
 2009/0131797 A1 5/2009 Jeong et al.  
 2009/0143680 A1 6/2009 Yao et al.  
 2009/0148012 A1 6/2009 Altmann et al.  
 2009/0150094 A1 6/2009 Van Velsor et al.  
 2009/0182237 A1 7/2009 Angelsen et al.  
 2009/0198134 A1 8/2009 Hashimoto et al.  
 2009/0203997 A1 8/2009 Ustuner  
 2009/0208080 A1 8/2009 Grau et al.  
 2009/0259128 A1 10/2009 Stribling  
 2009/0264760 A1 10/2009 Lazebnik et al.  
 2009/0306510 A1 12/2009 Hashiba et al.  
 2009/0326379 A1 12/2009 Daigle et al.  
 2010/0010354 A1 1/2010 Skerl et al.  
 2010/0016725 A1 1/2010 Thiele  
 2010/0063397 A1 3/2010 Wagner  
 2010/0063399 A1 3/2010 Walker et al.  
 2010/0069751 A1 3/2010 Hazard et al.  
 2010/0069756 A1 3/2010 Ogasawara et al.

2010/0106431 A1 4/2010 Baba et al.  
 2010/0109481 A1 5/2010 Buccafusca  
 2010/0121193 A1 5/2010 Fukukita et al.  
 2010/0121196 A1 5/2010 Hwang et al.  
 2010/0130855 A1 5/2010 Lundberg et al.  
 2010/0168566 A1 7/2010 Bercoff et al.  
 2010/0168578 A1 7/2010 Garson, Jr. et al.  
 2010/0174194 A1 7/2010 Chiang et al.  
 2010/0217124 A1 8/2010 Cooley  
 2010/0240994 A1 9/2010 Zheng  
 2010/0249570 A1 9/2010 Carson et al.  
 2010/0249596 A1 9/2010 Magee  
 2010/0256488 A1 10/2010 Kim et al.  
 2010/0262013 A1 10/2010 Smith et al.  
 2010/0266176 A1 10/2010 Masumoto et al.  
 2010/0286525 A1 11/2010 Osumi  
 2010/0286527 A1 11/2010 Cannon et al.  
 2010/0310143 A1 12/2010 Rao et al.  
 2010/0324418 A1 12/2010 El-Aklouk et al.  
 2010/0324423 A1 12/2010 El-Aklouk et al.  
 2010/0329521 A1 12/2010 Beymer et al.  
 2011/0005322 A1 1/2011 Ustuner  
 2011/0016977 A1 1/2011 Guracar  
 2011/0021920 A1 1/2011 Shafir et al.  
 2011/0021923 A1 1/2011 Daft et al.  
 2011/0033098 A1 2/2011 Richter et al.  
 2011/0044133 A1 2/2011 Tokita  
 2011/0066030 A1 3/2011 Yao  
 2011/0098565 A1 4/2011 Masuzawa  
 2011/0112400 A1 5/2011 Emery et al.  
 2011/0112404 A1 5/2011 Gourevitch  
 2011/0125017 A1 5/2011 Ramamurthy et al.  
 2011/0178400 A1 7/2011 Specht et al.  
 2011/0201933 A1 8/2011 Specht et al.  
 2011/0270088 A1 11/2011 Shiina  
 2012/0036934 A1 2/2012 Kröning et al.  
 2012/0057428 A1 3/2012 Specht et al.  
 2012/0095343 A1 4/2012 Smith et al.  
 2012/0095347 A1 4/2012 Adam et al.  
 2012/0116226 A1 5/2012 Specht  
 2012/0137778 A1 6/2012 Kitazawa et al.  
 2012/0165670 A1 6/2012 Shi et al.  
 2012/0179044 A1 7/2012 Chiang et al.  
 2012/0243763 A1 9/2012 Wen et al.  
 2013/0035595 A1 2/2013 Specht  
 2013/0131516 A1 5/2013 Katsuyama  
 2013/0144166 A1 6/2013 Specht et al.  
 2013/0172743 A1 7/2013 Brewer et al.  
 2013/0261463 A1 10/2013 Chiang et al.

## FOREIGN PATENT DOCUMENTS

EP 2058796 A2 5/2009  
 EP 2101191 A2 9/2009  
 EP 2182352 A2 5/2010  
 EP 2187813 A1 5/2010  
 EP 2198785 A1 6/2010  
 EP 1757955 B1 11/2010  
 EP 2325672 A1 5/2011  
 EP 2356941 A1 8/2011  
 EP 1979739 10/2011  
 EP 2294400 2/2012  
 EP 1840594 B1 6/2012  
 EP 1850743 B1 12/2012  
 EP 1594404 B1 9/2013  
 EP 2026280 B1 10/2013  
 FR 2851662 A1 8/2004  
 JP S49-11189 A 1/1974  
 JP S54-44375 A 4/1979  
 JP S55-103839 A 8/1980  
 JP 59-101143 6/1984  
 JP S59-174151 A 10/1984  
 JP S60-13109 U 1/1985  
 JP S60-68836 A 4/1985  
 JP 501431 5/1990  
 JP 4-67856 3/1992  
 JP 05-042138 A 2/1993  
 JP 6-125908 5/1994  
 JP 7-051266 A 2/1995

(56)

## References Cited

## FOREIGN PATENT DOCUMENTS

JP	08-252253	10/1996
JP	9-103429 A	4/1997
JP	9-201361 A	8/1997
JP	10-216128 A	8/1998
JP	11-089833 A	4/1999
JP	2001-245884 A	9/2001
JP	2002-209894 A	7/2002
JP	2002-253548	9/2002
JP	2002-253549 A	9/2002
JP	2004-167092 A	6/2004
JP	2004-215987	8/2004
JP	2004-337457	12/2004
JP	2004-351214	12/2004
JP	2005-523792	8/2005
JP	2005-526539	9/2005
JP	2006-122657 A	5/2006
JP	2008-122209	5/2008
JP	2008-513763 A	5/2008
JP	2008-259541 A	10/2008
JP	20105375	1/2010
KR	1020090103408 A	10/2009
WO	WO 92/18054 A1	10/1992
WO	WO 98/00719 A2	1/1998
WO	WO02/084594 A2	10/2002
WO	WO2005/009245 A1	2/2005
WO	WO 2006/114735 A1	11/2006
WO	WO 2007/127147 A2	11/2007
WO	WO2009/060182 A2	5/2009
WO	WO 2010/017445 A2	2/2010
WO	WO 2010/095094 A1	8/2010
WO	WO2011/057252 A1	5/2011
WO	WO2011/064688 A1	6/2011
WO	WO2011/100697 A1	8/2011
WO	WO2011/123529 A1	10/2011

## OTHER PUBLICATIONS

Call et al.; U.S. Appl. No. 13/971,689 entitled "Ultrasound Imaging System Memory Architecture," filed Aug. 20, 2013.

Hendee et al.; *Medical Imaging Physics*; Wiley-Liss, Inc. 4th Edition; Chap. 19-22; pp. 303-353; © 2002 (year of pub. sufficiently earlier than effective US filed and any foreign priority date).

Wikipedia; Point cloud; 2 pages; Nov. 24, 2014; retrieved from the internet ([https://en.wikipedia.org/w/index.php?title=Point\\_cloud&oldid=472583138](https://en.wikipedia.org/w/index.php?title=Point_cloud&oldid=472583138)).

Smith et al.; U.S. Appl. No. 14/526,186 entitled "Universal multiple aperture medical ultrasound probe," filed Oct. 28, 2014.

Smith et al.; U.S. Appl. No. 14/595,083 entitled "Concave ultrasound transducers and 3D arrays," filed Jan. 12, 2015.

Smith et al.; U.S. Appl. No. 14/210,015 entitled "Alignment of ultrasound transducer arrays and multiple aperture probe assembly," filed Mar. 13, 2014.

Specht et al.; U.S. Appl. No. 14/279,052 entitled "Ultrasound imaging using apparent point-source transmit transducer," filed May 15, 2014.

Cristianini et al.; *An Introduction to Support Vector Machines*; Cambridge University Press; pp. 93-111; Mar. 2000.

Du et al.; User parameter free approaches to multistatic adaptive ultrasound imaging; 5th IEEE International Symposium; pp. 1287-1290, May 2008.

Feigenbaum, Harvey, M.D.; *Echocardiography*; Lippincott Williams & Wilkins; Philadelphia; 5th Ed.; pp. 428, 484; Feb. 1994.

Haykin, Simon; *Neural Networks: A Comprehensive Foundation* (2nd Ed.); Prentice Hall; pp. 156-187; Jul. 16, 1998.

Kramb et al.; Considerations for using phased array ultrasonics in a fully automated inspection system. *Review of Quantitative Nondestructive Evaluation*, vol. 23, ed. D. O. Thompson and D. E. Chimenti, pp. 817-825, (year of publication is sufficiently earlier than the effective U.S. filed and any foreign priority date) 2004.

Ledesma-Carbayo et al.; Spatio-temporal nonrigid registration for ultrasound cardiac motion estimation; *IEEE Trans. On Medical Imaging*; vol. 24; No. 9; Sep. 2005.

Leotta et al.; Quantitative three-dimensional echocardiography by rapid imaging . . . ; *J American Society of Echocardiography*; vol. 10; No. 8; ppl 830-839; Oct. 1997.

Morrison et al.; A probabilistic neural network based image segmentation network for magnetic resonance images; *Proc. Conf. Neural Networks*; Baltimore, MD; vol. 3; pp. 60-65; Jun. 1992.

Nadkarni et al.; Cardiac motion synchronization for 3D cardiac ultrasound imaging; Ph.D. Dissertation, University of Western Ontario; Jun. 2002.

Press et al.; Cubic spline interpolation; §3.3 in "Numerical Recipes in FORTRAN: The Art of Scientific Computing", 2nd Ed.; Cambridge, England; Cambridge University Press; pp. 107-110; Sep. 1992.

Sakas et al.; Preprocessing and volume rendering of 3D ultrasonic data; *IEEE Computer Graphics and Applications*; pp. 47-54, Jul. 1995.

Sapia et al.; Deconvolution of ultrasonic waveforms using an adaptive wiener filter; *Review of Progress in Quantitative Nondestructive Evaluation*; vol. 13A; Plenum Press; pp. 855-862; (year of publication is sufficiently earlier than the effective U.S. filing date and any foreign priority date) 1994.

Sapia et al.; Ultrasound image deconvolution using adaptive inverse filtering; 12 IEEE Symposium on Computer-Based Medical Systems, CBMS, pp. 248-253; Jun. 1999.

Sapia, Mark Angelo; Multi-dimensional deconvolution of optical microscope and ultrasound imaging using adaptive least-mean-square (LMS) inverse filtering; Ph.D. Dissertation; University of Connecticut; Jan. 2000.

Smith et al.; High-speed ultrasound volumetric imaging system. 1. Transducer design and beam steering; *IEEE Trans. Ultrason., Ferroelect., Freq. Contr.*; vol. 38; pp. 100-108; Mar. 1991.

Specht et al.; Deconvolution techniques for digital longitudinal tomography; *SPIE*; vol. 454; presented at Application of Optical Instrumentation in Medicine XII; pp. 319-325; Jun. 1984.

Specht et al.; Experience with adaptive PNN and adaptive GRNN; *Proc. IEEE International Joint Conf. on Neural Networks*; vol. 2; pp. 1203-1208; Orlando, FL; Jun. 1994.

Specht, D.F.; A general regression neural network; *IEEE Trans. On Neural Networks*; vol. 2.; No. 6; Nov. 1991.

Specht, D.F.; Blind deconvolution of motion blur using LMS inverse filtering; Lockheed Independent Research (unpublished); Jun. 23, 1975.

Specht, D.F.; Enhancements to probabilistic neural networks; *Proc. IEEE International Joint Conf. on Neural Networks*; Baltimore, MD; Jun. 1992.

Specht, D.F.; GRNN with double clustering; *Proc. IEEE International Joint Conf. Neural Networks*; Vancouver, Canada; Jul. 16-21, 2006.

Specht, D.F.; Probabilistic neural networks; Pergamon Press; *Neural Networks*; vol. 3; pp. 109-118; Feb. 1990.

Von Ramm et al.; High-speed ultrasound volumetric imaging—System. 2. Parallel processing and image display; *IEEE Trans. Ultrason., Ferroelect., Freq. Contr.*; vol. 38; pp. 109-115; Mar. 1991.

Wells, P.N.T.; *Biomedical ultrasonics*; Academic Press; London, New York, San Francisco; pp. 124-125; Mar. 1977.

Widrow et al.; Adaptive signal processing; Prentice-Hall; Englewood Cliffs, NJ; pp. 99-116; Mar. 1985.

Specht et al.; U.S. Appl. No. 13/773,340 entitled "Determining Material Stiffness Using Multiple Aperture Ultrasound," filed Feb. 21, 2013.

Call et al.; U.S. Appl. No. 13/850,823 entitled "Systems and methods for improving ultrasound image quality by applying weighting factors," filed Mar. 26, 2013.

Specht et al.; U.S. Appl. No. 14/078,311 entitled "Imaging with Multiple Aperture Medical Ultrasound and Synchronization of Add-On Systems," filed Nov. 12, 2013.

Specht, D. F.; U.S. Appl. No. 14/157,257 entitled "Method and Apparatus to Produce Ultrasonic Images Using Multiple Apertures," filed Jan. 16, 2014.

Li et al.; An efficient speckle tracking algorithm for ultrasonic imaging; 24; pp. 215-228; Oct. 1, 2002.

(56)

**References Cited**

## OTHER PUBLICATIONS

UCLA Academic Technology; SPSS learning module: How can I analyze a subset of my data; 6 pages; retrieved from the Internet ([http://www.ats.ucla.edu/stat/spss/modules/subset\\_analyze.htm](http://www.ats.ucla.edu/stat/spss/modules/subset_analyze.htm)) Nov. 26, 2001.

Wikipedia; Curve fitting; 5 pages; retrieved from the internet ([http://en.wikipedia.org/wiki/Curve\\_fitting](http://en.wikipedia.org/wiki/Curve_fitting)) Dec. 19, 2010.

Wikipedia; Speed of sound; 17 pages; retrieved from the Internet ([http://en.wikipedia.org/wiki/Speed\\_of\\_sound](http://en.wikipedia.org/wiki/Speed_of_sound)) Aug. 29, 2015.

Carson et al.; Measurement of photoacoustic transducer position by robotic source placement and nonlinear parameter estimation; Biomedical Optics (BIOS); International Society for Optics and Photonics (9th Conf. on Biomedical Thermoacoustics, Optoacoustics, and Acousto-optics; vol. 6856; 9 pages; Feb 28, 2008.

Chen et al.; Maximum-likelihood source localization and unknown sensor location estimation for wideband signals in the near-field; IEEE Transactions on Signal Processing; 50(8); pp. 1843-1854; Aug. 2002.

Chen et al.; Source localization and tracking of a wideband source using a randomly distributed beamforming sensor array; International Journal of High Performance Computing Applications; 16(3); pp. 259-272; Fall 2002.

Fernandez et al.; High resolution ultrasound beamforming using synthetic and adaptive imaging techniques; Proceedings IEEE Inter-

national Symposium on Biomedical Imaging; Washington, D.C.; pp. 433-436; Jul. 7-10, 2002.

Gazor et al.; Wideband multi-source beamforming with array location calibration and direction finding; Conference on Acoustics, Speech and Signal Processing Icassp-95; Detroit, MI; vol. 3 IEEE; pp. 1904-1907; May 9-12, 1995.

Heikkila et al.; A four-step camera calibration procedure with implicit image correction; Proceedings IEEE Computer Society Conference on Computer Vision and Pattern Recognition; San Juan; pp. 1106-1112; Jun. 17-19, 1997.

Hsu et al.; Real-time freehand 3D ultrasound calibration; CUED/F-INFENG/TR 565; Department of Engineering, University of Cambridge, United Kingdom; 14 pages; Sep. 2006.

Khamene et al.; A novel phantom-less spatial and temporal ultrasound calibration method; Medical Image Computing and Computer-Assisted Intervention—MICCAI (Proceedings 8th Int. Conf.); Springer Berlin Heidelberg; Palm Springs, CA; pp. 65-72; Oct. 26-29, 2005.

Slavine et al.; Construction, calibration and evaluation of a tissue phantom with reproducible optical properties for investigations in light emission tomography; Engineering in Medicine and Biology Workshop; Dallas, TX; IEEE pp. 122-125; Nov. 11-12, 2007.

Wang et al.; Photoacoustic tomography of biological tissues with high cross-section resolution: reconstruction and experiment; Medical Physics; 29(12); pp. 2799-2805; Dec. 2002.

\* cited by examiner

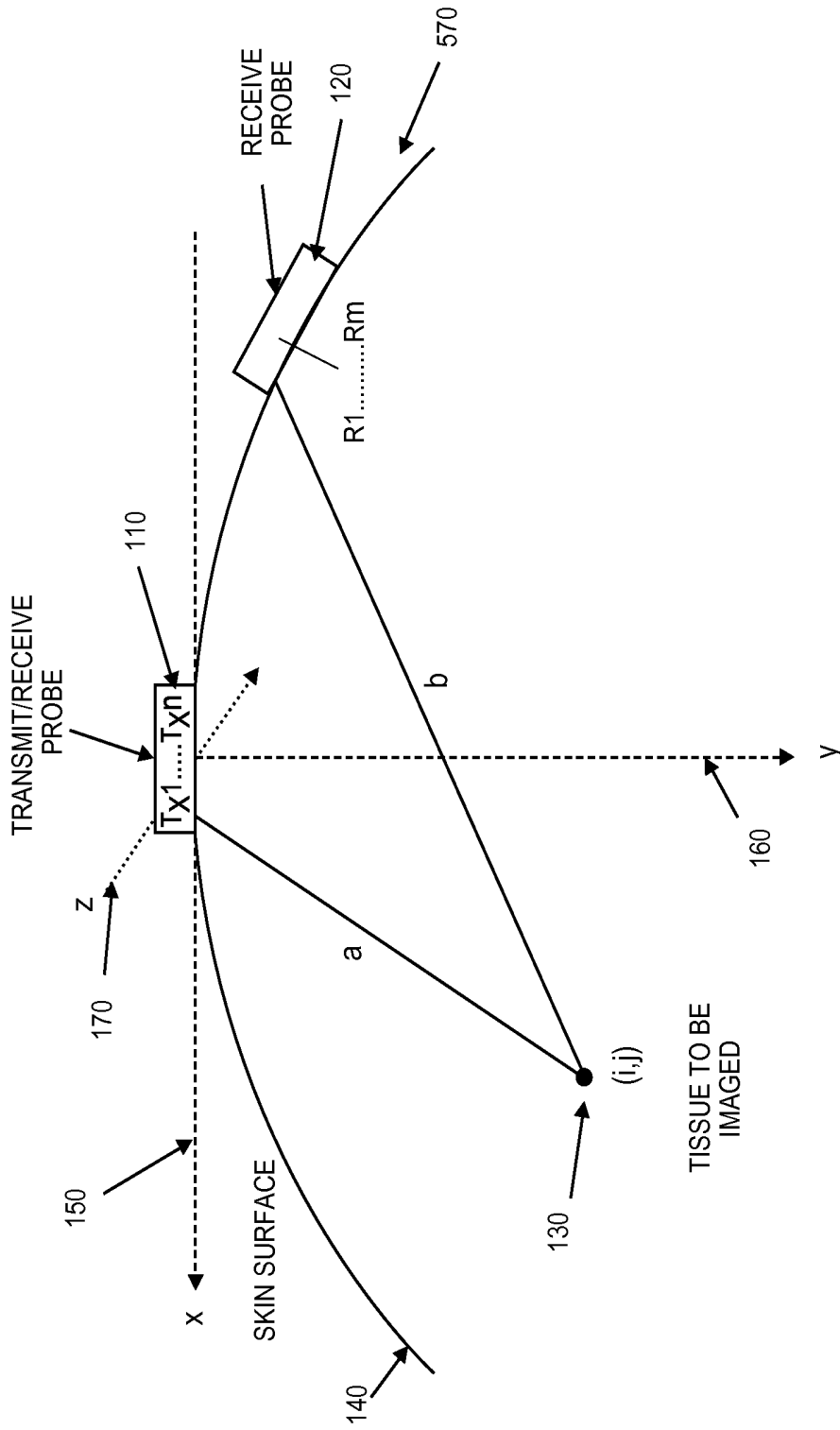

FIG. 1

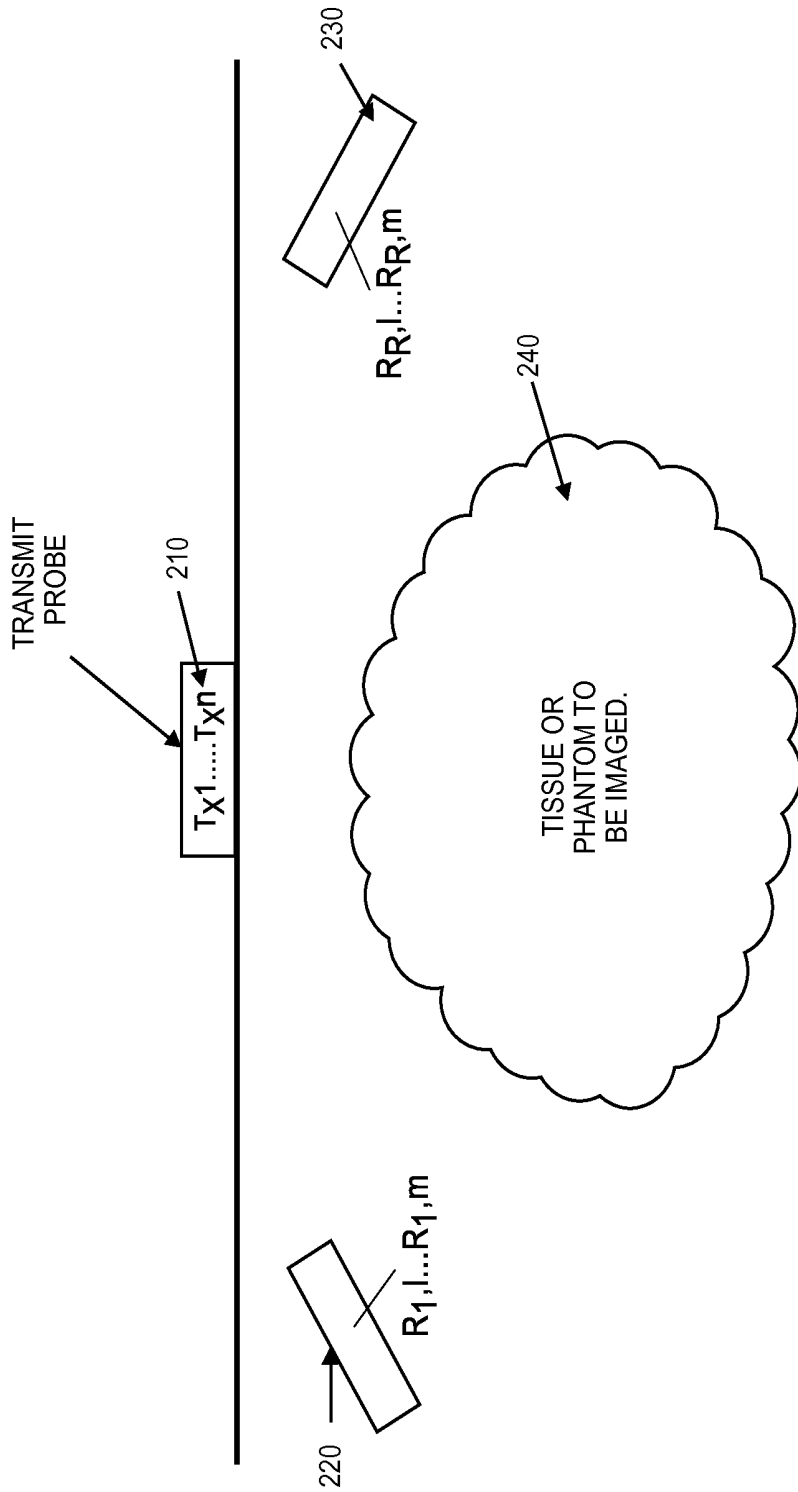

FIG. 2

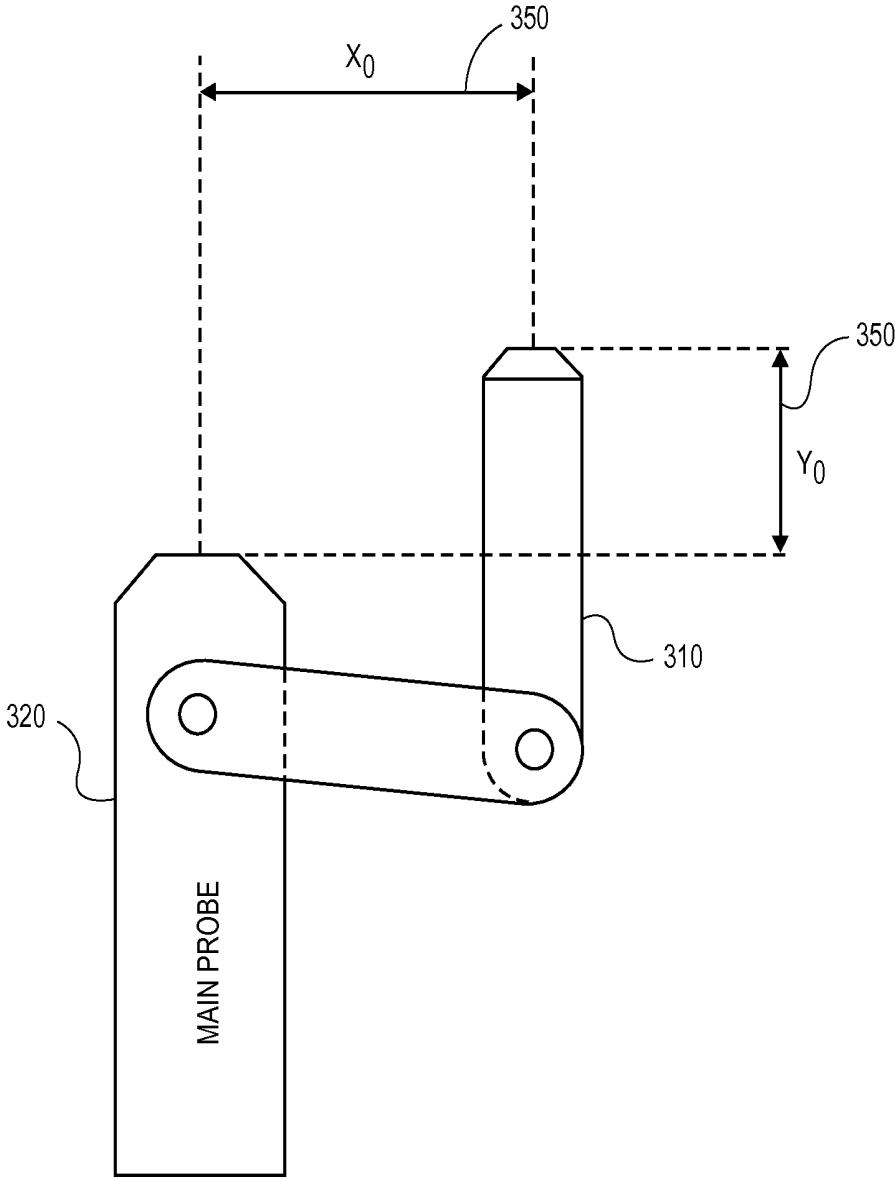

FIG. 3

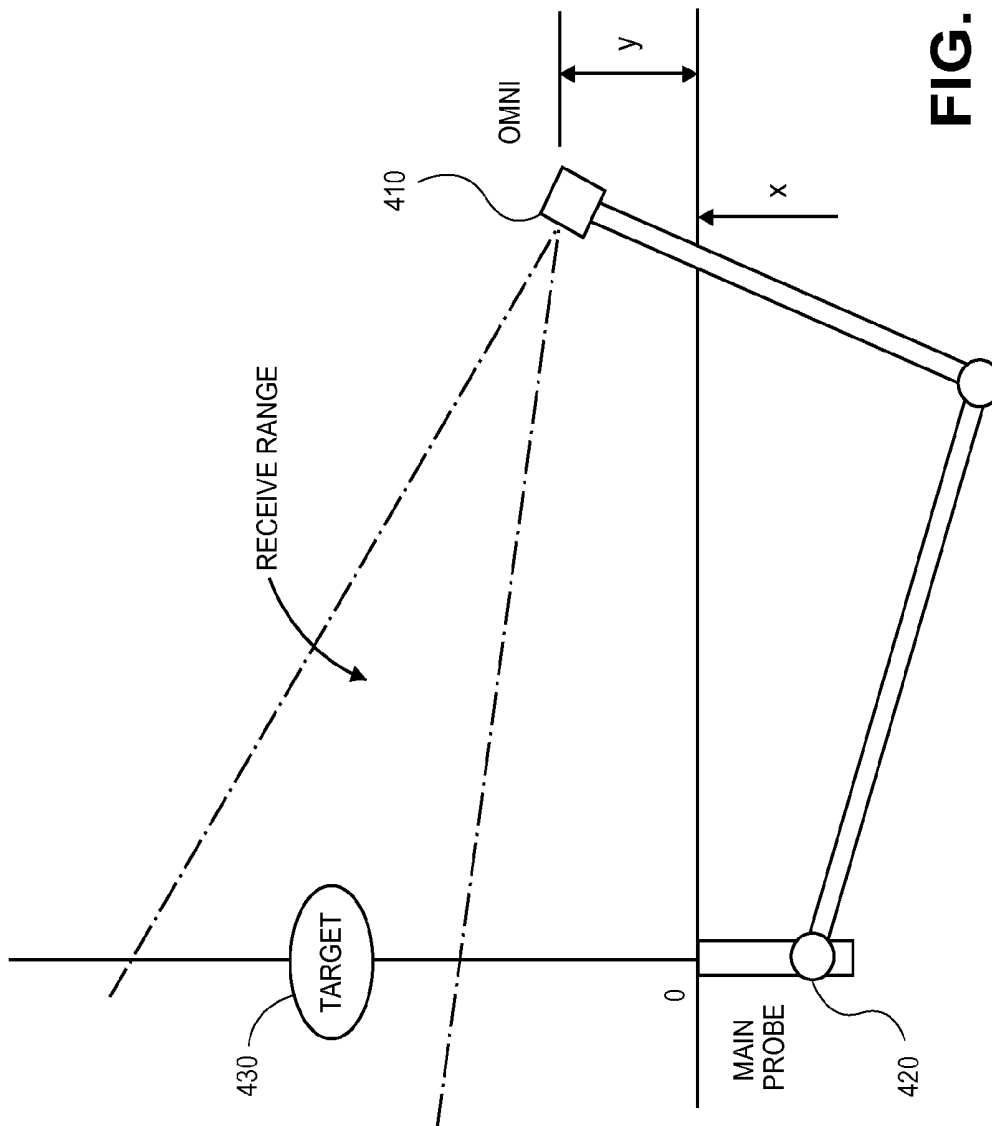

FIG. 4

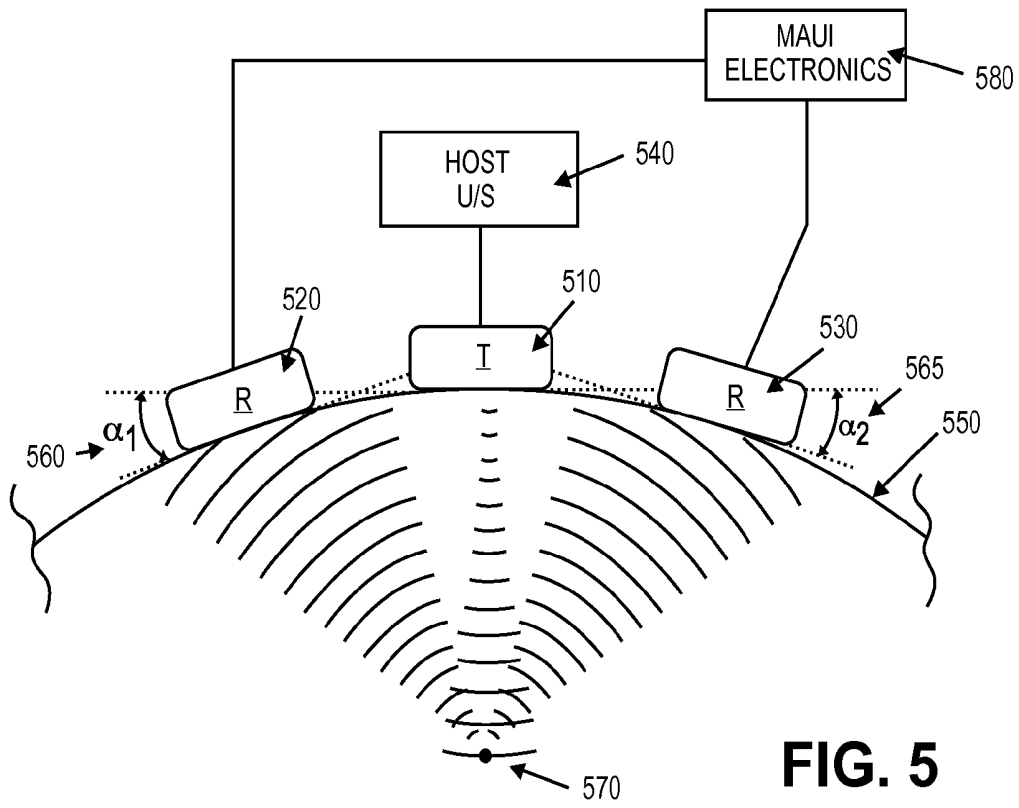

FIG. 5

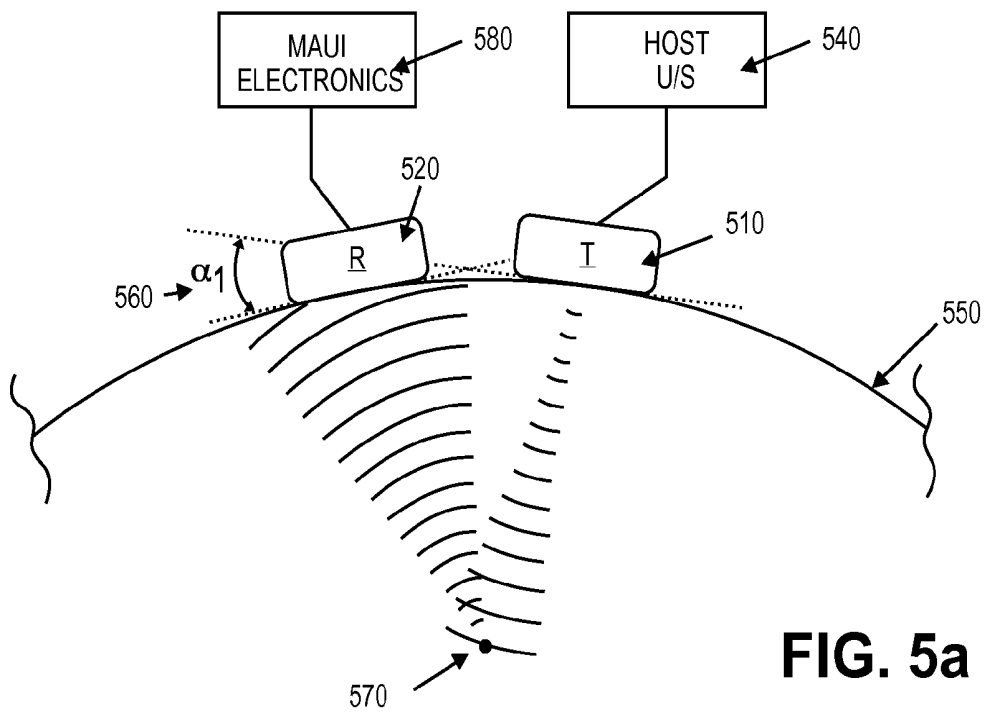

FIG. 5a

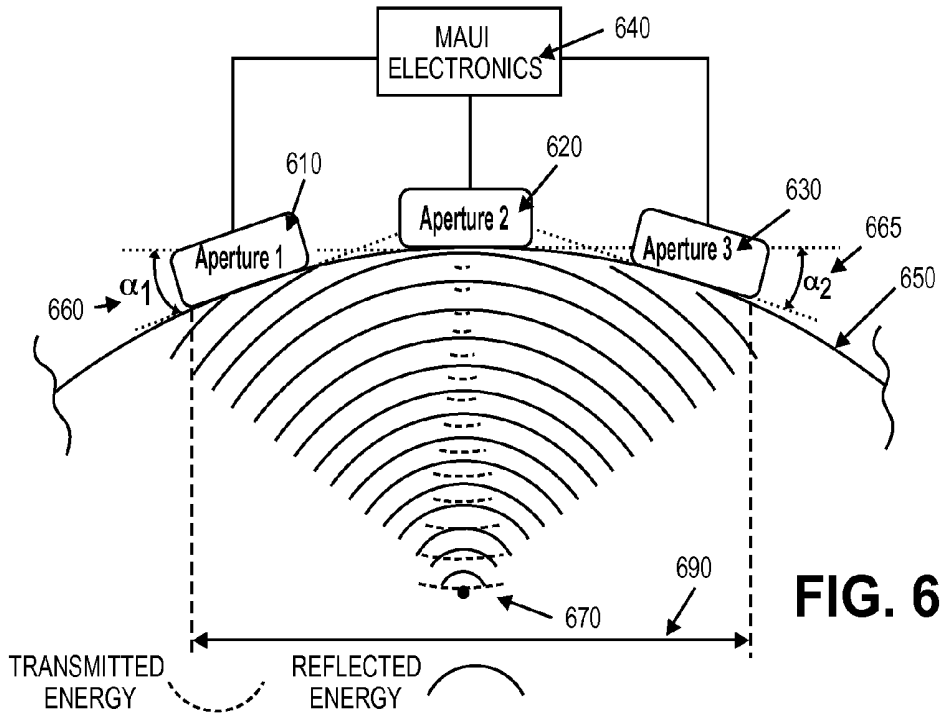

FIG. 6

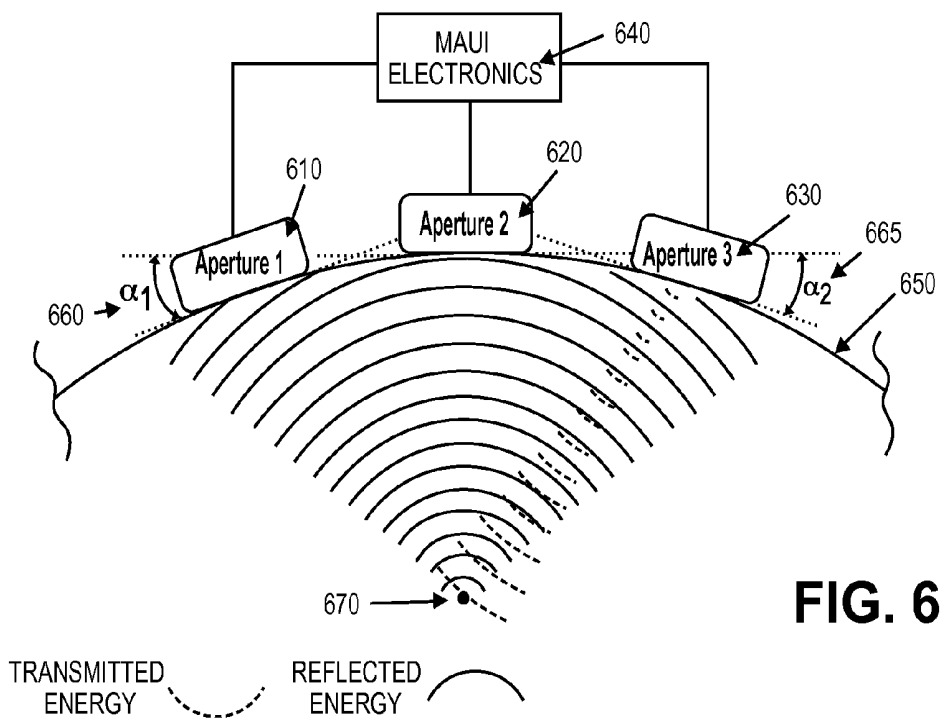

FIG. 6a

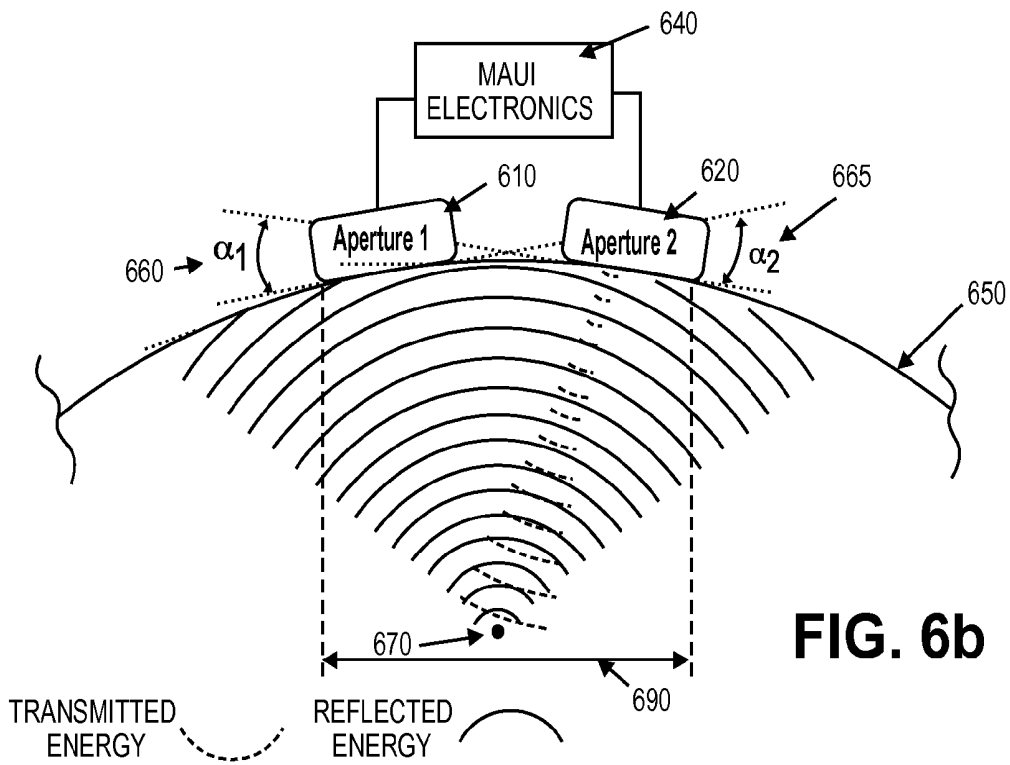

FIG. 6b

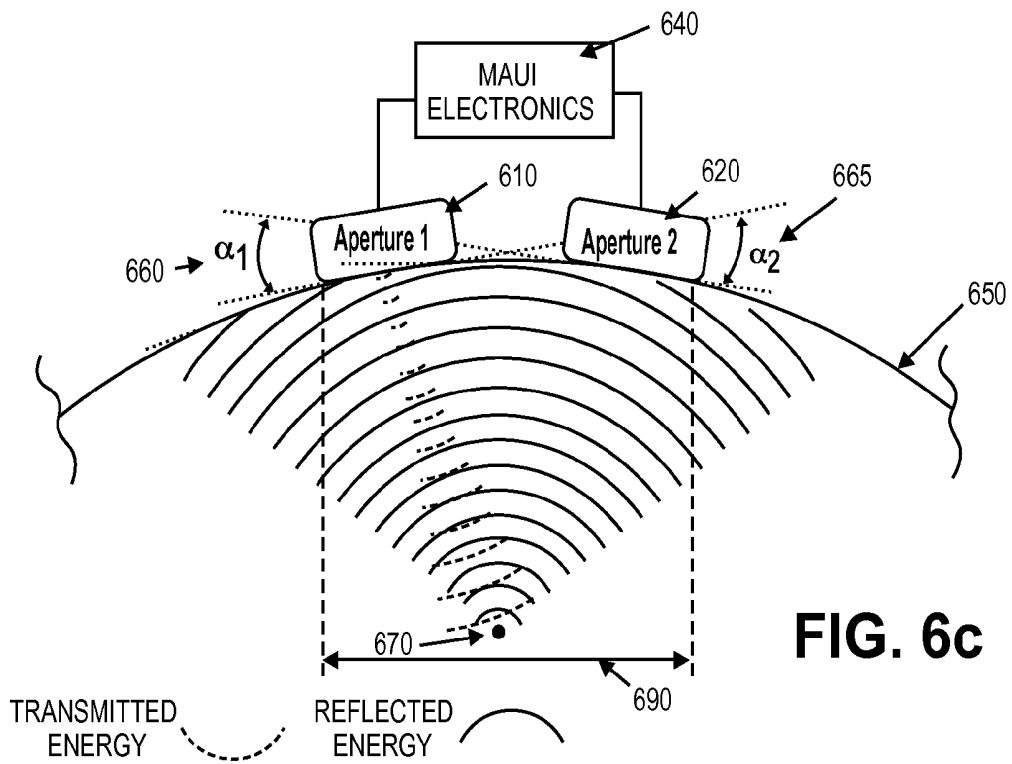

FIG. 6c

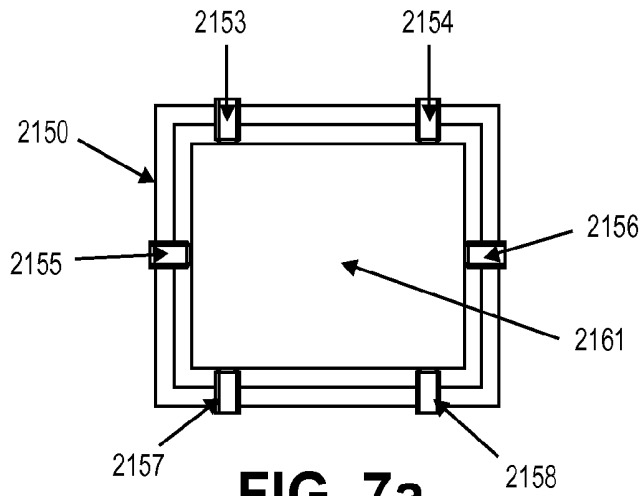

FIG. 7a

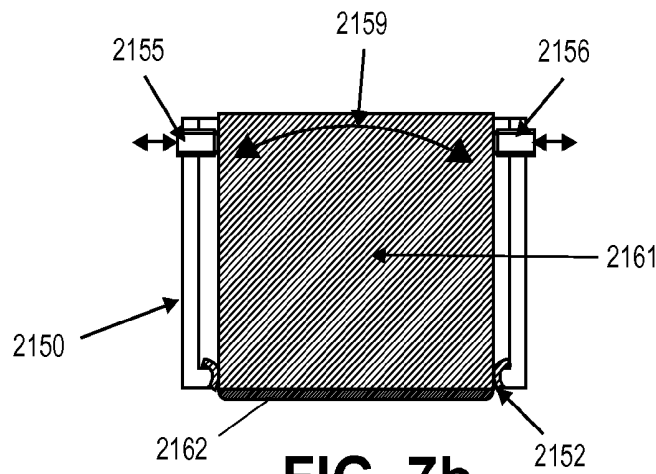

FIG. 7b

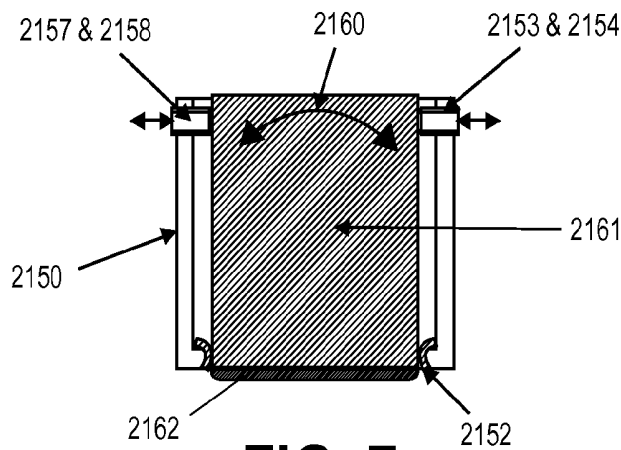

FIG. 7c

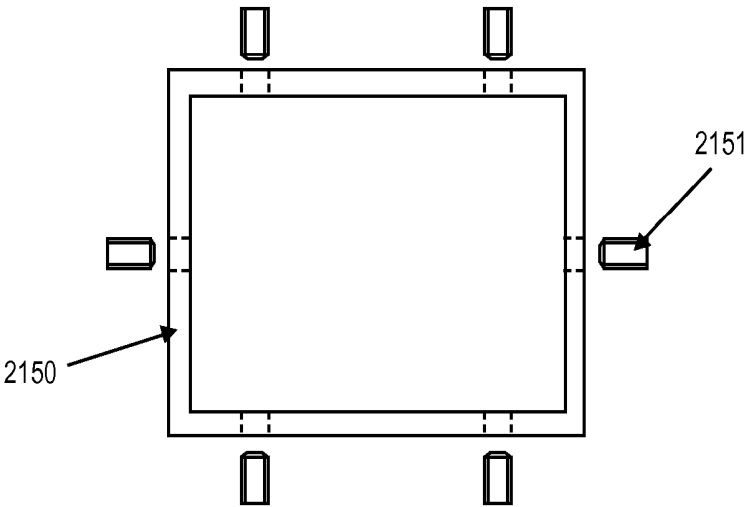

FIG. 8a

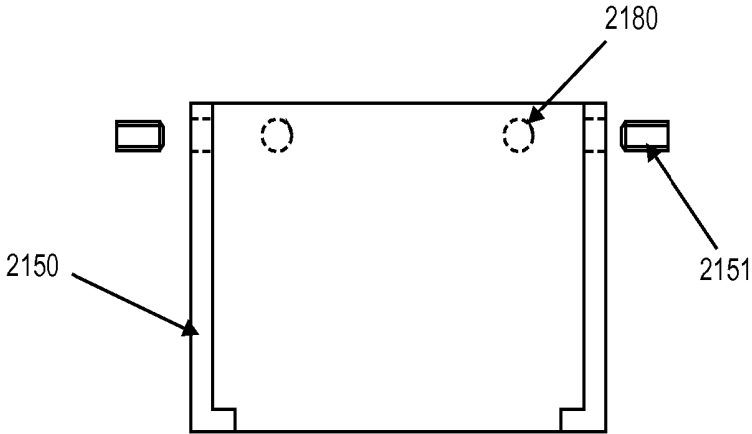

FIG. 8b

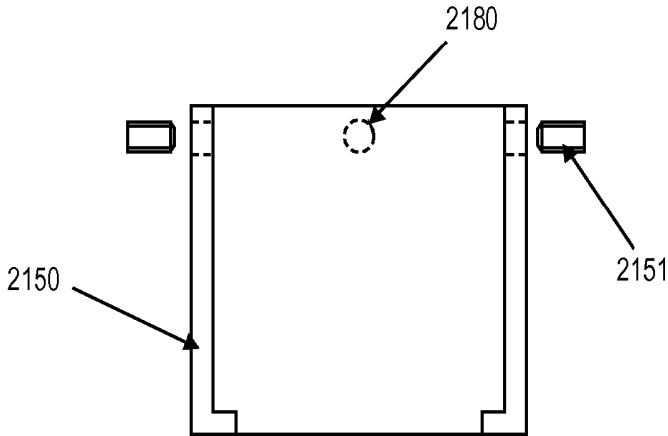

FIG. 8c

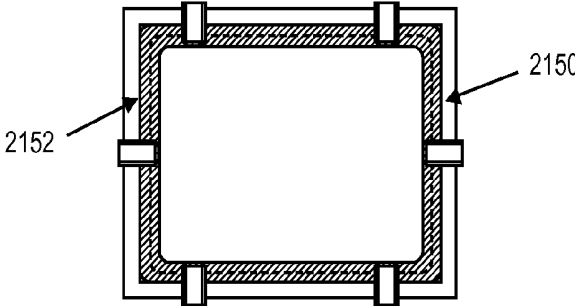

FIG. 9a

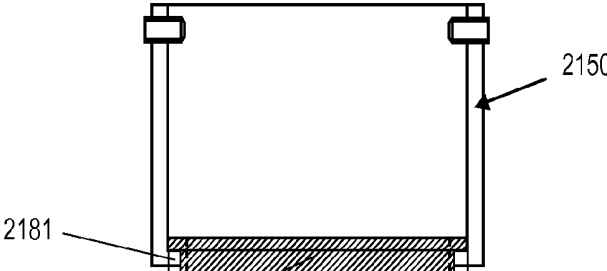

FIG. 9b

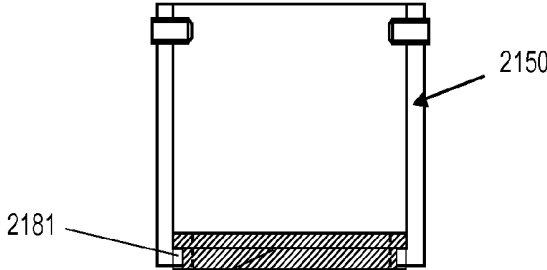

FIG. 9c

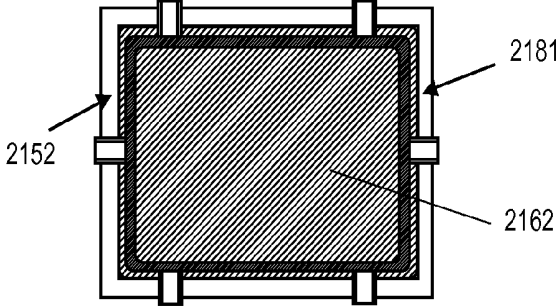

FIG. 9d

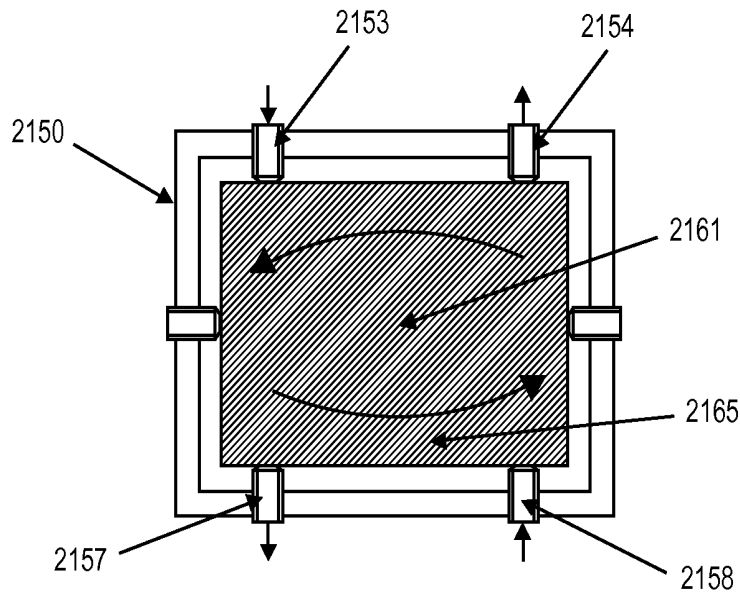

FIG. 10a

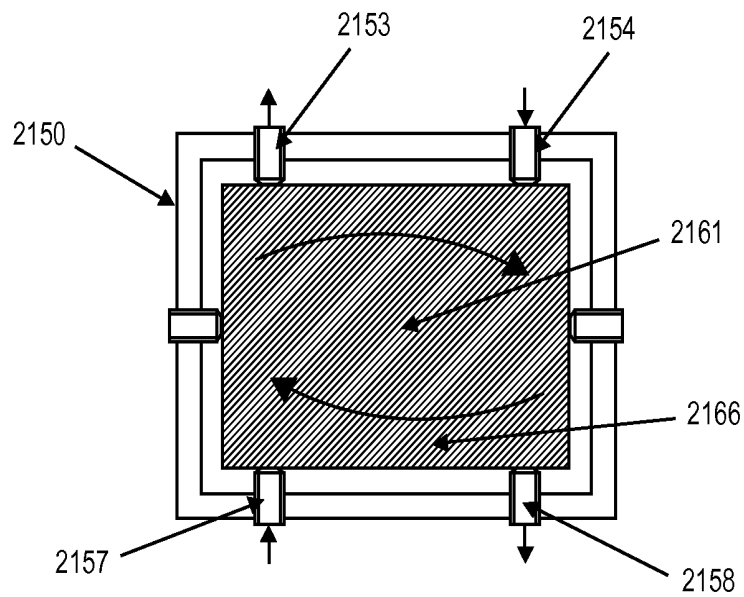

FIG. 10b

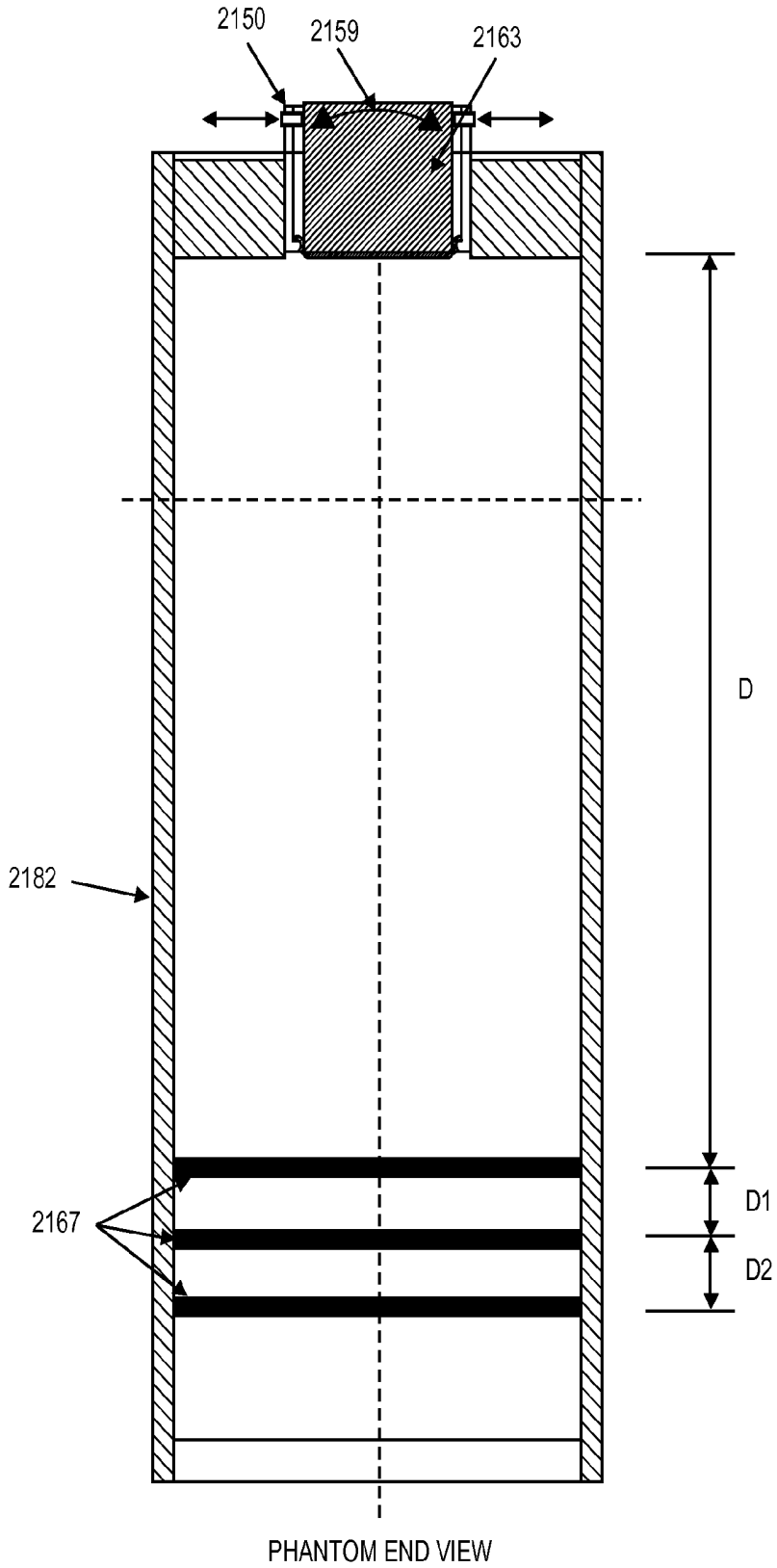

FIG. 11

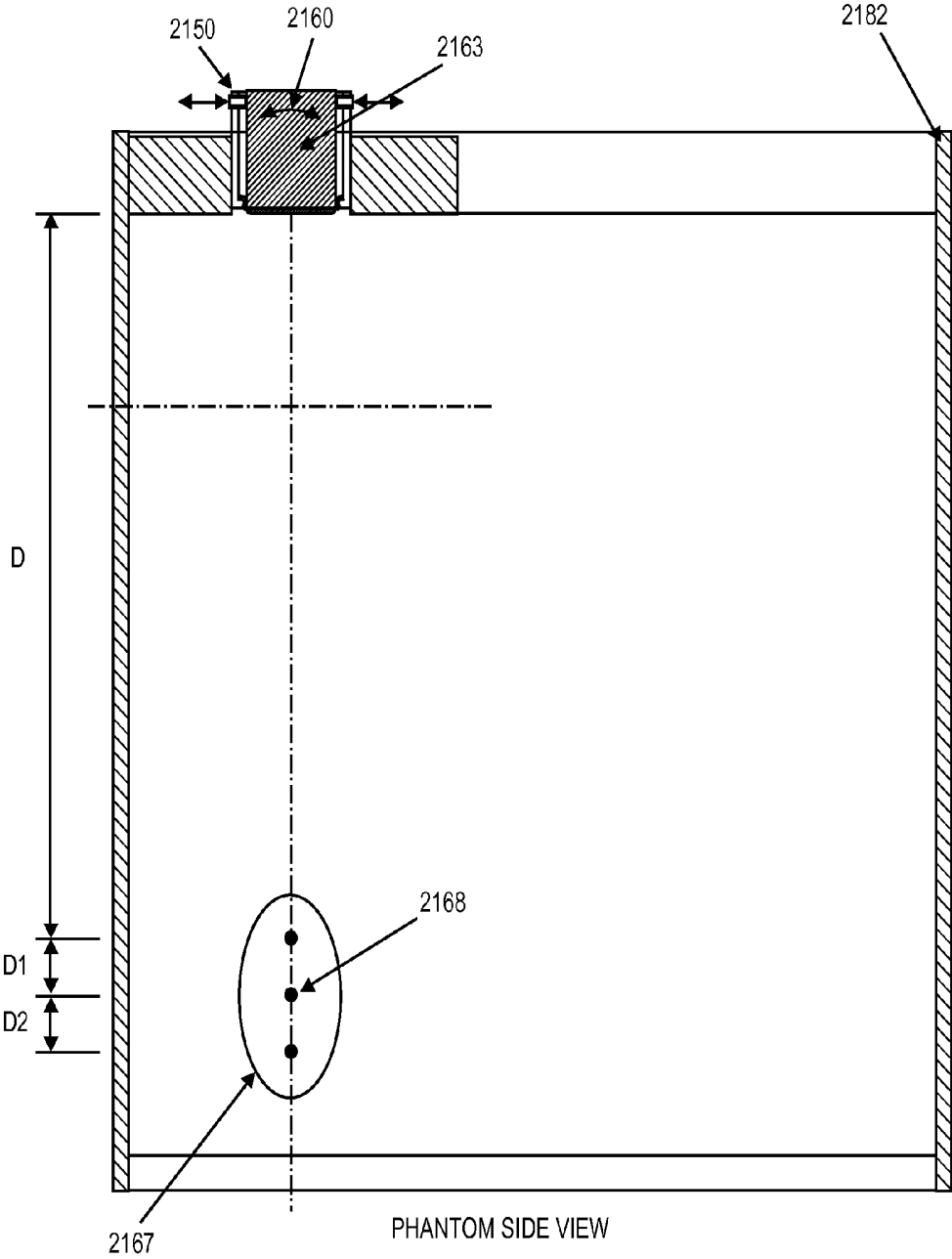

FIG. 12

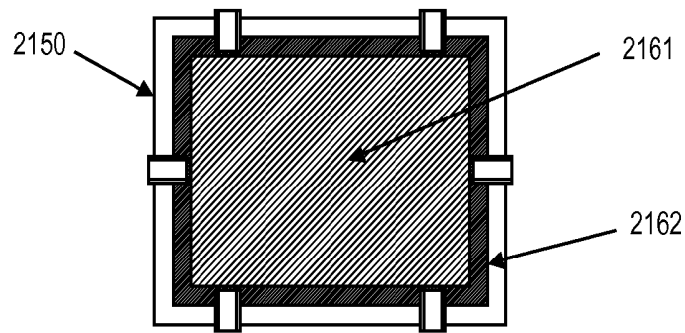

FIG. 13a

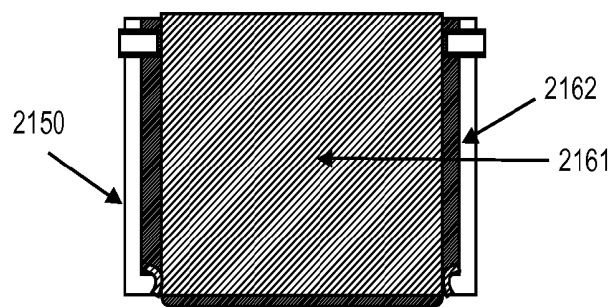

FIG. 13b

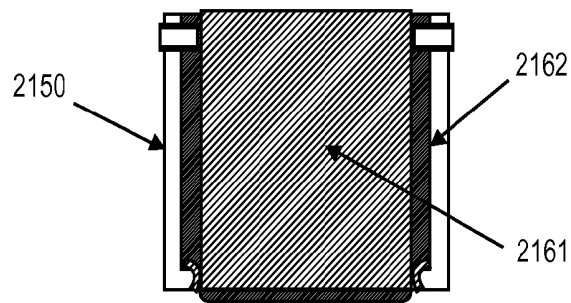

FIG. 13c

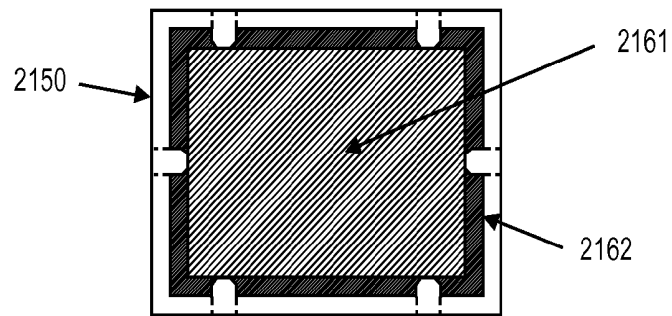

FIG. 14a

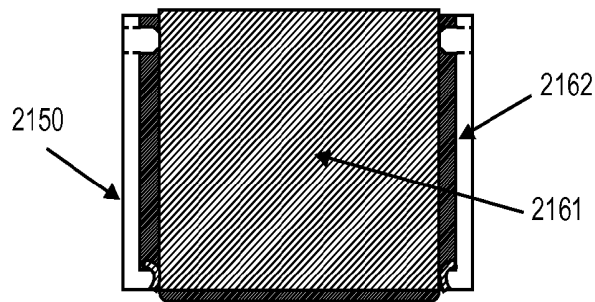

FIG. 14b

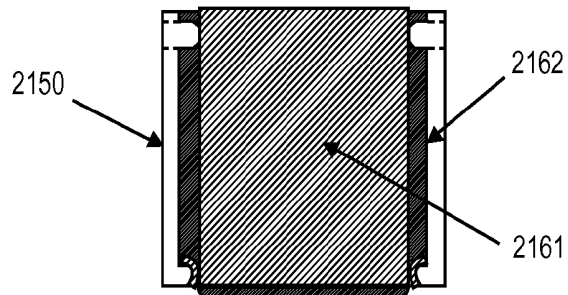
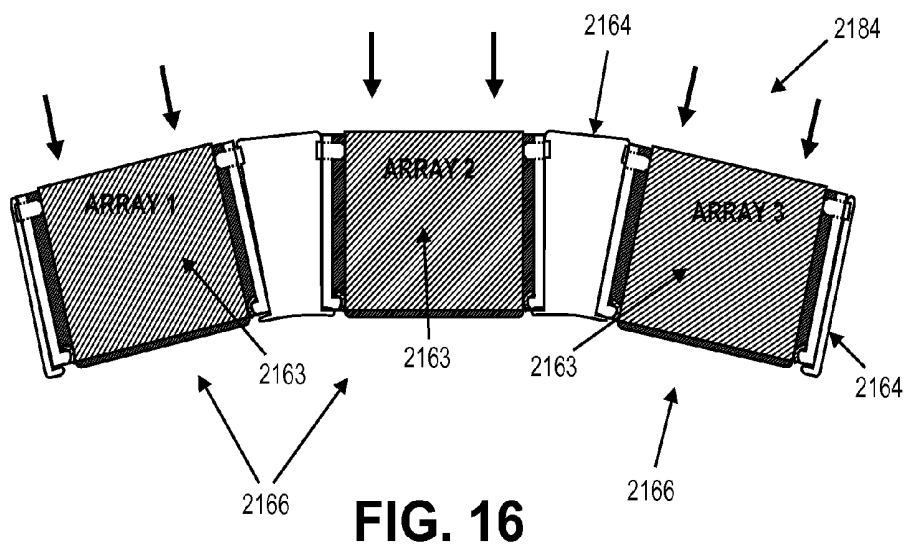
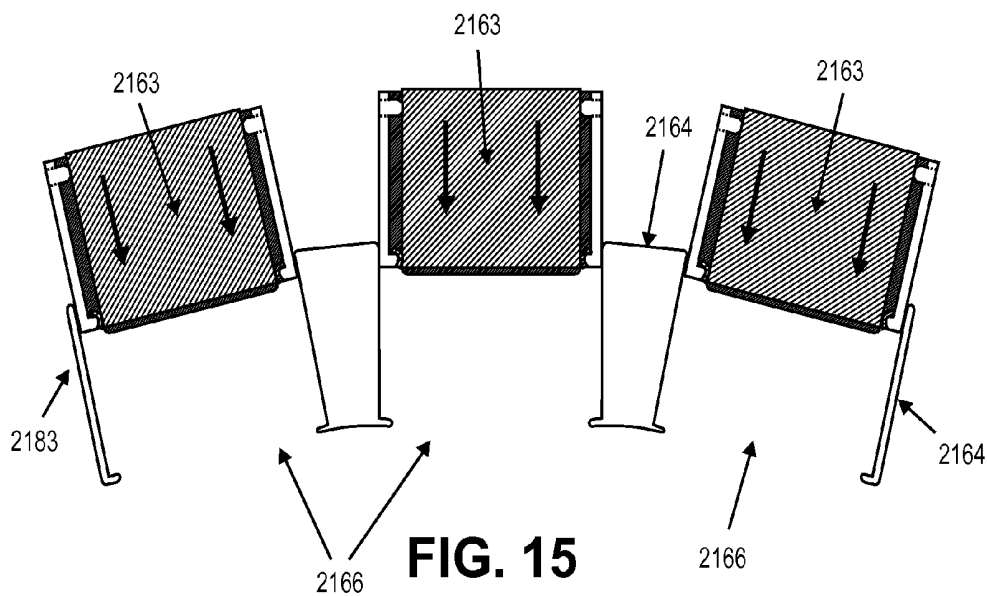

FIG. 14c



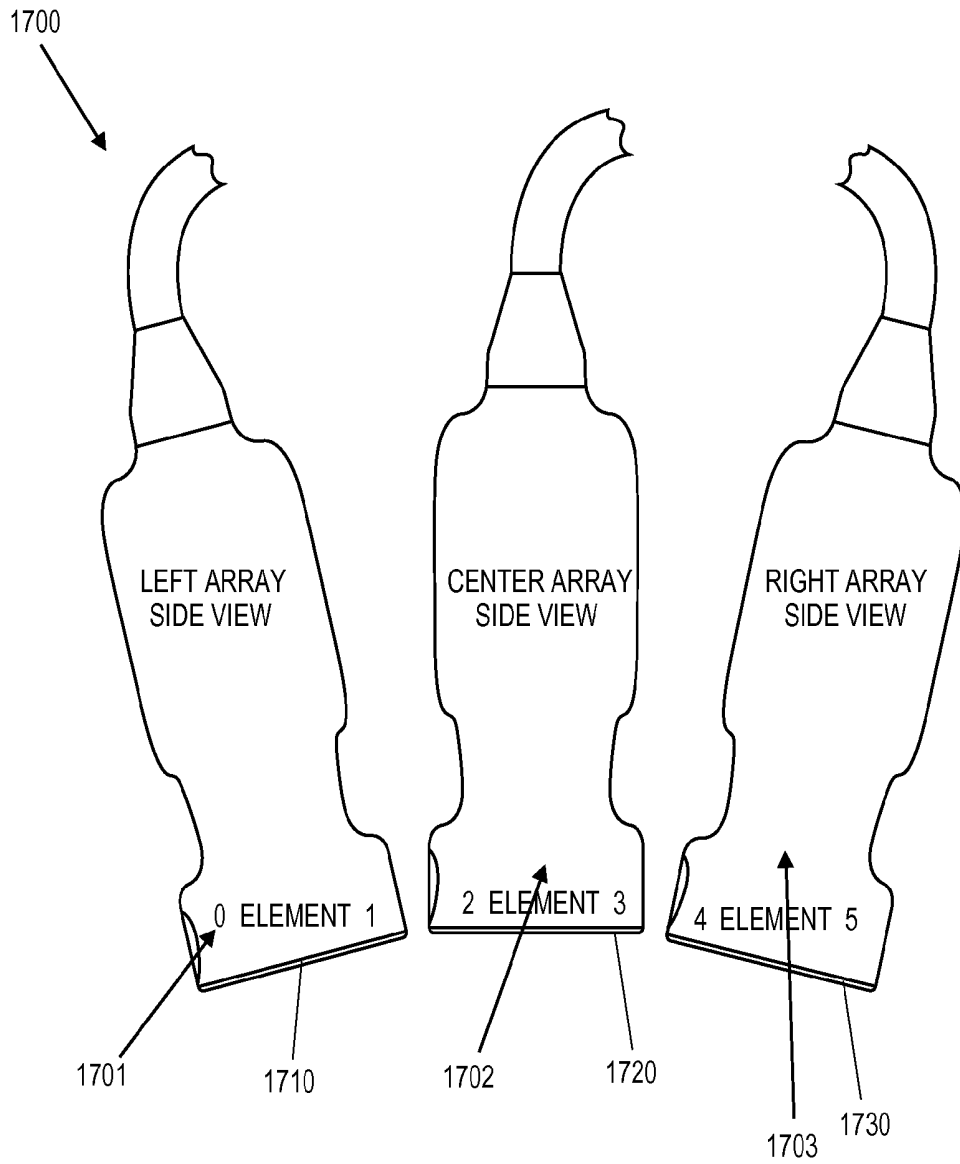

FIG. 17

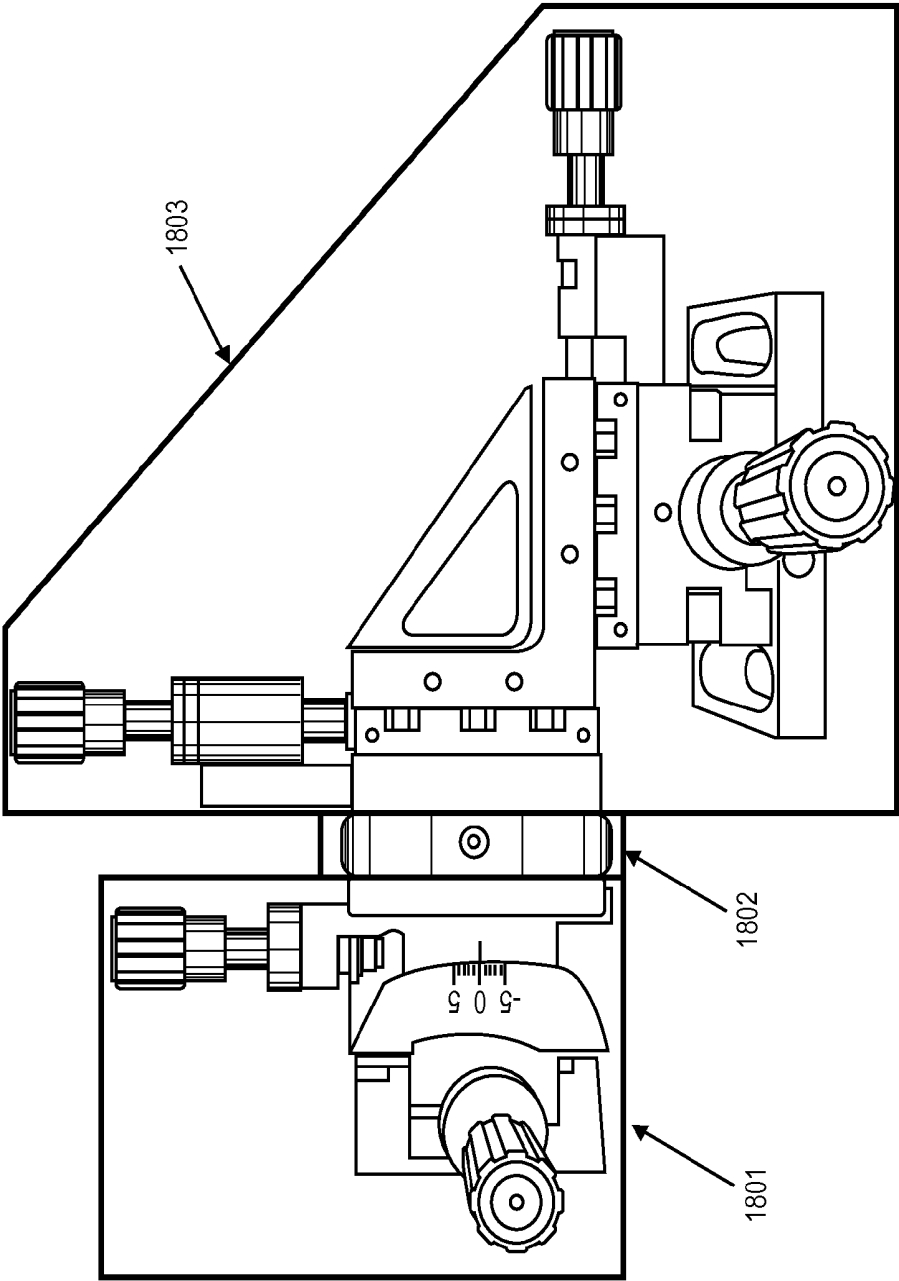

FIG. 18a

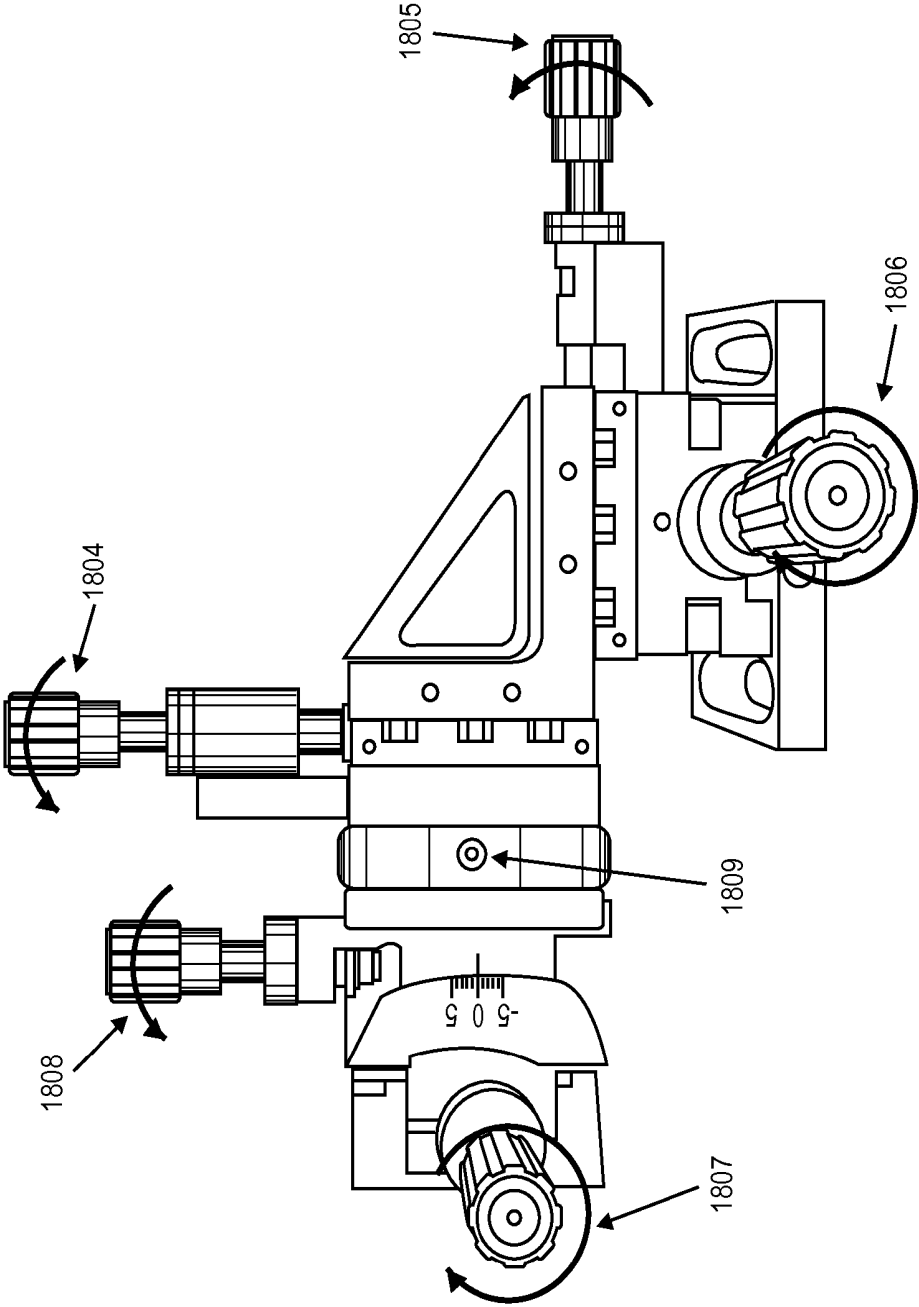

FIG. 18b

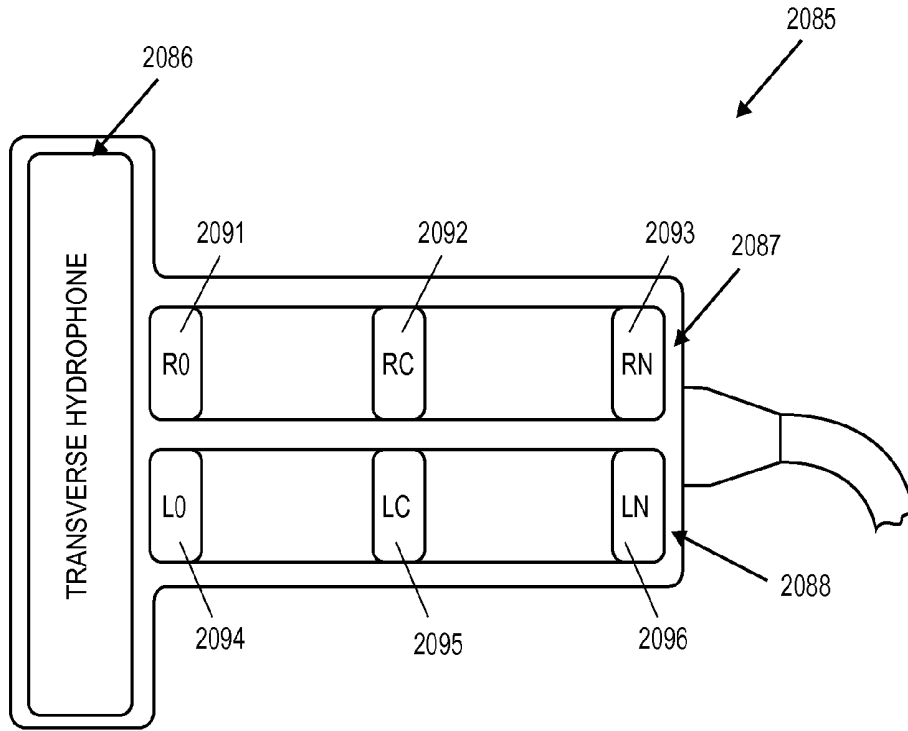

FIG. 19a

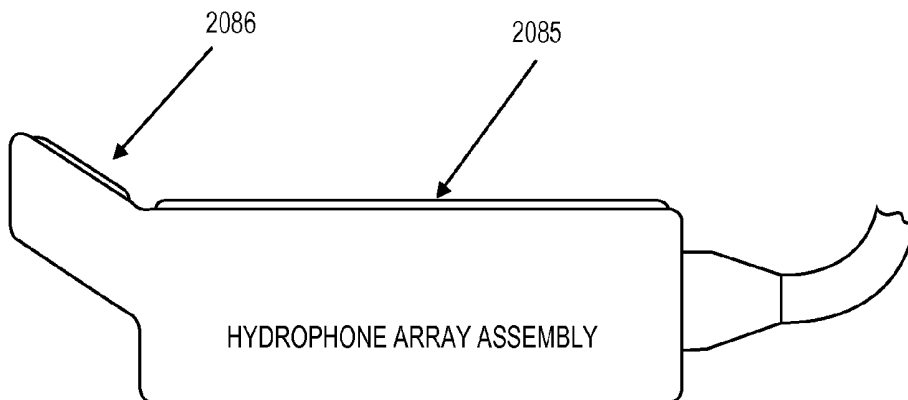
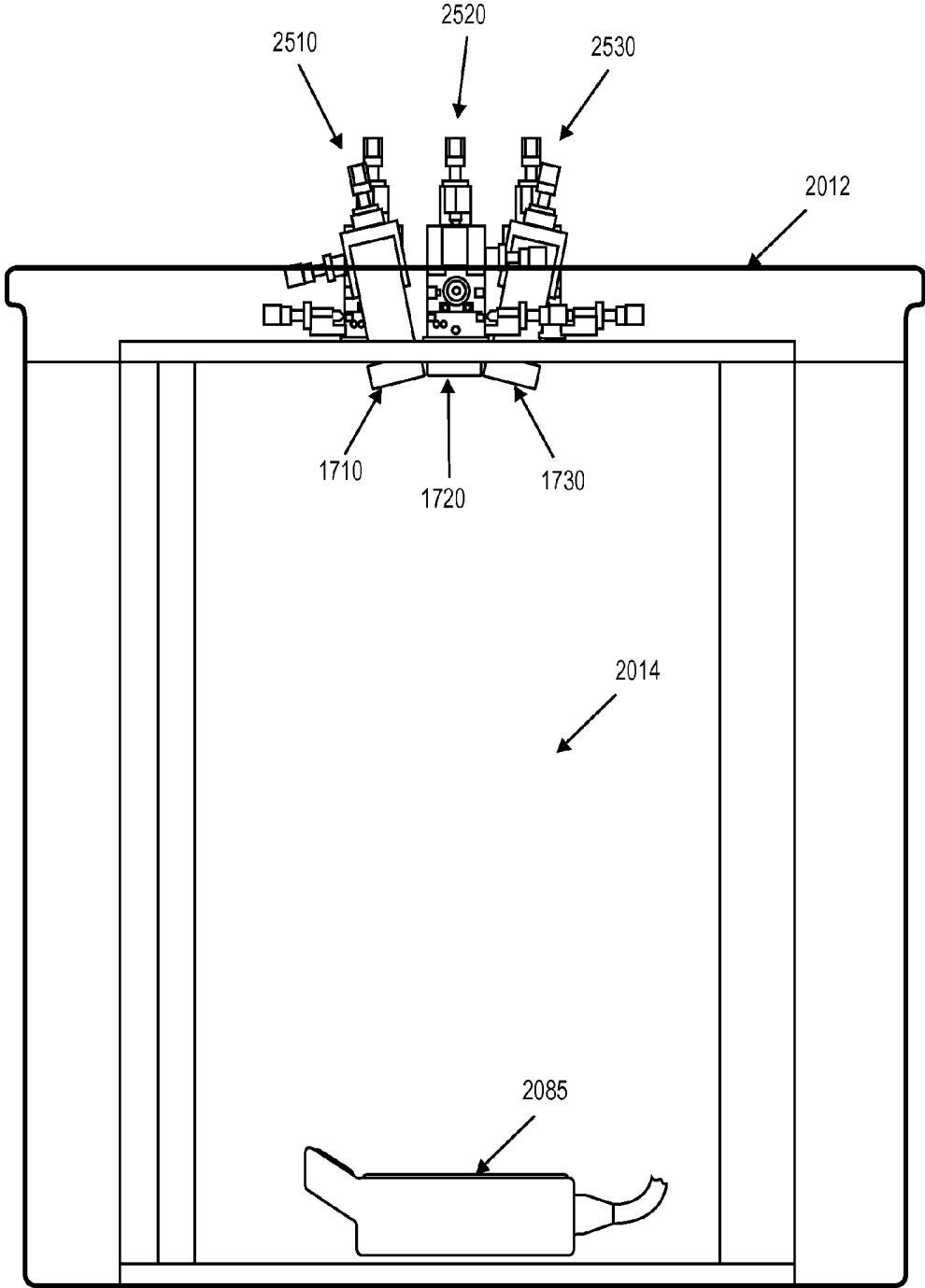

FIG. 19b



ASSEMBLED TEST FIXTURE IN TANK

**FIG. 20**

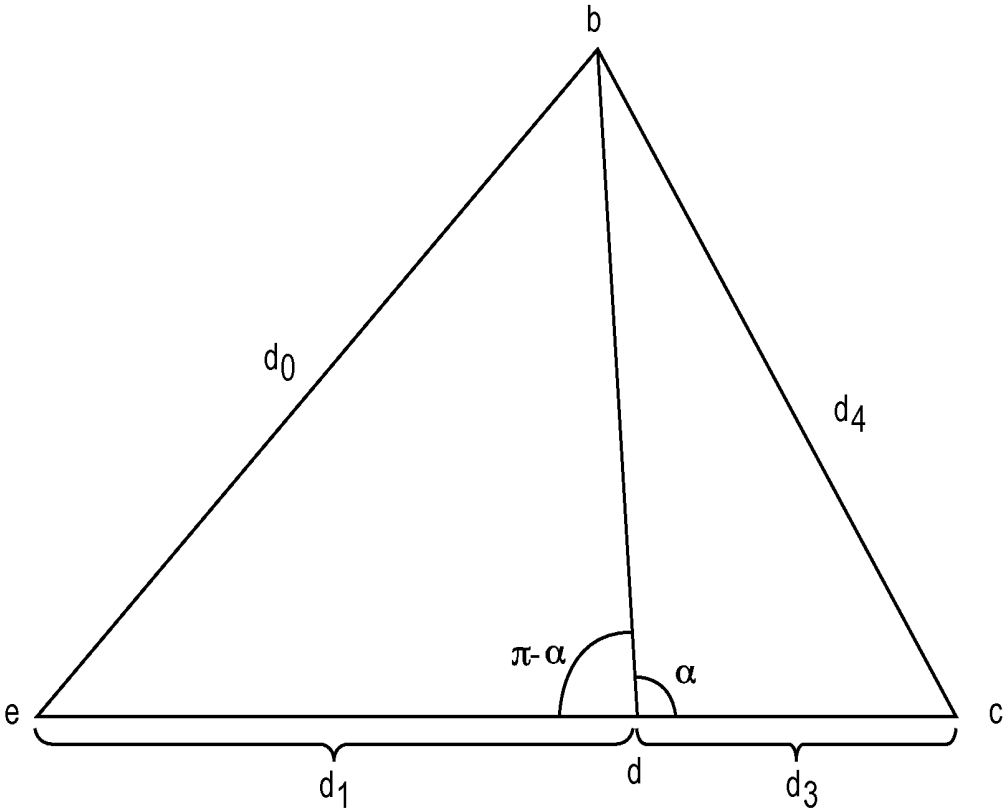
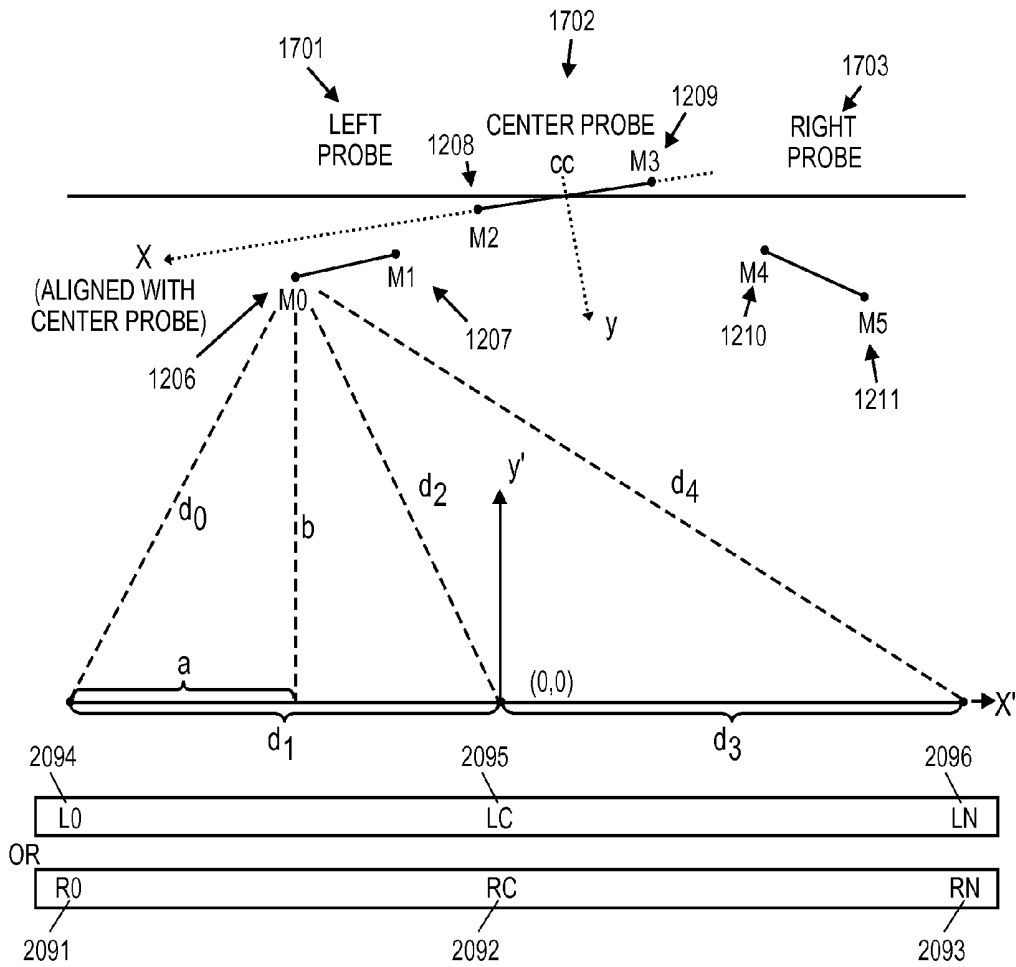

FIG. 21a



FIRST REFERENCE IS LC OR RC  
 FINAL REFERENCE IS CENTER OF CENTER PROBE (CC)

FIG. 21b

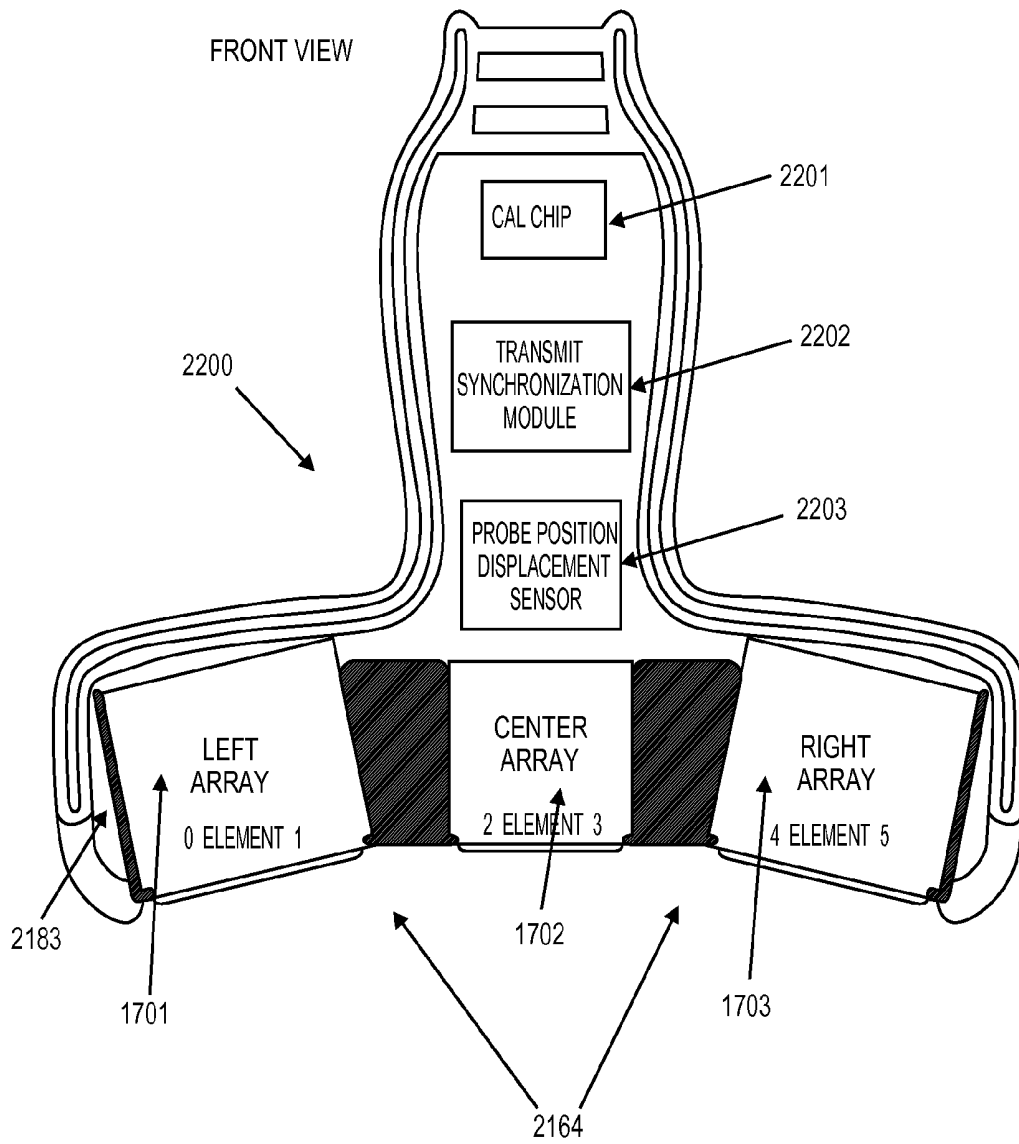

FIG. 22

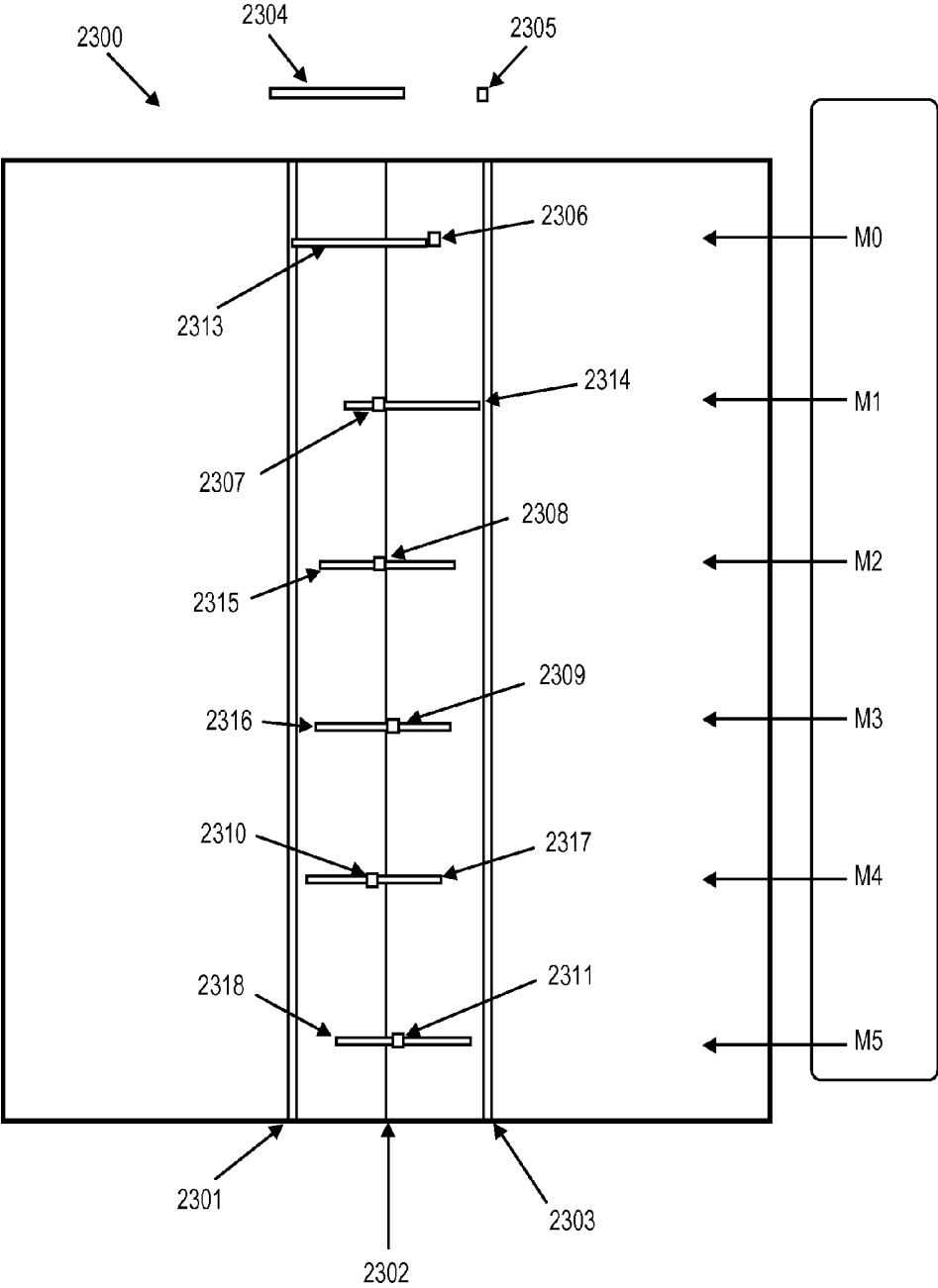

FIG. 23a

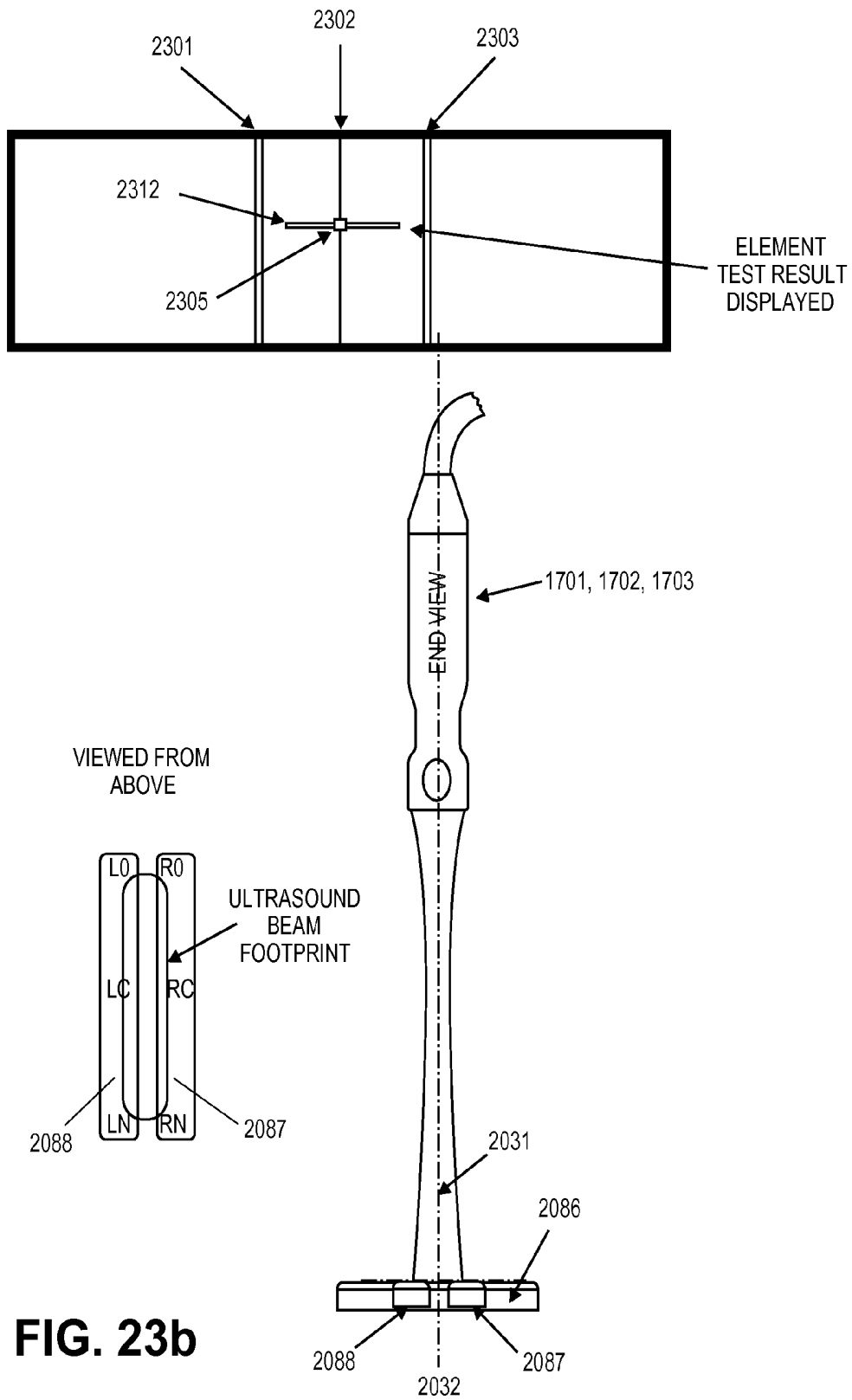

FIG. 23b

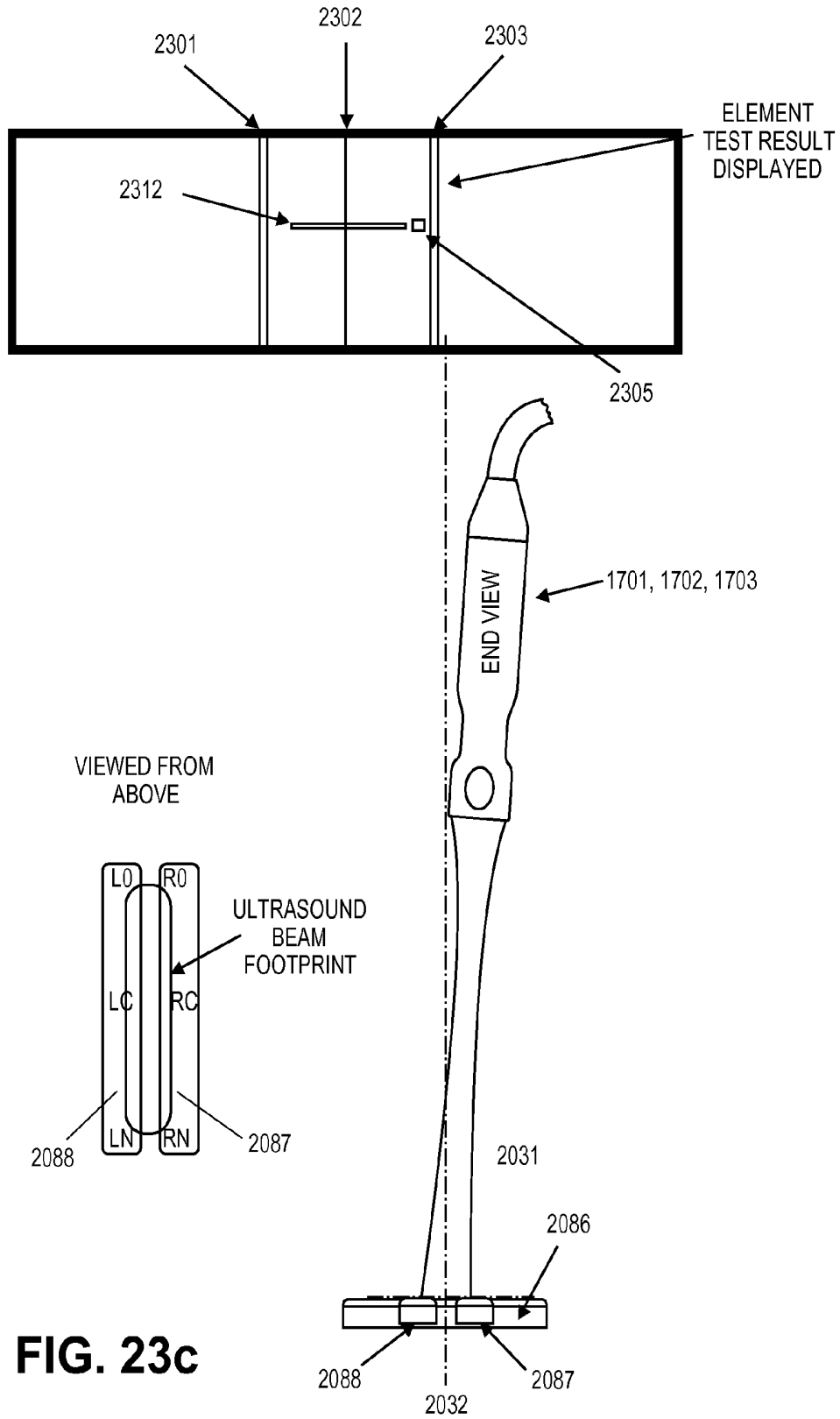

FIG. 23c

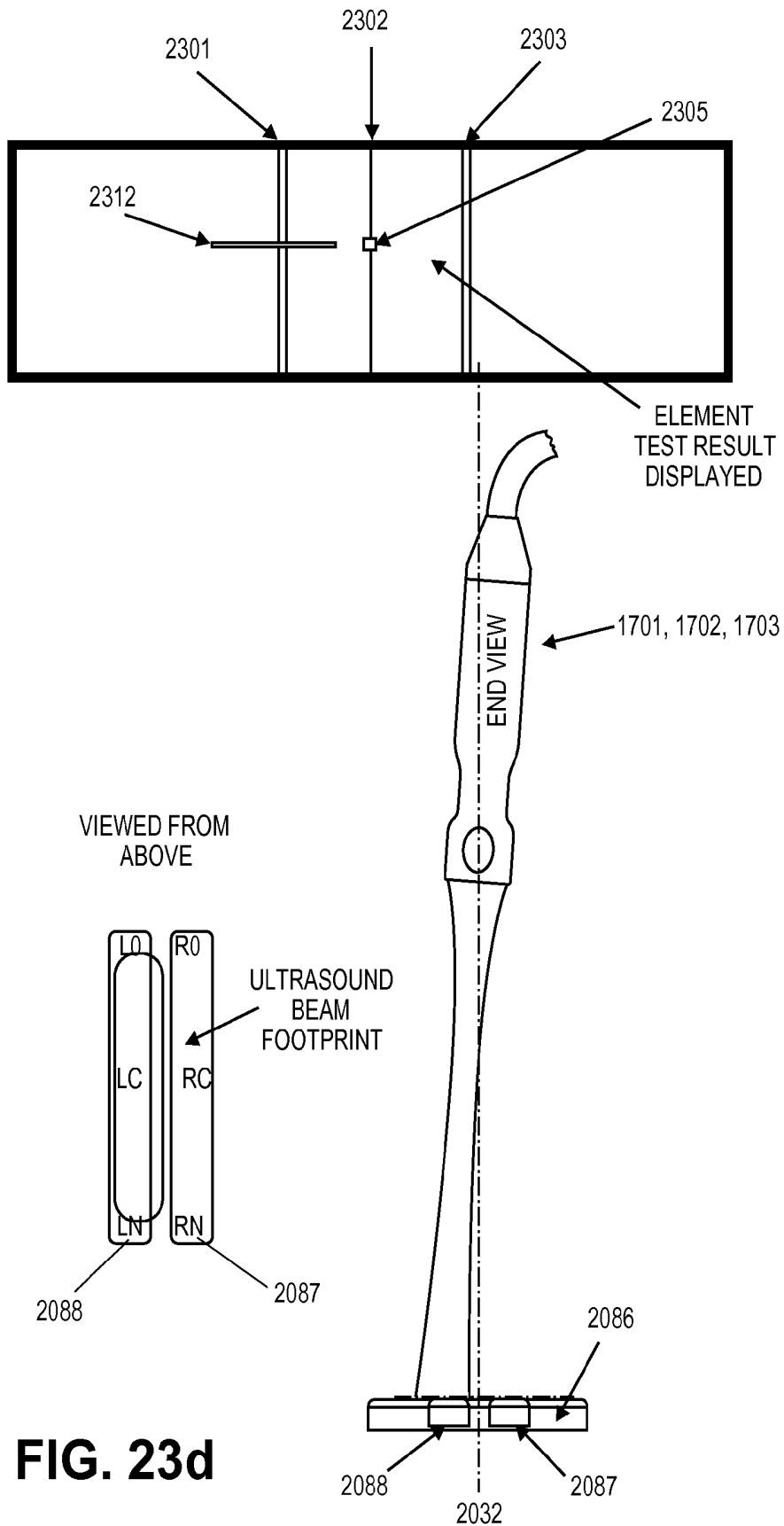

FIG. 23d

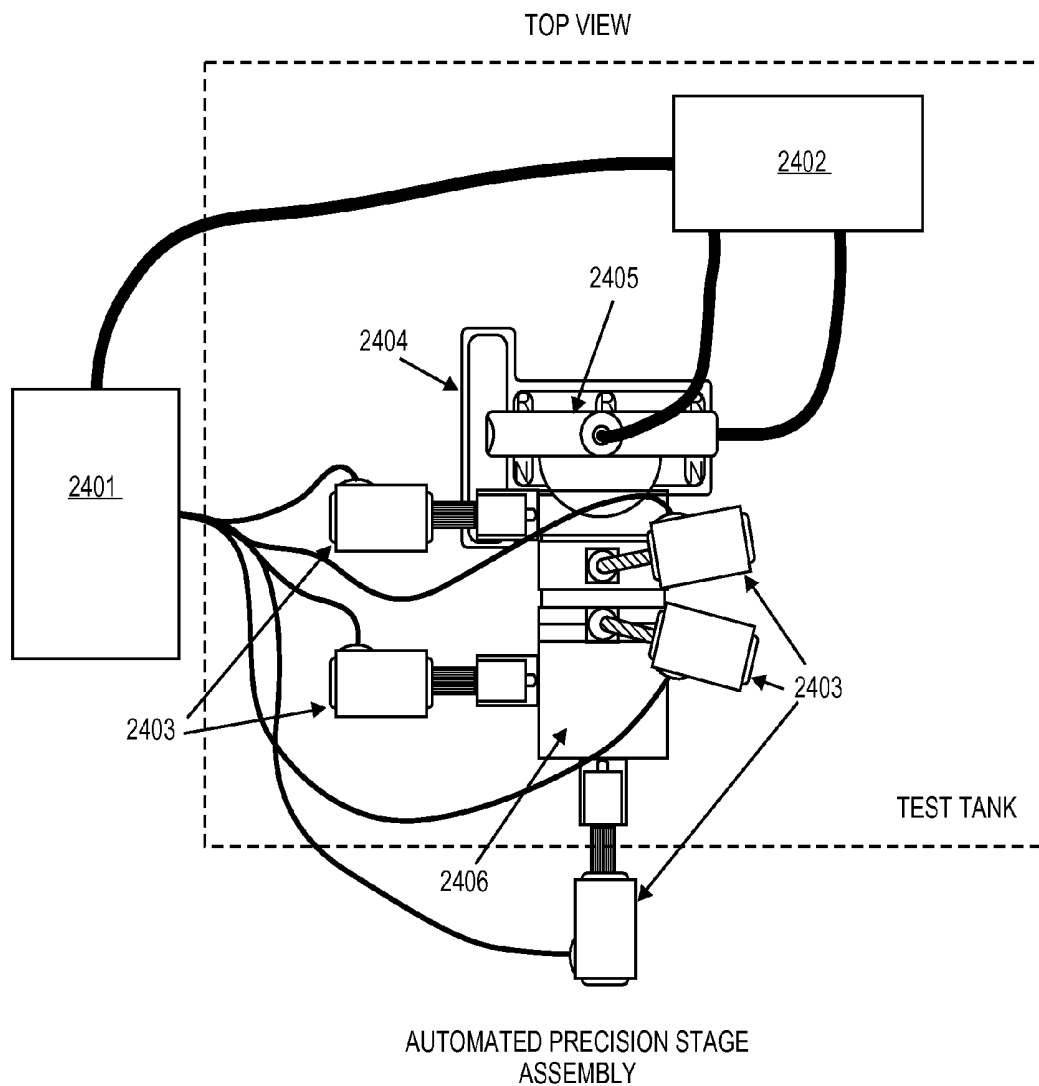
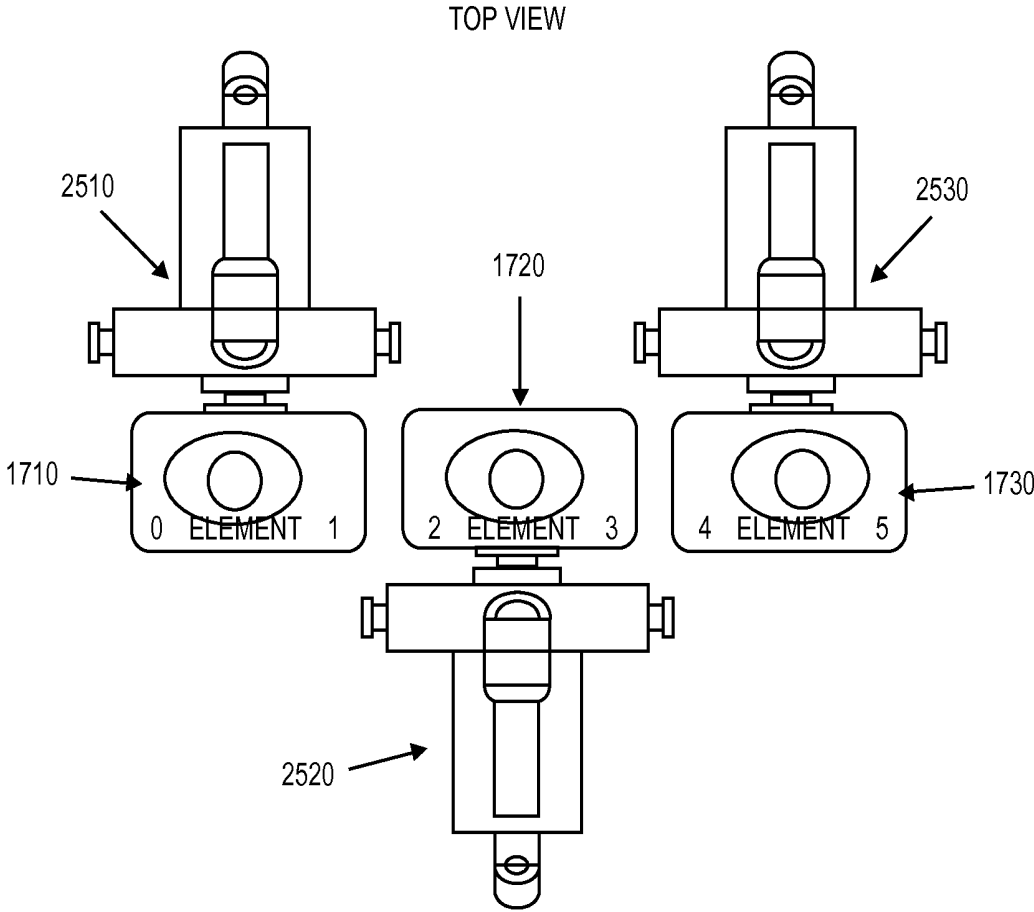

FIG. 24



PRECISION ALIGNMENT STAGE ASSEMBLY

**FIG. 25**

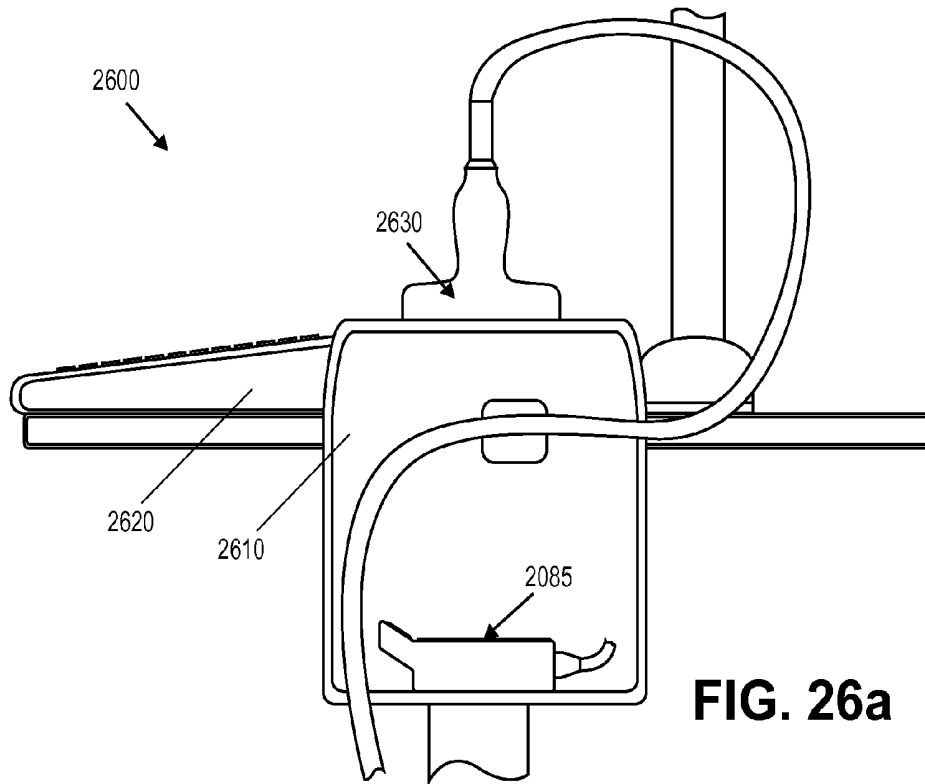

FIG. 26a

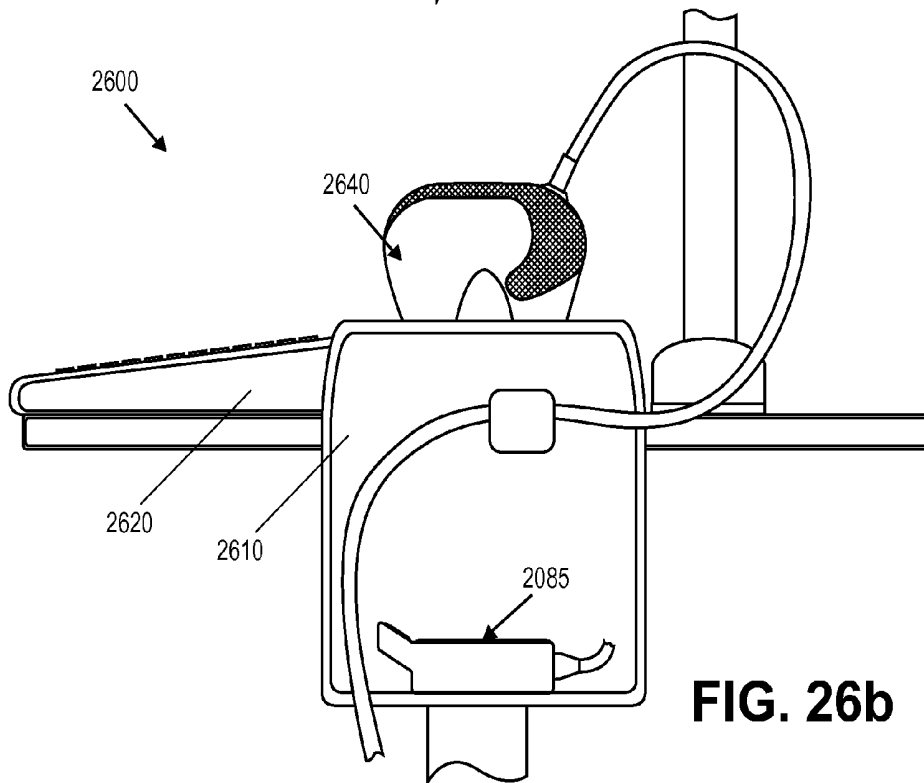

FIG. 26b

## MULTIPLE APERTURE ULTRASOUND ARRAY ALIGNMENT FIXTURE

### CROSS REFERENCE TO RELATED APPLICATIONS

This application is a continuation of U.S. patent application Ser. No. 12/760,327, filed Apr. 14, 2010, now U.S. Pat. No. 8,473,239, which application claims the benefit of U.S. Provisional Patent Application No. 61/169,200, filed Apr. 14, 2009, titled "ALIGNMENT AND FIXTURING OF A UNIVERSAL MULTIPLE APERTURE MEDICAL ULTRASOUND TRANSDUCER", which is herein incorporated by reference.

This application is related to U.S. patent application Ser. No. 11/532,013, filed Sep. 14, 2006, now U.S. Pat. No. 8,105,239, which claims priority to U.S. Provisional Patent Application No. 60/765,887, filed Feb. 6, 2006; and is related to U.S. patent application Ser. No. 11/865,501, filed Oct. 1, 2007, now U.S. Pat. No. 8,007,439, which claims priority to U.S. Provisional Patent Application No. 60/862,951, filed Oct. 25, 2006, and U.S. Provisional Patent Application No. 60/940,261, filed May 25, 2007; and is related to U.S. Provisional Patent Application Nos. 61/169,251, filed Apr. 14, 2009, and 61/169,221, filed Apr. 14, 2009; all of which are herein incorporated by reference.

### INCORPORATION BY REFERENCE

All publications and patent applications mentioned in this specification are herein incorporated by reference to the same extent as if each individual publication or patent application was specifically and individually indicated to be incorporated by reference.

### FIELD OF THE INVENTION

The present invention relates generally to imaging techniques used in medicine, and more particularly to medical ultrasound, and still more particularly to an apparatus for producing ultrasonic images using multiple apertures.

### BACKGROUND OF THE INVENTION

In order to insonify the body tissues, a beam formed either by a phased array or a shaped transducer is scanned over the tissues to be examined. Traditionally, the same transducer or array is used to detect the returning echoes. This design configuration lies at the heart of one of the most significant limitations in the use of ultrasonic imaging for medical purposes; namely, poor lateral resolution. Theoretically, the lateral resolution could be improved by increasing the aperture of the ultrasonic probe, but the practical problems involved with aperture size increase have kept apertures small and lateral resolution poor. Unquestionably, ultrasonic imaging has been very useful even with this limitation, but it could be more effective with better resolution.

In the practice of cardiology, for example, the limitation on single aperture size is dictated by the space between the ribs (the intercostal spaces). For scanners intended for abdominal and other use, the limitation on aperture size is not so obvious, but it is a serious limitation nevertheless. The problem is that it is difficult to know the exact position of the elements of a large apparatus with multiple and separate physical points of contact ("footprints") on the patient. For optimum performance, all of the separated transmit and receive elements should be in the same scan plane. In addition, each element

position must be known to within  $\frac{1}{10}$  wavelength (for example, 0.03 mm at 3 MHz). With conventional ultrasound probes, regardless of array vertical displacement or integration (e.g., 1.5D or 2D), there has never been a need to solve alignment and position issues between multiple arrays or multiple individual elements. The methods and apparatus included here teach how to solve these problems for Universal Multiple Aperture ultrasound probes.

In constructing and maintaining a Universal Multiple Aperture Probe using a combination of two or more individual arrays, attention must be paid to each array's ultrasound beam displacement relative to a central array Z axis. The displacement or rotational axes referred to are X, Y and Z. X varies about the longitudinal array axis, Y varies about the central array axes, also termed twist, and Z varies about the transverse or lateral array axis. A fixture and method for measuring the variation of each array was developed and implemented.

Element position is equally important as displacement from the central array Z axis. The positional relationship of each array element to every other element needs to be established within an individual array and from array to array.

The type of crystal used in each array is irrelevant. That is, any one, one and a half, or two dimensional crystal arrays (1D, 1.5D, 2D, such as a piezoelectric array) and all types of Capacitive Micromachined Ultrasonic Transducers (CMUT) can be utilized in multi-aperture configurations.

### SUMMARY OF THE INVENTION

The present invention relates to a system for measuring and aligning the positions of transducer elements in a multi-aperture ultrasound probe, comprising an alignment assembly configured to hold a plurality of transducer elements, a test block, an ultrasonic sensor configured to receive ultrasonic pulses through the test block from at least one of the plurality of transducer elements, and a controller configured to evaluate data from the ultrasonic sensor and provide transducer calibration data.

In some embodiments, the test block comprises a tank filled with a liquid having a known speed of sound. In other embodiments, the test block comprises a tank filled with a gelatinous material having known speed of sound. In additional embodiments, the test block comprises a solid block having a known speed of sound.

The system can further comprise a signal generator configured to excite at least one of the plurality of transducer elements to transmit ultrasonic pulses. In some embodiments, the signal generator is configured to excite the plurality of transducer elements with a short (wideband) pulse. In other embodiments, the signal generator is configured to excite the plurality of transducer elements with a spread spectrum waveform. In additional embodiments, the signal generator is configured to excite at least one of the plurality of transducer elements with a chirp waveform.

In one embodiment, the alignment assembly comprises an automated alignment assembly configured to automatically align the plurality of transducer elements based on the transducer calibration data from the controller. The alignment assembly can comprise at least one stepper motor and a stepper motor controller, for example. In some embodiments, the stepper motor controller drives the at least one stepper motor to align the transducer element.

In other embodiments, the alignment assembly comprises a manual alignment assembly. The manual alignment assembly can include manual controls configured to manipulate the plurality of transducer elements in the x, y, and z axes.

In some embodiments, the controller runs algorithms configured to detect relative elapsed times to a plurality of receiving transducer elements disposed on the ultrasonic sensor. In other embodiments, the controller runs algorithms configured to compute complete transit times from at least one of the plurality of transducer elements to a plurality of receiving transducer elements disposed on the ultrasonic sensor. In some embodiments, the controller runs algorithms configured to compute the relative position of the plurality of transducer elements based on the transducer calibration data.

In some embodiments, the system further comprises a graphical user interface configured to display the transducer calibration data.

In other embodiments, the alignment assembly is configured to hold a probe containing the plurality of transducer elements.

In some embodiments, the ultrasonic sensor includes a plurality of receiving transducer elements.

In additional embodiments, the controller is configured to digitize and store the received ultrasonic pulses.

A system for measuring and reporting the positions of transducer elements in a multi-aperture ultrasound probe is also provided, comprising a plurality of transducer elements, a calibration assembly configured to hold the plurality of transducer elements, a test block, an ultrasonic sensor configured to receive ultrasonic pulses through the test block from at least one of the plurality of transducer elements, and a controller configured to evaluate data from the ultrasonic sensor and provide transducer calibration data.

In some embodiments, the test block comprises a tank filled with a liquid having a known speed of sound. In other embodiments, the test block comprises a tank filled with a gelatinous material having known speed of sound. In additional embodiments, the test block comprises a solid block having a known speed of sound.

In some embodiments, the calibration assembly is configured to automatically determine the relative positions of the plurality of transducer elements based on the transducer calibration data from the controller.

In one embodiment, the controller runs algorithms configured to detect relative elapsed times to a plurality of receiving transducer elements disposed on the ultrasonic sensor. In other embodiments, the controller runs algorithms configured to compute complete transit times from the relative elapsed times. In additional embodiments, the controller runs algorithms configured to compute the relative position of the plurality of transducer elements based on the transducer calibration data.

In some embodiments, the system further comprises a graphical user interface configured to display the transducer calibration data.

In another embodiment, the system further comprises memory in the multi-aperture ultrasound probe configured to record the transducer calibration data.

A method is also provided for measuring and aligning the positions of transducer elements in a multi-aperture ultrasound probe, comprising mounting a plurality of transducer elements in an alignment assembly, transmitting ultrasonic pulses through a test block from at least one of the plurality of transducer elements, receiving the ultrasonic pulses with an ultrasonic sensor, and evaluating the received ultrasonic pulses from the ultrasonic sensor with a controller to provide transducer calibration data.

In some embodiments, the method further comprises aligning the plurality of transducer elements based on the transducer calibration data.

In other embodiments, the method comprises automatically aligning the plurality of transducer elements based on the transducer calibration data. In other embodiments, the method comprises manually aligning the plurality of transducer elements based on the transducer calibration data.

In some embodiments, the controller runs an algorithm configured to detect relative elapsed times to a plurality of receiving transducer elements disposed on the ultrasonic sensor. In other embodiments, the controller runs an algorithm configured to compute complete transit times from the transducer element to a receiving transducer element disposed on the ultrasonic sensor. In additional embodiments, the controller runs an algorithm configured to compute the relative position of the plurality of transducer elements based on the transducer calibration data.

#### BRIEF DESCRIPTION OF THE DRAWINGS

In the drawings:

FIG. 1 illustrates a two-aperture system.

FIG. 2 illustrates a three-aperture system.

FIG. 3 is a schematic diagram showing a possible fixture for positioning an omni-directional probe relative to the main probe.

FIG. 4 is a schematic diagram showing a non-instrumented linkage for two probes.

FIG. 5 is a block diagram of the transmit and receive functions where a three array Multiple Aperture Ultrasound Transducer and the associated MAUI electronics are used in conjunction with a host ultrasound machine. In this embodiment, the center probe is used for transmit only and mimics the normal operation of the host transmit probe.

FIG. 5a is a block diagram of the transmit and receive functions where a two array Multiple Aperture Ultrasound Transducer and the associated MAUI electronics are used as an add-on to a host ultrasound machine, primarily for cardiac applications, with an add-on instrument. In this case, one probe is used for transmit only and mimics the normal operation of the host transmit probe, while the other probe operates only as a receiver.

FIG. 6 is a block diagram of the transmit and receive functions where a Multiple Aperture Ultrasound Transducer is used in conjunction with only a Multiple Aperture Ultrasonic Imaging (MAUI) device. The stand-alone MAUI electronics control all elements on all apertures. Any element may be used as a transmitter or omni-receiver, or grouped into transmit and receive full apertures or even sub-arrays. In this figure the insonification emanates from the central aperture, aperture 2 of 3 apertures.

FIG. 6a depicts the insonification emanating from other than center aperture, in this figure Aperture 3 of 3.

FIG. 6b is an illustration of two apertures being used a Multiple Aperture Ultrasound Transducer is used in conjunction with only a Multiple Aperture Ultrasonic Imaging (MAUI) device. In this figure the insonification emanates from aperture 2 of 2.

FIG. 6c is an illustration of two apertures being used a Multiple Aperture Ultrasound Transducer is used in conjunction with only a Multiple Aperture Ultrasonic Imaging (MAUI) device. In this figure the insonification emanates from aperture 1 of 2.

FIG. 7a is a top view of the precision array carrier with six adjustment screws and an array installed.

FIG. 7b is a side view showing the longitudinal axis adjustment of an array in the precision array carrier being supported by the array-centering gasket.

FIG. 7c is an end view showing the transverse axis adjustment of the array in the precision array carrier being supported by the array-centering gasket.

FIG. 8a is a top view of the precision array carrier.

FIG. 8b is a side (longitudinal) view of the precision array carrier.

FIG. 8c is an end (lateral) view of the precision array carrier.

FIG. 9a is a top view of the precision array carrier with a centering gasket in place.

FIG. 9b is a side view (longitudinal) of the precision array carrier with a centering gasket in place.

FIG. 9c is an end view (lateral) the precision array carrier with a centering gasket in place.

FIG. 9d is a bottom view of the precision array carrier with a centering gasket in place.

FIG. 10a is a top view of the array in the precision array carrier during a counter-clockwise rotational axis adjustment.

FIG. 10b is a top view of the array in the precision array carrier during a clockwise rotational axis adjustment.

FIG. 11 shows an end view of a precision array carrier 2150 installed on a tissue equivalent phantom 2182 and ready to transmit and receive during alignment.

FIG. 12 shows a side view of the phantom 2182 with the ends of the targets 2167 visible.

FIG. 13a is a top view of a carrier assembly with arrays installed (to become a precision carrier array assembly) and aligned within a precision transducer receptacle and stabilized with an acoustic damping material.

FIG. 13b is a side view of a precision array carrier with arrays installed (to become a precision carrier array assembly) and aligned within a precision transducer receptacle and stabilized with an acoustic damping material.

FIG. 13c is an end view of a precision carrier array with arrays installed (to become a precision carrier array assembly) and aligned within a precision transducer receptacle and stabilized with an acoustic damping material.

FIG. 14a is a top view of a precision carrier array with arrays installed and aligned within a precision transducer head receptacle, the acoustic damping material has set and alignment screws have been removed.

FIG. 14b is a side view of a precision carrier array assembly with arrays installed and aligned within a precision transducer head receptacle, the acoustic damping material has set and alignment screws have been removed.

FIG. 14c is an end view of a precision carrier array with arrays installed and aligned within a precision transducer head receptacle, the acoustic damping material has set and alignment screws have been removed.

FIG. 15 shows a precision transducer receptacle or nose piece and three precision carrier array assemblies seated atop the transducer guides.

FIG. 16 shows the precision transducer receptacle or nose piece and three precision carrier array assemblies as in FIG. 16, and an ultrasound transducer array seated in each transducer guide of the nose piece.

FIG. 17 is a drawing using three independent probes and their installed arrays or transducers. This illustration represents the positional nomenclature and array element numbering conventions.

FIG. 18a shows the Precision Stage Assembly and sections that control movement in three different axes.

FIG. 18b shows the controls for the Precision Stage Assembly.

FIG. 19a depicts is an enclosure containing Right and Left Axial Hydrophones and a Transverse Hydrophone.

FIG. 19b depicts the dual Axial Hydrophones from the side and illustrates the angular orientation of the Transverse Hydrophone.

FIG. 20 is a representation of probes attached to the precision stage assemblies on top of a fluid filled tank, and well above the hydrophone assembly.

FIG. 21a is a graphic of basic geometry used to begin the conversion of distance difference into total distance.

FIG. 21b is a graphic of the detailed geometry used to begin the conversion of distance difference into total distance allowing for the precision location of array element using three hydrophones.

FIG. 22 illustrates a nose piece containing three separate arrays after it is installed into a Multiple Aperture Transducer. This figure includes the transducer specific calibration chip, the transmit synchronization module and probe position displacement sensor.

FIG. 23a is a representation of the graphical user interface or GUI developed to allow for the precise location of elements of multiple arrays under test.

FIG. 23b depicts an array of elements under test with the ultrasound beam in the center of the transverse hydrophone, centered between the left and right hydrophones with the results displayed on the graphical user interface.

FIG. 23c is a representation of an array under test where its beam is on center but with the array to the right of center with the results displayed on the graphical user interface.

FIG. 23d is a representation of an array under test that is physically on the center axis, but has its beam is to the left of center with the results displayed on the graphical user interface.

FIG. 24 is a representation of the automatic precision stage assembly and its major components.

FIG. 25 is a representation using three arrays and three precision alignment stage assemblies showing their physical placement during testing.

FIG. 26a is an illustration of an Onboard Calibration and Quality Assurance fixture mounted to the side of the MAUI standalone system. This illustration depicts a MAUI Radiology probe being evaluated.

FIG. 26b illustrates the Onboard Calibration and Quality Assurance fixture evaluating a MAUI Cardiac probe.

#### DETAILED DESCRIPTION OF THE INVENTION

A Multiple Aperture Ultrasound Imaging (MAUI) Probe or Transducer can vary by medical application. That is, a general radiology probe can contain multiple transducers that maintain separate physical points of contact with the patient's skin, allowing multiple physical apertures. A cardiac probe may contain as few as two transmitters and receivers where the probe fits simultaneously between two or more intercostal spaces. An intracavity version of the probe, will space transmit and receive transducers along the length of the wand, while an intravenous version will allow transducers to be located on the distal length the catheter and separated by mere millimeters. In all cases, operation of multiple aperture ultrasound transducers can be greatly enhanced if they are constructed so that the elements of the arrays are aligned within a particular scan plane.

One aspect of the invention solves the problem of constructing a multiple aperture probe that functionally houses multiple transducers which may not be in alignment relative to each other. The solution involves bringing separated elements or arrays of elements into alignment within a known scan plane. The separation can be a physical separation or simply a separation in concept wherein some of the elements

of the array can be shared for the two (transmitting or receiving) functions. A physical separation, whether incorporated in the construction of the probe's casing, or accommodated via an articulated linkage, is also important for wide apertures to accommodate the curvature of the body or to avoid non-echogenic tissue or structures (such as bone).

Any single omni-directional receive element (such as a single crystal pencil array) can gather information necessary to reproduce a two-dimensional section of the body. In some embodiments, a pulse of ultrasound energy is transmitted along a particular path; the signal received by the omni-directional probe can be recorded into a line of memory. When the process for recording is complete for all of the lines in a sector scan, the memory can be used to reconstruct the image.

In other embodiments, acoustic energy is intentionally transmitted to as wide a two-dimensional slice as possible. Therefore all of the beam formation must be achieved by the software or firmware associated with the receive arrays. There are several advantages to doing this: 1) It is impossible to focus tightly on transmit because the transmit pulse would have to be focused at a particular depth and would be somewhat out of focus at all other depths, and 2) An entire two-dimensional slice can be insonified with a single transmit pulse.

Omni-directional probes can be placed almost anywhere on or in the body: in multiple or intercostal spaces, the suprasternal notch, the substernal window, multiple apertures along the abdomen and other parts of the body, on an intracavity probe or on the end of a catheter.

The construction of the individual transducer elements used in the apparatus is not a limitation of use in multi-aperture systems. Any one, one and a half, or two dimensional crystal arrays (1D, 1.5D, 2D, such as a piezoelectric array) and all types of Capacitive Micromachined Ultrasonic Transducers (CMUT) can be utilized in multi-aperture configurations to improve overall resolution and field of view.

Transducers can be placed either on the image plane, off of it, or any combination. When placed away from the image plane, omni-probe information can be used to narrow the thickness of the sector scanned. Two-dimensional scanned data can best improve image resolution and speckle noise reduction when it is collected from within the same scan plane.

Greatly improved lateral resolution in ultrasound imaging can be achieved by using probes from multiple apertures. The large effective aperture (the total aperture of the several sub apertures) can be made viable by compensation for the variation of speed of sound in the tissue. This can be accomplished in one of several ways to enable the increased aperture to be effective rather than destructive.

The simplest multi-aperture system consists of two apertures, as shown in FIG. 1. One aperture could be used entirely for transmit elements **110** and the other for receive elements **120**. Transmit elements can be interspersed with receive elements, or some elements could be used both for transmit and receive. In this example, the probes have two different lines of sight to the tissue to be imaged **130**. That is, they maintain two separate physical apertures on the surface of the skin **140**. Multiple Aperture Ultrasonic Transducers are not limited to use from the surface of the skin, they can be used anywhere in or on the body to include intracavity and intravenous probes. In transmit/receive probe **110**, the positions of the individual elements  $T_{x,1}$  through  $T_{x,n}$  can be measure in three different axes. This illustration shows the probe perpendicular to the x axis **150**, so each element would have a different position x and the same position y on the y axis **160**. However, the y axis

positions of elements in probe **120** would be different since it is angled down. The z axis **170** comes in or out of the page and is very significant in determine whether an element is in or out of the scan plane.

Referring to FIG. 1, suppose that a Transmit Probe containing ultrasound transmitting elements  $T_1, T_2, \dots T_n$  **110** and a Receive Probe **120** containing ultrasound receive elements  $R_1, R_2, \dots R_m$  are placed on the surface of a body to be examined (such as a human or animal). Both probes can be sensitive to the same plane of scan, and the mechanical position of each element of each probe is known precisely relative to a common reference such as one of the probes. In one embodiment, an ultrasound image can be produced by insonifying the entire region to be imaged (e.g., a plane through the heart, organ, tumor, or other portion of the body) with a transmitting element (e.g., transmit element  $T_{x,1}$ ), and then "walking" down the elements on the Transmit probe (e.g.,  $T_{x,2}, \dots T_{x,n}$ ) and insonifying the region to be imaged with each of the transmit elements. Individually, the images taken from each transmit element may not be sufficient to provide a high resolution image, but the combination of all the images can provide a high resolution image of the region to be imaged. Then, for a scanning point represented by coordinates (i,j) it is a simple matter to calculate the total distance "a" from a particular transmit element  $T_{x,n}$  to an element of tissue at (i,j) **130** plus the distance "b" from that point to a particular receive element. With this information, one could begin rendering a map of scatter positions and amplitudes by tracing the echo amplitude to all of the points for the given locus.

Another multi-aperture system is shown FIG. 2 and consists of transducer elements in three apertures. In one concept, elements in the center aperture **210** can be used for transmit and then elements in the left **220** and right **230** apertures can be used for receive. Another possibility is that elements in all three apertures can be used for both transmit and receive, although the compensation for speed of sound variation would be more complicated under these conditions. Positioning elements or arrays around the tissue to be imaged **240** provides much more data than simply having a single probe **210** over the top of the tissue.

The Multiple Aperture Ultrasonic Imaging methods described herein are dependent on a probe apparatus that allows the position of every element to be known and reports those positions to any new apparatus the probe becomes attached. FIGS. 3 and 4 demonstrate how a single omni-probe **310** or **410** can be attached to a main transducer (phased array or otherwise) so as to collect data, or conversely, to act as a transmitter where the main probe then becomes a receiver. In both of these embodiments the omni-probe is already aligned within the scan plan. Therefore, only the x and y positions **350** need be calculated and transmitted to the processor. It is also possible to construct a probe with the omni-probe out of the scan plane for better transverse focus.

An aspect of the omni-probe apparatus includes returning echoes from a separate relatively non-directional receive transducer **310** and **410** located away from the insonifying probe transmit transducer **320** and **420**, and the non-directional receive transducer can be placed in a different acoustic window from the insonifying probe. The omni-directional probe can be designed to be sensitive to a wide field of view for this purpose.

The echoes detected at the omni-probe may be digitized and stored separately. If the echoes detected at the omni-probe (**310** in FIG. 3 and **410** in FIG. 4) are stored separately for every pulse from the insonifying transducer, it is surprising to note that the entire two-dimensional image can be

formed from the information received by the one omni. Additional copies of the image can be formed by additional omnidirectional probes collecting data from the same set of insonifying pulses.

In FIG. 5, the entire probe, when assembled together, is used as an add-on device. It is connected to both an add-on instrument or MAUI Electronics 580 and to any host ultrasound system 540. The center array 510 can be used for transmit only. The outrigger arrays 520 and 530 can be used for receive only and are illustrated here on top of the skin line 550. Reflected energy off of scatterer 570 can therefore only be received by the outrigger arrays 520 and 530. The angulation of the outboard arrays 520 and 530 are illustrated as angles  $\alpha_1$  560 or  $\alpha_2$  565. These angles can be varied to achieve optimum beamforming for different depths or fields of view.  $\alpha_1$  and  $\alpha_2$  are often the same for outboard arrays, however, there is no requirement to do so. The MAUI Electronics can analyze the angles and accommodate unsymmetrical configurations. FIG. 5a demonstrates the right transducer 510 being used to transmit, and the other transducer 520 is being used to receive.

FIG. 6 is much like FIG. 5, except the Multiple Aperture Ultrasound Imaging System (MAUI Electronics) 640 used with the probe is a stand-alone system with its own onboard transmitter (i.e., no host ultrasound system is used). This system may use any element on any transducer 610, 620, or 630 for transmit or receive. The angulation of the outboard arrays 610 and 630 is illustrated as angle  $\alpha$  660. This angle can be varied to achieve optimum beamforming for different depths or fields of view. The angle is often the same for outboard arrays; however, there is no requirement to do so. The MAUI Electronics will analyze the angle and accommodate unsymmetrical configurations.

In this illustration, transmitted energy is coming from an element or small group of elements in Aperture 2 620 and reflected off of scatterer 670 to all other elements in all the apertures. Therefore, the total width 690 of the received energy is extends from the outermost element of Aperture 1 610 to the outmost element of Aperture 2 630. FIG. 6a shows the right array 610 transmitting, and all three arrays 610, 620 and 630 receiving. FIG. 6b shows elements on the left array 610 transmitting, and elements on the right array 620 receiving. Using one transducer for transmit only has advantages with regard to a lack of distortion due to variation in fat layer. In a standalone system, transmit and/or receive elements can be mixed in both or all three apertures.

FIG. 6b is much like FIG. 5a, except the Multiple Aperture Ultrasound Imaging System (MAUI Electronics) 640 used with the probe is a stand-alone system with its own on-board transmitter. This system may use any element on any array 610 or 620 for transmit or receive as is shown in FIG. 6c. As shown in either FIG. 6b or FIG. 6c, a transmitting array provides angle off from the target that adds to the collective aperture width 690 the same way two receive only transducers would contribute.

Embodiments described herein include a precision carrier for the proper alignment of a universal multiple aperture ultrasound transducer. Referring now to FIGS. 7a-7c, transducer array 2161 can be already "potted" in its own fixture 2161 with lens 2162 intact. Potting procedures are conventional methods to secure the transducer array to its lens and to the case. Flex circuitry, cabling, and attachment to the larger multiple aperture ultrasound transducer fixture can take place after the potting procedure is complete. A benefit of the invention is that it does not require the same transducers to be

utilized during the alignment. Different transducers with different "pots" can be utilized in any location of the alignment fixture thanks to the flexibility of the alignment carrier.

FIGS. 8a-8c provide views of the basic structure and features of embodiments of a precision carrier 2150 for a multiple aperture ultrasound transducer array. FIG. 8a shows a top view of a precision array carrier 2150 with six positioning screws 2151. FIG. 8b shows a side view of a precision array carrier 2150 having two threaded screw holes 2180 on each side. When positioning screws 2151 are inserted into threaded screw holes (e.g., screw holes 2155 and 2156 in FIG. 7b), adjustments may be made to employ longitudinal corrections 2159 to the "seated" array. FIG. 8c shows a side view of a precision carrier 2150 with threaded screw holes 2180 located on each end. When positioning screws are inserted into these threaded screw holes, adjustments may be made to employ lateral corrections 2160 to the "seated" array (as illustrated in FIG. 7c).

FIGS. 9a-9d show a precision array carrier 2150 with an array-centering gasket 2152 installed. FIG. 9a is a top view of the precision carrier 2150, with an array-centering gasket 2152 placed at the bottom of the carrier where the lens 2162 located in the center. FIGS. 9b-9d show side, end, and bottom views of the carrier, respectively. The array centering gasket 2152 on the carrier's L shaped shoulder 2181 as illustrated in FIG. 7b. In FIG. 9b the gasket 2152 extends the entire length of the carrier over the L shaped shoulder 2181. The gasket 2152 extends around the corners of the L shaped shoulder 2181 to cover the ends of the carrier as it illustrated in FIG. 9c. The gasket provides the array translational centering and a pivot point for positioning adjustments during operation without interfering with the integrity of the lens 2162. FIG. 9d provides a view of the lens 2162, the bottom of the precision carrier array centering gasket 2152, and finally the L shaped shoulder 2181.

Referring back to FIGS. 7a-7c, which show top, end, and side views, respectively of a precision array carrier 2150 with an array 2161 inserted therein. The array 2161 is supported end-to-end by positioning screws 2155 and 2156. The array can be supported from each side by positioning screws 2153, 2154, 2157, 2158 and from the bottom by the array centering gasket 2152. FIG. 7b shows the array 2161 in the precision array carrier 2150 being supported by array centering gasket 2152 and ready for longitudinal adjustment. Alternately tightening and loosening positioning screws 2155 and 2156 allows the array 2161 to be adjusted through arc 2159 to correct longitudinal axis errors. FIG. 7c shows the array 2161 in the precision array carrier 2150 supported by the array centering gasket 2152 ready for transverse alignment. Alternately adjusting positioning screw pairs 2157, 2158 and 2153, 2154 allow the array 2161 to be corrected for transverse axis errors.

FIGS. 10a and 10b show a top views of a precision array carrier 2150 with the array 2161 inserted. Arrows depict, respectively, counter-clockwise and clockwise rotational adjusting by way of selective screw adjustments. FIG. 10a shows a tightening of position screws 2153 and 2158 while loosening position screws 2154 and 2157 shifting the array 2161 in a counter-clockwise arc 2165 to correct rotational axis errors. FIG. 10b shows a tightening position of screws 2154 and 2157 while loosening position screws 2153 and 2158 to shift the array 2161 in a clockwise arc 2166 to correct rotational axis errors.

FIG. 11 shows an end view of a precision array carrier 2150 installed on a tissue equivalent phantom or test block 2182 and ready to transmit and receive during alignment. A 'phantom' is a structure filled with tissue equivalent material that has a speed of sound characteristics similar to that of human tissue with known voids and reflectors placed at known loca-

tions within the phantom. This end view of the phantom shows one embodiment including three targets **2167** in profile view. These targets can be echogenic, very reflective, or anechoic, void of reflection. The top target can be at a pre-determined depth *D* from the surface of the phantom and the face of array carrier **2150**. The other targets can be spaced at distances *D1* and *D2* from the top target. In some embodiments, the pre-determined depth *D* can be 100 mm from the top target to the face of the array. The other targets can have *D1* and *D2* distances of 10 mm, for example. However, any range of depths for the targets **2167** can be used, depending on the desired application of the transducer arrays. The perpendicular targets **2167** serve to assist during the longitudinal adjustment of the array positioning. When correctly positioned, the three targets would be displayed as exactly perpendicular to the front of the array, and further, each target **2167** would be displayed equidistantly one a top the other.

FIG. **12** shows a side view of the phantom **2182** with the ends of the targets **2167** visible. Once transmitting and receiving, a lateral adjustment could be made to the array **2163** in the carrier **2150**. The correct alignment is for achieved when all targets are visible above and below the center target **2168**.

FIGS. **13a-13c** show a precision array carrier **2150** with an array **2161** inserted and aligned, in top, side, and end views, respectively. At this stage an acoustic damping material **2162** can be poured into the gap between the array and the carrier to stabilize the position of arrays **2161**. FIG. **13b** is a side view of the precision array carrier **2150** showing the gap between the array **2161** and the precision array carrier **2150** filled with acoustic damping material **2162**. FIG. **13c** shows the gap between the array **2161** and the precision array carrier **2150** filled with acoustic damping material **2162**.

FIGS. **14a-14c** show the precision array carrier **2150** with the array **2161** inserted and aligned in top, side, and end views, respectively. The acoustic damping material **2162** has cured and the six alignment screws have been removed. FIG. **14b** is a side view of the precision array carrier **2150** with the array **2161** inserted, aligned, the acoustic damping material **2162** cured and the position alignment screws removed: At this point, the precision array carrier **2150** with its captured array becomes a precision carrier array assembly **2163**.

FIG. **15** shows a multi-aperture ultrasound probe assembly **2183** constructed with precision transducer receptacles surrounded by structural supports **2164**. The structural supports **2164** can be constructed out of many hard materials (e.g., metals or plastics) and usually are built into a larger structure such as the probe **2200** in FIG. **22**. In FIG. **15**, the three precision carrier array assemblies **2163** are inserted into the precision transducer receptacles **2166**.

FIG. **16** shows the multi-aperture probe assembly **2183** having precision transducer receptacles **2166** with the precision array assemblies **2163** each locked into the receptacles, thus completing the construction of the multi-aperture ultrasound probe **2184** having three transducer arrays.

FIG. **22** shows a completed probe **2200** with arrays **1701**, **1702**, and **1703** fitted in array receptacles and ready for submission to the calibration cycle.

Alternative apparatus and methods for constructing and aligning multi-aperture ultrasound probes will now be discussed. As described above, variations in the ultrasound beam displacement or rotation of both the insonifying and receiving probes about the *x*, *y* and *z* axes must be detected and corrected. A MAUI alignment fixture for aligning a multi-aperture probe uses one or more precision angular alignment controls, precision stage assemblies that provide for the adjustment, in 6 degrees of freedom of the each array under test.

One of the great practical difficulties in making multi-aperture imaging systems, as outlined above, is the requirement to precisely align the elements of the multiple arrays. It is well recognized that by increasing the effective aperture of a probe system by including more than one probe head and using the elements of all of the probes to render an image, the lateral resolution of the image can be greatly improved. In order to render an image, the relative positions of all of the elements must be known precisely. Optionally, if the probe system has position and rotation adjustments, a display is provided to position all of the elements to be in the same plane of scan and to transmit or receive in the same plane of scan.

FIG. **17** shows a probe system **1700** comprising three probes **1701**, **1702**, and **1703** working together as a multi-aperture transducer though not assembled in a single shell. This is not a standard embodiment of a multiple aperture transducer, but serves here to aid in describing arrays alignment. A multi-aperture transducer can comprise of any number of arrays **1710**, **1720**, **1730** (two or more), or even individual elements. For practical reasons, arrays in probes can easily be manufactured with a large number of elements and element spacing within a head can be well controlled. If one can precisely position the end elements of each probe, it is possible to imply the positions of the other elements. Therefore, a fixture will be described which finds the positions of the elements. This apparatus could determine the exact location of independent elements either inside or outside of an array; however, because arrays are typically constructed in a linear format, the embodiment discussed here only identifies the end elements.

In FIG. **17** these end elements are designated as element numbers 0 through 5, where 0 and 1 are the end elements of array **1710**, 2 and 3 are the end elements of arrays **1720** and **4** and 5 are the end elements of array **1730**. Any of the intermediate elements could be located in the same way as will be described.

A precision alignment stage assembly is shown in FIG. **18a**. The far left area of the assembly **1801** allows for the mechanical connection of a single probe, such as **1701** from FIG. **17**. The precision alignment stage assembly has three separate mechanisms **1801**, **1802** and **1803** that control the position of the attached array in *x*, *y* and *z* axes. Several alignment stage assemblies can be used in concert so that multiple probe arrays can be manipulated independently. FIG. **18b** allows the operator to manipulate an array in any axis by using controls **1805**, **1806**, **1807**, **1808**, and bearing **1809**. Precision screws **1804**, **1805**, **1806**, **1807**, and **1808** can be adjusted, and bearing **1809** can be rotated to affect one or more axes for the array during the alignment process.

FIG. **25** shows the arrays **1710**, **1720** and **1730** attached in line to precision alignment stages **2510**, **2520** and **2530**. With the arrays set in place, they can now transmit to common points of interest and compare their points of impact with the other arrays.

FIG. **20** illustrates probes **1701**, **1702** and **1703** from FIG. **17** now attached to alignment stage assemblies above a tank or test block **2012**. The tank can be filled with any liquid, fluid, gel, solid, or other medium **2014** that is desirable for manufacture and safety considerations, as long as the speed of sound for the fluid is known. The tank can include a mounting location for the alignment stage assemblies. In some embodiments, as shown in FIG. **20**, multiple alignment stage assemblies holding transducer elements can be mounted on the test block. From this position, it is possible to transmit ultrasonic pulses from the elements of any of the arrays to be received by ultrasonic sensor or hydrophones **2085** at the other end of the tank **2012**.

Referring now to FIGS. 19a-19b, a multi-axis ultrasonic sensor or hydrophone 2085 may be used to detect the X, Y and Z positions of each element of a single array or multiple arrays under test. The multi-axis hydrophone 2085 can include a transverse hydrophone 2086, and right and left hydrophones 2087 and 2088. The common targets for the probes 1701, 1702 and 1703 to shoot at are elements 2091, 2092 and 2093 on the right hydrophone 2087. On the left hydrophone 2088, elements 2094, 2095, and 2096 are the targets.

The basic technique for aligning and calibrating a multiple aperture probe can now be addressed referring to FIGS. 19a, 19b and 20. The probe can be attached to a signal generator configured to excite any of the transducer elements to transmit ultrasonic pulses. An ultrasonic signal is transmitted which exhibits good autocorrelation properties (e.g., a long frequency sweep, or 'chirp' waveform, a short (wideband) pulse, a spread spectrum waveform, etc.) from at least one element in arrays 1710, 1720 and 1730. The transmitted ultrasonic signal can travel through the test block and be received by the receiving hydrophone transducer elements 2091, 2092, 2093, 2094, 2095, 2096 and the transverse hydrophone 2086. It is important to note that detection of the ultrasonic signal or pulse as received by the hydrophone arrays cannot be detected accurately enough by cross correlation with the signal impressed on the probe element because the probe element itself distorts the signal.

Two innovative techniques are used to obtain the needed accuracy in finding the relative time delays and hence the relative distances. The first technique is to use cross correlation between the signal received at one element of the hydrophone (for example 2091) and the signal received at another element of the same hydrophone (for example 2093). The correlation peak will yield the time difference and thus the distance difference.

The second technique is to interpolate between samples of the received waveforms to obtain better time resolution than simply the sampling interval. Perhaps the best way to accomplish both of these tasks is to take the Fourier transform of both signals, fill in zeros for the high frequency components of a much larger transform. Call these larger transforms FFT1 and FFT2. Then find the peak of the inverse transform of (FFT1\*(conjugate of FFT2)).

A third technique is necessary to convert differential distances to total distance. Consider the triangle bce in FIG. 21a where the point b represents one of the elements for which we need to compute a position, and c and e are known reference points in the bottom of the water tank. It is desired to measure the lengths  $d_4$  and  $d_0$  by triangulation, but just knowing the difference between  $d_0$  and  $d_4$  is not enough. By adding a transverse hydrophone (see 2086 in FIG. 19a) in the bottom of the tank we have two triangles from which we can compute  $d_0$  and  $d_4$ . Let e, d, and c be the locations of the hydrophones 2094, 2095 and 2096 or 2091, 2092 and 2093 of FIG. 19a.

For the following analysis, the hydrophones 2094, 2095 and 2096 must be on the same line and on a parallel line to that formed by 2091, 2092 and 2093. The distance between 2094 and 2095 is designated  $d_1$ , and the distance between 2095 and 2096 is designated  $d_3$ .  $d_1$  and  $d_3$  must be known precisely as this becomes the reference "yardstick" for the other measurements. 2095 should be roughly centered between 2094 and 2096LN, but  $d_1$  does not need to equal  $d_3$ . The same requirements apply to R0, RC, and RN.

Let  $d_2$  be the reference distance and define measured distances as:

$$d_{2m} = d_2 - d_2 = 0$$

$$d_{0m} = d_0 - d_2$$

$$d_{4m} = d_4 - d_2$$

From the law of cosines we have

$$d_4^2 = d_2^2 + d_3^2 - 2d_3d_2 \cos \alpha$$

$$d_0^2 = d_2^2 + d_1^2 - 2d_1d_2 \cos(\pi - \alpha) = d_2^2 + d_1^2 + 2d_1d_2 \cos \alpha$$

$$\cos \alpha = (d_4^2 - d_2^2 - d_3^2) / (-2d_3d_2) = (d_0^2 - d_2^2 - d_1^2) / (2d_1d_2)$$

$$d_4^2 - d_2^2 - d_3^2 = -(d_0^2 - d_2^2 - d_1^2)d_3/d_1$$

$$(d_{4m} + d_2)^2 - d_2^2 - d_3^2 + (d_{0m} + d_2)^2 d_3/d_1 - d_2^2 d_3/d_1 - d_1 d_3 = 0$$

Combining and cancelling terms this becomes

$$d_2 = (-d_{4m}^2 + d_3^2 - d_{0m}^2 d_3/d_1 + d_1 d_3) / (2d_{4m} + 2d_{0m} d_3/d_1)$$

Then  $d_0 = d_{0m} + d_2$  and  $d_4 = d_{4m} + d_2$

Thus we have the full measurements from received differential times.

Two parallel "yardsticks" or right and left hydrophones are provided in the bottom of the tank in order to measure position along the z axis from FIG. 1, and as is illustrated in FIG. 23b. It will be the goal to position all of the probe elements from all three arrays 1701, 1702 and 1703 in a line midway between the two yardsticks using the various controls illustrated in FIG. 18b.

Referring now to FIG. 21b, consider the measurement of the position of any probe element such as M0 1206. First, consider using the right yardstick R0-RC-RN 2091, 2092, 2093. By transmitting a chirp signal from element M0 1206 and receiving it on hydrophones at R0, RC, and RN 2091, 2092 and 2093, one can calculate the differential times for transmission along the paths  $d_0$ ,  $d_2$ , and  $d_4$ . Times can be converted to distances if the speed of ultrasound of the test block medium is known. If the test block medium is water, the speed of sound is approximately  $1.40238742 + 5.03821344 * TE / 1000 - 5.80539349 * TE^2 / 100000 + 3.32000870 * TE^3 / 10000000 - 1.44537900 * TE^4 / 1000000000 + 2.99402365 * TE^5 / 100000000000$ . (mm per microsecond) where TE is the temperature in degrees Celsius. Differential distances can be converted to total distances according to the derivation above.

Now from trigonometry, distance  $a = ((d_0^2 - d_4^2 + (d_1 + d_3)^2) / (2(d_1 + d_3)))$

The position along the x' axis is  $d_1 - a$ .

Assuming that the element is midway between the two yardsticks, then

the position along the y' axis is  $\sqrt{(d_0^2 - a^2 - (zr/2)^2)}$ .

Initially considerable error may occur as a result of this assumption, but the measurement of z will allow for adjustment of the element or the entire probe assembly until this assumption is satisfied.

Again referring to FIG. 21b, the same computations for x' and y' can be made using the left yardstick 2094, 2095 and 2096; and, the results can be averaged for increased accuracy. But the main reason for having two yardsticks is the ability to measure the z axis; the elements position in or out of the scan plane as illustrated in FIG. 1. Then the array alignment apparatus can display it (see FIG. 23a, 2300), and thus allow either manual (FIG. 18b) or automatic (FIG. 24) correction and alignment. The z variable is proportional to the time of arrival difference of the pulse as received at RC 2092 and LC 2095. The probe position should be adjusted until the time difference is close to zero. When this is done, all of the x and y measurements will be accurate and the relative positions of all of the elements will be known.

Finally a controller (such as a computer) can scan and find the maximum signal strength on the transverse hydrophone **2086** and record the angular displacement for the probe element.

To use the multiple aperture array alignment apparatus as a daily calibrator, multiple aperture ultrasound transducers will already be fully assembled, such as the embodiment illustrated in FIG. **22**. Therefore, all of these measurements will have to be referenced to axes on the probe assembly. In the multi-aperture transducer probe assembly **2200** shown in FIG. **22**, it would be reasonable to rotate and translate all measurements to a new coordinate system (x,y) centered on the center array. The appropriate coordinate system would be dependent on the ultrasound imaging system for which the probe assembly would be used. The multi-aperture probe can have a resident calibration memory or cal chip **2201** that can be programmed with calibration data received from the automated precision stage assembly, described below.

The transmit synchronization module **2202** is not related to calibration, but is necessary to identify the start of pulse when the probe is used as an add-on device with a host machine transmitting. The probe displacement sensor **2203** can be an accelerometer or gyroscope that senses the three-dimensional movement of the probe. During calibration, the probe must be securely attached to the array alignment apparatus so that the probe is still.

Referring now to FIG. **23a**, a proprietary graphical user interface or GUI **2300**, allows the elemental array data to be visualized in real-time allowing for correction of the x, y and z variation errors. The two wide vertical lines **2001** and **2003** represent the z positions of the yardsticks R0-RC-RN (**2091**, **2092**, and **2093** from FIG. **19a**) and L0-LC-LN (**2094**, **2095**, and **2096** from FIG. **19a**). The thinner vertical line **2302** is the z=0 line and the desired position of each of the elements of a probe system. The vertical position is the x coordinate.

Each small square, such as **2305**, **2306**, **2307**, **2308**, **2309**, **2310** and **2011**, is the position of a probe element in the x-z plane. In this example there are six small squares indicating the positions of the end elements of three probe heads. However, the positions of more or fewer elements could be displayed in this way. The thin horizontal lines **2312**, **2313**, **2314**, **2315**, **2316**, **2317** and **2018** represent the directivity and angular spread of each element as detected on the multi-axis hydrophone. A useful angular spread measure is the number of hydrophone elements on the transverse hydrophone array which record signal strength greater or equal to half of the maximum strength.

FIG. **23b** depicts a probe element positioned correctly with the z position **2305** at or near z=0 and its directivity positioned over the centerline. In contrast, FIG. **23c** depicts a probe element with its z position **2305** offset toward the right hydrophone. The resulting display shows the small square, **2305**, to the right of centerline, **2302**. Note that in this case, the element position is in error, but the element directivity remains over the centerline as indicated on the display by the horizontal line **2312** remaining centered over centerline, **2302**.

Finally, FIG. **23d** depicts a probe element correctly positioned with its z **2305** position at or near z=0, **2302**. The directivity **2312**, however, is misaligned in this case with an offset toward the left hydrophone as indicated by the horizontal line shifted to the left of centerline, **2302**. In this case, the directivity needs to be corrected by adjusting the angulation to bring the directivity back over center. This could be accomplished, for example, by using controls **1805** and **1807** in FIG. **18b**. Thus with this display, element position and directivity can be monitored simultaneously and both brought into alignment.

Adjustments of the probe position and angulation with the precision alignment stage assembly or assemblies should continue until all of the small squares and all of the horizontal lines are aligned on the center vertical line as closely as practicable, ensuring in alignment in the z axis. As this is done, the x and y positions will be computed accurately and no separate iteration will be required for these.

In some manufacturing formats, arrays **2406** could be loaded into an automated precision stage assembly like the one in FIG. **24**. Here, arrays while still within their nose pieces can still be manipulated. In FIG. **24**, we see an automated precision stage assembly, **2406**, fitted with precision stepper motors, **2403**. Stepper motor controller, **2401**, drives the transducer, **2405**, under test in response to instructions from controller, **2402**. The controller, **2401**, evaluates data from the hydrophone assembly, **2404**, and calculates transducer corrections. Test programs residing in the controller, **2402**, provide transducer specific calibration data back to the transducer, **2405**, under test incorporation in its on board calibration chip, **2201**. This automatically acquired element and array position data would be MAUI probe specific and would be used to optimize probe and system performance.

Using the precision stage assemblies with the array alignment system is only part of the value of the system. FIGS. **26a** and **26b** illustrate array alignment systems **2610** attached to the control unit **2620** of an ultrasound machine **2600**. A cut away shows hydrophone assembly **2085** is located at the bottom of the fluid filled system **2610**. In FIG. **26a** a MAUI general radiology probe **2630** is affixed to the system for testing. In FIG. **26b**, a MAUI cardiac probe **2640** is affixed to the system for calibration. The portability of this system, therefore allows for calibration of probes in the field multiple times per day. Additionally the MAUI system would alert the operator if service or maintenance was required.

To calibrate a probe, MAUI electronic apparatus can send a test pattern to the arrays in the probe to transmit to the hydrophone assembly **2085**. When the positions of the probes and their directivities are reported as a result of the sequence, the positions of all of the elements can be downloaded to a file specific to that probe. Each file is stored in the probe calibration chip **2201**. The calibration chip reports element positions in x, y and z axes to every MAUI electronic apparatus it connects to, and therefore can perform multiple aperture imaging without recalibrating before use with a different MAUI apparatus. The calibration chip memory can also be used to analyze probe performance and reliability.

In the special case in which all of the transmit and receive elements are aligned in the same plane or are manufactured so that there is no adjustment in z position, a simplified alignment fixture can be used. Instead of two parallel "yardsticks" of hydrophones, a single yardstick can be used. In this case the probe would be centered over the single yardstick using a plumb bob or a clamping device. The x and y measurements would then be made assuming z=0 and zr=0. This is possible since accuracy in the value of z is much less critical in beam-forming than is accuracy in the values of x and y. Thus adjusting z by the relatively crude methods of sighting with a plumb bob or clamping to a machined edge of the probe can be acceptable in spite of the high accuracy demands for measurement of x and y. Obviously, the cost of this simplified fixture would be much reduced resulting in a fixture which could be used in the field rather just in the probe assembly factory.

As for additional details pertinent to the present invention, materials and manufacturing techniques may be employed as within the level of those with skill in the relevant art. The same may hold true with respect to method-based aspects of the

invention in terms of additional acts commonly or logically employed. Also, it is contemplated that any optional feature of the inventive variations described may be set forth and claimed independently, or in combination with any one or more of the features described herein. Likewise, reference to a singular item, includes the possibility that there are plural of the same items present. More specifically, as used herein and in the appended claims, the singular forms “a,” “and,” “said,” and “the” include plural referents unless the context clearly dictates otherwise. It is further noted that the claims may be drafted to exclude any optional element. As such, this statement is intended to serve as antecedent basis for use of such exclusive terminology as “solely,” “only” and the like in connection with the recitation of claim elements, or use of a “negative” limitation. Unless defined otherwise herein, all technical and scientific terms used herein have the same meaning as commonly understood by one of ordinary skill in the art to which this invention belongs. The breadth of the present invention is not to be limited by the subject specification, but rather only by the plain meaning of the claim terms employed.

What is claimed is:

1. A method of aligning and assembling an ultrasound probe, the method comprising:

placing a first transducer array within a first array carrier secured adjacent to a test block containing an ultrasound transmission medium;

transmitting an ultrasound signal from the first transducer array into the ultrasound transmission medium;

receiving the ultrasound signal with an ultrasonic sensor;

determining a corrected alignment of the first transducer array based on the received signal;

adjusting a position and/or an angulation of the first transducer array relative to the first array carrier with adjustment features of the first array carrier based on the corrected alignment;

after adjusting the position and/or angulation of the first transducer array relative to the first array carrier, stabilizing the first transducer array in the first array carrier by inserting an acoustic damping material into a space between the first transducer array and the first array carrier, and curing the acoustic damping material.

2. The method of claim 1, further comprising, repeating the transmitting, receiving and adjusting steps at least once prior to the step of inserting the acoustic damping material.

3. The method of claim 1, further comprising inserting the first array carrier into a first transducer receptacle within a multiple aperture probe assembly.

4. The method of claim 1, further comprising:

placing a second transducer array within a second array carrier;

transmitting a second ultrasound signal from the second transducer array;

receiving the second ultrasound signal with the ultrasonic sensor;

determining a corrected alignment of the second transducer array based on the received signal;

adjusting a position and/or an angulation of the second transducer array with adjustment features of the second array carrier to match the corrected alignment;

after adjusting the position and/or angulation of the second transducer array relative to the second array carrier, stabilizing the second transducer array in the second array carrier by inserting a second acoustic damping material into a space between the second transducer array and the second array carrier, and curing the second acoustic damping material; and

locking the first array carrier with the first array stabilized therein and the second array carrier with the second transducer array stabilized therein into respective precision transducer receptacles in a probe structural support member.

5. The method of claim 1, wherein the transmitting step comprises transmitting a test pattern signal from transducer elements of the transducer array into the test block.

6. The method of claim 5, wherein the receiving step further comprises receiving the test pattern signal with the ultrasonic sensor positioned at an opposite side of the test block from the transducer array, and wherein the determining step further comprises determining the corrected alignment of the transducer array by evaluating the received test pattern signal with a controller.

7. The method of claim 5, wherein the determining step further comprises comparing relative elapsed times between transmitting the test pattern signal and receiving the test pattern signal.

8. The method of claim 5, wherein the test block comprises a tank filled with a medium having a known speed of sound.

9. The method of claim 5, wherein the test block comprises a plurality of reflectors at fixed known locations within a medium having a known speed of sound.

10. The method of claim 9, wherein the transmitting and receiving steps are performed using the transducer array.

11. The method of claim 10, wherein determining a corrected alignment is based on displayed positions of the reflectors.

12. The method of claim 1, wherein the adjusting step further comprises automatically adjusting the position and/or angulation of the transducer array with adjustment features of the first array carrier.

13. The method of claim 1, wherein the adjusting step further comprises adjusting with a stepper motor the position and/or angulation of the transducer array with adjustment features of the first array carrier.

14. The method of claim 1, wherein the adjusting step further comprises turning a set screw in the first array carrier to adjust the position and/or angulation of the transducer array within the first array carrier.

\* \* \* \* \*

专利名称(译)	多孔超声阵列对准夹具		
公开(公告)号	<a href="#">US9192355</a>	公开(公告)日	2015-11-24
申请号	US13/894192	申请日	2013-05-14
[标]申请(专利权)人(译)	SPECHT DONALD F BREWER KENNETH D 史密斯戴维M ADAM SHARON 大号 伦斯福德JOHN P		
申请(专利权)人(译)	SPECHT唐纳德F. 布鲁尔, KENNETH D. 斯密, 大卫M. ADAM, SHARON L. 伦斯福德, 约翰P.		
当前申请(专利权)人(译)	MAUI IMAGING, INC.		
[标]发明人	SMITH DAVID M ADAM SHARON L SPECHT DONALD F BREWER KENNETH D LUNSFORD JOHN P		
发明人	SMITH, DAVID M. ADAM, SHARON L. SPECHT, DONALD F. BREWER, KENNETH D. LUNSFORD, JOHN P.		
IPC分类号	A61B8/00 G01S15/89 G01S7/52 A61B8/08		
CPC分类号	A61B8/42 A61B8/00 A61B8/4218 A61B8/587 G01S7/5205 G01S15/8913 A61B8/0883 Y10T29/49778		
优先权	61/169200 2009-04-14 US		
其他公开文献	US20130247350A1		
外部链接	<a href="#">Espacenet</a> <a href="#">USPTO</a>		

摘要(译)

通过包括多于一个探头并使用所有探头的元件来渲染图像来增加超声成像探头的有效孔径可以极大地改善所生成图像的横向分辨率。为了渲染图像，必须精确地知道所有元素的相对位置。描述了一种校准夹具，其中待校准的探针组件放置在测试块上方，并通过测试块将超声脉冲发送到超声波传感器。当超声脉冲通过待测探头中的一些或所有元件传输时，精确测量波形到达的差分传输时间。根据这些测量，可以计算探针元件的相对位置，并且可以对准探针。

