



(19) **United States**

(12) **Patent Application Publication**
Hwang et al.

(10) **Pub. No.: US 2001/0020129 A1**
(43) **Pub. Date: Sep. 6, 2001**

(54) **ULTRASOUND IMAGING SYSTEM FOR PERFORMING RECEIVING FOCUSING AT POINTS CORRESPONDING TO DISPLAY PIXELS AND METHOD THEREOF**

(30) **Foreign Application Priority Data**

Feb. 16, 2000 (KR)..... 2000-7236

Publication Classification

(75) **Inventors: Jae Sub Hwang, Seoul (KR); Tai Kyong Song, Seoul (KR)**

(51) **Int. Cl.⁷ A61B 8/00**
(52) **U.S. Cl. 600/443; 600/447**

(57) **ABSTRACT**

All RF data received by transducers in response to an ultrasonic signal that was transmit-focused on a point along a predetermined scan lines are stored to compute display data for those points of an object that are not necessarily correspond to the pixels of the screen of a display device. For the determination of display data for each pixel point, reflected ultrasonic signals from multiple points around the point of interest are found and used to detect the peak of a waveform constituted by the reflected ultrasonic signals. With this scheme, the distortion due to conventional interpolation used for a limited number of scan lines can be greatly reduced.

Correspondence Address:
David B. Ritchie
Thelen Reid & Priest LLP
P.O. Box 640640
San Jose, CA 95164-0640 (US)

(73) **Assignee: Medison Co., Ltd.**

(21) **Appl. No.: 09/785,968**

(22) **Filed: Feb. 16, 2001**

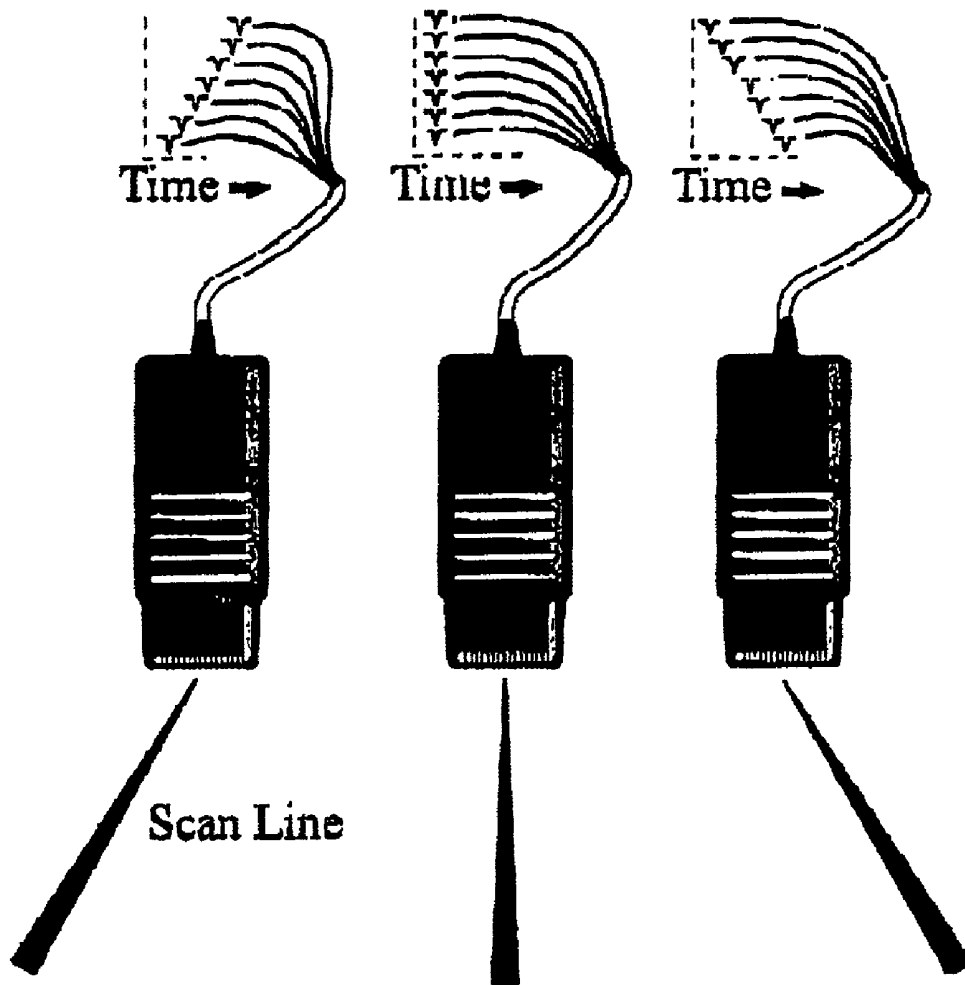

Fig. 1

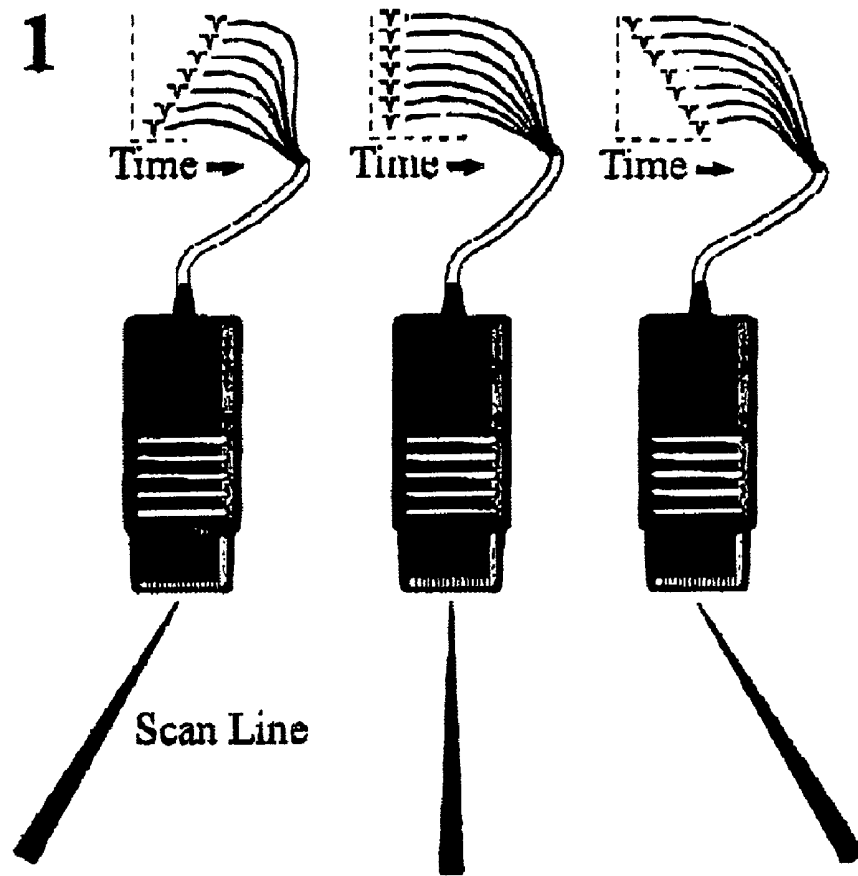

Fig. 2

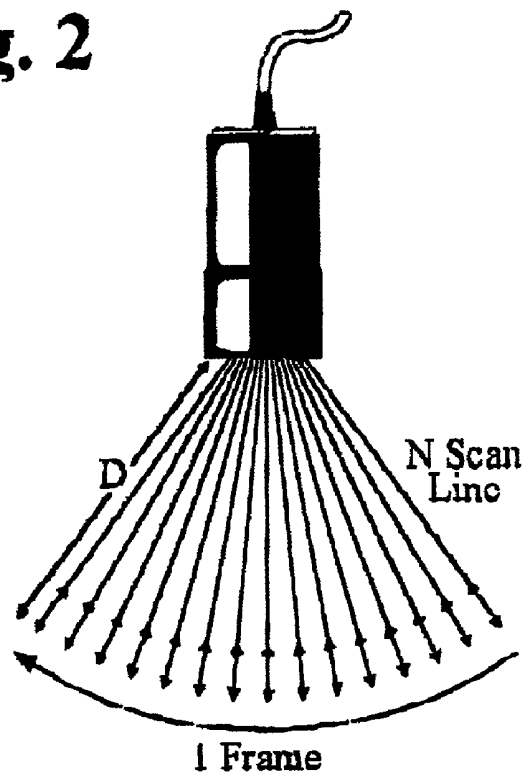

Fig. 3

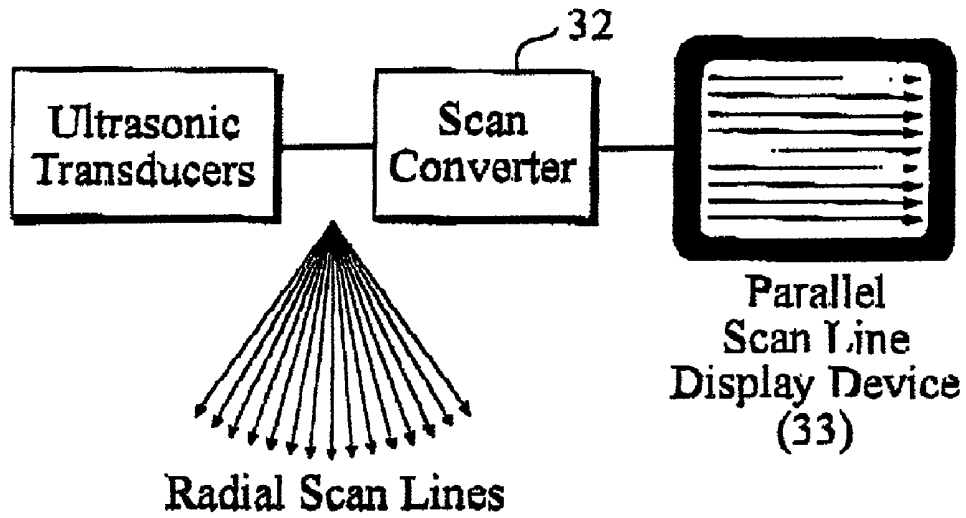

Fig. 4

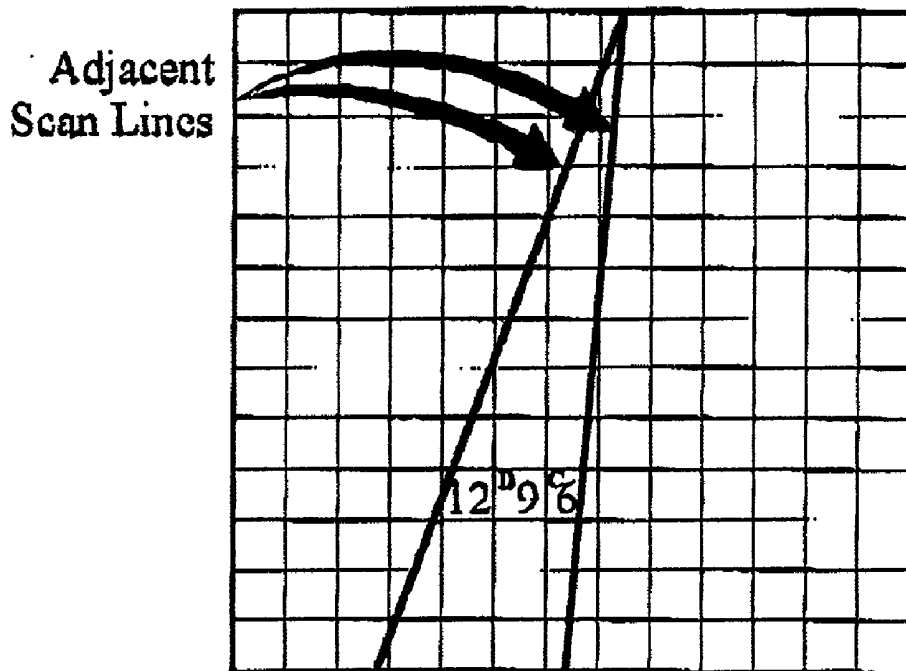

Fig. 5

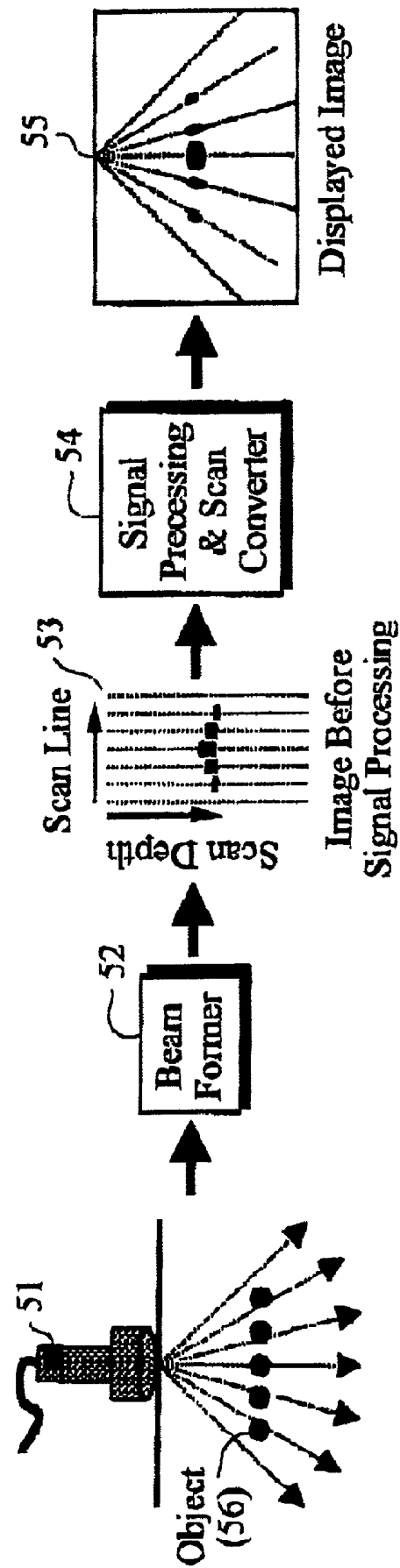

Fig. 6

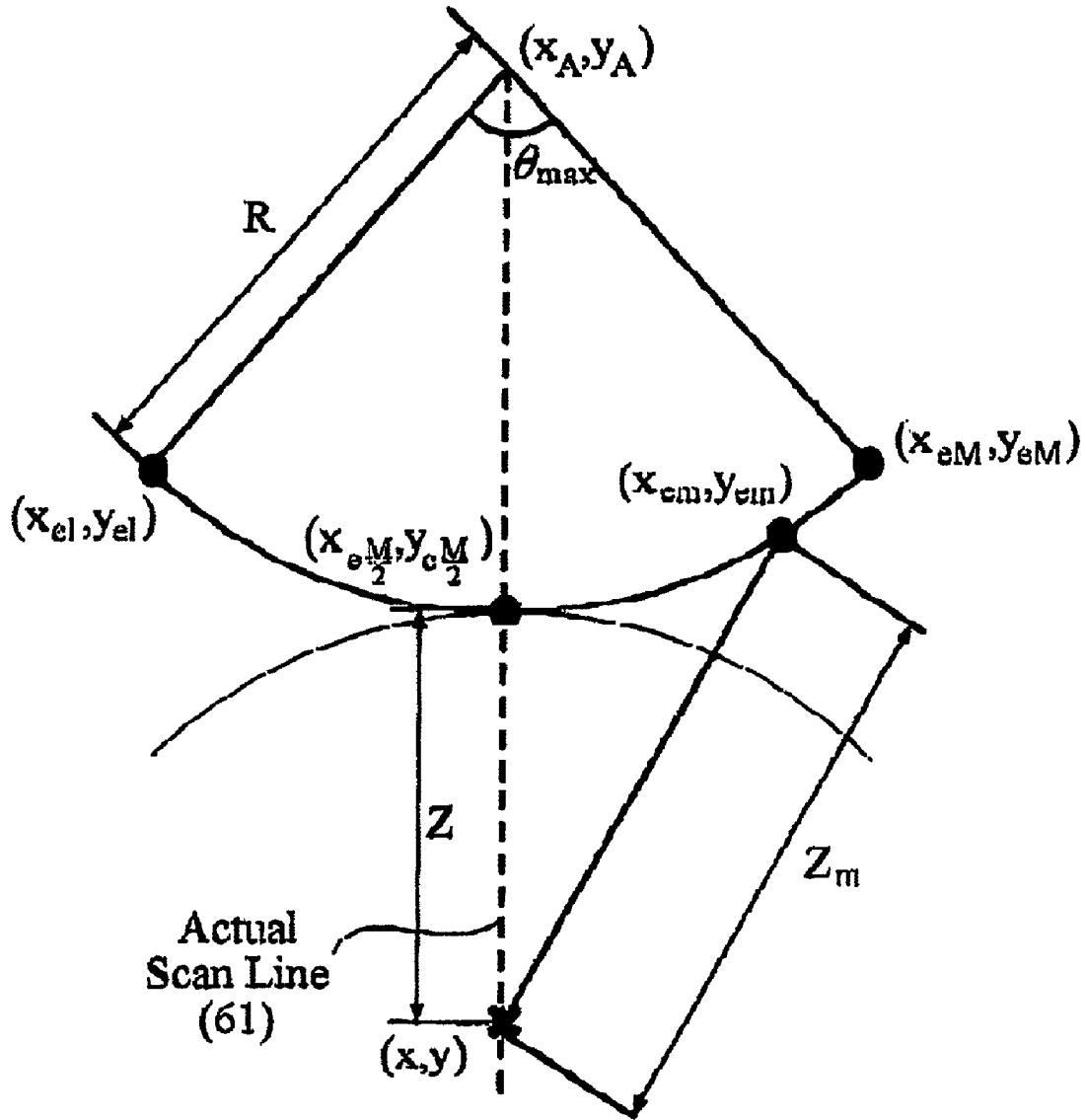

Fig. 7

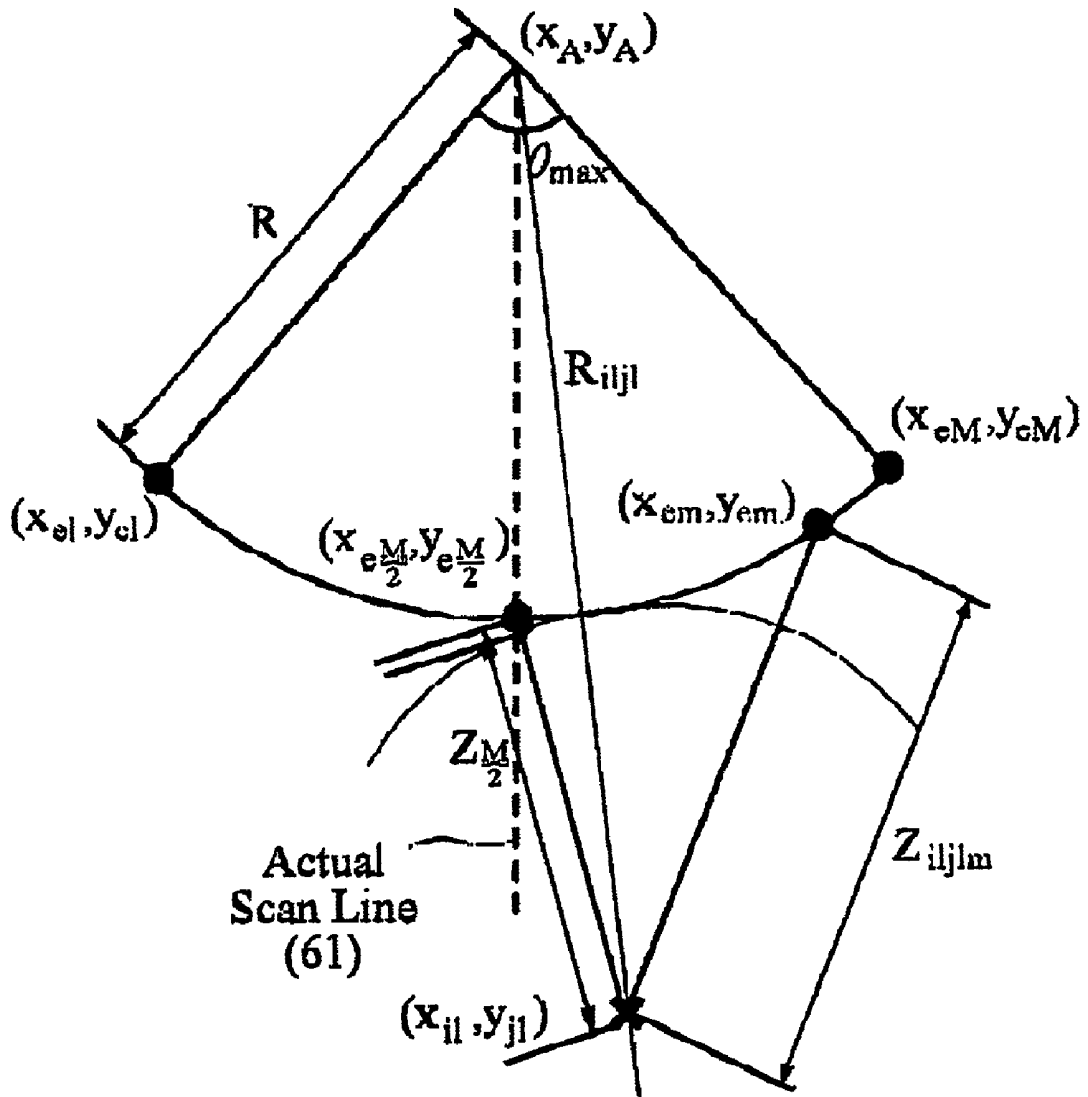

Fig. 8

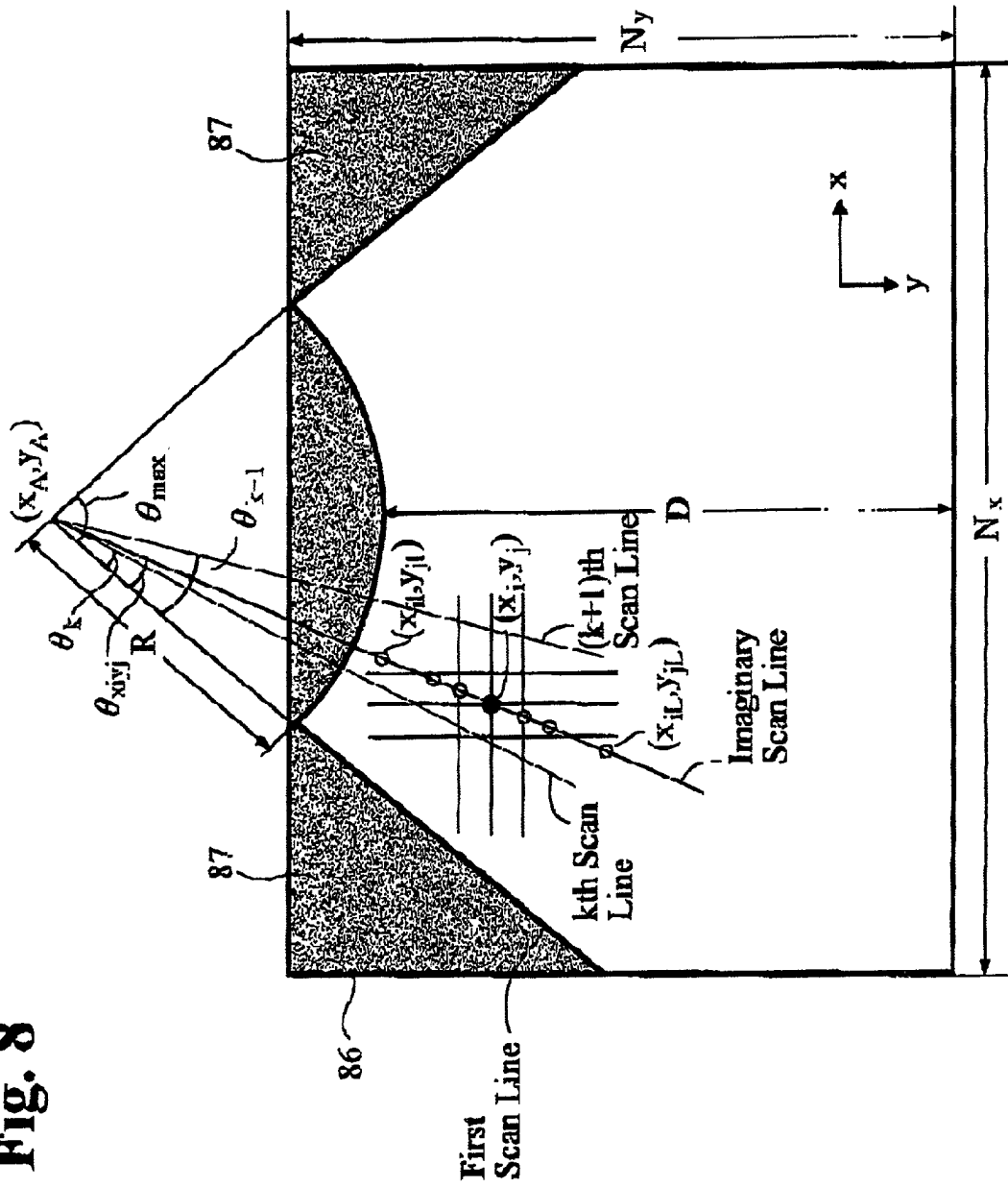

Fig. 9

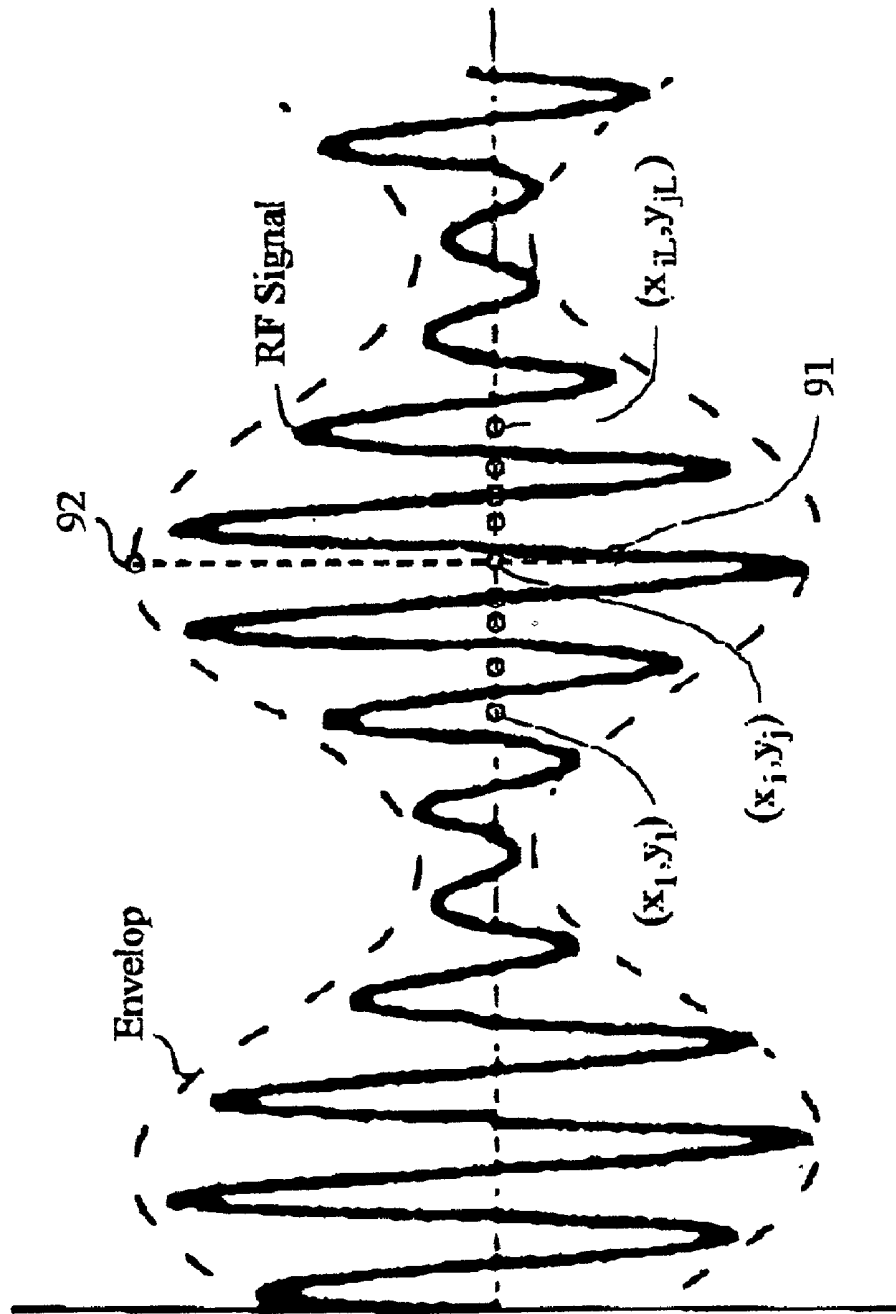

Fig. 10

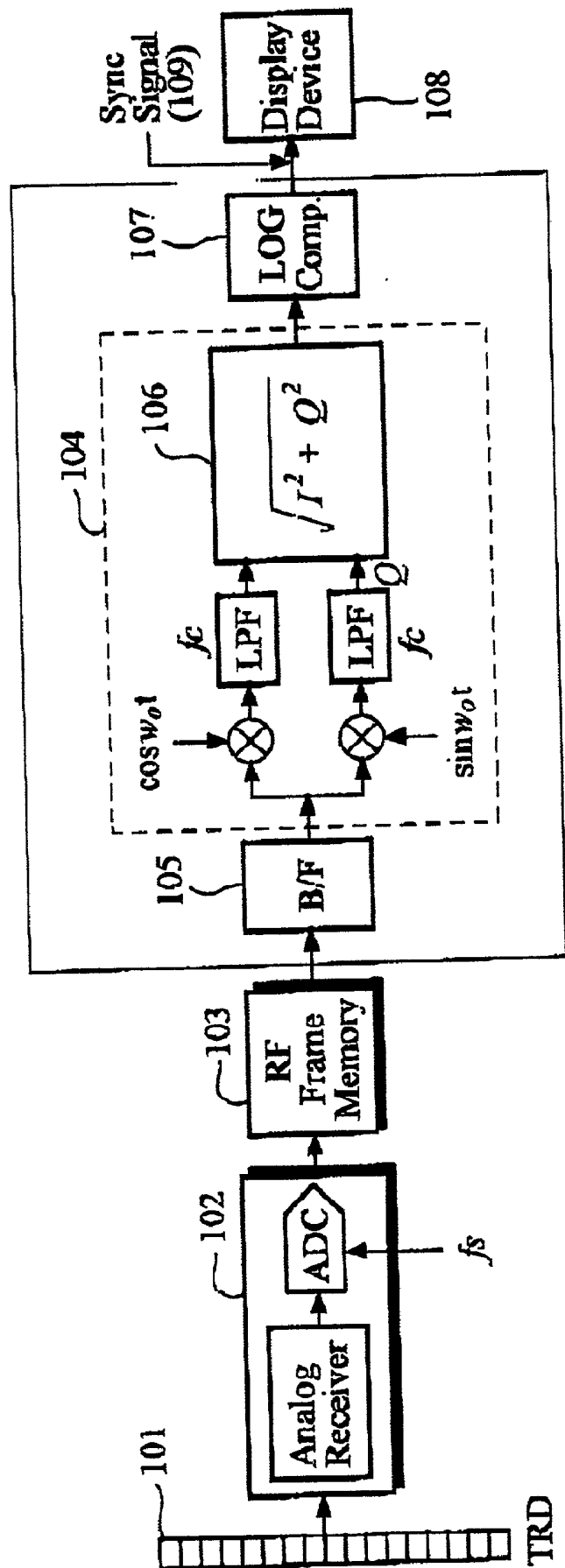

Fig. 11

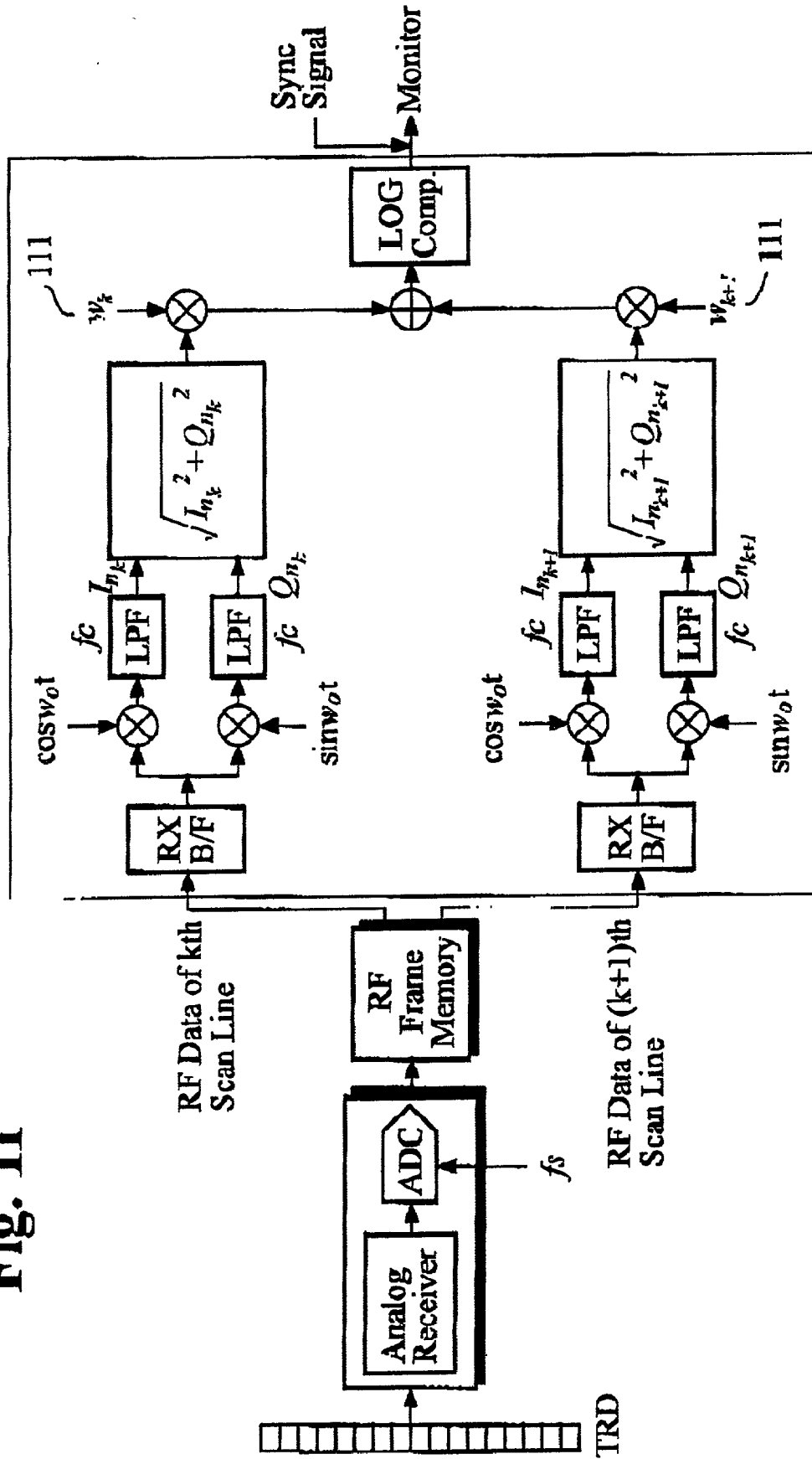

Fig. 12

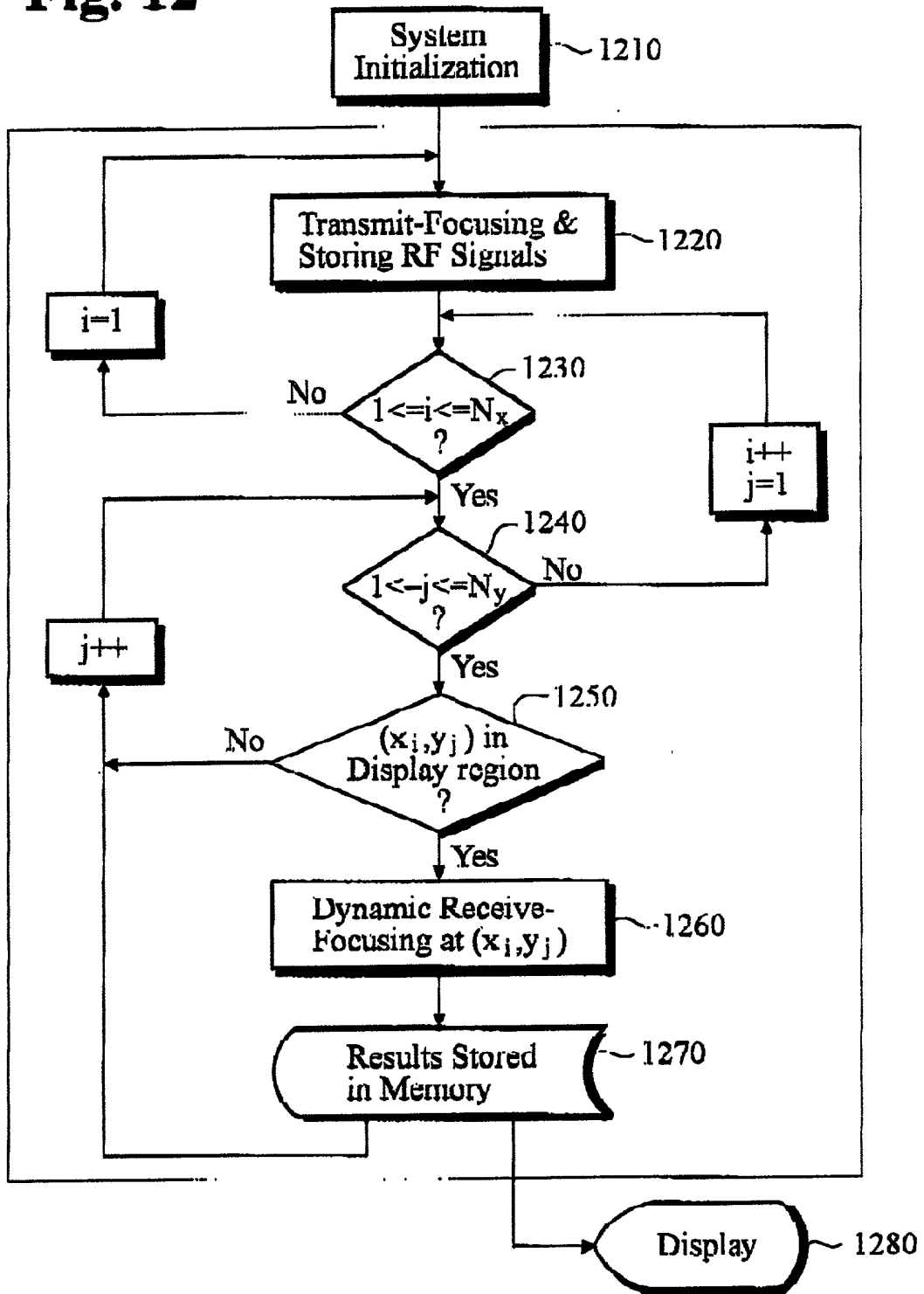

Fig. 13

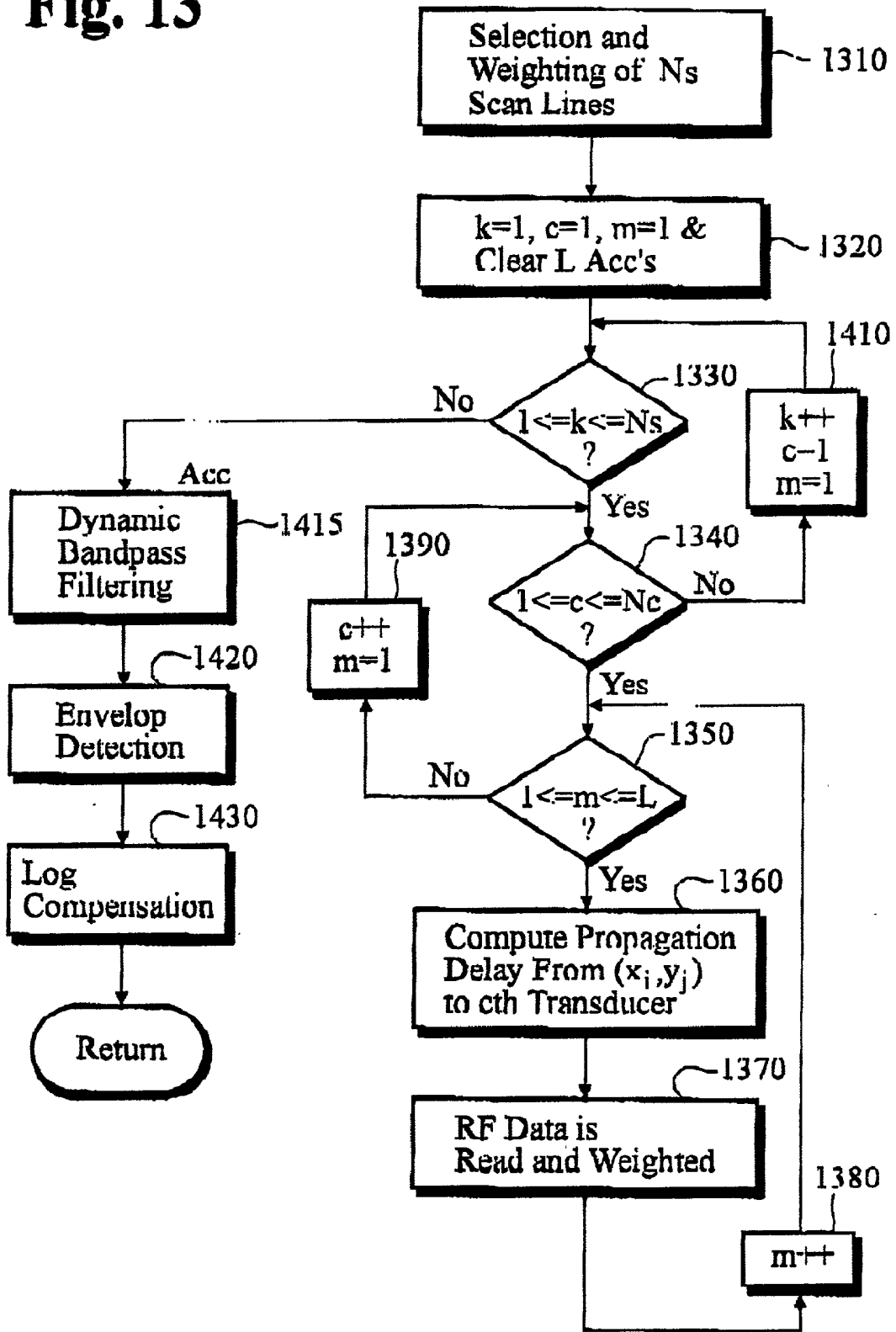
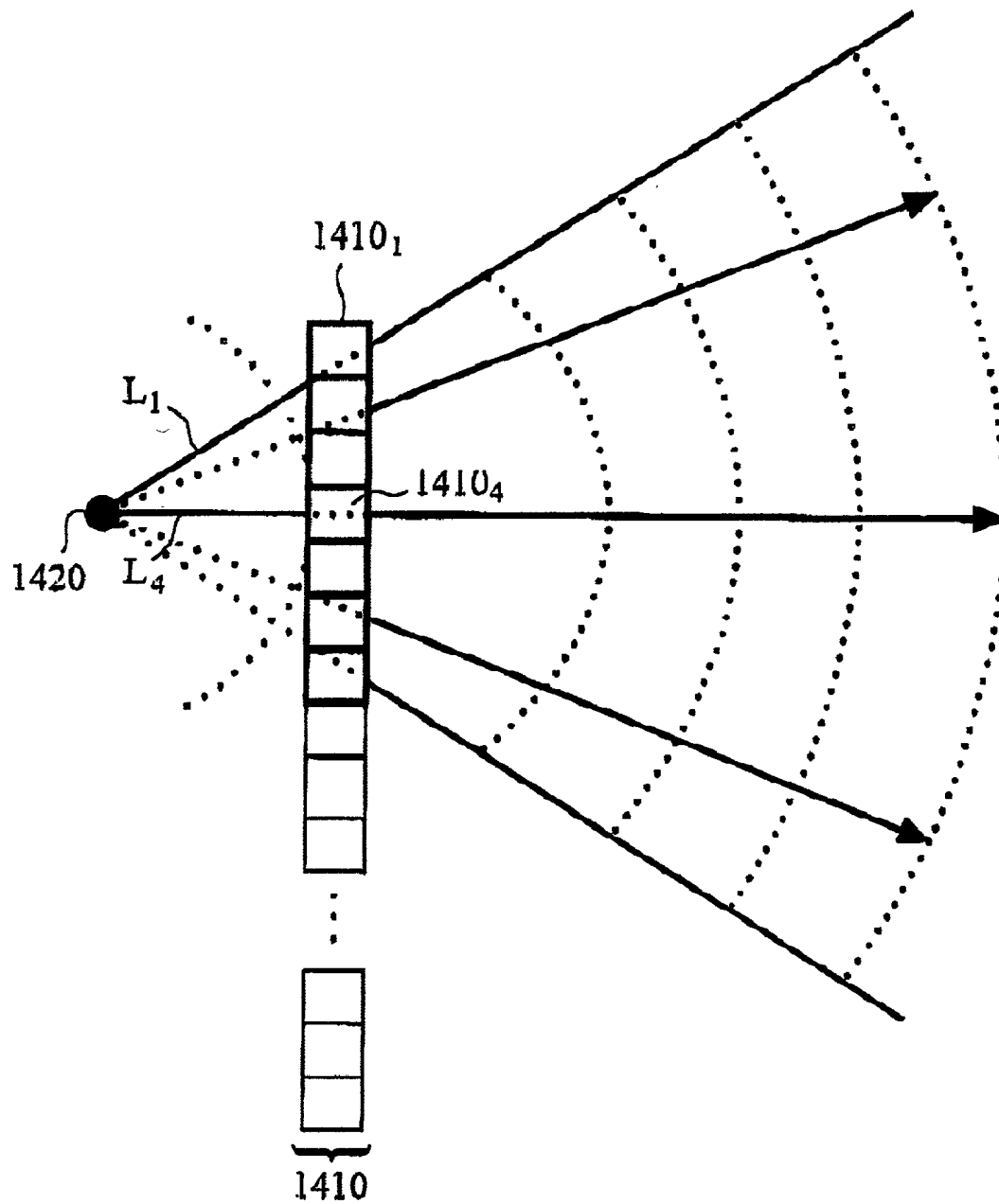

Fig. 14



**ULTRASOUND IMAGING SYSTEM FOR
PERFORMING RECEIVING FOCUSING AT
POINTS CORRESPONDING TO DISPLAY PIXELS
AND METHOD THEREOF**

FIELD OF THE INVENTION

[0001] The present invention relates to an imaging system and more particularly to an ultrasonic imaging system.

BACKGROUND OF THE INVENTION

[0002] Ultrasonic imaging systems are widely used in the medical diagnostic field for their ability to obtain the image of an object non invasively, i.e., by transmitting ultrasound to the object and processing its reflection. Conventional ultrasonic imaging systems have an array of ultrasound transducers or probes for generating ultrasound and receiving the ultrasound reflected off an object. Ultrasonic pulses from the array of ultrasonic transducers are focused to a desired point by controlling the timing of ultrasonic pulse generation at each of the transducers. FIG. 1 allows the timing control or ultrasound generation at an array of transducers in order to compensate propagation delay due to different distances from the transducers to a particular point. By sequentially delaying generation of ultrasonic pulse signals from the transducers, all the ultrasonic pulses simultaneously reach a point. Simultaneous reception of the reflected ultrasound from a particular point at the array of transducers is also made possible by sequentially adjusting receive timings of the transducers, where the greater the distance from a transducer to the point is the more receive delay is provided to the transducer. In order to obtain an accurate image of an object, transmit focusing to various points on the object is needed. But after transmitting ultrasonic pulses to be focused on a selected point, transmission to another point has to wait until all the reflected ultrasonic signals are received including one reflected from the farthest point. Increasing the number of transmit focal points has a drawback because it would also increase the amount of time required to obtain an image, thereby reducing the frame rate.

[0003] The frame rate in the case that each scan line transmits to focus on a single point is determined by the following equation.

$$1/FR=2D/v \times N$$

[0004] wherein FR, D, v and N represent the frame rate, depth of scan, velocity of ultrasound transmission in the medium, and the number of scan lines respectively. As can be seen from the equation, the frame rate is inversely proportional to the number of scan lines, presenting one with a trade-off between the two variables. As a solution, a radial scan pattern to cover the whole area of diagnosis has been conventionally with ultrasound sequentially applied along N number of the scan lines to predetermined points. Beside the radial scan pattern as illustrated in FIG. 2, a parallel scan line pattern has also been widely used. With these scanning methods receive focusing is achieved only on the points along the scan lines, limiting collection of information on an object to the points of the scan lines. Display devices generally have pixels arranged in a matrix on their screens and each pixel should be provided with display data to form an image. FIG. 3 shows a scan converter 32, using the data collected with dynamic receive focusing, to generate display data for the pixels of a display device. The scan converter

first stores data which are receive-focused from predetermined points on the scan lines and next converts it to a horizontal raster line display format used in most display devices. The information about a target object acquired by using the dynamic receive-focusing scheme is limited to focused points on the scan lines. These focused points do not necessarily coincide with actual pixel points of a display device that can represent the image of the target object (these actual pixel points corresponding to the pixel locations of the display device will simply be referred to as "pixel points" hereafter). Thus the scan converter has to perform interpolation to provide display data for all the pixels of the display device. For example, in the case of a radial scan pattern as shown in FIG. 4, because the distance between each pair of adjacent scan lines because greater as it is measured farther away from the transducers, the number of pixel points increases that do not have a one-to-one correspondence to points on the scan lines. As a result, display data for those pixel points can not be directly collected simply by the dynamic focusing. The scan converter determines display data for these pixels by interpolation using focused points on scan lines nearest to the pixels. Even in the case of parallel scan lines, some of the pixels in the display device may not correspond to those points on the scan lines. Thus a scan converter is still needed in a parallel scan-line ultrasonic imaging system.

[0005] FIG. 5 is a block diagram of an ultrasonic imaging system using the conventional dynamic receive focusing scheme. An array of transducers sequentially transmit ultrasound to be focused on desired points on the scan lines. After transmitting ultrasonic signals on a scan line, the transducers receive reflected ultrasonic signals and a beam-former focuses received ultrasound from a plurality of points on the scan lines. The function of the beam-forming part will be better understood referring to FIG. 6. It describes computation of ultrasound propagation delay in the case of receive focusing. It illustrates a case where M channels out of a total of M transducers are used for both transmission and reception, N channels being arranged in a curvilinear array with the radius R(mm) and transmission angle ϕ_{max} . When M channel/transducers disposed at the coordinates are used for receive focusing a point with Z distance on a scan line, the ultrasound propagation delay from the point (x, y) to an mth transducer is expressed as follows.

$$t_{dm} = t_{i,dm} + t_{v,dm} = \frac{Z}{v} + \frac{Z_m}{v}, Z_m = \sqrt{(x - x_{cm})^2 + (y - y_{cm})^2}$$

[0006] In order to discriminate a signal that was reflected from the point (x, y) from all the RF signals arrived at the mth transducer, a period of time from transmission to reception should be taken into account. In the above equation, the term $t_{i, dm}$ represents the time the ultrasound took from transmission start to reach the point and the term $t_{v, dis}$ represents the time the reflection took from the point (x,y) to the mth transducer. At the time of transmission all the transducers are controlled to transmit respective ultrasonic signals such that they arrive simultaneously at a predetermined point. It can be assumed that the times ultrasound travel from each transducer to the point are the same. By using the ultrasound propagation delay, each transducer reads a reflection signal it receives from the point and, by

adding these reflection signals together, an receive-focused data as to the point is obtained.

[0007] Referring back to FIG. 5, by repeating the receive-focus for a plurality of points along each scan line, an image of a target object can be obtained. These data are converted by a scan converter to appropriate values corresponding to pixels in a display device. The beam former (52) stores those data which are receive-focused at the points along the scan lines. In this process some of information in the reflection signals are lost. As shown in FIG. 4, because data associated with points between adjacent scan lines are not provided by the beam-former, the scan converter creates the image data, of these in-between points by interpolation using the image data of the adjacent scan lines. The interpolation, however, results in a distorted image. In order to reduce the distortion, the number of scan lines should be increased so that missing data between scan lines can be reduced but this presents a problem for an ultrasonic image system requiring real-time and high frame rate. Thus an ultrasonic image system which can prevent image distortion without increasing the number of scan lines has been needed.

BRIEF DESCRIPTION OF DRAWINGS

[0008] FIG. 1 shows a transducer array in three different delay modes;

[0009] FIG. 2 shows a transducer array that sequentially focuses on a point on radial scan lines;

[0010] FIG. 3 is a block diagram illustrating the function of a scan converter that converts receive-focused signals from transducers to a display data;

[0011] FIG. 4 shows pixel locations in a display device that are not on actual scan lines;

[0012] FIG. 5 is a block diagram of a conventional dynamic receive-focus ultrasonic image system;

[0013] FIG. 6 illustrates propagation delay of receive-focus in a conventional ultrasonic image system;

[0014] FIG. 7 illustrates propagation delay from a pixel point when received focused;

[0015] FIG. 8 illustrates determination of display data for a pixel using the data of an adjacent scan line;

[0016] FIG. 9 illustrates comparison between received-focused RF signals and a value on the envelop;

[0017] FIG. 10 is a block diagram of ultrasonic image system that receive-focuses on a pixel according to the present invention;

[0018] FIG. 11 is a block diagram of ultrasonic image system that utilizes two adjacent scan lines for determining data for a pixel;

[0019] FIG. 12 is a flow chart for dynamic receive focusing according to the present invention;

[0020] FIG. 13 is a flow chart for steps performed in step 1260 of FIG. 12; and

[0021] FIG. 14 illustrates propagation delays applied to transducers for de-focusing transmitted ultrasonic signals.

SUMMARY OF THE INVENTION

[0022] A receive-focus scheme according to the present invention stores all RF data the transducers receive and directly receive-focuses at points corresponding to pixels by using the stored data. With this scheme, the distortion due to conventional interpolation used for a limited number of scan lines can be greatly reduced. The present invention is particularly useful in a high frame rate, high resolution system having a wide transmission angle or in a smaller system that can not afford expensive hardware such as a digital scan converter.

DETAILED DESCRIPTION OF THE INVENTION

[0023] Pixel-based received focusing according to an embodiment of the present invention will be described referring to FIG. 7. FIG. 7 illustrates the calculation of propagation delay of ultrasound from a pixel point, a point of the target object that can be represented by the matrix of the display screen, as defined above, according to the present invention. As mentioned earlier, a pixel point is not necessarily located on the scan lines. The present invention is directed to receive-focusing ultrasound from all the pixel points as opposed to merely from scan line points. First the time it takes for ultrasound to propagate from an arbitrary point of (x_{i1}, y_{j1}) , that does not necessarily correspond to a pixel point of a display screen, to an m th transducer at (x_{em}, y_{em}) is as follows.

$$t_{dm} = t_{i,dm} + t_{r,dm} = \frac{Z_M}{v} + \frac{Z_{ijlm}}{v},$$

$$Z_M = \sqrt{(x_{i1} - x_{eM})^2 + (y_{j1} - x_{yM})^2},$$

$$Z_{ijlm} = \sqrt{(x_{i1} - x_{em})^2 + (y_{j1} - x_{ym})^2}$$

[0024] , where $t_{i,dm}$ is the propagation time to a pixel point (x_{i1}, y_{j1}) and $t_{r,dm}$ is the propagation time from a pixel point (x_{i1}, y_{j1}) to an m th transducer. Once the propagation time from a predetermined pixel point is calculated by using the above equation, the ultrasonic signal reflected from the pixel point and received by the transducer is discriminated based on the calculated propagation time. After reflected ultrasonic signals from the same point and received by all other transducers are likewise discriminated using Equation 3, they are added together to produce the characteristics of reflected ultrasonic signal from that point. With this method, interpolation is not needed to generate display data for all the pixel points.

[0025] FIG. 8 illustrates computing the display data for a pixel of a display screen by using an adjacent actual scan line to the pixel point, according to one embodiment of the present invention. Here, M channels/transducers out of a total of N channels are used for transmission/reception on a preselected scan line. Further, the radius or curvature of the curvilinear array of transducers is R (mm) with the scan angle and depth being θ_{max} , and D (mm) respectively, RF data inputted from the array of transducers are all stored as follows. After transmit-focusing ultrasound on one of N scan lines that are radially spaced apart each by an angle $\Delta\theta$ with

respect to the apex of the curve, reflected ultrasonic signal to each of M transducers is sampled at a predetermined frequency of f_c and stored. The rectangular perimeter (86) of FIG. 8 represents the shape of a display screen where the ultrasonic image is ultimately to be displayed. The screen is shown to have Nx pixels in a row and Ny in a column such that it has a total of NxNy pixels.

[0026] Below it is described how a direct receive focusing from a pixel point (x_i, y_i) ($1 \leq i < Nx$, $1 < j \leq Ny$) is achieved by using the data of the most adjacent actual scan line. First an actual scan line that is closest to an imaginary scan line extending from a selected pixel point to the apex and meets the following equation is identified.

$$\text{Minimize}|\theta_{xyi}-\theta_k|, 1 \leq k \leq N$$

[0027] , wherein $\theta_{xi, yi}$ is the angle between the imaginary scan line and the first actual scan line and θ_k is the angle between the kth actual scan line and the first actual scan line. Once an actual scan line that is closest to an imaginary scan line is found, the direct receive focusing from a pixel point (x_i, y_i) is achieved by using RF data received after ultrasound was transmit-focused on the kth actual scan line. Receive-focused data about L points near the pixel point, including the pixel point itself, on the imaginary scan line are obtained in order to generate the display data of the pixel point. Data about a plurality of points around a selected pixel (x_i, y_i) will not be used directly but a corresponding envelop of a waveform formed L points is used to determine display data for the pixel point. Specifically, ultrasonic signal information with respect to L points from a point (x_{i1}, y_{j1}) to a point (x_{iL}, y_{jL}) on the imaginary scan line are computed by receive focusing. A waveform represented by the information is determined as shown in FIG. 9. Though the actually detected signal at the pixel point of interest is represented by a small circle 91, the peak, represented by a circle 92, of the waveform is determined to be the effective data for the pixel. This process is repeated for all the other pixel points in order to display a whole image of the target object. FIG. 10 schematically an imaging system according to the present invention. Received signals at the transducer array 101 are sampled at a predetermined frequency f_s by an ADC (102), digitized and stored at a frame memory (103). Thus, RF data received by all the transducers get stored in the frame memory. Data needed to be stored in order to display a single image are obtained by repeating the steps of transmit-focusing on a scan line, receiving the RF signal at M transducers and sampling the RF signal for all N scan lines. The size of memory required for storing data of one frame for a scan depth D, thus, is as follows.

$$N \cdot M \cdot \frac{2D}{v} \cdot f_s$$

[0028] A signal processing module (104) that generates display data of each pixel is composed of a beam former (B/F, 105), an envelop detector (106) and a log compensator (107). The beam former, using the data stored in the frame memory, computes data that was dynamically receive focused at points along the imaginary scan line including a pixel point (x_1, y_1) and the apex (x_A, y_A) and provides the data to the envelop detector.

[0029] An embodiment shown in FIG. 10 illustrates the use of a quadrature demodulator for envelop detection. The present invention, however, is not limited to the quadrature demodulation but any suitable envelop detection methods can be used.

[0030] Ultrasound does not attenuate uniformly across at all the frequencies when it propagate in a material. Higher frequency ultrasound attenuates much faster than lower frequency ultrasound. High frequency ultrasound decreases as it travels farther. Therefore, the output signal from the beam former preferably should pass a dynamic hand pass filter, whose pass band varies depending on the traveled distance of a received ultrasonic signal. In FIG. 10, by changing the frequency ω_0 of a sine or cosine signal that is multiplied to the output of the beam former and the cut-off frequency f_c of low pass filter, dynamic band passing can be performed in the envelop detector (106). Alternatively a separate dynamic band pass filter may be used.

[0031] The output of the envelop detector is provided to a display device (108) via a log compensator (107). The log compensator compensates differences in dynamic ranges of the envelop detector and the display device. As explained above, the receive focusing at a pixel point is repeated for all the other pixel points to form a whole image that fits a screen.

[0032] The RF frame memory (103) is comprised of a plurality of memory devices that can store image frames in order to display images in real time. Specifically, while data stored in one frame memory is used to display an image, another frame memory should be able to store RF data for the next frame.

[0033] Although a single actual scan line closest to a selected pixel point was used in the aforementioned embodiment, the present invention is not limited to that embodiment. For example the kth scan line and (k+1)th located on either side of a pixel point respectively may be used. FIG. 11 is a block diagram for such an embodiment utilizing two adjacent actual scan lines. The embodiment includes a circuit that processed RF data stored in the memory about the kth actual scan line and another circuit that processes RF data also stored in the memory about the (k+1)th scan line, and adding the weighted outputs of respective envelop detectors. This embodiment also preferably performs the dynamic band pass filtering. The weights w_k, w_{k-1} multiplied to the envelop detector outputs, as shown in FIG. 11, are obtained as follows.

$$w_m = \frac{d\theta_{k+1}}{\theta_{k+1} - \theta_k}, d\theta_{k+1} - \theta_{k+1} - \theta_{xyi}$$

$$w_{k+1} = \frac{d\theta_k}{\theta_{k+1} - \theta_k}, d\theta_k - \theta_{xyi} - \theta_m$$

[0034] wherein θ_k and θ_{k+1} represent the angle between the first scan line and the kth, and the angle between the first scan line and the (k+1) scan line respectively. Just like the embodiment illustrated in FIG. 10 the RF frame memory is comprised of a plurality of memory devices that can store image frames in order to display images in real time.

[0035] FIG. 12 is a flow chart that explains a receive focusing method in accordance with the present invention.

At step (1210) the ultrasonic image system is initialized to set system parameters such as the scan depth and the number of total scan lines. Additionally, in order to receive focus in accordance with the present invention, are set the number of pixels in X and Y directions of a display device, the number of points along an imaginary scan line and the number of adjacent actual scan lines that will be used to obtain a pixel data.

[0036] At step (1220), after transmit focusing on each of scan lines, RF signals received at Nc transducers are stored in the RF frame memory. The RF memory, as mentioned above, is comprised of a plurality of memory segments, each of which can store data for a single image frame, such that, while step 1230 is performed using data stored in one frame memory segment, RF data for the next image frame can be stored in another memory segment.

[0037] At step (1230), if variable i is determined to be between 1 and Nx, the next step 1240 is taken. Otherwise, i is set to 1 and step 1220 is repeated to store RF signals for the next image, since all the pixel data needed for the first image have been obtained.

[0038] At step 1240, if variable j is determined to be between 1 and Ny, the next step 1250 is taken. Otherwise, data for all the pixels for a Y-direction line have been obtained. Accordingly j is set to 1 and i is incremented by one and step 1230 is repeated for the next line.

[0039] At step 1250, it is checked whether a pixel point (x_i, y_j) is located in the display region of the imaging system. As shown in FIG. 8, in the rectangular screen of a display device there exist areas 87 that are not covered by the ultrasonic image system because of the radial scan line direction. If the current pixel to be processed is in one of these non-image areas, then j is incremented by one and step 1240 is repeated for the next pixel point. Otherwise, at step 1260 a display data is obtained by receive focusing at the pixel (x_i, y_j) using the RF data of Ns actual scan lines that are near to the pixel (x_i, y_j) .

[0040] Display data acquired at step 1260 is stored in the display memory at step 1270. After storage, j is incremented by one and step 1240 is repeated for obtaining and storing data for the next pixel point. The data in the display memory is used at step 1280 for display.

[0041] FIG. 13 is a flow chart for explaining operations at step 12, relating to obtaining receive-focused data at a pixel (x_i, y_j) using RF data of Ns adjacent actual scan lines. At step 1310, Ns scan lines near the pixel (x_i, y_j) are selected and a weighting factor for each scan line is determined. The weighting factors are set inversely proportional to the distance between an imaginary scan line and an actual scan line.

[0042] At step 1320, variables k, G and m are all set to 1 and an array of L accumulators (Acc[m]) are cleared. The variable k is used to identify Ns actual scan lines near to the pixel point (x_i, y_j) . The variable c is used to identify Nc transducers that transmit-focus ultrasonic signals to an actual scan line and receive reflected signals. The variable m is used to indicate each of L receive-focused points on an imaginary scan line including the pixel for envelop detection. The flow chart of FIG. 13 shows three loops. The first and innermost loop includes steps 1350-1380. The second loop is comprised of steps 1340-1390, including the first loop. The third and outermost loop is comprised of steps 1330-1310, including the second loop. While the third loop

iterates one time, the second loop iterates Nc times. In the meantime the third loop iterates Ns times.

[0043] The first loop determines a portion of receive-focused data, at L points on an imaginary scan line, attributable to RF data received by a cth transducer among Nc transducers after the kth actual scan line is transmit focused. In order to elaborate on the first loop of FIG. 8, steps for obtaining receive-focused data at L points, (x_{i1}, y_{j1}) – (x_{iL}, y_{jL}) , on an imaginary scan line including the pixel (x_i, y_j) will be described. In case that the variable m is equal to 1, propagation delay of an ultrasonic signal reflected from a point (x_{i1}, y_{j1}) to a cth transducer is calculated using the formula described in connection with FIG. 8. At step 1370, using the calculated propagation delay, RF data received at the cth transducer is read and the result is multiplied by a weighting factor for the kth actual scan line and accumulated to Acc[1]. At step 1380, m is incremented by one and the first loop, starting with step 1350, is repeated. Since m is now 2, the above steps are repeated for a point (x_{i2}, y_{j2}) and the computed value is accumulated to Acc[2]. By iterating the first loop L times, weighted results for all L points, as seen by the cth transducer, on the imaginary scan line are accumulated in the accumulator. At step 1390, by incrementing c by one and setting m back to 1 and iterating the first loop for another L times, receive-focused data for L points, as seen by the next transducer, are calculated and stored. By repeating the second loop Nc times, contributions by RF data received at Nc transducers to each of the L receive-focused data on L points are determined. Finally, by repeating the third and outermost loop Ns times, final data receive-focused at L points are computed using data of Ns actual scan lines.

[0044] By the time iterations in all the loops are over, L accumulators will have stored receive-focused data at L points on an imaginary scan line including the pixel point (x_i, y_j) . At step 1415, the data in the accumulators are bandpass filtered. At step 1420 the envelop is detected from the bandpass filtered data. At step 1430 log compensation is provided. As explained in reference to FIG. 10, the envelop detection step may include the function of the dynamic bandpass filtering.

[0045] As mentioned above, a preferred embodiment of an ultrasonic image system was described but the present invention is not limited to that particular embodiment. Modifications may be made to the embodiment. For instance, the preferred embodiment showed transmit focusing on radially patterned scan lines. But the present invention is not limited to such a scan line pattern. Parallel scan lines in the case of linear array of transducers are commonly used in transmit-focus ultrasonic image system. Even in this situation pixel points may not be located on the scan lines. The present invention may be used in this type of ultrasonic image system and the quality of images will be improved by directly receive focusing on pixel points.

[0046] Additionally, in a preferred embodiment, a transmitted ultrasonic signal is focused on a single point on each scan line. However, the present invention may be used in a case that the signal is not focused on a single point, i.e., in case that a transmitted ultrasonic signal is de-focused. FIG. 14 illustrates time delays applied to transducers in order to de-focus ultrasonic signal. As shown in the figure, de-focused ultrasonic signal propagates radially as if it was generated from an imaginary point 1420 behind the transducer array 1410. If each of the transducers is activated to generate a same ultrasonic signal at the time an ultrasonic

signal would have arrived thereto from the imaginary point 1420, the transmitted ultrasonic signals would appear to have been all generated from the imaginary point and propagate in the radial direction. As a result a transducer closest to the imaginary point would generate the ultrasonic signal before others do. The farther a transducer is away from the imaginary point, the later it starts to transmit the ultrasonic signal. For example, a transducer 1410, transmits after a transducer 1410₄ with a predetermined delay. The delay is expressed as follows.

$$\text{Delay} = L_1 - L_2 / v$$

[0047] where L_1 and L_2 are the distances between each of the transducers 1410₁, 1410₄ and the imaginary point respectively, and v is the velocity of the ultrasonic signal.

[0048] After ultrasonic signal is transmitted so as to be de-focused, signals received at the transducers are stored. The propagation delay for the reflected signal from the pixel point to each transducer is computed. By adding the received signals by taking into account the delays, the ultrasonic signal's value focused at the pixel is obtained.

[0049] When ultrasonic signals are transmitted to be focused at a point on a scan line, the image of pixels distant from the focal point deteriorate. But, as mentioned above, if transmitted ultrasonic signals are de-focused the fluctuation of image quality depending on pixel location is prevented.

What is claimed is:

1. An ultrasonic image system comprising:
 - a display device,
 - ultrasound transducers for transmitting ultrasonic signals toward an object,
 - a storage means for storing signals received at said ultrasound transducers in response to said transmitted ultrasonic signals and
 - a processing means for determining the receive-focused signal from a selected point of said object, corresponding to a pixel in said display device.
2. An ultrasonic image system as claimed in claim 1, wherein said transducers transmit-focus ultrasonic signals at a point on a scan line and receive reflected signals, and said processing means determines characteristics of the reflected signals received by each of said transducers from multiple points on an imaginary scan line in response to said ultrasonic signals transmitted on said scan line, wherein said imaginary scan line includes said selected point and is closest to said actual scan line for computing display data for said selected point.
3. An ultrasonic image system as claimed in claim 1, wherein said transducers transmit-focus ultrasonic signals at a point on each of a plurality of scan lines, and said processing means determines characteristics of the reflected signals received by each of said transducers from multiple points on an imaginary scan line in response to said ultrasonic signals transmitted on at least two of said plurality of scan lines, wherein said imaginary scan line includes said selected point and are between said at least two scan lines for computing display data for said selected point.
4. An ultrasonic image system as claimed in claim 3, wherein said characteristics of the reflected signals from said multiple points are weighted according to on which one of said at least two scan lines said ultrasonic signals were transmit-focused.

5. An ultrasonic image system comprising:

a display device,

ultrasound transducers adapted to transmit ultrasonic signals, each with a time delay, toward an object so as to be de-focused,

a storage means for storing reflected signals received at each of said transducers in response to said transmitted ultrasonic signals and,

a processing means for determining display data for a selected point of said object that corresponds to a pixel of said display device, by determining characteristics of said reflected signals received by each of said transducers from multiple points on an imaginary scan line, including said selected point.

6. A method for displaying an image of an object by transmitting an ultrasonic signal toward said object and receiving the reflected signal of the ultrasonic signal from said object comprising the steps of:

transmitting an ultrasonic signal to be focused to a point on each of predetermined scan lines that encompass said object,

receiving and storing the reflected signal of said ultrasonic signal,

computing display data for a selected point of said object that corresponds to a pixel of a display device, by determining characteristics of reflected signals received by each of said transducers from multiple points on an imaginary scan line, including said selected points, said reflected signals being in response to said transmitted ultrasonic signal on one of said predetermined scan lines, which is nearest to said imaginary scan line, and

repeating said computing step for all other pixels of said display device.

7. A method for displaying an image of an object as claimed in claim 7, said computing step uses the reflected signals from said multiple points in response to said ultrasonic signals that were transmit-focused on at least two scan lines and said imaginary scan line is located between two of said at least two scan lines.

8. A method for displaying an image of an object by transmitting an ultrasonic signal toward said object and receiving the reflected signals of the ultrasonic signal from said object comprising the steps of:

transmitting ultrasonic signals, each with a time delay, so as to be de focused,

receiving and storing the reflected signals of said ultrasonic signals,

computing a receive focused ultrasonic signal at a point of said object that corresponds to a pixel in the screen of a display device, using the received and stored signals, and

repeating said computing step for all other pixels of said display device.

| | | | |
|---------------|---|---------|------------|
| 专利名称(译) | 用于在对应于显示像素的点处执行接收聚焦的超声成像系统及其方法 | | |
| 公开(公告)号 | US20010020129A1 | 公开(公告)日 | 2001-09-06 |
| 申请号 | US09/785968 | 申请日 | 2001-02-16 |
| 申请(专利权)人(译) | MEDISON CO. , LTD. | | |
| 当前申请(专利权)人(译) | MEDISON CO. , LTD. | | |
| [标]发明人 | HWANG JAE SUB SONG TAI KYONG | | |
| 发明人 | HWANG, JAE SUB SONG, TAI KYONG | | |
| IPC分类号 | A61B8/00 G01S7/52 G01S15/89 | | |
| CPC分类号 | G01S7/52044 G01S7/52046 G01S7/52053 G01S15/8906 | | |
| 优先权 | 1020000007236 2000-02-16 KR | | |
| 其他公开文献 | US6648824 | | |
| 外部链接 | Espacenet USPTO | | |

摘要(译)

响应于在预定扫描线上的点上发送聚焦的超声信号而由换能器接收的所有RF数据被存储以计算对象的那些点的显示数据，所述对象不一定对应于a的屏幕的像素。显示设备。为了确定每个像素点的显示数据，找到来自感兴趣点周围的多个点的反射超声信号，并用于检测由反射的超声信号构成的波形的峰值。利用该方案，可以大大减少由于用于有限数量的扫描线的传统插值引起的失真。

