

US009060669B1

(12) **United States Patent**  
**Mo et al.**

(10) **Patent No.:** **US 9,060,669 B1**  
(45) **Date of Patent:** **Jun. 23, 2015**

(54) **SYSTEM AND METHOD FOR PROVIDING VARIABLE ULTRASOUND ARRAY PROCESSING IN A POST-STORAGE MODE**

4,852,577 A 8/1989 Smith et al.  
5,161,535 A 11/1992 Short  
5,260,871 A 11/1993 Goldberg  
5,269,289 A 12/1993 Takehana et al.

(Continued)

(75) Inventors: **Larry Y. L. Mo**, San Ramon, CA (US); **Glen W. McLaughlin**, San Carlos, CA (US); **Brian Derek DeBusschere**, Orinda, CA (US); **Ting-Lan Ji**, San Jose, CA (US); **Albert Gee**, Los Altos, CA (US); **David J. Napolitano**, Pleasanton, CA (US); **Ching-Hua Chou**, Mountain View, CA (US); **Robert W. Steins**, San Jose, CA (US)

FOREIGN PATENT DOCUMENTS

WO WO 2008/051738 A2 5/2008

OTHER PUBLICATIONS

Anderson, M.E., et al., "The Impact of Sound Speed Errors on Medical Ultrasound Imaging", *J. Acous. Soc. of Am.*, Jun. 2000, pp. 3540-3548, vol. 107, No. 6.

(Continued)

(73) Assignee: **ZONARE MEDICAL SYSTEMS, INC.**, Mountain View, CA (US)

(\* ) Notice: Subject to any disclaimer, the term of this patent is extended or adjusted under 35 U.S.C. 154(b) by 1268 days.

Primary Examiner — Peter Luong

(74) Attorney, Agent, or Firm — Kory D. Christensen; Stoel Rives LLP

(21) Appl. No.: **12/340,578**

(22) Filed: **Dec. 19, 2008**

(57) **ABSTRACT**

**Related U.S. Application Data**

(60) Provisional application No. 61/015,632, filed on Dec. 20, 2007.

(51) **Int. Cl.**  
**A61B 8/00** (2006.01)

(52) **U.S. Cl.**  
CPC ..... **A61B 8/00** (2013.01); **A61B 8/4488** (2013.01)

(58) **Field of Classification Search**  
USPC ..... 600/437  
See application file for complete search history.

An ultrasonic imaging method includes activating a transmit aperture within a multi-element transducer array, transmitting one or more ultrasonic beams along scan direction(s) that span the region of interest, for each transmit event, receiving ultrasonic echoes from each element of a receive aperture, grouping the receive channel echo data into two or more sets corresponding to different receive sub-apertures, combining each sub-aperture data set to generate partially focused echo-location data for one or more reconstruction lines, and storing all the sub-aperture echo data sets during a storage period in a format that can be retrieved for later analysis. A method includes, during a post-storage period, retrieving stored sub-aperture data, combining the sub-aperture data to form one or more selected reconstruction lines, processing echo data to extract motion information from one or more sample positions along the selected reconstruction lines, and displaying an image representative of the processed motion information.

(56) **References Cited**

U.S. PATENT DOCUMENTS

4,265,126 A 5/1981 Papadofrangakis et al.  
4,604,697 A 8/1986 Luthra et al.  
4,852,576 A 8/1989 Inbar et al.

**31 Claims, 5 Drawing Sheets**

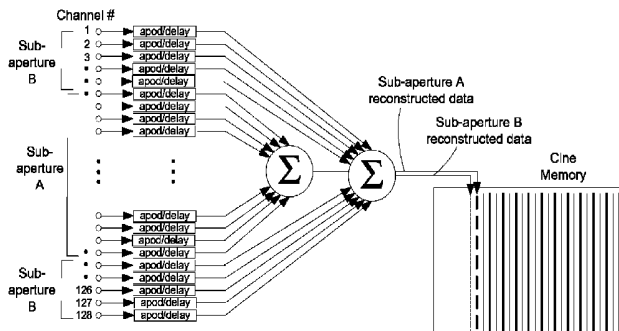

(56)

## References Cited

## U.S. PATENT DOCUMENTS

5,313,948 A 5/1994 Murashita et al.  
 5,357,962 A 10/1994 Green  
 5,357,965 A 10/1994 Hall et al.  
 5,365,929 A 11/1994 Peterson  
 5,409,010 A 4/1995 Beach et al.  
 5,415,173 A 5/1995 Miwa et al.  
 5,417,215 A 5/1995 Evans et al.  
 5,555,534 A 9/1996 Maslak  
 5,566,674 A 10/1996 Weng  
 5,579,768 A 12/1996 Klesenski  
 5,581,517 A 12/1996 Gee et al.  
 5,617,862 A \* 4/1997 Cole et al. .... 600/459  
 5,623,928 A 4/1997 Wright et al.  
 5,654,509 A 8/1997 Miele et al.  
 5,690,111 A 11/1997 Tsujino  
 5,720,289 A 2/1998 Wright et al.  
 5,776,063 A 7/1998 Dittrich et al.  
 5,782,766 A 7/1998 Weng et al.  
 5,799,111 A 8/1998 Guissin  
 5,857,973 A 1/1999 Ma et al.  
 5,871,019 A 2/1999 Belohlavek  
 5,935,074 A 8/1999 Mo et al.  
 5,954,653 A 9/1999 Hatfield et al.  
 5,984,870 A 11/1999 Giger et al.  
 5,993,393 A \* 11/1999 Ryan et al. .... 600/463  
 6,016,285 A 1/2000 Wright et al.  
 6,036,643 A 3/2000 Criton et al.  
 6,042,545 A \* 3/2000 Hossack et al. .... 600/443  
 6,068,598 A 5/2000 Pan et al.  
 6,069,593 A 5/2000 Lebby et al.  
 6,102,859 A 8/2000 Mo  
 6,110,119 A 8/2000 Hall  
 6,113,544 A 9/2000 Mo  
 6,120,446 A 9/2000 Ji et al.  
 6,142,943 A 11/2000 Mo et al.  
 6,162,176 A 12/2000 Washburn et al.  
 6,193,663 B1 2/2001 Napolitano et al.  
 6,221,020 B1 4/2001 Lysyansky et al.  
 6,263,094 B1 7/2001 Rosich et al.  
 6,312,385 B1 11/2001 Mo et al.  
 6,315,728 B1 11/2001 Muzilla et al.  
 6,322,509 B1 11/2001 Pan et al.  
 6,358,205 B1 3/2002 Ustuner et al.  
 6,390,983 B1 5/2002 Mo et al.  
 6,398,733 B1 6/2002 Simopoulos et al.  
 6,423,003 B1 7/2002 Ustuner et al.  
 6,434,262 B2 8/2002 Wang  
 6,450,959 B1 9/2002 Mo et al.  
 6,464,637 B1 10/2002 Criton et al.  
 6,464,640 B1 10/2002 Guracar et al.  
 6,464,641 B1 10/2002 Pan et al.  
 6,468,218 B1 10/2002 Chen et al.  
 6,491,636 B2 12/2002 Chenal et al.  
 6,497,661 B1 12/2002 Brock-Fisher  
 6,503,203 B1 1/2003 Rafter et al.  
 6,512,854 B1 1/2003 Mucci et al.  
 6,547,737 B2 4/2003 Njemanze  
 6,577,967 B2 6/2003 Mo et al.  
 6,679,847 B1 1/2004 Robinson et al.  
 6,860,854 B2 3/2005 Robinson et al.  
 6,926,671 B2 8/2005 Azuma et al.

6,932,770 B2 8/2005 Hastings et al.  
 6,980,419 B2 12/2005 Smith et al.  
 7,022,075 B2 4/2006 Grunwald et al.  
 7,627,386 B2 12/2009 Mo et al.  
 2004/0068188 A1 \* 4/2004 Robinson ..... 600/447  
 2004/0179332 A1 9/2004 Smith et al.  
 2006/0074320 A1 4/2006 Yoo et al.  
 2006/0079778 A1 4/2006 Mo et al.  
 2008/0146922 A1 6/2008 Steins et al.  
 2010/0189329 A1 7/2010 Mo et al.

## OTHER PUBLICATIONS

Freeman, S., "Retrospective Dynamic Transmit Focusing", *Ultrasonic Imaging* 17, 1995, pp. 173-196.  
 Gammelmark, K.L., et al. "Multi-Element Synthetic Transmit Aperture Imaging using Temporal Encoding", 2002 SPIE Medical Imaging Meeting, Ultrasonic Imaging and Signal Processing, 2002; pp. 25-36.  
 Haider, B., "Synthetic Transmit Focusing for Ultrasound Imaging", 2000 IEEE Ultrasonics Symposium, pp. 1215-1218.  
 Haun, Mark Alden, "New Approach to Aberration Correction in Medical Ultrasound Imaging", Ph.D. Thesis, University of Illinois at Urbana-Champaign, 2003, 134 pages.  
 Hergum, T., et al., "Parallel Beamforming using Synthetic Transmit Beams", 2004 IEEE International Ultrasonics, Ferroelectrics, and Frequency Control Joint 50th Anniversary Conference, pp. 1401-1404.  
 Jellins, J. et al., "Velocity compensation in water-coupled breast echography", *Ultrasonics*, Sep. 1973, pp. 223-226.  
 Liu, D., et al., "Adaptive Ultrasonic Imaging Using SONOLINE Elegra™", 2000 IEEE Ultrasonics Symposium, 4 pages.  
 Nock, L., et al., "Phase aberration correction in medical ultrasound using speckle brightness as a quality factor", *J. Acous. Soc. Am.*, May 1989, vol. 85, No. 5, pp. 1819-1833.  
 Robinson, B., et al., "Synthetic Dynamic Transmit Focus", 2000 IEEE Ultrasonics Symposium, pp. 1209-1214.  
 International Search Report and Written Opinion of Apr. 3, 2008 for PCT Application No. PCT/US07/81253, 9 pages.  
 Office Action of Nov. 5, 2010 for U.S. Appl. No. 12/628,169, 8 pages.  
 Office Action of Aug. 3, 2010 for U.S. Appl. No. 11/586,212, 8 pages.  
 Office Action of Jun. 24, 2010 for U.S. Appl. No. 11/492,471, 11 pages.  
 Office Action of Oct. 27, 2009 for U.S. Appl. No. 11/492,557, 14 pages.  
 Notice of Allowance of May 15, 2009 for U.S. Appl. No. 10/961,709, 8 pages.  
 Office Action of Feb. 3, 2009 for U.S. Appl. No. 11/492,557, 15 pages.  
 Office Action of Dec. 2, 2008 for U.S. Appl. No. 10/961,709, 4 pages.  
 Office Action of Sep. 14, 2007 for U.S. Appl. No. 10/961,709, 6 pages.  
 Nitzpon, P., et al., "New Pulsed Wave Doppler Ultrasound System to Measure Blood Velocities Beyond the Nyquist Limit," 1995, *IEEE Transactions Ultrasonics and Ferroelectrics, and Frequency Control*, vol. 42, No. 2, pp. 265-279.  
 Tortoli, P., et al., "Velocity Profile Reconstruction Using Ultrafast Spectral Analysis of Doppler Ultrasound," *IEEE Transactions Sonics and Ultrasonics*, vol. SU-32, No. 2, pp. 555-561, 1985.

\* cited by examiner

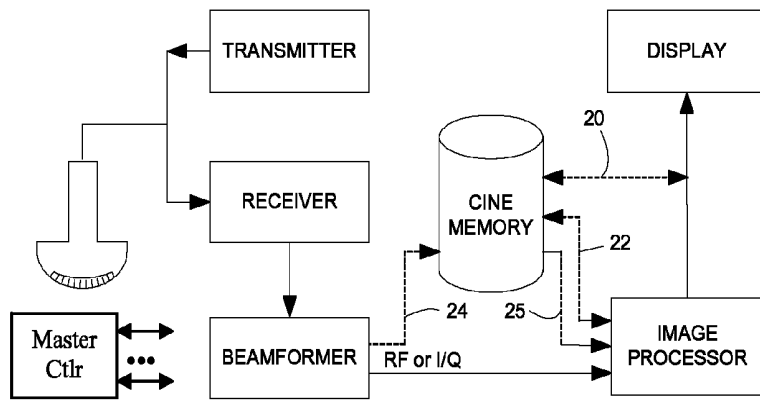

FIG. 1 (Prior Art)

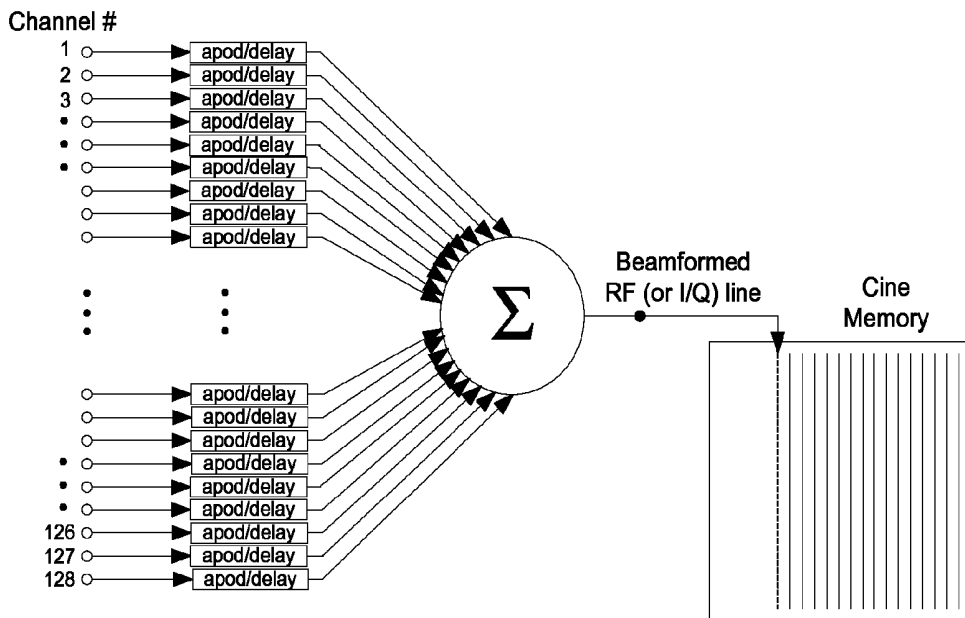

FIG. 2 (Prior Art)

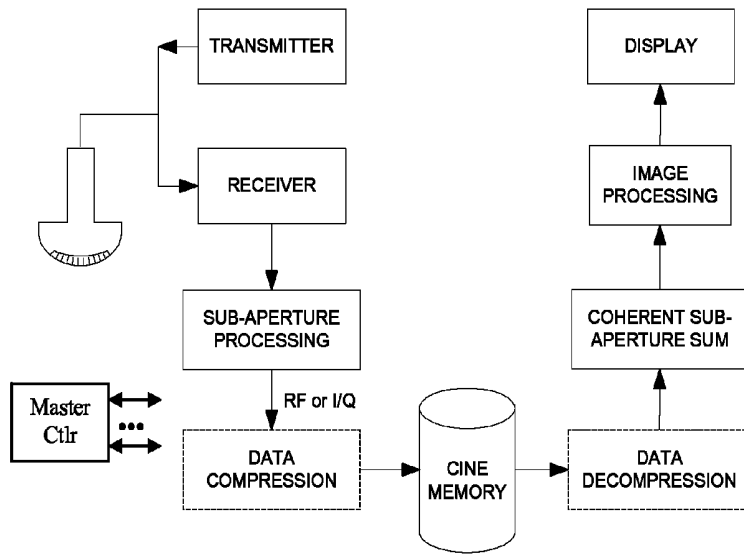

FIG. 3

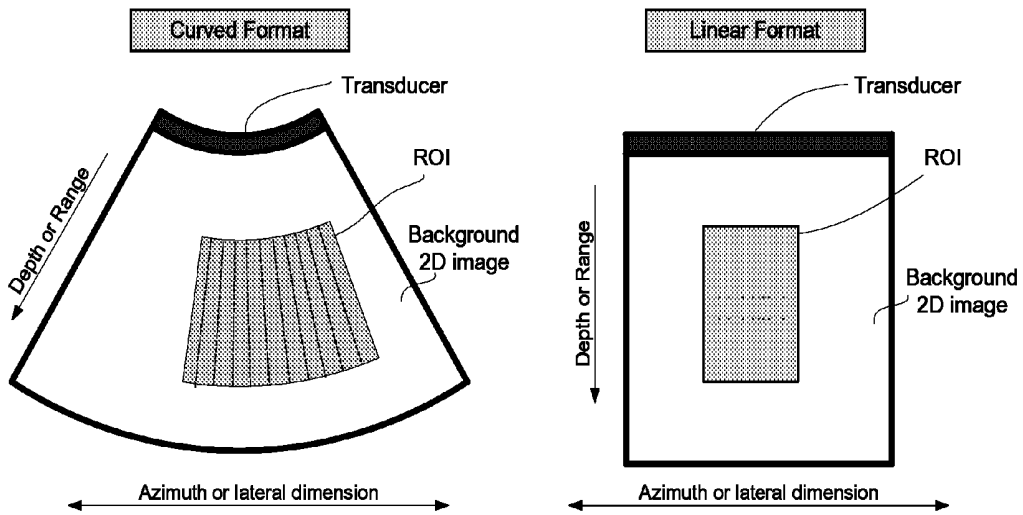

FIG. 4

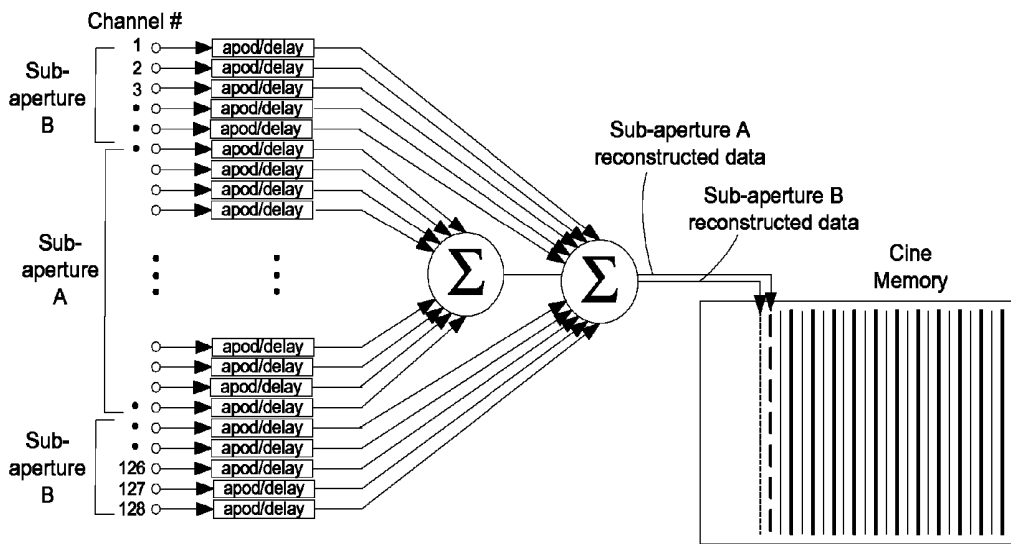

FIG. 5

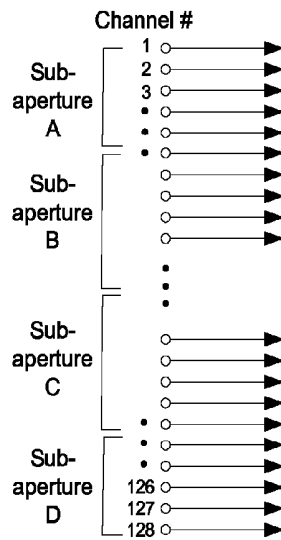

FIG. 6

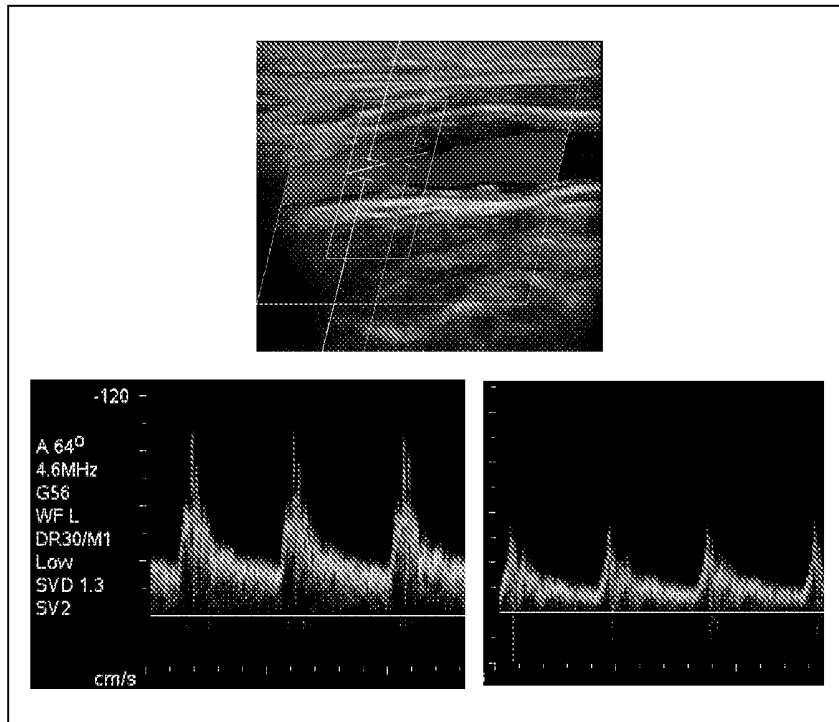

FIG. 7

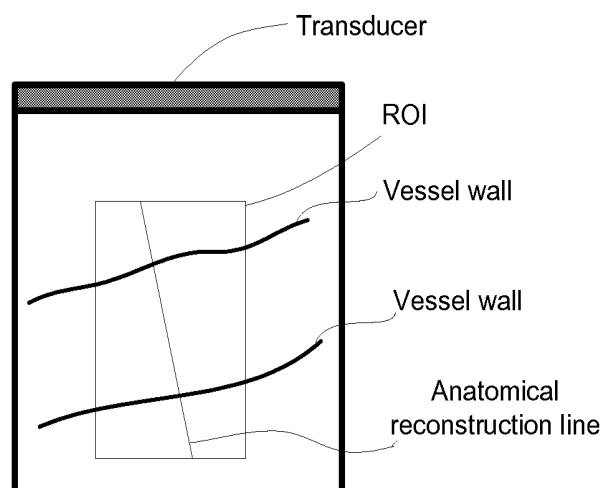
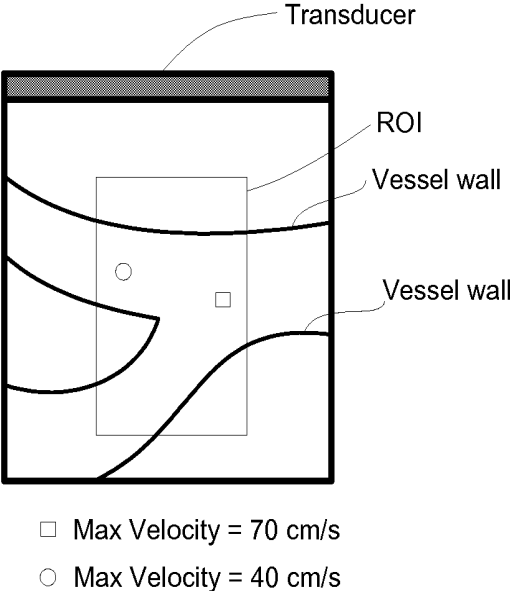

FIG. 8



**FIG. 9**

## SYSTEM AND METHOD FOR PROVIDING VARIABLE ULTRASOUND ARRAY PROCESSING IN A POST-STORAGE MODE

### CROSS-REFERENCE TO RELATED APPLICATIONS

This application claims the benefit of U.S. Patent Application No. 61/015,632 filed Dec. 20, 2008 for "System and Method for Providing Variable Ultrasound Array Processing in a Post-Storage Mode" (inventors Larry Y. L. Mo, Glen W. McLaughlin, Brian Derek DeBusschere, Ting-Lan Ji, Albert Gee, David J. Napolitano, Ching-Hua Chou, and Robert W. Steins) the entire disclosure of which is herein incorporated by reference for all purposes.

### BACKGROUND OF THE INVENTION

The present invention relates generally to ultrasound imaging, and more specifically to imaging techniques in a post-storage mode.

The following references are incorporated by reference:

U.S. Pat. No. 4,265,126: Papadofrangakis et al. (1981) "Measurement of true blood velocity by an ultrasound system."

U.S. Pat. No. 4,604,697: Luthra et al. (1986) "Body imaging using vectorial addition of acoustic reflection to achieve effect of scanning beam continuously focused in range."

U.S. Pat. No. 5,365,929: Peterson (1994) "Multiple sample volume spectral Doppler."

U.S. Pat. No. 5,409,010: Beach et al. (1995) "Vector Doppler medical devices for velocity studies."

U.S. Pat. No. 5,415,173: Miwa et al. (1995) "Ultrasound diagnosis system."

U.S. Pat. No. 5,690,111: Tsujino (1995) "Ultrasound diagnostic apparatus."

U.S. Pat. No. 6,221,020: Lysyansky et al. (2001) "System and method for providing variable ultrasound analyses in a post-storage mode."

U.S. Pat. No. 6,263,094: Rosich et al. (2001) "Acoustic data acquisition/playback system and method."

U.S. Pat. No. 6,450,959: Mo et al. (2002) "Ultrasound B-mode and Doppler flow imaging."

U.S. Pat. No. 6,679,847: Robinson et al. (2004) "Synthetically focused ultrasonic diagnostic imaging system for tissue and flow imaging."

U.S. Pat. No. 6,860,854: Robinson et al. (2005) "Synthetically focused ultrasonic diagnostic imaging system for tissue and flow imaging."

U.S. Pat. No. 6,926,671: Azuma et al. (2005) "Ultrasonic imaging apparatus and method."

U.S. patent application Ser. No. 11/492,471, filed Jul. 24, 2006: Napolitano et al. "Continuous Transmit Focusing Method And Apparatus For Ultrasound Imaging System."

Tortoli et al. (1985) "Velocity profile reconstruction using ultrafast spectral analysis of Doppler ultrasound." *IEEE Transactions Sonics and Ultrasonics*, vol. SU-32, pp. 555-561.

Nitzpon et al (1995) "New pulsed wave Doppler u/s system to measure blood velocities beyond the Nyquist limit." *IEEE Transactions Ultrason., Ferroelec. and Freq. Cntrl.*, vol. UFFC-42, pp. 265-279.

In ultrasonic B-mode imaging, a two-dimensional (2D) image of tissue is created in which the echo intensity is mapped to pixel brightness. For continuous wave (CW) measurement of blood flow in the heart and vessels, the frequency shifts of backscattered ultrasound waves are used to estimate blood velocities. For pulsed wave (PW) measurement of

blood flow, the phase shifts of backscattered ultrasound waves from a number of transmit excitations are used for flow estimation. In 2D color flow imaging and timeline color-M mode, the mean phase shift, which is proportional to the motion-induced Doppler frequency shift, is displayed using different colors that represent different flow speed. In spectral Doppler mode, the power spectrum of Doppler signals are computed and displayed as velocity-time waveforms. Contrast agents may be employed with any of the imaging modes to further enhance the signal-to-noise or signal-to-clutter ratio.

A typical ultrasound imaging system will include the following main subsystems: a transmitter, a receiver, a receive focusing unit, a cine memory buffer, an image processor/display controller, a display unit, and a master controller.

FIG. 1 is a block diagram of a conventional ultrasound system for which the receive array focusing unit is referred to as a beamformer, and image formation is performed on a scan-line-by-scan-line basis. System control is centered in the master controller, which accepts operator inputs through an operator interface and in turn controls the various subsystems. For each scan line, the transmitter generates a radio-frequency (RF) excitation voltage pulse waveform and applies it with appropriate timing across the transmit aperture (defined by a sub-array of active elements) to generate a focused acoustic beam along the scan line. RF echoes received by the receive aperture of the transducer are amplified and filtered by the receiver, and then fed into the beamformer, whose function is to perform dynamic receive focusing; i.e., to re-align the RF signals that originate from the same locations along various scan lines.

To reduce the data sampling rate requirements, the RF data is often converted (not shown) into baseband I/Q data before or after the beamformer. In the ZONARE Z.one™ system, a synthetic array focusing approach such as shown in U.S. patent application Ser. No. 11/492,471, filed Jul. 24, 2006 for "Continuous Transmit Focusing Method And Apparatus For Ultrasound Imaging System" (David J. Napolitano et al.) is used for 2D imaging. Specifically, a complete set of echo data obtained from a sequence of transmit-receive cycles is accumulated in digital memory first, and then combined coherently in the receive focusing unit to produce the effect of having continuously focused transmit and receive beams throughout the image field. Other methods of synthetic focusing have also been described in U.S. Pat. Nos. 4,604,697, 6,679,847, and 6,860,854, for both B-mode and flow imaging.

The image processor performs the processing specific to the active imaging mode(s) including 2D scan conversion that transforms the image data from an acoustic line grid to an X-Y pixel image for display. For Spectral Doppler mode, the image processor performs wall-filtering followed by spectral analysis of Doppler-shifted signal samples using typically a sliding FFT-window. It is also responsible for generating the stereo audio signal output corresponding to forward and reverse flow signals. In cooperation with the master controller, the image processor also formats images from two or more active imaging modes, including display annotation, graphics overlays and replay of cine loops and recorded timeline data.

The cine buffer provides resident digital image storage for single image or multiple image loop review, and acts as a buffer for transfer of images to digital archival devices. On most systems, the video images at the end of the data processing path can be stored to the cine memory. In state-of-the-art systems, amplitude-detected, beamformed data may also be stored in cine memory. For spectral Doppler, some

machines store the wall-filtered, baseband Doppler I/Q data for the user-selected range gate in cine memory, and the ZONARE z.one system stores the pre-wall-filtered data.

U.S. Pat. No. 6,263,094 describes a system wherein raw or partially processed data acquired early in the pipeline (pre-beamformed, post-beamformed, pre-video, etc.) is stored in non-volatile memory, and can be introduced into a signal processing system from memory at least at the rate that it was acquired, to produce a real time image that can be modified by the reviewer by further processing, if desired. The strict requirement of introducing the acoustic data at least at that particular rate is to ensure the real time playback is "as if the insonified target was the source of the acoustic data, not a storage device." [4:30-31].

For motion imaging, the cost of storing Doppler data from earlier points in the receive data path is greater cine memory capacity (or shorter image loops for the same memory size) and increased post-storage processing load (and response time). The benefits are encapsulated by the concept of a "virtual patient;" i.e., the sonographer can focus on setting the probe over the region of interest, and storing the raw (i.e., unprocessed) Doppler data first. Then, during cine review, the operator can take time to re-adjust the image processing parameters based on the same data set (the "virtual patient") without keeping the patient around longer than needed. Considering the fact that sonographers need to manage many front-panel system controls with one hand, hold the probe with the other hand, and deal with the patient's body movements, the workflow and ergonomic advantages of such post-storage data processing capabilities are clear.

U.S. Pat. No. 6,221,020 describes a system wherein beamformed (I/Q or RF) data from a region of interest is accumulated in cine memory during a storage period. As illustrated in FIG. 2, the receive beamforming refers to a weighted delay-and-sum operation, and the amplitude weighting across receive aperture is referred to as "apodization," which is important for suppressing the sidelobes of the receive beam profile. This method enables, during post-storage playback operation, any known signal processing and system control which have conventionally been carried out in real-time during the scanning session. For example, in a playback mode, the user may select any scan line and Doppler gate location and width within the region of interest for spectral Doppler or for color M-mode analysis. However, a limitation of this prior art is that the post-storage processing capabilities are restricted to conventional methods based on ultrasound data that is already beamformed.

Due to patient-to-patient variations and different anatomical scenarios in different clinical applications, a number of important system controls actually need to be effected before or during the beamforming process. For example, it is well known that the sound speed parameter used for array focusing operations can vary with different organ types and from patient to patient. Any sound speed optimization must be performed during the receive array focusing or reconstruction process. In particular, the ZONARE z.one system supports channel domain processing that first stores all the raw transducer element data in a channel domain memory, and then allows digital signal processor units to access the channel data multiple times in order to support an iterative algorithm that optimizes the array focusing sound speed. It is important to note that this kind of adaptive processing may take up to a few seconds to complete while the rest of the signal pipeline is paused; i.e., the channel data is often read out by the signal processors multiple times and at a rate that may be lower than when it was acquired.

In spectral Doppler mode, the receive aperture, which determines the receive F-number (defined by the ratio of focal range to aperture size), directly controls the degree of receive focusing. A lower F-number means stronger focusing or a tighter beam width. For small vessels or weak signals from deep lying vessels, it is advantageous to maximize the receive aperture size for best sensitivity/penetration. On the other hand, it is well known that because different elements of the active aperture form different angles with the flow direction, a large aperture (low F-number) can give rise to an increased velocity over-estimation errors—an effect referred to as geometrical spectral broadening.

U.S. Pat. No. 6,679,847 describes the synthetic focus system that stores raw channel data and applies different beamforming delay curves to track blood motion. This invention is also aimed at providing flexible motion analyses and display methods, but it is fundamentally a pure synthetic focus system that utilizes single or small groups of elements for transmit (with known sensitivity challenges associated with limited acoustic power outputs) and requires an entire set of uncombined channel data to be stored for each image frame.

#### SUMMARY OF THE INVENTION

There is a need for a more flexible system that can store data that is not fully beamformed, and can introduce the stored data into a signal processing unit at a suitable rate that is not bound by the acquisition data rate, to provide variable Doppler array focusing adjustments and image processing in a post-storage mode.

The present invention pertains to novel imaging capabilities in a post-storage mode, and is typically incorporated in an ultrasound imaging system that includes the following main subsystems: a transmitter, a receiver, a receive focusing unit, a cine memory buffer, an image processor/display controller, a display unit and a master controller.

Embodiments of the present invention provide a system and method for accumulating partially reconstructed echo data from a region of interest during a storage period. The selection of the region of interest may be effected via standard user interface control mechanisms (e.g. trackball and "set" buttons), based on a real-time background B-mode and/or color flow image display. The accumulated echo data representing the region of interest is then processed during a post-storage operation to provide a number of user-selectable and/or adaptive array focusing strategies, motion analysis and display modes. The system further comprises front-panel controls that enable the user to select not only which retrospective processing method to be used, but also one or more spatial locations within the region of interest for such processing.

The techniques for accumulating partially reconstructed echo data from a region of interest during the storage period (where results are stored for subsequent processing in the post-storage phase) represent a commercially significant body of technology in their own right. Similarly, the techniques for retrieving and processing the partially reconstructed data during the post-storage period represent a commercially significant body of technology in their own right. Thus the two, which may be thought of as sub-combinations, should each be seen as a standalone aspect of the invention. While by definition accumulation and processing are done at different times, it is also contemplated that the two will often be done in different places by different entities.

In addition to the post-storage array focusing and image processing parameter adjustments, a number of advanced Doppler analysis and imaging methods can benefit from this

invention include Doppler spatial compounding for improved velocity estimation, dual-frequency Doppler for extended velocity range, dual timeline Doppler, multi-gate spectral flow imaging, strain-rate imaging and adaptive post-processing including adaptive clutter filtering and display parameters. These and other methods have been reported in various published papers and are well known to those skilled in the art.

Hence, the potential benefits of this invention include not just all of the virtual patient capabilities, but also being able to analyze and process the same Doppler data using alternate processing and display methods aimed at extracting more diagnostic information.

A further understanding of the nature and advantages of the present invention may be realized by reference to the remaining portions of the specification and the drawings.

#### BRIEF DESCRIPTION OF THE DRAWINGS

FIG. 1 is a block diagram of a conventional ultrasound system;

FIG. 2 is a block diagram showing prior art receive beamforming where a weighted delay-and-sum operation is performed;

FIG. 3 is a block diagram of a specific embodiment of the present invention;

FIG. 4 shows a preferred embodiment showing a motion imaging region of interest ("ROI") for a curved scan format (left portion of figure) and for a steered linear scan format (right portion of figure);

FIG. 5 shows a preferred embodiment in which the two receive sub-aperture channel sets are reconstructed and stored for each acoustic grid point;

FIG. 6 shows a preferred embodiment in which the receive channels are divided into four sub-aperture groups for processing and storage;

FIG. 7 shows a preferred embodiment in which the region of interest (smaller box) for which partially beamformed PW Doppler data is stored is a sub-region of the standard color flow region of interest (larger box), and also shows the timeline spectrograms for two Doppler sample volumes along separate PW Doppler lines being displayed side-by-side;

FIG. 8 shows an anatomical reconstruction line within the ROI; and

FIG. 9 shows multiple sample volumes for quantitative Doppler waveform analysis.

#### DESCRIPTION OF SPECIFIC EMBODIMENTS

FIG. 3 is a block diagram of a preferred embodiment of the present invention for which system control is centered in a master controller that accepts operator inputs through an operator interface and in turn controls the various major data processing subsystems. It is well known to those skilled in the art that, through an user interface, the operator can specify a region of interest ("ROI") for a motion imaging mode (e.g., spectral Doppler, color velocity and energy imaging, and Doppler tissue imaging) within a background B-mode image. It is also well known that depending on the transducer type (curvilinear, linear or sector), a corresponding scan format is used to generate both the B-mode and motion imaging ROI.

FIG. 4 shows the examples of a curved and a linear array PW scan format, wherein the 2D motion imaging ROI defines a 2D acoustic grid for array focusing or reconstruction operations. If the reconstruction is achieved using a conventional beamforming method, the acoustic grid comprises a set of scan lines as illustrated for the case of the curvilinear scan.

With ZONARE's imaging approach (see U.S. patent application Ser. No. 11/492,471), the received data from all receive channels and transmit events are first accumulated into a channel domain memory unit (not shown), such that the array focusing can follow an arbitrary acoustic grid as illustrated for the case of the linear scan (notice the lateral and/or axial spacing do not even need to be uniform). In general, the transmit-receive array focusing and steering strategies including the acoustic reconstruction grid are independent of those that constitute the background 2D image.

In general, this invention can be extended to 3D imaging such that the ROI refers to a 3D volume in space. That is, the ROI is not restricted to a 2D plane as shown in FIG. 4. For CW Doppler imaging, the ROI would theoretically extend from the surface of the probe to infinite depth.

#### Transmitter and Receiver

The main functions of the transmitter and receiver in FIG. 3 are to acquire a set of echo data from the ROI over a sufficiently long time interval such that motion effects can be measured. For both CW and PW imaging modes, the ROI can be divided into one or more transmit scan directions, and it is well known that the overall lateral spatial resolution is determined by the product of the transmit and receive array focusing response at each location.

In PW modes, a number of repeated transmit-receive events at a user-selectable pulse repetition frequency (PRF) is used to interrogate moving sound reflectors along each transmit scan direction. That is, for each spatial location within the ROI, a packet of echo data samples from the repeated transmit-receive events is available for analysis. The number of data samples per packet is referred to as a "packet size." For each packet, motion-induced echo changes from one sample to the next can be detected. A motion estimate (e.g., mean velocity) can be derived for each spatial location within the ROI, and the results can be translated into a 2D image, usually via a color mapping.

Suppose the ROI consists of 10 scan directions and suppose the packet size is 12. This means that for each image frame,  $10 \times 12 = 120$  transmit-receive events are needed. In order to maximize the data acquisition time, various well known acquisition strategies may be used including multi-line and broad beam acquisition (one transmit broad beam spans two or more lateral positions in the acoustic reconstruction grid) and transmit interleaving (when the PRF is sufficient low such as for deep imaging, a transmit pulse may be fired along a different scan direction before the echo from the previous firing returns). Typically, the RF echoes received by the receive aperture of the transducer are amplified and filtered by the receiver.

To enhance the axial resolution of the transmit pulse, and/or improve penetration, coded excitation methods may be used wherein the transmit encoder (not shown) repeats a transmit pulse multiple times according to a signal modulation or coding scheme and a receive decoder (not shown) compresses the received signal thereby restores the uncoded pulse resolution but with greater signal to noise ratio. It is well known to those skilled in the art that the receive decoding can be implemented before or after receive array focusing.

To reduce the data sampling rate requirements, the RF echo data is often converted (not shown) into baseband I/Q data before or after receive beamforming or array focusing. Optionally, as in the ZONARE z.one system, the received data from all receive channels and transmit events can be accumulated into a channel domain memory unit first prior to sub-aperture processing. Throughout this document, the term "image reconstruction" will be used in relation to the preferred embodiments of the present invention, as the channel

domain processing involved is different and more general than conventional beamforming.

#### Sub-Aperture Processing

In contrast to the prior art of FIG. 2, an important aspect of the present invention lies with the sub-aperture processing of the received echo data from the different elements of the receive aperture. A sub-aperture refers to any subset (i.e., not necessarily contiguous) of the transducer elements that comprise the full receive aperture. For example, a sub-aperture may be defined by alternating elements across the physical array, or by alternating groups of 2 or more elements. The partially focused sub-aperture data sets are then stored in the cine memory such that during a post-storage period, the user can process and re-process the stored data with new degrees of flexibility not available with conventional systems. "Subset" in this context means at least one transducer element and fewer than all the transducer elements.

As illustrated by FIG. 5, one preferred embodiment is to divide the receive aperture into two groups: an inner sub-aperture group (A) and an outer sub-aperture group (B). Each group is combined taking into account of time delay, phase and amplitude weighting for optimal receive focusing. During post-storage processing, the receive aperture can effectively be adjusted by applying different weightings to the inner and outer sub-aperture. For flow imaging, this provides a means for the user to adjust the tradeoff between flow sensitivity and geometrical spectral broadening error.

In another preferred embodiment as shown in FIG. 6, the receive channels are grouped into a set of N contiguous sets of receive aperture elements. For example, suppose there are N=4 channels groups of different aperture sizes. For each acoustic grid point, 4 groups of partial reconstruction (apodized coherent sums) will be stored. A coarse sound speed tuning can be realized by adjusting the relative time delays of the different sub-aperture groups during post-storage processing. That is, each sub-aperture group is regarded as a single receiver whose time delay is given by twice the distance between the center of the sub-aperture to the desired focus location, divided by an assumed sound speed value. This process can also be automated by implementing an iterative algorithm in the image processor that combines (with appropriate time delays) the sub-aperture data set multiple times using a range of trial sound speed values, and automatically selects the best sound speed that yields the best focusing in terms of a pre-determined metric (e.g., signal energy within the focus region).

As disclosed separately in U.S. patent application Ser. No. 11/492,471, reconstruction (sub-aperture reconstruction in the present case) is not limited to receive array focusing, but may incorporate synthetic transmit array focusing, especially for slow flow conditions. That is, improvements in transmit array focusing can be achieved retrospectively by coherently combining channel data acquired from different transmit events.

#### Data Compression and Storage

Referring to FIG. 3, after the sub-aperture processing, the partially focused sub-aperture echo data can be optionally compressed via a suitable encoding method to reduce the total amount of data for cine memory storage. During cine playback or post-storage processing, the compressed data is first decoded or un-compressed prior to further processing. Since ultrasound echo data is correlated across channels, across range, and across spatially adjacent transmit firings, and in addition, in applications of color flow and spectral Doppler, the same reconstruction line is repeatedly sampled, there is a lot of redundant information present in raw echo data such that the opportunity for compression is great. Many encoding/

decoding techniques, both lossless and lossy, can be used including simple decimation, linear predictive coding, discrete cosine transform, and wavelet transform. Some of these methods treat the data as a sequence of one's and zero's.

In a preferred embodiment of the present invention, the cine data is stored in non-volatile media on the system. In another preferred embodiment, the cine data, with or without compression, can be transferred to a remote workstation for post-processing and review. The data communications network connection to the remote review station can be a wireless network.

#### Preferred Embodiments of Post-Storage Variable Array Processing and Imaging Modes

One preferred embodiment of the present invention pertains to post-storage CW Doppler imaging capabilities. A single transmit broad beam is used to define a relatively narrow ROI that may comprise two or more reconstruction lines as defined by receive array focusing. Since only one transmit beam is needed to scan the entire ROI, a CW transmit beam can be used, and partially focused sub-aperture receive channel groups of sampled I/Q data are stored in the cine memory. As an example, for a CW transmit frequency of  $f_0=5$  MHz, if the highest blood velocity to be measured is  $v=10$  m/s (e.g., in cardiac scans), the corresponding maximum Doppler frequency shift is  $2(v/c)=64.9$  kHz for  $c=1540$  m/s (sound speed in blood). Hence, to avoid aliasing the I/Q data may be sampled at 100 kHz. During cine playback, the user can select via front-panel control of the system a specific CW Doppler line within the ROI for spectral analysis. In effect, the CW Doppler line can be adjusted retrospectively after the raw data is acquired. Further, depending on which sub-aperture grouping method is used (FIG. 5 and FIG. 6), this invention also enables post-storage user-adjustments of receive aperture (geometrical spectral broadening errors) and receive aperture focusing sound speed.

In another preferred embodiment of the present invention, a post-storage PW Doppler mode wherein the sample gate position and/or receive aperture size can be retrospectively adjusted upon cine playback. One or more transmit beams are used to define a ROI within which a specific sample gate can be selected retrospectively for spectral analysis. If the PRF is sufficiently low, two or more PW transmit-receive cycles can be interleaved; i.e., the PW transmit pulse for an adjacent beam can be fired while waiting for the echo to return from the previous firing. If the PRF is too high for interleaving, a single and broader transmit beam may be used such that it covers the entire ROI. The received channel data for each transmit firing are grouped according to the inner and outer sub-aperture scheme of FIG. 5, with each group combined to form two or more reconstruction lines that span the ROI, and then stored in cine memory. Upon cine playback, any sample gate along any reconstruction line within the ROI can be selected via front-panel controls for spectral Doppler analysis as in live PW spectral Doppler imaging. One exemplary application is, as shown in FIG. 7, is to enable comparative and/or simultaneous blood flow analysis at two different locations relative to a stenosis in an artery. Two independent sample gates along two different reconstruction lines can be selected for spectral analysis, and the resultant time-line spectral waveforms can be displayed as a dual-image below the 2D color flow reference image. Regardless of the post-processing and display method, the receive aperture size for a selected PW Doppler line can be adjusted by applying different weight factors to the partially focused inner and outer sub-aperture echo data.

In another preferred embodiment, one or more transmit PW broad beams are used to define the ROI. The received channel data for all transmit events are accumulated in a

channel domain memory. With access to the channel data memory, programmable processors (e.g., DSP chips, FPGA) are employed to perform the sub-aperture reconstruction, which is no longer constrained to follow a set of scan lines as in a conventional hardware-based beamformer. As illustrated in FIG. 8, the reconstruction follows an “anatomical line” that can be specified via front-panel user-controls to be substantially normal to the near and far walls of a vessel of interest, instead of a conventional scan line that is parallel to the transmit-receive beam. In general, an anatomical reconstruction line is chosen to follow the geometry of the anatomy of interest (e.g., vessel cross-section) instead of a transmit-receive beam pattern. During cine playback, the user can select any arbitrary sample gate along the anatomical reconstruction line for detailed spectral analysis. Alternatively, a plurality of sample gates along a selected anatomical line can be processed in parallel to produce a dynamic spectral flow profile of range versus velocity, as taught by Tortoli et al. (1985), and also taught in U.S. Pat. No. 6,450,959.

As an extension to the preferred embodiments of FIG. 7 and FIG. 8, the user can select two or more sample volumes in arbitrary positions within the ROI for quantitative spectral Doppler waveform index calculations during a post-storage period. Shown in FIG. 9 is an example in which a bifurcating artery is being studied by placing a sample volume in the common vessel and one in a branch vessel. The time-line spectral Doppler waveforms corresponding to the two sample volumes can be optionally displayed as a dual image below the 2D image (as in FIG. 7). An automated maximum envelope or mean velocity waveform tracing algorithm is implemented to track various spectral waveform indices such as maximum velocity (over a cardiac cycle) and the systolic to diastolic ratio. In FIG. 9, the maximum velocities for the two sample volumes are displayed below the 2D image.

Another preferred embodiment of the present invention is retrospective 2D color flow or tissue motion imaging. The acquisition strategies and options are similar to the aforementioned PW Doppler modes, except the display is in the form of a colorized flow image or a 2D grid of sample gates within the ROI. A packet of say, 10 transmit-receive events is acquired for each motion image frame, and another packet for the next frame etc. For each image frame, a 2D grid of sample gates is analyzed serially or in parallel to estimate motion parameters such as mean velocity and motion signal energy. The processing may include a motion-discrimination filtering step including a high-pass “clutter” filter for flow imaging, and a low-pass “flow-signal” filter for tissue motion imaging. The results are displayed using a pre-determined color map to provide a visual representation of the spatial distribution of the flow parameters within the ROI.

Another preferred embodiment of the present invention involves use of two or more independent sets of reconstruction lines that intersect each other within the ROI. It is well known to those skilled in the art that sub-aperture data obtained from two or more independent views of a sample volume can be combined to estimate the velocity vector (magnitude and direction) and/or to reduce estimation variance. By storing the sub-aperture data sets corresponding to different reconstruction lines in cine memory, the improved velocity estimation can be effected in a post-storage mode.

Other advanced Doppler analysis and imaging methods that can benefit from the present invention include dual-frequency Doppler for extended unambiguous velocity measurement range, and adaptive post-processing including adaptive receive aperture, range-gating, PRF re-sampling, and display parameters. For example, using the inner and outer sub-aperture method of FIG. 5, an adaptive receive

aperture can be realized by prescribing weight factors for the two sub-aperture groups based on an estimate of the motion signal parameter (e.g., signal energy, mean or maximum Doppler frequency). If the flow signal is strong, the weighting on the outer sub-aperture group may be reduced relative to the inner sub-aperture group thereby reduce geometrical spectral broadening errors.

In the foregoing specification the invention has been described with reference to specific exemplary embodiments. It will, however, be evident that various modifications and changes can be made without departing from the broader spirit and scope of the invention as set forth in the appended claims. The specification and drawings are, accordingly, to be regarded in an illustrative rather than restrictive sense.

The invention claimed is:

1. A method of analyzing movement of blood or anatomical structures or both within a region of interest, operating in conjunction with B-mode or color flow imaging modes or both, the method comprising:

activating a transmit aperture within a multi-element transducer array;

transmitting one or more ultrasonic beams along one or more scan directions that span the region of interest;

for each transmit event, receiving ultrasound echoes from each element of a receive aperture;

grouping the receive channel echo data into two or more sets corresponding to a first set of receive sub-apertures; combining each sub-aperture data set to generate partially focused echo-location data for one or more reconstruction lines;

storing all the sub-aperture echo data sets during a storage period in a format that can be retrieved for later analysis, such that the stored, partially focused echo data sets are capable of being recombined according to a second, different set of receive sub-apertures; and determining a sound speed value by iteratively focusing data of two or more receive sub-apertures under different respective trial sound speed values.

2. The method of claim 1, and further comprising:

during a post-storage period, retrieving stored sub-aperture data at a rate that is not bound by the rate at which the sub-aperture data was acquired; and

combining the sub-aperture data to form one or more selected reconstruction lines;

processing echo data to extract motion information from one or more sample positions along the selected reconstruction lines; and

displaying an image representative of the processed motion information.

3. The method of claim 2, and further comprising:

selecting, in response to user signals, one or more spatial locations within the region of interest for retrospective processing during the post-storage period;

adjusting, in response to user signals, the post-storage receive array focusing and motion-analysis modes and associated processing parameters.

4. The method of claim 1 wherein transmitting one or more ultrasonic beams comprises generating a sequence of ultrasound pulses designed to adequately sample a moving target with a given maximum velocity in the direction of the transmit beam.

5. The method of claim 1 wherein transmitting one or more ultrasonic beams comprises generating a continuous acoustic wave of a pre-determined transmit frequency.

6. The method of claim 1 wherein transmitting one or more ultrasonic beams comprises generating a weakly focused or broad beam that spans two or more reconstruction lines.

## 11

7. The method of claim 1 wherein transmitting one or more ultrasonic beams comprises generating two or more ultrasound beams transmitting the beams such that they cross over each other within the region of interest.

8. The method of claim 1, and further comprising the step, performed prior to storing given sub-aperture echo data, of converting the received echo data from RF to baseband I/Q components.

9. The method of claim 1, further comprising accumulating and holding the received ultrasound echo data from each transducer element from one or more transmit events in a channel domain memory until said partial focusing operations for an entire image frame are completed.

10. The method of claim 1 wherein combining sub-aperture data set to generate partially focused echo-location data includes combining channel data obtained from two or more transmit events.

11. The method of claim 1, and further comprising the step, performed prior to storing a given sub-aperture echo data set, of compressing the given sub-aperture echo data set.

12. The method of claim 1 wherein grouping the receive channel echo data into two or more sets comprises dividing the receive aperture into two channel groups: a first group that represents an inner sub-aperture of the receive array, and a second group that comprises two outer sub-apertures.

13. The method of claim 1 wherein grouping the receive channel echo data into two or more sets comprises dividing the receive aperture into N contiguous groups of elements, where N is greater than or equal to two.

14. The method of claim 1 wherein combining sub-aperture data set to generate partially focused echo-location data for one or more reconstruction lines comprises constructing at least one reconstruction line that does not follow the direction of a transmit beam.

15. The method of claim 1, and further comprising the step, performed prior to storing a given sub-aperture group, of combining the given sub-aperture group with the appropriate time delays, phase shifts and amplitude weightings to form partially focused lines along one or more reconstruction lines.

16. The method of claim 1 wherein storing the partially focused sub-aperture echo data comprises storing the partially focused sub-aperture echo data in non-volatile media on the system or on a remote review station that is connected to the system via a digital communications network.

17. The method of claim 1, and further comprising, during a post-storage period, combining the sub-aperture data for the selected reconstruction line(s) with different amplitude weightings to control the overall receive aperture apodization function of the resultant reconstruction line(s).

18. The method of claim 1, wherein determining the sound speed value comprises selecting one of a plurality of trial sound speeds based on focus metrics of the two or more receive sub apertures under the respective trial sound speeds.

19. The method of claim 2, and further comprising prior to the sub-aperture data combining step, of performing some processing of the echo data for each sub-aperture.

20. The method of claim 1, and further comprising processing multiple sample gates along the same reconstruction line simultaneously to produce a spectral flow profile.

21. The method of claim 1, and further comprising processing different sample gates within the ROI in parallel.

22. The method of claim 21, and further comprising displaying time-line spectral waveforms corresponding to the different sample gates using multiple image display windows.

## 12

23. The method of claim 21, and further comprising: automatically computing Doppler spectral waveform indices over one or more cardiac cycles; and displaying the spectral waveform indices for two or more sample gates within the ROI.

24. The method of claim 1, and further comprising processing the corresponding sample gates defined by the region of intersection between two or more transmit-receive cross reconstruction lines such that echo data from the different views are combined to improve motion estimation including variance reduction and flow direction or Doppler angle estimation.

25. A system for analyzing movement of blood or anatomical structures or both within a region of interest, operating in conjunction with B-mode or color flow imaging modes or both, the system comprising:

a processing device; and

a storage device;

said processing device operating, during a storage period, to:

generate signals that result in activating a transmit aperture within a multi-element transducer array;

generate signals that result in instructing the transducer array to transmit one or more ultrasonic beams along one or more scan directions that span the region of interest;

for each transmit event, receiving data representing ultrasound echoes from each element of a receive aperture;

grouping the receive channel echo data into two or more sets corresponding to a first group of different receive sub-apertures;

combining each sub-aperture data set to generate partially focused echolocation data for one or more reconstruction lines;

storing all the sub-aperture echo data sets in said storage device in a format that can be retrieved for later analysis, such that the stored, partially focused echolocation data is configured to be recombined into a second group of different receive sub-apertures; and

determining a sound speed value by iteratively focusing data of two or more receive sub-apertures under different respective trial sound speeds.

26. A method of analyzing movement of blood or anatomical structures or both within a region of interest, the method comprising:

retrieving sub-aperture data generated during a previous storage period where the sub-aperture data represents partially focused echo-location data resulting from grouping receive channel echo data from elements of a receive aperture into different receive sub-apertures that follow a first set of scan lines;

determining a sound speed by selecting one of a plurality of trial sound speed values resulting in an optimal focus of one or more of the sub-apertures;

combining the sub-aperture data to form one or more selected reconstruction lines, wherein the selected reconstruction lines correspond to a second set of scan lines that differ from the first set of scan lines;

processing echo data to extract motion information from one or more sample positions along the selected reconstruction lines; and

displaying an image representative of the processed motion information.

27. The method of claim 26 wherein the sub-aperture data had been stored in a compressed format, and further comprising uncompressing the sub-aperture data prior to further processing during the post-storage period.

13

28. The method of claim 26, and further comprising after retrieving sub-aperture data, combining the sub-aperture data, combining the sub-aperture data from the selected reconstruction line(s) within different amplitude weightings to control the overall receive aperture apodization function of the resultant reconstruction line(s).

29. The method of claim 26, and further comprising after retrieving sub-aperture data, combining the sub-aperture data for the selected reconstruction line(s) with different time delays and phase shifts based on an assumed sound speed value.

30. A system for analyzing movement of blood or anatomical structures or both within a region of interest, operating in conjunction with B-mode or color flow imaging modes or both, the system comprising:

- a processing device; and
- a storage device;

said processing element operating, during a post-storage period, to:

access a storage device storing sub-aperture data generated during a previous storage period where the sub-aperture data represents partially focused echo location data resulting from grouping receive channel echo data from elements of a receive aperture into different receive sub-apertures that correspond to a first set of scan lines;

retrieve from said storage device stored sub-aperture data at a rate that is not bound by a rate at which the stored sub-aperture data was acquired;

determine a sound speed by selecting one of a plurality of trial sound speed values resulting in an optimal focus of one or more of the sub-apertures;

combine the sub-aperture data to form one or more selected reconstruction lines that correspond to a second set of scan lines different from the first set of scan lines;

process echo data to extract motion information from one or more sample positions along the selected reconstruction lines; and

14

generate signals that result in displaying an image representative of the processed motion information.

31. A method of analyzing movement of blood or anatomical structures or both within a region of interest, operating in conjunction with B-mode or color flow imaging modes or both, the method comprising:

activating a transmit aperture within a multi-element transducer array;

transmitting one or more ultrasonic beams along one or more scan directions that span the region of interest;

for each transmit event, receiving ultrasound echoes from each element of a receive aperture;

grouping the receive channel echo data into two or more sets corresponding to a first set of different receive sub-apertures;

combining each sub-aperture data set to generate partially focused echo-location data for one or more reconstruction lines;

storing all the sub-aperture echo data sets during a storage period, such that the stored, partially focused echo location data sets are capable of being recombined according to one or more different sets of different receive sub-apertures;

combining the sub-aperture data to form a second set of receive sub-apertures corresponding to one or more selected reconstruction lines during a post-storage period;

determining a sound speed value corresponding to the stored sub-aperture echo data sets by iteratively focusing the first set of sub-apertures under different trial speed values and selecting the trial speed value that yields an optimal focusing result;

processing echo data to extract motion information from one or more sample positions along the selected reconstruction lines; and

displaying an image representative of the processed motion information.

\* \* \* \* \*

专利名称(译)	用于在后存储模式下提供可变超声阵列处理的系统和方法		
公开(公告)号	<a href="#">US9060669</a>	公开(公告)日	2015-06-23
申请号	US12/340578	申请日	2008-12-19
[标]申请(专利权)人(译)	MO LARRY 莫大号 MCLAUGHLIN GLEN W debusschere 德里克布赖恩 姬廷局域网 GEE ALBERT NAPOLITANO DAVID J 周清华 STEINS ROBERT W		
申请(专利权)人(译)	MO, LARRY Y. L. MCLAUGHLIN, GLEN W. 德布斯切尔, BRIAN DEREK JI, 寿-LAN GEE, ALBERT 纳波利塔诺, DAVID J. CHOU, 李庆华 杯, ROBERT W.		
当前申请(专利权)人(译)	ZONARE 医疗系统, INC.		
[标]发明人	MO LARRY Y L MCLAUGHLIN GLEN W DEBUSSCHERE BRIAN DEREK JI TING LAN GEE ALBERT NAPOLITANO DAVID J CHOU CHING HUA STEINS ROBERT W		
发明人	MO, LARRY Y. L. MCLAUGHLIN, GLEN W. DEBUSSCHERE, BRIAN DEREK JI, TING-LAN GEE, ALBERT NAPOLITANO, DAVID J. CHOU, CHING-HUA STEINS, ROBERT W.		
IPC分类号	A61B8/00		
CPC分类号	A61B8/4488 A61B8/00 A61B8/565 A61B8/08 A61B8/0891 A61B8/14 A61B8/4483 A61B8/463 A61B8/488 A61B8/5207 A61B8/5223 A61B8/54 G01S7/52034 G01S7/52049 G01S15/8927 G01S15/8979		
代理人(译)	克里斯滕森 KORY D.		
审查员(译)	LUONG, PETER		
优先权	61/015632 2007-12-20 US		
外部链接	<a href="#">Espacenet</a> <a href="#">USPTO</a>		

### 摘要(译)

超声成像方法包括激活多元件换能器阵列内的发射孔径，沿着跨越感兴趣区域的扫描方向发射一个或多个超声波束，用于每个发射事件，从接收器的每个元件接收超声回波孔径，将接收信道回波数据分组为对应于不同接收子孔径的两个或更多个组，组合每个子孔径数据组以产生用于一个或多个重建线的部分聚焦的回波位置数据，并存储所有子孔径在存储期间可以检索以供以后分析的格式回显数据集。一种方法包括：在存储后时段期间，检索存储的子孔径数据，组合子孔径数据以形成一个或多个选定的重建线，处理回波数据以沿着所选择的重建从一个或多个样本位置提取运动信息。线条，并显示代表处理过的运动信息的图像。

