



US006962567B2

(12) **United States Patent**  
**Eberle et al.**

(10) **Patent No.:** **US 6,962,567 B2**  
(45) **Date of Patent:** **\*Nov. 8, 2005**

(54) **ULTRASOUND TRANSDUCER ASSEMBLY**

(75) Inventors: **Michael J. Eberle**, Fair Oaks, CA (US); **Gary P. Rizzuti**, Shingle Springs, CA (US); **Horst F. Kiepen**, Georgetown, CA (US)

(73) Assignee: **Volcano Therapeutics, Inc.**, Laguna Hills, CA (US)

(\* ) Notice: Subject to any disclaimer, the term of this patent is extended or adjusted under 35 U.S.C. 154(b) by 0 days.

This patent is subject to a terminal disclaimer.

(21) Appl. No.: **09/906,302**

(22) Filed: **Jul. 16, 2001**

(65) **Prior Publication Data**

US 2001/0041842 A1 Nov. 15, 2001

**Related U.S. Application Data**

(63) Continuation of application No. 09/658,323, filed on Sep. 8, 2000, now Pat. No. 6,283,920, which is a continuation of application No. 09/324,692, filed on Jun. 2, 1999, now Pat. No. 6,123,673, which is a continuation of application No. 08/935,930, filed on Sep. 23, 1997, now Pat. No. 5,938,615, which is a division of application No. 08/712,166, filed on Sep. 11, 1996, now Pat. No. 5,779,644, which is a continuation of application No. 08/516,538, filed on Aug. 18, 1995, now Pat. No. 5,603,327, which is a continuation of application No. 08/234,848, filed on Apr. 28, 1994, now Pat. No. 5,453,575, which is a continuation-in-part of application No. 08/012,251, filed on Feb. 1, 1993, now Pat. No. 5,368,037.

(51) **Int. Cl.**<sup>7</sup> ..... **A61B 8/12**

(52) **U.S. Cl.** ..... **600/466; 29/25.35**

(58) **Field of Search** ..... **600/437, 439, 600/459-471; 29/25.35**

(56) **References Cited**

**U.S. PATENT DOCUMENTS**

|             |         |                 |
|-------------|---------|-----------------|
| 3,605,723 A | 9/1971  | King et al.     |
| 3,827,115 A | 8/1974  | Bom             |
| 3,938,502 A | 2/1976  | Bom             |
| 4,191,193 A | 3/1980  | Seo             |
| 4,211,949 A | 7/1980  | Brisken et al.  |
| 4,237,900 A | 12/1980 | Schulman et al. |
| 4,274,423 A | 6/1981  | Mizuno et al.   |
| 4,325,257 A | 4/1982  | Kino et al.     |
| 4,456,013 A | 6/1984  | De Rossi et al. |

(Continued)

**FOREIGN PATENT DOCUMENTS**

|    |           |         |
|----|-----------|---------|
| EP | 0145429   | 6/1985  |
| EP | 0346891 A | 12/1989 |

(Continued)

**OTHER PUBLICATIONS**

Bom, N. et al., "Early and Recent Intraluminal Ultrasound Devices," *International Journal of Cardiac Imaging*, vol. 4, pp. 79-88, (1989).

(Continued)

*Primary Examiner*—Francis J. Jaworski

(74) *Attorney, Agent, or Firm*—Leydig, Voit & Mayer, Ltd.

(57) **ABSTRACT**

An ultrasound catheter is disclosed for providing substantially real-time images of small cavities. The ultrasound catheter is characterized by separate and distinct materials for backing the transducers and for carrying the electronics components. The separate materials comprise an electronics carrier meeting the requirements for holding the integrated circuitry of the ultrasound device and a backing material displaying superior characteristics relating to reducing ringing and minimizing the effect of other sources of signal degradation in the transducer assembly. Also, in accordance with the present invention, a technique is described for connecting the conductor lines of the separate transducer assembly and electronics body.

**14 Claims, 5 Drawing Sheets**

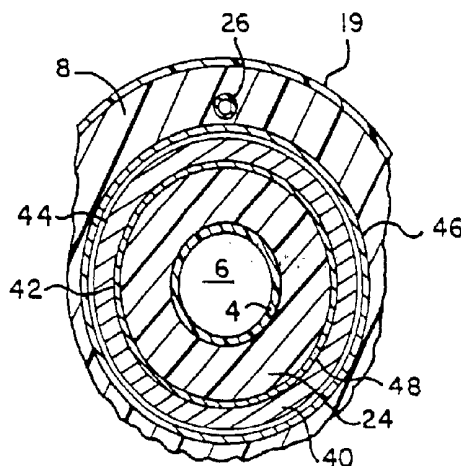

U.S. PATENT DOCUMENTS

|           |      |         |                    |         |
|-----------|------|---------|--------------------|---------|
| 4,505,156 | A    | 3/1985  | Questo             |         |
| 4,576,177 | A    | 3/1986  | Webster, Jr.       |         |
| 4,582,067 | A    | 4/1986  | Silverstein et al. |         |
| 4,589,419 | A    | 5/1986  | Laughlin et al.    |         |
| 4,641,657 | A    | 2/1987  | Ellis              |         |
| 4,645,961 | A    | 2/1987  | Malsky             |         |
| 4,665,331 | A    | 5/1987  | Sudo et al.        |         |
| 4,665,925 | A    | 5/1987  | Millar             |         |
| 4,671,293 | A    | 6/1987  | Shaulov            |         |
| 4,728,834 | A    | 3/1988  | Kumar et al.       |         |
| 4,771,782 | A    | 9/1988  | Millar             |         |
| 4,771,788 | A    | 9/1988  | Millar             |         |
| 4,794,931 | A    | 1/1989  | Yock               |         |
| 4,817,616 | A    | 4/1989  | Goldstein          |         |
| 4,821,731 | A    | 4/1989  | Martinelli et al.  |         |
| 4,841,977 | A    | 6/1989  | Griffith et al.    |         |
| 4,917,097 | A    | 4/1990  | Proudian et al.    |         |
| 4,951,677 | A    | 8/1990  | Crowley et al.     |         |
| 4,962,329 | A    | 10/1990 | Fujita et al.      |         |
| 4,975,607 | A    | 12/1990 | Hara et al.        |         |
| 5,046,503 | A    | 9/1991  | Schneiderman       |         |
| 5,081,993 | A    | 1/1992  | Kitney             |         |
| 5,109,861 | A    | 5/1992  | Walinsky et al.    |         |
| 5,117,831 | A    | 6/1992  | Jang et al.        |         |
| 5,167,233 | A    | 12/1992 | Eberle et al.      |         |
| 5,174,296 | A    | 12/1992 | Watanabe et al.    |         |
| 5,176,141 | A    | 1/1993  | Bom et al.         |         |
| 5,183,048 | A    | 2/1993  | Eberle             |         |
| 5,186,177 | A    | 2/1993  | O'Donnell et al.   |         |
| 5,199,437 | A    | 4/1993  | Langberg           |         |
| 5,226,847 | A    | 7/1993  | Thomas, III et al. |         |
| 5,240,003 | A    | 8/1993  | Lavcee et al.      |         |
| 5,243,988 | A    | 9/1993  | Sieben et al.      |         |
| 5,257,629 | A    | 11/1993 | Kitney et al.      |         |
| 5,273,045 | A    | 12/1993 | Chihara et al.     |         |
| 5,320,104 | A    | 6/1994  | Fearnside et al.   |         |
| 5,327,894 | A    | 7/1994  | Thomas             |         |
| 5,351,691 | A    | 10/1994 | Brommersma         |         |
| 5,368,037 | A    | 11/1994 | Eberle et al.      |         |
| 5,402,791 | A    | 4/1995  | Saitoh et al.      |         |
| 5,467,779 | A    | 11/1995 | Smith et al.       |         |
| 5,479,930 | A    | 1/1996  | Gruner et al.      |         |
| 5,488,957 | A    | 2/1996  | Frey et al.        |         |
| 5,779,644 | A *  | 7/1998  | Eberle et al. .... | 600/463 |
| 5,793,541 | A    | 8/1998  | Cattan et al.      |         |
| 5,938,615 | A *  | 8/1999  | Eberle et al. .... | 600/463 |
| 6,123,673 | A *  | 9/2000  | Eberle et al. .... | 600/467 |
| 6,283,920 | BI * | 9/2001  | Eberle et al. .... | 600/459 |

FOREIGN PATENT DOCUMENTS

|    |            |         |
|----|------------|---------|
| GB | 2 208 138  | 3/1989  |
| GB | 2 264 236  | 8/1993  |
| GB | 2 274 736  | 8/1994  |
| JP | 54149615   | 11/1979 |
| JP | 57121400   | 7/1982  |
| JP | 02-265533  | 10/1990 |
| JP | 02-265534  | 10/1990 |
| JP | 2271843 A2 | 1/1991  |

|    |             |         |
|----|-------------|---------|
| JP | 3153198 A2  | 1/1991  |
| WO | 1402192     | 8/1975  |
| WO | WO 88/09150 | 12/1988 |
| WO | WO 89/04142 | 5/1989  |
| WO | WO 91/07928 | 6/1991  |
| WO | WO 91/17785 | 11/1991 |
| WO | WO 93/02809 | 1/1993  |
| WO | WO 93/14803 | 8/1993  |
| WO | WO 93/15419 | 8/1993  |
| WO | WO 94/01786 | 1/1994  |
| WO | WO 94/16624 | 8/1994  |

OTHER PUBLICATIONS

Pasterkamp, G., et al., "Discrimination of the Intravascular Lumen and Dissections In A Single 30-MHz US Image: Use of 'Confounding' Blood Backscatter To Advantage," *Radiology*, vol. 187, no. 3, pp. 871-872 (Jun. 1993).

Martin et al., "Signal Enhancement for Automatic Identification of Arterial Wall Echos From An Intravessel Scanner," *Ultrasound In Medicine*, vol. 4, pp. 417-431, (New York 1978).

Weinstein, "Polyvinylidene Fluoride Acoustic Transducers and Imaging Arrays," Ph.D. Thesis, Stanford University, (Oct. 1982).

Swartz et al., "On the Generation of High-Frequency Acoustic Energy with Polyvinylidene Fluoride," *IEEE, SU #27*, (Nov. 1980).

Ohigashi et al., "Piezoelectric & Ferroelectric Properties of P (VDF-TeFE) Copolymers & Their Application to Ultrasonic Transducers," *Ferroelectrics*, vol. 60, pp. 263-276, (1984).

Macovski, "Ultrasonic Imaging Using Arrays," *Proc. IEEE*, vol. 67, no. 4, pp. 484-495, (Apr. 1979).

Martin et al., "An Ultrasonic Catheter for Intravascular Measurement of Blood Flow: Technical Details," *IEEE*, vol. Su-27, no. 6, pp. 277-286, (Nov. 1980).

Kino, "Acoustic Waves: Devices, Imaging, and Analog Signal Processing," pp. 554-559 (1987).

Wells, "Biomedical Ultrasonic," pp. 49-55, (1977).

Lockwood et al., "A 45 to 55 MHz Needle-Based Ultrasound System for Invasive Imaging," *Ultrasonic Imaging*, vol. 15, no. 1, pp. 1-13, (Jan. 1993).

EPO Application EP 96202546—Notification of European Publication Number and Information on the Application of Article 67(3) EPC, dated Nov. 20, 1996, including European Search Report, dated Oct. 23, 1996.

Black et al., "CMOS Chips for Invasive Ultrasound Imaging," *IEEE Journal of Solid-State Circuits*, 29 (11), 1381-1387 (1994).

O'Donnell et al., "Experimental Studies on an Efficient Catheter Array Imaging System," *Ultrasonic Imaging*, 17 (2), 83-94 (1995).

PCT International Search Report for Application PCT/US96/20655, mailed May 14, 1997.

\* cited by examiner

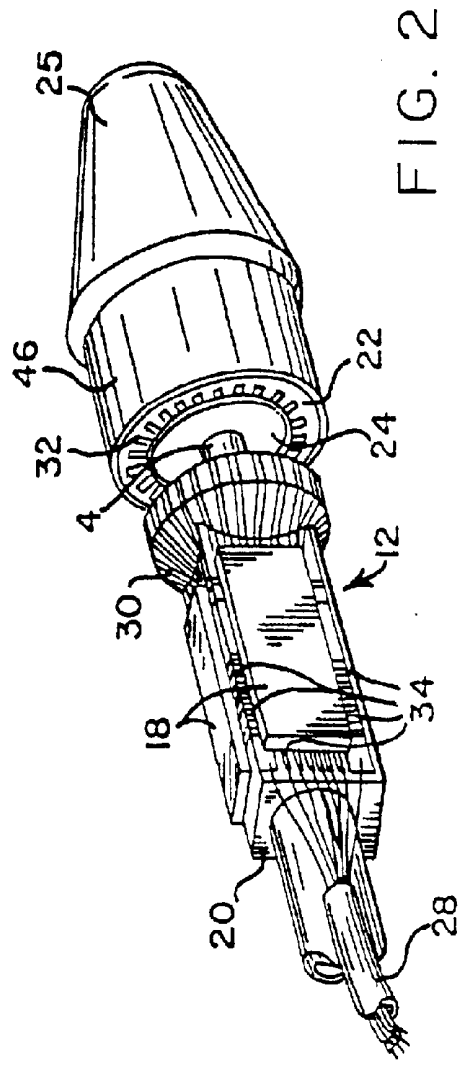
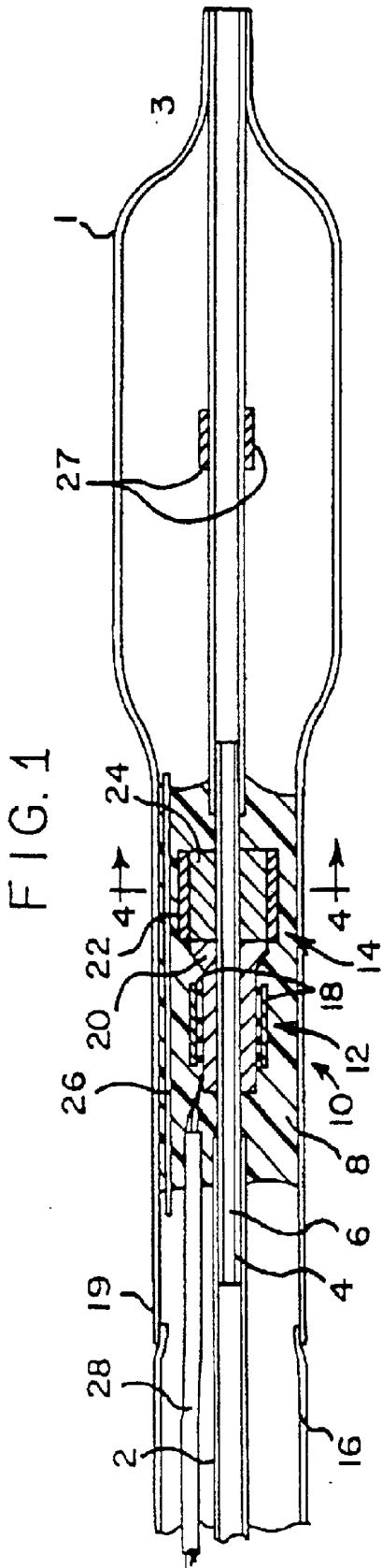

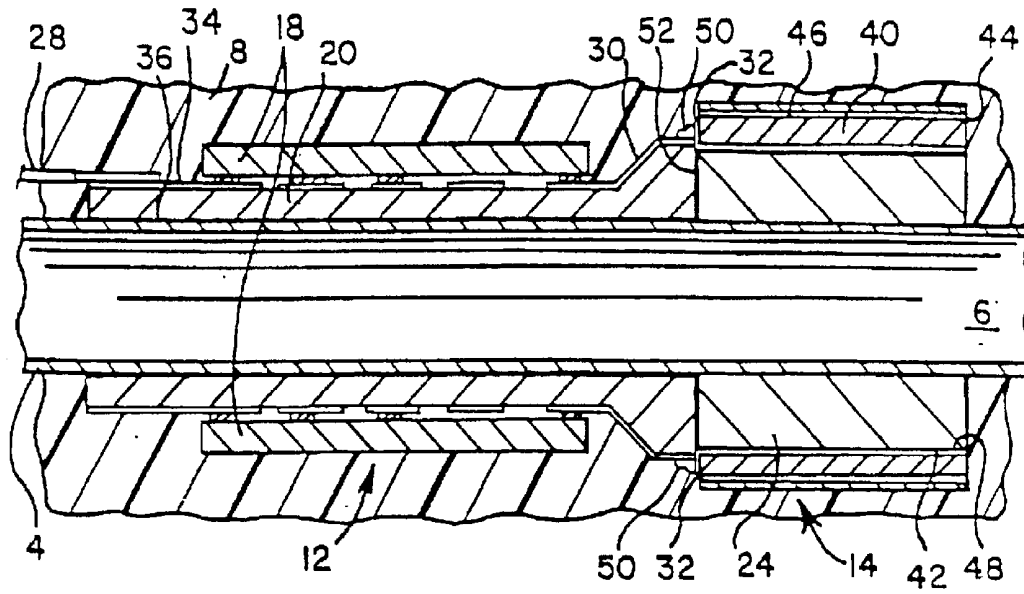

FIG. 3

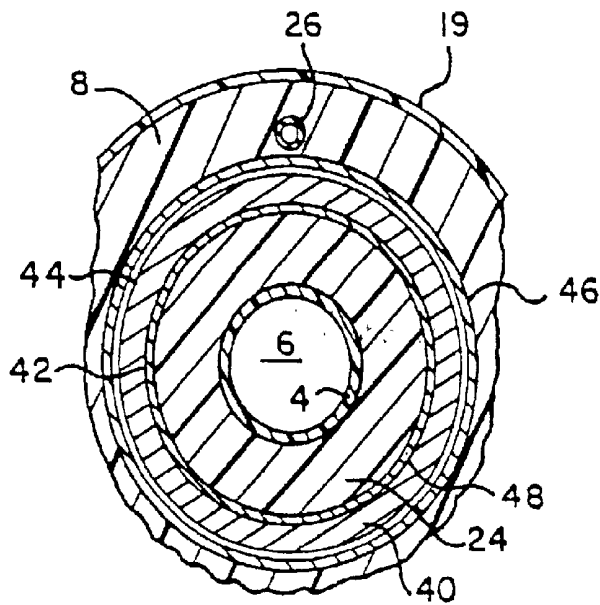

FIG. 4

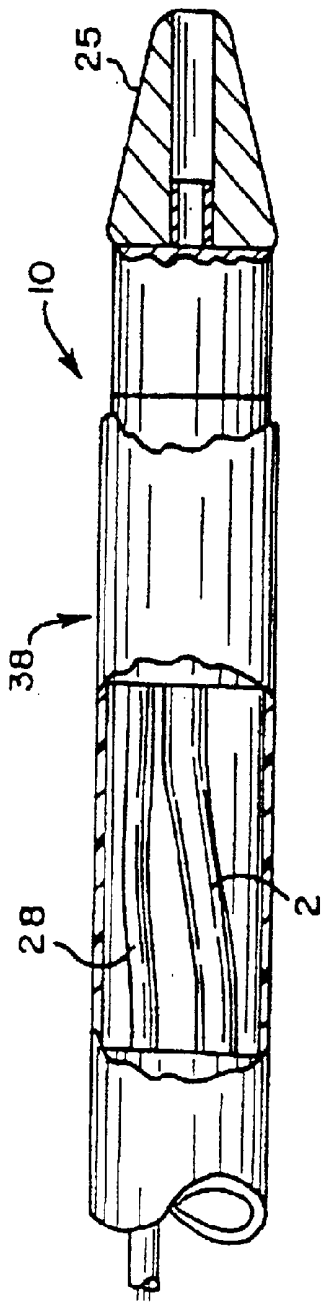

FIG. 6

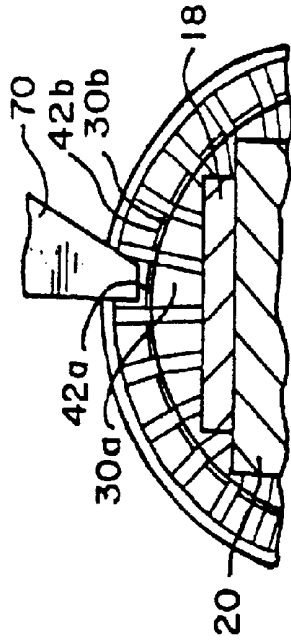

FIG. 5B

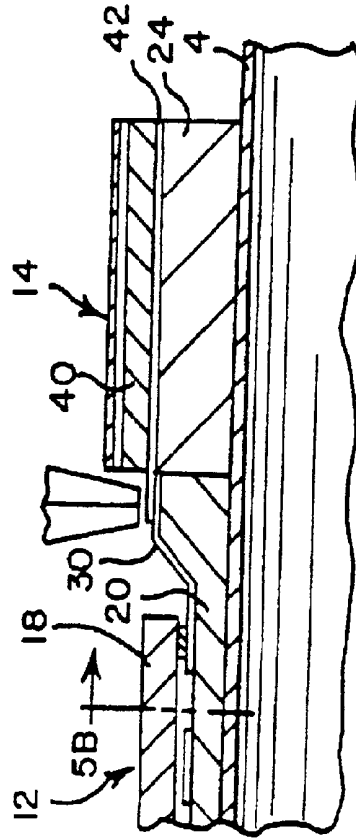

FIG. 5A

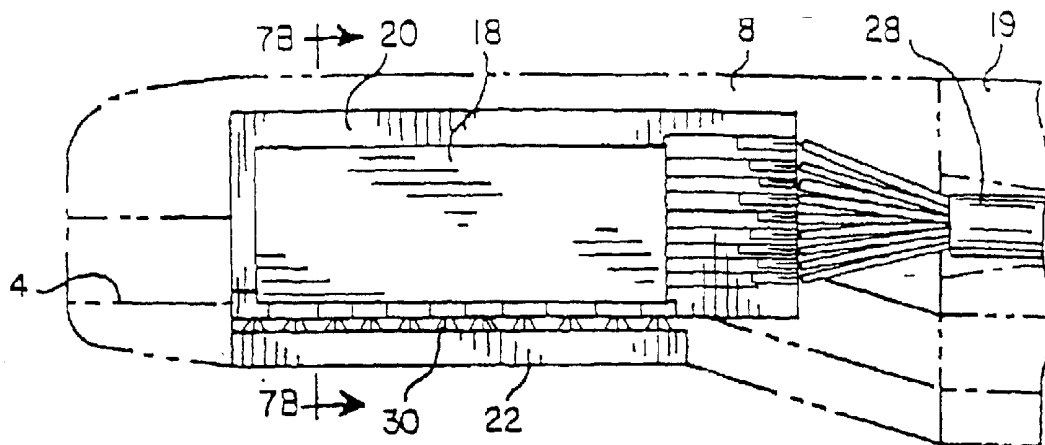

FIG. 7A

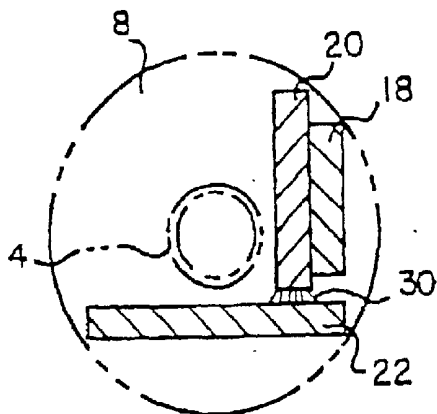

FIG. 7B

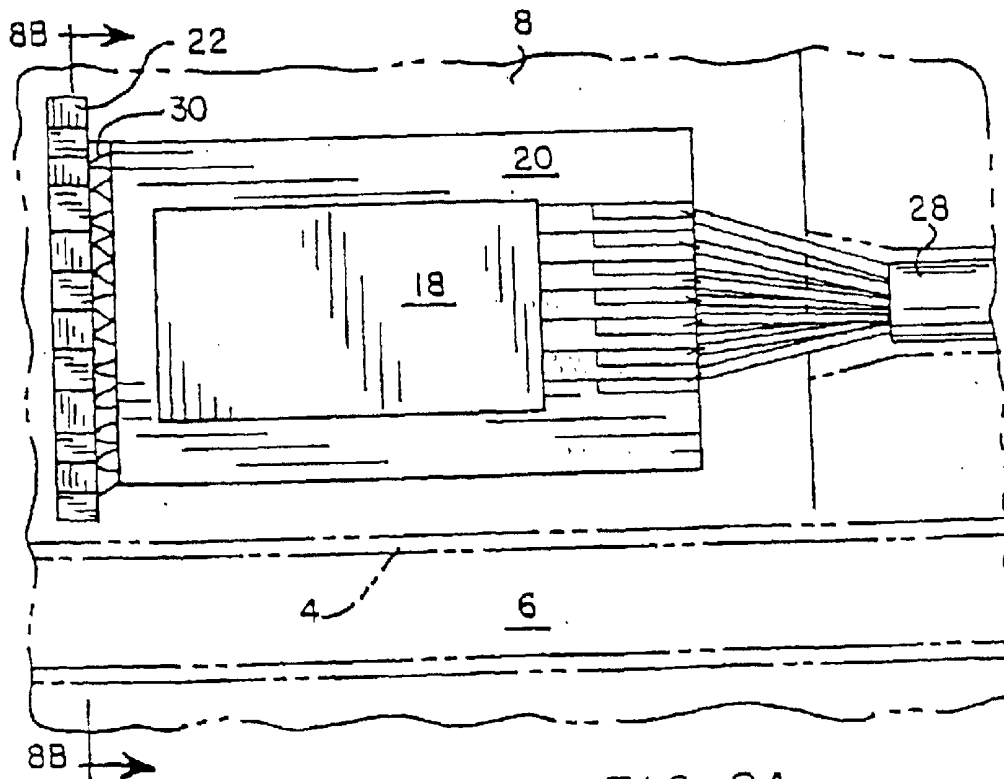

FIG. 8A

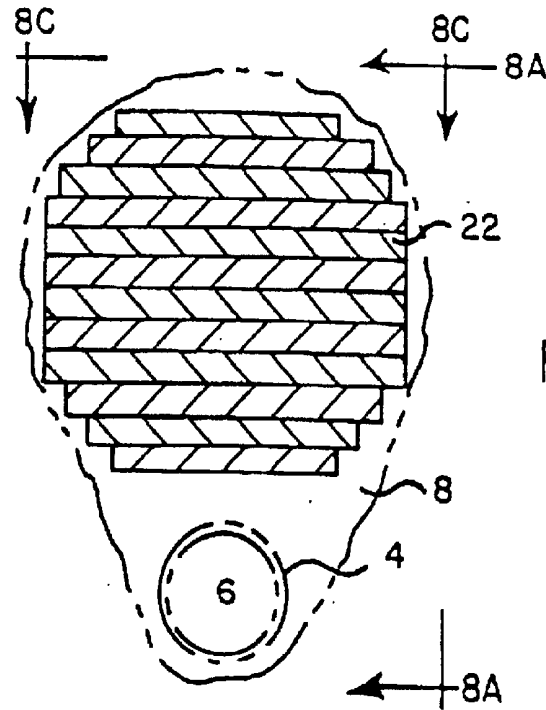

FIG. 8B

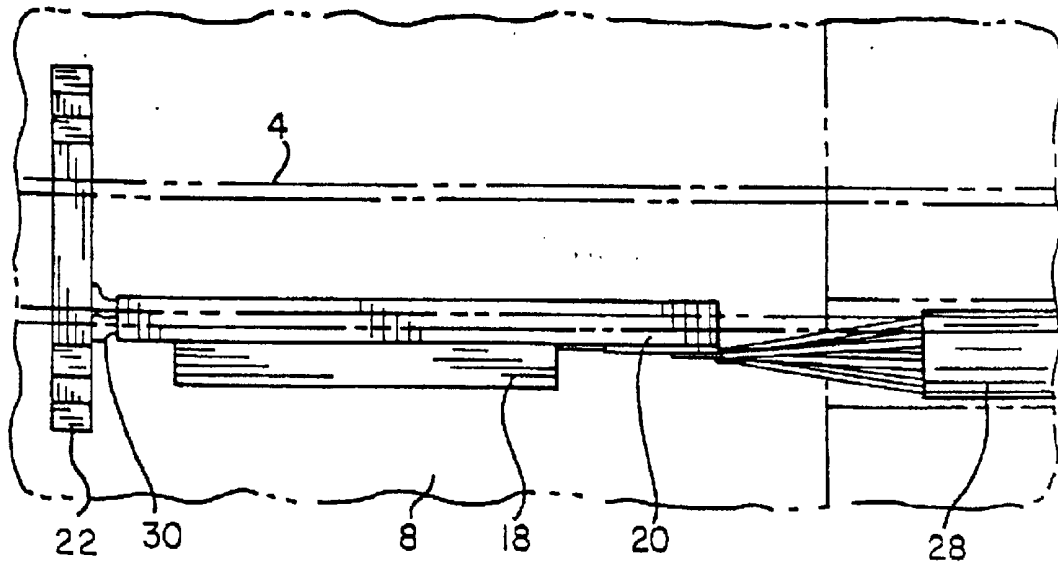

FIG. 8C

**ULTRASOUND TRANSDUCER ASSEMBLY**

This application is a continuation of Ser. No. 09/658,323, filed Sep. 8, 2000, now Pat. No. 6,283,920, which is a continuation of Ser. No. 09/324,692, filed Jun. 2, 1999, now Pat. No. 6,123,673 which is a continuation of Ser. No. 08/935,930, filed Sep. 23, 1997, now Pat. No. 5,938,615; which is a division of Ser. No. 08/712,166, filed Sep. 11, 1996, now Pat. No. 5,779,644; which is a continuation of Ser. No. 08/516,538, filed Aug. 18, 1995, now Pat. No. 5,603,327; which is a continuation of Ser. No. 08/234,848, filed Apr. 28, 1994, now Pat. No. 5,453,575; which is a continuation-in-part of Ser. No. 08/012,251, filed Feb. 1, 1993, now Pat. No. 5,368,037.

**INCORPORATION BY REFERENCE**

The applicants hereby incorporate by reference the description of an "Apparatus and Method for Imaging Small Cavities" described in Proudian et al. U.S. Pat. No. 4,917,097, the description of a "Dilating and Imaging Apparatus" described in Eberle et al. U.S. Pat. No. 5,167,233, and the description of an "Apparatus And Method For Detecting Blood Flow In Intravascular Ultrasonic Imaging" in O'Donnell et al. U.S. No. 5,453,575.

**FIELD OF THE INVENTION**

The present invention relates generally to the field of ultrasonic imaging, and more particularly to ultrasonic imaging to determine various characteristics of relatively small cavities and surrounding fluids and structures.

**BACKGROUND OF THE INVENTION**

Diagnosis and treatment of fully or partially blocked arteries of the heart is essential in the medical profession's endeavor to prevent heart attacks. Physicians have successfully prevented heart attacks arising from artery blockage caused by the build-up of plaque upon the walls of the coronary arteries through the use of percutaneous transluminal coronary angioplasty (PTCA, commonly referred to as "balloon angioplasty"). Balloon angioplasty involves carefully threading a catheter into the affected portion of the artery. After the balloon portion is determined to be properly positioned in the artery, the physician inflates the expandable portion of the catheter in order to broaden the blocked or narrowed passage in the blood vessel caused by the deposition of plaque upon the artery wall.

The desirability of using an imaging device to produce treatment and diagnostic quality images of small enclosed areas such as human blood vessels on a diagnostic video display device is unquestioned. It is known to use a very small ultrasonic imaging device mounted at the end of a catheter to produce a real-time image of the internal walls of a coronary artery. This device is referred to herein as an ultrasound catheter.

In the known ultrasound catheters, the same material is used for the electronics carrier upon which a set of electronic components are mounted and for the backing material for the transducer assembly. A drawback to the known ultrasound catheters is the difficulty in finding a carrier/backing material which provides the physical and acoustic qualities desired for advantageous use as the carrier for the electronics and the backing material for a transducer assembly comprising a highly sensitive transducer material.

The known ultrasonic catheter structure, though providing the advantage of design and construction simplicity, exhibits

certain drawbacks attributable to the particular and mutually incompatible requirements for the backing material and the electronics carrier. It is desirable that the electronics carrier for the electronics body be rigid and capable of withstanding the elevated temperatures produced by the electronics. However, the known electronics carrier materials which satisfy the requirements for the electronics body are not suitable backing materials for the presently preferred transducer assemblies comprising highly sensitive lead zirconate titanate (PZT) composites.

When the new, more sensitive PZT composites are used with the known electronic carrier material as the backing material for the transducer, unwanted ringing occurs in the transducer assembly when an acoustic signal is received or transmitted by the catheter. The signal produced by the ringing reduces the quality of the signal transmitted by the transducer assembly and limits the foreseeable advantages of utilizing the more sensitive transducer materials in ultrasonic catheters. The decreased signal quality attributed to the ringing limits the image quality provided by an ultrasound catheter. The limited image quality restricts the usefulness of the ultrasound catheter for clinical and diagnostic imaging.

In known ultrasound catheters the transducer electrodes are coupled to the transducer layer through a capacitive glue layer. As was previously mentioned, PZT composites having a relatively high degree of sensitivity to acoustic signals are being considered for replacement of the previously used, less sensitive, ferroelectric polymer transducer materials. While the PZT composites exhibit superior sensitivity in comparison to the ferroelectric copolymers, they also have a higher dielectric constant. The reduced impedance (or increased capacitance) associated with the new PZT composites significantly negates the improved signal sensitivity provided by the PZT composites when coupled to the transducer electrodes through the capacitive glue layer.

**SUMMARY OF THE INVENTION**

It is an object of the present invention to provide a superior virtually real-time ultrasonic image of relatively small cavities and their surrounding tissues than previously obtainable in the prior art.

It is a further object to provide enhanced sensitivity to reflected signals from the walls of a cavity in order to provide improved image resolution.

It is a further object of the invention to meet the other objectives and maintain or reduce ringing and other sources of noise in a signal transmitted or received by the transducer assembly and to thereby provide a clearer image of a cavity.

It is yet another object of the present invention to provide a means for more easily fabricating the very small transducer elements of the transducer assembly of an ultrasound catheter.

It is yet another object of the present invention to provide a means for forming the very small transducer elements for the ultrasound catheter to very close tolerances.

It is another object of the present invention to provide desirable carrier/backing materials for the electronics body and transducer assembly of an ultrasound catheter.

It is yet another object of the present invention to provide a means for joining the conductor lines of the electronics body to the conducting electrodes of the transducer assembly in order to provide a signal path between the separately fabricated sections containing the integrated circuits and the transducer assembly of an ultrasound catheter.

The above objects are met by a catheter probe assembly of the present invention comprising a multi-sectioned body



for insertion into a cavity. The multi-sectioned body is characterized by separate and distinct carrier/backing materials for an electronics body and a transducer assembly. The present invention comprises a probe assembly for an ultrasound catheter generally of the type described in Proudian deceased et al. U.S. Pat. No. 4,917,097 and Eberle et al. U.S. Pat. No. 5,167,233 for producing substantially real-time images of small cavities and their surrounding tissue.

The transducer assembly, comprising an array of transducers is mounted upon a first section of the multi-sectioned body. The transducer array transmits ultrasonic acoustic waves to the cavity and generates electrical signals in response to reflected ultrasonic acoustic waves received by the transducers.

The backing material for the transducer assembly is specifically selected for its characteristic low acoustic impedance and high absorption. The low acoustic impedance backing material absorbs signals coupled into the transducer assembly. In addition, a set of transducer electrodes are directly bonded to the transducer material thereby eliminating a capacitive glue layer previously associated with the transducer circuits.

Integrated circuits are mounted upon a second section of the multi-sectioned body. The second section, acoustically isolated from the first section, comprises a carrier material having a low thermal expansion coefficient. The integrated circuits receive a set of first electrical signals from the transducer array by means of electrical conductors interconnecting the transducer assembly electrodes and the pads of the integrated circuits. The electrical conductors are also used to transmit excitation signals from the integrated circuits to the transducer assembly. The integrated circuits convert the received first electrical signals into a second set of electrical signals. Then the integrated circuits transmit the second set of signals to a signal processor located outside the environment of the cavity by means of a cable.

The unique, multi-sectioned, structure of the probe assembly enables the designer of the probe assembly to separately select a material exhibiting the preferred structural and acoustic characteristic for the carrier of the integrated circuit components and the backing material for the transducer elements.

In order to prevent damage to the components of both the transducer assembly and the electronics body, these two portions of the ultrasound catheter probe assembly are separately manufactured and linked during the final stages of fabrication of the ultrasonic catheter.

#### BRIEF DESCRIPTION OF THE DRAWINGS

The appended claims set forth the features of the present invention with particularity. The invention, together with its objects and advantages, may be best understood from the following detailed description taken in conjunction with the accompanying drawings of which:

FIG. 1 is a side cross-sectional view of the tip of a catheter illustrating the electronics body, the transducer assembly, and the balloon section of a balloon angioplasty ultrasound imaging catheter embodying the present invention;

FIG. 2 is a perspective view of the tip of a partially constructed diagnostic imaging catheter prior to joining the signal paths between the separated electronics body and transducer assembly;

FIG. 3 is a detailed side cross-sectional view of the tip of the imaging device portion of the catheter showing the composition of the imaging device;

FIG. 4 is a cross-sectional view of the transducer assembly taken along line 4—4 in FIG. 1;

FIGS. 5a and 5b illustratively depict an alternative embodiment of the ultrasound catheter wherein the conducting electrodes in the transducer assembly extend beyond the backing material and the transducer material;

FIG. 6 is a side cross-sectional view of the tip of a catheter illustrating the electronics body, transducer assembly, and nose assembly of an ultrasound diagnostic imaging catheter embodying the present invention;

FIGS. 7a and 7b show cross-sectional and side-sectional views of an alternative embodiment of the present invention wherein the transducer array is configured to provide a "side-looking" view; and

FIGS. 8a, 8b and 8c show side, forward, and top cross-sectional views of an alternative embodiment of the present invention wherein the transducer array is configured to provide a "forward-looking" view.

While the invention will be described in connection with a catheter used for angioplasty, it will be understood that it is not intended to be limited to such use. On the contrary, the invention is intended to cover all applications which may require imaging in a small cavity. An example of such an alternative would be the use of the present invention on a catheter without the balloon. In such a case, the catheter acts as a diagnostic or monitoring device. Another specific alternative use of the present invention is for measuring blood flow rates using Doppler sound imaging in conjunction with the present invention. The present invention may also be used to produce internal images of a number of ducts within a body such as the monitoring of gall stones in the bile ducts and for examination and treatment in the area of urology and gynecology. Another example of an application of the present invention is the use of the ultrasound catheter for providing an image of a vessel or duct during application of laser treatment or during the removal of plaque from the walls of a vessel during an antherectomy procedure.

Furthermore, this invention may be applied to other types of transducer array configurations which will be known to those of ordinary skill in the art in view of the description of the invention and the accompanying descriptions of various embodiments of this invention contained herein.

#### DETAILED DESCRIPTION OF THE PREFERRED EMBODIMENT

Though the present invention concerns the structure of the carrier/backing material for the electronics body and transducer assembly and changes to the physical layers of the transducer assembly, the invention is intended to be incorporated in general into an ultrasound catheter imaging system of the type described in Proudian, deceased et al. U.S. Pat. No. 4,917,097 the teachings of which are incorporated herein by reference. Furthermore, the present ultrasound catheter may be used to obtain images using a number of different imaging techniques including, for example, the imaging technique described in O'Donnell et al. U.S. Pat. No. 5,453,575, the teachings of which are expressly incorporated herein by reference.

A cross-sectional view of a catheter embodying the present invention is illustratively depicted in FIG. 1. The catheter shown in FIG. 1 carrying a balloon 1 is of the type which is generally used for angioplasty; however, the invention can be used in conjunction with a number of catheter designs such as those illustratively depicted in FIGS. 6, 7 and 8 to provide diagnostic images and deliver treatment to small cavities of the body. Conventional guide wire lumens

2 and 3 are telescopically fitted over a mating radiopaque guide wire lumen 4 forming a central bore 6 for a catheter guide wire during a normal catheterization procedure. An encapsulant 8 composed of an epoxy material secures an imaging device 10 comprising the electronics body 12 and the transducer assembly 14 to the end of a catheter shaft 16. The imaging device 10 in accordance with the present invention contains a multi-sectioned body comprising separate and distinct materials for a carrier 20 and a transducer backing material 24. The encapsulant 8 protects and insulates a set of integrated circuits (IC's) 18 mounted upon the carrier 20. In the preferred embodiment of a balloon angioplasty device embodying the present invention, the imaging device 10 is positioned within a proximal sleeve 19 of the balloon 1.

The transducer assembly 14, described hereinafter in greater detail in conjunction with FIG. 3, generally comprises a set of transducer elements 22. The transducer elements 22 are supported in a cylindrical shape about the backing material 24. However, other transducer element configurations will be known to those skilled in the area of transducer devices in view of the present description and in view of the state of the art.

Continuing with the description of FIG. 1, the balloon 1 is positioned adjacent the imaging device 10 and is isolated from ambient conditions by sealing the two ends of the balloon 1 to the catheter shaft 16 and the lumen 3 in a conventional manner. A tube 26 is embedded within the encapsulant 8 for communicating a fluid between the balloon 1 and an inflation source. Within the expandable portion of the balloon 1 and attached to the lumen 3 is a radiopaque marker band 27 to assist in locating the position of the catheter on a fluoroscope.

A cable 28 comprising an inner and outer set of wires carries electronic data and control signals between the IC's 18 and a control station computer. Each inner wire in the cable 28 is formed from a solid conductor protected by an insulating coating. The outer wires are spiraled a number of times around the cable 28 in order to shield the signals carried by the inner wires of the cable 28. Preferably, the cable is coated with an insulating material.

Turning now to FIG. 2, a perspective view is provided of the tip of a partially constructed diagnostic imaging catheter 10 prior to joining the signal paths between the separated electronics body 12 and transducer assembly 14 in order to show the distinct first and second portions of the imaging device 10 comprising the transducer assembly 14 and the electronics body 12. To aid the description of the imaging device 10, the proximal sleeve 19 and the epoxy encapsulant 8 covering the imaging device 10 have been removed to expose the integrated circuit chips 18 and associated electronic constructions. A nose cone 25 provides a blunted lead surface for the ultrasound imaging catheter in order to prevent damage to a vessel as the catheter is guided through the vessel.

The radiopaque guide wire lumen 4, visible within a patient by means of a fluoroscope, aids in the positioning of the catheter. The radiopaque guide wire lumen 4 also holds both the electronics body 12 and the transducer assembly 14. The outer diameter of the radiopaque guide wire lumen 4 is approximately 0.5 millimeters. The radiopaque guide wire lumen 4 provides the additional function of acting as a guide for precisely positioning the electronics body 12 and transducer assembly 14 in order to mate a set of 64 conductor lines 30 from the IC's 18 mounted upon the electronics body 12 to a set of 64 transducer contacts 32 of the transducer

assembly 14 in a manner shown in FIG. 3. In order for the radiopaque guide wire lumen 4 to assist in mating the above described components of the imaging device 10, the gap between the radiopaque guide wire lumen 4 and both the carrier 20 and the backing material 24 must be very small and should not be greater than approximately 25  $\mu\text{m}$ . This minimized gap ensures proper radial alignment of the conductor lines 30 and transducer contacts 32.

In order to physically place the IC's 18 onto the carrier 20, the four IC's 18 are of an inverted chip design known to those skilled in the area of the semiconductor chip fabrication art and are bonded to a set of conductive pads 34 formed on the carrier 20. The conductive pads 34 interconnect the IC's 18 to their neighboring chips and provide a connection between the IC's 18 and the cable 28 that communicatively couples the IC's 18 to a signal processor located outside the patient. The pads also connect the IC's 18 to the conductor lines 30. The conductor lines 30 link the IC's 18 to a set of 64 electrodes that define the transducer elements in the transducer assembly 14.

Each of the IC's 18 has 16 channels associated with 16 transducer elements defined by 16 transducer electrodes in the transducer assembly 14. Each of the four IC's 18 is responsible for sequentially transmitting and receiving electrical signals in the ultrasonic frequency range on one or more of its 16 channels linked by conductor lines 30 to an associated transducer element in the transducer assembly 14. The four IC's 18 provide a multiplexing function that distributes excitation pulses from a signal processor to one or more of the transducer elements. At any given time one or more of the 16 channels on each of the IC's 18 is free to be excited by an excitation signal or to receive reflections or echoes by means of activation control signals stored on the IC's 18. The electrical signals generated from the reflections impinging on the active transducer elements are amplified and sent via the transmission cable line 28 to the external signal processor.

Turning to FIG. 3 a detailed side cross-sectional view of the imaging portion of the catheter of FIG. 1 is illustrated to show the structure and materials of the imaging device 10. In this drawing the electronics body 12 and the transducer assembly 14 are shown in their mated state as they would exist in the final construction of the imaging catheter. Though the layers of the transducer assembly are shown in detail in FIG. 3 it will be helpful to refer to FIG. 4, a cross section view of the transducer assembly taken along line 4-4 of FIG. 2, during the description of the ringed layers of the transducer assembly 14.

The carrier 20 is bonded to the radiopaque guide wire lumen 4 by means of a glue layer 36 comprising any commercially available medical grade cyanoacrylate epoxy. One may substitute any material or structure that satisfactorily immobilizes the electronics body 12 for the glue layer 36. As previously mentioned the space between the radiopaque guide wire lumen 4 and the carrier 20 filled by the glue layer 36 must be very small in order for the radiopaque guide wire lumen 4 to assist in the matching of the electrical contacts between the electronics body 12 and the transducer assembly 14.

The carrier 20 in the preferred embodiment of the invention is formed from a rigid, strong material having a low thermal expansion coefficient. The carrier 20 must be capable of withstanding temperatures in excess of 200 degrees Celsius to which the electronics body 12 is subjected during the process of bonding the set of IC's 18 to the carrier 20. Furthermore, during operation of the ultrasound

catheter, self-heating of the IC's 18 may cause expansion of the carrier 20. If the thermal expansion of the carrier 20 is too great, shear forces exerted by the carrier 20 upon the conductive pads 34 create a substantial risk of failure of the electrical connection between the contacts of the IC's 18 and the conductor lines 30. Aluminum oxide (Al<sub>2</sub>O<sub>3</sub>) possesses the aforementioned desired characteristics for the carrier 20; however, other suitable substitutes for this material are well known to those skilled in the art of hybrid circuits. Aluminum oxide is also characterized by a very high acoustic impedance (approximately 40 MRays) and relatively low loss. As will be explained below, these acoustical properties make Aluminum oxide a poor candidate for use as the transducer backing material for applications involving highly sensitive transducer elements.

An encapsulant 8 is applied to the outer surface of the electronics body 12 in order to provide a more cylindrical shape to the catheter assembly and to insulate the electronic circuitry. The encapsulant 8 generally comprises any commercially available medical grade UV-curable acrylic. In order to guard against contamination of the blood and possibly electrical shock, the outside of the electronics body may be covered by a protective layer. The protective layer is made of, for example, parylene. Other suitable materials for the protective layer will be known to those skilled in the art of ultrasound catheters or other medical instruments which are inserted within the body. The protective layer consists of the proximal sleeve 19 in the balloon angioplasty catheter shown in FIG. 1 or a sheath 38 in the case of a diagnostic imaging catheter such as the one illustrated in FIG. 6.

Turning to the transducer assembly 14 and its related structures, the backing material 24 for the transducer assembly 14 is preferably formed from a material characterized by a relatively low acoustic impedance (<10 MRays) and high loss coefficient (on the order of 20 to 40 dB/mm). This is necessitated by the use of highly sensitive transducer materials such as the PZT composites used for a transducer material 40 whose superior signal sensitivity is otherwise negated by the ringing effect caused by a backing material having a high acoustic impedance and low loss. For this reason, Aluminum oxide is not a preferred material for the backing material 24 for the transducer assembly 14. Instead, a separate and different material is used to form the backing material 24 for the ultrasound catheter of the present invention. A preferred material for the backing material 24 is an epoxy resin filled with either rubber particles or glass microspheres. An example of such a resin is "light-weld" 183-M by Dymax Corp., Torrington, Conn. Other suitable materials having low acoustic impedance and high loss will be known to those of ordinary skill in the art of ultrasound imaging. Although air is an ideal backing material, transducer assemblies using an air backing are difficult to achieve in practice.

Thus, the ultrasound catheter of the present invention is characterized by an imaging device 10 having separate and distinct carrier/backing materials that exhibit greatly contrasting characteristics. The two distinct materials provide desirable structural and acoustical characteristics for satisfying the dissimilar requirements for the electronics body 12 and the transducer assembly 14.

In the preferred method of making the transducer assembly 14, the outer layers of the transducer assembly 14 are separately manufactured as a planar sheet. They comprise a first set of 64 conducting electrodes 42, the transducer material 40, a continuous layer conducting electrode 44, and a matching layer 46. After the layers are fabricated, the planar sheet of transducer elements 22 is wrapped around

the backing material 24 and bonded by means of a glue layer 48. Depending on the mechanical and acoustic properties of the transducer assembly 14, physical isolation of the transducer elements 22 from one another may be desirable. Since a uniform distribution of each of the transducer elements 22 is desired, the outer diameter of the backing material 24 must be manufactured within very close tolerances so that the ends of the planar sheet of transducer elements, when joined to form a cylinder around the backing material 24, meet with minimal gap or overlap. Alternatively, the planar transducer assembly 14 may be formed into a cylinder of exact outer diameter concentrically around the radiopaque lumen 4 and the gap between the lumen 4 and the transducer assembly 14 is filled with the backing material 24. This ensures that the spacing between the transducer array elements at the opposite ends of the cylindrically wrapped planar sheet have the same spacing as the other transducer array elements. It is believed that the error in the circumference of the transducer sheet, when wrapped around the lumen 4, should be less than (plus or minus) 8 μm. Furthermore, the inner diameter of the backing material 24 must closely match the outer diameter of the radiopaque guide wire lumen 4 in order to facilitate the mating of electrical contacts between the electronics body 12 and the transducer assembly 14. The concentric rings comprising the afore-described layers of the transducer assembly 14 are illustratively depicted in FIG. 4 showing a cross-sectional view of the transducer assembly taken on line 4—4 of FIG. 1.

An advantage of the planar sheet transducer element fabrication method is the absence of capacitive glue layers previously present between the transducer material 40 and each of the conducting electrodes 42 and 44. If the capacitive glue layer remained in the presently described ultrasound catheter, an increased capacitance attributable to the higher dielectric constant of the PZT composite transducer material 40 would negate the improved signal sensitivity of the preferred transducer material. There are several other advantages to the sheet approach to fabricating the transducer array. Fabrication on a flat surface is easier than on a curved, cylindrical surface. This is especially important in transducer assemblies wherein the transducer material 40 must be separated (or diced) in order to form the transducer material on the continuous conducting electrode 44 as individual elements instead of a continuous sheet. The capability of fabricating the transducer material 40 as individual elements is an important factor when choosing a particular fabrication method in view of the desirability of low cross-talk (less than -30 dB), which may necessitate such a separation of elements. Some of the possible manufacturers of the planar sheets comprising the transducer elements are: Precision Acoustic Devices, Fremont, Calif.; Acoustic Imaging, Phoenix, Ariz.; Echo Ultrasound, Lewistown, Penn.; Vermon S. A., Tours, France; and Imasonic, Besancon, France.

After the transducer assembly 14 has been formed, it may be desirable for the transducer material to be polarized by means of a high voltage on the order of 5,000 Volts applied between the first set of conducting electrodes 42 and the continuous conducting electrode 44. Therefore, it is desirable to perform the polarization procedure on a separated assembly to isolate the transducer assembly 14 from the electronics body 12 since application of such a high voltage to the IC's 18 would destroy the electronic circuitry of the IC's 18.

The layer of glue 48 bonds the backing material 24 to the first set of conducting electrodes 42 spaced evenly about the

circumference of the backing material **24**. The first set of conducting electrodes **42** defines the individual transducer elements in the transducer array. The first set of conducting electrodes **42** is attached to the set of 64 transducer contacts **32**. Connection material **50** electrically couples each one of the transducer contacts **32**, corresponding to a single transducer element, to a corresponding one of the conductor lines **30**, thereby providing an electronic signal path between the transducer elements **22** and the IC's **18**. The connection material comprises any of several known suitable conductors such as silver or gold loaded epoxy droplets, solder or gold bumps, or solder tape.

There are other connection schemes for joining the conducting electrodes **42** to the conductor lines **30**. FIGS. **5A** and **5B** illustratively depict an alternative embodiment of the ultrasound catheter wherein copper conducting electrodes **42** of the transducer assembly **14** extend beyond the backing material **24** and the transducer material **40**. The portion of the conducting electrodes **42** extending beyond the backing material **24** and overlapping the conductor lines **30** when the transducer assembly **14** is joined to the electronics body **12** facilitates the use of a well known gap welder to fuse the individual conductor lines **30** to the corresponding conducting electrodes **42**.

FIG. **5A** shows a cross-sectional view of a partially constructed ultrasound catheter to show the above described connection scheme. The use of a gap welder eliminates the need to deposit individual drops of solder material **50** as shown in FIG. **3**. The elimination of solder droplets potentially simplifies the design of the electronics carrier **20** that may otherwise require scalloping of the carrier at the end proximate the transducer assembly **14** in order to facilitate proper deposition of the droplets to fuse the conductor lines **30** and the transducer contacts **32**. Other advantages of this connection scheme include better bonding of the conductors, simpler assembly techniques, and enhanced mechanical stability.

Another advantage of the connection scheme portrayed in FIGS. **5A** and **5B** is the potential to automate the process of bonding the conducting electrodes **42** to the conductor lines **30**. As shown in the cross-sectional view of a partially assembled ultrasound catheter assembly in FIG. **5B**, the conductor lines **30** are matched to the conducting electrodes **42**. Next, a tip **70** of a gap welder is placed above one of the matched lines. The tip **70** presses a conducting electrode **42a** to a corresponding conductor line **30a**. A low voltage, high electrical current passes between the electrodes of the tip **70**. The electrical current fuses the conducting electrode **42a** to the conductor line **30a**. Next, the catheter assembly is rotated so that a next matched set of lines (**42b** and **30b**) is below the tip **70** and the welding process is repeated. The welding continues until all the lines have been fused.

Returning now to ultrasound imaging device in FIG. **3**, there exists a range of suitable transducer materials which can be used to transduce electrical energy into acoustic energy and vice versa in the Megahertz frequency range. In the preferred embodiment of the present invention, the efficiency rating of the transducer material, expressed in terms of the coupling coefficient  $k_p$ , is high (greater than 50%); the bandwidth should be high (greater than 50% of center frequency); there should be good matching among the transducer elements; there should be low insertion loss (less than -40 dB); and the center frequency should be around 20 MHz. Therefore, in the preferred embodiment of the present invention, the transducer material **24** is any one of many known suitable PZT composites. A summary of the properties of the PZT composites is provided in *Acoustic Waves:*

*Devices, Imaging, and Analog Signal Processing*, by Professor Gordon S. Kino, Prentice-Hall, Inc., 1987 at pages 554 and 555. Generally, these composites may be damaged by temperatures exceeding 75° Celsius and could not be present when the bonding of the IC's **18** to the carrier **20** occurs.

The radial thickness of the transducer layer **40** is preferably one-half wavelength thickness or an odd multiple of half wavelengths of the intended center operating frequency of the ultrasound catheter. As explained in *Biomedical Ultrasonics*, at page 53, this enables the transducer to resonate at the center operating frequency of the ultrasound catheter. In the present embodiment, the radial thickness of the transducer material **24** is approximately 0.1 millimeters.

In order to take advantage of the superior signal sensitivity of transducers formed from PZT composites, the backing material **24** must have a low acoustic impedance. Therefore, the aluminum oxide carrier **20** having a high acoustic impedance should not be used as the backing material **24**. Instead the previous monolithic carrier for both the electronics body **12** and the transducer assembly **14** is replaced by the separated carrier/backing sections **20** and **24**.

The continuous conducting electrode **44** covering the outer surface of the transducer material **40** is the ground plane for the transducer elements **22**. It is preferably a layer of gold metal deposited upon the surface of the matching layer **46** by means of sputtering. However, other suitable conductors and methods to deposit the conductor will be known to those skilled in the art of transducers fabrication. Though not essential to the proper operation of the ultrasound catheter, it is preferred to connect in a known manner the continuous conducting electrode **44** to a ground line provided by the cable **28**. The ground line runs along the electronics carrier **20** and is connected to the continuous conducting electrode after the electronics body **12** and the transducer assembly **14** have been joined. One possible way to connect the ground wire is shown in FIG. **2** of the Proudian, deceased et al. U.S. Pat. No. 4,917,097.

The transducer elements **22** are enclosed by a matching layer **46**. As explained in *Biomedical Ultrasonics*, by P. N. T. Wells, Academic Press 1977, at page 54, the efficiency of transmission into the load may be increased by an impedance matching layer of quarter wavelength thickness. In the presently preferred embodiment the matching layer **46** comprises a loaded epoxy and is approximately 0.06 mm. thick. Alternative appropriate matching layer materials and their thicknesses will be apparent to those of ordinary skill in the art of ultrasonic imaging.

After independent construction, the electronics body **12** and the transducer assembly **14** are bonded together by a layer of glue **52** and the electrical connections between the electronics body **12** and the transducer assembly **14** are electrically coupled in a manner previously described. The cable **28** containing the leads from the signal processor for the ultrasound catheter (previously described in the Proudian et al. '097 patent) are bonded to the conductive pads **34** on the carrier **20** in a known manner.

FIG. **6** shows an alternative embodiment of the present invention, wherein the imaging device **10** is included in a diagnostic imaging catheter that does not contain a balloon **1**. Portions of the diagnostic imaging catheter have been removed to reveal the cable **28** and the lumen **2**. Since there is no balloon **1** in the imaging catheter shown in FIG. **6**, there is of course no tube **26** for filling and draining a fluid from the balloon. Instead, the catheter is fitted with a nose cone **25**. The nose cone **25** provides a blunted lead surface for the

ultrasound imaging catheter in order to prevent damage to the walls of a cavity as the catheter is inserted. A sheath **38** covers the epoxy resin **8** thereby guarding against contamination of a patient's blood and possibly electrical shock. The sheath **38** is preferably constructed of parylene, though other suitable substitutes will be known to those skilled in the art of medical instruments that are inserted within a body. The structure of the imaging catheter shown in FIG. 6 is otherwise unchanged from the structure of the balloon angioplasty ultrasound imaging catheter illustrated in FIG. 1.

Though the preferred embodiment of the present invention contains a transducer array configured as a cylinder about a cylindrical core, there are numerous other configurations of ultrasound catheters that embody the present invention. Examples of such configurations are shown in FIGS. 7 and 8. Other configurations of transducer arrays for an ultrasound catheter will be known to those skilled in the art in view of the present description of this invention.

FIGS. 7A and 7B illustrate side and cross-sectional views of a side-looking linear array imaging catheter. In this arrangement the transducer elements **22** are arranged in a plane and perpendicular to the direction of insertion of the imaging catheter. This arrangement provides an image along the length of a cavity. In this alternative embodiment of the present invention, the IC's **18** are connected to the cable **28** in the same manner as the previously described embodiments of the invention. Furthermore, in accordance with the present invention, the IC's **18** are mounted upon an electronics carrier **20** of the type previously described in connection with the preferred embodiment of the invention shown in FIG. 1. The IC's are electrically coupled to the transducer elements **22** by conductor lines **30**. The backing material for the transducer elements **22** forms the encapsulant **8** in this case.

FIGS. 8A, 8B and 8C illustrate side, forward, and top cross-sectional views of a forward-looking "endfire" imaging catheter shown in FIG. 1. In FIGS. 8A, 8B and 8C the encapsulant **8**, which is also the backing material for the transducers **22**, has been partially removed to reveal the placement and orientation of the electronics portion. In this arrangement the transducer elements **22** are arranged as a planar array mounted upon the leading face of the catheter. The guide wire lumen **4** is mounted adjacent the ultrasonic imaging device. The diameter of the guide wire lumen **4** is approximately 0.3 mm or about one-third the diameter of the imaging catheter.

This arrangement provides a forward looking view of a cavity. The dimensions of the field of view are determined by the size of the array, the number of elements, the element dimensions and frequency. In this alternative embodiment of the present invention, the IC's **18** are connected to the cable **28** in the same manner as the previously described embodiments of the invention. Furthermore, in accordance with the present invention, the IC's **18** are mounted upon a carrier **20** of the type previously described in connection with the preferred embodiment of the invention shown in FIG. 1. The IC's are electrically coupled to the transducer elements **22** by conductor lines **30**. The encapsulant **8** may form the backing material for the transducer elements **22**.

It will be appreciated by those skilled in the art that modifications to the foregoing preferred embodiment may be made in various aspects. The present invention is set forth with particularity in the appended claims. It is deemed that the spirit and scope of that invention encompasses such modifications and alterations to the preferred embodiment as would be apparent to one of ordinary skill in the art and familiar with the teaching of the present application.

What is claimed is:

1. A method of making an ultrasound transducer assembly, said method comprising the steps of:

manufacturing a planar sheet comprising an array of ultrasound transducer elements and a substrate, the substrate forming a matching layer; and

reshaping the planar sheet into a substantially cylindrical shape.

2. A method as defined in claim 1, wherein the reshaping step causes the substrate to be located at the outside of the array of ultrasound transducer elements.

3. A method as defined in claim 1, further comprising the step of:

electrically coupling at least one integrated circuit to the ultrasound transducer elements.

4. A method as defined in claim 3, wherein the at least one integrated circuit is comprised of an inverted chip design.

5. A method as defined in claim 3, further comprising the step of:

providing an electronics carrier for supporting the at least one integrated circuit.

6. A method of making an imaging catheter, comprising the steps of:

forming a catheter shaft;

attaching an ultrasound transducer assembly to the catheter shaft, the ultrasound transducer assembly formed by the steps of:

manufacturing a planar sheet comprising an array of transducer elements and a substrate, the substrate forming a matching layer; and

reshaping the planar sheet into a substantially cylindrical shape.

7. A method as defined in claim 6, further comprising the step of: attaching a balloon to the catheter shaft.

8. A method as defined in claim 6, wherein the reshaping step causes the substrate to be located at the outside of the array of transducer elements.

9. A method as defined in claim 6, further comprising the step of:

providing an electronics carrier for supporting at least one integrated circuit that is electrically coupled to the set of transducer elements.

10. A method as defined in claim 9, wherein the at least one integrated circuit is comprised of an inverted chip design.

11. An ultrasound transducer assembly comprising:

an ultrasound transducer array including an array of ultrasound transducer elements;

a substrate layer comprising a pliable sheet material formed into a substantially cylindrical shape, the substrate layer forming a matching layer and providing a platform to which the ultrasound transducer elements are fixed.

12. An ultrasound transducer assembly as defined in claim 11 further comprising an electronics carrier for supporting at least one integrated circuit that is electrically coupled to the array of transducer elements.

13. An ultrasound transducer assembly as defined in claim 12 wherein the at least one integrated circuit is of an inverted chip design.

14. An ultrasound transducer assembly as defined in claim 11 wherein the substrate layer is located outside of the transducer elements.

|                |  |         |            |
|----------------|--|---------|------------|
| 专利名称(译)        | 超声换能器组件  |         |            |
| 公开(公告)号        | <a href="#">US6962567</a>  | 公开(公告)日 | 2005-11-08 |
| 申请号            | US09/906302  | 申请日     | 2001-07-16 |
| [标]申请(专利权)人(译) | EBERLE MICHAEL J<br>RIZZUTI GARY P<br>KIEPEN HORST F   |         |            |
| 申请(专利权)人(译)    | EBERLE 迈克尔 J.<br>RIZZUTI GARY P.<br>KIEPEN HORST F.  |         |            |
| [标]发明人         | EBERLE MICHAEL J<br>RIZZUTI GARY P<br>KIEPEN HORST F   |         |            |
| 发明人            | EBERLE, MICHAEL J.<br>RIZZUTI, GARY P.<br>KIEPEN, HORST F.   |         |            |
| IPC分类号         | A61B8/12 G10K11/00 A61B8/06 A61B8/14 B06B1/02 B06B1/06 G01S15/89   |         |            |
| CPC分类号         | A61B8/06 A61B8/4483 A61B8/4488 B06B1/0633 B06B1/067 B06B1/0674 G01S15/892 G01S15/8979 G01S15/899 G10K11/004 G10K11/008 A61B8/12 Y10T29/42 A61B8/445 B06B2201/76 G01S15/8981 A61B8/4494 |         |            |
| 其他公开文献         | US20010041842A1  |         |            |
| 外部链接           | <a href="#">Espacenet</a> <a href="#">USPTO</a>  |         |            |

摘要(译)

公开了一种超声导管，用于提供小腔的基本上实时的图像。超声导管的特征在于分离且不同的材料，用于支撑换能器和承载电子元件。单独的材料包括满足保持超声装置的集成电路的要求的电子载体和显示与减少振铃和最小化换能器组件中的其他信号劣化源的影响有关的优良特性的背衬材料。而且，根据本发明，描述了一种用于连接单独的换能器组件和电子设备主体的导线的技术。

