



(19) **United States**

(12) **Patent Application Publication**
Marmarelis

(10) **Pub. No.: US 2003/0171677 A1**

(43) **Pub. Date: Sep. 11, 2003**

(54) **MULTI-MODE PROCESSING FOR
ULTRASONIC IMAGING**

Publication Classification

(75) **Inventor: Vasilis Z. Marmarelis, Irvine, CA (US)**

(51) **Int. Cl.⁷ A61B 8/00**

(52) **U.S. Cl. 600/441**

Correspondence Address:
McDERMOTT, WILL & EMERY
Suite 3400
2049 Century Park East
Los Angeles, CA 90067-3208 (US)

(57) **ABSTRACT**

(73) **Assignee: Alfred E. Mann Institute for Biomedical Engineering at the University of Southern**

Systems and methods for obtaining images of body organs or other tissue for each of their multiple characterizing aspects, and for classifying different tissue types within the images according to their characterizing aspects, are disclosed herein. The tissue may be irradiated with an ultrasonic signal, and an interaction signal received in return. Sinogram data may be constructed from the received interaction signal, and multiple characterizing data extracted therefrom. The multiple characterizing data representing multiple characterizing aspects may then be matched to tissue type within a database containing information correlating characterizing multi-aspect data with tissue type. Images of the tissue may then be presented with identifiers associating tissue portions with their matched tissue types.

(21) **Appl. No.: 10/382,235**

(22) **Filed: Mar. 5, 2003**

Related U.S. Application Data

(60) **Provisional application No. 60/362,568, filed on Mar. 6, 2002.**

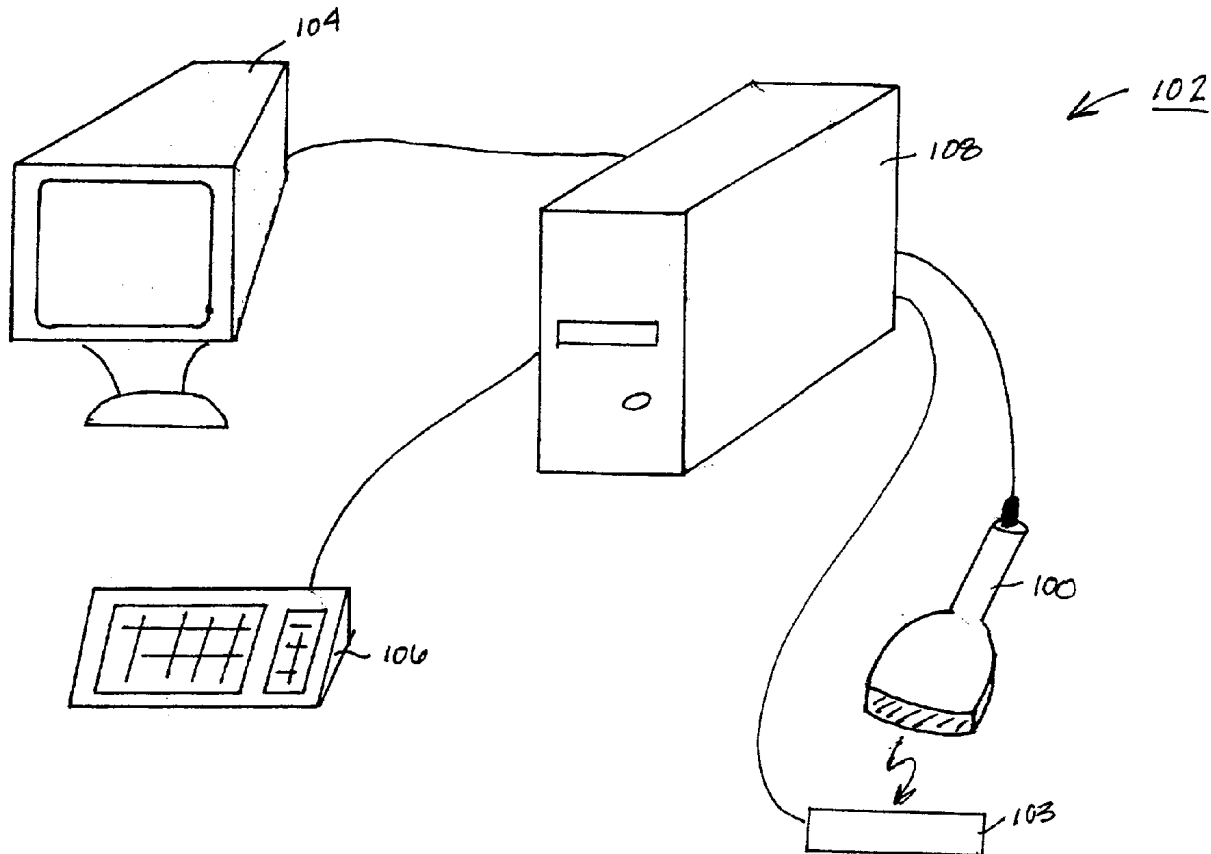

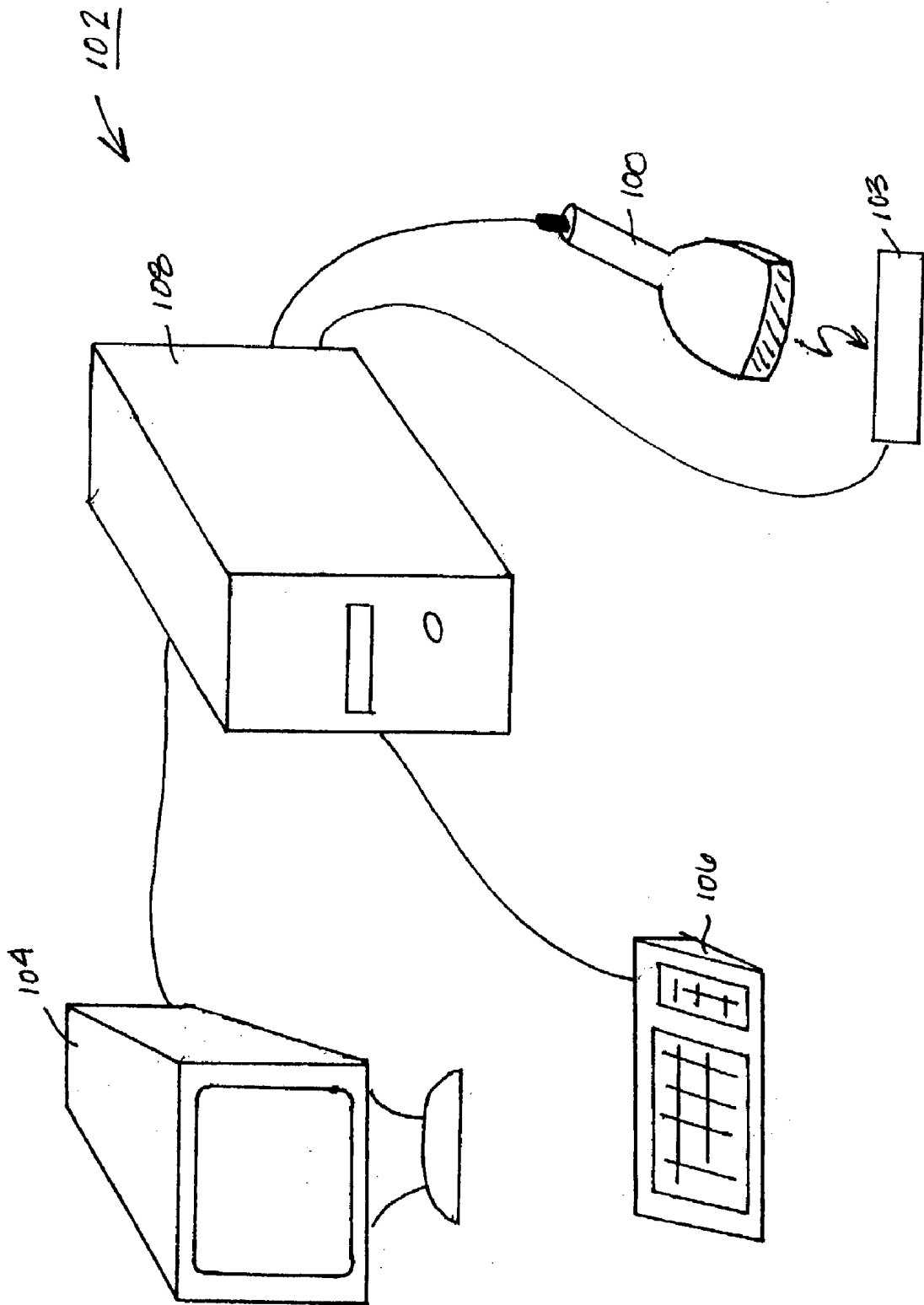

FIG. 1

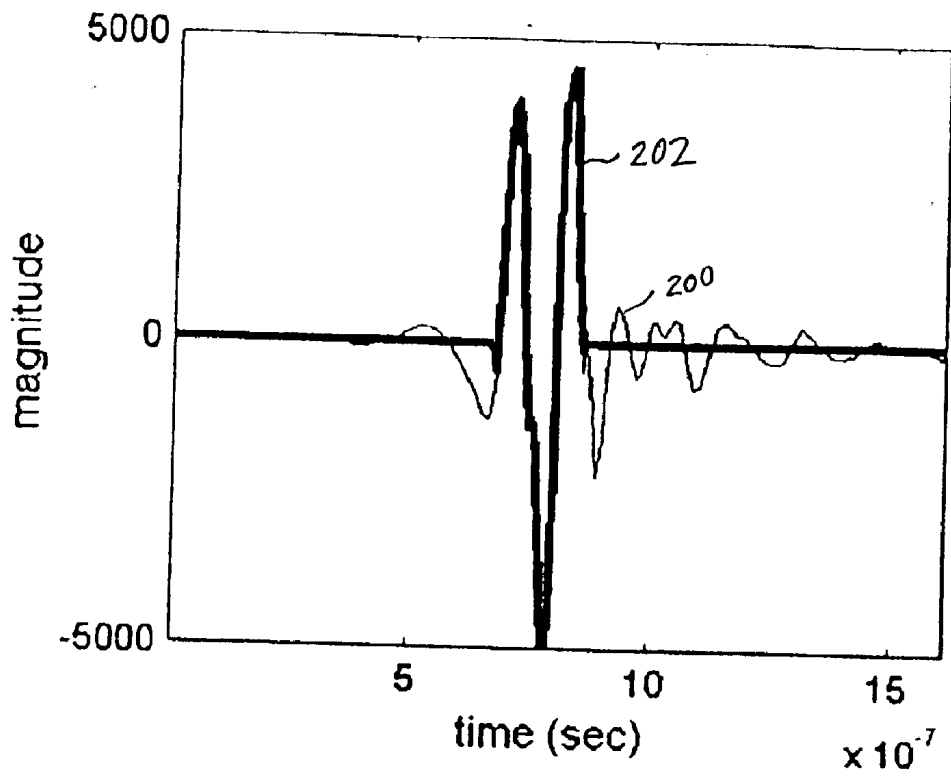

FIG. 2

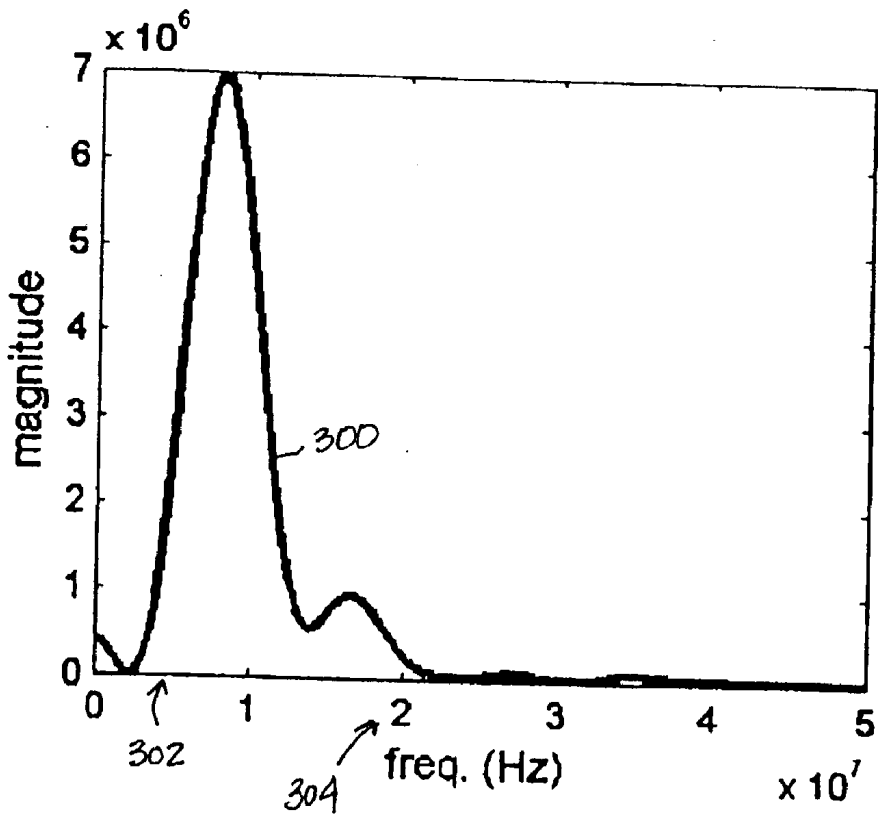

FIG. 3

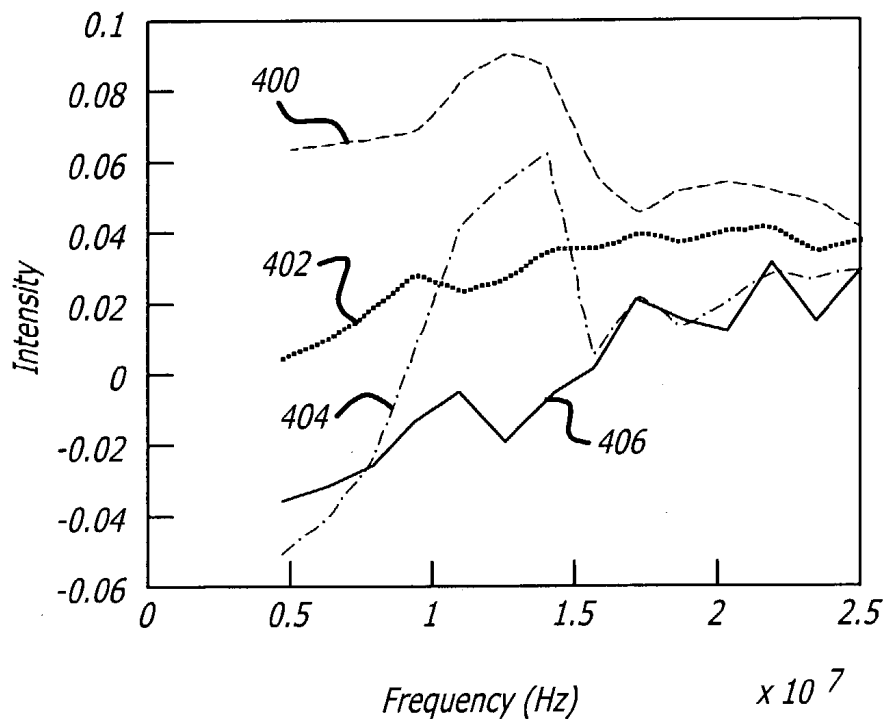

FIG. 4

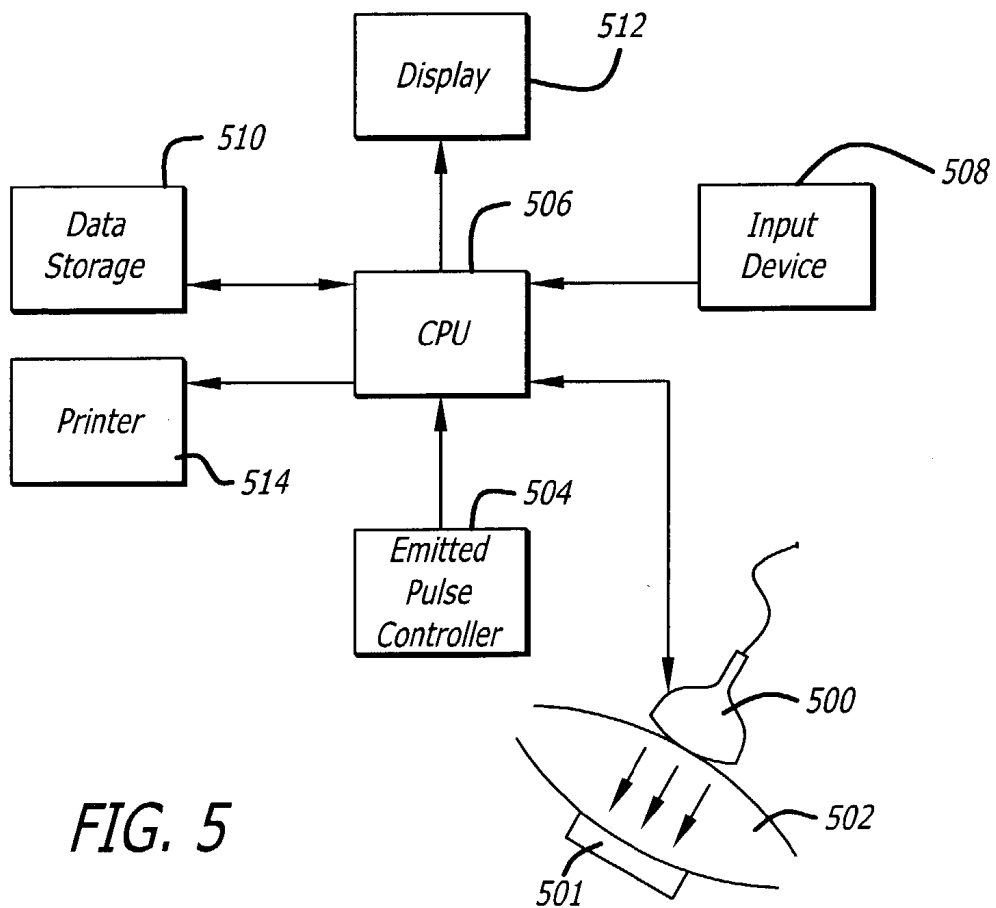

FIG. 5

MULTI-MODE PROCESSING FOR ULTRASONIC IMAGING

CROSS REFERENCE TO RELATED APPLICATION

[0001] This application is related to and claims the benefit of the filing date of U.S. provisional application Serial No. 60/362,568, filed Mar. 6, 2002, entitled "Multi-Mode Processing for Ultrasonic Imaging," the contents of which are incorporated herein by reference.

BACKGROUND OF THE INVENTION

[0002] 1. Field of the Invention

[0003] The invention relates to imaging of body organs and tissues. The invention also relates to systems and methods for classifying tissue types.

[0004] 2. General Background and State of the Art

[0005] Ultrasound has been a popular medical imaging technique for many years. Ultrasonic imaging typically involves measurements of a single acoustic parameter by transmitting an acoustic signal into a tissue and analyzing the response. For example, reflectivity coefficients may be used to generate reflection images, and attenuation or time-of-flight data may be used to generate transmission images. Sinogram data can be derived from multiple measurements of the acoustic parameter, from which a single-parameter image can be subsequently generated. Such images might be used to visualize a developing baby or circulation of blood, for example.

[0006] However, these single-parameter imaging methods are not always sufficient for classifying various types of tissue within an imaged tissue portion. One reason is that such methods typically involve measuring the acoustic parameter, such as attenuation, from peak amplitude values or from total energy of the received. Because ultrasonic signals commonly experience errors of up to 10%, the captured image data often is not sufficiently accurate to classify tissue types accurately. Even time of flight-based imaging has its tissue type classification potential hindered due to frequency-dependent dispersion effects of ultrasonic propagation in tissues that comprise nonlinear inhomogeneous propagation medium. There currently are not known methods for accurately classifying portions of a tissue sample according to tissue type through enhancement of a single acoustic parameter of the tissue sample.

INVENTION SUMMARY

[0007] The present invention helps solve these and other problems by providing methods and systems for classifying different tissue types through enhancement of a single acoustic trait by extracting multiple aspects therefrom.

[0008] In one embodiment, a method for classifying a tissue that is irradiated with an ultrasonic signal includes receiving an interaction signal resulting from the interaction between the ultrasonic signal and at least one portion of the tissue, extracting at least first and second characterizing data from an initial portion of the interaction signal characterizing at least a first and second aspect, respectively, of the initial portion of the interaction signal, the first aspect being different from the second aspect, calculating first and second

identification data as a function of the first and second characterizing data, respectively, and matching the first and second identification data to a tissue type by consulting a database containing information correlating identification data associated with at least the first and second aspects to tissue type.

[0009] In another embodiment, a method for classifying a tissue that is irradiated with an ultrasonic signal includes receiving an interaction signal resulting from the interaction between the ultrasonic signal and at least one portion of the tissue; performing a Fourier transform on an initial portion of the interaction signal, and calculating a characteristic of the tissue portion as a function of the Fourier transform of the initial portion of the interaction signal.

[0010] In a further embodiment, a system for performing a method of classifying a tissue that is irradiated with an ultrasonic signal includes a transmission element for irradiating a portion of the tissue with an ultrasonic signal, a receiver element for subsequently receiving an interaction signal resulting from an interaction between the radiated ultrasonic signal and the tissue portion, and a data storage device for storing a database containing information correlating identification data of first and second tissue aspects with tissue type. The system further includes a processor operatively connected to the receiver element and configured to process the interaction signal and extract at least first and second characterizing data therefrom, the characterizing data characterizing at least a first and second aspect, respectively, of an initial portion of the interaction signal. The processor is further configured to calculate identification data as a function of the characterizing data, the identification data representative of at least first and second aspects of the tissue portion. The processor is operatively connected to the data storage device, and further configured to match the identification data to a tissue type by consulting the tissue type database.

[0011] In yet another embodiment, a system for classifying a tissue that is irradiated with an ultrasonic signal includes a transmission element for irradiating a portion of the tissue with an ultrasonic signal and a receiver element for subsequently receiving an interaction signal resulting from an interaction between the radiated ultrasonic signal and the tissue portion. A processor is operatively connected to the receiver element and configured to process the interaction signal and identify the initial portion thereof, perform a Fourier transform on the initial portion of the interaction signal, and calculate a characteristic of the tissue portion as a function of the Fourier transform.

[0012] The foregoing and other objects, features, and advantages of the present invention will become apparent from a reading of the following detailed description of exemplary embodiments thereof, in conjunction with the accompanying drawing Figures.

BRIEF DESCRIPTION OF THE DRAWINGS

[0013] FIG. 1 illustrates an exemplary system for classifying a tissue that is irradiated with an ultrasonic signal;

[0014] FIG. 2 illustrates an exemplary initial portion of an interaction signal resulting from interaction with a tissue to be classified;

[0015] FIG. 3 illustrates a graphical representation of a plurality of characterizing data extracted from an initial portion of an interaction signal;

[0016] FIG. 4 illustrates a graphical representation of tissue type characteristics; and

[0017] FIG. 5 is a block diagram of various components within an exemplary system for classifying a tissue that is irradiated with an ultrasonic signal.

DETAILED DESCRIPTION OF THE PREFERRED EMBODIMENTS

[0018] FIG. 1 illustrates an exemplary system for classifying a tissue that is irradiated with an ultrasonic signal. In the classification process, various portions of the tissue may be differentiated to detect lesions or cancerous portions from normal portions according to differences in characteristics of the tissues. A differentiation technique utilized by the exemplary system analyzes differences in the attenuation characteristics of various types of tissues at different frequencies. A propagating ultrasonic pulse emitted by an ultrasonic imaging system undergoes frequency-dependent attenuation according to the type of material it traverses. Therefore, attenuation or other characteristics of an ultrasonic pulse radiating into a tissue may be measured and processed according to the methods disclosed herein for the purpose of characterizing portions of the tissue to differentiate between various tissue types.

[0019] In one embodiment, the system may include a transmission-mode ultrasound machine 102 for emitting an ultrasonic signal into a tissue to be classified, receiving the forward-scattering signal in a modified form as an interaction signal after the emitted ultrasonic signal has interacted with the tissue, and subsequently processing the interaction signal to classify the portion of the tissue it interacted with. A transmitting element 100 or array of transmitting elements may send high-frequency signals, such as 1 to 10 megahertz sound pulses, into the tissue to be tested. The sound waves travel into the tissue and interact therewith, experiencing modifications that may include frequency-dependent signal attenuation. The interaction signal is then received by receiver element 103 or an array of receiver elements, and relayed to ultrasound machine 102 for processing. In an alternative embodiment employing an angle-mode ultrasound machine that measures angle scattering, the propagated signal may scatter within an approximately 60 degree range of transmission or zero degree forward scattering. The angle scattered sound waves may then be received by receiver element 103 and relayed to ultrasound machine 102. Ultrasound machine 102 may also comprise a high resolution ultrasonic transmission tomography (HUTT) system, such as that disclosed in an article entitled "High Resolution Ultrasonic Transmission Tomography" by Marmarelis, et. al., published for *SPIE International Symposium, Medical Imaging* in February, 2003 and incorporated herein by reference. Ultrasound machine 102 may alternatively include echo-mode imaging systems, transmission-mode ultrasound computed tomography (UCT) systems or other imaging systems.

[0020] Continuing the description with reference to a transmission-mode system, which includes a transmitting element 100 for transmitting a signal and receiver element 103 for receiving a interaction signal, ultrasound machine 102 may further include a display 104, a user input device 106 and a computer 108. The various components of ultrasound machine 102 may be separate, connectable compo-

nents as illustrated in FIG. 1, or may be contained within a single device. User input device 106 may be used to provide information to computer 108, such as control information regarding the amplitude, frequency and duration of pulses emitted from transmitting element 100. Computer 108, upon receipt of a transmitted sound wave, which has been altered to become an interaction signal as a result of its interaction with the tissue, may then process that interaction signal to determine information about the tissue. For example, computer 108 may extract attenuation information across multiple frequency bands in the interaction signal, as will be described in further detail below. Other information that may be utilized for tissue classification in an alternative embodiment may include "time of flight," which may be measured as the time it takes each sound wave to travel from transmitting element 100 to receiver element 103, typically on the order of millionths of a second. Display 104 may present an image of the measured acoustic traits of the interaction signal, forming a two dimensional image of the tissue. Display 104 may present additional identification information to supplement the displayed image, indicating tissue type classification. The tissue type classification processing and identification will be described in further detail below.

[0021] In an exemplary embodiment, a transmission-mode system may be utilized to perform a tomographic scan that includes azimuthal and angular scans of the tissue using a pair of sub-millimeter transmitting and receiving transducer elements, such as piezoelectric crystals having dimensions of approximately 0.4 mm by 0.4 mm. The transducer elements may be arranged in multi-element transmitter and receiver arrays, and the tomographic scan may be performed in parallel-beam transmission mode, with the system operating at approximately 8 MHz center frequency. Exemplary settings for a tomographic scan may include an azimuthal step of 0.4 mm, a vertical elevation of 0.4 mm and an angular step of 0.5 degrees. Of course, these values are merely illustrative, and it is to be understood that other values that will be readily ascertainable by those skilled in the art are contemplated as being within the scope of the present invention. The tomographic scans produce a plurality of interaction signals that collectively form sinogram data representing a portion of the tissue that is scanned. Depending on the arrangement of the transducer and receiving elements, an interaction signal generated by a scan may represent a single pixel within an image of the tissue portion, a line of pixels, or another multi-pixel configuration.

[0022] FIG. 2 illustrates an exemplary initial portion of an interaction signal resulting from interaction with a tissue to be classified. In one embodiment, the initial portion of the interaction signal is extracted from the totality of received signals for selective analysis. For example, the first arrival pulse, which does not include contributions from later arriving pulses, may be detected and extracted from the received signal. A plurality of extracted first arrival pulses collectively form sinogram data for a portion of the tissue being scanned. The tissue portion may be represented by a single line within an image, representing a line of pixels, or another pixel configuration depending on the arrangement of the transmitting elements and the configuration of the scan. Regardless of the size of the scanned tissue portion, each extracted first arrival pulse may then be processed to yield a multispectral vector of attenuation values at multiple frequency bands.

[0023] In the exemplary embodiment, interaction signal **200** is relayed from a receiving element or receiving array to a processor that will isolate an initial portion of the interaction as the first-arrival pulse of the received interaction signal for analysis. To perform the first-arrival pulse extraction, a filter may be applied to signal **200**. The filter may include a threshold determined by the ambient noise level and based on testing and statistical analysis of typical received interaction signals. Then the filter, which may accordingly specify time from left to right, may be applied to signal **200** in order to extract first arrival pulse **202**. This process may be repeated such that arrival pulse **202** is extracted at each azimuthal and angular location of a mechanical tomographic scanner in transmission mode. The resultant plurality of first arrival pulses **202** collectively form a two dimensional sinogram of the tissue portion when plotted as azimuthal v. angle components. Each first arrival pulse **202** may then be individually processed to extract a plurality of characterizing data from each. The characterizing data, once extracted, are represented in a domain other than the time domain of the first arrival pulse. The characterizing data of the alternative domain may then establish a third dimension within a three dimensional sinogram. For example, in the case that the pertinent aspect is attenuation at multiple spectral bands, the third dimension of the three dimensional sinogram would be defined by frequency, as extracted through processing the first arrival pulse **202**. An exemplary processing algorithm is a discrete Fourier transform, in which the overall spectral width of first arrival pulses **202** is divided into discrete spectral bands. The extraction of characterizing data from the first arrival pulses **202** data may thus form a stack of two dimensional sinograms, with the stack representing a three dimensional sinogram whose third dimension is defined by the spectral bands extracted through the Fourier transform.

[0024] FIG. 3 illustrates a graphical representation of a plurality of characterizing data **300** extracted from the first portion of an interaction signal. Various types of characterizing data may include attenuation values at multiple frequency bands, phase shifts at multiple frequency bands, time-of-flight values, wavelet decomposition coefficients and the like. Characterizing data **300** may also be extracted through different processing algorithms. For example, a Discrete Fourier Transform on the extracted first arrival pulse may yield discrete values of attenuation at each of a plurality of frequency bands. Characterizing data **300** is thus represented by a curve fit to a plurality of discrete values generated by a Fourier Transform algorithm as applied to an extracted first arrival pulse. The Fourier Transform algorithm may be applied to generate characterizing data for any number of frequency bands. For example, in the case of 20 spectral bands between 5 MHz, represented at point **302**, and 20 MHz, represented at point **304**, data **300** would comprise discrete values for attenuation at 0.75 MHz intervals. However, it is understood that the number of spectral bands utilized for the processing methods disclosed herein is not limited to 20, and that any multiple number of spectral bands may be used to extract a plurality of characterizing data from a first arrival pulse in accordance with the teachings of the present invention. Also, characterizing data may be generated by normalizing the Fourier transform with the Fourier transform of an interaction signal generated by transmitting an ultrasonic signal through water. That is, the Fourier transform from which characterizing data are extracted may

comprise a ratio of the Fourier transform of a tissue-based interaction signal to the Fourier transform of a water-based interaction signal.

[0025] Once extracted from an interaction signal, a plurality of one type of characterizing data may define a multi-characteristic vector. The multi-component vector represents attenuation at multiple frequency bands in a single pixel of an image representing the tissue. In turn, a plurality of vectors may form a three dimensional sinogram representing a three-dimensional image of the received interaction signal. The three dimensional sinogram represents a line of pixels within the image, measured by the transducer at a given angle in the imaging plane at varying distances along the detector array. The intensity of the pixels represents attenuation of the signal caused by interaction with the tissue portion it passed into. The frequency-dependent attenuation can be obtained as the ratio of the frequency spectrum of the signal entering each tissue portion represented in a resultant image by a single pixel, to the spectrum of the forward-scattered interaction signal. Therefore, the received interaction signal comprises a modified ultrasonic wave traversing a line of pixel-represented tissue portions and thus represents a single line within an image of the tissue portion.

[0026] After performing a Fourier Transform on each interaction signal to extract multi band characterizing data as described above, image reconstruction is accomplished by applying filtered back-projection algorithms to the data in each of the extracted spectral bands. Applicable filtered back-projection algorithms for image reconstruction will be readily apparent to those skilled in the art. Applying the filtered back-projection algorithms to each of the two-dimensional sinograms that are components of the three-dimensional sinogram achieved by the Fourier Transforms above results in a stack of images representing a three dimensional multi-band augmentation of a two dimensional tomographic slice, wherein the third dimension is represented by the plurality of spectral bands extracted through the Fourier Transform. Thus, the multispectral image representation contains multi-band identification data of individual pixels that can be used for tissue classification of the tissue portions, such that tissue portions may be distinguished according to various tissue types. Isolation of multi-band identification data of individual pixels from a three dimensional image may, in some embodiments, include spectral unmixing techniques as described in an article titled "Multi-band Tissue Differentiation in Ultrasonic Transmission Tomography" by Marmarelis et. al., published for *SPIE International Symposium, Medical Imaging* in February 2003, incorporated herein by reference.

[0027] FIG. 4 illustrates a graphical representation of known tissue type characteristics. After the multi-band characteristics of individual pixels are isolated, the resultant multi-characteristic vector may be compared to the known tissue type characteristics. Each data set **400**, **402**, **404** and **406** represents a multi-characteristic vector of a different tissue type, identified through laboratory testing. For example, in breast imaging applications, tissue types for which known multi-characteristic vectors would be stored in a database for comparison with tested breast tissue portions may include normal tissue, fat, blood vessels, mammary ducts, benign lesions, malignant lesions, microcalcifications, lobules, cysts, and other tissue types. Known multi-characteristic vectors for each of the various tissue types may be

developed in accordance with the methods described above and stored in a database for comparison with extracted multi-characteristic vectors of unknown tissue portions to classify them as to tissue type. For example, characterizing data may be processed and determined for a tissue portion of unknown tissue type, then compared with a multi-characteristic vector database containing information correlating characterizing data of multiple aspects with tissue type. In the case of multiple aspects comprising attenuation in multiple frequency bands, known multi-characteristic vectors represented by data sets **400**, **402**, **404** and **406** represent the known attenuation at certain frequency bands in each of a different type of tissue. Then, a tissue portion of unknown tissue type may be analyzed according to the methods described above, and have a multi-characteristic vector constructed according to its measured and analyzed attenuation at the same frequency bands as those included in data sets **400**, **402**, **404** and **406**. Finally, the multi-characteristic vector of the tissue portion of unknown tissue type may be compared to the multi-characteristic vectors represented by stored data sets **400**, **402**, **404** and **406**, wherein a substantial match is indicative of the tissue type of the analyzed tissue portion.

[**0028**] **FIG. 5** is a block diagram of various components within an exemplary system for classifying a tissue that is irradiated with an ultrasonic signal. Emitter array **500** irradiates tissue **502** with an ultrasonic signal. Various characteristics of the ultrasonic signal may be controlled by a user through emitted pulse controller **504**, which is operatively connected to a central processing unit (CPU) **506**. CPU **506** may also receive other user input through a user input device **508** such as a keyboard, mouse, tracking ball, or other similar device. An interaction signal, changed as a result of interaction with tissue **502**, is received by emitter array **500** and relayed to CPU **506** where it is processed and analyzed as described above. Data storage **510** may contain multi-characteristic vectors of known tissue types for comparison with an analyzed multi-characteristic vector of tissue **502**, to distinguish between various tissue types of tissue portions therein. The classification of various portions of tissue **502** may be reported to a user in various ways including imaging on a display **512**. The tissue **502** may be represented in an image, with its classified tissue portions represented by varying colors or shades according to tissue type. Alternatively, various tissue types may be reported to a user by printing characterizing data of tissue portions through printer **514**. Of course, other reporting methods are possible as well.

[**0029**] While the specification describes particular embodiments of the present invention, those of ordinary skill can devise variations of the present invention without departing from the inventive concept. The foregoing description of particular embodiments of the invention has been presented for the purposes of illustration and description. It is not intended to be exhaustive or to limit the invention to the precise form disclosed. Many modifications and variations are possible in light of the above teaching. For example, the extraction of multi-aspect characterizing data from a portion of sinogram data, such as by performing a Fourier Transform, may be performed on an individual pixel rather than on a line of pixels represented by the sinogram data portion. Also, other extraction algorithms may be utilized instead of the Fourier Transform. For example, wavelet decomposition, principal component

analysis, independent component analysis and other types of signal decomposition known in the art may be performed to extract multi-aspect characterizing data from the sinogram data. Moreover, multi-aspect characterizing data is not limited to data representing multiple spectral bands; rather, it may include other components of the sinogram data such as phase shift components that may be extracted with Fourier Transforms, decomposition, or other processing algorithms. Further, multi-characteristic vectors representing the multi-characteristic data of a tissue portion may include time of flight or other information.

I claim:

1. A method for classifying a tissue that is irradiated with an ultrasonic signal comprising:

- a) receiving an interaction signal resulting from the interaction between the ultrasonic signal and at least one portion of the tissue;
- b) extracting at least first and second characterizing data from an initial portion of the interaction signal characterizing at least a first and second aspect, respectively, of the initial portion of the interaction signal, the first aspect being different from the second aspect;
- c) calculating first and second identification data as a function of the first and second characterizing data, respectively; and
- d) matching the first and second identification data to a tissue type by consulting a database containing information correlating identification data associated with at least the first and second aspects to tissue type.

2. The method of claim 1, wherein the first and second aspects comprise attenuation in the initial portion of the interaction signal in first and second frequency bands, respectively, the attenuation being caused by the interaction between the ultrasonic signal and the tissue portion.

3. The method of claim 1 wherein the extraction of characterizing data from the initial portion of the interaction signal comprises performing a Fourier transform on the initial portion of the interaction signal.

4. The method of claim 1, further comprising displaying an image of the tissue portion including an identifier to report the matched tissue type of the tissue portion.

5. The method of claim 1 wherein the initial portion of the interaction signal is representative of an interaction between the ultrasonic signal and a segment of the tissue portion represented by a line of pixels in an image of the tissue portion.

6. The method of claim 1 wherein the receiving an interaction signal is repeated a plurality of times each from a different perspective of the tissue portion, the extraction of characterizing data is performed for each of the plurality of received interaction signals, and the calculation of identification data is a function of the combined plurality of extracted characterizing data.

7. A method for classifying a tissue that is irradiated with an ultrasonic signal comprising:

- a) receiving an interaction signal resulting from the interaction between the ultrasonic signal and at least one portion of the tissue;
- b) performing a Fourier transform on an initial portion of the interaction signal; and

c) calculating a identification data representing a characteristic of the tissue portion as a function of the Fourier transform of the initial portion of the interaction signal.

8. The method of claim 7 wherein the calculation of identification data comprises applying a filtered back-projection algorithm to a set of data comprising the Fourier transform of the initial portion of the interaction signal.

9. The method of claim 7, wherein the tissue portion characteristic includes first and second aspects of the tissue portion.

10. The method of claim 8, wherein the first and second aspects represent attenuation in the initial portion of the interaction signal in first and second frequency bands, respectively, the attenuation being caused by the interaction between the ultrasonic signal and the tissue portion.

11. The method of claim 8, further comprising matching the identification data to a tissue type by consulting a tissue type database containing information correlating identification data with tissue type.

12. The method of claim 7 wherein the receiving an interaction signal is repeated a plurality of times each from a different perspective of the tissue portion, the performance of a Fourier transform is repeated for each of the plurality of received interaction signals, and the calculation of identification data is a function of the combined plurality of extracted characterizing data.

13. A system for classifying a tissue that is irradiated with an ultrasonic signal comprising:

- a) a transmission element for irradiating a portion of the tissue with an ultrasonic signal;
- b) a receiver element for subsequently receiving an interaction signal resulting from an interaction between the radiated ultrasonic signal and the tissue portion;
- c) a data storage device for storing a database containing information correlating identification data of first and second tissue aspects with tissue type;
- d) a processor operatively connected to the receiver element and configured to process the interaction signal and extract at least first and second characterizing data therefrom, the characterizing data characterizing at least a first and second aspect, respectively, of an initial portion of the interaction signal;
- e) the processor further configured to calculate identification data as a function of the characterizing data, the identification data representative of at least first and second aspects of the tissue portion; and
- f) the processor being operatively connected to the data storage device, and further configured to match the identification data to a tissue type by consulting the tissue type database.

14. The system of claim 13, wherein the first and second aspects comprise attenuation in the initial portion of the interaction signal in first and second frequency bands, respectively, the attenuation being caused by the interaction between the ultrasonic signal and the tissue portion.

15. The system of claim 13 wherein the extraction of characterizing data from the initial portion of the interaction signal comprises the processor further being configured to perform a Fourier transform on the initial portion of the interaction signal.

16. The system of claim 13, further comprising a display device operatively connected to the processor and config-

ured to display an image of the tissue portion including an identifier to report the matched tissue type of the tissue portion.

17. The system of claim 13 wherein the initial portion of the interaction signal is representative of an interaction between the ultrasonic signal and a segment of the tissue portion represented by a line of pixels in an image of the tissue portion.

18. The system of claim 13 wherein the transmission element and receiver element are configured to irradiate an ultrasonic signal and subsequently receive an interaction signal, respectively, a plurality of times each from a different perspective of the tissue portion, the processor is further configured to extract characterizing data from each of the interaction signals, and the processor is further configured to calculate identification data as a function of the combined plurality of characterizing data.

19. A system for classifying a tissue that is irradiated with an ultrasonic signal comprising:

- a) a transmission element for irradiating a portion of the tissue with an ultrasonic signal;
- b) a receiver element for subsequently receiving an interaction signal resulting from an interaction between the radiated ultrasonic signal and the tissue portion;
- c) a processor operatively connected to the receiver element and configured to process the interaction signal and identify the initial portion thereof;
- d) the processor further configured to perform a Fourier transform on the initial portion of the interaction signal; and
- e) the processor further configured to calculate identification data representing a characteristic of the tissue portion as a function of the Fourier transform.

20. The system of claim 19, wherein the tissue portion characteristic includes first and second aspects of the tissue portion.

21. The system of claim 20, wherein the first and second aspects represent attenuation in the initial portion of the interaction signal in first and second frequency bands, respectively, the attenuation being caused by the interaction between the ultrasonic signal and the tissue portion.

22. The system of claim 19, further comprising a data storage device in communication with the processor for storing a database containing information correlating identification data with tissue type.

23. The system of claim 22 wherein the initial portion of the interaction signal is representative of an interaction between the ultrasonic signal and a segment of the tissue portion represented by a line of pixels in an image of the tissue portion.

24. The system of claim 19 wherein the transmission and receiver elements are configured to transmit and receive an ultrasonic signal and an interaction signal, respectively, a plurality of times each from a different perspective of the tissue portion, the processor is further configured to perform the Fourier transform on the initial portion of each of the plurality of received interaction signals, and the processor is further configured to calculate identification data as a function of the combined plurality of Fourier transforms.

专利名称(译)	超声成像的多模处理		
公开(公告)号	US20030171677A1	公开(公告)日	2003-09-11
申请号	US10/382235	申请日	2003-03-05
[标]申请(专利权)人(译)	ALFRED&INST曼生物医学ENG AT南部UNIV		
申请(专利权)人(译)	艾尔弗雷德·E·曼学院生物医学工程AT SOUTHERN大学的		
[标]发明人	MARMARELIS VASILIS Z		
发明人	MARMARELIS, VASILIS Z.		
IPC分类号	A61B8/06 A61B8/08 G06F19/00 A61B8/00		
CPC分类号	A61B8/06 A61B8/0825 A61B8/0858 G06F19/3487 A61B8/15 G06F19/321 G06F19/324 A61B8/0866 G16H15/00		
优先权	60/362568 2002-03-06 US		
其他公开文献	US6776760		
外部链接	Espacenet USPTO		

摘要(译)

本文公开了用于针对其多个特征方面中的每一个获得身体器官或其他组织的图像，以及用于根据图像的特征方面对图像内的不同组织类型进行分类的系统和方法。可以用超声信号照射组织，并且反过来接收相互作用信号。可以从接收的交互信号构造正弦图数据，并从中提取多个特征数据。然后，可以将表示多个表征方面的多个表征数据与包含将多方面数据与组织类型表征相关的信息的数据库内的组织类型进行匹配。然后可以呈现组织的图像，其具有将组织部分与其匹配的组织类型相关联的标识符。

