



(19) **United States**

(12) **Patent Application Publication**

**Lin et al.**

(10) **Pub. No.: US 2004/0127795 A1**

(43) **Pub. Date:**

**Jul. 1, 2004**

(54) **METHOD OF ULTRASONIC SPECKLE REDUCTION USING WIDE-BAND FREQUENCY COMPOUNDING WITH TISSUE-GENERATED HARMONICS**

(75) Inventors: **Feng Lin**, Waukesha, WI (US); **Satchi Panda**, Greenfield, WI (US); **Richard Yung Chiao**, Menomonee Falls, WI (US)

Correspondence Address:  
**JOSEPH S. HEINO, ESQ.**  
111 E. KILBOURN AVENUE  
SUITE 1400  
MILWAUKEE, WI 53202 (US)

(73) Assignee: **GE Medical Systems Global Technology Company, LLC**, Waukesha, WI

(21) Appl. No.: **10/335,277**

(22) Filed: **Dec. 31, 2002**

**Publication Classification**

(51) **Int. Cl.<sup>7</sup> ..... A61B 8/00**

(52) **U.S. Cl. .... 600/443**

(57) **ABSTRACT**

A method and apparatus for smoothing speckle pattern and increasing contrast resolution in ultrasound images is provided. Compared to other frequency compounding techniques, wide-band harmonic frequency compounding reduces speckle noise without sacrificing the resolution. Compared to spatial compounding, wide-band harmonic frequency compounding is more robust against tissue motion because sequential vectors rather than frames are summed together for compounding. The method and apparatus is implemented by transmitting two or more firings, combining two or more of the firings coherently to extract the tissue-generated harmonic components, detecting the outputs of the coherent sums and detecting one or more firings before coherent sum, and finally combining all detected outputs to form the compounded image. The method and apparatus sums wide-band fundamental and wide-band harmonic images after detection to form a compounded image. Unlike other frequency compounding methods, both transmit and receive signals are wide-band and no narrow-band filters are necessary. Multiple firings with two or more different transmit waveforms are transmitted to each focal zone.

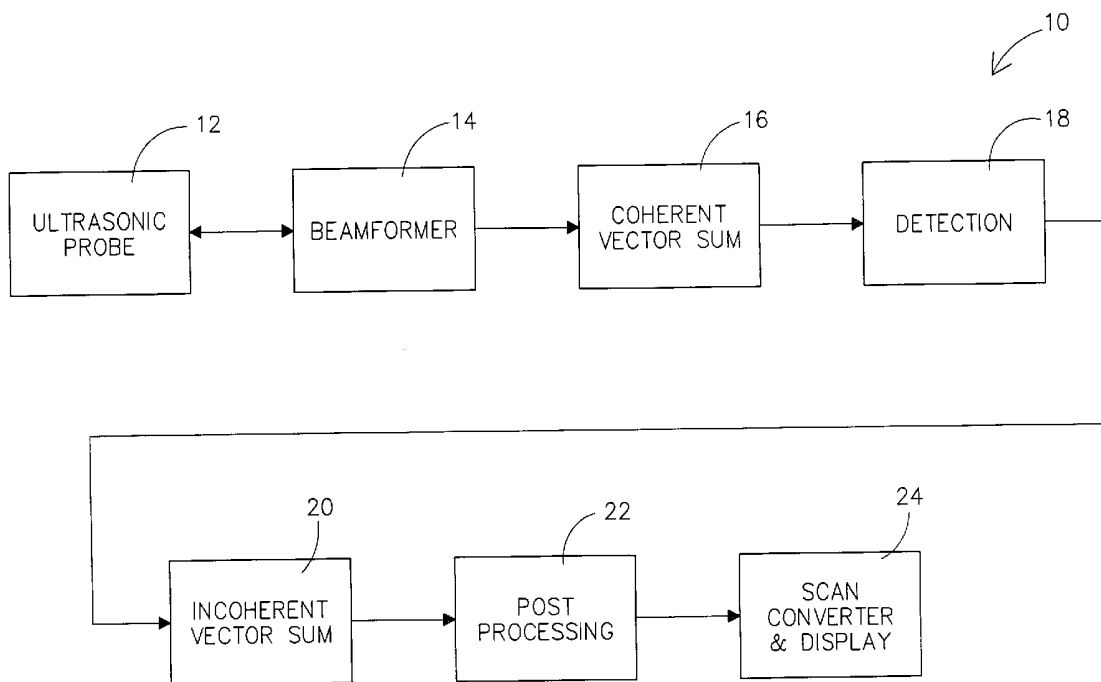

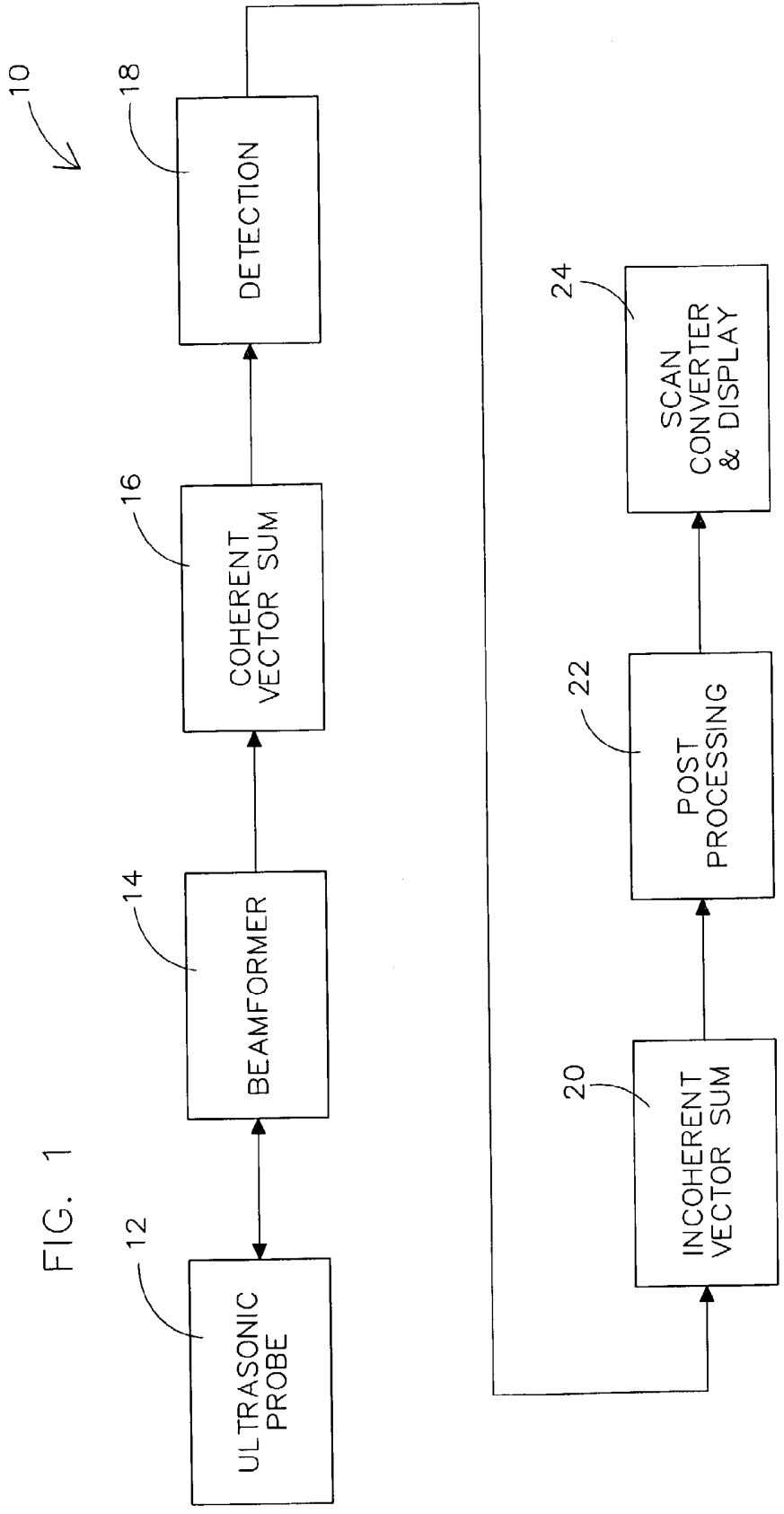

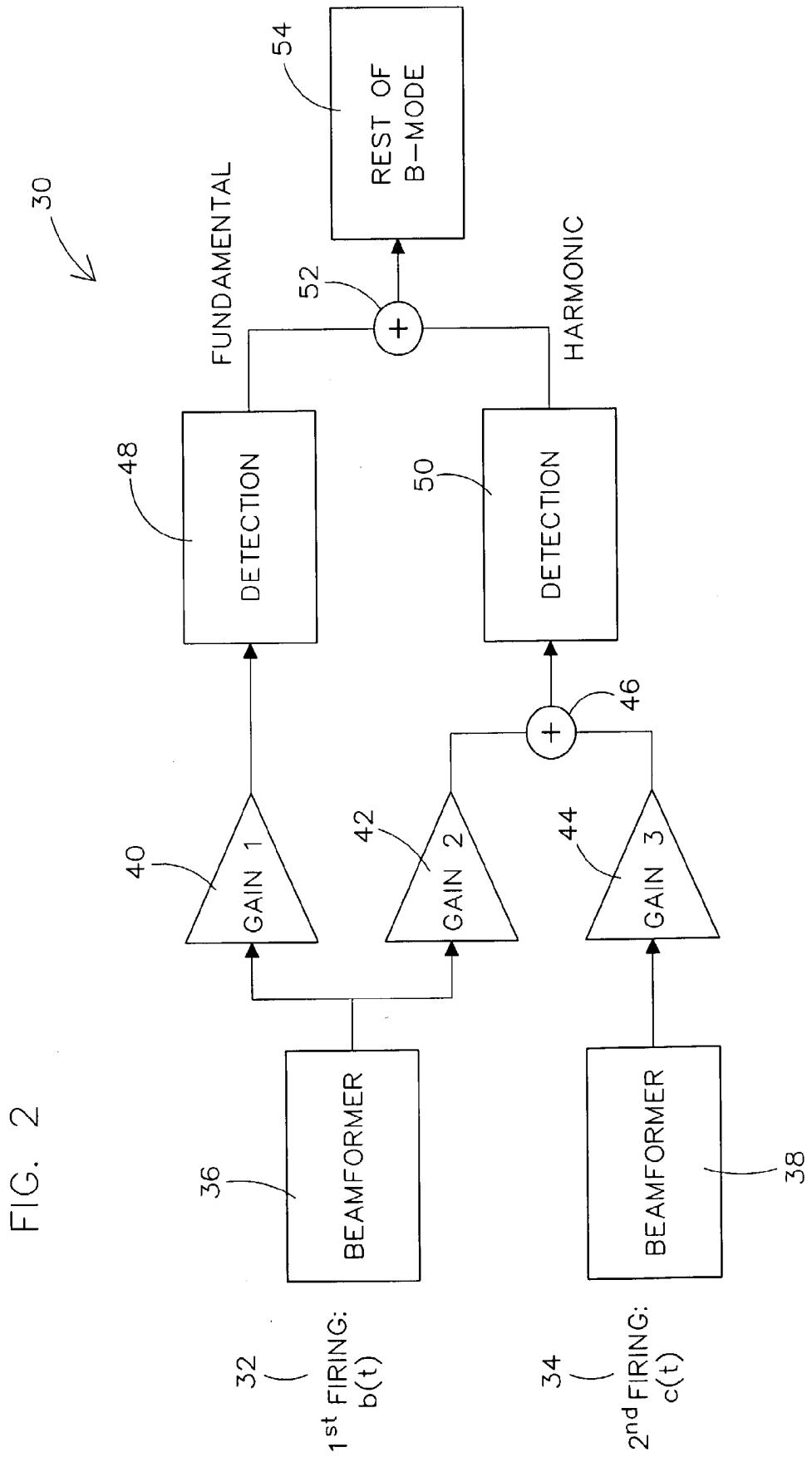

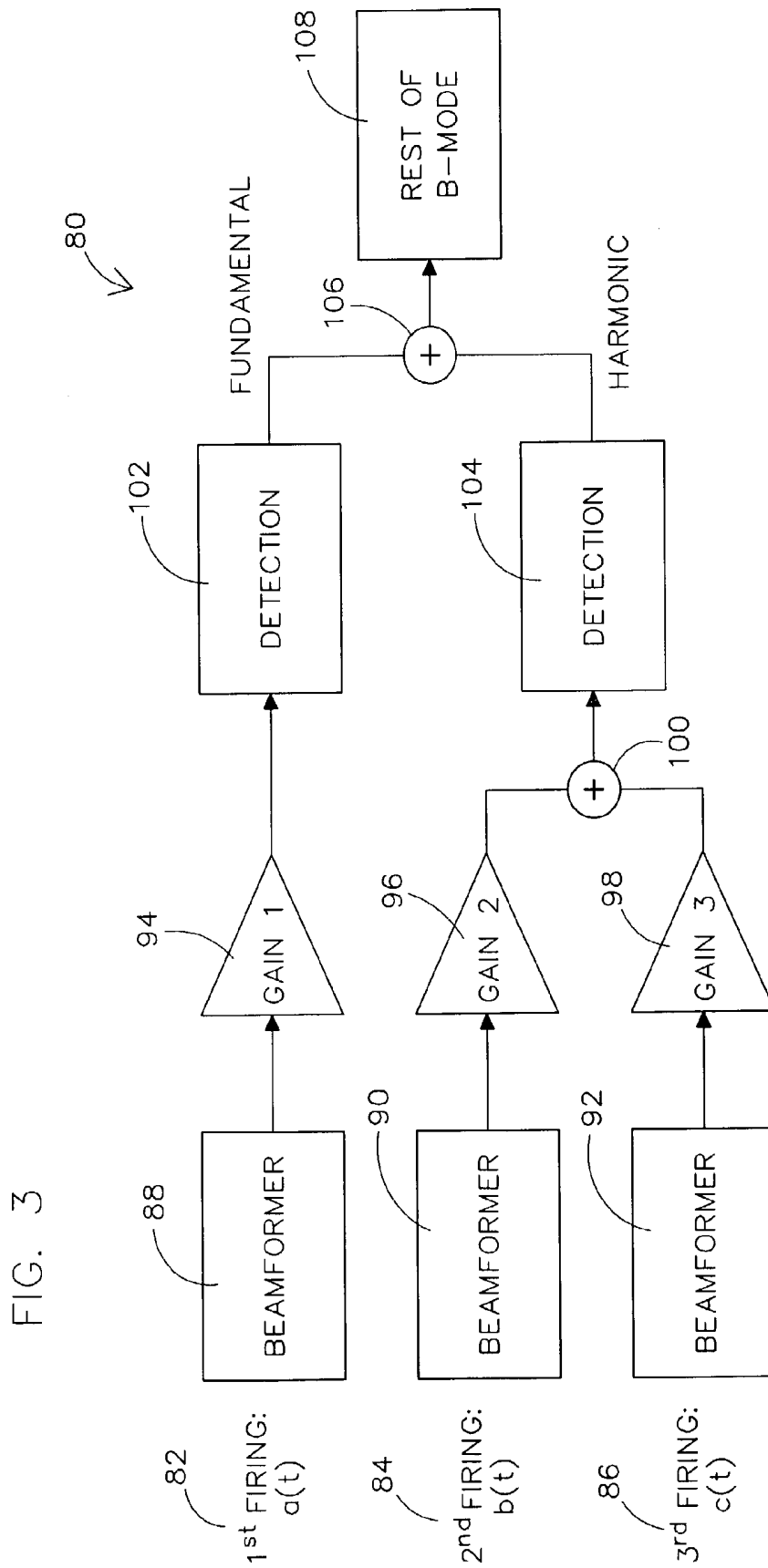

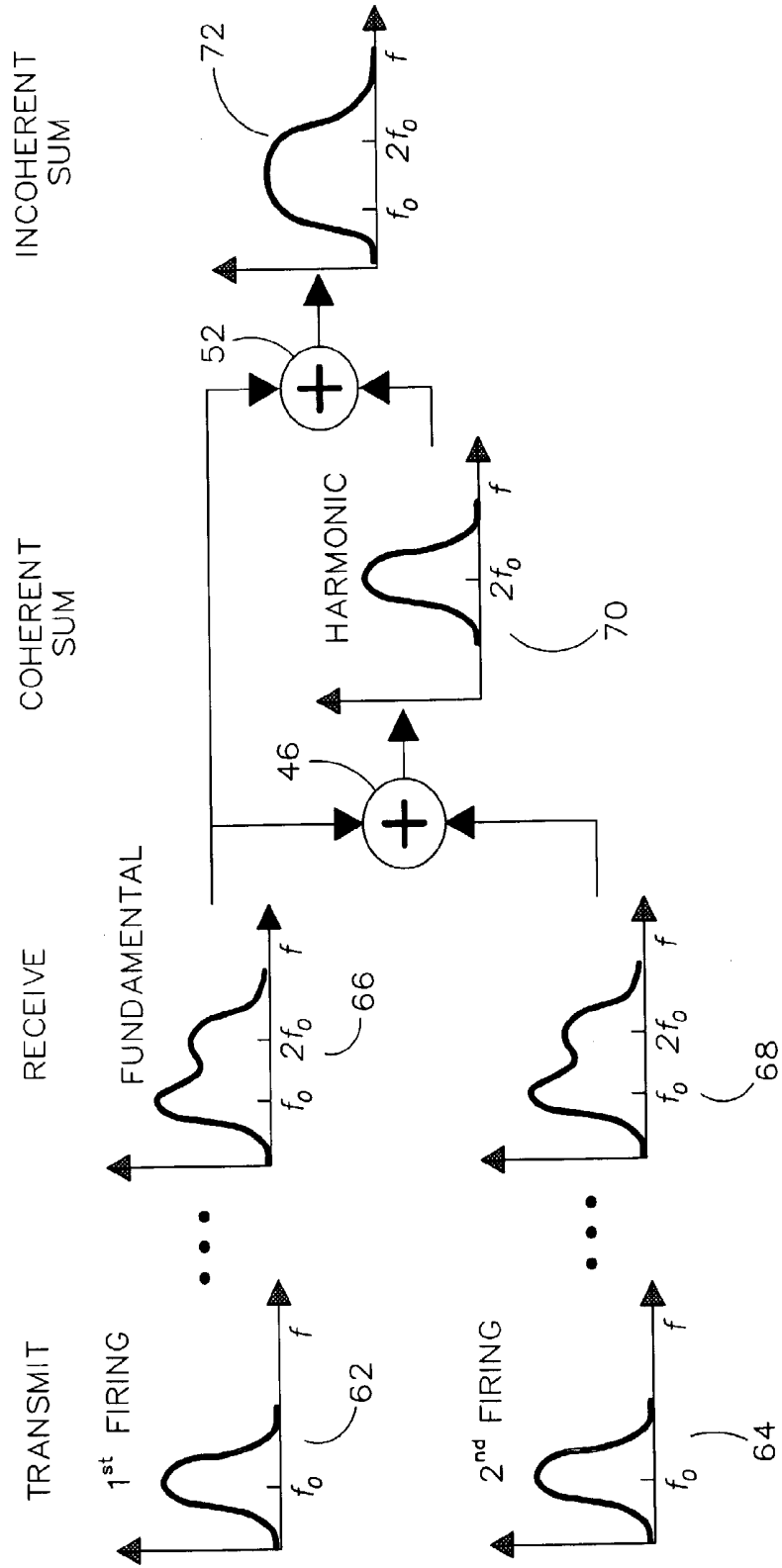

FIG. 4

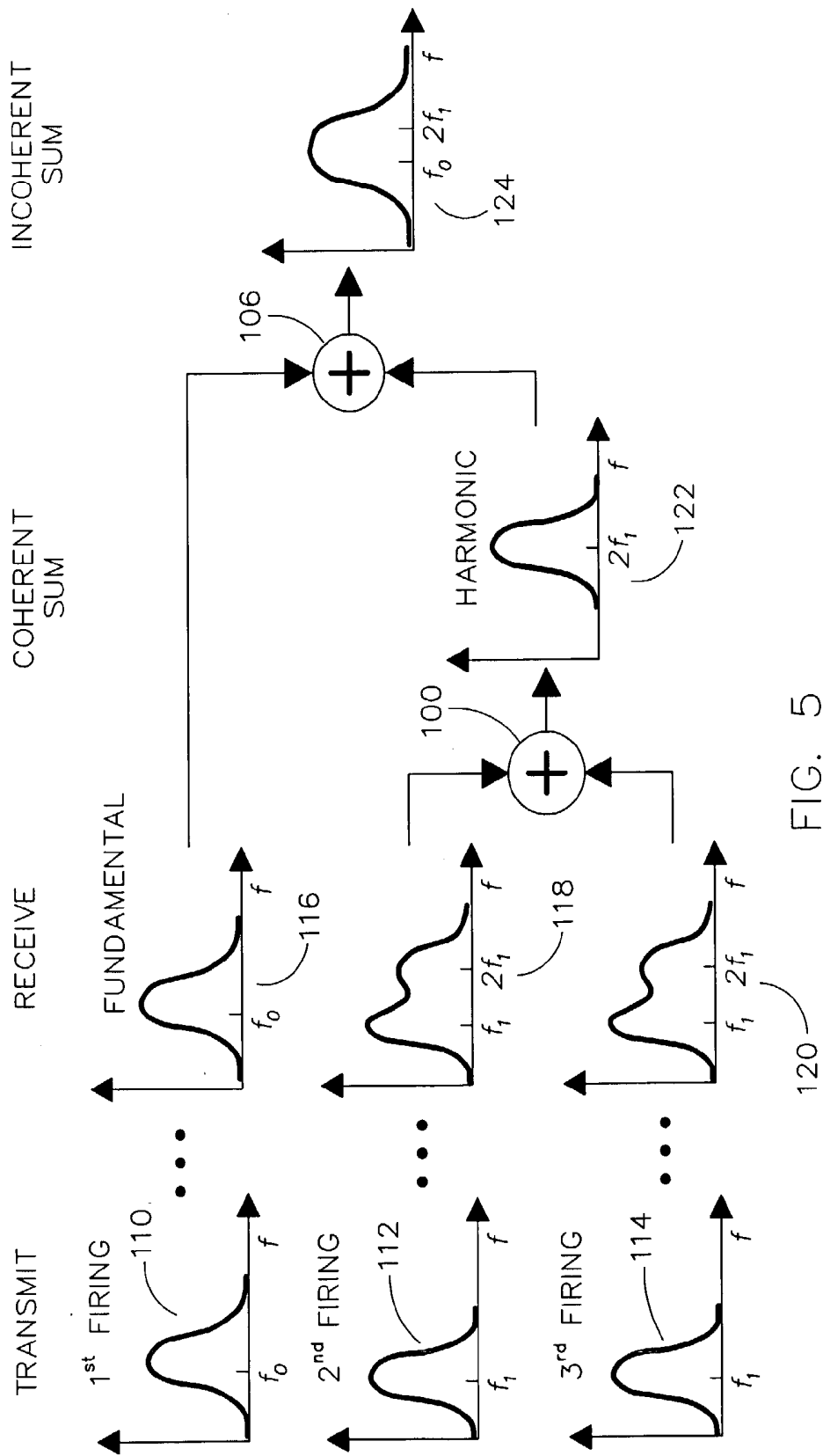

FIG. 5

**METHOD OF ULTRASONIC SPECKLE  
REDUCTION USING WIDE-BAND FREQUENCY  
COMPOUNDING WITH TISSUE-GENERATED  
HARMONICS**

**BACKGROUND OF THE INVENTION**

[0001] The present invention relates to ultrasound imaging, and more particularly, to a method and apparatus for enhancing ultrasound images by reducing speckle.

[0002] Ultrasound imaging is an attractive modality for numerous diagnostic procedures because of its non-invasive nature, relatively low cost, and lack of radiation exposure. Medical ultrasound images are typically produced by generating an ultrasonic sound wave traveling in a known direction, known as a scan line or a vector, and observing the echoes created when the sound wave is scattered or bounces off of the boundaries between regions of differing density in the body. For any given direction of the ultrasound beam, the image pixels are generated by plotting a dot whose brightness is proportional to the echoes' amplitude at a coordinate whose location is a function of the time after a short ultrasound pulse is sent in the direction of the scan line being measured.

[0003] When forming images with coherent radiation, the desired distribution of image energy is subject to undesirable random modulation. This random distribution of energy is known as "speckle" and is manifested in visual images as flecks of random intensity and size distributed across the image. Speckle arises from constructive and destructive interference due to random phase cancellations and additions of the coherent field which is scattered by the coherently illuminated object. The power spectrum of speckle depends upon the spectrum of the coherent signal carrier, the texture or spatial distribution of scatterers in the field, the size of the irradiated object volume, and the transfer function of the receiving and imaging system.

[0004] The speckle caused by random tissue scattering and ultrasonic images may overshadow delicate tissue structures and degrade the image contrast. Frequency compounding is a well-known way to reduce speckles and hence enhance contrast resolution. In frequency compounding, images with different frequency characteristics are summed incoherently. In the experience of these inventors, existing frequency compounding methods for speckle reduction suffer from resolution degradation due to summation of detected narrow-band signals. These narrow-band signals are typically obtained by narrow-band filtering on receipt. What is needed is a high-resolution compounding method and apparatus.

[0005] Broadly, it is the object of the present invention to provide an improved method and apparatus for ultrasound imaging.

[0006] It is another object of the present invention to provide an improved ultrasonic imaging method and apparatus that can distinguish tissues while reducing the amount of speckle that overshadows delicate structures and degrades the image contrast. It is yet another object of the present invention to provide such a method and apparatus while using wide-band frequency compounding with tissue-generated harmonics. These and other objects of the present invention will become apparent to those skilled in the art from the follow detailed description of the invention and the accompanying drawings.

**BRIEF SUMMARY OF THE INVENTION**

[0007] The present invention is a method and apparatus for smoothing the speckle pattern and increasing contrast resolution in ultrasound images. Compared to other frequency compounding techniques, wide-band harmonic frequency compounding reduces speckle noise without sacrificing the resolution. Compared to spatial compounding, wide-band harmonic frequency compounding is more robust against tissue motion because sequential vectors rather than frames are summed together for compounding. The method and apparatus of the present invention is implemented by transmitting two or more firings, combining two or more of the firings coherently to extract the tissue-generated harmonic components, detecting the outputs of the coherent sums and detecting one or more firings before coherent sum, and finally combining all detected outputs to form the compounded image.

[0008] The method and apparatus of the present invention sums wide-band fundamental and wide-band harmonic images after detection to form a compounded image. Unlike other frequency compounding methods, both transmit and receive signals are wide-band and no narrow-band filters are necessary. Multiple firings with two or more different transmit waveforms are transmitted to each focal zone.

**BRIEF DESCRIPTION OF THE DRAWINGS**

[0009] **FIG. 1** is a block diagram of an ultrasound imaging system according to the present invention.

[0010] **FIG. 2** is a schematic diagram illustrating the two-firing configuration in the method of the present invention.

[0011] **FIG. 3** is a schematic diagram illustrating the three-firing configuration in the method of the present invention.

[0012] **FIG. 4** is a spectrum diagram illustrating summation under the two-firing configuration shown in **FIG. 2**.

[0013] **FIG. 5** is a spectrum diagram illustrating summation under the three-firing configuration shown in **FIG. 3**.

**DETAILED DESCRIPTION OF THE  
INVENTION**

[0014] In general, an ultrasound beam is generated by using an array of transducers to form a transmit beam in a given direction with respect to the array. The ultrasound pulse is an amplitude modulated pulse at a predetermined frequency, having an amplitude specified by an envelope function. The echoes generated by this pulse are detected by the same, or a different, array of transducers that are used to form a receive beam corresponding to the transmit beam. The directional sensitivity of the microphone or ultrasonic probe, reduces echoes generated by multiple reflections of the sound pulse.

[0015] The ultrasound imaging is generally accomplished by a system that utilizes certain essential components. Referring now to **FIG. 1**, which is a block diagram of an ultrasound imaging system according to the method of the present invention, the ultrasound imaging system is generally identified **10**. The system **10** includes an ultrasonic probe **12**, a beamformer **14**, a coherent vector summation means **16**, a detection means **18**, an incoherent vector

summation means **20**, a post-processing means **22** and a scan converter and display means **24**. In general, the ultrasonic probe **12** is aligned with the object to be scanned and the operator uses the scan converter and display means **24** to visualize and observe the scan results as detected by the probe **12**.

[0016] This invention sums wide-band fundamental and wide-band harmonic images after detection to form a compounded image. Unlike other frequency compounding methods, both transmit and receive signals are wide-band and no narrow-band filters are necessary. Multiple firings with two or more different transmit waveforms are transmitted to each focal zone.

[0017] The method and apparatus of the present invention teaches compounding of wide-band images with different speckle patterns to suppress speckle without resolution loss. This is implemented by transmitting two or more firings, as shown by **FIGS. 2 and 3**, combining two or more of the firings coherently to extract the tissue-generated harmonic component, detecting output of the coherent sum and detecting one or more firings before coherent sum, and finally combining all detected outputs to form the compounded image. See also **FIGS. 4 and 5**.

[0018] Referring now to **FIGS. 2 through 5**, it will be seen that the transmit waveforms **62, 64, 110** generated by the beamformers **36, 38, 88**, respectively, are characterized by a peak power level near a fundamental frequency  $f_0$ . The transmit waveforms **112, 114** generated by the beamformers **90, 92**, respectively, are characterized by a peak power level near another fundamental frequency  $f_1$ . The ultrasound echo information generated by the beamformers includes information at the fundamental frequency and information generated non-linearly at the harmonic frequency. The echo information received by the beamformers is not filtered as in other prior methods to isolate the harmonic frequency information by substantially removing information at transmitted frequencies. In one embodiment, a wide-band harmonic image at  $2f_0$  is incoherently summed with a wide-band fundamental image at  $f_0$  and  $2f_0$  to form the final compounded image. There may be two firings or three firings for each focal zone.

[0019] Referring now to **FIGS. 2 and 4**, a two-firing configuration, generally identified **30**, is illustrated in schematic form. In the two-firing configuration **30**, the wide-band transmit waveforms **62, 64** of the two-firings **32, 34** at frequency  $f_0$  have the same amplitude but opposite phase. In other words, that situation would be represented by  $c(t)=-b(t)$ . The received signals **66** of one of the firings **62** is detected **48** to form a wide-band fundamental vector, also at  $f_0$ . The received signals **66, 68** of the two-firings **32, 34** are summed **46** with equal weighting, i.e.  $\text{Gain } 2=\text{Gain } 342, 44$ , and are detected **50** to form a wide-band harmonic vector **70** at  $2f_0$ . The two vectors **66, 70** are then summed **52** to form the compounded image **72**. The weighting  $\text{Gain } 140$  is set to a certain value so that the speckle of the fundamental image and the harmonic image has approximately the same brightness.

[0020] In the three-firing setting, generally identified **80**, as shown in **FIGS. 3 and 5**, the first firing **82** with transmit waveform  $a(t)$  **110** is used to form a wide-band fundamental vector **116**. The other two firings **84, 86** with transmit waveforms  $b(t)$  **112** and  $c(t)$  **114** with the same amplitude

and opposite phase are combined **100** to form a wide-band harmonic vector **122**. The transmit waveform  $a(t)$  **110** is different from  $b(t)$  **112** and  $c(t)$  **114**. The two vectors **116, 122** are then summed **106** to form the compounded image **124**. The gain setting **94, 96, 98** in this configuration **80** is the same as that in the two-firing case **30**. The two-firing configuration **30** gives higher frame rate while the three-firing configuration **80** ensures optimized quality for both fundamental and harmonic images.

[0021] In another embodiment, the wide-band harmonic image is obtained by firing two wide-band waveforms with the same phase but different amplitudes. The two-firings are then coherently summed with  $\text{Gain } 3=-\text{Gain } 2/\beta$  to cancel the fundamental and extract the harmonic component. The same two-firing or three-firing settings stated above may be used in this embodiment.

[0022] In yet another embodiment, detection and log compression are performed prior to the summation of fundamental and harmonic vectors. This is equivalent to multiplying the detected vectors together for compounding.

[0023] It should also be understood that the foregoing embodiments could be extended to other multiple firing and wide-band compounding combinations that can be generally expressed as follows. First, two or more ultrasound firings would be made. These firings would be divided into several groups. In this way, each group can share firings with other groups. For groups with more than one firing, the firings would be coherently combined to form tissue-generated harmonic components. The harmonic components can include sub-harmonic, ultra-harmonics, 2<sup>nd</sup> order harmonic, and higher order harmonic. The number of groups with more than one firing could be one or more. The number of groups with one firing could also be one or more. For each group, the output of the coherent sum is detected in the case of two or more firings and the firing is directly detected in the case of one firing. All detected outputs are combined to form the compounded image as described above.

[0024] Accordingly, it will be seen that the present invention is a method and apparatus for smoothing the speckle pattern and increasing contrast resolution in ultrasound images. Compared to other frequency compounding techniques, wide-band harmonic frequency compounding reduces speckle noise without sacrificing resolution. Compared to spatial compounding, wide-band harmonic frequency compounding is more robust against tissue motion because sequential vectors rather than frames are summed together for compounding. The method and apparatus of the present invention is implemented by transmitting two or more firings, combining two or more of the firings coherently to extract the tissue-generated harmonic component, detecting the output of the coherent sum and detecting one or more firings before coherent sum, and finally combining all detected outputs to form the compounded image.

[0025] The method and apparatus of the present invention sums wide-band fundamental and wide-band harmonic images after detection to form a compounded image. Unlike other frequency compounding methods, both transmit and receive signals are wide-band and no narrow-band filters are necessary. Multiple firings with two or more different transmit waveforms are transmitted to each focal zone. It is intended that the foregoing be regarded as illustrative of the

method of the present invention, rather than limiting. It is the following claims that are intended to define the scope of this invention.

## PARTS LIST

[0026]	10	ultrasound imaging system
[0027]	12	ultrasonic probe
[0028]	14	beamformer
[0029]	16	coherent vector summation means
[0030]	18	detection means
[0031]	20	incoherent vector summation means
[0032]	22	post-processing means
[0033]	24	scan converter and display means
[0034]	30	two-firing configuration
[0035]	32	first firing
[0036]	34	second firing
[0037]	36	beamformer
[0038]	38	beamformer
[0039]	40	gain 1
[0040]	42	gain 2
[0041]	44	gain 3
[0042]	46	summation
[0043]	48	detector
[0044]	50	detection
[0045]	52	summation
[0046]	54	rest of b-mode
[0047]	62	transmit waveform generated by 36
[0048]	64	transmit waveform generated by 38
[0049]	66	received signal
[0050]	68	received signal
[0051]	70	vector
[0052]	72	compounded image
[0053]	80	three-firing configuration
[0054]	82	first firing
[0055]	84	second firing
[0056]	86	third firing
[0057]	88	beamformer
[0058]	90	beamformer
[0059]	92	beamformer
[0060]	94	gain 1
[0061]	96	gain 2
[0062]	98	gain 3
[0063]	100	summation
[0064]	102	detection

[0065]	104	detection
[0066]	106	summation
[0067]	108	rest of b-mode
[0068]	110	transmit waveform generated by 88
[0069]	112	transmit waveform generated by 90
[0070]	114	transmit waveform generated by 92
[0071]	116	wide-band fundamental vector
[0072]	118	receive vector
[0073]	120	receive vector
[0074]	122	wide-band harmonic vector
[0075]	124	compounded image

What is claimed is:

1. In a method or a system for generating an ultrasound image in which ultrasound pulses comprising amplitude modulated signals are transmitted into a specimen and echoes generated by the ultrasound pulses are received from the specimen, a method for reducing speckle in the resulting ultrasound image comprising the steps of

- (a) transmitting two or more ultrasound firings,
- (b) combining two or more of the firings coherently to extract the tissue-generated harmonic components thereof,
- (c) detecting the outputs of the coherent sums and detecting one or more firings before coherent sum, and
- (d) combining all detected outputs to form the compounded image.

2. The method of claim 1 wherein said firing transmission step includes transmitting a first wide-band waveform and a second wide-band waveform at a fundamental frequency.

3. The method of claim 2 wherein said firing detection step includes detecting the received signals of the first waveform to form a wide-band fundamental vector output and combining and detecting the received signals of the first and second waveforms to form a wide-band harmonic vector output.

4. The method of claim 1 wherein the received signals of the two or more firings are summed with equal gain and the received signals of one of the firings is given a weighted gain so that speckle of the fundamental image and the harmonic image has approximately the same brightness.

5. The method of claim 1 wherein a wide-band harmonic image is obtained by firing two or more waveforms with the same shape but different amplitude, coherently summing the firings with gain set so as to cancel the fundamental component and extract the harmonic component.

6. The method of claim 1 wherein the harmonic components can be sub-harmonic, ultra-harmonic, second order harmonic, or higher order harmonic.

7. An ultrasonic method for generating data for imaging and for reducing speckle comprising the steps of

- (a) transmitting two or more ultrasound firings,
- (b) combining two or more of the firings coherently to extract the tissue-generated harmonic components thereof,

(c) detecting the outputs of the coherent sums and detecting one or more firings before coherent sum, and

(d) combining all detected outputs to form the compounded image.

8. The method of claim 7 wherein said firing transmission step includes transmitting a first wide-band waveform and a second wide-band waveform at a fundamental frequency.

9. The method of claim 8 wherein said firing detection step includes detecting the received signals of the first waveform to form a wide-band fundamental vector output and combining and detecting the received signals of the first and second waveforms to form a wide-band harmonic vector output.

10. The method of claim 7 wherein the received signals of the two or more firings are summed with equal gain and the received signals of one of the firings is given a weighted gain so that speckle of the fundamental image and the harmonic image has approximately the same brightness.

11. The method of claim 7 wherein a wide-band harmonic image is obtained by firing two or more waveforms with the same shape but different amplitude, coherently summing the firings with gain set so as to cancel the fundamental component and extract the harmonic component.

12. The method of claim 7 wherein the harmonic components can be sub-harmonic, ultra-harmonic, second order harmonic, or higher order harmonic.

13. An ultrasonic imaging method comprising the following steps

(a) transmitting two or more ultrasound firings,

(b) combining two or more of the firings coherently to extract the tissue-generated harmonic components thereof,

(c) detecting the outputs of the coherent sums and detecting one or more firings before coherent sum, and

(d) combining all detected outputs to form the compounded image,

whereby speckle in the image is reduced.

14. The method of claim 13 wherein said firing transmission step includes transmitting a first wide-band waveform and a second wide-band waveform at a fundamental frequency.

15. The method of claim 13 wherein said firing detection step includes detecting the received signals of the first waveform to form a wide-band fundamental vector output and combining and detecting the received signals of the first and second waveforms to form a wide-band harmonic vector output.

16. The method of claim 13 wherein the received signals of the two or more firings are summed with equal gain and the received signals of one of the firings is given a weighted gain so that speckle of the fundamental image and the harmonic image has approximately the same brightness.

17. The method of claim 13 wherein a wide-band harmonic image is obtained by firing two or more waveforms with the same shape but different amplitude, coherently summing the firings with gain set so as to cancel the fundamental component and extract the harmonic component.

18. The method of claim 13 wherein the harmonic components can be sub-harmonic, ultra-harmonic, second order harmonic, or higher order harmonic.

19. For use in a system for generating an ultrasound image in which ultrasound pulses comprising amplitude modulated signals are transmitted into a specimen and echoes generated by the ultrasound pulses are received from the specimen, an apparatus for reducing speckle in the resulting ultrasound image which comprises

(a) means for transmitting two or more ultrasound firings,

(b) means for combining two or more of the firings coherently to extract the tissue-generated harmonic components thereof,

(c) means for detecting the outputs of the coherent sums and detecting one or more firings before coherent sum, and

(d) means for combining all detected outputs to form the compounded image.

20. The apparatus of claim 19 wherein said firing transmission means includes means for transmitting a first wide-band waveform and a second wide-band waveform at a fundamental frequency.

21. The apparatus of claim 19 wherein said firing means includes one or more beamformers for generating ultrasound echo information and wherein the ultrasound information generated by the one or more beamformers includes information generated at the fundamental frequency and information generated non-linearly at the harmonic frequency.

22. The apparatus of claim 19 wherein the harmonic components can be sub-harmonic, ultra-harmonic, second order harmonic, or higher order harmonic.

23. An ultrasound imaging apparatus which comprises

(a) an ultrasonic probe,

(b) one or more beamformers,

(c) a coherent vector summation means,

(d) a detection means,

(e) an incoherent vector summation means,

(f) a post-processing means, and

(g) a scan converter and image display means.

whereby speckle in the resulting displayed image is reduced.

24. The apparatus of claim 23 wherein said beamformers include means for transmitting a first wide-band waveform and a second wide-band waveform at a fundamental frequency via the probe.

25. The apparatus of claim 23 wherein ultrasound echo information generated by the beamformers includes information at the fundamental frequency and information generated non-linearly at the harmonic frequency.

26. The apparatus of claim 23 wherein said detection means includes means for detecting the received signals of the first waveform to form a wide-band fundamental vector output and combining and detecting the received signals of the first and second waveforms to form a wide-band harmonic vector output.

27. The apparatus of claim 23 including detection means wherein the received signals of two or more firings are summed with equal gain and the received signals of one of the firings is given a weighted gain so that speckle of the fundamental image and the harmonic image has approximately the same brightness.

**28.** The apparatus of claim 23 wherein a wide-band harmonic image is obtained by firing two or more waveforms with the same shape but different amplitude, coherently summing the firings with gain set so as to cancel the fundamental component and extracting the harmonic component therefrom.

**29.** The apparatus of claim 23 wherein the harmonic components can be sub-harmonic, ultra-harmonic, second order harmonic, or higher order harmonic.

\* \* \* \* \*

专利名称(译)	使用组织产生的谐波的宽带频率复合的超声波散斑减少方法		
公开(公告)号	<a href="#">US20040127795A1</a>	公开(公告)日	2004-07-01
申请号	US10/335277	申请日	2002-12-31
申请(专利权)人(译)	通用电气医疗系统全球性技术公司，有限责任公司		
当前申请(专利权)人(译)	通用电气医疗系统全球性技术公司，有限责任公司		
[标]发明人	LIN FENG PANDA SATCHI CHIAO RICHARD YUNG		
发明人	LIN, FENG PANDA, SATCHI CHIAO, RICHARD YUNG		
IPC分类号	G01N29/44 A61B8/00 G01S7/52 G01S15/89 G06T5/00 G06T5/10		
CPC分类号	G01S7/52046 G01S15/895 G06T2207/30004 G06T5/002 G06T2207/10132 G06T5/10		
其他公开文献	US6827685		
外部链接	<a href="#">Espacenet</a> <a href="#">USPTO</a>		

摘要(译)

提供了一种用于平滑散斑图案并增加超声图像中的对比度分辨率的方法和装置。与其他频率复合技术相比，宽带谐波频率复合可在不牺牲分辨率的情况下降低散斑噪声。与空间复合相比，宽带谐波频率复合对于组织运动更加鲁棒，因为顺序矢量而不是帧被加在一起用于复合。该方法和装置通过发送两个或多个点火来实现，将两个或多个点火相干地组合以提取组织产生的谐波分量，检测相干和的输出并检测相干和之前的一个或多个点火，最后组合所有检测到的输出形成复合图像。该方法和装置在检测之后对宽带基波和宽带谐波图像求和以形成复合图像。与其他频率复合方法不同，发射和接收信号都是宽带的，不需要窄带滤波器。具有两个或更多个不同发射波形的多次发射被发送到每个聚焦区域。

