



(19) **United States**

(12) **Patent Application Publication**
Jibiki

(10) **Pub. No.: US 2002/0103437 A1**

(43) **Pub. Date: Aug. 1, 2002**

(54) **BLOOD FLOW IMAGING METHOD, BLOOD FLOW IMAGING APPARATUS AND ULTRASONIC DIAGNOSTIC APPARATUS**

(57) **ABSTRACT**

(76) Inventor: **Takao Jibiki, Tokyo (JP)**

Correspondence Address:
MOONRAY KOJIMA
BOX 627
WILLIAMSTOWN, MA 01267 (US)

(21) Appl. No.: **10/034,850**

(22) Filed: **Dec. 27, 2001**

(30) **Foreign Application Priority Data**

Feb. 1, 2001 (JP) 2001-25716

Publication Classification

(51) **Int. Cl.⁷ A61B 8/02**
(52) **U.S. Cl. 600/454**

In order to properly discern a plurality of streams of blood flow having different contrast agent arrival times or blood concentration properties, an ultrasonic diagnostic apparatus **200** comprises: an ultrasonic probe **1**; a transceiver section **2**; a quadrature detector section **3**; a power calculating section **4** for calculating the power **P** of blood flow; a power peak holding section **21** for comparing the latest power **P** and a predecessor peak value **P_o**, and outputting the larger one as a peak value **P'** and an elapsed time **t'** corresponding to the peak value **P'**; a predecessor power/elapsed time keeping section **22** for keeping the predecessor peak value **P_o** and the corresponding elapsed time '**t_o**' and outputting these values to the power peak holding section **21**; a timer **11** for measuring an elapsed time **t** from a reference time; a blood flow image producing section **25** for producing a power peak hold blood flow image **G2** in which the hue is changed before and after the elapsed time **t'** reaches a hue change time **t_c** and the brightness varies depending upon the peak value **P'**; an operating section **12** for resetting the timer **11** and specifying the hue change time **t_c**; and a display **6**. For example, blood flow passing through the hepatic artery and that passing through the portal vein can be displayed in different colors.

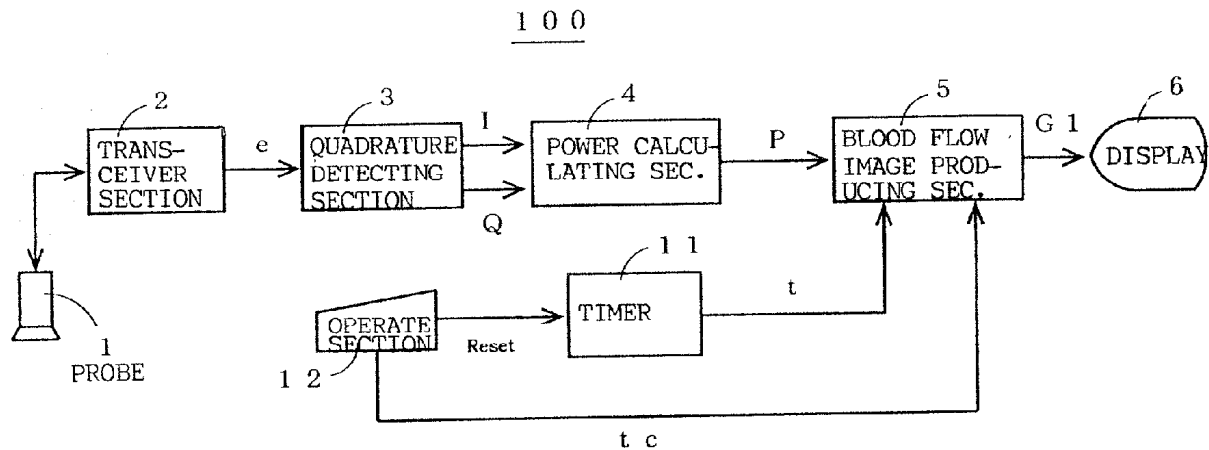

FIG. 1
(PRIOR ART)

500

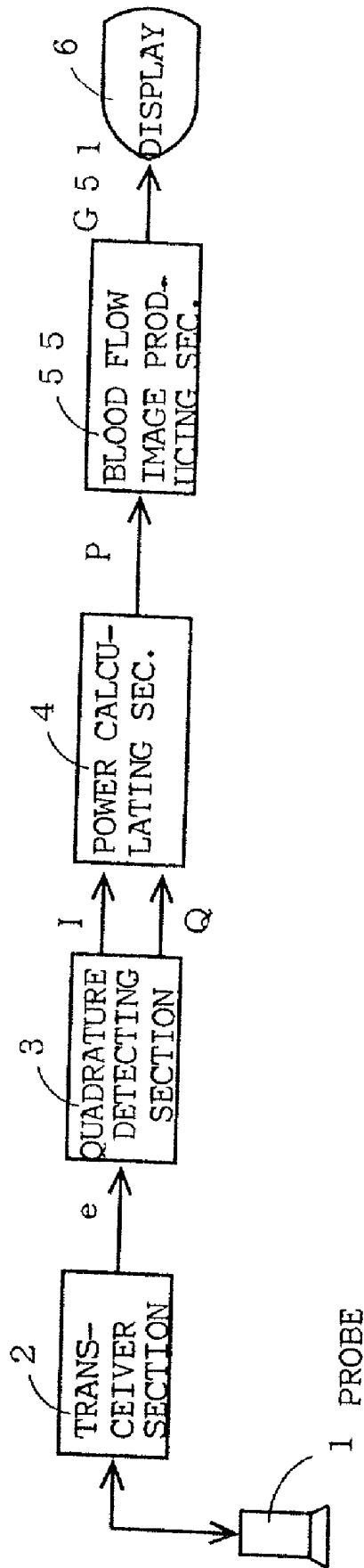

FIG. 2

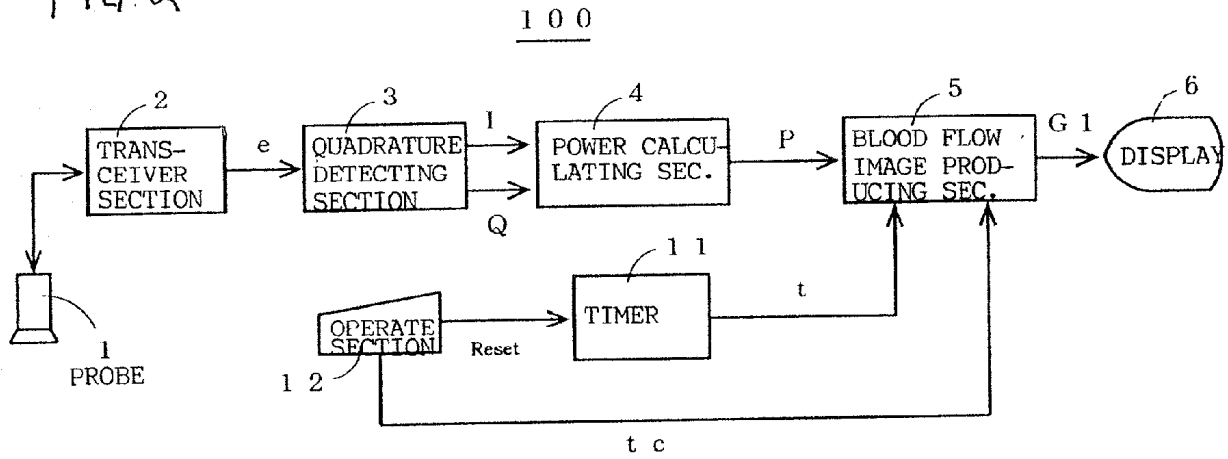

FIG. 3

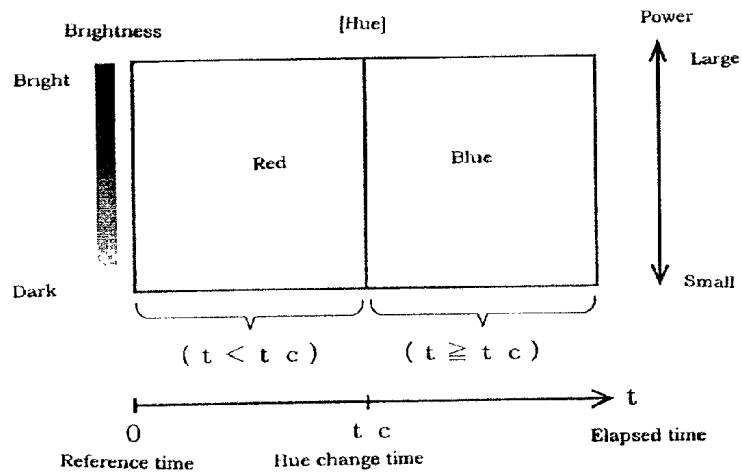
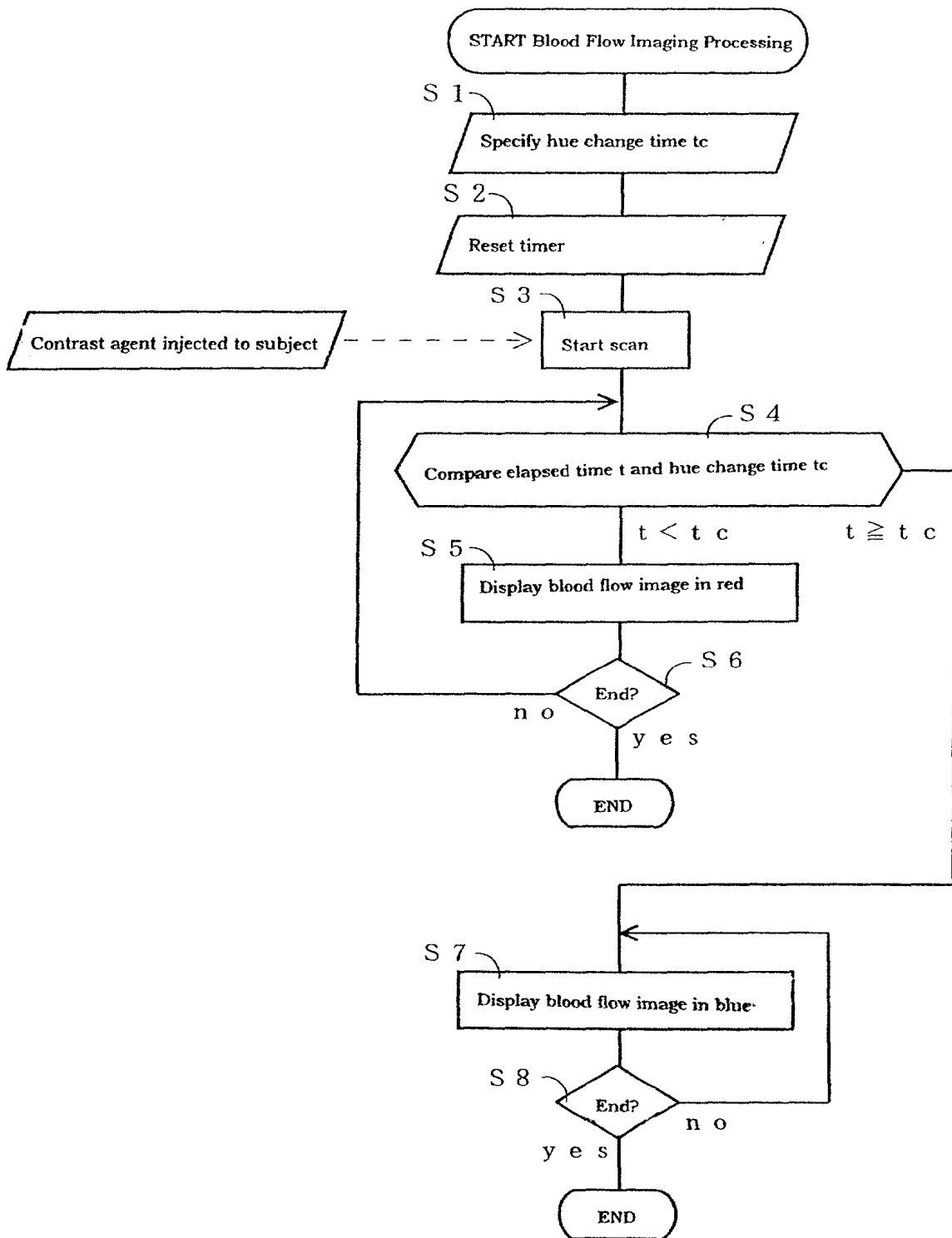

FIG. 4



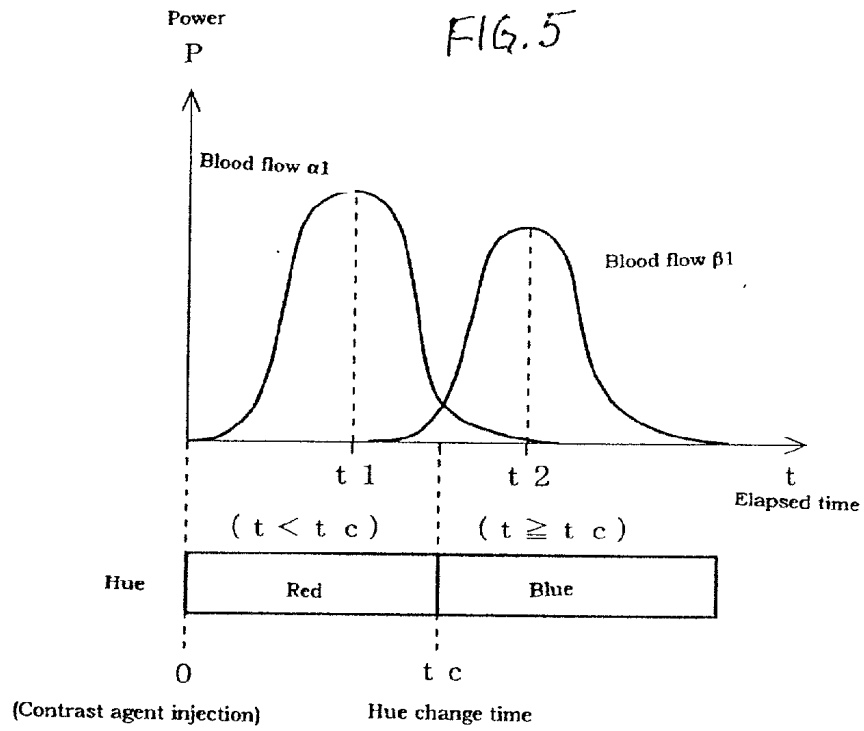

FIG. 6A

Blood flow image

G 1 (t_1)



Blood flow (Bright red)

FIG. 6B

Blood flow image

G 1 (t_c)

Blood flow (Dark blue)

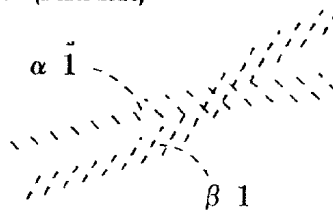

Blood flow (Dark blue)

FIG. 6C

Blood flow image

G 1 (t_2)

Blood flow (Bright blue)



FIG. 7

200.

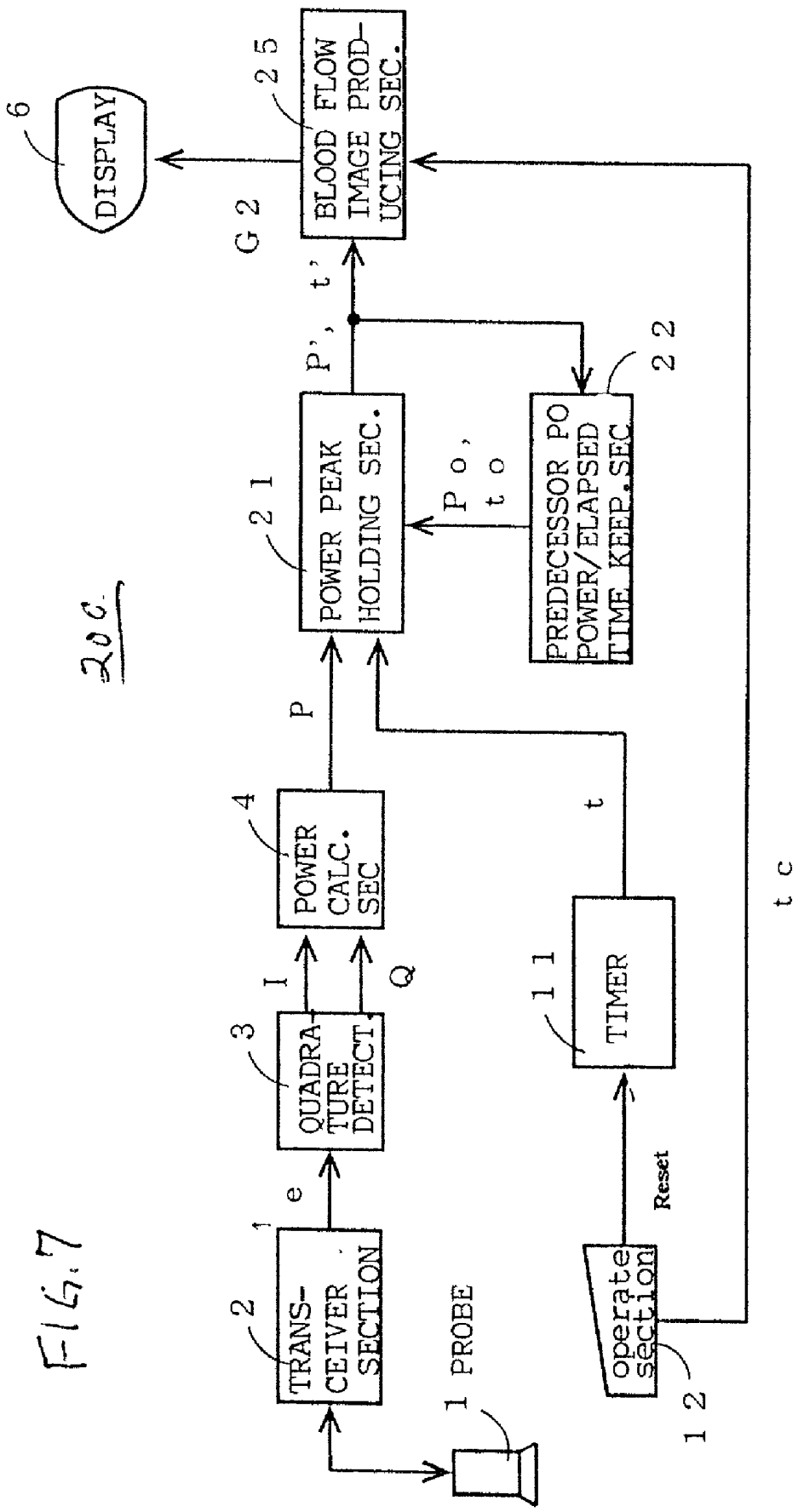

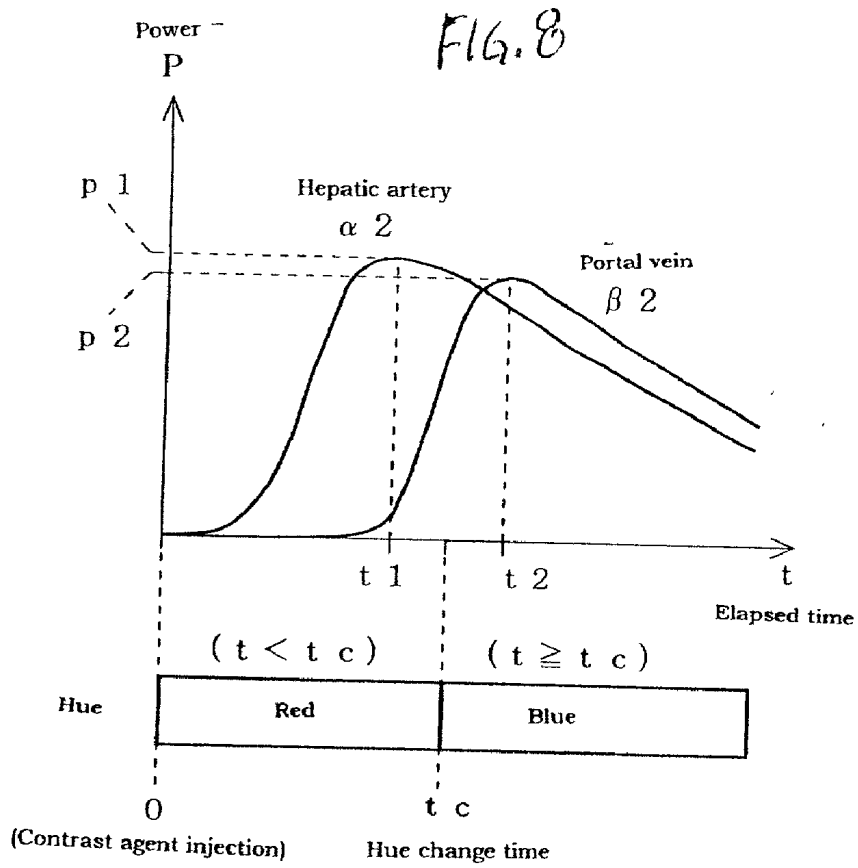
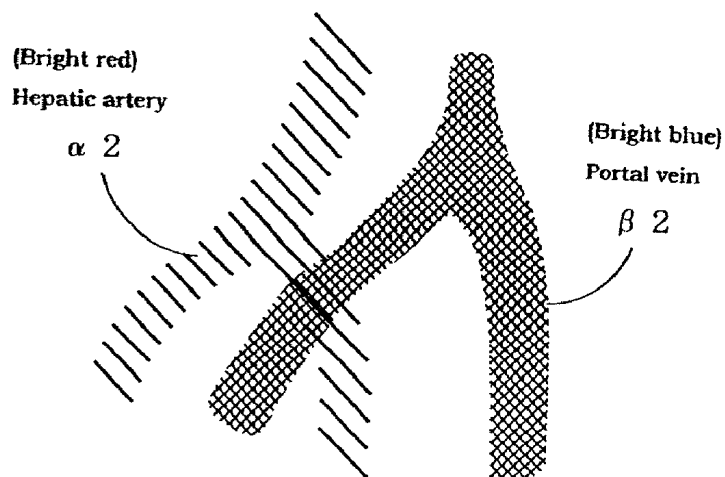
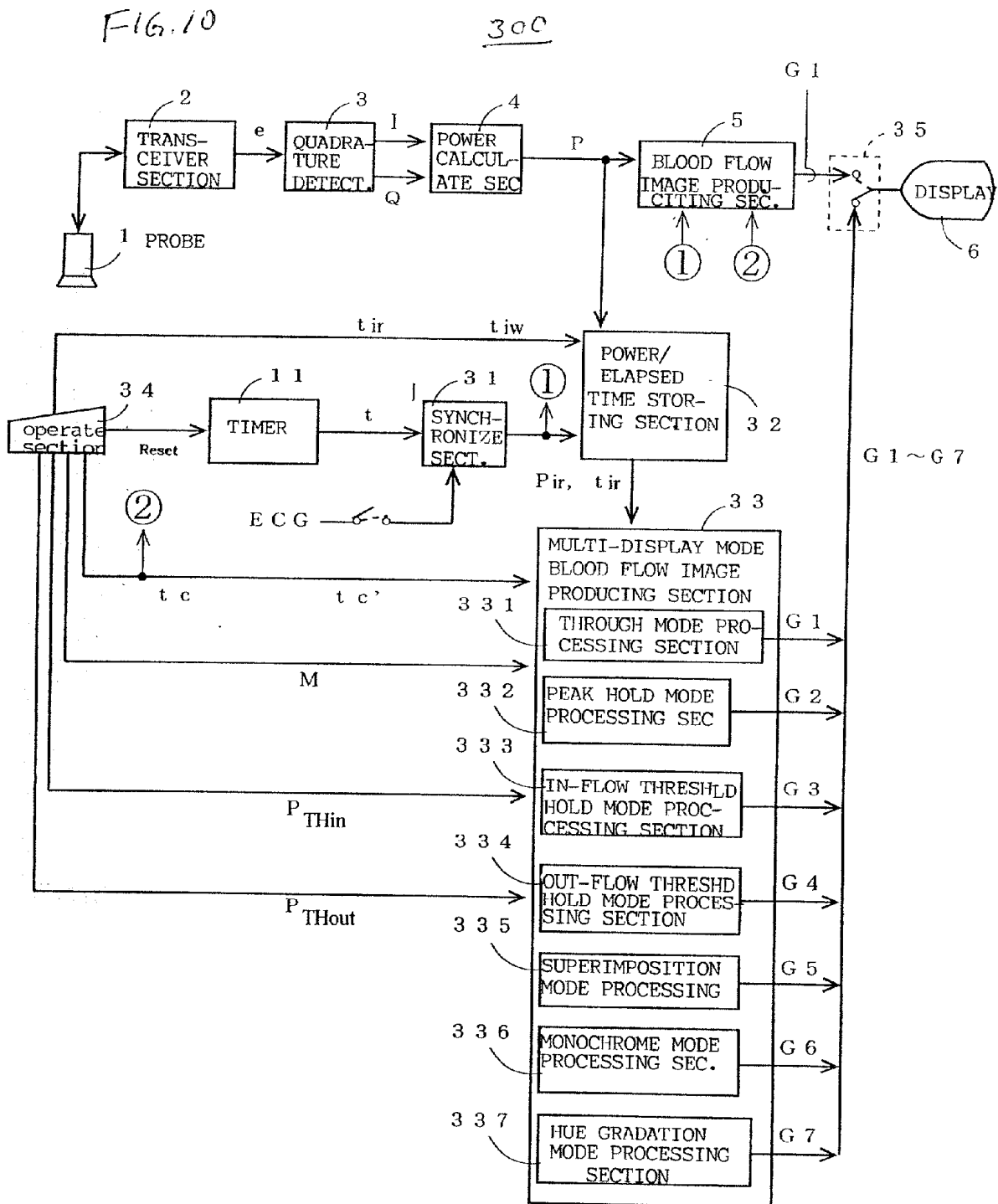

FIG. 9

Power Peak Hold
Blood Flow Image
G 2





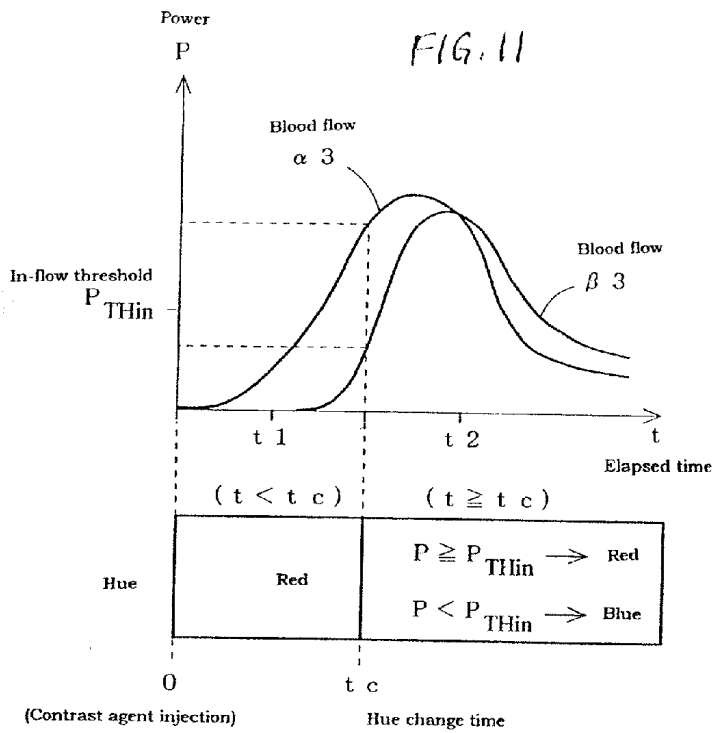

FIG. 12A

In-flow threshold hold mode blood flow image

G 3 (t_1)

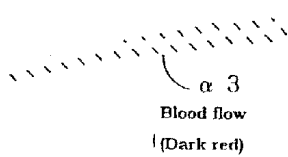

FIG. 12B

In-flow threshold hold mode blood flow image

G 3 (t_c)

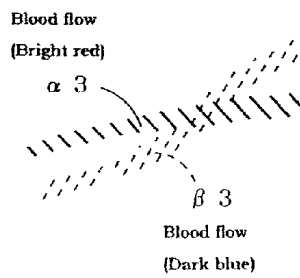
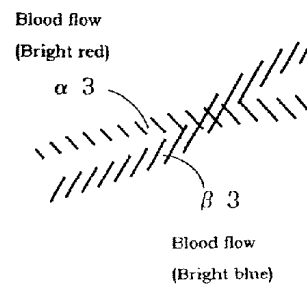

FIG. 12C

In-flow threshold hold mode blood flow image

G 3 (t_2)



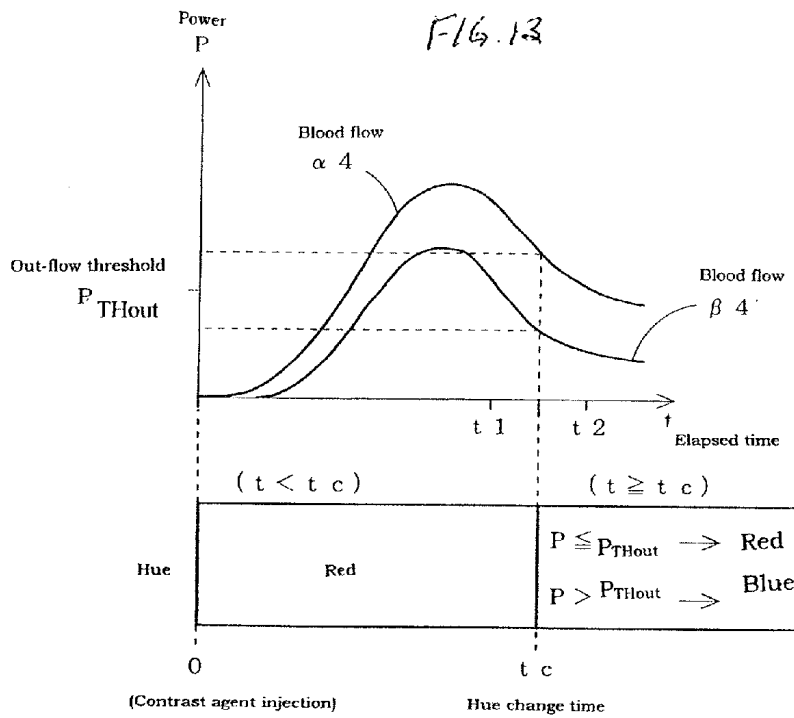

FIG. 14A

FIG. 14B

FIG. 14C

Out-flow threshold hold mode blood flow image Out-flow threshold hold mode blood flow image Out-flow threshold hold mode blood flow image

G 4 (t_1)

G 4 (t_c)

G 4 (t_2)

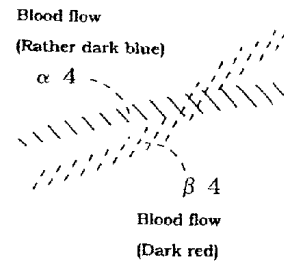
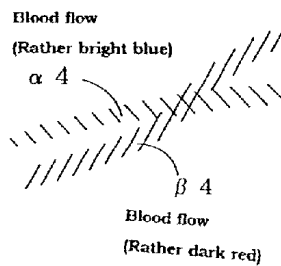
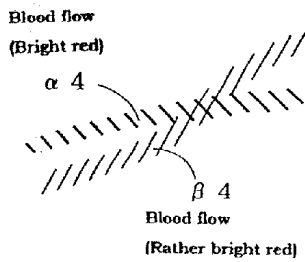

FIG. 15A

Blood flow image

G 1 (t 1)

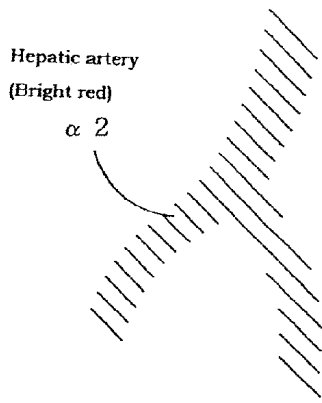
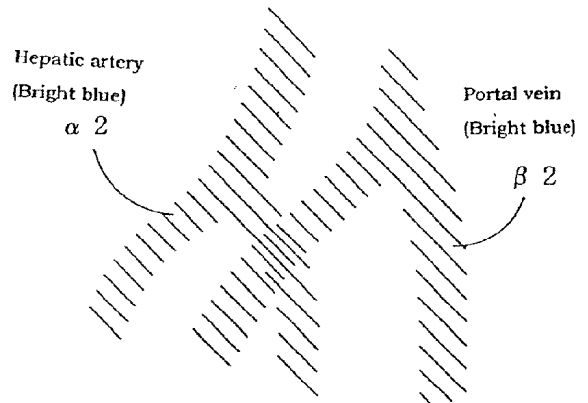

FIG. 15B

Blood flow image

G 1 (t 2)



Superimpose

FIG. 15C

Superimposition mode blood flow image

G 5

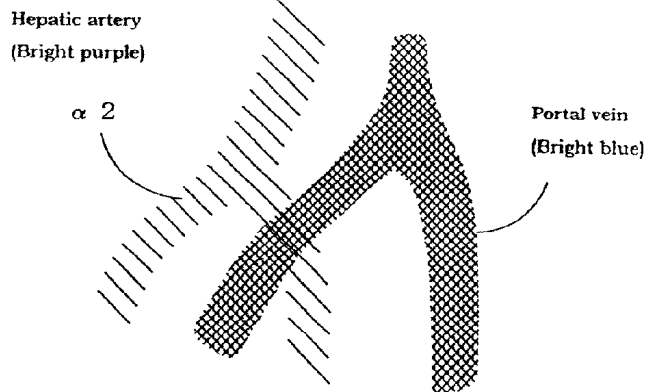

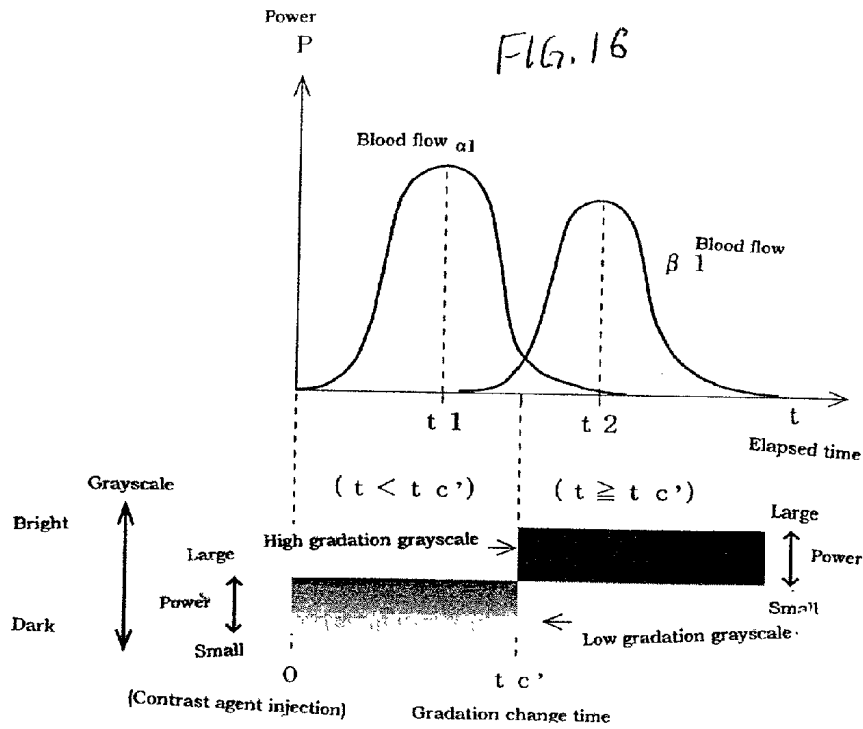

FIG. 17A

Monochrome mode blood flow image

G 6 ($t = t 1$)

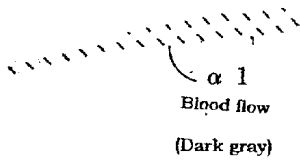

FIG. 17B

Monochrome mode blood flow image

G 6 ($t = t c'$)

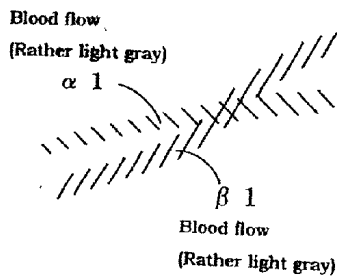

FIG. 17C

Monochrome mode blood flow image

G 6 ($t = t 2$)

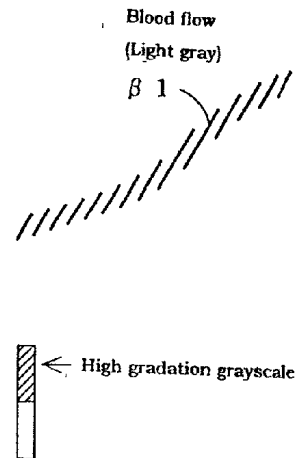
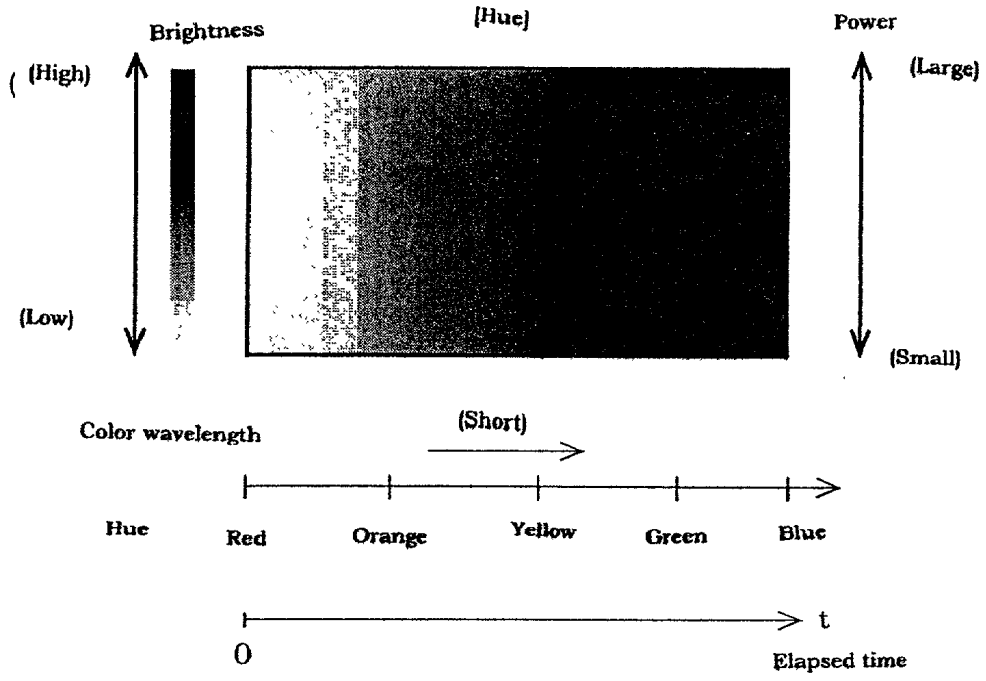

FIG. 18



BLOOD FLOW IMAGING METHOD, BLOOD FLOW IMAGING APPARATUS AND ULTRASONIC DIAGNOSTIC APPARATUS

BACKGROUND OF THE INVENTION

[0001] The present invention relates to a blood flow imaging method, blood flow imaging apparatus and ultrasonic diagnostic apparatus, and more particularly to a blood flow imaging method, blood flow imaging apparatus and ultrasonic diagnostic apparatus by which a plurality of streams of blood flow having different contrast agent arrival times or blood concentration properties can be properly discerned.

RELATED ART

[0002] FIG. 1 is a block diagram showing an example of a conventional ultrasonic diagnostic apparatus having a power Doppler mode.

[0003] The ultrasonic diagnostic apparatus 500 comprises: an ultrasonic probe 1; a transceiver section 2 for transmitting ultrasound from the ultrasonic probe 1, acquiring an ultrasonic echo and outputting a received signal e based on the ultrasonic echo; a quadrature detector section 3 for outputting in-phase (I) and quadrature (Q) components of the received signal e ; a power calculating section 4 for calculating the power P of blood flow; a blood flow image producing section 55 for producing a blood flow image G51 in which the brightness varies depending upon the power P ; and a display 6. The blood flow image G51 is displayed in, for example, orange of higher brightness for the larger power P .

[0004] When a contrast agent (microballoons) is intravenously injected into a subject, blood flow infused with the contrast agent is represented. In imaging the liver, for example, as the contrast agent carried by the blood flow reaches the hepatic artery and the portal vein, the blood flow streams passing through these blood vessels are represented.

[0005] In the conventional ultrasonic diagnosis apparatus 500, there is a problem that, for example, the blood flow passing through the hepatic artery and that passing through the portal vein are displayed overlapping each other on a screen, and they are difficult to properly distinguish.

SUMMARY OF THE INVENTION

[0006] It is therefore an object of the present invention to provide a blood flow imaging method, blood flow imaging apparatus and ultrasonic diagnostic apparatus by which a plurality of streams of blood flow having different contrast agent arrival times or blood concentration properties can be properly discerned.

[0007] In accordance with a first aspect, the present invention provides a blood flow imaging method for scanning and detecting blood flow infused with a contrast agent injected into a subject, and displaying the blood flow, comprising: changing at least one of the hue and gradation range of a display region representing the blood flow in one or more steps in the course of time.

[0008] In the blood flow imaging method of the first aspect, since the hue or display gradation of a blood flow image is changed relative to time, a plurality of streams of blood flow having different arrival times of a contrast agent can be properly discerned.

[0009] In accordance with a second aspect, the present invention provides a blood flow imaging method for scanning and detecting blood flow infused with a contrast agent injected into a subject, and displaying the blood flow, comprising: displaying a plurality of streams of blood flow having different times at which the blood flow detection intensity reaches a peak value, in different hues or gradation ranges.

[0010] In the blood flow imaging method of the second aspect, even if a time period in which a plurality of streams of blood flow are simultaneously infused with the contrast agent is long, the hues or display gradations of the blood flow streams can be differentiated based upon the difference of the time at which the blood flow detection intensity, or the blood concentration of the contrast agent, reaches a peak value.

[0011] In accordance with a third aspect, the present invention provides a blood flow imaging method for scanning and detecting blood flow infused with a contrast agent injected into a subject, and displaying the blood flow, comprising: displaying the blood flow in a predefined hue or gradation range before a hue etc. change time specified within a contrast agent flow-in period, and displaying, after the hue etc. change time, the blood flow in a hue or gradation range determined based on the relationship between the blood flow detection intensity and an in-flow threshold at the hue etc. change time.

[0012] In the blood flow imaging method of the third aspect, since the hue or gradation range for the time after the hue etc. change time is determined based on the relationship between the blood flow detection intensity and an in-flow threshold at the hue etc. change time, even if the arrival times or the blood concentration properties of the contrast agent are similar among a plurality of streams of blood flow, the hues or display gradations of the blood flow streams can be differentiated based upon the difference of the in-flow properties of the contrast agent.

[0013] In accordance with a fourth aspect, the present invention provides a blood flow imaging method for scanning and detecting blood flow infused with a contrast agent injected into a subject, and displaying the blood flow, comprising: displaying the blood flow in a predefined hue or gradation range before a hue etc. change time specified within a contrast agent flow-out period, and displaying, after the hue etc. change time, the blood flow in a hue or gradation range determined based on the relationship between the blood flow detection intensity and an out-flow threshold at the hue etc. change time.

[0014] In the blood flow imaging method of the fourth aspect, since the hue or gradation range for the time after the hue etc. change time is determined based on the relationship between the blood flow detection intensity and an out-flow threshold at the hue etc. change time, even if the arrival times or the blood concentration properties of the contrast agent are similar among a plurality of streams of blood flow, the hues or display gradations of the blood flow streams can be differentiated based upon the difference of the out-flow properties of the contrast agent.

[0015] In accordance with a fifth aspect, the present invention provides a blood flow imaging method for scanning and detecting blood flow infused with a contrast agent injected

into a subject, and displaying the blood flow, comprising: producing a plurality of blood flow images corresponding to different times in different hues or gradation ranges, and displaying a blood flow image in which the plurality of blood flow images are superimposed.

[0016] In the blood flow imaging method of the fifth aspect, since a plurality of blood flow images having different hues or gradation ranges depending upon the time are superimposed, a plurality of streams of blood flow having different arrival times of the contrast agent can be displayed in different colors or gradations on one still image, and visibility is improved.

[0017] In accordance with a sixth aspect, the present invention provides a blood flow imaging apparatus comprising: scanning means for scanning a subject to detect blood flow infused with a contrast agent; blood flow image producing means for producing a blood flow image in which at least one of the hue and gradation range of a display region representing the blood flow is changed in one or more steps in the course of time; and blood flow image displaying means for displaying the blood flow image.

[0018] In the blood flow imaging apparatus of the sixth aspect, the blood flow imaging method of the first aspect can be suitably implemented.

[0019] In accordance with a seventh aspect, the present invention provides a blood flow imaging apparatus comprising: scanning means for scanning a subject to detect blood flow infused with a contrast agent; blood flow image producing means for producing a blood flow image in which a plurality of streams of blood flow having different times at which the blood flow detection intensity reaches a peak value are represented in different hues or gradation ranges; and blood flow image displaying means for displaying the blood flow image.

[0020] In the blood flow imaging apparatus of the seventh aspect, the blood flow imaging method of the second aspect can be suitably implemented.

[0021] In accordance with an eighth aspect, the present invention provides a blood flow imaging apparatus comprising: scanning means for scanning a subject to detect blood flow infused with a contrast agent; hue etc. change time specifying means for use by an operator to specify a hue etc. change time within a contrast agent in-flow period; blood flow image producing means for producing a blood flow image in which the blood flow is represented in a predefined hue or gradation range before the hue etc. change time, and producing a blood flow image in which the blood flow is represented, after the hue etc. change time, in a hue or gradation range determined based on the relationship between the blood flow detection intensity and an in-flow threshold at the hue etc. change time; and blood flow image displaying means for displaying the blood flow image.

[0022] In the blood flow imaging apparatus of the eighth aspect, the blood flow imaging method of the third aspect can be suitably implemented.

[0023] In accordance with a ninth aspect, the present invention provides a blood flow imaging apparatus comprising: scanning means for scanning a subject to detect blood flow infused with a contrast agent; hue etc. change time specifying means for use by an operator to specify a hue etc.

change time within a contrast agent out-flow period; blood flow image producing means for producing a blood flow image in which the blood flow is represented in a predefined hue or gradation range before the hue etc. change time, and producing a blood flow image in which the blood flow is represented, after the hue etc. change time, in a hue or gradation range determined based on the relationship between the blood flow detection intensity and an out-flow threshold at the hue etc. change time; and blood flow image displaying means for displaying the blood flow image.

[0024] In the blood flow imaging apparatus of the ninth aspect, the blood flow imaging method of the fourth aspect can be suitably implemented.

[0025] In accordance with a tenth aspect, the present invention provides a blood flow imaging apparatus comprising: scanning means for scanning a subject to detect blood flow infused with a contrast agent; blood flow image producing means for producing a plurality of blood flow images corresponding to different times in different hues or gradation ranges, and producing a blood flow image in which the plurality of blood flow images are superimposed; and blood flow image displaying means for displaying the superimposed blood flow image.

[0026] In the blood flow imaging apparatus of the tenth aspect, the blood flow imaging method of the fifth aspect can be suitably implemented.

[0027] In accordance with an eleventh aspect, the present invention provides an ultrasonic diagnostic apparatus comprising: an ultrasonic probe; a transceiver section for transmitting ultrasound from the ultrasonic probe, acquiring an ultrasonic echo and outputting a received signal based on the ultrasonic echo; blood flow image producing means for, based on the received signal, producing a blood flow image in which at least one of the hue and gradation range of a display region representing blood flow infused with a contrast agent is changed in one or more steps in the course of time; and blood flow image displaying means for displaying the blood flow image.

[0028] In the ultrasonic diagnostic apparatus of the eleventh aspect, the blood flow imaging method of the first aspect can be suitably implemented.

[0029] In accordance with a twelfth aspect, the present invention provides an ultrasonic diagnostic apparatus comprising: an ultrasonic probe; a transceiver section for transmitting ultrasound from the ultrasonic probe, acquiring an ultrasonic echo and outputting a received signal based on the ultrasonic echo; blood flow image producing means for, based on the received signal, producing a blood flow image in which a plurality of streams of blood flow having different times at which the blood flow detection intensity reaches a peak value are represented in different hues or gradation ranges; and blood flow image displaying means for displaying the blood flow image.

[0030] In the ultrasonic diagnostic apparatus of the twelfth aspect, the blood flow imaging method of the second aspect can be suitably implemented.

[0031] In accordance with a thirteenth aspect, the present invention provides an ultrasonic diagnostic apparatus comprising: an ultrasonic probe; a transceiver section for transmitting ultrasound from the ultrasonic probe, acquiring an

ultrasonic echo and outputting a received signal based on the ultrasonic echo; hue etc. change time specifying means for use by an operator to specify a hue etc. change time within a contrast agent in-flow period; blood flow image producing means for, based on the received signal, producing a blood flow image in which the blood flow is represented in a predefined hue or gradation range before the hue etc. change time, and producing a blood flow image in which the blood flow is represented, after the hue etc. change time, in a hue or gradation range determined based on the relationship between the blood flow detection intensity and an in-flow threshold at the hue etc. change time; and blood flow image displaying means for displaying the blood flow image.

[0032] In the ultrasonic diagnostic apparatus of the thirteenth aspect, the blood flow imaging method of the third aspect can be suitably implemented.

[0033] In accordance with a fourteenth aspect, the present invention provides an ultrasonic diagnostic apparatus comprising: an ultrasonic probe; a transceiver section for transmitting ultrasound from the ultrasonic probe, acquiring an ultrasonic echo and outputting a received signal based on the ultrasonic echo; hue etc. change time specifying means for use by an operator to specify a hue etc. change time within a contrast agent out-flow period; blood flow image producing means for, based on the received signal, producing a blood flow image in which the blood flow is represented in a predefined hue or gradation range before the hue etc. change time, and producing a blood flow image in which the blood flow is represented, after the hue etc. change time, in a hue or gradation range determined based on the relationship between the blood flow detection intensity and an out-flow threshold at the hue etc. change time; and blood flow image displaying means for displaying the blood flow image.

[0034] In the ultrasonic diagnostic apparatus of the fourteenth aspect, the blood flow imaging method of the fourth aspect can be suitably implemented.

[0035] In accordance with a fifteenth aspect, the present invention provides an ultrasonic diagnostic apparatus comprising: an ultrasonic probe; a transceiver section for transmitting ultrasound from the ultrasonic probe, acquiring an ultrasonic echo and outputting a received signal based on the ultrasonic echo; blood flow image producing means for, based on the received signal, producing a plurality of blood flow images corresponding to different times in different hues or gradation ranges, and producing a blood flow image in which the plurality of blood flow images are superimposed; and blood flow image displaying means for displaying the superimposed blood flow image.

[0036] In the ultrasonic diagnostic apparatus of the fifteenth aspect, the blood flow imaging method of the fifth aspect can be suitably implemented.

[0037] In accordance with a sixteenth aspect, the present invention provides the ultrasonic diagnostic apparatus of the aforementioned configuration, wherein the blood flow image producing means produces the blood flow image synchronously with an electrocardiogram.

[0038] In the ultrasonic diagnostic apparatus of the sixteenth aspect, the blood flow image can be produced synchronously with the cardiac cycle.

[0039] According to the blood flow imaging method, blood flow imaging apparatus and ultrasonic diagnostic apparatus of the present invention, a plurality of streams of blood flow having different contrast agent arrival times or blood concentration properties can be displayed in different colors or gradations. Therefore, in diagnosing hepatoma, for example, the hepatic artery (blood flow in an artery system) and the portal vein (blood flow in a vein system) can be easily discerned, and discrimination between malignant and benign tumors and determination of the degree of differentiation can be achieved more exactly.

[0040] Moreover, blood flow corresponding to a plurality of times can be combined and displayed in one still image, and the efficiency in interpretation of the image by a physician can be improved.

[0041] Further objects and advantages of the present invention will be apparent from the following description of the preferred embodiments of the invention as illustrated in the accompanying drawings.

BRIEF DESCRIPTION OF THE DRAWINGS

[0042] FIG. 1 is a block diagram showing an example of a conventional ultrasonic diagnostic apparatus.

[0043] FIG. 2 is a block diagram showing an ultrasonic diagnostic apparatus in accordance with a first embodiment.

[0044] FIG. 3 is an explanatory diagram showing the hue of a blood flow image in the ultrasonic diagnostic apparatus of FIG. 2.

[0045] FIG. 4 is a flow chart showing blood flow imaging processing by the ultrasonic diagnostic apparatus of FIG. 2.

[0046] FIG. 5 is an explanatory diagram showing the relationship between the blood flow power properties and the hue of a blood flow image in the ultrasonic diagnostic apparatus of FIG. 2.

[0047] FIG. 6 is an explanatory diagram showing the transition of a blood flow image in the ultrasonic diagnostic apparatus of FIG. 2.

[0048] FIG. 7 is a block diagram showing an ultrasonic diagnostic apparatus in accordance with a second embodiment.

[0049] FIG. 8 is an explanatory diagram showing the relationship between the blood flow power properties and the hue of a blood flow image in the ultrasonic diagnostic apparatus of FIG. 7.

[0050] FIG. 9 is an explanatory diagram showing a blood flow image in a power peak hold mode in the ultrasonic diagnostic apparatus of FIG. 7.

[0051] FIG. 10 is a block diagram showing an ultrasonic diagnostic apparatus in accordance with a third embodiment.

[0052] FIG. 11 is an explanatory diagram showing the relationship between the blood flow power properties and the hue of a blood flow image in a flow-in threshold hold mode.

[0053] FIG. 12 is an explanatory diagram showing the transition of a blood flow image in the flow-in threshold hold mode.

[0054] FIG. 13 is an explanatory diagram showing the relationship between the blood flow power properties and the hue of a blood flow image in a flow-out threshold hold mode.

[0055] FIG. 14 is an explanatory diagram showing the transition of a blood flow image in the flow-out threshold hold mode.

[0056] FIG. 15 is an explanatory diagram showing a blood flow image in a superimposition mode.

[0057] FIG. 16 is an explanatory diagram showing the relationship between the blood flow power properties and the gradation of a blood flow image in a monochrome mode.

[0058] FIG. 17 is an explanatory diagram showing the transition of a blood flow image in the monochrome mode.

[0059] FIG. 18 is an explanatory diagram showing the hue of a blood flow image in a hue gradation mode.

DETAILED DESCRIPTION OF THE INVENTION

[0060] The present invention will now be described in more detail with reference to several embodiments shown in the accompanying drawings. It should be noted that the present invention is not limited to these embodiments.

First Embodiment

[0061] FIG. 2 is a block diagram showing an ultrasonic diagnostic apparatus in accordance with a first embodiment of the present invention.

[0062] The ultrasonic diagnostic apparatus 100 comprises: an ultrasonic probe 1; a transceiver section 2 for transmitting ultrasound from the ultrasonic probe 1, acquiring an ultrasonic echo and outputting a received signal e based on the ultrasonic echo; a quadrature detector section 3 for outputting in-phase (I) and quadrature (Q) components of the received echo signal e ; a power calculating section 4 for calculating the power P of blood flow, i.e., calculating the sum of squares of the in-phase and quadrature components I and Q; a timer 11 for measuring an elapsed time t from a reference time; a blood flow image producing section 5 for producing a blood flow image $G1$ in which the hue is changed before and after the elapsed time t reaches a hue change time t_c and the brightness varies depending upon the power P ; an operating section 12 for resetting the timer 11 and specifying the hue change time t_c ; and a display 6 such as a CRT (cathode ray tube) device.

[0063] Specifically, the blood flow image producing section 5 sets the hue to 'Red' in a period $t < t_c$ and to 'Blue' in a period $t \geq t_c$, and raises the brightness of the color as the power P becomes larger, as shown in FIG. 3. It should be noted that two or more hue change times t_c may be specified. For example, it is possible to specify hue change times t_{c1} and t_{c2} ($t_{c1} < t_{c2}$), set the hue to 'Red' in a period $t < t_{c1}$, to 'Yellow' in a period $t_{c1} \leq t < t_{c2}$, and to 'Blue' in a period $t \geq t_{c2}$.

[0064] FIG. 4 is a flow chart showing blood flow imaging processing by the ultrasonic diagnostic apparatus 100 of FIG. 2.

[0065] In Step S1, an operator (ordinarily, a physician or a technician) specifies the hue change time t_c using the

operating section 12. Although the hue change time t_c may be different depending upon the object blood flow, it is empirically determined in a range between, for example, several seconds and ten seconds or more. The hue change time t_c may be specified or changed after starting a scan (after Step S3 below).

[0066] In Step S2, the operator resets the timer 11 using the operating section 11. The timer 11 measures an elapsed time t after the resetting.

[0067] In Step S3, a scan of the interior of the subject is started.

[0068] A contrast agent is injected into the subject immediately after Step S2, or immediately before or after Step S3.

[0069] In Step S4, the process goes to Step S5 in a period $t < t_c$, and when $t \geq t_c$ is reached, the process goes to Step S7.

[0070] In Step S5, the blood flow image producing section 5 produces a blood flow image $G1$ in red and displays the image $G1$ on the display 6.

[0071] In Step S6, if the termination of the process is not prescribed, the process goes back to Step S4; otherwise, the process is terminated.

[0072] In Step S7, the blood flow image producing section 5 produces the blood flow image $G1$ in blue and displays the image $G1$ on the display 6.

[0073] In Step S8, if the termination of the process is not prescribed, the process goes back to Step S7; otherwise, the process is terminated.

[0074] FIG. 5 shows an example of the properties of the power P of blood flow $\alpha 1$ and blood flow $\beta 1$ and the hue with respect to the elapsed time t . It should be noted that the power P varies depending upon the blood concentration of the contrast agent.

[0075] In the period $t < t_c$, a blood flow image $G1$ in which the power P of the blood flow $\alpha 1$ and $\beta 1$ is reflected is displayed in red. For example, at an elapsed time t_1 at which the power P of the blood flow $\alpha 1$ reaches a peak value, the blood flow $\alpha 1$ is displayed in bright red, as shown in FIG. 6(a).

[0076] In the period $t \geq t_c$, a blood flow image $G1$ in which the power P of the blood flow $\alpha 1$ and $\beta 1$ is reflected is displayed in blue. For example, at the elapsed time $t = t_c$, the blood flow $\alpha 1$ and $\beta 1$ are displayed in dark blue, as shown in FIG. 6(b). At an elapsed time t_2 at which the power P of the blood flow $\beta 1$ reaches a peak value, the blood flow $\beta 1$ is displayed in bright blue, as shown in FIG. 6(c).

[0077] According to the ultrasonic diagnostic apparatus 100 of the first embodiment, since a blood flow image $G1$ in which the hue is changed before and after the elapsed time t reaches the hue change time t_c is displayed, blood flow $\alpha 1$ and blood flow $\beta 1$ having different arrival times of the contrast agent can be properly discerned.

Second Embodiment

[0078] FIG. 7 is a block diagram showing an ultrasonic diagnostic apparatus in accordance with a second embodiment of the present invention.

[0079] The ultrasonic diagnostic apparatus **200** comprises: an ultrasonic probe **1**; a transceiver section **2**; a quadrature detector section **3**; a power calculating section **4** for calculating the power P of blood flow; a power peak holding section **21** for comparing the latest power P and a predecessor peak value P_0 , and outputting the larger one as a peak value P' and an elapsed time t' corresponding to the peak value P' ; a predecessor power/elapsed time keeping section **22** for keeping the predecessor peak value P_0 and the corresponding elapsed time 'to' and outputting these values to the power peak holding section **21**; a timer **11** for measuring an elapsed time t from a reference time; a blood flow image producing section **25** for producing a power peak hold blood flow image G_2 in which the hue is changed before and after the elapsed time t' reaches a hue change time t_c and the brightness varies depending upon the peak value P' ; an operating section **12** for resetting the timer **11** and specifying the hue change time t_c ; and a display **6**.

[0080] The power peak holding section **21** compares the latest power P and the predecessor peak value P_0 , and if $P > P_0$, the section **21** outputs the power P as a peak value P' and an elapsed time t' corresponding to the power P . If $P \leq P_0$, the section **21** outputs the predecessor peak value P_0 as the peak value P' and an elapsed time t' corresponding to the predecessor peak value P_0 .

[0081] The blood flow image producing section **25** produces a power peak hold blood flow image G_2 in which the hue of the blood flow is set to red if the elapsed time $t' < t_c$ and is set to blue if $t' \geq t_c$, and displays the image G_2 on the display **6**.

[0082] FIG. 8 shows an example of the properties of the power P of blood flow α_2 in the hepatic artery and blood flow β_2 in the portal vein, and the hue with respect to the elapsed time t .

[0083] An elapsed time t_1 at which the power P of the blood flow α_2 in the hepatic artery reaches a peak value p_1 is $t_1 < t_c$. The elapsed time t_1 is, for example, 10 seconds. The hue change time t_c is, for example, 12.5 seconds.

[0084] An elapsed time t_2 at which the power P of the blood flow β_2 in the portal vein reaches a peak value p_2 is $t_2 \geq t_c$. The elapsed time t_2 is, for example, 15 seconds.

[0085] Therefore, as shown FIG. 9, in the power peak hold blood flow image G_2 after the elapsed time t_2 , the blood flow α_2 in the hepatic artery continues to be displayed in bright red (i.e., at the brightness corresponding to the peak value p_1), and in addition, the blood flow β_2 in the portal vein is displayed in bright blue (i.e., at the brightness corresponding to the peak value p_2).

[0086] According to the ultrasonic diagnostic apparatus **200** of the second embodiment, even if a time period in which a plurality of streams of blood flow are simultaneously infused with the contrast agent is long, a power peak hold blood flow image G_2 can be displayed in which the hues of the blood flow streams are differentiated depending upon the difference of the time at which the power P of the blood flow reaches a peak value. For example, the hepatic artery blood flow α_2 and the portal vein blood flow β_2 can be displayed in different colors.

Third Embodiment

[0087] FIG. 10 is a block diagram showing an ultrasonic diagnostic apparatus in accordance with a third embodiment of the present invention.

[0088] The ultrasonic diagnostic apparatus **300** comprises: an ultrasonic probe **1**; a transceiver section **2**; a quadrature detector section **3**; a power calculating section **4** for calculating the power P of blood flow; a timer **11** for measuring an elapsed time t from a reference time; a synchronization section **31** for resetting the elapsed time t synchronously with an R-wave supplied from an ECG (electrocardiograph); a blood flow image producing section **5** for producing a blood flow image G_1 in which the hue is changed before and after the elapsed time t reaches a hue change time t_c and the brightness varies depending upon the power P ; a power/elapsed time storing section **32** for continuously recording the power P and the corresponding elapsed time t ; a multi-display-mode blood flow image producing section **33** for producing blood flow images G_1 - G_7 in several display modes; an operating section **34** having the functions which will be described below; a switch **35** for selecting between outputs from the blood flow image producing section **5** and the multi-display-mode blood flow image producing section **33**; and a display **6**.

[0089] The operating section **34** receives instructions from the operator, and resets the timer **11**. The section **34** also outputs a hue change time t_c , a gradation change time t_c' , a display mode selection signal M , an in-flow threshold P_{THin} and an out-flow threshold P_{THout} (the details of which will be described later). Moreover, the section **34** prescribes timing T_{iw} for gathering the power P into the power/elapsed time storing section **32** before and during a scan. (The gathering may be performed throughout a scan.) Furthermore, the operating section **34** outputs a power readout time t_{ir} for reading out a power P_{ir} stored in the power/elapsed time storing section **32**.

[0090] The multi-display-mode blood flow image producing section **33** comprises a through mode processing section **331**, a peak hold mode processing section **332**, an in-flow threshold hold mode processing section **333**, an out-flow threshold hold mode processing section **334**, a superimposition mode processing section **335**, a monochrome mode processing section **336** and a hue gradation mode processing section **337**. The operation of these mode processing sections will be described later.

[0091] The operation of the ultrasonic diagnostic apparatus **300** will now be described. The operation when the switch **35** selects the output from the blood flow image producing section **5** is the same as that of the ultrasonic diagnostic apparatus **100** (see FIG. 2) in accordance with the first embodiment, and explanation thereof will be omitted.

[0092] When the operator selects a display mode using the operating section **34**, a display mode selection signal M is sent to the multi-display-mode blood flow image producing section **33**.

[0093] When a through mode is selected, the power P_{ir} for each pixel on a screen is read out for each frame from the power/elapsed time storing section **32**, and a blood flow image G_1 is produced at the through mode processing section **331**. The blood flow image G_1 is the same as that produced by the blood flow image producing section **5**.

[0094] When a peak hold mode is selected, the power P_{ir} is read out for each frame, and a blood flow image G_2 is produced at the peak hold mode processing section **332**. The blood flow image G_2 is the same as that in the ultrasonic diagnostic apparatus **200** (see FIG. 7) in accordance with the second embodiment.

[0095] When an in-flow threshold hold mode is selected, the power P_{ir} is read out for each frame, and an in-flow threshold hold mode blood flow image G3 is produced at the in-flow threshold hold mode processing section 333. As shown in FIG. 11, in the in-flow threshold hold mode, the hue change time t_c is specified within a period in which the contrast agent flows in, and the hue is set to red in a blood flow reproduction period $t < t_c$; the hue remains red in a blood flow reproduction period $t \geq t_c$ if the power $P \geq$ in-flow threshold P_{THin} , and the hue is changed to blue if the power $P <$ in-flow threshold P_{THin} . Therefore, when the blood flow at the elapsed time $t=t1$ ($t1 < t_c$) is reproduced, the blood flow $\alpha3$ is displayed in dark red, as shown in FIG. 12(a). When the blood flow at the elapsed time $t=t_c$ is reproduced, the blood flow $\alpha3$ is displayed in bright red and the blood flow $\beta3$ is displayed in dark blue, as shown in FIG. 12(b). When the blood flow at the elapsed time $t=t2$ ($t2 > t_c$) is reproduced, the blood flow $\alpha3$ is displayed in bright red and the blood flow $\beta3$ is displayed in bright blue, as shown in FIG. 12(c). Thus, even if the times at which the powers P of the blood flow $\alpha3$ and $\beta3$ reach peak values are close to each other, the blood flow $\alpha3$ and $\beta3$ can be displayed in different colors depending upon whether or not the power P at the hue change time t_c is equal to or larger than the in-flow threshold P_{THin} .

[0096] When an out-flow threshold hold mode is selected, the power P_{ir} is read out for each frame, and an out-flow threshold hold mode blood flow image G4 is produced at the out-flow threshold hold mode processing section 334. As shown in FIG. 13, in the out-flow threshold hold mode, the hue change time t_c is specified within a period in which the contrast agent flows out, and the hue is set to red in a blood flow reproduction period $t < t_c$; the hue remains red in a blood flow reproduction period $t \geq t_c$ if the power $P \leq$ out-flow threshold P_{THout} , and the hue is changed to blue if the power $P >$ out-flow threshold P_{THout} . Therefore, when the blood flow at the elapsed time $t=t1$ ($t1 < t_c$) is reproduced, the blood flow $\alpha4$ is displayed in bright red and the blood flow $\beta4$ is displayed in rather bright red, as shown in FIG. 14(a). When the blood flow at the elapsed time $t=t_c$ is reproduced, the blood flow $\alpha4$ is displayed in rather bright blue and the blood flow $\beta4$ is displayed in rather dark red, as shown in FIG. 14(b). When the blood flow at the elapsed time $t=t2$ ($t2 > t_c$) is reproduced, the blood flow $\alpha4$ is displayed in rather dark blue and the blood flow $\beta4$ is displayed in dark red, as shown in FIG. 14(c). Thus, even if the times at which the powers P of the blood flow $\alpha4$ and $\beta4$ reach peak values are close to each other, the blood flow $\alpha4$ and $\beta4$ can be displayed in different colors depending upon whether or not the power P at the hue change time t_c is equal to or smaller than the out-flow threshold P_{THout} .

[0097] When a superimposition mode is selected, a power P_{ir} and a power readout time t_{ir} corresponding to the elapsed times $t1$ and $t2$ specified by the operator are read out from the power/elapsed time storing section 32, and sent to the superimposition mode processing section 335. The superimposition mode processing section 335 produces blood flow images G1(t1) and G1(t2) corresponding to the elapsed times $t1$ and $t2$ by processing similar to that in the blood flow image producing section 5, and produces a superimposition mode blood flow image G5 in which the blood flow images G1 are superimposed. For example, the hepatic artery blood flow $\alpha2$ and the portal vein blood flow $\beta2$ having such power properties as exemplified in FIG. 8 are to be displayed, the

hue of the hepatic artery blood flow $\alpha2$ in the blood flow image G1(t1) is bright red, as shown in FIG. 15(a). The hues of the hepatic artery blood flow $\alpha2$ and the portal vein blood flow $\beta2$ in the blood flow image G1(t2) are bright blue, as shown in FIG. 15(b). Therefore, the superimposition mode blood flow image G5 is a still image with the hepatic artery blood flow $\alpha2$ displayed in bright purple (i.e., by additive mixing of bright red and blue), and with the portal vein blood flow $\beta2$ displayed in bright blue, as shown in FIG. 15(c). It should be noted that, if the superimposition is achieved by a simple addition on display values, the resulting display value may saturate; and therefore normalization is applied so that the display value falls within a normal range. Moreover, the superimposition region having different hues (the purple region in the above example) may be displayed in a hue different from one obtained by the additive mixing (e.g., in yellow).

[0098] When a monochrome mode is selected, the power P_{ir} is read out for each frame, and a monochrome mode blood flow image G6 is produced at the monochrome mode processing section 336.

[0099] As shown in FIG. 16, in the monochrome mode, a grayscale having 256 gradations, for example, is divided into two gradation ranges including a low gradation grayscale and a high gradation grayscale. The low gradation grayscale is used for representing blood flow before the elapsed time t reaches the gradation change time t_c' , and the high gradation grayscale is used for representing blood flow after the elapsed time t has reached gradation change time t_c' . Therefore, when the blood flow at the elapsed time $t=t1$ ($t1 < t_c'$) is reproduced, the blood flow $\alpha1$ is displayed in dark gray, as shown in FIG. 17(a). When the blood flow at the elapsed time $t=t_c'$ is reproduced, the blood flow $\alpha1$ and $\beta1$ are displayed in rather light gray, as shown in FIG. 17(b). When the blood flow at the elapsed time $t=t2$ ($t2 > t_c'$) is reproduced, the blood flow $\beta1$ is displayed in light gray, as shown in FIG. 17(c). Thus, the blood flow $\alpha1$ and $\beta1$ can be properly discerned even in a monochrome image by using different grayscales before and after the gradation change time t_c' .

[0100] When a hue gradation mode is selected, the power P_{ir} is read out for each frame, and a hue gradation mode blood flow image G7 is produced at the hue gradation mode processing section 337.

[0101] As shown in FIG. 18, in the hue gradation mode, the hue is changed in multicolor with respect to the elapsed time t to display the blood flow. Specifically, the blood flow at the elapsed time $t=0$ is displayed in red, and the wavelength representing the hue becomes shorter with the elapsed time t . Thus, a plurality of streams of blood flow having different times of infusion by the contrast agent can be properly discerned from the variation in hue.

[0102] When the blood flow image is displayed using the multi-display-mode blood flow image producing section 33, the specification and change of the hue change time t_c , gradation change time t_c' , in-flow threshold P_{THin} , out-flow threshold P_{THout} , power readout time t_{ir} , and display mode may be performed in any period before, during or after scanning. Therefore, if the power property of the blood flow is different among types of the contrast agent and among subject individuals, a blood flow image suitable for interpretation by a physician can be displayed.

[0103] According to the ultrasonic diagnostic apparatus 300 of the third embodiment, a blood flow image G1 produced at the blood flow image producing section 5 can be displayed in real time. Moreover, blood flow images G1-G7 can be produced in several display modes (through mode, peak hold mode, in-flow threshold hold mode, out-flow threshold hold mode, superimposition mode, monochrome mode and hue gradation mode) even after scanning by reading the power P_{ir} etc. stored in the power/elapsed time storing section 32, and therefore a blood flow image suitable for interpretation by a physician can be displayed. Furthermore, the blood flow images G1-G7 can be produced to match the cardiac cycle by resetting the elapsed time t synchronously with an ECG.

Other Embodiments

[0104] The present invention is not limited to power Doppler blood flow imaging, but may be applied to blood flow imaging by a B-mode or ultrasonic harmonic technique.

[0105] Moreover, the present invention is not limited to an ultrasonic imaging apparatus, but may be generally applied to blood flow imaging apparatuses such as those for X-ray angiography, CT (computed tomography) angiography and MR (magnetic resonance) angiography. It should be noted that, in the X-ray angiography, the contrast agent can be applied to an arbitrary site using a catheter inserted into the subject, and therefore the hue and brightness of the blood flow may be changed corresponding to different times of possible infusion of the blood flow by the contrast agent, instead of corresponding to the elapsed time t (i.e., the time period after the contrast agent is intravenously injected).

[0106] Many widely different embodiments of the invention may be configured without departing from the spirit and the scope of the present invention. It should be understood that the present invention is not limited to the specific embodiments described in the specification, except as defined in the appended claims.

1. A blood flow imaging method for scanning and detecting blood flow infused with a contrast agent injected into a subject, and displaying the blood flow, comprising:

changing at least one of the hue and gradation range of a display region representing the blood flow in one or more steps in the course of time.

2. A blood flow imaging method for scanning and detecting blood flow infused with a contrast agent injected into a subject, and displaying the blood flow, comprising:

displaying a plurality of streams of blood flow having different times at which the blood flow detection intensity reaches a peak value, in different hues or gradation ranges.

3. A blood flow imaging method for scanning and detecting blood flow infused with a contrast agent injected into a subject, and displaying the blood flow, comprising:

displaying the blood flow in a predefined hue or gradation range before a hue etc. change time specified within a contrast agent flow-in period, and displaying, after said hue etc. change time, the blood flow in a hue or gradation range determined based on the relationship between the blood flow detection intensity and an in-flow threshold at said hue etc. change time.

4. A blood flow imaging method for scanning and detecting blood flow infused with a contrast agent injected into a subject, and displaying the blood flow, comprising:

displaying the blood flow in a predefined hue or gradation range before a hue etc. change time specified within a contrast agent flow-out period, and displaying, after said hue etc. change time, the blood flow in a hue or gradation range determined based on the relationship between the blood flow detection intensity and an out-flow threshold at said hue etc. change time.

5. A blood flow imaging method for scanning and detecting blood flow infused with a contrast agent injected into a subject, and displaying the blood flow, comprising:

producing a plurality of blood flow images corresponding to different times in different hues or gradation ranges, and displaying a blood flow image in which said plurality of blood flow images are superimposed.

6. A blood flow imaging apparatus comprising: scanning means for scanning a subject to detect blood flow infused with a contrast agent; blood flow image producing means for producing a blood flow image in which at least one of the hue and gradation range of a display region representing the blood flow is changed in one or more steps in the course of time; and blood flow image displaying means for displaying said blood flow image.

7. A blood flow imaging apparatus comprising: scanning means for scanning a subject to detect blood flow infused with a contrast agent; blood flow image producing means for producing a blood flow image in which a plurality of streams of blood flow having different times at which the blood flow detection intensity reaches a peak value are represented in different hues or gradation ranges; and blood flow image displaying means for displaying said blood flow image.

8. A blood flow imaging apparatus comprising: scanning means for scanning a subject to detect blood flow infused with a contrast agent; hue etc. change time specifying means for use by an operator to specify a hue etc. change time within a contrast agent in-flow period; blood flow image producing means for producing a blood flow image in which the blood flow is represented in a predefined hue or gradation range before said hue etc. change time, and producing a blood flow image in which the blood flow is represented, after said hue etc. change time, in a hue or gradation range determined based on the relationship between the blood flow detection intensity and an in-flow threshold at said hue etc. change time; and blood flow image displaying means for displaying said blood flow image.

9. A blood flow imaging apparatus comprising: scanning means for scanning a subject to detect blood flow infused with a contrast agent; hue etc. change time specifying means for use by an operator to specify a hue etc. change time within a contrast agent out-flow period; blood flow image producing means for producing a blood flow image in which the blood flow is represented in a predefined hue or gradation range before said hue etc. change time, and producing a blood flow image in which the blood flow is represented, after said hue etc. change time, in a hue or gradation range determined based on the relationship between the blood flow detection intensity and an out-flow threshold at said hue etc. change time; and blood flow image displaying means for displaying said blood flow image.

10. A blood flow imaging apparatus comprising: scanning means for scanning a subject to detect blood flow infused

with a contrast agent; blood flow image producing means for producing a plurality of blood flow images corresponding to different times in different hues or gradation ranges, and producing a blood flow image in which said plurality of blood flow images are superimposed; and blood flow image displaying means for displaying said superimposed blood flow image.

11. An ultrasonic diagnostic apparatus comprising: an ultrasonic probe; a transceiver section for transmitting ultrasound from said ultrasonic probe, acquiring an ultrasonic echo and outputting a received signal based on said ultrasonic echo; blood flow image producing means for, based on said received signal, producing a blood flow image in which at least one of the hue and gradation range of a display region representing blood flow infused with a contrast agent is changed in one or more steps in the course of time; and blood flow image displaying means for displaying said blood flow image.

12. An ultrasonic diagnostic apparatus comprising: an ultrasonic probe; a transceiver section for transmitting ultrasound from said ultrasonic probe, acquiring an ultrasonic echo and outputting a received signal based on said ultrasonic echo; blood flow image producing means for, based on said received signal, producing a blood flow image in which a plurality of streams of blood flow having different times at which the blood flow detection intensity reaches a peak value are represented in different hues or gradation ranges; and blood flow image displaying means for displaying said blood flow image.

13. An ultrasonic diagnostic apparatus comprising: an ultrasonic probe; a transceiver section for transmitting ultrasound from said ultrasonic probe, acquiring an ultrasonic echo and outputting a received signal based on said ultrasonic echo; hue etc. change time specifying means for use by an operator to specify a hue etc. change time within a contrast agent in-flow period; blood flow image producing means for, based on said received signal, producing a blood flow image in which the blood flow is represented in a predefined hue or gradation range before said hue etc. change time, and producing a blood flow image in which the

blood flow is represented, after said hue etc. change time, in a hue or gradation range determined based on the relationship between the blood flow detection intensity and an in-flow threshold at said hue etc. change time; and blood flow image displaying means for displaying said blood flow image.

14. An ultrasonic diagnostic apparatus comprising: an ultrasonic probe; a transceiver section for transmitting ultrasound from said ultrasonic probe, acquiring an ultrasonic echo and outputting a received signal based on said ultrasonic echo; hue etc. change time specifying means for use by an operator to specify a hue etc. change time within a contrast agent out-flow period; blood flow image producing means for, based on said received signal, producing a blood flow image in which the blood flow is represented in a predefined hue or gradation range before said hue etc. change time, and producing a blood flow image in which the blood flow is represented, after said hue etc. change time, in a hue or gradation range determined based on the relationship between the blood flow detection intensity and an out-flow threshold at said hue etc. change time; and blood flow image displaying means for displaying said blood flow image.

15. An ultrasonic diagnostic apparatus comprising: an ultrasonic probe; a transceiver section for transmitting ultrasound from said ultrasonic probe, acquiring an ultrasonic echo and outputting a received signal based on said ultrasonic echo; blood flow image producing means for, based on said received signal, producing a plurality of blood flow images corresponding to different times in different hues or gradation ranges, and producing a blood flow image in which said plurality of blood flow images are superimposed; and blood flow image displaying means for displaying said superimposed blood flow image.

16. The ultrasonic diagnostic apparatus as defined in any one of claims **11-15**, wherein said blood flow image producing means produces said blood flow image synchronously with an electrocardiogram.

* * * * *

专利名称(译)	血流成像方法，血流成像设备和超声诊断设备		
公开(公告)号	US20020103437A1	公开(公告)日	2002-08-01
申请号	US10/034850	申请日	2001-12-27
[标]申请(专利权)人(译)	JIBIKI TAKAO		
申请(专利权)人(译)	JIBIKI TAKAO		
当前申请(专利权)人(译)	JIBIKI TAKAO		
[标]发明人	JIBIKI TAKAO		
发明人	JIBIKI, TAKAO		
IPC分类号	A61B5/055 A61B8/00 A61B8/06 G01S7/52 G01S15/89 A61B8/02		
CPC分类号	A61B8/06 A61B8/461 A61B8/481 G01S7/52071 G01S7/52074 G01S15/8979 G01S15/8988		
优先权	2001025716 2001-02-01 JP		
其他公开文献	US6582370		
外部链接	Espacenet USPTO		

摘要(译)

为了适当地辨别具有不同造影剂到达时间或血液浓度特性的多个血流，超声诊断设备200包括：超声探头1；收发器部分2；正交检测器部分3；功率计算部分4，用于计算血流功率P；功率峰值保持部分21，用于比较最新功率P和前驱峰值 P_0 ，并输出较大值作为峰值P；和与峰值P；对应的经过时间t；前驱功率/经过时间保持部分22，用于保持前驱峰值 P_0 和相应的经过时间“到”并将这些值输出到功率峰值保持部分21；计时器11，用于从参考时间测量经过时间t；血流图像产生部分25，用于产生功率峰值保持血流图像G2，其中在经过时间t；到达色调改变时间 t_c 之前和之后改变色调，并且亮度根据峰值P；而变化；操作部分12用于重置计时器11并指定色调变化时间 t_c ；以及显示器6。例如，通过肝动脉和通过门静脉的血流可以以不同的颜色显示。

