



US 20030163045A1

(19) **United States**

(12) **Patent Application Publication**
Gatzke

(10) **Pub. No.: US 2003/0163045 A1**

(43) **Pub. Date: Aug. 28, 2003**

(54) **ULTRASOUND IMAGING ENHANCEMENT
TO CLINICAL PATIENT MONITORING
FUNCTIONS**

(21) Appl. No.: **10/086,007**

(22) Filed: **Feb. 28, 2002**

(75) Inventor: **Ronald D. Gatzke, Lexington, MA
(US)**

Publication Classification

(51) **Int. Cl.⁷ A61B 8/00**

(52) **U.S. Cl. 600/437**

Correspondence Address:

**PHILIPS INTELLECTUAL PROPERTY &
STANDARDS**

P.O. BOX 3001

BRIARCLIFF MANOR, NY 10510 (US)

(57) **ABSTRACT**

An apparatus includes an ultrasound imaging unit integrated into a patient monitoring system continuously generating ultrasound images from a patient and continuously extracting therefrom diagnostic data.

(73) Assignee: **Koninklijke Philips Electronics N.V.**

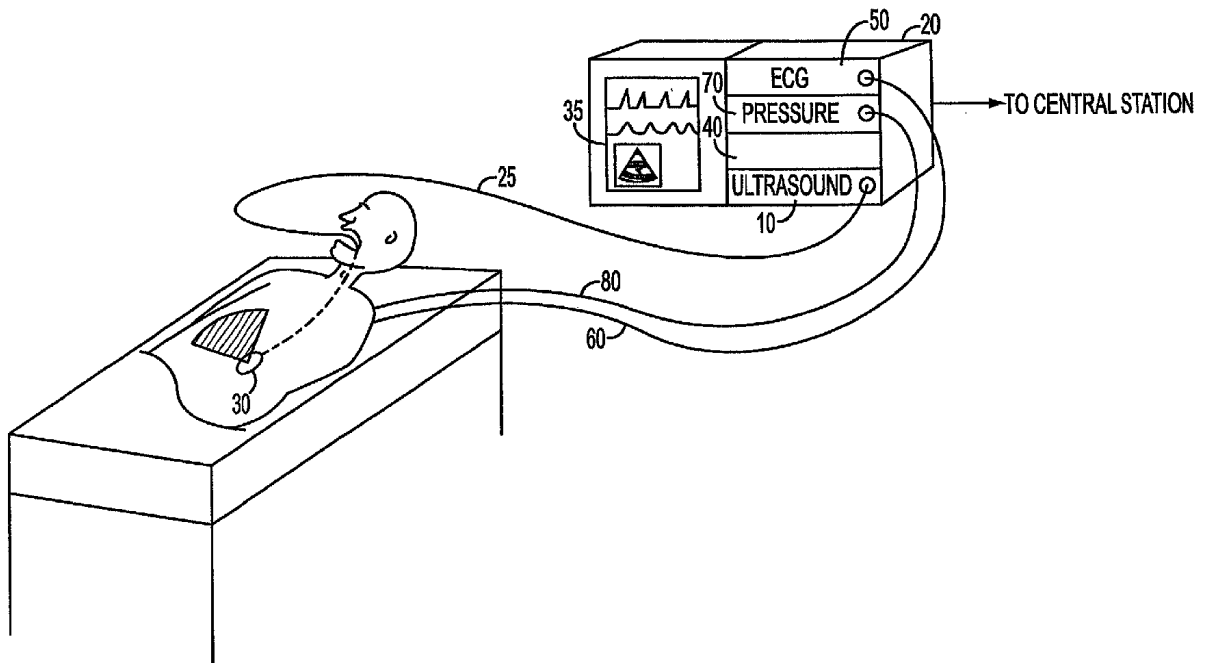

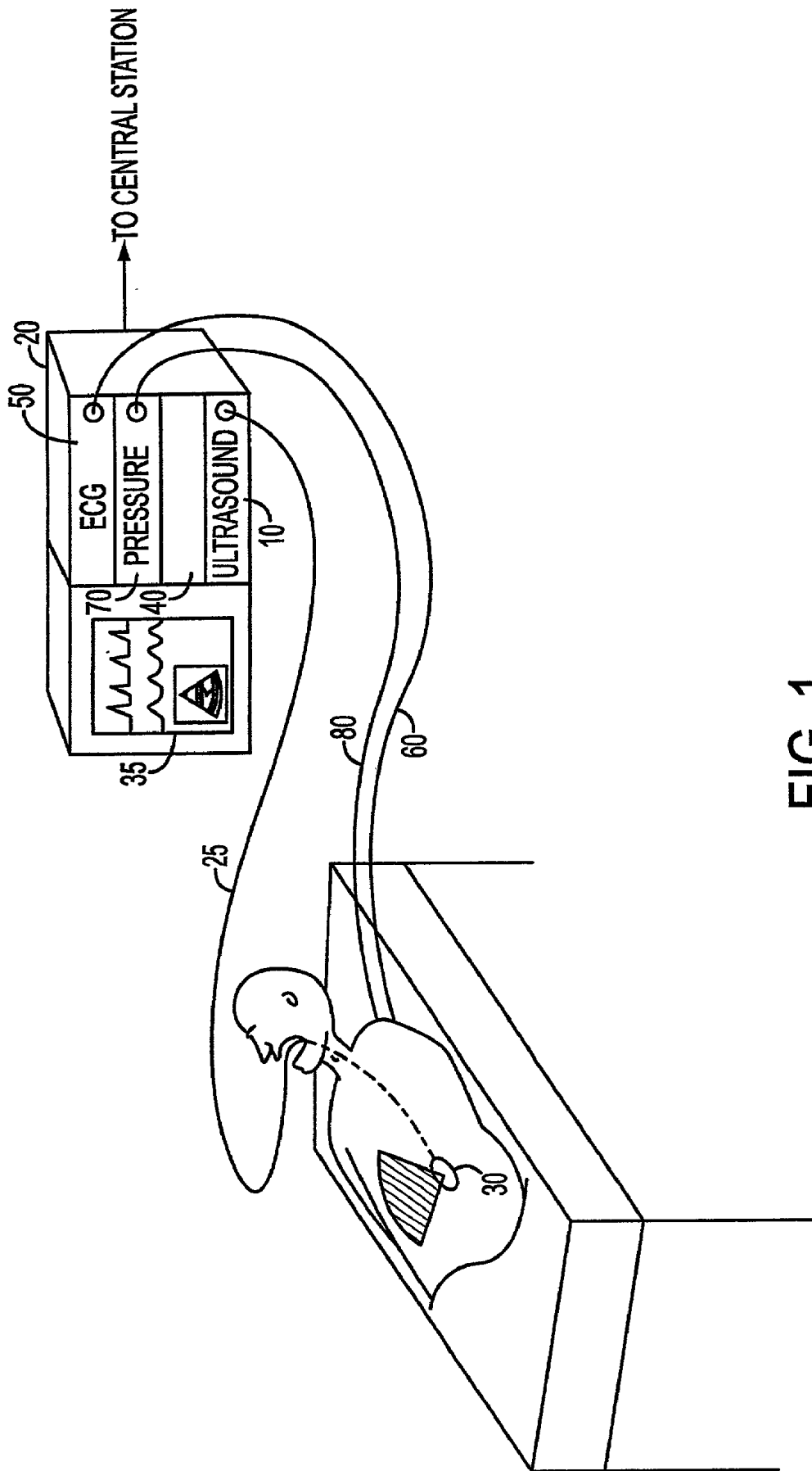

FIG. 1

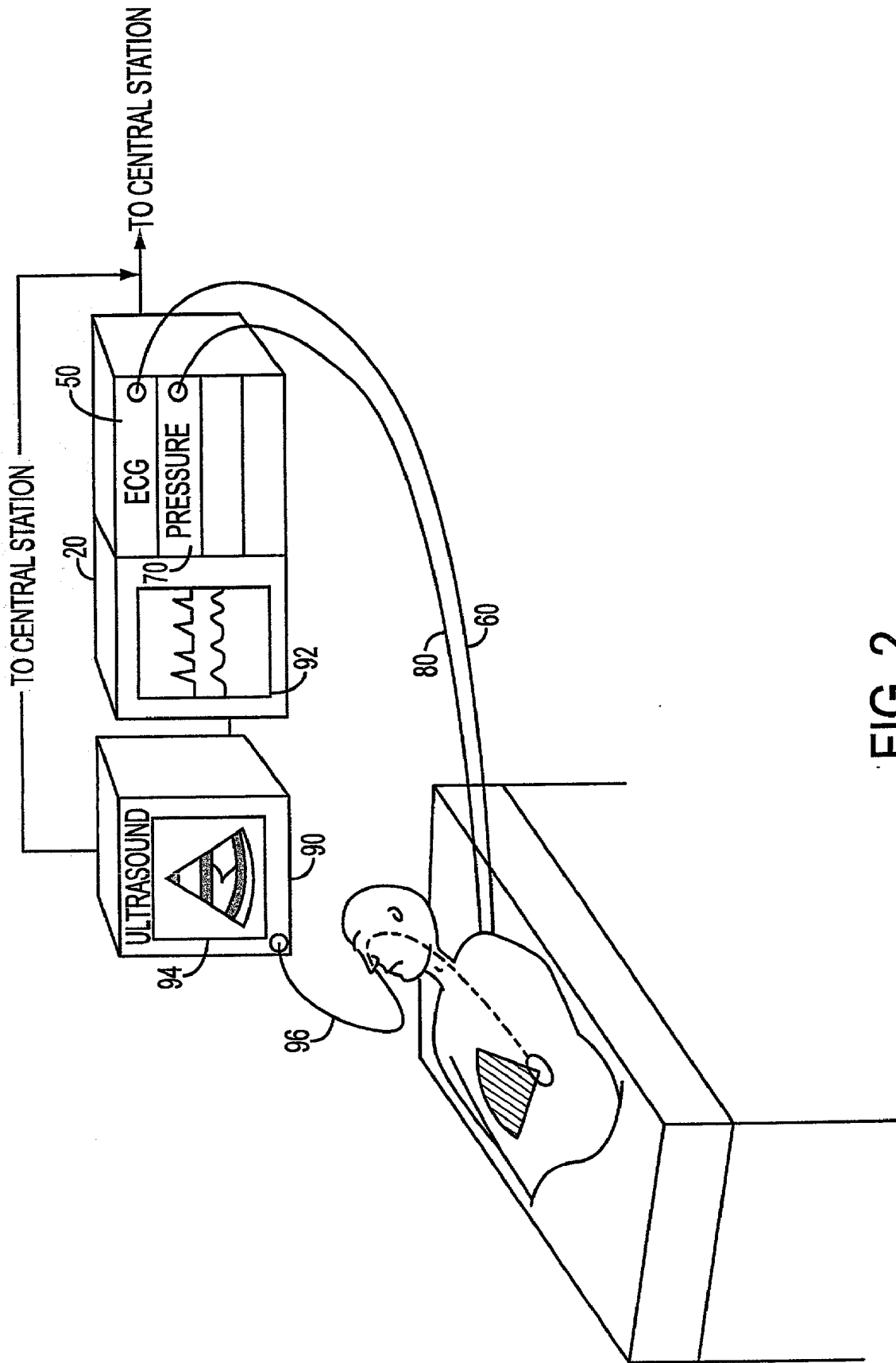
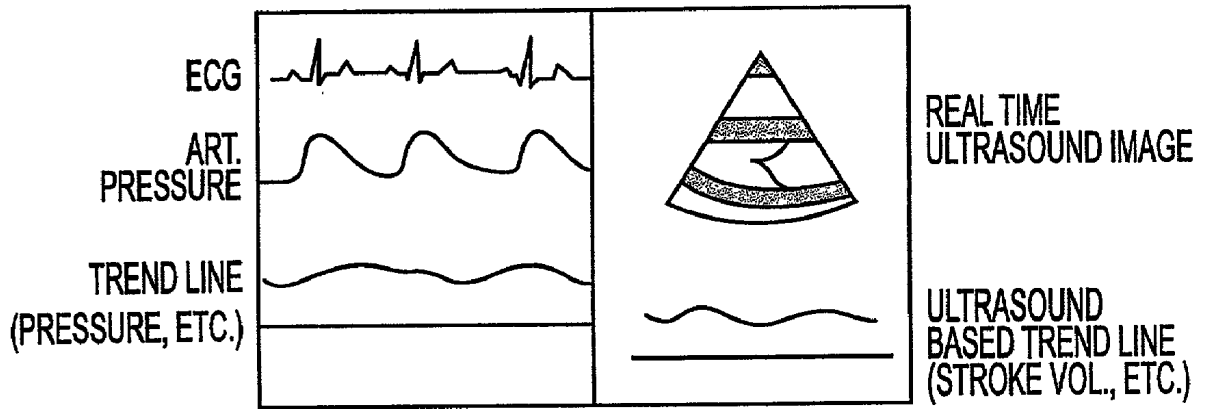
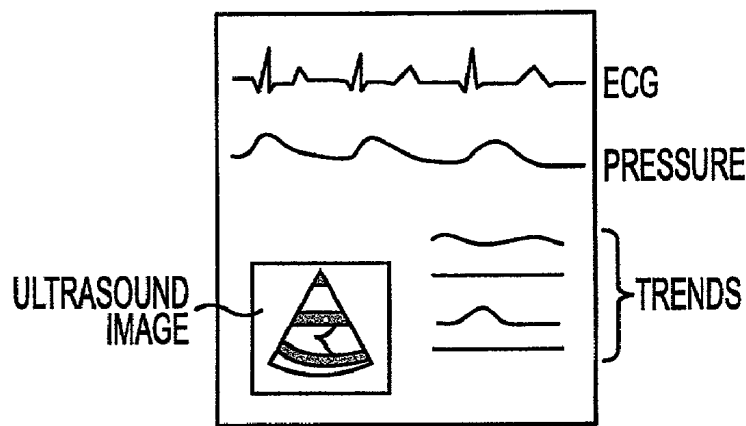

FIG. 2



SPLIT SCREEN
FIG. 3A



"WINDOW" IN "WINDOW"

FIG. 3B

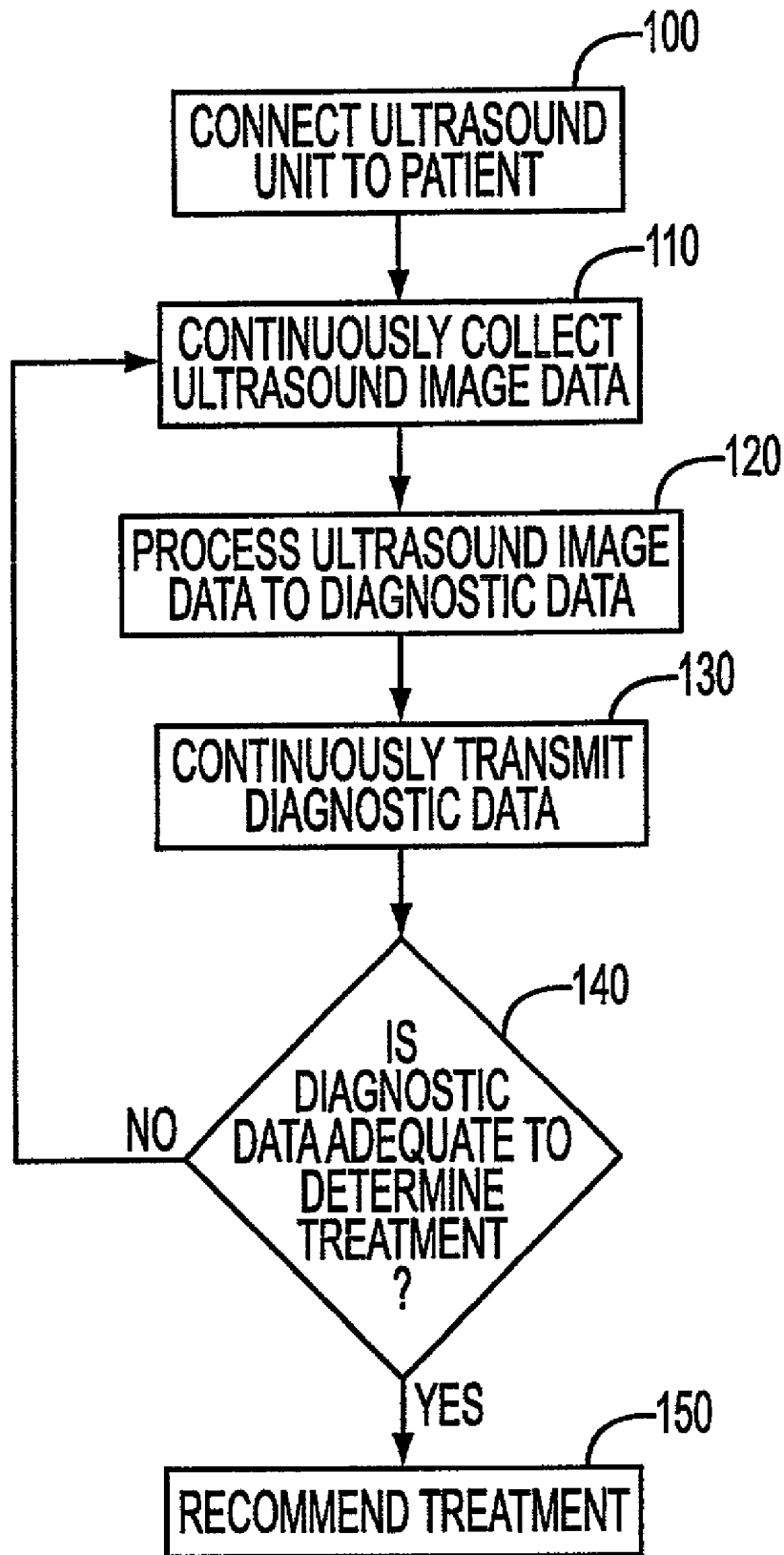

FIG. 4

ULTRASOUND IMAGING ENHANCEMENT TO CLINICAL PATIENT MONITORING FUNCTIONS

BACKGROUND OF THE INVENTION

[0001] Conventional ultrasound imaging systems used in a clinical setting are presently operated as standalone instruments, typically dedicated to diagnostic image acquisition. In this mode of operation, the ultrasound imaging system is normally used for a short period of time to diagnose a patient. The ultrasound imaging system is also a focused diagnostic system monitoring a particular pathology. An exception to this usage is the use of the transesophageal echocardiogram (TEE) probe in operating room environments for monitoring of cardiac activity during the duration of surgical procedures under active observation by clinical observers. TEE is a test that allows a cardiologist to view images of the internal structures of the heart and the heart's major vessel by inserting an ultrasound probe down the patient's throat or nose. For example, the patient is evaluated for atrial thrombi using the TEE probe.

[0002] However, although the TEE test may be four to six hours in duration, the heart is not monitored during the entire duration of the TEE test. Rather, intermittent image snapshots are obtained of the heart and the images are compared, for instance, image snapshots of the heart at pre-surgery are compared to images of the heart at post-surgery. Although, the conventional ultrasound imaging systems may be connected to a hospital's information network, the information network is used primarily for archiving the images and not for doing any diagnostic work or patient management. Further, size and complexity of present ultrasound imaging systems preclude their present use for long term patient monitoring applications.

[0003] Modern ultrasound imaging system design is moving towards systems of radically reduced size and complexity. Additionally, increased sophistication of control algorithms in ultrasound imaging systems is rendering the ultrasound imaging systems far more capable of self-adaptation to the imaging environment presented by individual subjects. Further, advancements in the art of information extraction from the ultrasound images allow for improved automatic determination of physiological functionality from the ultrasound image data.

[0004] Thus, it is necessary to develop an ultrasound imaging enhancement unit integrated into a patient monitoring system to allow physicians to continuously monitor physiological functions of a patient from images generated from the ultrasound imaging unit. Rather than limiting the user of the ultrasound imaging unit to diagnostic situations in an emergency room, the ultrasound imaging unit would allow monitoring of non-acute conditions of a patient, such as in intensive-care recovery situations.

SUMMARY OF THE INVENTION

[0005] In an exemplary embodiment, the present invention provides for an apparatus, including a patient monitoring system; and an ultrasound imaging unit integrated into the patient monitoring system continuously generating ultrasound images from a patient and continuously extracting therefrom diagnostic data.

[0006] The present invention also provides an apparatus including an apparatus, including a patient monitoring sys-

tem; and a compact standalone ultrasound imaging unit connected to the patient monitoring system continuously collecting ultrasound images from a patient and processing the ultrasound images to continuously extract therefrom diagnostic data.

[0007] The present invention is also achieved by a method including: integrating an ultrasound imaging unit to a patient monitoring system; connecting the ultrasound imaging unit to a patient; continuously collecting ultrasound imaging data from the patient; processing the ultrasound imaging data to generate therefrom diagnostic data; continuously transmitting the diagnostic data using a communication channel to a person or to a remote diagnostic system at another location; and analyzing the diagnostic data and determining therefrom a medical treatment for the patient.

[0008] These together with other objects and advantages, which will be subsequently apparent, reside in the details of construction and operation as more fully hereinafter described and claimed, reference being had to the accompanying drawings forming a part hereof, wherein like numerals refer to like parts throughout.

BRIEF DESCRIPTION OF THE DRAWINGS

[0009] Advantages of the invention will become apparent and more readily appreciated for the following description of the preferred embodiments, taken in conjunction with the accompanying drawings of which:

[0010] **FIG. 1** is a schematic diagram of an embodiment of a system including an ultrasound imaging unit as a plug-in module in accordance with the present invention; and

[0011] **FIG. 2** is a schematic diagram of an embodiment of a standalone ultrasound imaging unit in accordance with the present invention;

[0012] **FIG. 3A** is a display unit showing a split screen display;

[0013] **FIG. 3B** is a display unit showing a "window-in-window" display; and

[0014] **FIG. 4** is a flow chart illustrating a method embodiment of the present invention.

DETAILED DESCRIPTION OF THE INVENTION

[0015] Reference will be now made in detail to the present exemplary embodiments of the present invention, examples of which are illustrated in the accompanying drawings, wherein like reference numerals refer to the like elements throughout.

[0016] Patient monitoring functions are routinely performed on a variety of patients in many different settings of clinical usage, for instance intensive care units, surgical recovery units, individual patient monitoring, etc. Parameters obtained from the patient monitoring functions typically include cardiac functions (i.e., EKG, blood pressure, etc.), temperature, respiration, fetal activity, etc. These parameters are taken in a continuous period of time. In contrast, an ultrasound imaging exam for diagnostic image acquisition is typically conducted at sporadic times. Nevertheless, ultrasound imaging offers a potentially valuable adjunct to the parameters measured during patient monitor-

ing applications, which require continuous periods of monitoring. The parameters that may be extracted from an ultrasound image, such as stroke volume would be useful when monitoring the cardiac condition in the patient.

[0017] For instance, in a recovery situation if medication is provided to the patient to correct for wall motion abnormalities in the heart, it is necessary to determine if the medication was effective. Ultrasound imaging may be used to monitor whether the medication is effective in the patient. However, determining whether the medication was effective requires that the heart be monitored for a continuous period of time. Thus, an ultrasound imaging enhancement unit in accordance with the present invention, would execute an ultrasound imaging exam for a continuous period of time, necessary to monitor the effectiveness of medication.

[0018] A variety of algorithms could be applied to the ultrasound imaging unit as applied to patient monitoring applications. Such applications enable much more autonomous operation of the ultrasound imaging unit than conventional diagnostic imaging situations, which require a sonographer to be present full time with the patient.

[0019] The ultrasound imaging unit may implement a conventional automatic gain control to optimize the image gain, contrast, etc. The automatic gain control would be useful in initial setup of the ultrasound imaging unit to acquire an ultrasound image with minimal manual intervention, to maintain the image quality overtime, and to compensate for patient motion.

[0020] Conventional algorithms that may be modified and implemented into the ultrasound imaging unit to continuously extract from the ultrasound image patient monitoring parameters are, for instance, an automatic boundary extraction algorithm and regional wall motion algorithm. The automatic boundary extraction algorithm delineates boundaries of cardiac chambers, allowing derivation a several clinically useful measurements for cardiac monitoring applications. Conventional integrated backscatter methods could be employed for such boundary recognition. Further, kinesis measurements of tissue motion may be employed in the ultrasound imaging unit to continuously obtain contractility measurements, utilizing Doppler techniques, or others. As previously set forth, current ultrasound monitoring systems execute the algorithms in a non-continuous manner. The ultrasound imaging unit of the present invention modifies these algorithms by executing the algorithms in a continuous manner. Accordingly, the present invention provides for an ultrasound imaging unit allowing a physician to continuously extract from ultrasound images physiological data from a patient. This data, collected continuously over a period of hours or days, would allow generation of long-term trend analysis of physiological functions. Such trend data could be correlated against interventional measures to provide feedback information on the intervention's efficacy. Such ultrasound based feedback is very difficult to obtain from the present intermittent imaging methodologies.

[0021] In current ultrasound systems, once the user connects the ultrasound system to the patient or a TEE probe is inserted into the patient, the user places cursors or markers on the image of the heart to define what specific region of the heart the algorithm should be confined to analyze. Once the user determines the particular region of the heart that must be monitored, the user then selects a particular algorithm to

be executed. During execution, the algorithm extracts required information and outputs a numeric number or a short-term waveform of the response of the heart versus time on a heartbeat by heart beat basis.

[0022] In contrast, the ultrasound imaging unit of the present invention would require less user intervention and less user sophistication. Specifically, once the user connects the ultrasound imaging unit to the patient or the TEE probe is inserted into the patient, the ultrasound imaging unit could automatically analyze and determine the region of the heart that needs to be monitored. In a display unit, the user would be able to see the window or region determined by the algorithm in the ultrasound imaging unit that requires attention. The ultrasound imaging unit may incorporate alarms indicating to the user whether the patient's cardiac functions, such as stroke volume, contractility, etc. have exceeded a predetermined threshold. Accordingly, the ultrasound imaging unit would continuously acquire patient monitoring information and present the information as trend data rather than instantaneous data.

[0023] The ultrasound imaging unit may be connected to a hospital network for remote monitoring. The ultrasound imaging unit may include a communication channel to download to the hospital network patient monitoring information. Thus, control of the ultrasound imaging unit may be autonomous, contained as "smart" control algorithms in the ultrasound imaging unit, or remotely controlled from a central station in the hospital. Further, the ultrasound imaging unit of the present invention may provide a remote override capability where if a physician at a remote location does not like the information provided from the ultrasound imaging unit, the physician may manually override and control the ultrasound imaging unit remotely. Thus, the ultrasound imaging unit of the present invention is flexible where a physician may monitor multiple patients from the central station and remotely control the patient monitoring unit to continuously optimize an ultrasound image and thereby obtain optimized physiological information from each patient.

[0024] The information downloaded via the communication network may include basic images, monitoring information derived from the images, or other ultrasound information. The ultrasound imaging unit may itself derive the monitoring information, or the ultrasound images would be directly downloaded to the central station and processed by a remote information processor at the central station to derive therefrom the monitoring information.

[0025] FIG. 1 is a schematic diagram of an embodiment of a system including an ultrasound imaging unit as a plug-in module 10, which is plugged into a bedside patient monitor unit 20. A cable 25 is connected from the ultrasound plug-in module 10 to a probe, such as a TEE probe 30 or an endoscope in the patient to monitor cardiac activity. The TEE probe 30 may be remotely manipulated or monitored from a central station via the communication channel in the ultrasound plug-in module 10 or may be manipulated from the bedside patient monitor unit 20 to obtain different views and direct the transducer in the TEE probe 30 to a particular region of the heart to obtain an optimal view of the heart. The communication channel may include a communication cable, an infrared (IR) port, a telephone modem, a wireless modem, or a business intranet connection. Thus, the output

from the patient monitor unit **20** may be connected to a communication network of the central location, such as a clinical institution to allow immediate access to information derived from the ultrasound images for patient monitoring activities.

[0026] The patient monitor unit **20** is a modular device including a display **35**, which the physician monitors at the bedside. Multiple small modules **40** are provided that plug into various slots within the patient monitor unit **20**. For instance, if it is necessary to monitor a patient's ECG, then an ECG module **50** is plugged into the patient monitor unit **20**. A cable **60** is connected from the ECG module **50** to electrodes on the patient. Similarly, if the physician is monitoring blood pressure, a blood pressure module **70** is plugged into the patient monitor unit **20** and a cable **80** is connected from the blood pressure module **70** to a pressure transducer (not shown) on the patient. In this instance, the algorithms extracting the patient information from the ultrasound images may be stored and executed by the ultrasound plug-in module **10**, by the patient monitor unit **20**, or by a remote processor at the remote location. The algorithms would generate the ultrasound displays and may process pressure waveforms, cardiac waveforms, and ultrasound waveforms in a continuous manner. Further, the algorithms would process the image information to provide patient monitoring information. The information received and/or processed at the patient monitor unit **20** may be downloaded to the remote processor at the central station and displayed for observation at that station.

[0027] Information gained from the ultrasound imaging unit may be used to generate trend line data for analysis by clinical staff. It could also be integrated with other clinical data obtained from other algorithms that may be implemented into the patient monitoring system. For example, combining stroke volume with pressure data could prove useful in analysis of cardiac workload capability.

[0028] An alarm may be triggered at the bedside and/or at the central station if the processor determines from the waveforms that the patient's diagnostics exceed predetermined thresholds. A physician at the central station may send a feedback signal via the network to the patient monitor unit **20** to manipulate the ultrasound image to optimize the image, to manipulate the TEE probe **30**, or to command further testing.

[0029] FIG. 2 is a schematic diagram of an embodiment of a standalone ultrasound imaging unit **90**. The standalone ultrasound imaging unit **90** is connected to the patient monitor unit **20**. The control, operation, and exchange of patient information between the patient monitor unit **20**, the ultrasound imaging unit **90**, and the central station are described in FIG. 1.

[0030] The patient monitor unit **20** and the ultrasound imaging unit **90** each may independently or concurrently download patient monitoring information to the central station. The ultrasound imaging unit **90** may process the ultrasound images obtained to generate patient monitoring information or may download the images to the patient monitor unit **20** or the central station for processing. A cable **96** is connected from the ultrasound imaging unit **90** to a trans-nasal TEE probe, entering the patient through a nasal passage, residing in the esophagus.

[0031] FIG. 2, the ultrasound imaging unit **90** is illustrated as a dedicated display unit. A separate display unit **92** on the

patient monitor unit **20** displays waveforms from the ECG module **50** and the blood pressure module **70**. The patient monitor display unit **92** may be used to also display ultrasound derived images or data. The ultrasound imaging unit **90** may include sophisticated image demodulation techniques, such as acoustic quantification or color kinesis or regional wall motion, which is an algorithm to determine abnormal heart wall motions. These sophisticated image demodulation techniques could be applied to the ultrasound image information by either local processing, or remote processing capability.

[0032] Either ultrasound imaging unit shown in FIGS. 1 and 2 may be incorporated in an ambulatory vehicle, where a user would not be required to have expertise in monitoring cardiac activity, for instance. The user would download the images via an RF connection, for instance, to a hospital network where the physician would be able to read the images and to obtain therefrom continuous diagnostic data from the patient. The physician may then communicate with the user of the system recommending treatment or medication to the patient while continuously monitoring the patient's condition. In the alternative, the physician may remotely control the ultrasound imaging unit.

[0033] FIG. 3A is a schematic diagram of a split screen display displaying the patient's physiological parameters including ECG and blood pressure, and related trend lines on one side of the screen. The ultrasound image and related trend lines extracted from the ultrasound image are shown on the other side of the screen. FIG. 3B is a schematic diagram of a display unit showing a "window-in-window" display. Here, the ultrasound image and related trend lines extracted from the ultrasound image are shown as a smaller window within the main patient monitoring window. ECG, blood pressure, and related trend lines are also displayed on the same display.

[0034] As illustrated in FIG. 4, a flow chart illustrating a method embodiment of the present invention is shown. At operation **100**, the user of the ultrasound imaging unit **10, 90** inserts the TEE probe **30** into the patient. At operation **110**, the ultrasound imaging unit **10, 90** continuously collects ultrasound image data. At operation **120**, the ultrasound imaging unit **10, 90**, the patient monitor unit **20**, or a remote processing station, such as the central station, continuously processes the ultrasound image data collected to diagnostic data. At operation **130**, the ultrasound imaging unit **10, 90** or the patient monitor unit **20** continuously transmits the diagnostic data to the physician at another location to analyze the diagnostic data. At operation **140**, if the diagnostic data is adequate to determine a medical treatment for the patient, then, at operation **150**, the physician recommends the medical treatment for the patient to the user. Otherwise, from operation **140**, the method returns to operation **110** where the procedure is repeated to continuously obtain the diagnostic data.

[0035] Accordingly, the present system provides for an ultrasound imaging unit, integrated into a patient monitoring system to generate continuously and in real-time physiological information from an ultrasound image. Further, the ultrasound imaging unit, according to the present invention, provides flexibility to a user by allowing a physician to monitor multiple patients from a central location and remotely control the patient monitoring unit including the

ultrasound imaging unit. The system would be able to automatically regulate and control the ultrasound-monitoring module to generate an optimal ultrasound image.

[0036] Although a few preferred embodiments of the present invention have been shown and described, it would be appreciated by those skilled in the art that changes may be made in this embodiment without departing from the principles and spirit of the invention, the scope of which is defined in the claims and their equivalents.

What is claimed is:

1. An apparatus, comprising:
a patient monitoring system; and
an ultrasound imaging unit integrated into the patient monitoring system continuously generating ultrasound images from a patient and continuously extracting therefrom diagnostic data.
2. The apparatus as recited in claim 1, wherein the ultrasound imaging unit is a plug-in unit.
3. The apparatus as recited in claims 1, wherein the ultrasound imaging unit continuously executes at least one of an automatic boundary extraction algorithm, regional wall motion algorithm, an automatic gain control algorithm, kinesis measurement, or a physiological measurement.
4. The apparatus as recited in claims 1, wherein the ultrasound imaging unit continuously transmits the diagnostic data using a communication channel integrated therein to a person at a remote location.
5. The apparatus as recited in claim 4, wherein the person at the remote location remotely controls the continuous extraction of the diagnostic data from the ultrasound images.
6. The apparatus as recited in claims 1, wherein the ultrasound imaging unit is coupled to a probe insertable through a mouth or a nose of the patient to monitor the region for a continuous period of time.
7. The apparatus as recited in claim 6, wherein the person at the remote location remotely manipulates the probe via a communication channel in the ultrasound imaging unit.
8. The apparatus as recited in claims 1, wherein the ultrasound imaging unit automatically determines a region of a heart of the patient that needs to be monitored.
9. The apparatus as recited in claim 8, wherein the ultrasound imaging unit further comprises a remote override capability allowing a person at a remote location to override and manually determine the region of the heart of the patient that needs to be monitored.
10. The apparatus as recited in claims 1, wherein the patient monitoring system comprises slots to plug modules comprising at least one of a blood pressure module and an ECG module to monitor a patient's blood pressure and ECG signals.
11. The apparatus as recited in claims 10, wherein the ultrasound imaging unit comprises a communication channel to download to a hospital network at least one of the ultrasound images, the diagnostic data, the blood pressure, and the ECG signals.
12. The apparatus as recited in claims 1, further comprising a display screen displaying the ultrasound images and the diagnostic data on a screen.
13. The apparatus as recited in claim 12, further comprising a split screen display displaying patient monitoring data and related trend lines and the ultrasound images and related trend lines extracted from the ultrasound images.

14. The apparatus as recited in claim 12, further comprising a window-in-window display displaying patient monitoring data and related trend lines together with the ultrasound images and related trend lines extracted from the ultrasound images.

15. The apparatus as recited in claims 1, wherein the apparatus comprises an alarm indicating that a patient's physiological parameter has exceeded a predetermined threshold, where the alarm is triggered by the ultrasound images or the diagnostic data comprising stroke volume, heart rate, or blood pressure.

16. An apparatus, comprising:
a patient monitoring system; and
a compact standalone ultrasound imaging unit connected to the patient monitoring system continuously collecting ultrasound images from a patient and processing the ultrasound images to continuously extract therefrom diagnostic data.

17. The apparatus as recited in claims 16, wherein the ultrasound imaging unit continuously executes at least one of an automatic boundary extraction algorithm, regional wall motion algorithm, an automatic gain control algorithm, kinesis measurement, or a physiological measurement.

18. The apparatus as recited in claims 16, wherein the person at the remote location remotely controls via a communication channel the continuous extraction of the diagnostic data from the ultrasound images.

19. The apparatus as recited in claims 18, wherein the communication channel comprise a communication cable, an infrared (IR) port, a telephone modem, a wireless modem, or a business intranet connection.

20. The apparatus as recited in claim 16, wherein the ultrasound imaging unit automatically determines a region of a heart of the patient that needs to be monitored.

21. The apparatus as recited in claim 20, wherein the ultrasound imaging unit further comprises a remote override capability allowing a person at a remote location to override via a communication channel and manually determine the region of the heart of the patient that needs to be monitored.

22. The apparatus as recited in claim 16, wherein a person at a remote location remotely manipulates a probe coupled to the ultrasound imaging unit via a communication channel in the ultrasound imaging unit.

23. The apparatus as recited in claim 16, wherein the ultrasound imaging unit comprises a communication channel to download to a hospital network at least one of the ultrasound images and the diagnostic data.

24. The apparatus as recited in claims 16, further comprising a display screen displaying the ultrasound images and the diagnostic data on a screen.

25. The apparatus as recited in claim 24, further comprising a split screen display displaying patient monitoring data and related trend lines and the ultrasound images and related trend lines extracted from the ultrasound images.

26. The apparatus as recited in claim 24, further comprising a window-in-window display displaying patient monitoring data and related trend lines together with the ultrasound images and related trend lines extracted from the ultrasound images.

27. The apparatus as recited in claims 16, wherein the apparatus comprises an alarm indicating that a patient's physiological parameter has exceeded a predetermined

threshold, where the alarm is triggered by the ultrasound images or the diagnostic data comprising stroke volume, heart rate, or blood pressure.

28. A method comprising:

integrating an ultrasound imaging unit to a patient monitoring system;

connecting the ultrasound imaging unit to a patient; and continuously collecting ultrasound imaging data from the patient.

29. The method as recited in claim 28, further comprising:

processing the ultrasound imaging data to generate therefrom diagnostic data.

30. The method as recited in claim 29, further comprising:

continuously transmitting the diagnostic data using a communication channel to a person at another location.

31. The method as recited in claim 30, further comprising:

analyzing the diagnostic data and determining therefrom a medical treatment for the patient.

32. The method as recited in claim 28, further comprising:

continuously executing at least one of an automatic boundary extraction algorithm, regional wall motion algorithm, an automatic gain control algorithm, kinesis measurement, or a physiological measurement.

33. The method as recited in claim 28, further comprising:

automatically determining and analyzing a region of a heart of the patient that needs to be monitored using the ultrasound imaging unit.

34. The method as recited in claim 28, further comprising:

allowing a person to override and manually control the ultrasound imaging unit.

35. The method as recited in claim 29, further comprising:

continuously transmitting the ultrasound imaging data and the diagnostic data.

* * * * *

专利名称(译)	超声成像增强临床患者监测功能		
公开(公告)号	US20030163045A1	公开(公告)日	2003-08-28
申请号	US10/086007	申请日	2002-02-28
[标]申请(专利权)人(译)	皇家飞利浦电子股份有限公司		
申请(专利权)人(译)	皇家飞利浦电子N.V.		
当前申请(专利权)人(译)	皇家飞利浦电子N.V.		
[标]发明人	GATZKE RONALD D		
发明人	GATZKE, RONALD D.		
IPC分类号	A61B5/00 A61B5/0205 A61B5/0402 A61B8/08 A61B8/12 A61B8/14 A61B8/00		
CPC分类号	A61B5/00 A61B5/0002 A61B5/0205 A61B5/0402 A61B8/08 A61B8/582 A61B8/14 A61B8/463 A61B8/56 A61B8/565 A61B8/12		
其他公开文献	US6705992		
外部链接	Espacenet USPTO		

摘要(译)

一种装置包括集成到患者监测系统之中的超声成像单元，其连续地从患者生成超声图像并连续地从中提取诊断数据。

