

(19) World Intellectual Property Organization
International Bureau



(43) International Publication Date
31 January 2002 (31.01.2002)

PCT

(10) International Publication Number
WO 02/07601 A2

- (51) International Patent Classification⁷: **A61B 8/00**
- (21) International Application Number: PCT/GB01/03262
- (22) International Filing Date: 20 July 2001 (20.07.2001)
- (25) Filing Language: English
- (26) Publication Language: English
- (30) Priority Data:
0017674.3 20 July 2000 (20.07.2000) GB
- (71) Applicant (for all designated States except US): **JOMED IMAGING LIMITED** [GB/GB]; 3A Centaurs Business Park, Grant Way, Isleworth, Middlesex TW7 5QD (GB).
- (72) Inventors; and
- (75) Inventors/Applicants (for US only): **NIX, Elvin** [GB/GB]; 11612 Boom Pointer Way, Gold River, CA 95670 (GB). **HOWES, William** [GB/GB]; 117 Russell Road, Wimbledon, London SW19 1LN (GB). **DICKINSON, Robert** [GB/GB]; 51 West Hill Road, Wandsworth, London SW18 1LE (GB). **WNENDT, Stephan** [DE/DE]; Adenaver Allee 203, 52062 Aachen (DE).
- (74) Agent: **BURRINGTON, Alan, Graham, Headford**; Atkinson Burrington, 25-29 President Buildings, President Way, Sheffield S4 7UR (GB).
- (81) Designated States (national): AE, AG, AL, AM, AT, AU, AZ, BA, BB, BG, BR, BY, BZ, CA, CH, CN, CO, CR, CU, CZ, DE, DK, DM, DZ, EE, ES, FI, GB, GD, GE, GH, GM, HR, HU, ID, IL, IN, IS, JP, KE, KG, KP, KR, KZ, LC, LK, LR, LS, LT, LU, LV, MA, MD, MG, MK, MN, MW, MX, MZ, NO, NZ, PL, PT, RO, RU, SD, SE, SG, SI, SK, SL, TJ, TM, TR, TT, TZ, UA, UG, US, UZ, VN, YU, ZA, ZW.
- (84) Designated States (regional): ARIPO patent (GH, GM, KE, LS, MW, MZ, SD, SL, SZ, TZ, UG, ZW), Eurasian patent (AM, AZ, BY, KG, KZ, MD, RU, TJ, TM), European patent (AT, BE, CH, CY, DE, DK, ES, FI, FR, GB, GR, IE, IT, LU, MC, NL, PT, SE, TR), OAPI patent (BF, BJ, CF, CG, CI, CM, GA, GN, GQ, GW, ML, MR, NE, SN, TD, TG).

Declaration under Rule 4.17:
 — as to applicant's entitlement to apply for and be granted a patent (Rule 4.17(ii)) for the following designations AE, AG, AL, AM, AT, AU, AZ, BA, BB, BG, BR, BY, BZ, CA, CH,

[Continued on next page]

(54) Title: ULTRASONIC IMAGING CATHETERS

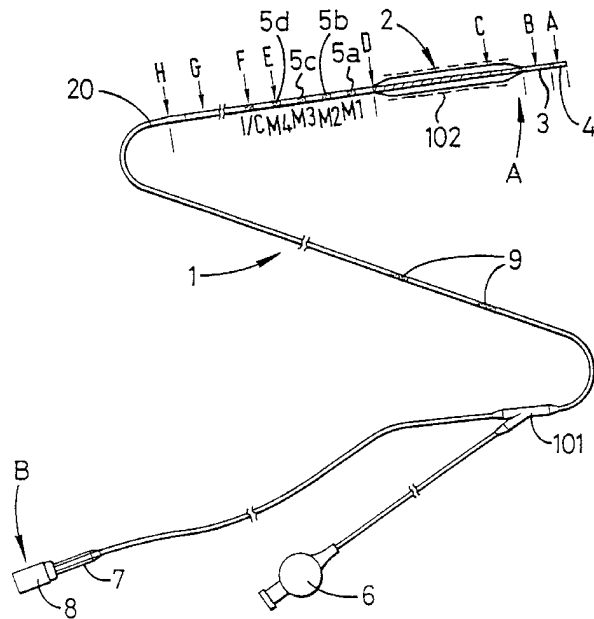

(57) Abstract: An intravascular ultrasonic imaging catheter is provided with a flexible circuit electrically coupled to a transducer array mounted on the distal end of the catheter, a portion of the flexible circuit being helically wound about the catheter in order to enhance the flexibility of the circuit. The catheter may be a balloon catheter which is also provided with a stent mounted on the balloon, the stent carrying one or more drugs designed to be eluted or washed into a patient's blood stream after the stent has been delivered, by a the balloon catheter, into a target area within the patient's vascular system.

WO 02/07601 A2



CN, CO, CR, CU, CZ, DE, DK, DM, DZ, EE, ES, FI, GB, GD, GE, GH, GM, HR, HU, ID, IL, IN, IS, JP, KE, KG, KP, KR, KZ, LC, LK, LR, LS, LT, LU, LV, MA, MD, MG, MK, MN, MW, MX, MZ, NO, NZ, PL, PT, RO, RU, SD, SE, SG, SI, SK, SL, TJ, TM, TR, TT, TZ, UA, UG, UZ, VN, YU, ZA, ZW, ARIPO patent (GH, GM, KE, LS, MW, MZ, SD, SL, SZ, TZ, UG, ZW), Eurasian patent (AM, AZ, BY, KG, KZ, MD, RU, TJ, TM), European patent (AT, BE, CH, CY, DE, DK, ES, FI, FR, GB, GR, IE, IT, LU, MC, NL, PT, SE, TR), OAPI patent (BF, BJ, CF, CG, CI, CM, GA, GN, GQ, GW, ML, MR, NE, SN, TD, TG)

Published:

— without international search report and to be republished upon receipt of that report

For two-letter codes and other abbreviations, refer to the "Guidance Notes on Codes and Abbreviations" appearing at the beginning of each regular issue of the PCT Gazette.

Ultrasonic Imaging Catheters

This invention relates to ultrasonic imaging catheters including catheters which are combined with a balloon device.

5 Catheters having an ultrasonic transducer array mounted on the distal end of the catheter are known. Examples are the arrangement disclosed in the present applicant's United Kingdom patent numbers: 2 208 138; 2 212 267; 2 233 094 and 2 246 632.

10 Catheters fitted with a balloon which can be distended in order to press plaque in a patient's artery back into the wall of the artery (a procedure known as angioplasty) in order to increase the cross section of the artery's lumen are also well known.

15 In the applicant's published United Kingdom patent No. 2 325 020 there is disclosed a catheter which has the combination of an ultrasonic array at or near its distal end combined with a balloon arrangement also carried at or near the distal end of the catheter. With the arrangement disclosed in the applicant's United Kingdom Patent No. 2 287 375 the ultrasonic imaging system includes a multiplexing arrangement which is also mounted on the catheter at or near its distal end. This specification also discloses a method
20 of manufacturing the transducer/multiplexer arrangement which method involves first manufacturing the arrangement in a flat configuration and then wrapping it into a cylindrical circular cross-section configuration. The transducer array and multiplexer arrangement are linearly separated from one another but electrically inter-connected by what will be referred to as a
25 flex circuit. The transducer array is cylindrical in its final configuration as is the multiplexer arrangement, the latter consisting typically of four multiplexer

units, arranged in a cylindrical box section.

The catheters to which the present invention relates are typically around one millimetre in external diameter. In the case where the catheter also incorporates an angioplast balloon and this balloon, when inflated, might typically have an external diameter of three millimetres.

There is a requirement to be able to provide the ultrasonic imaging arrangement previously described either alone or in combination with a balloon arrangement previously described in a catheter having a smaller outside diameter. More specifically, in this art the diameter of catheters is expressed in terms of units known as "french" and the present invention is concerned with providing a combined ultrasonic imaging system/balloon catheter arrangement suitable for use with a 2.4 - 2.9 french combination catheter. (1 French equals 0.013 inches)

There is a requirement that a stent can be pre-mounted onto the balloon and firmly attached so it does not detach.

There is a requirement that the combination catheter should smoothly negotiate a six french guide catheter and a blood vessel with a seven millimetre bend radius and it should do so without damage to the electrical circuitry and components associated with the transducer.

The following requirements/constraints apply when designing a catheter having an ultrasonic transducer array, an associated multiplexer arrangement, a balloon and a stent inserted on the balloon:

- a) the balloon needs to be close to the ultrasonic array at the catheter's distal end from a visualisation point of view;
- b) the multiplexer needs to be close to the ultrasonic array in order to minimise the length of the electrical connections between them and to enhance the rigidity of the distal tip of the catheter;

- c) locating the multiplexer within the balloon to meet the requirement of
b) means that it needs to be electrically insulated from the saline
solution used to inflate the balloon;
- d) the stent needs to be securely mounted on the outside of the balloon
5 so that it cannot be dislodged and can be radially expanded by
inflation of the balloon;
- e) one way to secure the stent on the outside of the balloon is to crimp it
in position;
- f) crimping the stent around the balloon can cause damage to the
10 balloon and anything contained within it.

The present invention is concerned with designing the catheter in such
a way that these conflicting design requirements are substantially met.

According to a first aspect of the present invention a catheter balloon
specified in the first aspect above is characterised in that the multiplexer units
15 are longitudinally separated from the transducer, and a balloon device is
positioned between the most distal multiplexer and the transducer.

According to a second aspect of the present invention a catheter
having an ultrasonic transducer including a plurality of multiplexer units is
characterised in that the multiplexer units are longitudinally separated from
20 one another along the length of the catheter. The catheter may also include
a balloon device.

According to a third aspect of the present invention a catheter has an
ultrasonic transducer arrangement located at or near its distal end, which
arrangement includes a flexible circuit through which electrical power can be
25 supplied to the transducer array, characterised in that the flexible circuit
incorporates at least one helically wound section so constructed as to
enhance the flexibility of that circuit and its ability to accommodate bending

as the catheter is moved along a non-linear path such as an artery of a patient. The catheter may also include a balloon device.

According to a fourth aspect of the present invention the catheter arrangement specified in the first aspect above is characterised in that there are flex circuits between adjacent longitudinally separated multiplexer units, those flex circuits being characterised in that they are helically wound in order to enhance their flexibility and the overall catheter assembly's capability of negotiating bends in a non-linear path without damage being caused as a result of the bending.

According to a fifth aspect of the present invention a catheter which includes an inflatable balloon device, an ultrasonic transducer array and a flexible electrical circuit adapted to supply current to the transducer array is characterised in that at least a portion of the flexible circuit is located within the balloon device and, in use, is directly exposed to the inflating fluid introduced into the balloon device, i.e. that portion of circuit is not enclosed in a protective tube but is insulated to function when immersed.

According to a sixth aspect of the present invention a stent is crimped over the balloon, such that the crimping force does not damage the multiplexer and transducer, and the helical flex circuit limits the minimum diameter the stent is crimped to.

How the invention may be carried out will now be described by way of example only and with reference to the accompanying drawings in which:

Figure 1 is a schematic representation of a combination catheter incorporating the present invention;

Figure 2 is a fragmentary view on a larger scale showing a balloon device, ultrasonic transducer array and associated multiplexer arrangement forming part of the overall arrangement shown in *Figure 1*;

Figure 3 is a side elevational fragmentary view on an enlarged scale illustrating a guide wire exit to a catheter having an inner and outer body at its distal end;

Figure 4 comprises five cross-sectional views, *Figures 4A, 4B, 4C, 4D* and *4E* taken on the lines A-A, B-B, C-C, D-D and E-E respectively of *Figures 1 and 3*.

Figure 5 is a sectional elevational view on an enlarged scale showing that portion of the catheter which comprises the transducer array adjacent the distal end of the balloon device, both balloon and transducer being located at or near the distal end of the catheter itself;

Figure 6 comprises *Figure 6A* which shows that part of the catheter which includes the transducer array, flex circuit and multiplexers when they are in the flat condition and *Figure 6B* which shows the same arrangement when they are in the wrapped condition; and

Figure 7 is an enlarged prospective view of a drug loaded stent according to the present invention.

Figure 1

This is a diagrammatic illustration of the overall catheter arrangement to which the present invention is applied.

The detailed construction is shown in the other figures of the drawings in which the same reference numerals have been used to designate the same or equivalent elements.

In *Figure 1* a catheter generally indicated at **1** has at its distal end **A** the combination of a balloon unit **2** and an ultrasonic annular transducer array **3**, the extreme distal end of the catheter comprising a soft tip **4**.

Associated with the transducer array **3** is a multiplexing arrangement indicated at **5**.

At the proximal end **B** of the catheter there is provided a balloon inflation port **6** by which fluid (typically a saline solution **19**) can be introduced through the catheter into the balloon **2** in order to inflate it in known manner.

Also at the proximal end **B** there is provided a connector **7** and associated strain relief device **8** by which the proximal end **B** of the catheter may be connected to a catheter interface module (CIM) and thus to the electronic imaging system.

At an intermediate point along its length the catheter is provided with opaque markers **9** to assist the clinician in being able to see the catheter within the patient's artery using x-ray equipment.

The ultrasonic transducer array **3** is provided with electrical power by means of a ribbon cable **22** which runs the length of the catheter, the proximal end of the ribbon cable being connected to an electrical supply and control arrangement (not shown) which itself is not part of the present invention.

The multiplexing arrangement **5** consists of a number of multiplexing units, in this case four, the functional purpose of which is to reduce the number of electrical leads which would otherwise have to be provided along the length of the catheter in order to energise the large number of transducer elements in the transducer array **3**. Typically the number of elements would be sixty four. By having a multiplexing arrangement the number of electrical leads can be significantly reduced. The provision of such a multiplexing arrangement is known.

The present invention is concerned with the configuration and construction of the multiplexing arrangement and the associated flexible

circuit and the relationship of the balloon device to the flexible circuit.

According to the present invention the individual multiplexing units **5a**, **5b**, **5c** and **5d** are longitudinally spaced from one another along the length of the catheter as indicated in *Figure 1*, the longitudinal spacing being identified as "S".

In the arrangement of *Figure 1* the longitudinally spaced multiplexing units **5** are located immediately proximal to the balloon device **2** which in turn is proximal to the ultrasonic transducer array **3**.

Mounted on the balloon is an optional stent **102** which is crimped onto the balloon. The helical flex circuit **12** acts as a limit to the crimping of the stent. The crimping operation involves application of a force which would otherwise damage components inside, but in this design the components are outside the stent region.

The construction of this distal end of the catheter is illustrated in more detail in *Figures 2 to 5*.

Figures 2 to 5

The ultrasonic transducer array **3** consists of sixty-four individual transducer elements arranged in a cylindrical configuration, these elements being contained between a proximal ring **24** and a distal ring **25** (*Figure 2*). The multiplexer units **5a**, **5b**, **5c** and **5d** are electrically connected to the transducer array **3** by means of a flexible circuit indicated at **12**.

This flexible circuit **12** is arranged in a helical configuration and it passes from the transducer array **3** to the multiplexer units **5** through the balloon device **2**.

The balloon device **2** comprises a flexible and expandable balloon envelope **13** which is sealed at **14** and **15** to the catheter.

That portion of the flexible circuit **12** which passes through the inside of the balloon unit **2** is insulated with a water proof coating such as Parylene™ (Speciality Coatings Ltd, Northampton) and exposed to the fluid (typically a saline solution **19**) which is used to inflate the balloon envelope **13**, i.e. that part of the flexible circuit **12** which is within the balloon envelope **13** is not contained within any protective tube.

At its distal end the catheter **1** consist of an inner body or tube **16** and an outer body or tube **17**.

The catheter is inserted into a patient's artery after a metal guide wire **18** (see *Figure 3*) has first been inserted into the artery. The catheter then in effect runs down the guide wire to bring the distal end of the catheter into the target area within the patient.

More specifically the catheter is loaded onto the proximal end of the guide wire **18** by the clinician who pushes the inner body **16** over the proximal end of the guide wire and then feeds the catheter down the guide wire. As this feeding operation occurs the guide wire **18** in effect passes outside the catheter at the guide wire exit indicated at **20**, in *Figure 3*, the guide wire exit **20** being formed by the end of the inner body **16**.

The proximal end of the outer body **17** is sealingly secured to an outer tube **1a** of the catheter which contains an inner tube **1b**, typically a stainless steel hypodermic, the tubes **1a** and **1b** running the length of the catheter **1** up to a Y-connector **101**.

A tapered metal member or wire known as a stilet **21** extends from the distal end of the inner tube **1b** into the space between the inner and outer bodies **16** and as illustrated in *Figure 3*. The purpose of the stilet **21** is to provide a support for the guide wire exit port which would otherwise have a tendency to kink.

Figure 4

This figure comprises figures **4A**, **4B**, **4C**, **4D** and **4E** which are cross-sections taken on the lines **G3**, **G2**, **G1**, respectively in *Figure 3*, and **F** and **E** respectively in *Figure 1*.

As can be seen from these cross-sections the ribbon cable **22** consists of a number of electrical leads which for most of its length are moulded together to form the unit shown in *Figures 4A, 4B and 4C*. However, at the point where it is required to connect electrically the various constituents of the ribbon cable to the four multiplexer units **5** the ribbon cable **22** is split into discreet leads as shown in *Figure 4D*. These leads are then connected to the respective multiplexer units via tracks on the flex circuit.

The manner in which each multiplexer unit is mounted is shown in *Figure 4E*. Each multiplexer unit is secured to the inner body **16** by means of adhesive **23**.

Figure 5

This shows on a greater scale and in more detail the extreme distal end of the catheter, the same reference numerals being used to designate parts already described with reference to earlier figures.

The annular ultrasonic transducer array **3** is contained between a proximal ceramic ring **24** and a stainless steel or ceramic distal ring **25**. At the distal end of the distal forming ring **25** there is the soft tip **4**, which is typically made from Nylon (RTM) which is heat melted or fused onto the distal end of the inner body **16**.

Figure 6

Figure 6A shows that part of the catheter which includes the transducer array **3** and multiplexers **5** when they are in the flat condition at an intermediate point in the manufacturing process. A more detailed disclosure
5 of the method of manufacturing this arrangement, which involves first constructing the transducer and multiplexer assembly in the flat and then converting it into a tubular configuration is disclosed in more detail in our United Kingdom Patent No. 2 297 375

Figure 6B shows the same arrangement as *Figure 6A* but after it has
10 been formed into the cylindrical configuration referred to earlier.

Figure 7

The present invention also envisages a stent, such as that shown at
102 in *Figure 1*, being loaded with one or more of a variety of drugs so that
15 the drug or drugs is/are eluted or washed from the stent by the patient's blood flowing past the stent.

By having a drug loaded stent mounted on an intravascular ultrasonic imaging catheter (IVUS) it is possible for the clinician to more accurately position the stent and target the drug where it is required in order to prevent,
20 for example, restenosis. The usual method of introducing a drug or drugs has been to simply introduce them generally into the patient's blood stream. However, this means that a large proportion of the introduced drug is in effect wasted and is not operative in the target area.

The loading of the drug or drugs onto the stent can be achieved in a
25 number of ways.

A drug loaded surface of a stent can be achieved by using different technological approaches. Each of these approaches can be conducted in a

way that the drug compound is released from the surface either in a short (hours) or an extended time frame (days). The release kinetics can be adjusted by applying specific modifications to the surface of the stent e.g. hydrophobic or hydrophilic side chains of a polymer carrier or a ceramic surface.

The following outlines four possible ways of loading the drug/drugs onto the stent.

1. Ceramic coating

An AlO_2 coating (patent applications DE 19855421, DE 19910188, WO 00/25841) with porous surface can be loaded with a drug in amounts between 250 μg and 10 mg by either dipping, spraying or similar techniques. The drug dose is dependent on the nature of the target vessel and the condition of the patient and is chosen such that cell proliferation is sufficiently inhibited, while healing is not hampered. The drug can be used as an aqueous or organic solution, e.g. in DMSO, DMF and methanol. After spraying or dipping (under mild vacuum) the treated stent is dried, the procedure is repeated three to ten times. After the final drying the stent is rinsed for one minute in water or isotonic saline at room temperature and then dried again. Drug content can be analysed by standard methods (HPLC, LC-MS) after eluting or washing the compound with a suitable solvent. Release kinetics can be analysed using a standard release apparatus.

2. ePTFE membrane: Stent Graft

Identical approach as above. The drug is absorbed into the cavities of the porous ePTFE membrane.

3. Polymeric coating in general

Different polymers are suitable for drug loading: methacrylate-polymers, polyurethane-coatings, ePTFE-coatings. The drug can be either applied to the final surface (see above) or directly added to the polymerisation solution.

4. Mechanical approach (Figure 7)

The mechanical approach is based on holes **701** that have been introduced into the stent **700** struts **702** using a laser. These holes can then be filled with a drug or drugs. The hole-approach can be combined with a thin, biodegradable coating that in itself is drug loaded. After initial release from the biodegradable coating the drug-filled holes can serve for long term release of active drug. Interstices for containing the drug may be formed in other ways than by holes.

A variety of drugs that could be loaded onto the stent are listed in the following three tables, Table A, Table B and Table C. It is intended that the listed drugs should also include their derivatives.

In this example the drugs are selected to be active in three phases, Table A being Phase I, Table B being Phase II and Table C being Phase III.

Phase I is aimed at effecting vasodilation e.g. the dilation of the patient's artery. The effects are listed in the table.

Phase II is aimed at inhibiting inflammation, etc as listed at the top of Table B. Again the effects of the drugs are set out in the table.

Phase III is aimed at the inhibition of cell proliferation and again the effects of the drugs are set out in the table.

TABLE A

Phase I - Vasodilation		
Drugs to be released with the first 24-72 h after stenting		
Drug name	Rationale/Effects	Priority
Molsidomine, linsidomine, sodium nitroprusside, nitroglycerol, NO-donors in general	Release of NO leads to vasodilation, reducing the degree of procedural vessel wall damage, stimulates the growth of endothelial cells, inhibits migration and proliferation of smooth muscle cells.	1
Stimulators of the soluble guanylate cyclase like BAY 41-2272 (5- (Cyclopropyl-2-[1-(2-fluoro-benzyl)-1H-pyrazolo[3,4-n]pyridin-3-yl]-pyrimidin-4-ylamine).	SGC stimulators induce vasodilation and other NO-effects by directly activating the target enzyme of NO.	1
Hydralazine.	Causes smooth muscle cell relaxation.	2
Verapamil, diltiazem, nifedipine, nimodipine and other Ca ²⁺ - channel blockers.	Smooth muscle cell contraction reduced by reducing intracellular Ca ²⁺ - concentrations.	3
Captopril, enalapril, lisinopril, quinapril and other angiotensin converting enzyme inhibitors.	Reduction of the angiotensin II level leads to reduced vasoconstriction.	1
Losartan, candesartan, irbesartan, valsartan and other angiotensin II receptor antagonists.	Reduced vasoconstriction is achieved by blocking the effect of angiotensin II at its target receptor located in the vascular tissue.	1

TABLE B

Phase II - Inhibition of inflammation, immunosuppression, promotion of endothelial cell growth, inhibition of cell migration.		
Drugs to be released within the first 2-21 days after stenting.		
Drug name	Rationale/Effects	Priority
Dexamethasone, Betamethasone, prednisone and other corticosteroids	Inhibition of inflammatory reactions by different effects on macrophages and monocytes, endothelial cells, basophils, fibroblasts and lymphocytes.	1
17-beta-estradiol	Inhibition of migration and proliferation of smooth muscle cells.	
FK506 (Tacrolimus)	Inhibition of T-cell response, reduction of pro-inflammatory cytokine release, inhibition of smooth muscle cell proliferation	1
Cyclosporine	Inhibition of T-cell response	3
Mycophenolic acid	Inhibition of B-cell response, inhibition of smooth muscle cell proliferation	3
VEGF, VEGF-receptor activators	VEGF is a growth factor stimulating the growth of smooth muscle cells	1
Tranilast	Has shown efficacy (prevention of restenosis) in animal trials after systemic applications, inhibits keloid scarring.	2
Mefoxicam, cefebrex, vioxx and other COX-2 antagonists	Antiinflammatory effect through inhibition of cyclooxygenase 2	2
Indomethacin, diclofenac, ibuprofen, naproxen and other COX-1 inhibitors	Antiinflammatory effect through inhibition of cyclooxygenase1, in addition platelet inhibition	3

Plasminogen activator inhibitor-1 and other serpins	Inhibits activation of prourokinase. Prourokinase promotes cellular migration by activating plasmin and metalloproteinases as well as other proteinases	1
Thrombin inhibitors as hirudin, hirulog, agratroban, PPACK etc.	Thrombin promotes thrombus formation but is also a strong mitogen (growth factor)	2
Interleukin-10	Antiinflammatory cytokine that inhibits monocytes	3

TABLE C

Phase III - Inhibition of cell proliferation		
Drugs to be released within the first 14 days to 3 months after stenting		
Drug name	Rationale/Effects	Priority
Sirolimus, SDZ RAD (40-O-(2-hydroxyethyl)-rapamycin and other rapamycin derivatives	Inhibition of T-cell response, reduction of pro-inflammatory cytokine release, inhibition of smooth muscle cell proliferation	1
PDGF-antagonists	Inhibition of smooth muscle cell proliferation and migration through inhibition of PDGF-signal transduction. PDGF is a strong mitogen for smooth muscle cells.	1
Paclitaxel	Inhibition of smooth muscle cell proliferation through promotion of microtubuli association	1

Cisplatin	Inhibition of smooth muscle cell proliferation through intercalation in DNA-double strand	2
Vinblastin	Inhibition of smooth muscle cell proliferation through inhibition of mitotic spindle formation	2
Mitoxantrone	Inhibition of smooth muscle cell proliferation through inhibition of DNA and RNA synthesis and inhibition of topoisomerase II 1	
Combretastatin A4	Inhibition of smooth muscle cell proliferation through inhibition of mitotic spindle formation	1
Topotecan	Inhibition of smooth muscle cell proliferation through inhibition of topoisomerase I	2
Methotrexate	Inhibition of smooth muscle cell proliferation through inhibition of dihydrofolate reductase	3
Flavopiridol	Inhibition of smooth muscle cell proliferation through inhibition of cell cycle kinase	1

Claims

1. Apparatus for ultrasonic imaging, the apparatus comprising:
a catheter having a distal region;
an ultrasonic transducer array disposed at the distal region; and
5 a flexible circuit electrically coupled to the transducer array for
supplying electrical power to the array,
wherein at least a portion of the flexible circuit is helically wound about
the catheter.
- 10 2. The apparatus of claim 1, wherein the portion of the flexible
circuit that is helically wound about the catheter is adapted to enhance
flexibility of the circuit as the catheter is moved along a non-linear path.
- 15 3. The apparatus of claim 1, wherein the portion of the flexible
circuit that is helically wound about the catheter is adapted to accommodate
bending the circuit as the catheter is moved along a non-linear path.
4. The apparatus of claim 1, wherein the flexible circuit is
insulated.
- 20 5. The apparatus of claim 1, wherein the apparatus has a
maximum external diameter of less than about 3 Fr.
- 25 6. The apparatus of claim 1, wherein the apparatus is adapted for
disposal within guiding catheters as small as 6 Fr.

7. The apparatus of claim 1, further comprising an imaging system coupled to the catheter.

5 8. The apparatus of claim 1, further comprising a plurality of multiplexer units electrically coupled to the flexible circuit proximal of the transducer array.

10 9. The apparatus of claim 8, wherein the helically wound portion of the flexible circuit is helically wound about the catheter between the ultrasonic transducer array and the multiplexer units.

15 10. The apparatus of claim 8, wherein the multiplexer units are longitudinally spaced with respect to one another along the length of the catheter.

11. The apparatus of claim 10, wherein the flexible circuit is helically wound about the catheter between the multiplexer units.

20 12. The apparatus of claim 1, further comprises an expandable balloon coupled to the catheter.

13. The apparatus of claim 12, wherein the balloon is coupled to the catheter proximal of the transducer array.

25 14. The apparatus of claim 13, further comprising a plurality of multiplexer units electrically coupled to the flexible circuit proximal of the balloon.

15. The apparatus of claim 14, wherein the helically wound portion of the flexible circuit is wound about the catheter between the ultrasonic transducer array and the multiplexer units.

5

16. The apparatus of claim 12, further comprising a stent coaxially disposed about the balloon.

10

17. The apparatus of claim 16, wherein the stent is crimped onto the balloon.

15

18. The apparatus of claim 17, wherein the helically wound portion of the flexible circuit is adapted to limit a minimum diameter to which the stent may be crimped.

19. The apparatus of claim 12, wherein a portion of the flexible circuit is disposed within the balloon.

20

20. The apparatus of claim 19, wherein the helically wound portion of the flexible circuit is disposed within the balloon.

21. The apparatus of claim 19, wherein the portion of the flexible circuit disposed within the balloon is adapted for exposure to inflation medium introduced into the balloon.

25

22. The apparatus of claim 19, wherein the portion of the flexible circuit disposed within the balloon is insulated.

5 **23.** A catheter which includes a balloon and a stent, the stent being pre-mounted on the balloon and the stent carrying a drug which is adapted to be eluted or washed from a stent into a patient's blood stream when the stent has been deposited at a target location within the patient.

24. A catheter as claimed in claim **23** in which the drug is applied to the stent as a coating.

10 **25.** A catheter as claimed in claim **23** in which the drug is lodged in interstices formed in the stent.

26. A catheter as claimed in any one of claims **23** to **25** in which the stent carries a drug which has characteristics to effect vasodilation.

15

27. A catheter as claimed in any one of claims **23** to **26** in which the stent carries a second drug to effect inhibition of inflammation, immunosuppression, promotion of endothelial cell growth and inhibition of cell migration.

20

28. A catheter as claimed in any one of claims **23** to **27** in which a stent carries a third drug to effect the inhibition of cell proliferation.

25 **29.** A method of manufacturing a catheter as claimed in any previous claim in which the transducer array and multiplexer arrangement are first manufactured in a flat configuration and then formed into a cylindrical configuration.

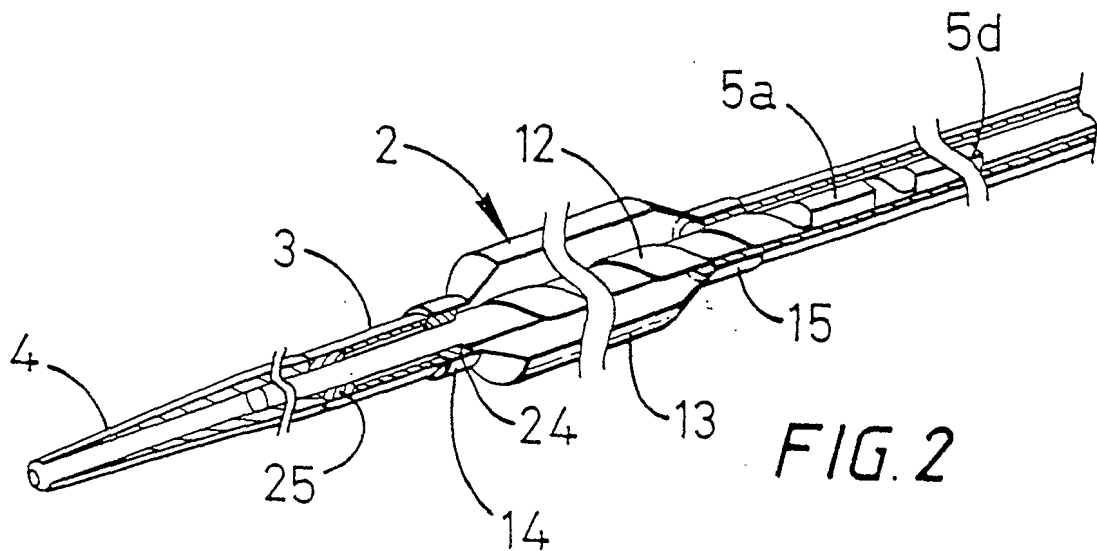
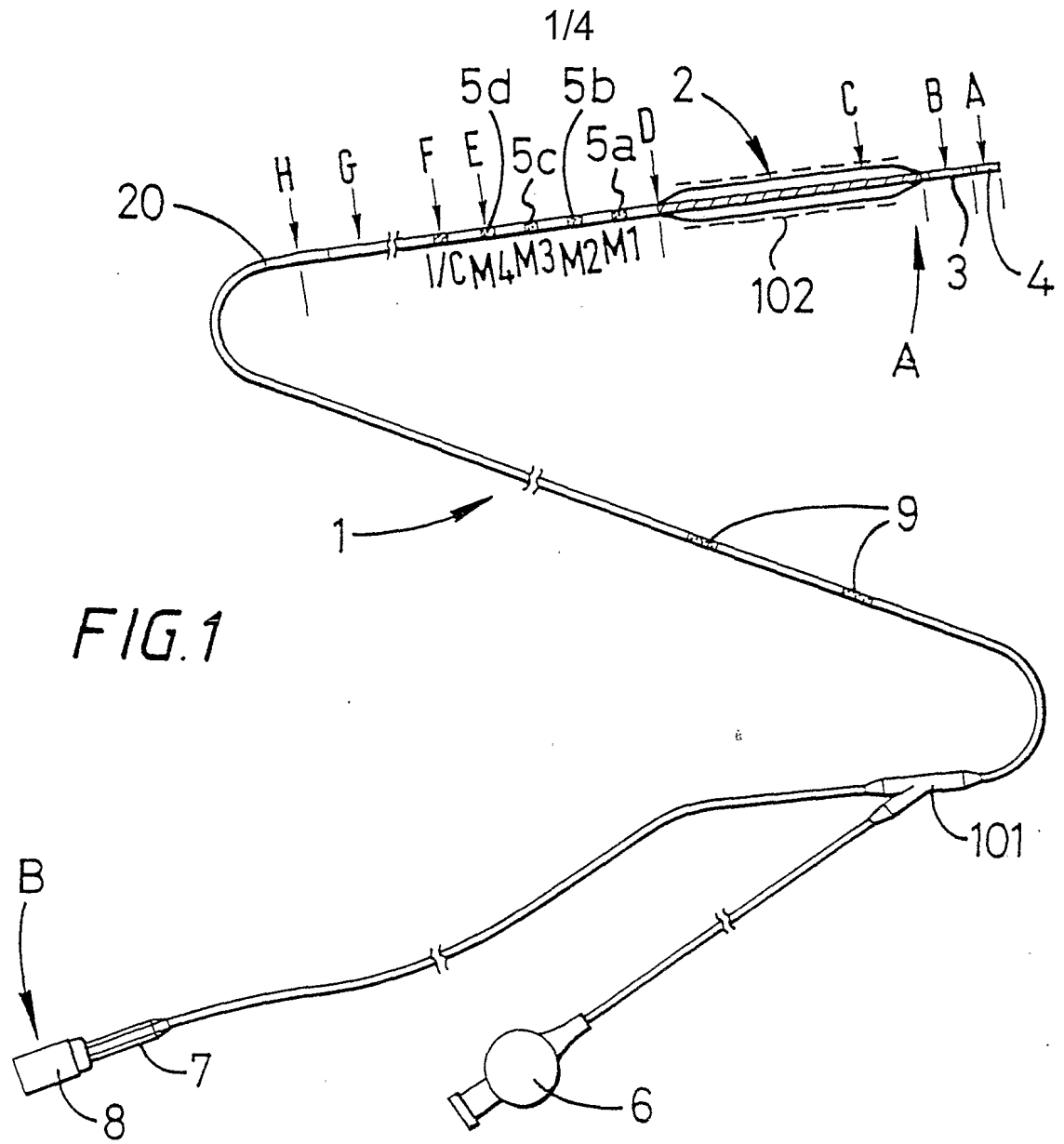

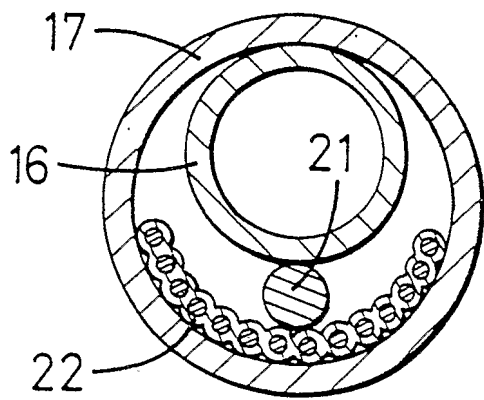

FIG. 4A

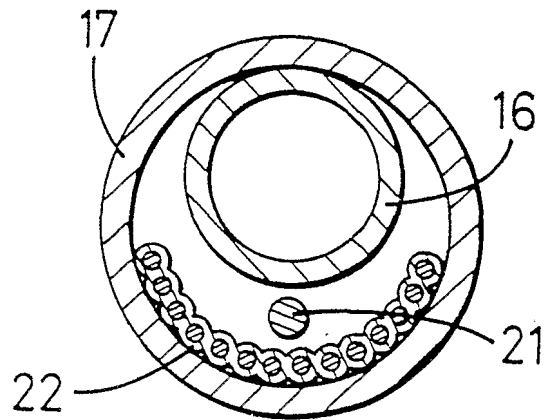

FIG. 4B

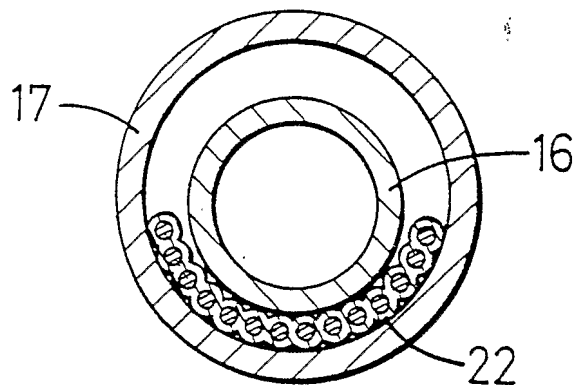

FIG. 4C

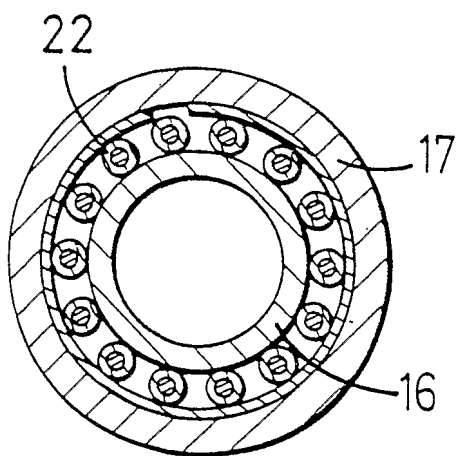

FIG. 4D

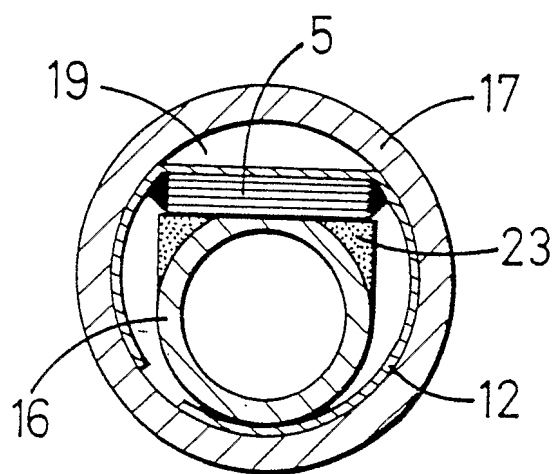
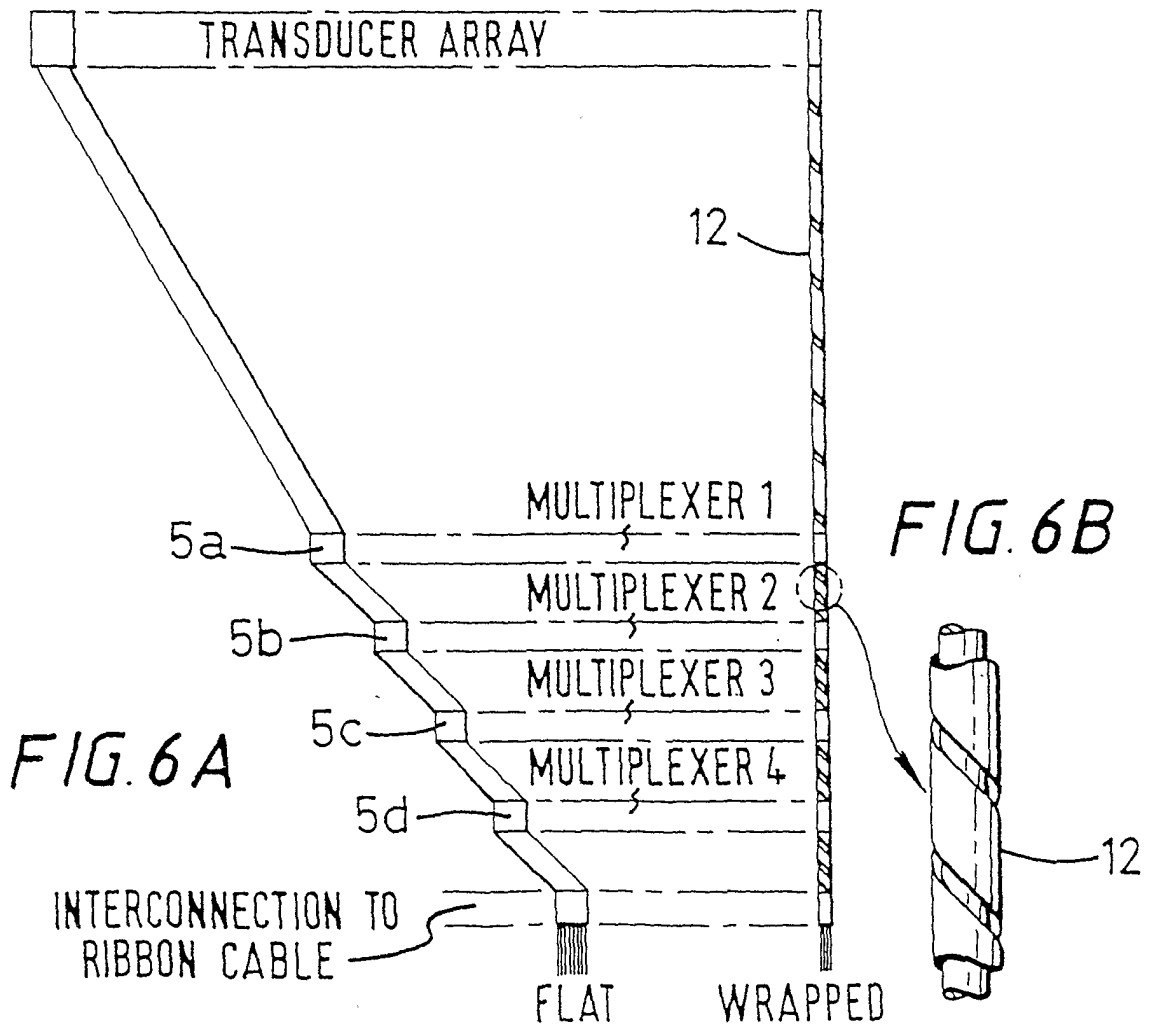
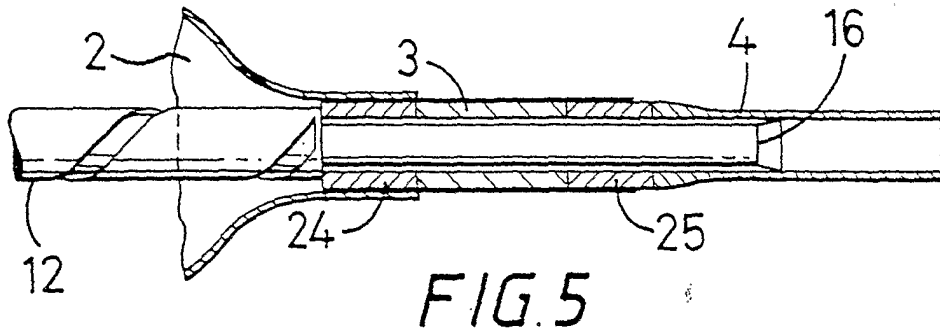
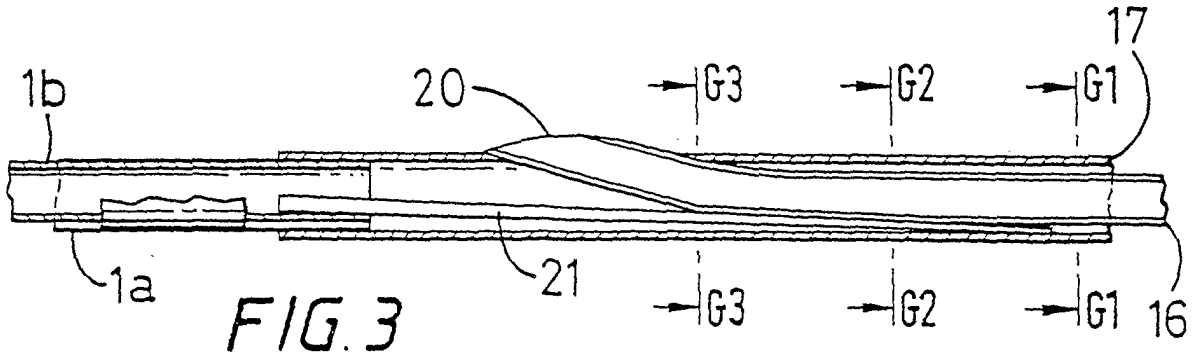

FIG. 4E

3/4



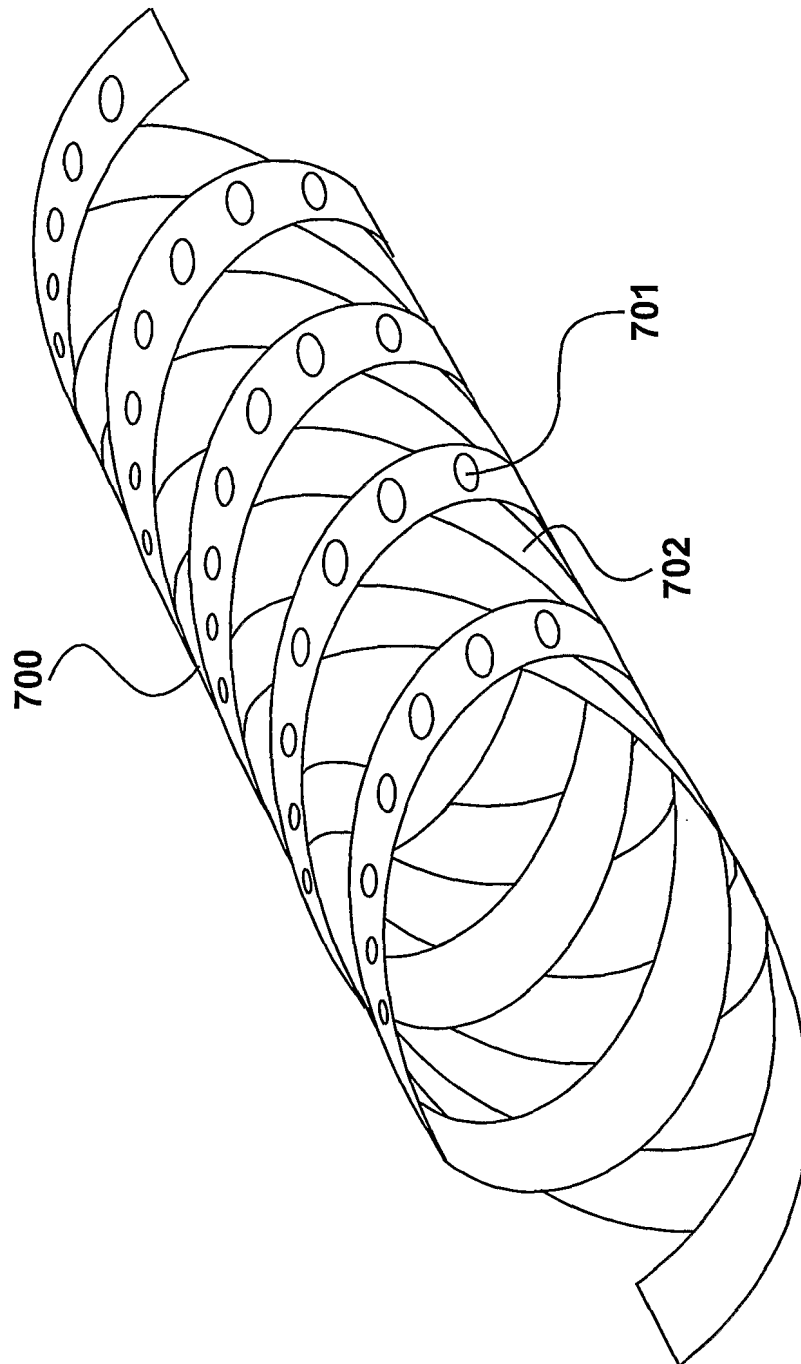

Figure 7

专利名称(译)	超声成像导管		
公开(公告)号	EP1303216A2	公开(公告)日	2003-04-23
申请号	EP2001949772	申请日	2001-07-20
[标]申请(专利权)人(译)	JOMED IMAGING		
申请(专利权)人(译)	JOMED IMAGING LIMITED		
当前申请(专利权)人(译)	JOMED IMAGING LIMITED		
[标]发明人	NIX ELVIN HOWES WILLIAM DICKINSON ROBERT WNENDT STEPHAN		
发明人	NIX, ELVIN HOWES, WILLIAM DICKINSON, ROBERT WNENDT, STEPHAN		
IPC分类号	A61B1/12 A61B8/12 A61F2/00 A61F2/88 A61F2/958 A61M29/02 A61B8/00		
CPC分类号	A61F2/958 A61B1/00082 A61B5/4839 A61B8/12 A61B8/4488 A61F2/88 A61F2250/0068 A61M25/104 A61M2025/1093 Y10T29/42 Y10T29/49005 Y10T29/49124 Y10T29/4913 Y10T29/49155		
优先权	2000017674 2000-07-20 GB		
其他公开文献	EP1303216B1		
外部链接	Espacenet		

摘要(译)

血管内超声成像导管设置有柔性电路，该柔性电路电耦合到安装在导管远端上的换能器阵列，柔性电路的一部分螺旋缠绕在导管周围，以增强电路的柔性。导管可以是球囊导管，其还设置有安装在球囊上的支架，该支架携带一种或多种药物，所述药物被设计成在通过球囊导管递送支架后被洗脱或洗涤到患者的血流中，进入患者血管系统内的目标区域。