



(11) **EP 2 219 509 B1**

(12) **EUROPEAN PATENT SPECIFICATION**

(45) Date of publication and mention of the grant of the patent:
16.10.2019 Bulletin 2019/42

(51) Int Cl.:
A61B 17/34 (2006.01) **A61B 1/00** (2006.01)
A61B 46/10 (2016.01) **A61B 8/08** (2006.01)
A61B 8/00 (2006.01) **A61B 90/00** (2016.01)

(21) Application number: **08856926.4**

(86) International application number:
PCT/US2008/085244

(22) Date of filing: **02.12.2008**

(87) International publication number:
WO 2009/073653 (11.06.2009 Gazette 2009/24)

(54) **NEEDLE GUIDE SYSTEM FOR USE WITH ULTRASOUND TRANSDUCERS TO EFFECT SHALLOW PATH NEEDLE ENTRY**

NADELFÜHRUNGSSYSTEM ZUR VERWENDUNG MIT ULTRASCHALLWANDLERN ZUR FLACHEN NADELEINFÜHRUNG

SYSTÈME DE GUIDAGE D'AIGUILLE DEVANT ÊTRE UTILISÉ AVEC DES TRANSDUCTEURS À ULTRASONS POUR PERMETTRE L'ENTRÉE D'UNE AIGUILLE DANS UN CHEMIN PEU PROFOND

(84) Designated Contracting States:
AT BE BG CH CY CZ DE DK EE ES FI FR GB GR HR HU IE IS IT LI LT LU LV MC MT NL NO PL PT RO SE SI SK TR

(30) Priority: **04.12.2007 US 5316 P**
08.01.2008 US 970797

(43) Date of publication of application:
25.08.2010 Bulletin 2010/34

(73) Proprietor: **Civco Medical Instruments Co., Inc.**
Kalona, IA 52247 (US)

(72) Inventors:
• **CERMAK, Craig, J.**
Riverside
Iowa 52327 (US)

- **CUMBERFORD, Brent, A.**
Iowa City
Iowa 52246 (US)
- **WILSON, Roger, F.**
Sarasota
Florida 34240 (US)
- **WHITMORE, Willet, F. III**
Longboat Key, Florida 34228 (US)

(74) Representative: **Delumeau, François Guy et al**
Cabinet Beau de Loménie
158, rue de l'Université
75340 Paris Cedex 07 (FR)

(56) References cited:
EP-A- 1 552 792 **WO-A-2006/041901**
US-A1- 2005 059 891 **US-B1- 6 361 499**
US-B1- 6 379 307 **US-B1- 6 475 152**
US-B1- 6 758 817

EP 2 219 509 B1

Note: Within nine months of the publication of the mention of the grant of the European patent in the European Patent Bulletin, any person may give notice to the European Patent Office of opposition to that patent, in accordance with the Implementing Regulations. Notice of opposition shall not be deemed to have been filed until the opposition fee has been paid. (Art. 99(1) European Patent Convention).

Description

BACKGROUND OF THE INVENTION

[0001] This invention relates generally to medical devices and more particularly to needle guide devices with ultrasound transducers.

[0002] It is a common medical practice to use a guide for releasable securement onto an ultrasound transducer to percutaneously guide a needle or some other puncture device to some desired location within the body of a patient. The patent literature includes various devices for such applications, such as those shown in United States Letters Patent Nos.: 5,052,396 (Wedel et al.), 5,076,279 (Arenson et al.), 5,623,931 (Wung et al.), 5,758,650 (Miller et al.), 5,941,889 (Cermak), 6,379,307 (Filly et al.), and 7087,024 (Pruter)

[0003] Document US 6 758 817 discloses an apparatus and method for guiding a needle in conjunction with a biopsy using a medical imaging device, where a non-reusable needle guide, grasps the sheathed bracket firm, and holds the same in a set position based upon a bullet-nose lock.

[0004] Document EP 1 552 792 describes a needle guide attached to the end of an ultrasonic probe.

[0005] Document US 6 361 499 describes a rotatable needle guide for attachment to an ultrasonic probe.

[0006] CIVCO Medical Instruments Co. Inc., the assignee of the subject invention through its related company CIVCO Medical Solutions, sells needle guide systems for use with ultrasonic transducers constructed in accordance with the above identified Filly et al. patent. Such systems consist of a custom reusable, non-sterile biopsy bracket or adaptor and a disposable, sterile snap-on needle guide. The bracket is sold under the trademark L17- 5 multi-angle bracket and the needle guide is sold under the trademark Infiniti needle guide. The bracket is in the form of a ring-like member arranged to be releasably secured about a portion of the distal periphery of the ultrasound transducer. A flexible plastic, sterile isolating cover is then placed over the adaptor and the transducer to isolate those components from the patient and to provide a sterile field. The needle guide is then releasably secured, e.g., snap-fit to the adaptor, so that a portion of the cover is interposed between it and the adaptor. The needle guide is arranged to enable the physician or other health care provider to guide the needle or some other penetrating device to a desired location within the body of the

patient. To that end, the needle guide basically comprises a pair of spaced apart plates. The needle or other puncture device is arranged to be placed between the plates and oriented at any desired angle to the central axis of the transducer so that the needle's tip can be inserted to any desired depth of penetration. The visualization of the positioning of the needle at the desired location is accomplished by the operation of the ultrasound transducer. The snap-fitting of the Infiniti needle guide to the L17-

5 bracket is achieved by means of a pair of aligned grooves at the bottom of the bracket, which are arranged to receive respective projections or bosses located on the bottom of the needle guide to enable the upper portion of the needle guide to be pivoted toward an upper portion of the bracket. The upper portion of the needle guide is in the form of an under-cut arcuate recess. The upper portion of the bracket is in the form of an arcuate surface, which is arranged to mate with the undercut recess in the needle guide. A finger projects from the upper portion of the needle guide adjacent the undercut recess to enable the physician to grasp that finger during the pivoting of the needle guide toward the bracket so as to deform the undercut recess slightly, whereupon the curved surface of the bracket can snap-fit into the recess, thereby releasably securing the needle guide to the bracket with the isolating cover interposed therebetween.

[0007] While the aforementioned needle guide system of CIVCO Medical Solutions is suitable for its intended purposes, it still leaves something desired from the standpoint of needle or other puncture device guidance. In particular, the CIVCO Medical Solutions needle guide system does not provide a predetermined path for the needle or other puncture member to take, i.e., the needle or other puncture member can be oriented at any angle between the plates of the needle guide. Thus, a need exists for a needle or other puncture device guidance system for use with ultrasound transducers that facilitates precise positioning along at least one predetermined path. The subject invention addresses that need.

BRIEF SUMMARY OF THE INVENTION

[0008] The puncture device guide system of the invention is defined in claim 1. Preferred embodiments are defined in the dependent claims.

[0009] In accordance with one aspect of this invention there is provided a puncture device guide system for use with an ultrasound transducer and a sterile cover to provide predictable trajectories for puncture devices at various depths. The puncture device guide system basically comprising a bracket and a puncture device guide. The bracket is arranged for releasable mounting on the ultrasound transducer, whereupon the sterile cover can be placed over the ultrasound transducer and the bracket mounted thereon. The puncture device guide is arranged to be releasably snap-fitted to the bracket with the sterile cover interposed therebetween. The guide includes a base portion and a movable member which together form a passageway establishing a predetermined angled path for a receipt of a puncture device to penetrate into the body of a patient to a desired depth. The puncture guide is openable, the movable portion can be pivoted away from the base portion, to enable the ultrasound transducer with the needle guide system mounted thereon to be removed from the patient, leaving the puncture device in place penetrating into the body of the patient.

[0010] In accordance with one aspect of this invention

the bracket includes a lower portion and the guide includes a lower portion. One of the lower portions of the bracket and the guide is in the form of a convex projection and the other of the lower portions of the bracket and the guide is in the form of a concave recess for mating receipt of the convex projection. This feature enables the guide to be pivoted about a pivot axis extending through the mating concave recess and convex projection in a first rotational direction to snap-fit the guide to the bracket.

[0011] In accordance with another aspect of this invention the movable member is biased to normally be in the pivotably closed position thereby establishing the predetermined angled path for a receipt of the puncture device.

[0012] In accordance with a further aspect of the resent disclosure, the system includes plural puncture device guides. Each of those plural guides is constructed to establish a different, respective predetermined angled path for a receipt of the puncture device.

[0013] In accordance with another exemplary aspect of this disclosure, the puncture device guide includes plural predetermined paths for receipt of a needle or other puncture device to establish plural preselected depths of penetration that can be achieved.

[0014] In accordance with another exemplary aspect of this disclosure, the bracket is configured to be mounted on the ultrasound transducer so that the guide is located facing a transverse side of the ultrasonic transducer.

[0015] An exemplary method for introducing a puncturing device into the body of a living being utilizing an ultrasound transducer to provide a predictable trajectory for the puncturing device at various depths is also disclosed. The method basically comprises providing a guide system comprising a bracket and a puncture device guide, releasably mounting the bracket on the ultrasound transducer, whereupon a sterile cover can be placed over the ultrasound transducer and the bracket mounted thereon. The method further entails releasably attaching the guide to the bracket with the sterile cover interposed therebetween to establish a predetermined angled path for a receipt of the puncturing device to penetrate into the body of a patient to a desired depth. The guide is openable to enable the ultrasound transducer and the needle guide system to be removed, leaving the puncture device in place penetrating into the body of the patient.

BRIEF DESCRIPTION OF SEVERAL VIEWS OF THE DRAWINGS

[0016] The invention will be described in conjunction with the following drawings in which like reference numerals designate like elements and wherein:

Fig. 1 is an exploded isometric view of one exemplary embodiment of a puncture device (e.g., needle) guide system making use of an adaptor and a needle guide which are constructed in accordance with this invention for use with a conventional ultrasound transducer and a sterile cover;

Fig. 2 is a front elevation view of the system shown in Fig. 1;

Fig. 3 is an isometric view of the adaptor shown in Fig. 1;

Fig. 4 is another isometric view of the adaptor shown in Fig. 1;

Fig. 5 is a slightly enlarged isometric view of the adaptor shown in Fig. 1, but with a portion of it, namely, the passageway forming clamp, removed;

Fig. 6 is a slightly enlarged isometric view of the passageway forming clamp of the adaptor shown in Fig. 1;

Fig. 7 is an exploded isometric view of a second exemplary embodiment of a puncture device (e.g., needle) guide system making use of an adaptor and a needle guide which are constructed in accordance with this disclosure for use with a conventional ultrasound transducer;

Fig. 8 is a front plan view of the needle guide shown in Fig. 7;

Fig. 9 is a rear plan view of the needle guide shown in Fig. 7;

Fig. 10 is an exploded isometric view of the needle guide shown in Fig. 7;

Fig. 11 is an illustration of an ultrasound transducer making use of a transversely mounted needle guide showing an exemplary image of the needle being inserted into an artery;

Fig. 12 is an illustration of an ultrasound transducer making use of a longitudinally mounted needle guide showing the needle being inserted into an artery; and

Fig. 13 is a top plan view of a kit having a plurality of needle guides for use with the adaptor shown in Figs. 1 - 6 to establish penetration depths of 0.5 cm, 1.0 cm, 1.5 cm, 2.0 cm, 2.5 cm, 3.0 cm and 3.5 cm.

DETAILED DESCRIPTION OF THE PREFERRED EMBODIMENTS

[0017] Referring now to the drawing wherein like reference numbers refer to like parts there is shown at 20 in Fig. 1 one exemplary embodiment of a puncture device guidance system for use with an ultrasound transducer constructed in accordance with this invention. The ultrasound transducer 10 is shown by the phantom lines in Fig. 1. Before describing the details of the system 20 a brief description of the ultrasound transducer 10 is in order. To that end, the ultrasound transducer 10 which is shown by the phantom lines is typical of the construction of conventional medical applications and typically has a central axis which is perpendicular to its distal end or patient engaging face. The cross section of the distal end is of a generally rounded rectangular or ovoid shape having a longer or major longitudinal axis and a shorter or minor transverse axis. Placement of a puncture device is typically accomplished by means of some needle guide mounted on one of the longitudinally extending sides of the transducer or on one of the transversely extending

sides. In either case the needle or some other puncture device is arranged to be brought in at an angle intersecting the transducer's central axis so that the tip of the needle or other puncture device is at a desired depth within the ultrasound transducer's imaging plane. Thus, the ultrasound transducer can provide an image of the field as the needle or puncture device is positioned in the imaging plane.

[0018] In Fig. 11 the ultrasound transducer 10 is illustrated showing a needle guide, like that of the subject invention, mounted "transversely" on the transducer. By "transversely" mounted it is meant that the needle guide is mounted so that the path that the needle takes with respect to the imaging plane intersects the imaging plane, thereby providing a cross section of the needle and the anatomic structure of the patient in which the needle is located, e.g., within an artery. The subject invention, is particularly suited for transverse mounting on the ultrasound transducer, but can also be arranged for longitudinal mounting. A longitudinally mounted needle guide is shown in the illustration of Fig. 11. As can be seen therein, with such an arrangement the angled path that the needle takes is in the imaging plane of the transducer.

[0019] The puncture device guidance system 20 basically comprises a bracket or adaptor 22 and a needle guide 24. The adaptor 22 is an integral unit which is best seen in Figs. 1, 3, 4 and 5 and basically comprises a ring-like member having a hollow interior space shaped to accommodate the distal end portion of the transducer 10. The adaptor can be fabricated of any suitable material, e.g., molded of any suitable plastic. The ring-like portion of the adaptor is made up of an opposed pair of longitudinally extending side walls 26 and an opposed pair of transversely extending end walls 28, all of which are conjoined to one another. Since there are numerous shaped ultrasound transducers commercially available the shape of the inner surfaces of the side walls and end walls forming the ring-like portion of the adaptor will be configured to accommodate the particular transducer to which it is to be mounted. The adaptor is arranged to be releasably secured to the transducer via either frictional engagement or mechanical means, e.g., mating components of the transducer and adaptor. In either case the adaptor 22 is a reusable member that is mounted on the transducer 10. Then a conventional, flexible sterile cover 12, like shown in Fig. 1, is placed over the transducer on which the bracket is mounted.

[0020] The needle guide 24 is a sterile, preferably disposable member, which is arranged to be readily mounted on the adaptor 22 with the flexible, sterile cover 12 interposed therebetween, so that the needle guide is resistant to accidental disconnection, but can be readily removed (dismounted) when desired. In accordance with a preferred aspect of this invention the needle guide 24 is arranged to be connected to (mounted on) the adaptor 22 by means of a snap-fit connection. That connection will now be described. To that end, as can be seen in

Figs. 1 - 5 one of the longitudinally extending side walls 26 of the adaptor 22 includes a projection 30 extending outward from the outer face of that side wall. A channel 32 is provided in the outer surface of the projection 30, with the top portion of the channel forming a convex surface 34 and with the lower portion of the channel being somewhat linear. A pair of flanges 36 extends along the sides of the channel 32. The lower end of each flange 36 is in the form of a semi-circular recess 38. Each of the recesses 38 is arranged to receive a respective boss, to be described later, of the needle guide 24 to pivotably snap-fit the guide member to the adaptor 22.

[0021] The needle guide 24 is best seen in Figs. 1 and 2 and basically comprises a generally wedge shaped body 40 having an undercut recess 42 in the top portion of the front face of the body 40. The undercut recess is of a concave shape to mate with the convex surface 32 of the projection 30 of the adaptor 22. The remainder of the front face of the needle guide's wedge shaped body is in the form of a linear surface 44 whose width is just slightly less than the width of the channel 34 of the adaptor's projection 30 so that it can be received within the linear portion of that channel when the needle guide is mounted on the adaptor. The upper portion of the needle guide body 40 is in the form of a finger 46. A stop 48 projects downward from the finger 46 and forms the margin for the upper end of the undercut recess 42. Two semi-circular rods or bosses 50 project outward from the lower portion (the apex) of the needle guide body 40. The bosses 50 are axially aligned with each other.

[0022] The mounting of the needle guide 24 onto the adaptor 22 after the cover 12 has been placed over the transducer is accomplished as follows. The needle guide is juxtaposed so that its front face is disposed opposite to the channel 32 in the adaptor's projection 30, with the two bosses 50 of the needle guide being located within respective recesses 38 of the adaptor 22. The user then pivots the needle guide 24 towards the adaptor 22, using the finger 46 as a pull tab. This causes the stop 48 to slide along the upper convex surface 32 of the adaptor until it reaches the end of that surface, whereupon the finger 46 snaps downward, locking the stop 48 in place so that the convex surface 34 of the adaptor's projection 30 is resident within the undercut recess 42 of the guide member.

[0023] The needle guide 24 includes a passageway, to be described later, that establishes a predetermined path through which the needle may be extended to reach a desired depth of penetration. In particular, as will be described in considerable detail later the passageway in the needle guide is arranged to extend at an acute angle to the central axis of the transducer when it is mounted on the adaptor so that the intersection of the angled needle path with the central longitudinal axis of the transducer will be at the desired depth of penetration. That depth of penetration may be any desired depth. In accordance with one preferred embodiment of this disclosure plural needle guides may be provided, each establishing a dif-

ferent respective angular path, for use with a single adaptor to create different depths of penetration. For example, Fig. 13 shows a kit of plural needle guides 24A, 24B, 24C, 24D, 24E, 24F and 24G for producing a series of depths of penetration, e.g., 0.5 cm, 1.0 cm, 1.5 cm, 2.0 cm, 2.5 cm, 3.0 cm and 3.5 cm, respectively. The needle guides 24A, 24B, 24C, 24D, 24E, 24F and 24G are preferable molded as a unit 200 of any suitable plastic material and are provided in that form for use with an adaptor 22. When any particular needle guide is selected for use all that is required is to break it away from the other needle guides via the various breakaway joints 202. For example, if the physician wishes to have a needle penetration of 1.5 cm, e.g., to place the needle into an artery, the needle guide 24C would be selected and broken off from the remaining needle guides. Needle guide 24C is then be mounted on the adaptor in the manner as described above to establish a guide path taking the needle to a depth of penetration in the transducer's image plane of 1.5 cm.

[0024] The angular path established by each needle guide 24 is in the form of a linear passageway 52 (Fig. 4) which extends along the angled outside face of the wedge shaped body 40 of the needle guide. The passageway 52 is formed by the cooperation of an angularly extending linear groove 54 (Fig. 5) in the outside face of the guide member's wedge shaped body and a cooperating groove 56 (Fig. 6) in the inner surface of pivotable member 58. The pivotable member 58 is pivotably connected to the body 40 of the guide member by a hinge connection, to be described later. Suffice it for now to state that the pivotable member is biased, by means to be described shortly, so that it is normally in its closed position or orientation like shown in Figs. 1 - 4, thereby establishing the predetermined angular path for the needle. The pivotable member is arranged to be moved, i.e., pivoted, to an open orientation to open the linear passageway 52 to enable the transducer and its attached needle guide system 20 to be removed from the patient, while leaving the needle in place in the patient.

[0025] As best seen in Fig. 6 the member 58 includes an elongated curved wall portion 60 (whose inner surface forms the groove 56) and a handle 62. A linear hinge pin 64 projects inward from the handle 62 and extends parallel to the groove 56. The hinge pin 64 is arranged to be pivotably received within a slot 66 in the wedge shaped body 40. The hinge pin is held in place within the slot by a retainer 68. A small, resilient arcuate shaped tab 70 is located on the inner surface of the handle 62 close to the hinge pin 64. The tab 70 projects outward from the member 58 and is arranged to abut a small ridge 72 (Fig. 5) on the body 40 of the guide member to apply biasing force to the member 58 to cause it to be in its normally closed orientation.

[0026] In order to facilitate the introduction of the needle into the passageway so that it can be guided along the passageway to its desired position within the body of the patient the proximal end of the passageway is flared

at 74. The guide member 24 is arranged to be able to accommodate needles or other puncture devices of varying gauges. Thus, the guide member can be fabricated so that size of the passageway 52 is will accommodate needles of 18, 21 or 21 gauge. In fact, the passageway can be made to accommodate any size needle or other puncture device. In the exemplary embodiment shown in Figs. 1 - 6 the needle guide is arranged for use with an 18 gauge needle. This is indicated by indicia bearing the number "18" appearing on the handle 62 of the needle guide.

[0027] The pivotable member 58 of the needle guide is arranged to be opened, i.e., pivoted away from the wedge shaped body 40, by pressing on the handle 62. This action causes the resilient tab 70 to bend or flex, whereupon the pivotable member 58 pivots outward from its closed orientation to an open orientation (not shown). In the open orientation the entire length of passageway 52 is accessible laterally. This enables the system 20 and the transducer 10 on which it is mounted to be removed from the patient leaving the needle in place in the patient, i.e., the combined transducer 10 and system 20 can be slid laterally off of the needle leaving the needle undisturbed.

[0028] As should be appreciated by those skilled in the art the needle guide attachment geometry as described above provides for very secure attachment without damaging the cover between the bracket and the needle guide. When the guide is attached to the bracket the finger (flexure) portion exerts pressure on the cylindrical bosses maintaining their position in the bracket's locating feature. When the device is used the routine manipulation of the transducer against the patient may exert pressure against the cylindrical bosses into the locating feature thus making the fit of the guide more secure. The flexure feature allows the guide to be attached and removed without friction between the bracket and the guide which is the most common cause of cover damage during guide attachment.

[0029] The secure fit of the as achieved by the subject is of considerable importance in transverse entry procedures, where the guide may extend beyond the bracket and be dislodged during routine manipulation of the transducer against the patient.

[0030] In Figs. 7 - 10 there is shown another embodiment of a puncture device guide system 100 constructed in accordance with this disclosure. The system 100 is similar in many respects to system 20, except that its guide member 124 is arranged to provide plural predetermined paths, each establishing a different depth of penetration, whereas with the system 20 only a single depth of penetration can be effected by any given guide member 24. The system 100 basically comprises an adaptor or bracket 122 on which the guide member 124 is pivotably snap-fit. The adaptor 122 is similar in construction to the adaptor 22 in that it includes plural walls which conjoin to form a ring-like member for frictional or mechanical mounting on the distal end portion of the ul-

trasound transducer. The adaptor includes a projection 130 constructed similarly to projection 30 of the adaptor 22. Thus, the common structural element of the projection 130 will be given the same reference numbers as the projection 30 of the adaptor 22. Moreover, the details of the construction and operation of the projection 130 will not be reiterated in the interest of brevity. The guide member 124 is similar in construction to the guide member 24 insofar as its pivotable snap-fitting mounting on the adaptor 122 is concerned. Thus, the common structural elements of the means for snap connecting the guide member 124 to the adaptor 122 will be given the same reference numbers as the corresponding means for snap connecting the guide member 24 to the adaptor 22 and the description of the operation for snap connecting the guide member 124 to the adaptor 122 will be omitted in the interest of brevity.

[0031] The means of the guide member 124 for establishing the plural angled paths for the needle or other puncture devices will now be described. To that end as shown in Fig. 7, the guide member 124 includes a wedge shaped body 140 having plural elongated, linear grooves or slots 142, 144, 146 and 148. Since the slots 142, 144, 146 and 148 are open, the guide member 124 includes associated component in the form of pivotable cover plates 150, 152, 154 and 156, respectively, which are arranged to be pivoted to a closed position to seal the length of those slots, leaving only the distal and proximal ends of the slots open. Thus, when the cover plates are in their closed position, not shown, they cooperate with their associated slots to form the respective enclosed needle guiding passageways of the guide 124.

[0032] As best seen in Fig. 10 each of the four cover plates 150, 152, 154 and 156 includes a pair of mounting pins 158 projecting perpendicularly from its rear surface. The pins 158 extend through arcuate slots 160 in the wedge shaped body 140 for fixed securement in respective apertures 162 in a pivot plate 164. The pivot plate is disposed on the opposite face of the guide member body 140 than the covers 150, 152, 154 and 156 so that the guide member body 140 is interposed between the cover plates and the pivot plate 164. The pivot plate includes an arm 166 which flexes as a spring when connected to the guide member body 140 between a pair of projecting stops 168. The pivot plate includes a handle 170 (Figs. 9 and 10) to enable the user to readily pivot the pivot plate between the stops 168. The pivot plate is arranged to be pivoted outward, i.e., in a direction toward the outside face 172 of the guide member body 140 to cause the cover plates 150, 152, 154 and 156 secured to the pivot plate to also pivot in that direction, thereby causing them to enclose their associated slots. This action forms four, enclosed needle guide passageways for guiding a needle or other puncture device through it. In particular, the user can insert the needle or other puncture device into and through the desired passageway to percutaneously introduce the needle or other puncture device into the patient's body to the depth of penetration as estab-

lished by the angularity of the selected passageway.

[0033] In the exemplary embodiment shown, the slot 142 extends at an acute to the front face of the wedge shaped body 140 to establish a depth of penetration of 2.5 cm, the slot 144 extends at an acute to the front face of the wedge shaped body 140 to establish a depth of penetration of 1.5 cm, the slot 146 extends at an acute to the front face of the wedge shaped body 140 to establish a depth of penetration of 1.0 cm and the slot 148 extends at an acute to the front face of the wedge shaped body 140 to establish a depth of penetration of 0.5 cm. As best seen in Fig. 8 the proximal end or entryway of each of the slots 142, 144, 146 and 148 is flared to facilitate the introduction of a needle or other puncture device therein.

[0034] In order to remove the system 100 and the transducer 10 on which it is mounted from the patient while leaving the needle or other puncture device in place undisturbed, all that is required is to pivot the pivot plate away from the outer face 170, thereby causing the associated pivot plates to pivot to the open position, i.e., a position laterally of their associated slots as shown in Figs. 7 and 8. Once the slots are open the combined transducer 10 and system 100 can be slid laterally off of the needle leaving the needle undisturbed.

[0035] While the invention has been described in detail and with reference to specific embodiments thereof, it will be apparent to one skilled in the art that various changes and modifications can be made therein without departing from the scope of the invention defined by the claims.

Claims

1. A puncture device guide system for use with an ultrasound transducer (10) and a sterile cover (12) to provide predictable trajectories for puncture devices at various depths, said puncture device guide system comprising :

a bracket (22) ; and
a puncture device guide (24),
said bracket (22) being arranged for releasable mounting on the ultrasound transducer (10), whereupon the sterile cover (12) can be placed over the ultrasound transducer (10) and the bracket (22) mounted thereon, the puncture device guide system being **characterized in that:**

said bracket (22) including a first lower portion and said puncture device guide including a second lower portion,
one of said first lower portion of said bracket and said second lower portion of said puncture device guide being in the form of a convex projection (50) and the other of said first lower portion of said bracket and said sec-

ond lower portion of said puncture device guide being in the form of a concave recess (38) for mating receipt of said convex projection,

whereupon said puncture device guide (24) can be pivoted as a unit about a pivot axis extending through the mating concave recess and convex projection in a first rotational direction to effect a releasable snap-fitting of said puncture device guide (24) to said bracket (22), said puncture device guide being arranged to be readily attached to said bracket with the sterile cover interposed therebetween to establish a predetermined angled path for a receipt of a puncture device to penetrate into the body of a patient to a desired depth, said puncture device guide being openable to enable the ultrasound transducer and the puncture device guide system to be removed, leaving the puncture device in place penetrating into the body of the patient,

wherein said puncture device guide comprises a base member (40) and a movable member (58), said moveable member being pivotably connected to said base member, whereupon when said moveable member is in a pivotably closed position a passageway (52) is formed between said moveable member and said base member, said passageway establishing said predetermined angled path for a receipt of the puncture device, such that when said moveable member is in an open position said passageway is accessible laterally in a plane defined by a central axis of said transducer and a longitudinal axis of said passageway, wherein said movable member (58) is biased to normally be in said pivotably closed position.

2. The puncture guide system of Claim 1 wherein said first lower portion of said bracket forms said concave recess (38) and said lower portion of said guide forms said convex projection (50).
3. The puncture guide system of Claim 2 wherein said bracket includes a second portion in the form of a convex surface (32) and said guide includes a second portion in the form of a concave recess (42) for mating, snap-fit receipt of said convex surface when said guide is pivoted about said pivot axis in said first rotational direction.
4. The puncture guide system of Claim 1 or 3 wherein the ultrasound transducer (10) has a major longitudinal axis, a minor transverse axis, a longitudinal side extending along said major longitudinal axis and a transverse side extending along said minor longitu-

dinal axis, and wherein said bracket (22) is configured to be mounted on the ultrasound transducer so that said guide is located facing the transverse side of the ultrasound transducer.

Patentansprüche

1. Punktionsvorrichtungsführungssystem zur Verwendung mit einem Ultraschallwandler (10) und einer sterilen Abdeckung (12), um vorhersehbare Bewegungsbahnen für Punktionsvorrichtungen bei verschiedenen Tiefen bereitzustellen, wobei das Punktionsvorrichtungsführungssystem umfasst:

eine Halterung (22) und
eine Punktionsvorrichtungsführung (24),
wobei die Halterung (22) zur lösbaren Befestigung an dem Ultraschallwandler (10) angeordnet ist,
worauf die sterile Abdeckung (12) über dem Ultraschallwandler (10) und der darauf montierten Halterung (22) angeordnet werden kann, wobei das Punktionsvorrichtungsführungssystem **dadurch gekennzeichnet ist, dass:**

die Halterung (22) einen ersten unteren Abschnitt aufweist und die Punktionsvorrichtung einen zweiten unteren Abschnitt aufweist,

einer von dem ersten unteren Abschnitt der Halterung und dem zweiten unteren Abschnitt der Punktionsvorrichtungsführung in der Form eines konvexen Vorsprungs (50) ist und der andere von dem ersten unteren Abschnitt der Halterung und dem zweiten unteren Abschnitt der Punktionsvorrichtungsführung in der Form einer konkaven Aussparung (38) zur Aufnahme des konvexen Vorsprungs ist,

worauf die Punktionsvorrichtungsführung (24) als Einheit um eine Schwenkachse geschwenkt werden kann, die sich durch die ineinandergreifende konkave Vertiefung und den konvexen Vorsprung in einer ersten Drehrichtung erstreckt, um eine lösbare Schnappverbindung der Punktionsvorrichtungsführung (24) an der Halterung (22) zu bewirken,

wobei die Punktionsvorrichtungsführung so angeordnet ist, dass sie leicht an der Halterung befestigt werden kann, wobei die sterile Abdeckung dazwischenliegend angeordnet ist, um eine vorbestimmte angewinkelte Bahn für eine Aufnahme einer Punktionsvorrichtung festzulegen, um in den Körper eines Patienten in einer gewünschten Tiefe einzudringen,

- wobei die Punktionsvorrichtungsführung zu öffnen ist, um zu ermöglichen, dass der Ultraschallwandler und das Punktionsvorrichtungs-Führungssystem entfernt werden können, wobei die Punktionsvorrichtung an der Stelle verbleibt, an der sie in den Körper des Patienten eindringt,
- wobei die Punktionsvorrichtungsführung ein Basiselement (40) und ein bewegliches Element (58) umfasst, wobei das bewegliche Element schwenkbar mit dem Basiselement verbunden ist, woraufhin, wenn sich das bewegliche Element in einer schwenkbar geschlossenen Position befindet, ein Durchgang (52) zwischen dem beweglichen Element und dem Basiselement gebildet wird, wobei der Durchgang die vorbestimmte angewinkelte Bahn für eine Aufnahme der Punktionsvorrichtung derart festlegt, dass, wenn sich das bewegliche Element in einer offenen Position befindet, der Durchgang seitlich in einer Ebene zugänglich ist, die durch eine Mittelachse des Wandlers und eine Längsachse des Durchgangs definiert ist, wobei das bewegliche Element (58) vorgespannt ist, um sich normalerweise in der schwenkbar geschlossenen Position zu befinden.
2. Punktionsführungssystem nach Anspruch 1, wobei der erste untere Abschnitt der Halterung die konkave Aussparung (38) bildet und der untere Abschnitt der Führung den konvexen Vorsprung (50) bildet.
 3. Punktionsführungssystem nach Anspruch 2, wobei die Halterung einen zweiten Abschnitt in der Form einer konvexen Oberfläche (32) aufweist und die Führung einen zweiten Abschnitt in der Form einer konkaven Aussparung (42) zur ineinandergreifenden Schnappverbindungsaufnahme der konvexen Oberfläche aufweist, wenn die Führung um die Schwenkachse in der ersten Drehrichtung geschwenkt wird.
 4. Punktionsführungssystem nach Anspruch 1 oder 3, wobei der Ultraschallwandler (10) eine Hauptlängsachse, eine Nebenquerachse, eine Längsseite, die sich entlang der Hauptlängsachse erstreckt, und eine Querseite, die sich entlang der Nebenlängsachse erstreckt, aufweist, und wobei die Halterung (22) konfiguriert ist, um an dem Ultraschallwandler angebracht zu werden, so dass die Führung der Querseite des Ultraschallwandlers zugewandt angeordnet ist.

Revendications

1. Système de guidage de dispositif de piqûre destiné

à être utilisé avec un transducteur à ultrasons (10) et un couvercle stérile (12) pour fournir des trajectoires prévisibles pour les dispositifs de piqûre à différences profondeurs, ledit système de guidage de dispositif de piqûre comprenant :

un support (22) ; et
un guide de dispositif de piqûre (24),
ledit support (22) étant agencé pour être monté, de manière amovible, sur le transducteur à ultrasons (10),
après quoi le couvercle stérile (12) peut être placé sur le transducteur à ultrasons (10) et le support (22) monté sur ce dernier, le système de guidage de dispositif de piqûre étant **caractérisé en ce que** :

ledit support (22) comprend une première partie inférieure et ledit guide de dispositif de piqûre comprend une seconde partie inférieure,

l'une parmi ladite première partie inférieure dudit support et ladite seconde partie inférieure dudit guide de dispositif de piqûre se présente sous la forme d'une saillie concave (50) et l'autre parmi ladite première partie inférieure dudit support et ladite seconde partie inférieure dudit guide de dispositif de piqûre se présente sous la forme d'un évidement concave (38) pour la réception de couplage de ladite saillie convexe,
après quoi ledit guide de dispositif de piqûre (24) peut être pivoté comme une unité autour d'un axe de pivot qui s'étend à travers l'évidement concave et la saillie convexe de couplage dans une première direction de rotation pour effectuer un encliquetage amovible dudit guide de dispositif de piqûre (24) par rapport audit support (22),
ledit guide de dispositif de piqûre étant agencé pour être fixé facilement audit support avec le couvercle stérile intercalé entre eux afin d'établir une trajectoire coudée prédéterminée pour une réception d'un dispositif de piqûre afin de pénétrer dans le corps d'un patient jusqu'à une profondeur souhaitée,

ledit guide de dispositif de piqûre pouvant s'ouvrir pour permettre au transducteur à ultrasons et au système de guidage de dispositif de piqûre d'être retirés laissant le guide de piqûre pénétrant dans le corps du patient en place,

dans lequel ledit guide de dispositif de piqûre comprend un élément de base (40) et un élément mobile (58), ledit élément mobile étant raccordé, de manière pivotante, audit élément de base, après quoi lorsque

- ledit élément mobile est dans une position fermée de manière pivotante, une voie de passage (52) est formée entre ledit élément mobile et ledit élément de base, ladite voie de passage établissant ladite trajectoire coudée prédéterminée pour une réception du dispositif de piqûre, de sorte que lorsque ledit élément mobile est dans une position ouverte, ladite voie de passage est accessible latéralement dans un plan défini par un axe central dudit transducteur et un axe longitudinal de ladite voie de passage, dans lequel ledit élément mobile (58) est sollicité pour être normalement dans ladite position fermée de manière pivotante. 5
10
15
2. Système de guidage de piqûre selon la revendication 1, dans lequel ladite première partie inférieure dudit support forme ledit évidement concave (38) et ladite partie inférieure dudit guide forme ladite saillie convexe (50). 20
3. Système de guidage de piqûre selon la revendication 2, dans lequel ledit support comprend une seconde partie se présentant sous la forme d'une surface convexe (32) et ledit guide comprend une seconde partie se présentant sous la forme d'un évidement concave (42) pour la réception par encliquetage de ladite surface convexe lorsque ledit guide est pivoté autour dudit axe de pivot dans ladite première direction de rotation. 25
30
4. Système de guidage de piqûre selon la revendication 1 ou 3, dans lequel le transducteur à ultrasons (10) a un axe longitudinal majeur, un axe transversal mineur, un côté longitudinal s'étendant le long dudit axe longitudinal majeur et un côté transversal s'étendant le long dudit axe longitudinal mineur, et dans lequel ledit support (22) est configuré pour être monté sur le transducteur à ultrasons de sorte que ledit guide est positionné en face du côté transversal du transducteur à ultrasons. 35
40
45
50
55

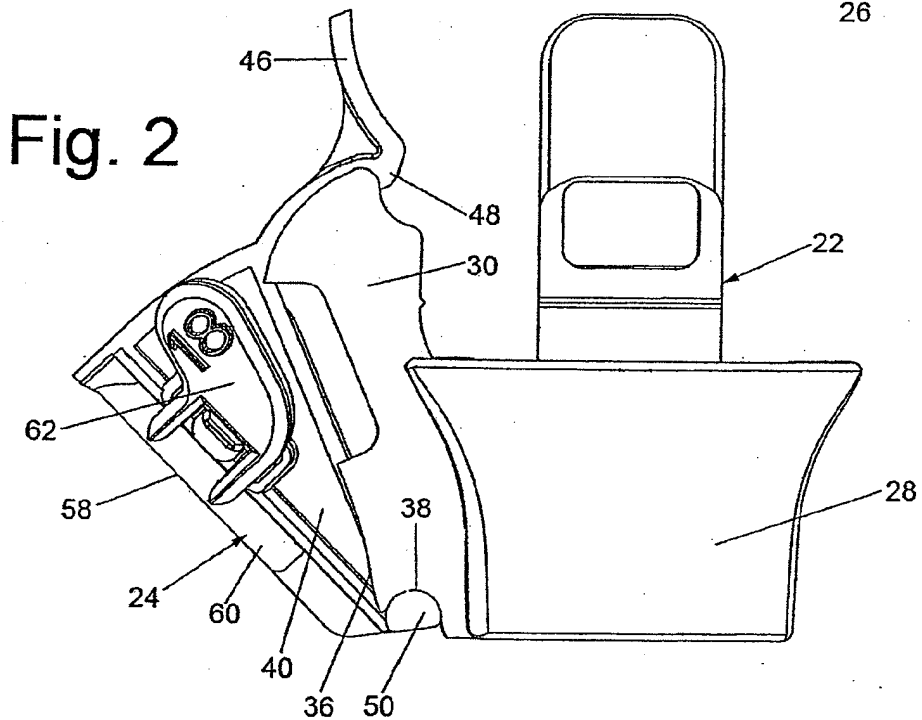
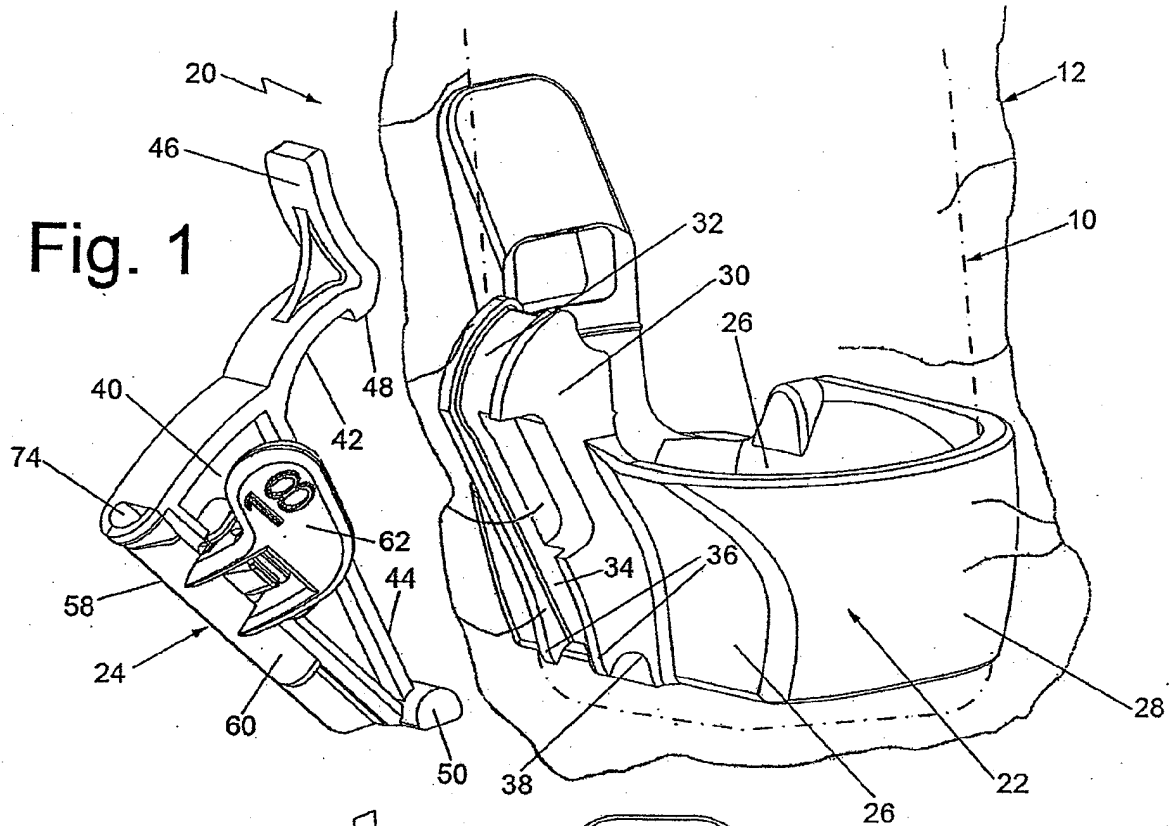

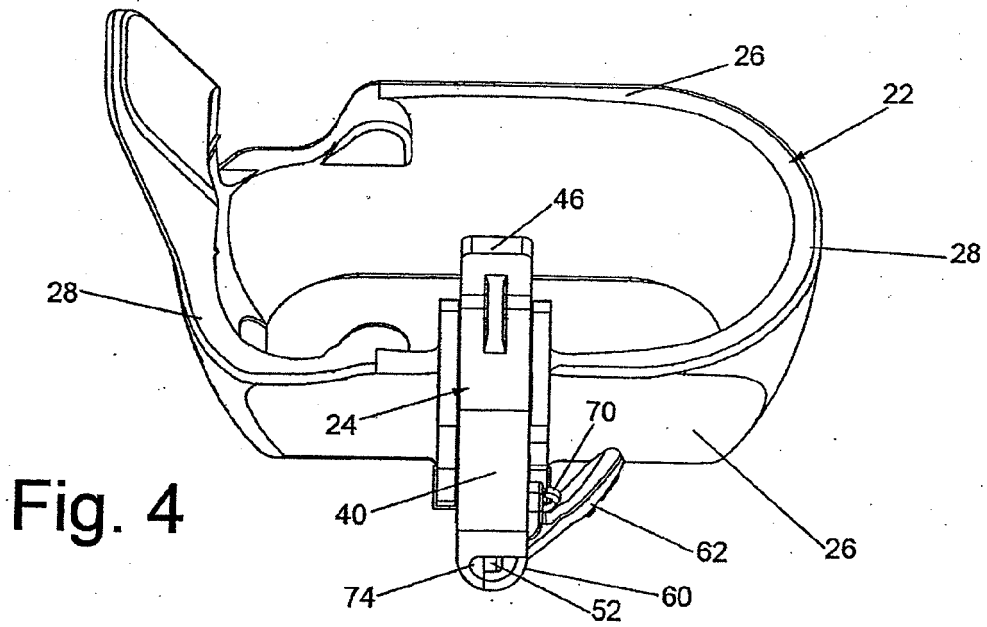
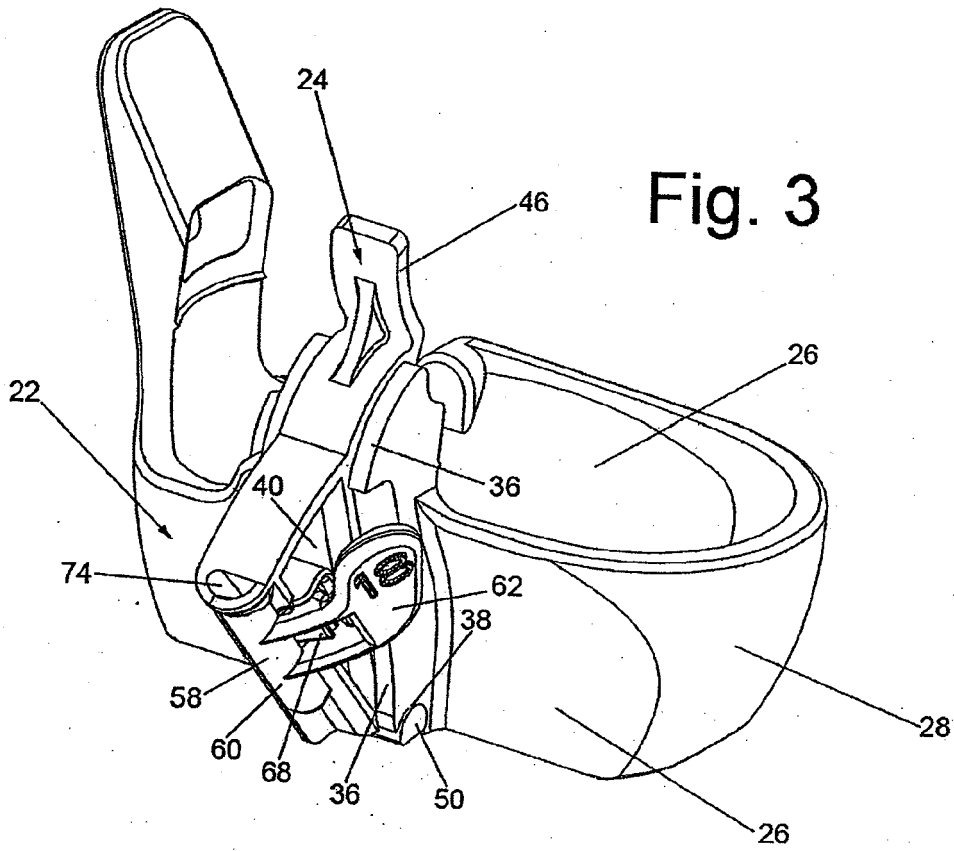

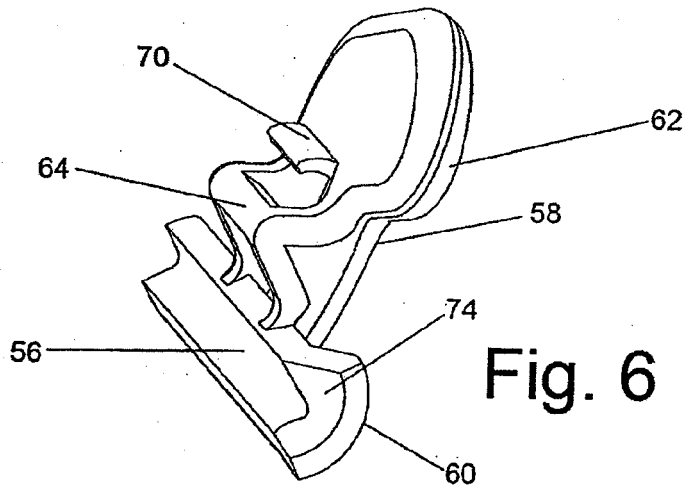
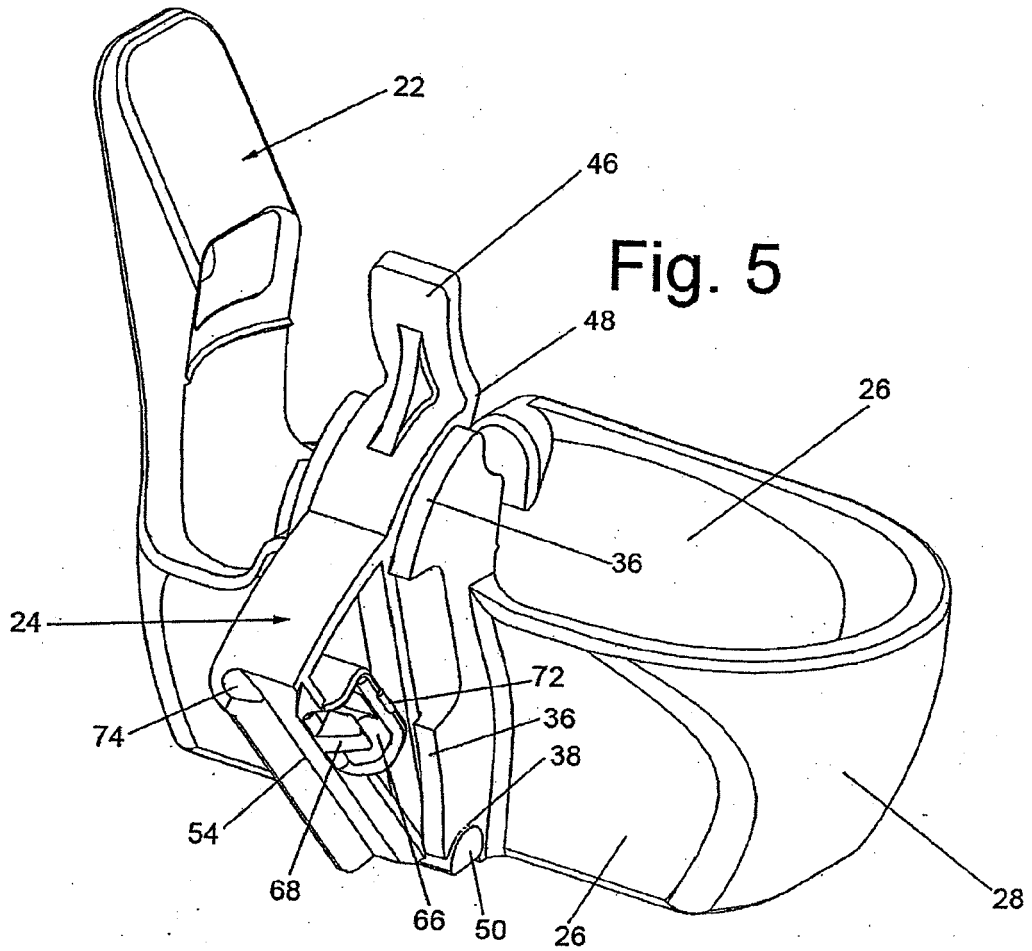

Fig. 7

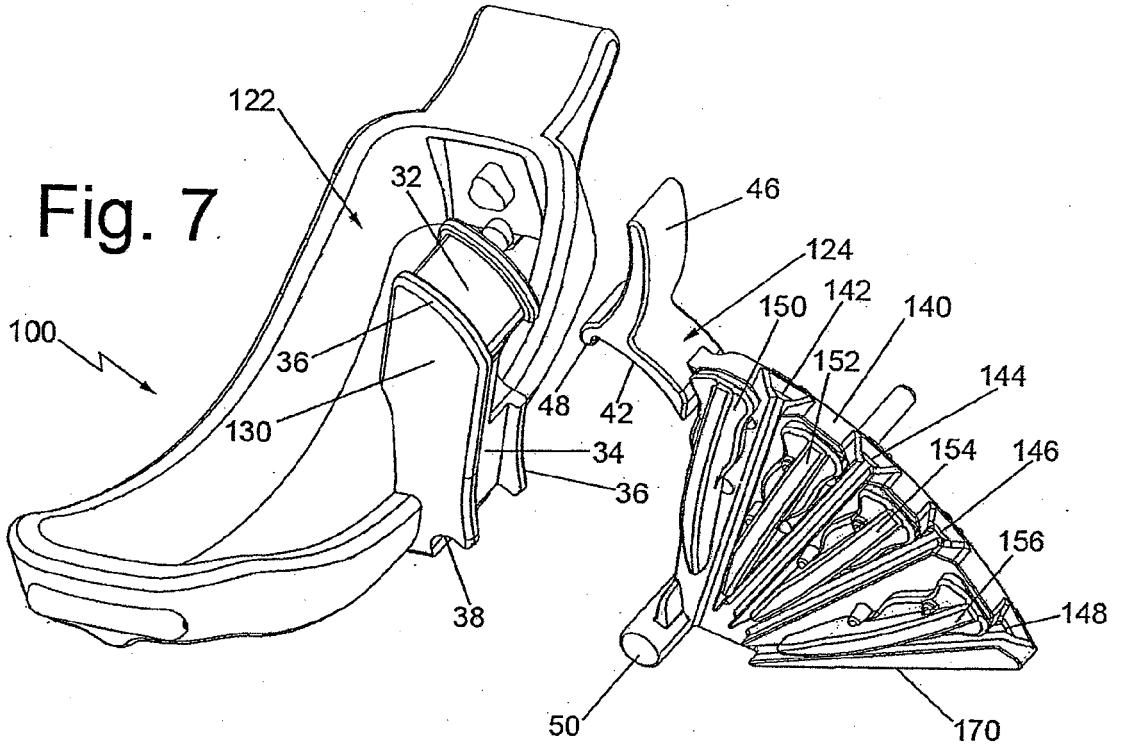

Fig. 8

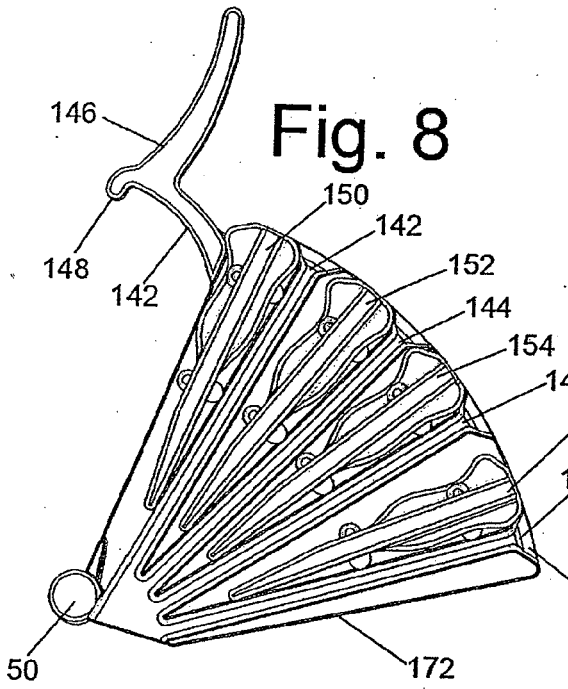
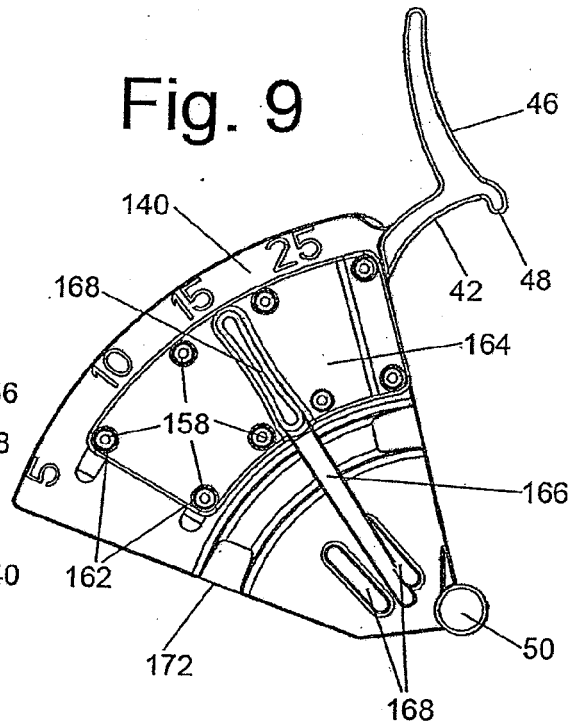

Fig. 9



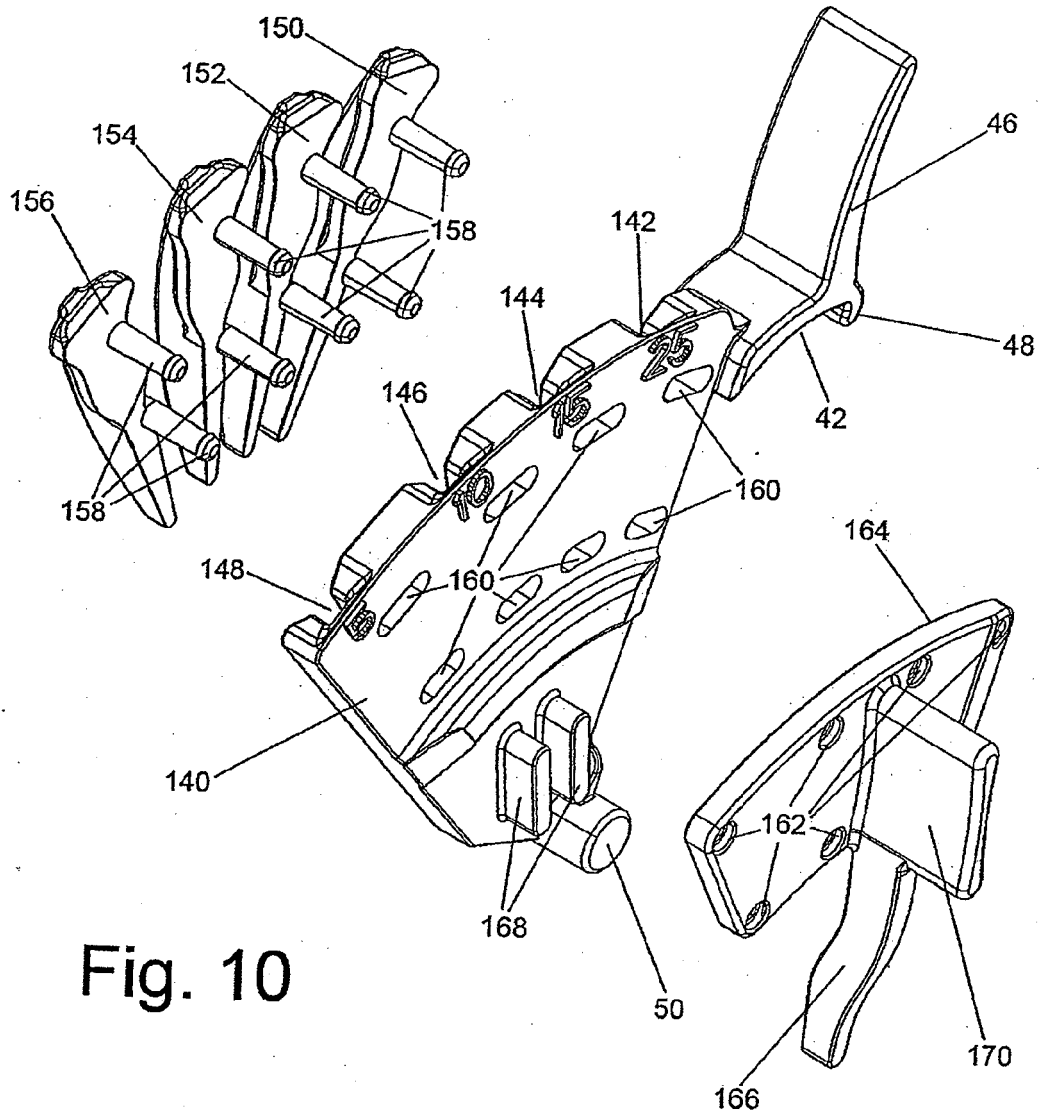

Fig. 10

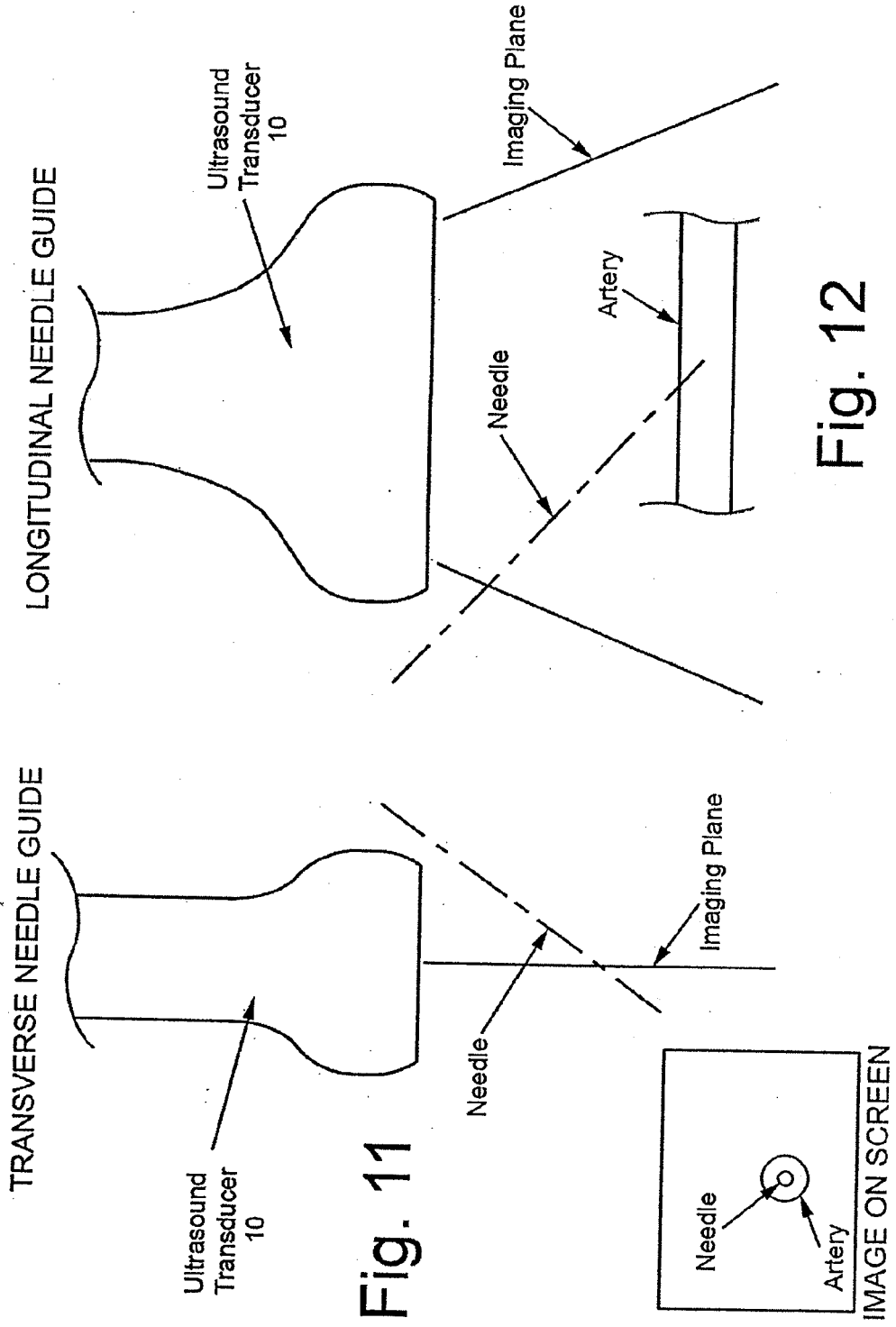

Fig. 11

Fig. 12

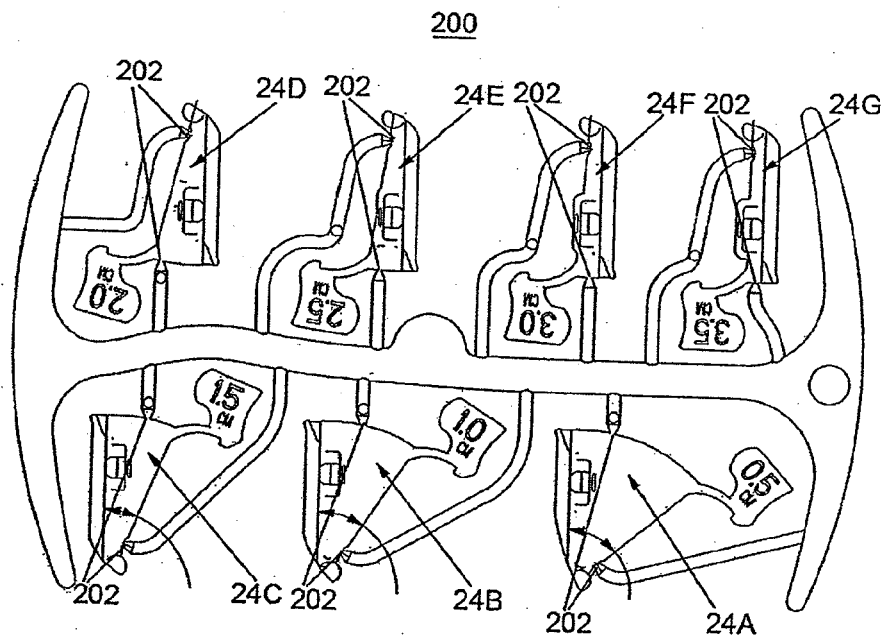

Fig. 13

REFERENCES CITED IN THE DESCRIPTION

This list of references cited by the applicant is for the reader's convenience only. It does not form part of the European patent document. Even though great care has been taken in compiling the references, errors or omissions cannot be excluded and the EPO disclaims all liability in this regard.

Patent documents cited in the description

- US 5052396 A, Wedel [0002]
- US 5076279 A, Arenson [0002]
- US 5623931 A, Wung [0002]
- US 5758650 A, Miller [0002]
- US 5941889 A, Cermak [0002]
- US 6379307 B, Filly [0002]
- US 7087024 B, Pruter [0002]
- US 6758817 B [0003]
- EP 1552792 A [0004]
- US 6361499 B [0005]

专利名称(译)	与超声换能器一起使用的针头引导系统可实现浅路径针头进入		
公开(公告)号	EP2219509B1	公开(公告)日	2019-10-16
申请号	EP2008856926	申请日	2008-12-02
申请(专利权)人(译)	CIVCO医疗器械CO., INC.		
当前申请(专利权)人(译)	CIVCO医疗器械CO., INC.		
[标]发明人	CERMAK CRAIG J CUMBERFORD BRENT A WILSON ROGER F WHITMORE WILLET F III		
发明人	CERMAK, CRAIG, J. CUMBERFORD, BRENT, A. WILSON, ROGER, F. WHITMORE, WILLET, F. III		
IPC分类号	A61B17/34 A61B1/00 A61B46/10 A61B8/08 A61B8/00 A61B90/00		
优先权	61/005316 2007-12-04 US 12/970797 2008-01-08 US		
其他公开文献	EP2219509A1		
外部链接	Espacenet		

摘要(译)

与超声换能器一起使用的超声针引导系统以及该引导系统的使用方法以提供用于各种深度的穿刺装置的可预测轨迹。导针器系统基本上由一个支架和一个导针器组成。支架布置成可释放地固定到超声换能器。然后将换能器/支架组件放入隔离的无菌盖中。针引导件被布置为容易地附接(例如,卡扣配合)到换能器/支架,并且盖插在它们之间。可以提供各种形式的针引导件,以用于相对于换能器的不同的穿刺装置尺寸和不同的进入角度。在一个实施例中,导针器布置成建立多个预定的进入角。

