



(11) **EP 1 860 459 B1**

(12) **EUROPEAN PATENT SPECIFICATION**

(45) Date of publication and mention of the grant of the patent:
28.07.2010 Bulletin 2010/30

(51) Int Cl.:
G01S 15/89 (2006.01) **G01S 7/52 (2006.01)**
A61B 8/00 (2006.01) **G10K 11/34 (2006.01)**

(21) Application number: **07010110.0**

(22) Date of filing: **22.05.2007**

(54) **Ultrasound diagnostic system and method for forming multiple receiving scan lines**

Ultraschalldiagnosesystem und Verfahren zur Bildung mehrerer empfangender Scan-Linien

Système et procédé de diagnostic à ultrason pour former plusieurs lignes de balayage de réception

(84) Designated Contracting States:
DE FR IT

(30) Priority: **23.05.2006 KR 20060046253**
17.11.2006 KR 20060114072

(43) Date of publication of application:
28.11.2007 Bulletin 2007/48

(73) Proprietor: **MEDISON CO., LTD.**
Kangwon-do 250-870 (KR)

(72) Inventors:
• **Bae, Moo Ho**
Seoul 138-240 (KR)
• **Daigle, Ronald E.**
Washington 98053 (US)

• **Ahn, Chi Young,**
Discusser & Medison Building
Seoul 135-280 (KR)
• **Yoon, Ra Young,**
Discusser & Medison Building
Seoul 135-280 (KR)

(74) Representative: **Lorenz, Werner**
Lorenz & Kollegen
Patentanwälte Partnerschaftsgesellschaft
Alte Ulmer Strasse 2
89522 Heidenheim (DE)

(56) References cited:
US-A- 6 042 547 **US-A1- 2001 051 772**
US-A1- 2002 082 500

EP 1 860 459 B1

Note: Within nine months of the publication of the mention of the grant of the European patent in the European Patent Bulletin, any person may give notice to the European Patent Office of opposition to that patent, in accordance with the Implementing Regulations. Notice of opposition shall not be deemed to have been filed until the opposition fee has been paid. (Art. 99(1) European Patent Convention).

Description

BACKGROUND

5 1. Field

[0001] The present invention generally relates to ultrasound diagnostic systems, and more particularly to an ultrasound diagnostic system and a method for forming multiple receiving scan lines.

10 2. Background

[0002] An ultrasound diagnostic system has become an important and popular diagnostic tool since it has a wide range of applications. Specifically, due to its non-invasive and non-destructive nature, the ultrasound diagnostic system has been extensively used in the medical profession. The ultrasound is transmitted to a target object through a probe equipped in the ultrasound diagnostic system. Ultrasound echoes from the target object reach the probe. The ultrasound echoes are converted into electrical receiving signals in analog-form. Ultrasound images are formed based on the electrical receiving signals obtained from the ultrasound echoes.

[0003] An ultrasound diagnostic system and method according to the preamble of claims 1 and 6 are known from US-A-6 042 547.

[0004] A higher frame rate and increased ultrasound transmission events can guarantee excellent ultrasound images. However, the frame rate is inversely proportional to the number of ultrasound transmission events. Therefore, the ultrasound image must be prevented from degrading, even if the number of ultrasound transmittance events is decreased.

[0005] In order to increase the frame rate under the same number of ultrasound transmission events, there exists a method of forming multiple receiving scan lines from one original receiving scan line. In this method, ultrasound outputted from the probe is focused on one transmittance scan line, wherein multiple receiving scan lines are simultaneously formed with ultrasound echoes from the scan line. That is, the multiple scan lines are formed with the ultrasound echoes generated by one transmission event.

[0006] In a conventional ultrasound diagnostic system, digital receiving signals are formed by converting the analog receiving signals at a constant extraction rate. Further, a receiving scan line is formed with the digital receiving signals. A time divisional method is used to form multiple scan lines at one time, and all the multiple scan lines should be configured within the same time allowed for single scan line. For an example, one scan line of triple scan lines should be configured within 1/3 time allowed for the single scan line, and therefore the amount of the data is limited in proportional to the allowed time.

[0007] If the conventional diagnostic system is designed to extract data at 60 MHz for configuring the single scan line, as the number of receiving scan lines is increased from single to dual, triple or quadruple receiving scan line, the extraction rate per one scan line of the multiple scan lines must be reduced from 60 MHz to 30 MHz, 20 MHz or 15 MHz, respectively. This means that the extraction rate of the single receiving signal is unnecessarily high and the ultrasound diagnostic system should process lots of useless data due to over-sampling. Further, when designing the conventional ultrasound diagnostic system, the change in extraction rates must be considered, which causes an increase in the costs of manufacturing the system.

BRIEF DESCRIPTION OF THE DRAWINGS

[0008] Arrangements and embodiments may be described in detail with reference to the following drawings in which like reference numerals refer to like probe elements and wherein:

FIG. 1 is a block diagram showing an ultrasound diagnostic system constructed in accordance with the present invention;

FIG. 2 is a schematic diagram showing a method of focusing an ultrasound transmission signal on a transmission scan line in accordance with the present invention;

FIG. 3 is a schematic diagram showing a method of forming receiving scan lines in accordance with the present invention;

FIG. 4 is a block diagram showing a receiving beam-former constructed in accordance with the present invention;

FIG. 5 is a schematic diagram showing the relations between probe elements, analog-digital converters, coarse delay units and first data storing units constructed in accordance with the present invention;

FIG. 6 is a schematic diagram illustrating the extraction and selection of data in accordance with the present invention; and

FIG. 7 is a schematic diagram showing a coarse delaying unit, first and second extracted data storing units and a

fine delaying and interpolating unit constructed in accordance with the present invention.

DETAILED DESCRIPTION

5 **[0009]** A detailed description may be provided with reference to the accompanying drawings. One of ordinary skill in the art may realize that the following description is illustrative only and is not in any way limiting. Other embodiments of the present invention may readily suggest themselves to such skilled persons having the benefit of this disclosure.

[0010] FIG. 1 is a block diagram showing an ultrasound diagnostic system constructed in accordance with the present invention. As shown in FIG. 1, the ultrasound diagnostic system 100 includes a probe 110, a transmission beam-former 120, a plurality of analog-digital converters (ADCs) 130, a receiving beam-former 140, a main storing unit 150, a digital signal processor (DSP) 160, a digital scan converter (DSC) 170 and a displaying unit 180.

10 **[0011]** The probe 110 includes a plurality of probe elements. Referring to FIG. 2, each probe element 111 converts electrical transmission signals into ultrasound transmission signals and transmits the ultrasound transmission signals to a focal point on a target object along a transmission scan line TL_n. The probe element also receives ultrasound echoes from the target object and converts the ultrasound echoes into electrical receive signals of analog-form. The number of probe elements participating in one transmission event and the number of probe elements receiving the ultrasound echoes generated by one event of transmission may depend on the design of the ultrasound diagnostic system 100 or the probe 110. Specifically, the number of probe elements (channels) required to form one original receiving scan line may vary according to the design of the ultrasound diagnostic system 100 or the probe 110. The analog receiving signals outputted from the probe 110 have a center frequency, which reflects the characteristics of the probe 110 and the internal tissues of the target object.

[0012] The transmission beam-former 120 forms a transmission beam, which is transmitted from the probe elements 111 to a transmission scan line TL_n, as shown in FIG. 2. When forming "m" numbers of receiving scan lines according to the method of forming "k"-multiple scan lines, "m/k" transmission scan lines are required, wherein "m" and "k" are positive integers. For instance, 256/4 transmission scan lines are required to form 256 receiving scan lines with the method of forming 4-multiple (quadruple) scan lines.

25 **[0013]** Referring to FIGS. 2 and 3, the ultrasound signals are transmitted from the probe elements 111 to one of the transmission scan lines TL₁, TL₂ ... TL_n. As shown in FIG. 3, the probe elements 111 receive the ultrasound echoes along one original receiving scan line R_n. Multiple scan lines (e.g., quadruple scan lines 4n-1, 4n-2, 4n-3 and 4n-4) are formed with the one original receiving scan line R_n. The original receiving scan line R_n may be disposed on the transmission scan line T_n.

[0014] The ADCs 130 form digital data from the analog receiving signals. The number of ADCs 130 is equal to that of the probe elements contributing to form one original receiving scan line (i.e., participating in the same transmission event). Further, the ADCs 130 correspond one-to-one with the probe elements 111. Each ADC samples the analog receiving signals, which are outputted from each probe element 111, at a predetermined sample rate and converts the analog receiving signals into the digital data. The predetermined sample rate may be 60 MHz.

35 **[0015]** The receiving beam-former 140 forms the data of multiple scan lines from the digital data outputted from the ADC 130. Specifically, the receiving beam-former 140 delays the digital data, extracts all of the delayed digital data at a rate of n-times of the center frequency of the analog receiving signals, and performs an interpolation with the extracted digital data to form the data of multiple receiving scan lines.

40 **[0016]** The data of multiple receiving scan lines are temporarily stored in the main storing unit 150. The main storing unit 150 may be configured with a register. The DSP 160 forms the image data to display the target object in B, C or D mode by processing the data inputted from the receiving beam-former 140 or the main storing unit 150. The DSC 170 scan-converts a scan-conversion to the image data. Further, the displaying unit 180 displays an ultrasound image with the scan-converted image data.

[0017] The receiving beam-former 140 is described below in detail. Referring to FIG. 4, the receiving beam-former 140 includes coarse delaying units 141, first data storing units 142, second data storing units 143, a fine delaying and interpolating unit 144 and a controlling unit 145.

45 **[0018]** The coarse delaying unit 141 may be configured with a plurality of dual-port random access memories (RAMs). The number of dual-port RAMs may be equal to the number of ADCs 130. Further, the dual-port RAMs correspond one-to-one with the ADCs 130, as shown in FIG. 5. The dual-port RAM includes a plurality of storing regions, a writing pointer WP, a reading pointer RP, a writing pin (not shown) and a reading pin (not shown). The data inputted through the writing pin are stored in the storing region pointed by the writing pointer WP. Also, the data stored in a storing region pointed by the reading pointer RP are outputted through the reading pin. All the writing and the reading pointers of the DPRs indicate the same storing region at an initial state when the digital data obtained from one transmission event has not been outputted from any of the ADCs 130. They begin to move among the storing regions at the same speed as the digital data are inputted. The reading pointer of each DPR is controlled in consideration of the distance differences between a specific point on the original receiving scan line R_n and the probe elements 111.

[0019] The digital data outputted from ADCs 130 are stored in the storing regions of the corresponding DPR one after another. For example, if five probe elements receive the ultrasound echoes generated by one event of the transmission, then the digital data outputted from each ADC and ADC1 to ADC5 are stored in each DPR and DPR1 to DPR5 at different times according to the delay profile (D-profile), as shown in FIG. 5. In another configuration, at a predetermined time from storing data in each region or from pointing each region with the writing pointer, the reading pointer may point the region under the control of the controlling unit 145. Therefore, the coarse delay unit 141 may output coarsely delayed data under the control of the controlling unit 145. To reduce the size of the coarse delaying unit 141 and to lower costs, the coarse delaying unit 141 may be configured with single DPR instead of the plurality of DPRs. In such a case, the digital data from each ADC are stored in different storing regions of the single DRP.

[0020] The first data storing units 142 store the coarsely delayed data outputted from the coarse delaying unit 141. The number of first data storing unit is also equal to that of the probe elements contributing to form one receiving scan line. Each first data storing unit 142 has a plurality of storing regions. Preferably, the first data storing unit 142 may be configured with the shift registers.

[0021] The second data storing units 143 store data extracted from the first storing unit 142 at a rate of n-times of the center frequency, wherein "n" denotes a positive integer. The second data storing unit 143 may be configured with a processing register, which also provides a plurality of storing regions. The number of second data storing unit is also equal to that of the probe elements contributing to form one receiving scan line. Further, the second data storing units 143 correspond one-to-one with the first data storing unit 142.

[0022] Information of the center frequency may be directly provided by a user such as a system designer or an operator. The ultrasound diagnostic system may further include a center frequency providing unit, which analyzes the analog receiving signals outputted from the probe elements and provides the information of the center frequency as a result of the analysis.

[0023] The controlling unit 145 extracts all of the delayed digital data from the first data storing unit 142 at a rate DR, which is defined as the following equation 1.

$$DR = n \times fc \dots\dots\dots(1)$$

In equation 1, "n" and "fc" denote a positive integer and the center frequency of the analog signals, respectively. For example, if the center frequency f_c is 5 MHz and n is 4, then the controlling unit 145 extracts the data stored in the first data storing unit 142 at a rate of 4-times of the center frequency, i.e., $4 \times 5 = 20MHz$, regardless of the number of receiving scan lines. As a further example, if the center frequency f_c is 2.5 MHz, then the controlling unit 145 extracts the data stored in the first data storing unit 142 at a rate of 4-times of the center frequency, i.e., at the rate of $4 \times 2.5 = 10MHz$, regardless of the number of receiving scan lines.

[0024] The controlling unit 145 also selects parts of the data in the second data storing unit 143 n-times of the center frequency in order to obtain interpolation data. The controlling unit 145 selects the data repeatedly as many as the number of multiple receiving scan lines formed with one original receiving scan line. The controlling unit 145 selects the data stored in the second data storing unit 143 at a rate CR, which is defined as the following equation 2.

$$CR = k \times n \times fc \dots\dots\dots(2)$$

In equation 2, "k" denotes the number of receiving scan lines to be obtained with one original receiving scan line, "n" denotes a positive integer and "fc" denotes the center frequency of the analog signals. For example, if the center frequency f_c is 5 MHz and it is designed to form triple receiving scan lines from one original receiving scan line, then the controlling unit 145 selects the data at a rate of 4-times of the center frequency and the number of multiple receiving scan lines at the rate of $3 \times 4 \times 5 = 60MHz$. Thus, the data selection for one receiving scan line of the triple scan lines performed at the rate of $60 \div 3 = 20MHz (= CR/k)$. As another example, if the center frequency f_c is 2.5 MHz and it is designed to form sextuple receiving scan lines with one original receiving scan line, then the controlling unit 145 selects the data at a rate of 4-times of the center frequency and the number of multiple receiving scan lines at the rate of $6 \times 4 \times 2.5 = 60MHz$. At this time, the data selection for one receiving scan line is performed at the rate of $60 \div 6 = 10MHz (= CR/k)$. Accordingly, the data selection for obtaining interpolation data can be selected at a constant rate, regardless of the number of receiving scan lines.

[0025] The number of selected data is equal to that of the receiving scan line to be formed with one original receiving

scan line. Referring to FIG. 6, the controlling 145 selects the data by moving a filter window four times to form quadruple receiving scan lines from one original receiving scan line. The filter window may have an 8-point size. In FIG. 6, "F1", "F2", "F3" and "F4" denote the movement of filter window, whereas "RS_i" denotes an output of i-th movement of the filter, i.e., "RS₁", "RS₂", "RS₃" and "RS₄" denote outputs of first, second, third and fourth movements of the filter, respectively.

[0026] The fine delaying and interpolating unit 144 performs a fine delay and interpolates the data of each receiving scan line, which is selected from the second data storing unit 143 at the rate of n-times of the center frequency and the multiple receiving scan lines under the control of the controlling unit 145. As shown in FIG. 7 the fine delaying and interpolating unit 144 includes a coefficient RAM 144a, a plurality of multipliers 144b and an adder 144c. The coefficient RAM 144a provides a look-up table of interpolation filter coefficients for the fine delay and the interpolation. The multipliers 144b correspond one-to-one with selected data and interpolation coefficient filters and multiply the filter coefficients to the selected data. The adder 144c adds the outputs of the multipliers 144b to form the interpolated data, which are to be used to form one receiving scan line among the multiple receiving scan lines. By interpolating the data extracted and selected at the rate of n-times of the center frequency, a finely delayed data can be obtained.

[0027] Although a gain controlling unit, which is used to form the receiving beam, is omitted in FIG. 4, it is natural that the receiving beam-former 140 includes the gain controlling unit to perform the basic function thereof.

[0028] As mentioned above, the data is extracted and selected at the rate of n-time of the center frequency in order to form the multiple receiving scan lines from one original receiving scan line. Therefore, lowering the extraction rate and the selection rate can be prevented, even though the number of receiving scan lines is increased.

Claims

1. An ultrasound diagnostic system (100) for forming multiple receiving scan lines with one original receiving scan line, comprising:

a plurality of probe elements (111) for changing ultrasound echoes from one original receiving scan line into analog signals, wherein the analog signals have a center frequency;
 an analog-digital converter (130) for converting the analog signals into digital data; and
 a receiving beam-former (140) for coarsely delaying the digital data, storing the coarsely delayed data, extracting all of the coarsely delayed data at a rate of DR, and forming data of multiple scan line by performing a fine delay and interpolation with the extracted data, the receiving beam-former (140) including:

coarse delaying units (141) for coarsely delaying the digital data inputted from the probe element (111);
 first storing units (142) for storing the coarsely delayed data inputted from each coarse delaying unit;
 second storing units (143) for storing data extracted from the first storing unit (142);
 a fine delaying and interpolating unit (144) for performing fine delay and interpolation to data selected from the second storing unit (143); and
 a controlling unit (145) for controlling the coarse delaying unit (141), the first and second storing units (142, 143), and the fine delaying and interpolating unit (144), extracting the data stored in the first storing unit (142) at the rate of DR defined as the following equation 1,

$$DR = n \times fc \dots\dots\dots(1),$$

wherein "n" is a katural number and "fc" denotes the center frequency, and selecting data stored in the second storing unit (143), repeatedly as many as the number of the multiple scan lines,

characterized in that

the controlling unit (145) selects the data stored in the second storing unit (143) at a rate of CR defined as the following equation 2,

$$CR = k \times n \times fc \dots\dots\dots(2),$$

wherein "k" denotes the number of the multiple receiving scan lines.

2. The system of Claim 1, wherein the numbers of the coarse delaying units (141), the first and second storing units (142,143) are equal to the number of the probe elements (111) contributing to form the one original receiving scan line, and wherein the first and second storing units (142,143) correspond one-to-one with the probe elements (111).

5 3. The system of Claim 1, wherein the controlling unit (145) selects the data by moving a filter having a predetermined size repeatedly as many as the number of the multiple receiving scan lines (144).

4. The system of Claim 1, wherein the fine delaying and interpolating unit (144) includes:

10 a coefficient RAM (144a) for providing a look-up table of filter coefficients for the fine delay and the interpolation unit (144);
 a plurality of multipliers (144b) for multiplying the filter coefficients to the selected data; and
 an adder (144c) for adding outputs of the multipliers.

15 5. The system of Claim 4, further comprising:

a main storing unit (150) for storing the data of the multiple receiving scan lines;
 a scan converting unit for scan-converting the data of the multiple receiving scan lines; and
 a displaying unit for displaying ultrasound images with the scan-converted data.

20

6. A method of forming multiple receiving scan lines with one original receiving scan line, comprising:

changing ultrasound signals reflected from one original receiving scan line into analog signals, wherein the analog signals have a center frequency;
 25 converting the analog signals into digital data;
 coarsely delaying the digital data;
 storing the coarsely delayed data;
 extracting all of the coarsely delayed data at a rate of DR defined as the following equation 1,

30

$$DR = n \times fc \dots\dots\dots(1),$$

wherein "n" is a natural number and "fc" denotes the center frequency,
 forming multiple scan lines with the extracted data,

35

characterized by

selecting extracted data, repeatedly as many as the number of the multiple scan links, at a rate of CR defined as the following equation 2,

40

$$CR = k \times n \times fc \dots\dots\dots(2),$$

wherein "k" denotes the number of the multiple receiving scan lines.

45

7. The method of Claim 6, wherein the step of forming the multiple scan lines includes:

storing the extracted data;
 selecting a part of the stored extracted data, and
 50 performing fine delay and interpolation to the selected data.

8. The method of Claim 6, wherein a part of the extracted data is selected by moving a filter having a predetermined size repeatedly as many as the number of the multiple receiving scan lines.

55

Patentansprüche

1. Ultraschalldiagnosesystem (100) zur Bildung mehrerer empfangener Scanlinien mit einer ursprünglichen empfan-

genen Scanlinie, welches Folgendes aufweist:

eine Vielzahl von Messsondenelementen (111) zum Umwandeln von Ultraschallechos von einer ursprünglichen empfangenen Scanlinie in analoge Signale,
 wobei die analogen Signale eine Mittenfrequenz aufweisen;
 einen Analog-Digital-Konverter (130) zum Konvertieren der analogen Signale in digitale Daten; und
 einen Empfangsstrahlformer (140) zum groben Verzögern der digitalen Daten, Speichern der grob verzögerten Daten, Extrahieren sämtlicher der grob verzögerten Daten mit einer Geschwindigkeit von DR und Bilden von Daten aus mehreren Scanlinien mittels Durchführen einer feinen Verzögerung und Interpolation mit den extrahierten Daten, wobei der Empfangsstrahlformer (140) Folgendes aufweist:

Grobverzögerungseinheiten (141) zum groben Verzögern der von dem Messsondenelement (111) eingegebenen digitalen Daten;
 erste Speichereinheiten (142) zum Speichern der grob verzögerten, von jeder Grobverzögerungseinheit eingegebenen Daten;
 zweite Speichereinheiten (143) zum Speichern der von der ersten Speichereinheit (142) extrahierten Daten;
 eine Fein-Verzögerungs- und Interpolationseinheit (144) zur Durchführung einer feinen Verzögerung und Interpolation von Daten, die von der zweiten Speichereinheit (143) ausgewählt wurden; und
 eine Steuereinheit (145) zum Steuern der Grobverzögerungseinheit (141), der ersten und zweiten Speichereinheiten (142,143) und der Fein-Verzögerungs- und Interpolationseinheit (144), zum Extrahieren der in der ersten Speichereinheit (142) gespeicherten Daten mit der durch die folgende Gleichung 1 definierten Geschwindigkeit DR,

$$DR = n \times fc \dots\dots\dots (1)$$

wobei "n" eine natürliche Zahl ist und "fc" die Mittenfrequenz bezeichnet,
 und zum wiederholten Auswählen von in der zweiten Speichereinheit (143) gespeicherten Daten der Anzahl der mehreren Scanlinien entsprechend,
dadurch gekennzeichnet, dass die Steuereinheit (145) die in der zweiten Speichereinheit (143) gespeicherten Daten mit einer durch die folgende Gleichung 2 definierten Geschwindigkeit CR auswählt,

$$CR = k \times n \times fc \dots\dots\dots (2)$$

wobei "k" die Anzahl der mehrfachen empfangenen Scanlinien bezeichnet.

2. System nach Anspruch 1, wobei die Anzahl der Grobverzögerungseinheiten (141), der ersten und zweiten Speichereinheiten (142,143) der Anzahl der Messsondenelemente (111) entspricht, welche dazu beitragen, die eine ursprünglich empfangene Scanlinie zu bilden, und wobei die ersten und zweiten Speichereinheiten (142,143) einzu-eins den Messsondenelementen (111) entsprechen.
3. System nach Anspruch 1, wobei die Steuereinheit (145) die Daten durch mehrfaches Bewegen eines Filters mit einer vorbestimmten Größe der Anzahl der mehreren empfangenen Scanlinien (144) entsprechend auswählt.
4. System nach Anspruch 1, wobei die Fein-Verzögerungs- und Interpolationseinheit (144) Folgendes aufweist:
 - ein Koeffizienten-RAM (144a) zum Bereitstellen einer Nachschlagetabelle von Filterkoeffizienten für die Fein-Verzögerungs- und Interpolationseinheit (144);
 - eine Mehrzahl von Multiplizierern (144b) zum Multiplizieren der Filterkoeffizienten mit den ausgewählten Daten; und
 - einen Addierer (144c) zum Addieren von Ausgaben der Multiplizierer.
5. System nach Anspruch 4, welches des weiteren Folgendes aufweist:

eine Hauptspeichereinheit (150) zum Speichern der Daten der mehreren empfangenen Scanlinien;

EP 1 860 459 B1

eine Scankonversionseinheit zum Scankonvertieren der Daten der mehreren empfangenen Scanlinien; und eine Anzeigeeinheit zum Anzeigen von Ultraschallbildern mit den scankonvertierten Daten.

- 5 6. Verfahren zur Bildung mehrerer empfangener Scanlinien mit einer ursprünglichen empfangenen Scanlinie, welches Folgendes aufweist:

Umwandeln von von einer ursprünglichen empfangenen Scanlinie reflektierten Ultraschallsignalen in analoge Signale, wobei die analogen Signale eine Mittenfrequenz aufweisen;
10 Konvertieren der analogen Signale in digitale Daten;
Grobverzögern der digitalen Daten;
Speichern der grob verzögerten Daten;
Extrahieren aller grob verzögerten Daten mit einer durch die folgende Gleichung 1 definierten Geschwindigkeit;

$$15 \quad DR = n \times fc \dots\dots\dots (1),$$

wobei "n" eine natürliche Zahl ist und "fc" die Mittenfrequenz bezeichnet,
20 Bilden von mehreren Scanlinien mit den extrahierten Daten,
mehrfaches Auswählen der extrahierten Daten entsprechend der Anzahl der mehrfachen Scanlinien,
mit einer durch die folgende Gleichung 2 definierten Geschwindigkeit CR,

$$25 \quad CR = k \times n \times fc \dots\dots\dots (2),$$

wobei "k" die Anzahl der mehrfachen empfangenen Scanlinien bezeichnet.

7. Verfahren nach Anspruch 6, wobei der Schritt des Bildens der mehreren Scanlinien Folgendes aufweist:

30 Speichern der extrahierten Daten;
Auswählen eines Teils der gespeicherten extrahierten Daten; und
Durchführen einer feinen Verzögerung und Interpolation der ausgewählten Daten.

- 35 8. Verfahren nach Anspruch 6, wobei ein Teil der extrahierten Daten durch Bewegen eines Filters, welcher eine vorbestimmte Größe aufweist, mehrfach entsprechend der Anzahl der mehreren empfangenen Scanlinien ausgewählt wird.

40 **Revendications**

1. Système de diagnostic à ultrasons (100) destiné à former des lignes de balayage de réception multiples comportant une ligne de balayage de réception originale, comprenant :

45 une pluralité d'éléments formant sondes (111) destinés à transformer des échos ultrasonores provenant d'une ligne de balayage de réception originale en signaux analogiques, les signaux analogiques ayant une fréquence centrale ;
un convertisseur analogique-numérique (130) destiné à convertir les signaux analogiques en données numériques, et
50 un formateur de faisceau de réception (140) destiné à temporiser approximativement les données numériques, à stocker les données temporisées approximativement, à extraire toutes les données temporisées approximativement à une cadence de DR, et à former des données de lignes de balayage multiples en effectuant une temporisation fine et une interpolation avec les données extraites, le formateur de faisceau de réception (140) comprenant :

55 des unités de temporisation approximative (141) destinées à temporiser approximativement les données numériques entrées en provenance de l'élément formant sonde (111) ;
des premières unités de stockage (142) destinées à stocker les données temporisées approximativement

EP 1 860 459 B1

entrées en provenance de chaque unité de temporisation approximative ;
des secondes unités de stockage (143) destinées à stocker des données extraites de la première unité de
stockage (142) :

5 une unité de temporisation fine et d'interpolation (144) destinée à effectuer une temporisation fine et une inter-
polation de données sélectionnées dans la seconde unité de stockage (143) ; et
une unité de commande (145) destinée à commander l'unité de temporisation approximative (141), les première
et seconde unités de stockage (142, 143) et l'unité de temporisation fine et d'interpolation (144), à extraire les
10 données stockées dans la première unité de stockage (142) à la cadence de DR définie par l'équation 1 suivante :

$$DR = n \times fc \dots \dots \dots (1)$$

15 répétitivement un nombre de fois égal au nombre des lignes de balayage multiples, et à sélectionner des
données stockées dans la seconde unité de stockage (143) répétitivement un nombre de fois égal au nombre
des lignes de balayage multiples,

caractérisé en ce que

l'unité de commande (145) sélectionne les données stockées dans la seconde unité de stockage (143) à une
cadence de CR définie par l'équation 2 suivante

20

$$CR = k \times n \times fc \dots \dots \dots (2)$$

25 répétitivement un nombre de fois égal au nombre des lignes de balayage multiples
où "k" désigne le nombre de lignes de balayage de réception multiples.

2. Système selon la revendication 1, dans lequel les nombres des unités de temporisation approximative (141), des
première et secondes unités de stockage (142, 143) sont égaux au nombre des éléments formant sonde (111)
30 contribuant à former la ligne de balayage de réception originale, et dans lequel les première et seconde unités de
stockage (142, 143) correspondent respectivement aux éléments formant sonde.

3. Système selon la revendication 1, dans lequel l'unité de commande (145) sélectionne les données en déplaçant
un filtre ayant des dimensions prédéterminées répétitivement un nombre de fois égal au nombre des lignes de
35 balayage de réception multiples (144).

4. Système selon la revendication 1, dans lequel l'unité de temporisation fine et d'interpolation (144) comprend :

une RAM de coefficients (144a) destinée à fournir une table de correspondance de coefficients de filtre pour
40 l'unité de temporisation fine d'interpolation (144) ;
une pluralité de multiplicateurs (144b) destinés à multiplier les coefficients de filtre pour les données
sélectionnées ; et
un additionneur (144c) destiné à additionner les sorties des multiplicateurs.

5. Système selon la revendication 4, comprenant en outre :

une unité de stockage principale (150) destinée à stocker les données des lignes de balayage de réception
multiples ;
une unité de conversion par balayage destinée à convertir par balayage les données des lignes de balayage
50 de réception multiples ; et
une unité d'affichage destinée à afficher des images ultrasonores avec les données converties par balayage.

6. Procédé de formation de lignes de balayage de réception multiples comportant une ligne de balayage de réception
originale, comprenant:

55

la transformation des signaux ultrasonores réfléchis en provenance d'une ligne de balayage de réception ori-
ginale en signaux analogiques, les signaux analogiques ayant une fréquence centrale ;

EP 1 860 459 B1

la conversion des signaux analogiques en données numériques ;
la temporisation approximative des données numériques ;
le stockage des données numériques temporisées approximativement ;
l'extraction de toutes les données temporisées approximativement à une cadence de DR définie par l'équation
1 suivante :

$$DR = n \times fc \dots\dots\dots(1)$$

où "n" est un nombre naturel et "fc" désigne la fréquence centrale,
la formation de lignes de balayage multiples avec les données extraites,
caractérisé par
la sélection de données extraites répétitivement un nombre de fois égal au nombre des lignes de balayage
multiples à une cadence de CR définie par l'équation 2 suivante

$$CR = k \times n \times fc \dots\dots\dots(2),$$

où "k" désigne le nombre des lignes de balayage de réception multiples.

7. Procédé selon la revendication 6, dans lequel l'étape de formation des lignes de balayage multiples comprend :

le stockage les données extraites ;
la sélection d'une partie des données stockées extraites, et
la temporisation fine et une interpolation sur les données sélectionnées.

8. Procédé selon la revendication 6, dans lequel une partie des données extraites est sélectionnée en déplaçant un
filtre ayant une taille prédéterminée répétitivement un nombre de fois égal au nombre des lignes de balayage de
réception multiples.

FIG. 1

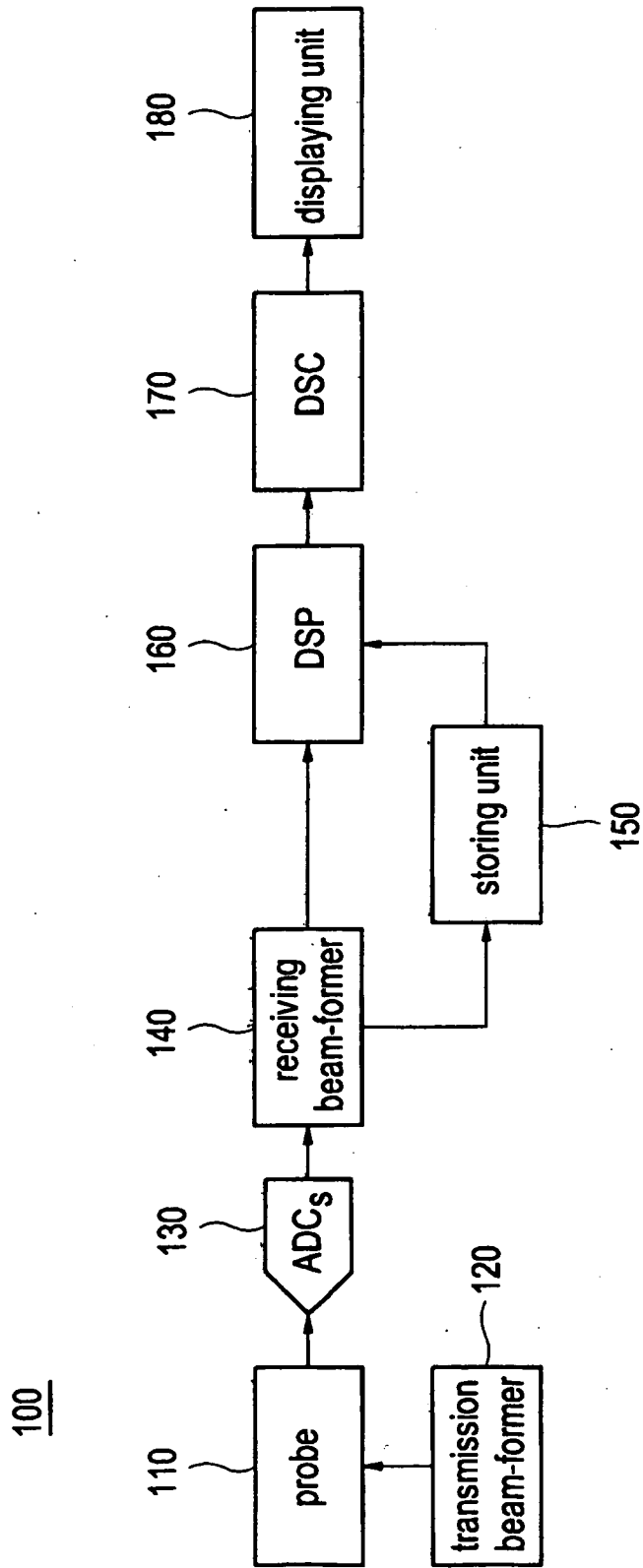

FIG. 2

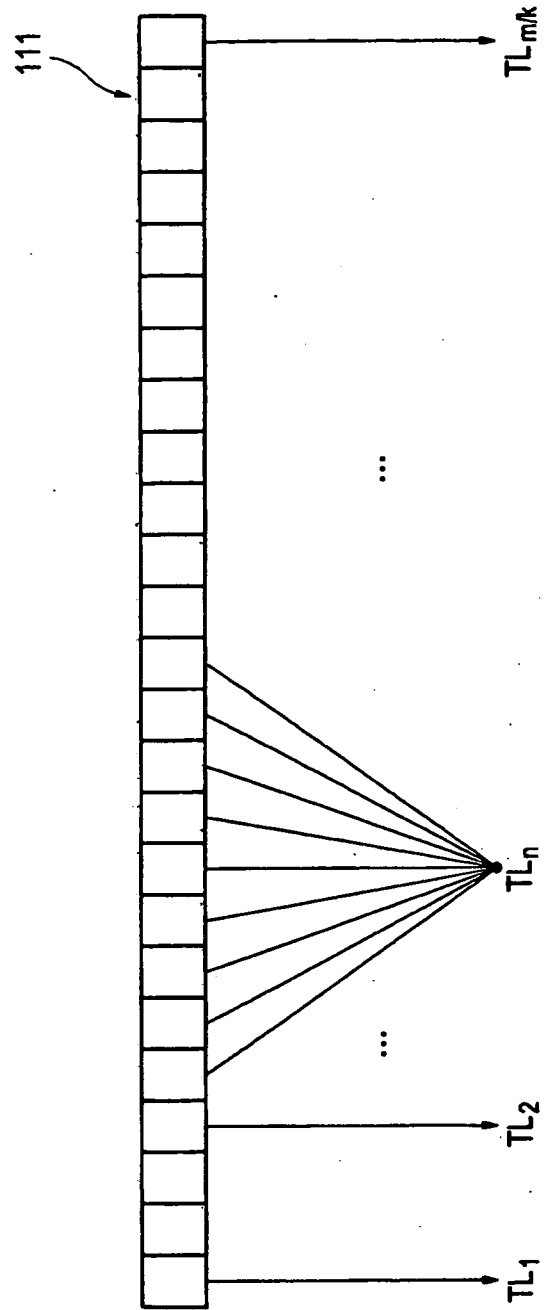

FIG. 3

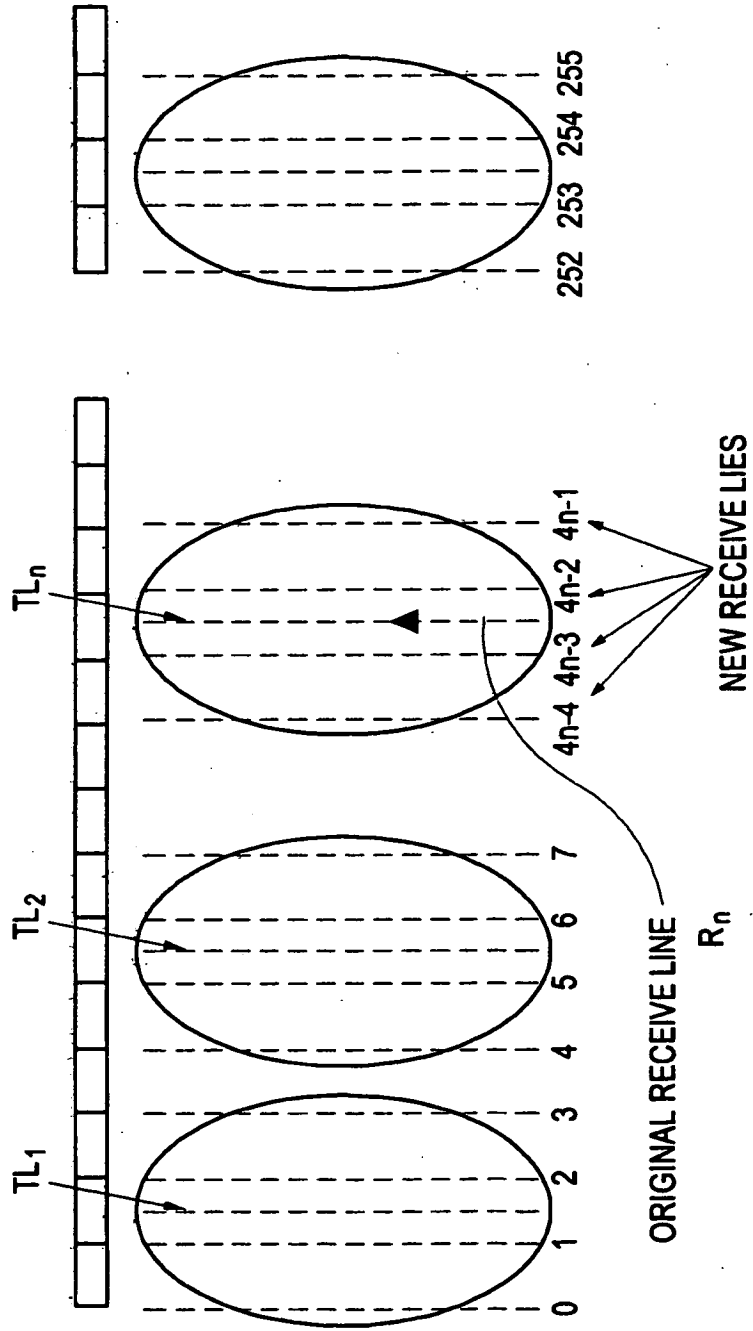

FIG. 4

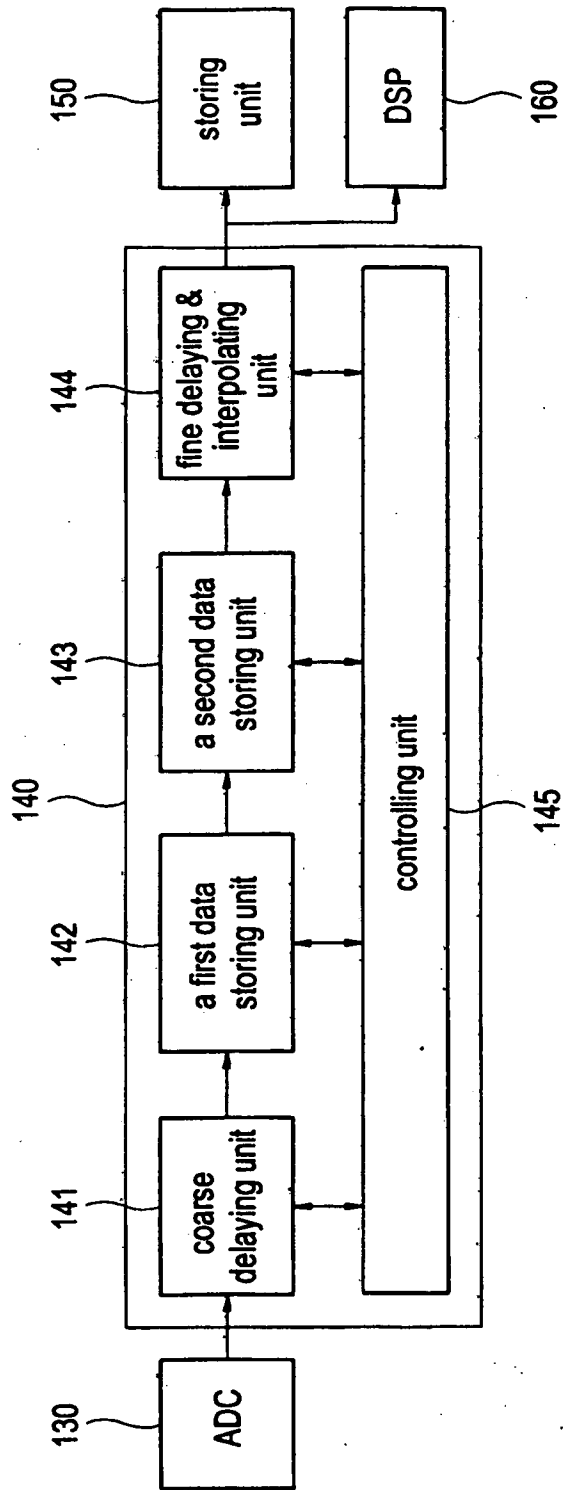

FIG. 5

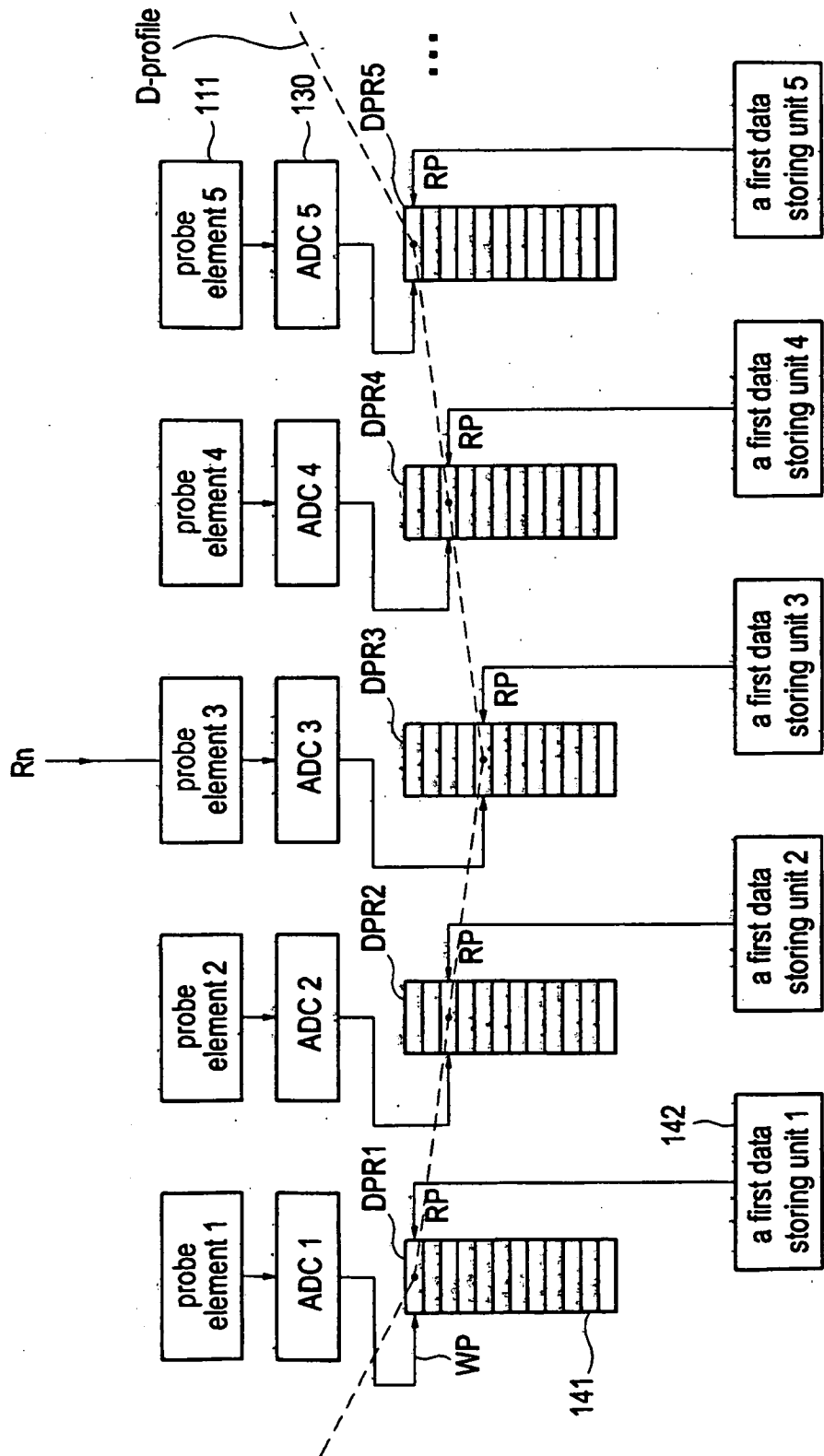

FIG. 6

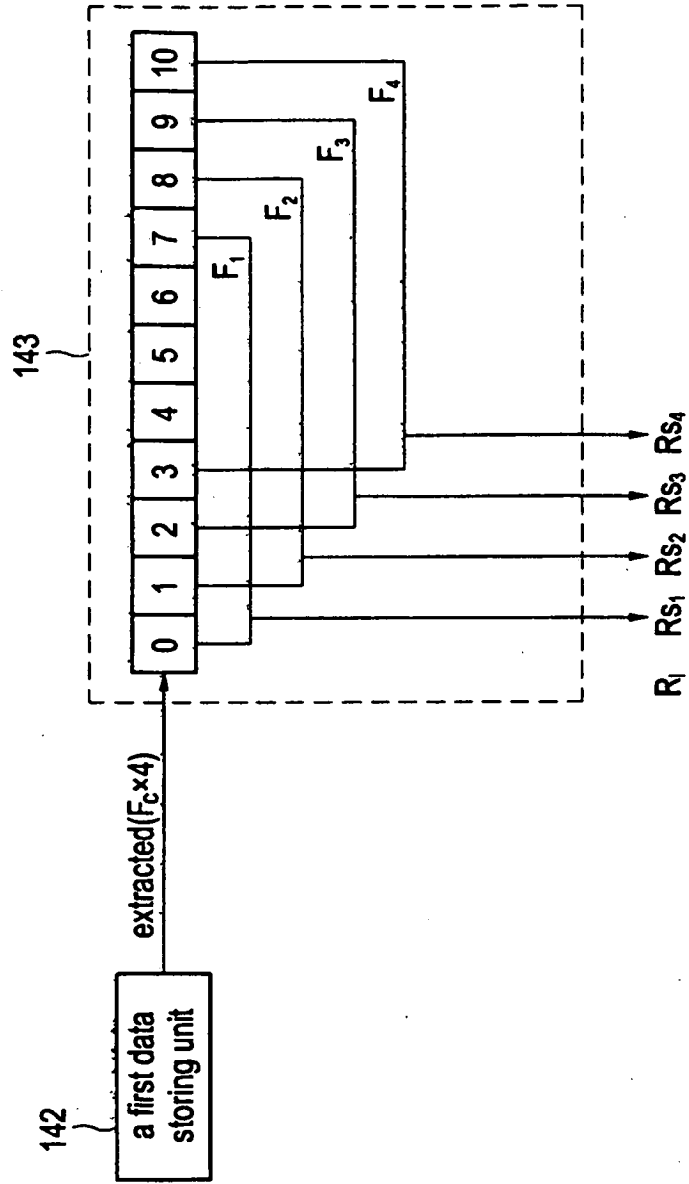
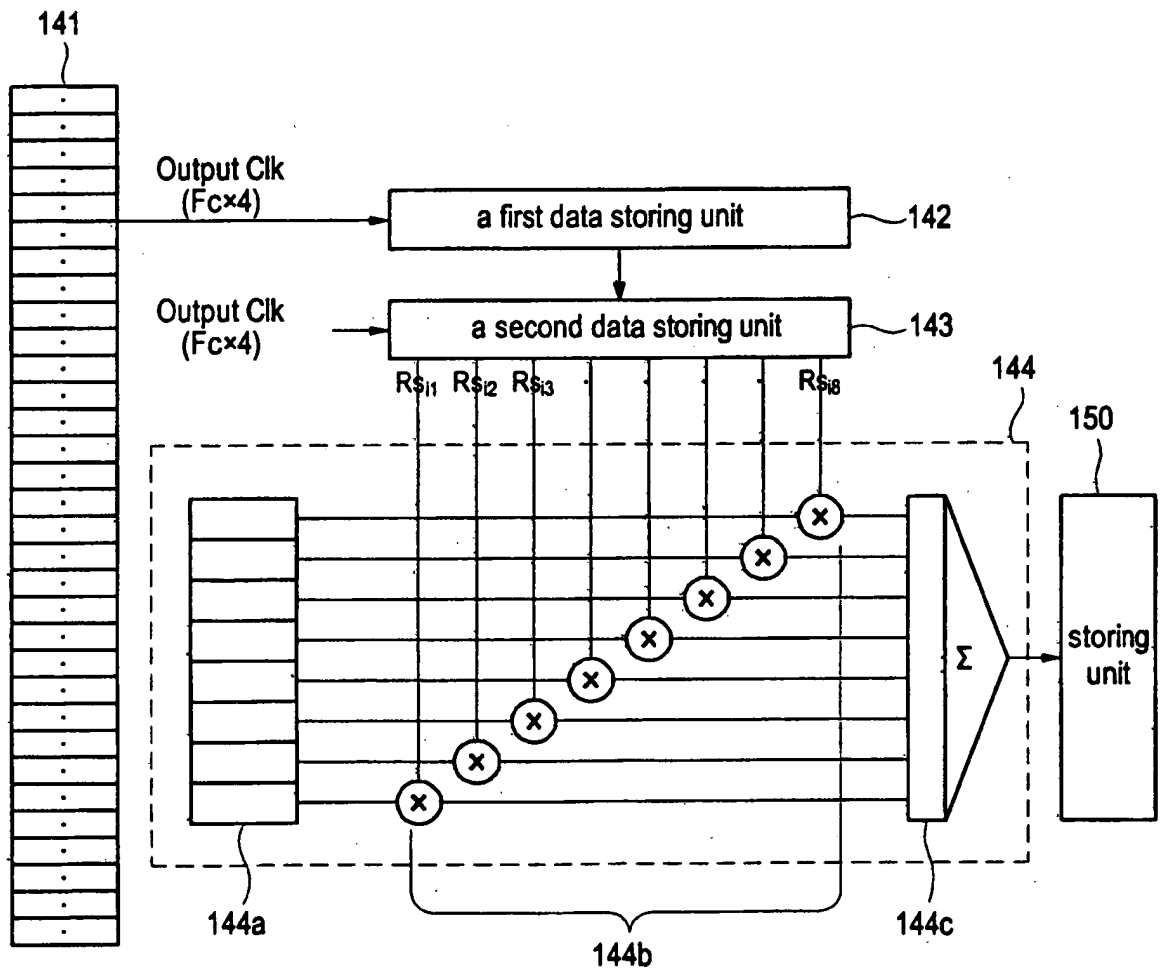

FIG. 7



REFERENCES CITED IN THE DESCRIPTION

This list of references cited by the applicant is for the reader's convenience only. It does not form part of the European patent document. Even though great care has been taken in compiling the references, errors or omissions cannot be excluded and the EPO disclaims all liability in this regard.

Patent documents cited in the description

- US 6042547 A [0003]

专利名称(译)	超声诊断系统和形成多个接收扫描线的方法		
公开(公告)号	EP1860459B1	公开(公告)日	2010-07-28
申请号	EP2007010110	申请日	2007-05-22
申请(专利权)人(译)	MEDISON CO. , LTD.		
当前申请(专利权)人(译)	MEDISON CO. , LTD.		
[标]发明人	BAE MOO HO DAIGLE RONALD E		
发明人	BAE, MOO HO DAIGLE, RONALD E. AHN, CHI YOUNG, DISCUSSE & MEDISON BUILDING YOON, RA YOUNG, DISCUSSE & MEDISON BUILDING		
IPC分类号	G01S15/89 G01S7/52 A61B8/00 G10K11/34		
CPC分类号	A61B8/00 G01S7/52028 G01S7/52034 G01S7/52095		
代理机构(译)	LORENZ , WERNER		
优先权	1020060046253 2006-05-23 KR 1020060114072 2006-11-17 KR		
其他公开文献	EP1860459A1		
外部链接	Espacenet		

摘要(译)

本发明的实施例可以提供用于从一个原始接收扫描线形成多个接收扫描线的超声成像系统和方法。从一个原始接收扫描线反射的超声信号被转换成具有中心频率的模拟信号。模拟信号被转换成数字数据。粗略地延迟数字数据，其中以中心频率的n倍的速率提取粗略延迟的数据。通过执行精细延迟和内插来形成多个接收扫描线的数据。对于插值，以中心频率的n倍和多个接收扫描线的速率选择提取数据的一部分。

