



(11) **EP 1 079 242 B1**

(12) **EUROPEAN PATENT SPECIFICATION**

(45) Date of publication and mention of the grant of the patent:
22.08.2007 Bulletin 2007/34

(51) Int Cl.:
G01S 15/58 (2006.01) A61B 8/08 (2006.01)
G01S 15/89 (2006.01)

(21) Application number: **00113591.2**

(22) Date of filing: **27.06.2000**

(54) **Ultrasound diagnostic apparatus**

Ultraschalldiagnosegerät

Appareil diagnostique à ultrasons

(84) Designated Contracting States:
DE FR GB

(30) Priority: **24.08.1999 JP 23743399**

(43) Date of publication of application:
28.02.2001 Bulletin 2001/09

(73) Proprietor: **MATSUSHITA ELECTRIC INDUSTRIAL CO., LTD**
Kadoma-shi, Osaka 571-8501 (JP)

(72) Inventors:
• **Sunagawa, Kazuhiro**
Sendai-shi,
Miyagi-ken 989-3204 (JP)

- **Tannaka, Yoshinao**
Aiko-gun,
Kanagawa-ken 243-0301 (JP)
- **Kanai, Hiroshi**
Sendai-shi,
Miyagi-ken 981-0933 (JP)

(74) Representative: **Manitz, Finsterwald & Partner GbR**
Postfach 31 02 20
80102 München (DE)

(56) References cited:
EP-A- 0 311 431 US-A- 4 972 838
US-A- 5 551 434 US-A- 5 615 680
US-A- 5 910 119

EP 1 079 242 B1

Note: Within nine months from the publication of the mention of the grant of the European patent, any person may give notice to the European Patent Office of opposition to the European patent granted. Notice of opposition shall be filed in a written reasoned statement. It shall not be deemed to have been filed until the opposition fee has been paid. (Art. 99(1) European Patent Convention).

DescriptionBACKGROUND OF THE INVENTION5 Field of the Invention

[0001] This invention relates to an ultrasound diagnostic apparatus designed to detect the velocity of an organ or a tissue in a body.

10 Description of the Related Art

[0002] General-purpose ultrasound diagnostic apparatuses can operate in any one of different modes such as a B mode, an M mode, an FFT Doppler mode, and a color Doppler mode. In some cases, a diagnosis on arteriosclerosis is based on an ultrasound diagnosis on a carotid artery which uses a general-purpose ultrasound diagnostic apparatus. Specifically, the ultrasound diagnosis is implemented by using shape information generated by the B mode and the M mode of operation of the apparatus, and blood velocity information provided by the FFT Doppler mode or the color Doppler mode of operation of the apparatus.

[0003] When the general-purpose ultrasound diagnostic apparatus operates in the B mode, the inside diameter of a blood vessel, the thickness of a blood vessel wall, and the conditions of a morbid protuberance can be evaluated from information provided by the apparatus. When the general-purpose ultrasound diagnostic apparatus operates in the M mode, a time-domain change of a blood vessel diameter in response to a heartbeat can be evaluated from information provided by the apparatus. When the general-purpose ultrasound diagnostic apparatus operates in the FFT Doppler mode or the color Doppler mode, the rate of a blood flow in a blood-vessel strangulated portion caused by a morbid protuberance can be evaluated from information provided by the apparatus.

[0004] As previously mentioned, the conditions of a morbid protuberance can be evaluated by using the B mode of operation of the general-purpose ultrasound diagnostic apparatus. Specifically, the presence and the size of the morbid protuberance are observed via the apparatus. In addition, the brightnesses in an ultrasound-echo-based image (a B mode image or a sectional image) displayed on a monitor of the apparatus are observed. The conditions of the morbid protuberance are judged from the size information and the brightness information.

[0005] Generally, a morbid protuberance caused by a thrombus is indicated as an image portion having a low brightness. Therefore, in some cases, such a morbid protuberance fails to be found by using the B mode of operation of the general-purpose ultrasound diagnostic apparatus.

[0006] As previously mentioned, the conditions of a morbid protuberance are judged from size information and brightness information during the B mode of operation of the general-purpose ultrasound diagnostic apparatus. Since the brightness information is used, it is difficult to quantitatively evaluate the conditions of the morbid protuberance.

[0007] Japanese published unexamined patent application 9-313485 discloses an ultrasound apparatus for diagnosing the conditions of a tissue in a body which uses tissue Doppler imaging. The apparatus in Japanese application 9-313485 measures motion of the tissue relative to an ultrasound probe. Accordingly, it is difficult for the apparatus to detect a self-motionless suspended portion in a moving tissue. In addition, it is difficult for the apparatus to detect motion of a tissue in a direction perpendicular to an ultrasound beam.

[0008] Japanese published unexamined patent application 10-5226 discloses an ultrasound apparatus for diagnosing the conditions of a tissue in a body. In the apparatus of Japanese application 10-5226, information is generated which represents the amplitude and the phase of an electric signal resulting from detection of ultrasound echoes. Then, the instantaneous position of an object is decided on the basis of the amplitude and phase information in a least-squares method. Accurate tracking on the object is implemented in response to the decided instantaneous position thereof. The accurate tracking makes it possible for the apparatus to correctly detect self-motion of a portion in a tissue which is being greatly moved by a heartbeat.

[0009] The apparatus of Japanese application 9-313485 and the apparatus of Japanese application 10-5226 can detect only a component of the velocity of an object in a direction along the acoustic line of an ultrasound beam.

[0010] Some ultrasound diagnostic apparatuses for measuring a blood flow rate are equipped with arrangements which implement correction related to the angle between the direction of a blood vessel and the direction of the acoustic line of an ultrasound beam. This correction method can not be applied to detection of the velocity of an organ or a tissue which is moving in various directions.

[0011] US 5,910,119 relates to a system for performing ultrasonic color Doppler imaging to produce absolute mean velocity and flow direction information for complex media, including soft biological tissue. Two conventional ultrasonic color Doppler beams are steered at two different angles such that sampling is performed at the point of intersection between the two differently-steered color Doppler beams. The absolute mean velocity and direction of flow or motion of acoustic reflectors is computed from the frequency-shift information at the sample volumes.

SUMMARY OF THE INVENTION

5 [0012] It is an object of this invention to provide an ultrasound diagnostic apparatus which can measure the direction of motion of a tissue (or an organ) in a body, the velocity of the tissue, and the distance traveled by the tissue regardless of the angular difference between the direction of motion of the tissue and the direction of the acoustic line of an ultrasound beam.

[0013] A first aspect of this invention provides an ultrasound diagnostic apparatus according to claim 1.

10 [0014] A second aspect of this invention is based on the first aspect thereof, and provides an ultrasound diagnostic apparatus wherein the ultrasound probe includes transducer elements, and further comprising means for selecting ones from among the transducer elements as active elements in response to a depth of a measured portion of the tissue from a surface of the body.

15 [0015] A third aspect of this invention is based on the first aspect thereof, and provides an ultrasound diagnostic apparatus wherein the delay controlling means comprises means for changing the acoustic line direction of transmission and reception of the ultrasound pulse beam and the ultrasound echo beam in response to a depth of a measured portion of the tissue from a surface of the body.

20 [0016] A fourth aspect of this invention is based on the first aspect thereof, and provides an ultrasound diagnostic apparatus wherein the delay controlling means comprises means for changing the acoustic line direction of transmission and reception of the ultrasound pulse beam and the ultrasound echo beam among a plurality of different directions with respect to the tissue, and the tissue velocity calculating means comprises means for calculating a velocity of the tissue in a direction perpendicular to a front surface of the ultrasound probe, a distance traveled by the tissue in the direction perpendicular to the front surface of the ultrasound probe, a velocity of the tissue in a direction parallel to the front surface of the ultrasound probe, and a distance traveled by the tissue in the direction parallel to the front surface of the ultrasound probe from the phase-detection result signal.

25 [0017] A fifth aspect of this invention is based on the first aspect thereof, and provides an ultrasound diagnostic apparatus wherein the delay controlling means comprises means for changing the acoustic line direction of transmission and reception of the ultrasound pulse beam and the ultrasound echo beam to scan arterial walls in the body, the tissue velocity calculating means comprises means for calculating a velocity of the arterial walls in a direction of a normal, a distance traveled by the arterial walls in the direction of the normal, a velocity of the arterial walls in a direction of a tangent, and a distance traveled by the arterial walls in the direction of the tangent from the phase-detection result signal, and the display means comprises means for indicating the calculated velocity of the arterial walls in the direction of the normal, the calculated distance traveled by the arterial walls in the direction of the normal, the calculated velocity of the arterial walls in the direction of the tangent, and the calculated distance traveled by the arterial walls in the direction of the tangent as waveforms.

35 [0018] A sixth aspect of this invention is based on the fourth aspect thereof, and provides an ultrasound diagnostic apparatus wherein the display means comprises means for indicating a B-mode image of the body, and means for indicating the calculated velocity of the tissue in the direction perpendicular to the front surface of the ultrasound probe, the calculated distance traveled by the tissue in the direction perpendicular to the front surface of the ultrasound probe, the calculated velocity of the tissue in the direction parallel to the front surface of the ultrasound probe, and the calculated distance traveled by the tissue in the direction parallel to the front surface of the ultrasound probe as two-dimensional color distributions superimposed over the B-mode image of the body.

40 [0019] A seventh aspect of this invention is based on the fifth aspect thereof, and provides an ultrasound diagnostic apparatus wherein the display means comprises means for indicating a B-mode image of the body, and means for indicating the calculated velocity of the arterial walls in the direction of the normal, the calculated distance traveled by the arterial walls in the direction of the normal, the calculated velocity of the arterial walls in the direction of the tangent, and the calculated distance traveled by the arterial walls in the direction of the tangent as two-dimensional color distributions superimposed over the B-mode image of the body.

45 [0020] An eighth aspect of this invention is based on the sixth aspect thereof, and provides an ultrasound diagnostic apparatus wherein the display means comprises means for indicating a blood pressure waveform and an electrocardiogram superimposed over the B-mode image of the body and the two-dimensional color distributions.

50 [0021] A ninth aspect of this invention is based on the seventh aspect thereof, and provides an ultrasound diagnostic apparatus wherein the display means comprises means for indicating a blood pressure waveform and an electrocardiogram superimposed over the B-mode image of the body and the two-dimensional color distributions.

55 [0022] A tenth aspect of this invention is based on the first aspect thereof, and provides an ultrasound diagnostic apparatus comprising first means for transmitting a first ultrasound pulse beam into a body toward an object within the body along a first direction; second means for receiving a first ultrasound echo beam caused by reflection of the first ultrasound pulse beam at the object and coming from the object along the first direction; third means for transmitting a second ultrasound pulse beam into the body toward the object within the body along a second direction angularly different from the first direction; fourth means for receiving a second ultrasound echo beam caused by reflection of the second

ultrasound pulse beam at the object and coming from the object along the second direction; fifth means for calculating a velocity of the object along the first direction from the first ultrasound echo beam received by the second means; and sixth means for calculating a velocity of the object along the second direction from the second ultrasound echo beam received by the fourth means.

5 **[0023]** An eleventh aspect of this invention is based on the tenth aspect thereof, and provides an ultrasound diagnostic apparatus wherein the first direction is perpendicular to a surface of the body, and further comprising seventh means for calculating a velocity of the object along a third direction parallel to the surface of the body from the velocity calculated by the fifth means, the velocity calculated by the sixth means, and an angular difference between the first direction and the second direction.

10 **[0024]** A twelfth aspect of this invention is based on the tenth aspect thereof, and provides an ultrasound diagnostic apparatus further comprising seventh means for calculating a direction of motion of the object from the velocity calculated by the fifth means, the velocity calculated by the sixth means, and an angular difference between the first direction and the second direction, and eighth means for calculating a velocity of the object along the calculated direction of motion of the object from the velocity calculated by the fifth means, the velocity calculated by the sixth means, and the angular difference between the first direction and the second direction.

BRIEF DESCRIPTION OF THE DRAWINGS

[0025]

20 Fig. 1 is a block diagram of an ultrasound diagnostic apparatus according to an embodiment of this invention.
 Fig. 2 is a diagram of an ultrasound probe, acoustic line directions, and an object.
 Fig. 3 is a diagram of an ultrasound probe, acoustic line directions, and objects.
 Fig. 4 is a diagram of an ultrasound probe, acoustic line directions, and objects.
 25 Fig. 5 is a diagram of an ultrasound probe, acoustic line directions, measurement points, and curved arterial walls.
 Fig. 6 is a diagram of an ultrasound probe, an object, and a color of indication of the object.
 Fig. 7 is a diagram of an ultrasound probe, measurement points, arterial walls, and colors of indication of the measurement points.

30 DESCRIPTION OF THE PREFERRED EMBODIMENT

[0026] Fig. 1 shows an ultrasound diagnostic apparatus according to an embodiment of this invention. The apparatus of Fig. 1 includes an ultrasound probe 1, a monitor (display) 12, and an apparatus body 13. The ultrasound probe 1 and the monitor 12 are connected to the apparatus body 13. In addition, a blood pressure detector 15 and an electrocardiograph (ECG) 16 can be connected to the apparatus body 13.

35 **[0027]** The apparatus body 13 includes a transmitting/receiving section 2, a delay controller 3, a memory 4, a phase detector 5, a filter 6, a calculator 7, a memory 8, a digital scan converter (DSC) 9, a display controller 10, and a CPU 11. The transmitting/receiving section 2 is connected to the ultrasound probe 1, the delay controller 3, and the CPU 11. The delay controller 3 is connected to the memory 4, the phase detector 5, and the CPU 11. The memory 4 is connected to the CPU 11. The phase detector 5 is connected to the filter 6. The filter 6 is connected to the calculator 7 and the CPU 11. The calculator 7 is connected to the memory 8, the DSC 9, and the CPU 11. The memory 8 is connected to the CPU 11. The DSC 9 is connected to the display controller 10 and the CPU 11. The display controller 10 is connected to the CPU 11 and the monitor 12. The blood pressure detector 15 and the ECG 16 can be connected to the display controller 10.

45 **[0028]** The CPU 11 operates in accordance with a program stored in an internal memory or an external memory. According to the program, the CPU 11 controls the transmitting/receiving section 2, the delay controller 3, the memory 4, the filter 6, the calculator 7, the memory 8, the DSC 9, and the display controller 10. The CPU 11 can change operation of the apparatus among a plurality of different modes in response to user's request.

50 **[0029]** As shown in Fig. 2, the ultrasound probe 1 includes an array 14 of piezoelectric elements (electric-ultrasound transducer elements). The ultrasound probe 1 is applied to the surface of a body to be examined. In this case, as shown in Fig. 2, the piezoelectric-element array 14 adjoins the body surface. The ultrasound probe 1 has a flat front surface to be in contact with the body surface. The front surface of the ultrasound probe 1 substantially coincides with a front surface of the piezoelectric-element array 14.

55 **[0030]** With reference back to Fig. 1, the transmitting/receiving section 2 generates electric drive pulse signals for the piezoelectric elements in the ultrasound probe 1 according to the control by the CPU 11. The electric drive pulse signals have a given period. The transmitting/receiving section 2 feeds the electric drive pulse signals to the piezoelectric elements in the ultrasonic probe 1. The piezoelectric element array 14 in the ultrasonic probe 1 converts the electric drive pulse signals into a beam of corresponding ultrasound pulses, and emits the ultrasound pulse beam into a body

to be examined.

[0031] Under the control by the CPU 11, the delay controller 3 adjusts delays of the electric drive pulse signals applied to the piezoelectric elements in the ultrasonic probe 1 from the transmitting/receiving section 2, thereby changing the direction of the acoustic line of the emitted ultrasound pulse beam. In other words, the delay controller 3 controls the transmitting directivity of the piezoelectric element array 14 in the ultrasound probe 1. Specifically, the memory 4 stores data for transmission delay control. The delay controller 3 reads the transmission delay control data from the memory 4, and controls the delays of the electric drive pulse signals in accordance with the transmission delay control data.

[0032] The transmission delay control data in the memory 4 correspond to preset different deflection angles of the acoustic line of the emitted ultrasound pulse beam. Thus, the acoustic line of the emitted ultrasound pulse beam is changed among the preset deflection angles.

[0033] The emitted ultrasound pulse beam is reflected at various places within the body. The reflection-resultant ultrasound pulse beams are ultrasound echo beams. Portions of the ultrasound echo beams return to the piezoelectric elements in the ultrasound probe 1. The piezoelectric elements convert the received portions of the ultrasound echo beams into corresponding electric echo signals. The ultrasound probe 1 outputs the electric echo signals to the transmitting/receiving section 2.

[0034] The transmitting/receiving section 2 amplifies the electric echo signals. The transmitting/receiving section 2 outputs the amplification-resultant electric echo signals to the delay controller 3.

[0035] Under the control by the CPU 11, the delay controller 3 adjusts delays of the amplification-resultant electric echo signals, and adds or combines the delay-adjusted electric echo signals into a received echo signal being a signal (a Doppler-shift signal) having a Doppler shift or a Doppler frequency. Thereby, the delay controller changes the direction of the acoustic line of an ultrasound echo beam most sensitively received. This action of the delay controller 3 is equivalent to control of the receiving directivity of the piezoelectric element array 14 in the ultrasound probe 1. Specifically, the memory 4 stores data for reception delay control. The delay controller 3 reads the reception delay control data from the memory 4, and controls the delays of the electric echo signals in accordance with the reception delay control data. The delay controller 3 outputs the Doppler-shift signal to the phase detector 5.

[0036] The reception delay control data in the memory 4 correspond to the preset different deflection angles of the acoustic line of an ultrasound echo beam most sensitively received. Thus, the acoustic line of the ultrasound echo beam most sensitively received is changed among the preset deflection angles.

[0037] The phase detector 5 subjects the Doppler-shift signal to phase detection regarding the Doppler shift (the Doppler frequency) relative to a reference signal. The phase detection generates a real-part signal and an imaginary-part signal (a positive-polarity signal and a negative-polarity signal) in response to the Doppler-shift signal. The phase detector 5 outputs the real-part signal and the imaginary-part signal to the filter 6.

[0038] The real-part signal and the imaginary-part signal have desired echo components representing organ and tissue motions and also unwanted echo components representing blood flows and others. Under the control by the CPU 11, the filter 6 removes the unwanted echo components from the real-part signal and the imaginary-part signal while passing the desired echo components thereof. The filter 6 outputs the resultant real-part signal and the resultant imaginary-part signal to the calculator 7.

[0039] Under the control by the CPU 11, the calculator 7 computes the velocity of an object such as an organ or a tissue in the body on the basis of the output signals from the filter 6. Thus, the velocity of the object is measured. The calculator 7 generates data (velocity data) representing the computed object velocity, that is, the measured object velocity. The calculator 7 outputs the velocity data to the DSC 9.

[0040] Preferably, an ultrasound pulse beam is repetitively emitted in a same direction a plurality of times. In this case, a related ultrasound echo beam coming along the direction is repetitively received the plurality of times, and velocity data are generated the plurality of times. The calculator 7 stores each of the plural-time velocity data into the memory 8. The calculator 7 reads the plural-time velocity data from the memory 8. The calculator 7 averages the plural-time velocity data into mean velocity data. The calculator 7 outputs the mean velocity data to the DSC 9 instead of the non-average velocity data.

[0041] The calculator 7 stores the velocity data (the non-average velocity data or the mean velocity data) into the memory 8 for later use as previous velocity data. The calculator 7 computes the distance traveled by the object on the basis of the present velocity data (the present non-average velocity data or the present mean velocity data) and the previous velocity data read out from the memory 8. The calculator 7 generates data (traveled-distance data) representing the computed distance traveled by the object. The calculator 7 outputs the traveled-distance data to the DSC 9.

[0042] Under the control by the CPU 11, the DSC 9 subjects the output data from the calculator 7 to scan conversion, and thereby converts the data into a video signal of a given format suited for indication on the monitor 12. The DSC 9 outputs the video signal to the display controller 10.

[0043] In the case where the blood pressure detector 15 and the ECG 16 are connected to the display controller 10, the blood pressure detector 15 and the ECG 16 output signals to the display controller 10 which represent a blood pressure waveform and an electrocardiogram respectively. Under the control by the CPU 11, the display controller 10

converts the output signals of the blood pressure detector 15 and the ECG 16 into video signals of the given format suited for indication on the monitor 12. The display controller 10 superimposes these video signals on the video signal outputted from the DSC 9. The display controller 10 outputs the superimposition-resultant video signal to the monitor 12. The monitor 12 visualizes and indicates the output signal of the display controller 10. Thus, the velocity of the object, the distance traveled by the object, the blood pressure waveform, and the electrocardiogram are displayed on the monitor 12.

[0044] The ultrasound diagnostic apparatus implements the measurement of the velocity of an object or the velocities of objects in one of first, second, third, fourth, and fifth methods mentioned hereinafter.

[0045] According to the first measurement method, as shown in Fig. 2, a direction perpendicular to the front surface of the ultrasound probe 1 is defined as an "x" direction while a direction parallel to the front surface of the ultrasound probe 1 is defined as a "z" direction. The velocity of an object OB is measured by using emitted and received ultrasound beams in an acoustic line direction #1 equal to the "x" direction. The measured object velocity is denoted by V_x . The acoustic line of the direction #1 meets the object OB. In addition, the velocity of the object OB is measured by using emitted and received ultrasound beams in an acoustic line direction #2 which deflects from the acoustic line direction #1 by a given angle θ . The measured object velocity is denoted by V' . The acoustic line of the direction #2 meets the object OB. In the case where the object OB is moving only in the "x" direction, the measured object velocity V' regarding the acoustic line direction #2 and the measured object velocity V_x regarding the acoustic line direction #1 are in the following relation.

$$V' = V_x \cdot \cos\theta \quad \dots(1)$$

On the other hand, in the case where the motion of the object OB has a nonzero "z"-direction component, the measured object velocities V' and V_x are in the following relation.

$$V' > V_x \cdot \cos\theta \quad \dots(2)$$

For example, the calculator 7 decides which of the relations (1) and (2) is satisfied. When the relation (1) is satisfied, it is determined that the object OB is moving only in the "x" direction. In this case, the measured object velocity V_x is used as an actual measured object velocity. When the relation (2) is satisfied, it is determined that the direction of motion of the object OB has a nonzero "z"-direction component. In this case, the measured object velocity V' is greater than the value " $V_x \cdot \cos\theta$ " by a quantity which increases as the "z"-direction component of the object motion increases. The object velocity V_z in the "z" direction is estimated or calculated from the difference between the measured object velocity V' and the value " $V_x \cdot \cos\theta$ ". An actual measured object velocity (that is, a velocity of an object in a direction of motion thereof) V is calculated from the object velocity V_x and the object velocity V_z . In addition, an actual direction of motion of the object is calculated from the object velocity V_x and the object velocity V_z . According to the first measurement method, the velocity of an object OB may be repetitively measured by using emitted and received ultrasound beams in three or more different acoustic line directions.

[0046] According to the second measurement method, as shown in Fig. 3, the velocity of an object OB1 and the velocity of an object OB2 are measured by using emitted and received ultrasound beams in an acoustic line direction #1 equal to the "x" direction. The objects OB1 and OB2 align in the "x" direction. The acoustic line of the direction #1 meets the objects OB1 and OB2. The position of the object OB 1 is deeper than the position of the object OB2 with respect to the body surface. In addition, the velocity of the object OB 1 is measured by using emitted and received ultrasound beams in an acoustic line direction #2 which deflects from the acoustic line direction #1 by a given angle θ . The acoustic line of the direction #2 meets the object OB1. Furthermore, the velocity of the object OB2 is measured by using emitted and received ultrasound beams in an acoustic line direction #2' parallel to and separate from the acoustic line direction #2. The acoustic line of the direction #2' meets the object OB2. The acoustic line directions #2 and #2' are equal in deflection angle relative to the acoustic line direction #1. An actual measured velocity of the object OB1, and an actual direction of motion of the object OB1 are calculated as in the first measurement method. Similarly, an actual measured velocity of the object OB2, and an actual direction of motion of the object OB2 are calculated as in the first measurement method. The emitted and received ultrasound beams in the acoustic line direction #2 or the acoustic line direction #2' are provided by steps including a step of selecting piezoelectric elements from the piezoelectric-element array 14 as a group of actively-used piezoelectric elements. The replacement of the emitted and received ultrasound beams in the acoustic line direction #2 by those in the acoustic line direction #2' is implemented by shifting the group of actively-used piezoelectric elements relative to the piezoelectric-element array 14 while holding unchanged the signal

delays related to the actively-used piezoelectric elements. According to the second measurement method, the velocities of three or more objects at different depths may be measured.

[0047] According to the third measurement method, as shown in Fig. 4, the velocity of an object OB1 and the velocity of an object OB2 are measured by using emitted and received ultrasound beams in an acoustic line direction #1 equal to the "x" direction. The objects OB 1 and OB2 align in the "x" direction. The acoustic line of the direction #1 meets the objects OB1 and OB2. The position of the object OB1 is deeper than the position of the object OB2 with respect to the body surface. In addition, the velocity of the object OB1 is measured by using emitted and received ultrasound beams in an acoustic line direction #2 which deflects from the acoustic line direction #1 by a given angle θ . The acoustic line of the direction #2 meets the object OB1. Furthermore, the velocity of the object OB2 is measured by using emitted and received ultrasound beams in an acoustic line direction #3 which deflects from the acoustic line direction #1 by a given angle θ' different from the given angle θ . The acoustic line of the direction #3 meets the object OB2. An actual measured velocity of the object OB1, and an actual direction of motion of the object OB1 are calculated as in the first measurement method. Similarly, an actual measured velocity of the object OB2, and an actual direction of motion of the object OB2 are calculated as in the first measurement method. The emitted and received ultrasound beams in the acoustic line direction #2 or the acoustic line direction #3 are provided by steps including a step of selecting piezoelectric elements from the piezoelectric-element array 14 as a group of actively-used piezoelectric elements. The replacement of the emitted and received ultrasound beams in the acoustic line direction #2 by those in the acoustic line direction #3 is implemented by controlling or changing the signal delays related to the actively-used piezoelectric elements without changing the selection of the actively-used piezoelectric elements. According to the third measurement method, the velocities of three or more objects at different depths may be measured.

[0048] The fourth measurement method is similar to one of the first, second, and third measurement methods except for design changes mentioned hereinafter. With reference to Fig. 2, the previously-mentioned relation (2) is changed into a general equation as follows.

$$V' = (V_x + A) \cdot \cos\theta \quad \dots(3)$$

where "A" denotes a value defined along the "x" direction (the acoustic line direction #1) and related to a "z"-direction component of the motion of the object OB. The value "A" is different from 0 when a nonzero "z"-direction component is present in the motion of the object OB. The value "A" is equal to 0 when a nonzero "z"-direction component is absent from the motion of the object OB. The equation (3) is changed into the following equations.

$$V_x + A = V' / \cos\theta \quad \dots(4)$$

$$A = (V' / \cos\theta) - V_x \quad \dots(5)$$

As shown in Fig. 2, the value "A", the angle θ , and the object velocity V_z in the "z" direction are in the following relation.

$$A = V_z \cdot \tan\theta \quad \dots(6)$$

Combining the equation (5) and the relation (6) results in an equation as follows.

$$V_z = (1/\sin\theta) \cdot (V' - V_x \cdot \cos\theta) \quad \dots(7)$$

The object velocity V_z in the "z" direction is calculated from the measured object velocities V_x and V' , and the angle θ by using the equation (7). An actual measured object velocity V is calculated from the "x"-direction object velocity V_x and the "z"-direction object velocity V_z in accordance with the following equation.

$$V = (V_x^2 + V_z^2)^{1/2} \quad \dots(8)$$

5 The angle θ_v of the direction of motion of the object OB relative to the front surface of the ultrasound probe 1 is calculated from the "x"-direction object velocity V_x and the "z"-direction object velocity V_z by using an equation as follows.

$$\theta_v = \tan^{-1}(V_z/V_x) \quad \dots(9)$$

10

It should be noted that the object velocity V_x regarding the acoustic line direction #1 and the object velocity V' regarding the acoustic line direction #2 may be detected by an FFT Doppler technique. The body to be examined may be scanned by an ultrasound beam to spatially detect the rate and direction of motion.

15

[0049] The fifth measurement method is similar to one of the first, second, third, and fourth measurement methods except for design changes mentioned hereinafter. The fifth measurement method is suited for detection of motion parameters of arterial walls which curve relative to the surface of the body, that is, the front surface of the ultrasound probe 1. According to the fifth measurement method, a B-mode image (a sectional image) of the body is indicated on the monitor 12. With reference to Fig. 5, an image of arterial walls in the B-mode image of the body is traced, and spaced measurement points P1, P2, and P3 are defined on the image of the arterial walls. Transmission delay control data for enabling the ultrasound pulse beams to hit the measurement points P1, P2, and P3 are individually calculated. For each of the measurement points P1, P2, and P3, the calculated transmission delay control data correspond to ultrasound pulse beams in two different acoustic line directions. Reception delay control data for sensitively catching the ultrasound echo beams coming from the measurement points P1, P2, and P3 are individually calculated. The calculated transmission delay control data and the calculated reception delay control data are stored in the memory 4. The delay controller 3 reads the transmission delay control data from the memory 4, and controls the delays of the electric drive pulse signals in accordance with the transmission delay control data. Thus, the measurement points P1, P2, and P3 are sequentially hit by the ultrasound pulse beams. The delay controller 3 reads the reception delay control data from the memory 4, and controls the delays of the electric echo signals in accordance with the reception delay control data. Thus, the ultrasound echo beams coming from the measurement points P1, P2, and P3 are sequentially received. Velocities of each of the measurement points P1, P2, and P3 regarding two different acoustic line directions are measured as in the fourth measurement method. The measured velocities of the measurement points P1, P2, and P3 are indicated on the monitor 12 as a waveform. Thereby, it is possible to easily grasp motion of the arterial walls along the direction of a normal and also motion thereof along the direction of a tangent. Furthermore, the velocity of each of the measurement points P1, P2, and P3 along the direction of a normal and the velocity thereof along the direction of a tangent may be calculated. In this case, the calculated velocities of the measurement points P1, P2, and P3 are indicated on the monitor 12.

20

25

30

35

[0050] The ultrasound diagnostic apparatus implements the indication of the measurement results on the monitor 12 in one of first, second, third, and fourth methods mentioned hereinafter.

40

[0051] The first indication method is applied to the measurement results provided in the fourth measurement method. Specifically, the velocity of a tissue (or an organ) in the body along a direction perpendicular to the front surface of the ultrasound probe 1, and also the velocity of the tissue (or the organ) along a direction parallel to the front surface of the ultrasound probe 1 are two-dimensionally measured in the fourth measurement method while the body is scanned by the ultrasound pulse beam. The measurement results are indicated on the monitor 12 as a color distribution superimposed over the B-mode image of the body. In addition, the distance traveled by the tissue (or the organ) along the direction perpendicular to the front surface of the ultrasound probe 1, and also the distance traveled by the tissue (or the organ) along the direction parallel to the front surface of the ultrasound probe 1 are calculated while the body is scanned by the ultrasound pulse beam. The calculation results are indicated on the monitor 12 as a color distribution superimposed over the B-mode image of the body. Thereby, it is possible to easily grasp motion of a local place in the tissue (or the organ). According to the first indication method, as shown in Fig. 6, an object is indicated by a red region when the object is moving toward the ultrasound probe 1. The tone of the red is increased as the measured velocity of the object rises. An object is indicated by a blue region when the object is moving away from the ultrasound probe 1. The tone of the blue is increased as the measured velocity of the object rises. An object is indicated by a green region when the object is moving in one direction (for example, the rightward direction as viewed in Fig. 6) parallel to the front surface of the ultrasound probe 1. The tone of the green is increased as the measured velocity of the object rises. An object is indicated by a yellow region when the object is moving in the other direction (for example, the leftward direction as viewed in Fig. 6) parallel to the front surface of the ultrasound probe 1. The tone of the yellow is increased as the measured velocity of the object rises. When an object is moving in a direction intermediate between the upward direction and the rightward direction as viewed in Fig. 6, the object is indicated by a region having a color intermediate between red and green. It

45

50

55

should be noted that red, blue, green, and yellow may be replaced by other colors. Used colors may be freely selected by a user.

[0052] The second indication method is applied to the measurement results provided in the fifth measurement method. According to the second indication method, the velocity of arterial walls along the direction of a normal and also the velocity thereof along the direction of a tangent are indicated on the monitor 12 as two-dimensional color distributions superimposed over the B-mode image of the body. In addition, the distance traveled by the arterial walls along the direction of the normal and also the distance traveled thereby along the direction of the tangent are indicated on the monitor 12 as two-dimensional color distributions superimposed over the B-mode image of the body. Thereby, it is possible to easily grasp motion of the arterial walls which is caused by a heartbeat. As shown in Fig. 7, each measurement point (P1, P2, or P3) on the arterial walls is indicated by a red region when the measurement point is moving in a radially inward direction (one direction of a normal). The tone of the red is increased as the velocity of the measurement point rises. Each measurement point (P1, P2, or P3) on the arterial walls is indicated by a blue region when the measurement point is moving in a radially outward direction (the other direction of the normal). The tone of the blue is increased as the velocity of the measurement point rises. Each measurement point (P1, P2, or P3) on the arterial walls is indicated by a green region when the measurement point is moving in one axial direction (one direction of a tangent). The tone of the green is increased as the velocity of the measurement point rises. Each measurement point (P1, P2, or P3) on the arterial walls is indicated by a yellow region when the measurement point is moving in the other axial direction (the other direction of the tangent). The tone of the yellow is increased as the velocity of the measurement point rises. It should be noted that red, blue, green, and yellow may be replaced by other colors. Used colors may be freely selected by a user.

[0053] The third indication method is similar to the first indication method (or the second indication method) except for design changes mentioned hereinafter. According to the third indication method, the blood pressure waveform and the electrocardiogram are displayed on the monitor 12 while being superimposed over the B-mode image of the body and the two-dimensional color distributions of the velocity of a tissue (or an organ) and the distance traveled by the tissue (or the organ). The superimposition is on a real-time basis. Thereby, it is possible to easily grasp motion of the tissue (or the organ) which is caused by a heartbeat.

[0054] The fourth indication method is similar to the second indication method (or the first indication method) except for design changes mentioned hereinafter. According to the fourth indication method, the blood pressure waveform and the electrocardiogram are displayed on the monitor 12 while being superimposed over the B-mode image of the body and the two-dimensional color distributions of the velocities of measurement points on arterial walls along the direction of a normal, the velocities of the measurement points along the direction of a tangent, the distances traveled by the measurement points along the direction of the normal, and the distances traveled by the measurement points along the direction of the tangent. The superimposition is on a real-time basis. Thereby, it is possible to easily grasp heartbeat-caused motion of the arterial walls along the direction of the normal and also heartbeat-caused motion thereof along the direction of the tangent.

Claims

1. An ultrasound diagnostic apparatus comprising:

transmitting means including an ultrasound probe including an array (14) of piezoelectric elements and adapted to transmit a plurality of ultrasound pulse beams having different acoustic line directions from the ultrasound probe (1) into a body, wherein defined spaced measurement points (P1, P2, P3) on an arterial wall in the body are sequentially hit by the ultrasound pulse beams;

receiving means including the ultrasound probe (1) adapted to receive ultrasound echo beams caused in the body, and converting the received ultrasound echo beams into corresponding electric echo signals via the ultrasound probe (1);

acoustic line direction calculating means adapted to individually calculate two different acoustic line directions for each of the measurement points (P1, P2, P3),

delay controlling means (3) adapted to control deflection angles of transmission and reception of the ultrasound pulse beams and the ultrasound echo beams in accordance with the calculated acoustic line directions, and selecting means selecting a first and a second group of actively-used piezoelectric elements from the array (14) of piezoelectric elements in accordance with the calculated acoustic line directions, the second group being

shifted with respect to the first group wherein each of the measurement points (P1, P2, P3) is hit by a first ultrasound pulse beam and a second ultrasound pulse beam, the first ultrasound pulse beam and the second ultrasound pulse beam having different deflection angles to each other, all first ultrasound pulse beams having different deflection angles to each other and being transmitted by the first group of actively-used piezoelectric

elements, and all second ultrasound pulse beams having different deflection angles to each other and being transmitted by the shifted second group of actively-used piezoelectric elements;
 phase detection means (5) adapted to subject the electric echo signals to phase detection to generate phase-detection result signals;
 tissue velocity calculating means (7) adapted to calculate velocities of the measurement points (P1, P2, P3) in the directions of a normal and a tangent of the arterial wall from the phase-detection result signals; and
 display means (12) adapted to indicate the calculated velocities of the measurement points (P1, P2, P3).

2. An ultrasound diagnostic apparatus as recited in claim 1, wherein the ultrasound probe (1) includes transducer elements, and further comprising means for selecting ones from among the transducer elements as active elements in response to a depth of a measured portion of the tissue from a surface of the body.
3. An ultrasound diagnostic apparatus as recited in claim 1, wherein the delay controlling means (3) comprises means for changing the deflection angle of transmission and reception of the ultrasound pulse beam and the ultrasound echo beam in response to a depth of a measured portion of the tissue from a surface of the body.
4. An ultrasound diagnostic apparatus as recited in claim 1, wherein the delay controlling means (3) comprises means for changing the acoustic line direction of transmission and reception of the ultrasound pulse beam and the ultrasound echo beam among a plurality of different directions with respect to the tissue, and the tissue velocity calculating means (7) comprises means for calculating a velocity (V_x) of the tissue in a direction perpendicular to a front surface of the ultrasound probe (1), a distance traveled by the tissue in the direction perpendicular to the front surface of the ultrasound probe (1), a velocity (V_z) of the tissue in a direction parallel to the front surface of the ultrasound probe (1), and a distance traveled by the tissue in the direction parallel to the front surface of the ultrasound probe (1) from the phase-detection result signal.
5. An ultrasound diagnostic apparatus as recited in claim 1, wherein the delay controlling means (3) comprises means for changing the acoustic line direction of transmission and reception of the ultrasound pulse beam and the ultrasound echo beam to scan arterial walls in the body, the tissue velocity calculating means (7) comprises means for calculating a velocity of the arterial walls in a direction of a normal, a distance traveled by the arterial walls in the direction of the normal, a velocity of the arterial walls in a direction of a tangent, and a distance traveled by the arterial walls in the direction of the tangent from the phase-detection result signal, and the display means (12) comprises means for indicating the calculated velocity of the arterial walls in the direction of the normal, the calculated distance traveled by the arterial walls in the direction of the normal, the calculated velocity of the arterial walls in the direction of the tangent, and the calculated distance traveled by the arterial walls in the direction of the tangent as waveforms.
6. An ultrasound diagnostic apparatus as recited in claim 4, wherein the display means (12) comprises means for indicating a B-mode image of the body, and means for indicating the calculated velocity (V_x) of the tissue in the direction perpendicular to the front surface of the ultrasound probe (1), the calculated distance traveled by the tissue in the direction perpendicular to the front surface of the ultrasound probe (1), the calculated velocity (V_z) of the tissue in the , direction parallel to the front surface of the ultrasound probe (1), and the calculated distance traveled by the tissue in the direction parallel to the front surface of the ultrasound probe as two-dimensional color distributions superimposed over the B-mode image of the body.
7. An ultrasound diagnostic apparatus as recited in claim 5, wherein the display means (12) comprises means for indicating a B-mode image of the body, and means for indicating the calculated velocity of the arterial walls in the direction of the normal, the calculated distance traveled by the arterial walls in the direction of the normal, the calculated velocity of the arterial walls in the direction of the tangent, and the calculated distance traveled by the arterial walls in the direction of the tangent as two-dimensional color distributions superimposed over the B-mode image of the body.
8. An ultrasound diagnostic apparatus as recited in claim 6, wherein the display means (12) comprises means for indicating a blood pressure waveform and an electrocardiogram superimposed over the B-mode image of the body and the two-dimensional color distributions.
9. An ultrasound diagnostic apparatus as recited in claim 7, wherein the display means (12) comprises means for indicating a blood pressure waveform and an electrocardiogram superimposed over the B-mode image of the body and the two-dimensional color distributions.

10. An ultrasound diagnostic apparatus as recited in claim 1, wherein the transmitting and receiving means comprise :

first means (1) for transmitting a first ultrasound pulse beam into a body toward an object within the body along a first direction;

second means (1) for receiving a first ultrasound echo beam caused by reflection of the first ultrasound pulse beam at the object and coming from the object along the first direction;

third means (1) for transmitting a second ultrasound pulse beam into the body toward the object within the body along a second direction angularly different from the first direction; and

fourth means (1) for receiving a second ultrasound echo beam fourth means (1) for receiving a second ultrasound echo beam caused by reflection of the second ultrasound pulse beam at the object and coming from the object along the second direction; and

wherein the tissue velocity means comprise :

fifth means (7) for calculating a velocity (V_x) of the object along the first direction from the first ultrasound echo beam received by the second means (1); and

sixth means (7) for calculating a velocity (V') of the object along the second direction from the second ultrasound echo beam received by the fourth means (1).

11. An ultrasound diagnostic apparatus as recited in claim 10, wherein the first direction is perpendicular to a surface of the body, and further comprising seventh means (7) for calculating a velocity (V_z) of the object along a third direction parallel to the surface of the body from the velocity (V_x) calculated by the fifth means (7), the velocity (V') calculated by the sixth means (7), and an angular difference (θ) between the first direction and the second direction.

12. An ultrasound diagnostic apparatus as recited in claim 10, further comprising seventh means (7) for calculating a direction of motion of the object from the velocity (V_x) calculated by the fifth means (7), the velocity (V') calculated by the sixth means (7), and an angular difference (θ) between the first direction and the second direction, and eighth means (7) for calculating a velocity (V) of the object along the calculated direction of motion of the object from the velocity (V_x) calculated by the fifth means (7), the velocity (V') calculated by the sixth means (7), and the angular difference (θ) between the first direction and the second direction.

Patentansprüche

1. Ultraschall Diagnosevorrichtung, umfassend:

ein Übertragungsmittel, das eine Ultraschallsonde einschließlich einer Anordnung (14) von piezoelektrischen Elementen umfasst und geeignet ist, um mehrere Ultraschallimpulsstrahlen mit verschiedenen Akustikstreckenrichtungen von der Ultraschallsonde (1) in einen Körper zu übertragen, wobei definierte voneinander beabstandete Messpunkte (P1, P2, P3) an einer Arterienwand in dem Körper durch die Ultraschallimpulsstrahlen sequentiell getroffen werden;

ein Empfangsmittel, das die Ultraschallsonde (1) umfasst und geeignet ist, um in dem Körper verursachte Ultraschallechostrahlen zu empfangen und die empfangenen Ultraschallechostrahlen über die Ultraschallsonde (1) in entsprechende elektrische Echosignale umzuwandeln;

ein Akustikstreckenrichtungs-Berechnungsmittel, das geeignet ist, um zwei verschiedene Akustikstreckenrichtungen für jeden der Messpunkte (P1, P2, P3) individuell zu berechnen,

ein Verzögerungssteuermittel (3), das geeignet ist, um Ablenkwinkel einer Übertragung und eines Empfangs der Ultraschallimpulsstrahlen und der Ultraschallechostrahlen entsprechend den berechneten Akustikstreckenrichtungen zu steuern, und ein Auswahlmittel, das eine erste und eine zweite Gruppe von aktiv verwendeten piezoelektrischen Elementen aus der Anordnung (14) von piezoelektrischen Elementen entsprechend den berechneten Akustikstreckenrichtungen auswählt, wobei die zweite Gruppe in Bezug auf die erste Gruppe verschoben ist, wobei alle Messpunkte (P1, P2, P3) durch einen ersten Ultraschallimpulsstrahl und einen zweiten Ultraschallimpulsstrahl getroffen werden, wobei der erste Ultraschallimpulsstrahl und der zweite Ultraschallimpulsstrahl verschiedene Ablenkwinkel zueinander aufweisen, wobei alle ersten Ultraschallimpulsstrahlen verschiedene Ablenkwinkel zueinander aufweisen und durch die erste Gruppe von aktiv verwendeten piezoelektrischen Elementen übertragen werden, und alle zweiten Ultraschallimpulsstrahlen verschiedene Ablenkwinkel zueinander aufweisen und durch die verschobene zweite Gruppe von aktiv verwendeten piezoelektrischen Elementen übertragen werden;

ein Phasendetektionsmittel (5), das geeignet ist, um die elektrischen Echosignale einer Phasendetektion zu unterziehen, um Phasendetektions-Ergebnissignale zu erzeugen;

ein Gewebegeschwindigkeits-Berechnungsmittel (7), das geeignet ist, um Geschwindigkeiten der Messpunkte (P1, P2, P3) in den Richtungen einer Senkrechten und einer Tangente der Arterienwand aus den Phasendetektions-Ergebnissignalen zu berechnen; und

ein Anzeigemittel (12), das geeignet ist, um die berechneten Geschwindigkeiten der Messpunkte (P1, P2, P3) anzugeben.

2. Ultraschalldiagnosevorrichtung nach Anspruch 1, wobei die Ultraschallsonde (1) Transducer-Elemente umfasst, ferner umfassend ein Mittel zum Auswählen einiger aus den Transducer-Elementen als aktive Elemente in Ansprechen auf eine Tiefe eines gemessenen Abschnitts des Gewebes von einer Oberfläche des Körpers.
3. Ultraschalldiagnosevorrichtung nach Anspruch 1, wobei das Verzögerungssteuermittel (3) ein Mittel zum Ändern des Ablenkwinkels der Übertragung und des Empfangs des Ultraschallimpulsstrahls und des Ultraschallechostrahls in Ansprechen auf eine Tiefe eines gemessenen Abschnitts des Gewebes von einer Oberfläche des Körpers umfasst.
4. Ultraschalldiagnosevorrichtung nach Anspruch 1, wobei das Verzögerungssteuermittel (3) ein Mittel zum Ändern der Akustikstreckenrichtung einer Übertragung und eines Empfangs des Ultraschallimpulsstrahls und des Ultraschallechostrahls unter mehreren verschiedenen Richtungen in Bezug auf das Gewebe umfasst, und das Gewebegeschwindigkeits-Berechnungsmittel (7) ein Mittel zum Berechnen einer Geschwindigkeit (V_x) des Gewebes in einer Richtung senkrecht zu einer Vorderseite der Ultraschallsonde (1), einer durch das Gewebe in der Richtung senkrecht zu der Vorderseite der Ultraschallsonde (1) zurückgelegten Distanz, einer Geschwindigkeit (V_z) des Gewebes in einer Richtung parallel zu der Vorderseite der Ultraschallsonde (1) und einer durch das Gewebe in der Richtung parallel zu der Vorderseite der Ultraschallsonde (1) zurückgelegten Distanz aus dem Phasendetektions-Ergebnissignal umfasst.
5. Ultraschalldiagnosevorrichtung nach Anspruch 1, wobei das Verzögerungssteuermittel (3) ein Mittel zum Ändern der Akustikstreckenrichtung der Übertragung und des Empfangs des Ultraschallimpulsstrahls und des Ultraschallechostrahls umfasst, um Arterienwände in dem Körper abzutasten, wobei das Gewebegeschwindigkeits-Berechnungsmittel (7) ein Mittel zum Berechnen einer Geschwindigkeit der Arterienwände in einer Richtung einer Senkrechten, einer durch die Arterienwände in der Richtung der Senkrechten zurückgelegten Distanz, einer Geschwindigkeit der Arterienwände in einer Richtung einer Tangente und einer durch die Arterienwände in der Richtung der Tangente zurückgelegten Distanz aus dem Phasendetektions-Ergebnissignal umfasst, und das Anzeigemittel (12) ein Mittel zum Angeben der berechneten Geschwindigkeit der Arterienwände in der Richtung der Senkrechten, der berechneten durch die Arterienwände in der Richtung der Senkrechten zurückgelegten Distanz, der berechneten Geschwindigkeit der Arterienwände in der Richtung der Tangente und der berechneten durch die Arterienwände in der Richtung der Tangente zurückgelegten Distanz als Wellenformen umfasst.
6. Ultraschalldiagnosevorrichtung nach Anspruch 4, wobei das Anzeigemittel (12) ein Mittel zum Angeben eines B-Modus-Bilds des Körpers und ein Mittel zum Angeben der berechneten Geschwindigkeit (V_x) des Gewebes in der Richtung senkrecht zu der Vorderseite der Ultraschallsonde (1), der berechneten durch das Gewebe in der Richtung senkrecht zu der Vorderseite der Ultraschallsonde (1) zurückgelegten Distanz, der berechneten Geschwindigkeit (V_z) des Gewebes in der Richtung parallel zu der Vorderseite der Ultraschallsonde (1) und der berechneten durch das Gewebe in der Richtung parallel zu der Vorderseite der Ultraschallsonde zurückgelegten Distanz als dem B-Modus-Bild des Körpers überlagerte zweidimensionale Farbverteilungen umfasst.
7. Ultraschalldiagnosevorrichtung nach Anspruch 5, wobei das Anzeigemittel (12) ein Mittel zum Angeben eines B-Modus-Bilds des Körpers und ein Mittel zum Angeben der berechneten Geschwindigkeit der Arterienwände in der Richtung der Senkrechten, der berechneten von den Arterienwänden in der Richtung der Senkrechten zurückgelegten Distanz, der berechneten Geschwindigkeit der Arterienwände in der Richtung der Tangente und der berechneten durch die Arterienwände in der Richtung der Tangente zurückgelegten Distanz als dem B-Modus-Bild des Körpers überlagerte zweidimensionale Farbverteilungen umfasst.
8. Ultraschalldiagnosevorrichtung nach Anspruch 6, wobei das Anzeigemittel (12) ein Mittel zum Angeben einer Blutdruckwellenform und eines Elektrokardiogramms

umfasst, die dem B-Modus-Bild des Körpers und den zweidimensionalen Farbverteilungen überlagert sind.

9. Ultraschall Diagnosevorrichtung nach Anspruch 7,
wobei das Anzeigemittel (12) ein Mittel zum Angeben einer Blutdruckwellenform und eines Elektrokardiogramms
umfasst, die dem B-Modus-Bild des Körpers und den zweidimensionalen Farbverteilungen überlagert sind.

10. Ultraschall Diagnosevorrichtung nach Anspruch 1,
wobei das Übertragungs- und Empfangsmittel umfasst:

ein erstes Mittel (1) zum Übertragen eines ersten Ultraschallimpulsstrahls in einen Körper zu einem Objekt in dem Körper hin entlang einer ersten Richtung;
ein zweites Mittel (1) zum Empfangen eines ersten Ultraschallechostrahls, der durch Reflexion des ersten Ultraschallimpulsstrahls an dem Objekt verursacht wird und von dem Objekt entlang der ersten Richtung kommt;
ein drittes Mittel (1) zum Übertragen eines zweiten Ultraschallimpulsstrahls in den Körper zu dem Objekt in dem Körper hin entlang einer zweiten Richtung, die einen anderen Winkel als die erste Richtung aufweist; und
ein viertes Mittel (1) zum Empfangen eines zweiten Ultraschallechostrahls, der durch Reflexion des zweiten Ultraschallimpulsstrahls an dem Objekt verursacht wird und von dem Objekt entlang der zweiten Richtung kommt; und

wobei das Gewebegeschwindigkeitsmittel umfasst:

ein fünftes Mittel (7) zum Berechnen einer Geschwindigkeit (V_x) des Objekts entlang der ersten Richtung aus dem durch das zweite Mittel (1) empfangenen ersten Ultraschallechostrahl; und
ein sechstes Mittel (7) zum Berechnen einer Geschwindigkeit (V') des Objekts entlang der zweiten Richtung aus dem durch das vierte Mittel (1) empfangenen zweiten Ultraschallechostrahl.

11. Ultraschall Diagnosevorrichtung nach Anspruch 10,
wobei die erste Richtung zu einer Oberfläche des Körpers senkrecht ist, ferner umfassend ein siebtes Mittel (7) zum Berechnen einer Geschwindigkeit (V_z) des Objekts entlang einer dritten Richtung parallel zu der Oberfläche des Körpers aus der durch das fünfte Mittel (7) berechneten Geschwindigkeit (V_x), der durch das sechste Mittel (7) berechneten Geschwindigkeit (V') und einer Winkeldifferenz (θ) zwischen der ersten Richtung und der zweiten Richtung.

12. Ultraschall Diagnosevorrichtung nach Anspruch 10,
ferner umfassend ein siebtes Mittel (7) zum Berechnen einer Bewegungsrichtung des Objekts aus der durch das fünfte Mittel (7) berechneten Geschwindigkeit (V_x), der durch das sechste Mittel (7) berechneten Geschwindigkeit (V') und einer Winkeldifferenz (θ) zwischen der ersten Richtung und der zweiten Richtung, und ein achttes Mittel (7) zum Berechnen einer Geschwindigkeit (V) des Objekts entlang der berechneten Bewegungsrichtung des Objekts aus der durch das fünfte Mittel (7) berechneten Geschwindigkeit (V_x), der durch das sechste Mittel (7) berechneten Geschwindigkeit (V') und der Winkeldifferenz (θ) zwischen der ersten Richtung und der zweiten Richtung.

Revendications

1. Appareil de diagnostic à ultrasons, comprenant :

des moyens émetteurs incluant une sonde à ultrasons qui comprend un réseau (14) d'éléments piézoélectriques et adaptés à émettre une pluralité de faisceaux d'impulsions d'ultrasons présentant des directions de ligne acoustique différentes depuis la sonde à ultrasons (1) dans un corps, dans lequel des points de mesure espacés définis (P1, P2, P3) sur une paroi artérielle dans le corps sont atteints en séquence par les faisceaux d'impulsions à ultrasons ;

des moyens récepteurs incluant la sonde à ultrasons (1) adaptés à recevoir des faisceaux d'écho d'ultrasons provoqués dans le corps, et à convertir les faisceaux d'écho d'ultrasons reçus en signaux d'écho électriques correspondants via la sonde à ultrasons (1) ;

des moyens de calcul de direction de ligne acoustique adaptés à calculer individuellement deux directions de ligne acoustique différentes pour chacun des points de mesure (P1, P2, P3) et,

des moyens de commande de retard (3) adaptés à commander les angles de déflexion d'émission et de réception des faisceaux d'impulsion d'ultrasons et les faisceaux d'écho d'ultrasons en accord avec les directions de ligne

- acoustique calculées, et des moyens de sélection qui sélectionnent un premier groupe et un second groupe d'éléments piézoélectriques utilisés de manière active parmi le réseau (14) d'éléments piézoélectriques en accord avec les directions de ligne acoustique calculées, le second groupe étant décalé par rapport au premier groupe dans lequel chacun des points de mesure (P1, P2, P3) est atteint par un premier faisceau d'impulsions d'ultrasons et un second faisceau d'impulsions d'ultrasons, le premier faisceau d'impulsions d'ultrasons et le second faisceau d'impulsions d'ultrasons ayant des angles de déflexion différents l'un de l'autre, tous les premiers faisceaux d'impulsions d'ultrasons ayant des angles de déflexion différents les uns des autres et étant émis par le premier groupe d'éléments piézoélectriques utilisés de manière active, et tous les seconds faisceaux d'impulsions d'ultrasons ayant des angles de déflexion différents les uns des autres et étant émis par le second groupe décalé d'éléments piézoélectriques utilisés de manière active ;
 des moyens de détection de phase (5) adapté à soumettre les signaux d'écho électriques à une détection de phase pour générer des signaux résultants de détection de phase ;
 des moyens de calcul de vitesse de tissus (7) adaptés à calculer les vitesses des points de mesure (P1, P2, P3) dans les directions d'une normale et d'une tangente de la paroi artérielle à partir des signaux résultants de détection de phase ; et
 des moyens d'affichage (12) adaptés à indiquer les vitesses calculées des points de mesure (P1, P2, P3).
- 5
- 10
- 15
2. Appareil de diagnostic à ultrasons selon la revendication 1, dans lequel la sonde à ultrasons (1) inclut des éléments de transducteurs, et comprenant en outre des moyens pour sélectionner des premiers éléments parmi les éléments transducteurs à titre d'éléments actifs en réponse à une profondeur d'une portion mesurée des tissus depuis une surface du corps.
- 20
3. Appareil de diagnostic à ultrasons selon la revendication 1, dans lequel les moyens de commande de retard (3) comprennent des moyens pour changer l'angle de déflexion de l'émission et de la réception du faisceau d'impulsions d'ultrasons et du faisceau d'écho d'ultrasons en réponse à une profondeur d'une portion mesurée des tissus depuis une surface du corps.
- 25
4. Appareil de diagnostic à ultrasons selon la revendication 1, dans lequel les moyens de commande de retard (3) comprennent des moyens pour changer la direction de ligne acoustique de l'émission et de la réception du faisceau d'impulsions d'ultrasons et du faisceau d'écho d'ultrasons parmi une pluralité de directions différentes par rapport aux tissus, et les moyens de calcul de vitesse de tissus (7) comprennent des moyens pour calculer une vitesse (Vx) des tissus dans une direction perpendiculaire à une surface frontale de la sonde à ultrasons (1), une distance parcourue par les tissus dans la direction perpendiculaire à la surface frontale de la sonde à ultrasons (1), une vitesse (Vz) des tissus dans une direction parallèle à la surface frontale de la sonde à ultrasons (1), et une distance parcourue par les tissus dans la direction parallèle à la surface frontale de la sonde à ultrasons (1) à partir du signal de résultat de détection de phase.
- 30
- 35
5. Appareil de diagnostic à ultrasons selon la revendication 1, dans lequel les moyens de commande de retard (3) comprennent des moyens pour changer la direction de ligne acoustique de l'émission et de la réception du faisceau d'impulsions d'ultrasons et du faisceau d'écho d'ultrasons pour scanner les parois artérielles dans le corps, les moyens de calcul de vitesse de tissus (7) comprennent des moyens pour calculer une vitesse des parois artérielles dans une direction d'une normale, une distance parcourue par les parois artérielles dans la direction de la normale, une vitesse des parois artérielles dans une direction d'une tangente, et une distance parcourue par les parois artérielles dans la direction de la tangente à partir du signal de résultat de détection de phase, et les moyens d'affichage (12) comprennent des moyens pour indiquer la vitesse calculée des parois artérielles dans la direction de la normale, la distance calculée parcourue par les parois artérielles dans la direction de la normale, la vitesse calculée des parois artérielles dans la direction de la tangente, et la distance calculée parcourue par les parois artérielles dans la direction de la tangente, comme des formes d'ondes.
- 40
- 45
6. Appareil de diagnostic à ultrasons selon la revendication 4, dans lequel les moyens d'affichage (12) comprennent des moyens pour indiquer une image du corps en mode B, et des moyens pour indiquer la vitesse calculée (Vx) des tissus dans la direction perpendiculaire à la surface frontale de la sonde à ultrasons (1), la distance calculée parcourue par les tissus dans la direction perpendiculaire à la surface frontale de la sonde à ultrasons (1), la vitesse calculée (Vz) des tissus dans la direction parallèle à la surface frontale de la sonde à ultrasons (1), et la distance calculée parcourue par les tissus dans la direction parallèle à la surface frontale de la sonde à ultrasons, sous forme de distributions de couleurs bidimensionnelles superposées sur l'image du corps en mode B.
- 50
- 55
7. Appareil de diagnostic à ultrasons selon la revendication 5, dans lequel les moyens d'affichage (12) comprennent

des moyens pour indiquer une image du corps en mode B, et des moyens pour indiquer la vitesse calculée des parois artérielles dans la direction de la normale, la distance calculée parcourue par les parois artérielles dans la direction de la normale, la vitesse calculée des parois artérielles dans la direction de la tangente, et la distance calculée parcourue par les parois artérielles dans la direction de la tangente, sous forme de distributions de couleurs bidimensionnelles superposées sur l'image du corps en mode B.

8. Appareil de diagnostic à ultrasons selon la revendication 6, dans lequel les moyens d'affichage (12) comprennent des moyens pour indiquer une forme d'ondes de la pression sanguine et un électrocardiogramme, superposés sur l'image du corps en mode B et sur les distributions de couleurs bidimensionnelles.

9. Appareil de diagnostic à ultrasons selon la revendication 7, dans lequel les moyens d'affichage (12) comprennent des moyens pour indiquer une forme d'ondes et de la pression sanguine et un électrocardiogramme, superposés sur l'image du corps en mode B et sur les distributions de couleurs bidimensionnelles.

10. Appareil de diagnostic à ultrasons selon la revendication 1, dans lequel les moyens d'émission et de réception comprennent :

des premiers moyens (1) pour émettre un premier faisceau d'impulsions d'ultrasons dans un corps en direction d'un objet à l'intérieur du corps le long d'une première direction ;

des seconds moyens (1) pour recevoir un premier faisceau d'écho d'ultrasons provoqué par réflexion du premier faisceau d'impulsions d'ultrasons sur l'objet et venant de l'objet le long de la première direction ;

des troisièmes moyens (1) pour émettre un second faisceau d'impulsions d'ultrasons dans le corps en direction de l'objet à l'intérieur du corps le long d'une seconde direction sous un angle différent de la première direction ; et

des quatrièmes moyens (1) pour recevoir un second faisceau d'écho d'ultrasons provoqué par réflexion du second faisceau d'impulsions d'ultrasons sur l'objet et venant de l'objet le long de la seconde direction ; et

dans lequel les moyens de calcul de vitesse des tissus comprennent :

des cinquièmes moyens (7) pour calculer une vitesse (V_x) de l'objet le long de la première direction à partir du premier faisceau d'écho d'ultrasons reçu par les seconds moyens (1), et

des sixièmes moyens (7) pour calculer une vitesse (V') de l'objet le long de la seconde direction à partir du second faisceau d'écho d'ultrasons reçu par les quatrièmes moyens (1).

11. Appareil de diagnostic à ultrasons selon la revendication 10, dans lequel la première direction est perpendiculaire à une surface du corps, et comprenant en outre des septièmes moyens (7) pour calculer une vitesse (V_z) de l'objet le long d'une troisième direction parallèle à la surface du corps à partir de la vitesse (V_x) calculée par les cinquièmes moyens (7), de la vitesse (V') calculée par les sixièmes moyens (7), et d'une différence angulaire (θ) entre la première direction et la seconde direction.

12. Appareil de diagnostic à ultrasons selon la revendication 10, comprenant en outre des septièmes moyens (7) pour calculer une direction de mouvement de l'objet à partir de la vitesse (V_x) calculée par les cinquièmes moyens (7), de la vitesse (V') calculée par les sixièmes moyens (7), et d'une différence angulaire (θ) entre la première direction et la seconde direction, et des huitièmes moyens (7) pour calculer une vitesse (V) de l'objet le long de la direction de mouvement calculée de l'objet à partir de la vitesse (V_x) calculée par les cinquièmes moyens (7), de la vitesse (V') calculée par les sixièmes moyens (7), et de la différence angulaire (θ) entre la première direction et la seconde direction.

FIG. 1

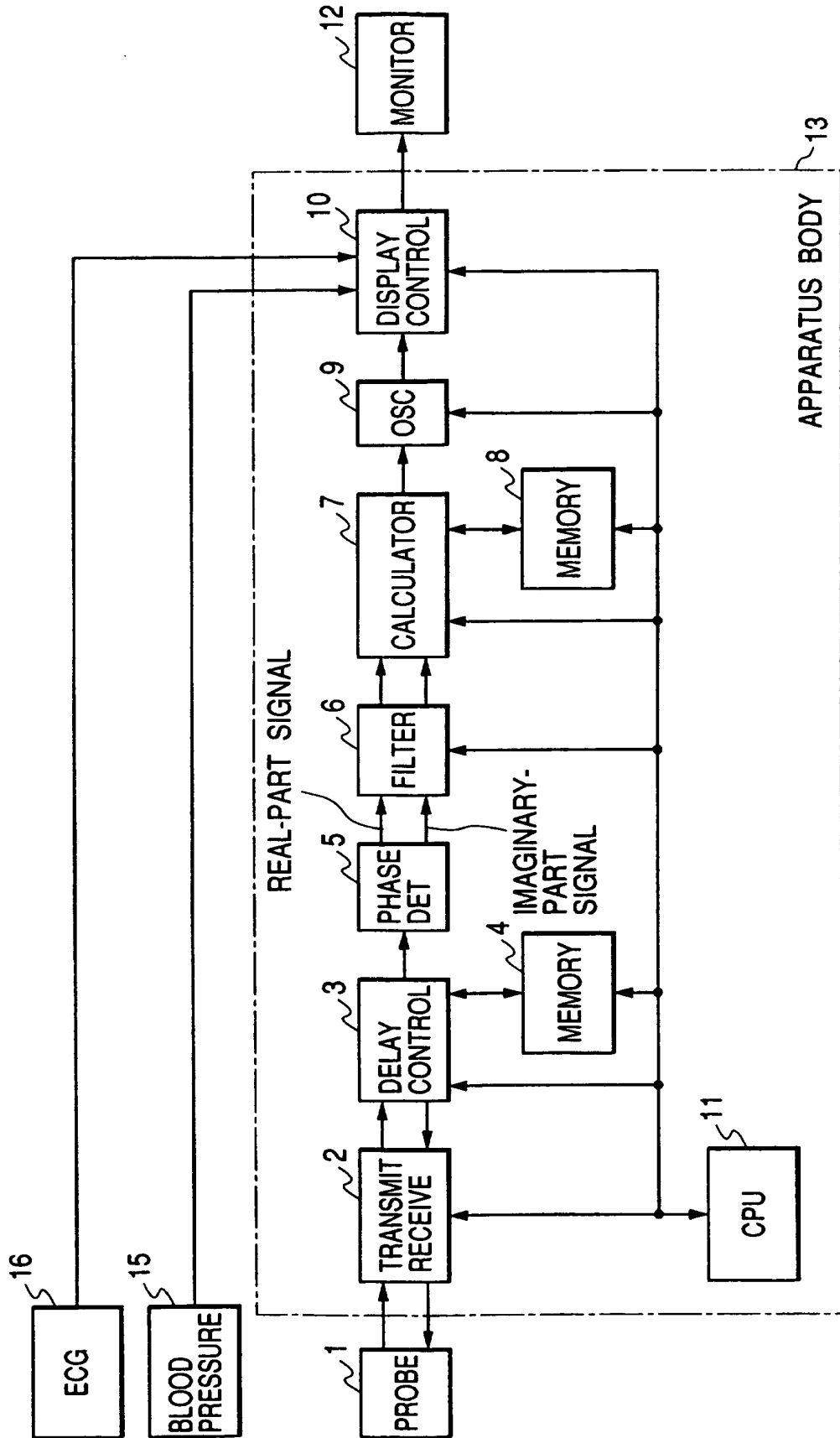

FIG. 2

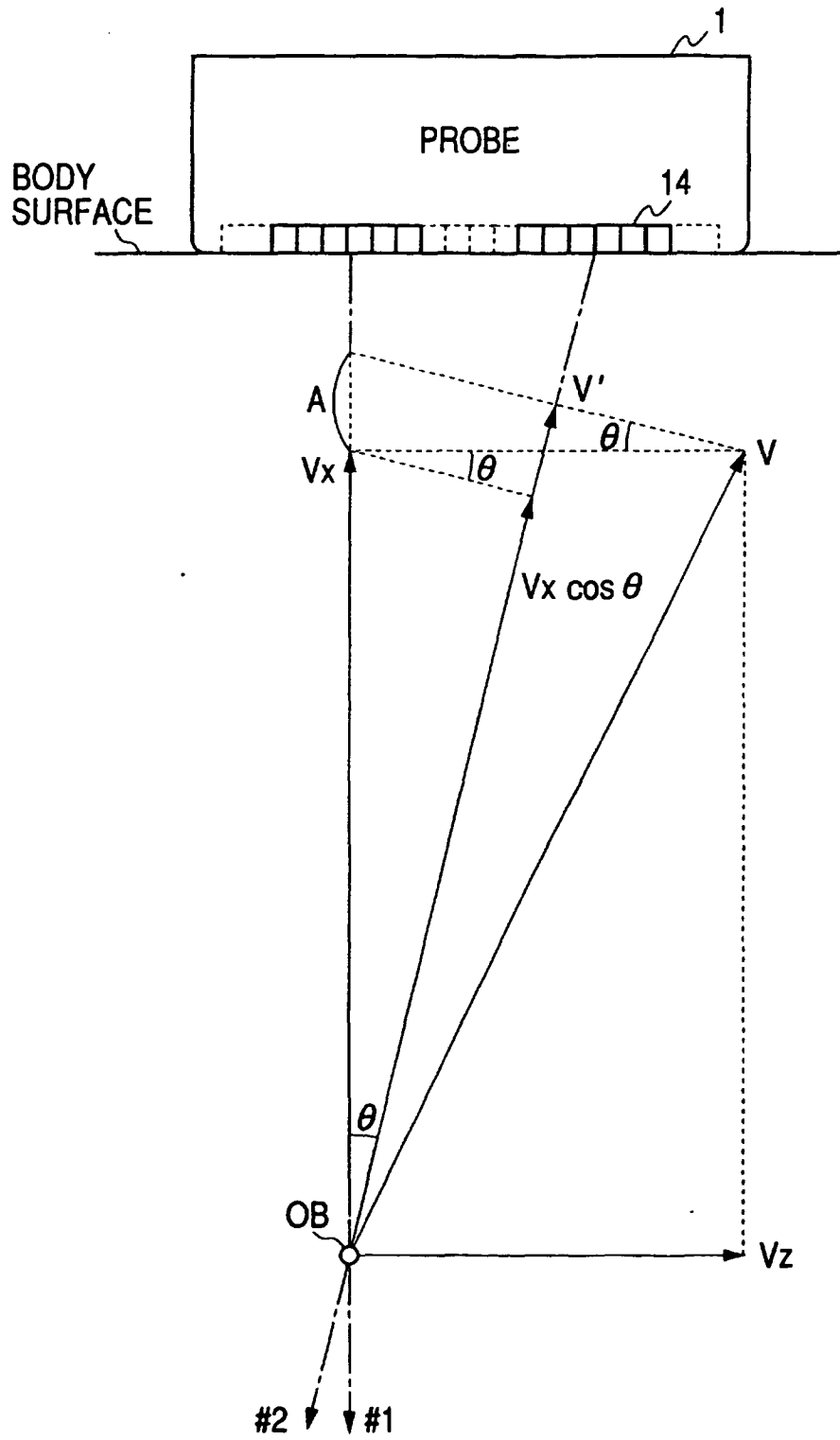

FIG. 3

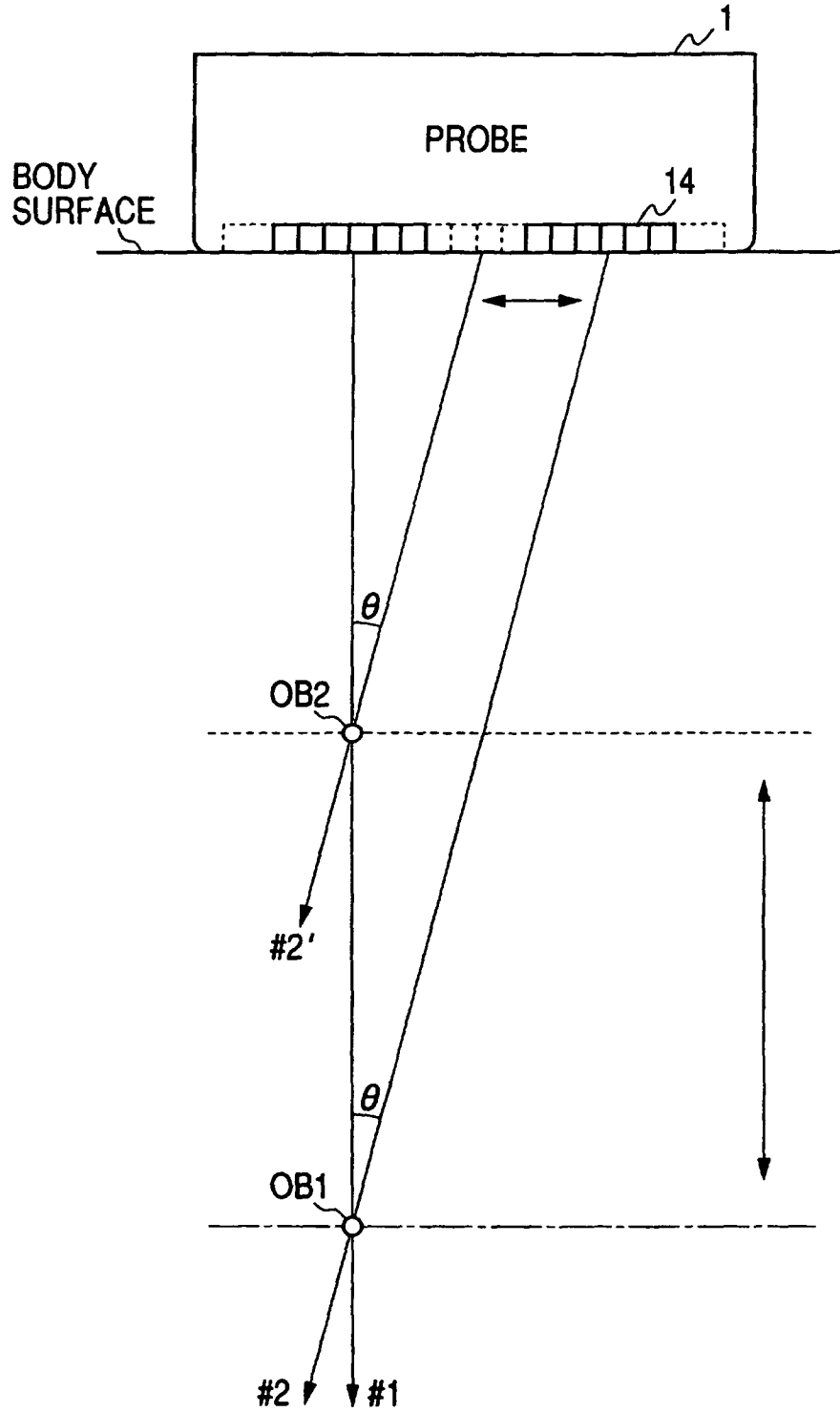

FIG. 5

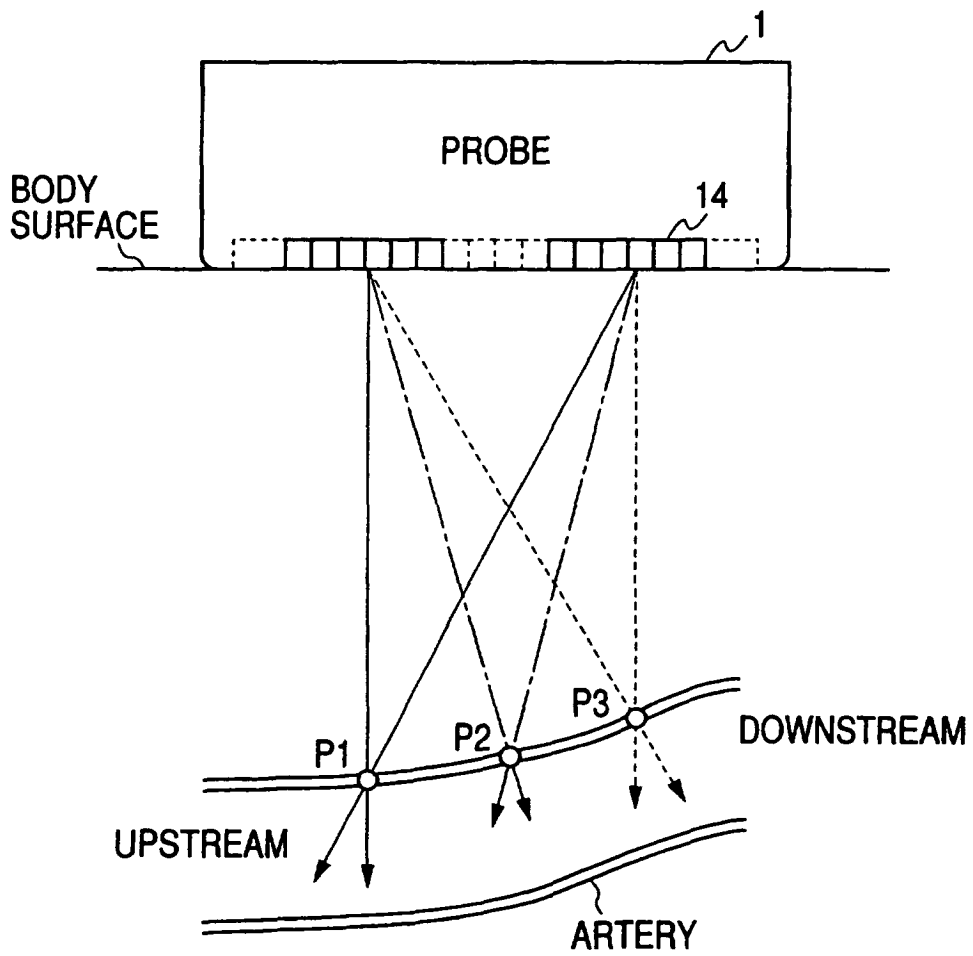

FIG. 6

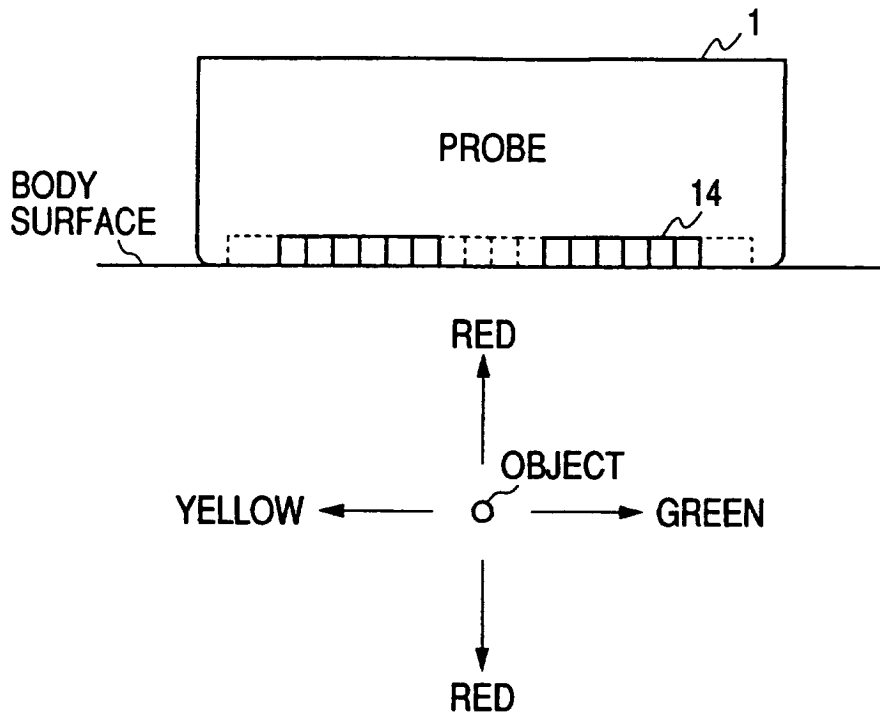
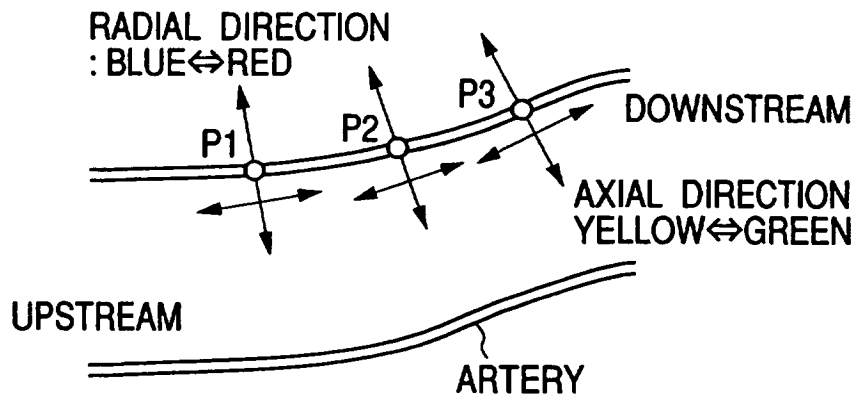
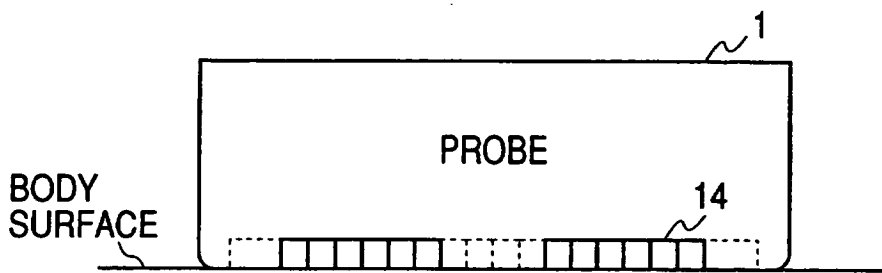

FIG. 7



REFERENCES CITED IN THE DESCRIPTION

This list of references cited by the applicant is for the reader's convenience only. It does not form part of the European patent document. Even though great care has been taken in compiling the references, errors or omissions cannot be excluded and the EPO disclaims all liability in this regard.

Patent documents cited in the description

- JP 9313485 A [0007] [0007] [0009]
- JP 10005226 A [0008] [0008] [0009]
- US 5910119 A [0011]

专利名称(译)	超声诊断仪		
公开(公告)号	EP1079242B1	公开(公告)日	2007-08-22
申请号	EP2000113591	申请日	2000-06-27
申请(专利权)人(译)	松下电器产业有限公司.		
当前申请(专利权)人(译)	松下电器产业有限公司		
[标]发明人	SUNAGAWA KAZUHIRO TANNAKA YOSHINAO KANAI HIROSHI		
发明人	SUNAGAWA, KAZUHIRO TANNAKA, YOSHINAO KANAI, HIROSHI		
IPC分类号	G01S15/58 A61B8/08 G01S15/89 A61B8/06		
CPC分类号	G01S15/8979 A61B8/488 G01S15/8984		
代理机构(译)	MANITZ , FINSTERWALD & PARTNER GBR		
优先权	1999237433 1999-08-24 JP		
其他公开文献	EP1079242A2 EP1079242A3		
外部链接	Espacenet		

摘要(译)

超声诊断设备包括具有超声探头的发送设备。发射装置用于将超声脉冲束从超声探头发射到身体中。接收设备包括超声探头。接收装置用于接收在体内引起的超声回波束，并通过超声探头将接收的超声回波束转换成相应的电回波信号。延迟控制装置用于控制超声脉冲束和超声回波束的发送和接收的声线方向。相位检测装置用于对电回波信号进行相位检测以产生相位检测结果信号。组织速度计算装置用于根据相位检测结果信号计算体内组织的速度。显示装置可操作用于指示计算的组织速度。延迟控制装置用于改变超声脉冲束和超声回波束相对于同一物体的发送和接收的声线方向。

$$V' = V_x \cos \theta \quad \dots (1)$$