



(12) **EUROPEAN PATENT APPLICATION**
published in accordance with Art. 158(3) EPC

(43) Date of publication:
26.05.2004 Bulletin 2004/22

(51) Int Cl.7: **A61B 8/08**

(21) Application number: **02760659.9**

(86) International application number:
PCT/JP2002/008348

(22) Date of filing: **19.08.2002**

(87) International publication number:
WO 2003/015635 (27.02.2003 Gazette 2003/09)

(84) Designated Contracting States:
DE FR NL

• **KOIWA, Yoshiro**
Aoba-ku, Sendai-shi, Miyagi 980-0866 (JP)

(30) Priority: **20.08.2001 JP 2001249398**

(74) Representative: **Panten, Kirsten et al**
Reichel & Reichel,
Patentanwälte,
Parkstrasse 13
60322 Frankfurt am Main (DE)

(71) Applicant: **Japan Science and Technology Agency**
Kawaguchi-shi, Saitama 332-0012 (JP)

(72) Inventors:
• **KANAI, Hiroshi**
Aoba-ku, Sendai-shi, Miyagi 981-0933 (JP)

(54) **TISSUE IDENTIFYING METHOD IN ULTRASONOGRAPHY AND ULTRASONOGRAPH**

(57) In a method for identifying a living tissue in an ultrasonic diagnosis, the elasticity of a living tissue to be diagnosed is measured for each local small area by using ultrasound. Elasticity data for each kind of known living tissue is composed of an elasticity modulus frequency histogram in each local small area for each kind of living tissue and is managed in a data library. Regarding the elasticity data serving as the measurement results, the kind of living tissue to be diagnosed is identified by using the elastic data for each kind of known living tissue.

FIG. 1

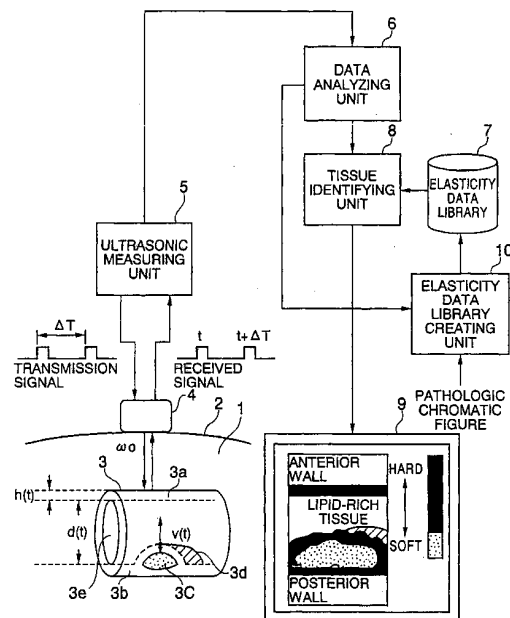

Description

Technical Field

[0001] This invention relates to a method for identifying a living tissue in an ultrasonic diagnosis and an ultrasonic diagnosis system, and more particularly to a method for identifying a living tissue in an ultrasonic diagnosis, in which ultrasound is used to carry out a diagnosis of a lesion on a living tissue according to a noninvasive measurement, and an ultrasonic diagnosis system, thereby the kind of tissue such as a lipid-rich (or fatty) area, a thrombus area, an elastic fiber, a collagen fiber, and a calcified area is identified and is displayed in an effective manner for a diagnosis of a local lesion such as an atheroma in a blood vessel.

Background Art

[0002] Until now myocardial infarction, angina pectoris, cerebral infarction, and so on have been considered to be the development of a stenosis on a blood vessel which perfuses organs. However, it has become evident that these diseases are caused by the susceptibility of an atheroma to rupture. The atheroma is a blood wall disease. Actually according to a clinical examination of a cholesterol-lowering agent used worldwide, the remarkable effect of improving a survival rate and preventing myocardial infarction is obtained even through the stenosis of a blood vessel hardly changes. This is because the agent stabilizes an atheroma as a tissue. In consideration of this fact, a method for examining the susceptibility of an atheroma to rupture (susceptibility to rupture) has been demanded. A conventional method such as X-ray CT, MRI, and angiography cannot carry out such an examination.

[0003] For example, in view of an accurate measurement on a blood vessel disease, conventional echocardiography M-mode just has a resolution of 1 mm. Similarly when the vibration of an aorta is determined as a displacement velocity by conventional Doppler method, conditions for accuracy are theoretically satisfied but the pulsation of a blood vessel greatly affects in reality. Thus, it is difficult to extract a small vibration superimposed to a relatively large amplitude. Hence, researchers including the inventor have developed a phased tracking method whereby a small vibration on a beating heart and a large blood vessel is remotely measured by ultrasound and an elasticity modulus of a blood vessel wall can be calculated on a given spot. Thus, it is possible to accurately diagnose the susceptibility of an atheroma to rupture (Reference Documents 1 to 5).

[0004] The following are reference documents:

1. Kanai H, Hasegawa H, Chubachi N, Koiwa Y, Tanaka M.

Noninvasive evaluation of local myocardial thickening and its color-coded Imaging. IEEE transaction

UFFC. 1997; 44: 752-768;

2. Hasegawa H, Kanai H, Hoshimiya N, Chubachi N, Koiwa Y.

Accuracy evaluation in the measurement of a small change in the thickness of arterial walls and the measurement of elasticity of the human carotid artery. Jpn J Appl Phys 1998; 37: 3101-3105;

3. Kanai H, Koiwa Y, J. Zhang

Real-time measurements of local myocardium motion and arterial wall thickening. IEEE-transaction UFFC. 1999; 46: 1229-1241;

4. Japanese Patent Laid-Open No. 10-5226; and

5. Japanese Patent Laid-Open No. 12-229078.

[0005] The phased tracking method will be schematically described below. The phased tracking method is a new bioinstrumentation for measuring a small vibration velocity on a cardiac wall and a blood vessel wall. This method makes it possible to accurately measure a vibration of 500 Hz or less and 0.01 mm and a change of 10 microns on a wall. With this method, for example, small velocities on a plurality of measurement points between the layer (or layers) in the arterial wall or on the wall of an arterial vessel are determined by ultrasonic Doppler method, and the small velocities on the measurement points are subjected to time quadrature, so that a time change in the positions of the measurement points can be calculated. Since a change in layer thickness can be determined by the time change in the positions of the measurement points, the elasticity modulus of the layer can be obtained, thereby estimating susceptibility to rupture.

[0006] Actually as shown in FIG. 17, an arterial intramural measurement point on an ultrasonic beam 91 is set at (i) and a measurement point with the subsequent depth is set at (i+1). Small vibration velocities $v_i(t)$ and $v_{i+1}(t)$ on the measurement points are determined and a difference between the small vibration velocities is subjected to time quadrature, so that a change $\Delta h(t)$ in layer thickness between the measurement points (i) and (i+1) in the arterial wall is determined. Reference numeral 92 denotes a plaque.

$$\Delta h(t) = \int_{-\infty}^t \{v_i(t) - v_{i+1}(t)\} dt$$

[0007] The simplest method for converting the change into an elasticity value for each layer in the arterial wall is performed as follows: a wall thickness is set at h_d and a change in thickness is set at Δh at the lowest blood pressure where a wall thickness increases, a pulse pressure at a cuff pressure on brachial artery is set at ΔP , and a wall elasticity modulus is measured for each layer in the following manner.

[0008] Based on a thickness change (Δh) of each layer from the intima to the adventitia of a blood vessel, an

elasticity value (E_n) of each small part (n) in a blood vessel wall atheroma is determined by the formula below.

$$E_n = (\Delta P / (\Delta h / h d)) n$$

[0009] With this phased tracking method, it is possible to measure an elasticity value for each layer along the depth direction in a blood vessel wall approximately every 0.75 mm to 0.075 mm on an ultrasonic beam, thereby displaying a tomogram based on the elasticity values.

[0010] In a clinical diagnosis using the phased tracking method, when an elasticity value is examined for each layer of a blood vessel wall, the elasticity value ranges from 100 to 2 MPa in a normal person. However, in the example of an atheroma, elasticity values are not evenly distributed. It is understood that fundamentally a physically soft portion is present in a thrombus and is covered with a hard portion. In addition, various patterns are present in the tomogram of an atheroma. For example, an extremely soft substance is exposed on the lumen of a blood vessel without continuity on a capsule of a hard surface, and a substance having a large elasticity value almost entirely covers a surface. Elasticity values in an atheroma are distributed from 0 to 4 MPa. Further, according to the examination results on the correspondence of a lipid-rich layer and a collagen fiber in an extracted blood vessel and elasticity values in the phased tracking method, there is a probability that the tissue image of a collagen fiber covering an atheroma can be separately displayed from a tomogram of elasticity values, the tomogram being obtained in a noninvasive manner.

[0011] It is an object of the present invention to provide more specific information displayed in a tomogram and to identify the kind of living tissue such as a lipid-rich area, a thrombus area, an elastic fiber, a collagen fiber, and a calcified area in an ultrasonic diagnosis of a living tissue such as a lesion on a blood vessel.

[0012] It is another object of the present invention to identify the kind of living tissue such as a lipid-rich area, a thrombus area, an elastic fiber, a collagen fiber, and a calcified area by using a shear elasticity modulus and a shear viscosity in an ultrasonic diagnosis of a living tissue such as a lesion on a blood vessel.

Disclosure of Invention

[0013] A method for identifying a living tissue in an ultrasonic diagnosis and an ultrasonic diagnosis system according to the present invention are realized in the following structures.

[0014] The method for identifying a living tissue in an ultrasonic diagnosis according to the present invention includes measuring at least the elasticity of a living tissue to be diagnosed in each local small area by using ultrasound; managing, in a data library, at least elasticity data for each kind of known living tissue, the elasticity

data being composed of an elasticity modulus frequency histogram in each local small area for each kind of living tissue; and identifying the kind of living tissue to be diagnosed, at least regarding the elasticity data serving as measurement results, by using the elasticity data for each kind of known living tissue.

[0015] Further, the method for identifying a living tissue in an ultrasonic diagnosis preferably includes exciting a vibration on a measured part of the living tissue to be diagnosed; measuring a shear elasticity and a shear viscosity of the excited living tissue to be diagnosed in the measurement using ultrasound; managing viscosity data for each kind of known living tissue in the management of the data library, the viscosity data being composed of a viscosity frequency histogram in each local small area for each kind of living tissue; and identifying the kind of living tissue to be diagnosed, regarding the elasticity data and viscosity data serving as measurement results, by using the elasticity data and viscosity data for each kind of known living tissue in the identification of the kind of living tissue to be diagnosed.

[0016] Further, the method for identifying a living tissue in an ultrasonic diagnosis according to the present invention, wherein the vibration on the measured part of the living tissue to be diagnosed is preferably excited by a turbulent flow component or a vortex component, the components being generated by a time change in a pulse of a pulsatile flow in a blood vessel.

[0017] Moreover, the method for identifying a living tissue in an ultrasonic diagnosis according to the present invention, wherein the vibration on the measured part of the living tissue to be diagnosed is preferably excited by a vibration percutaneously applied to a part away from the measured part from the outside of a body.

[0018] Additionally, the method for identifying a living tissue in an ultrasonic diagnosis according to the present invention, wherein in the management of the data library, each kind of known living tissue is preferably mapped on a two-dimensional plane having axes representing a shear elasticity modulus and a shear viscosity.

[0019] Besides, the method for identifying a living tissue in an ultrasonic diagnosis according to the present invention, wherein the living tissue to be diagnosed is preferably a living tissue on a heart, a blood vessel, and so on.

[0020] Further, the method for identifying a living tissue in an ultrasonic diagnosis according to the present invention, wherein the kind of known living tissue preferably includes a lipid-rich area, a thrombus area, an elastic fiber, a collagen fiber, and a calcified fiber.

[0021] Moreover, the method for identifying a living tissue in an ultrasonic diagnosis according to the present invention, wherein the local small area serving as a unit to measure the elasticity of the living tissue to be diagnosed is preferably several tens to several hundreds square microns.

[0022] Besides, the method for identifying a living tissue in an ultrasonic diagnosis according to the present invention, wherein the kind of living tissue to be diagnosed is identified using the elasticity data serving as measurement results, and the identification is preferably performed by referring to the elasticity data for each kind of known living tissue, the data being extracted from the data library, and determining the kind of known living tissue having the minimum distance.

[0023] Moreover, the method for identifying a living tissue in an ultrasonic diagnosis according to the present invention, wherein the kind of known living tissue having the minimum distance from the elasticity data serving as measurement results is preferably determined by using Bayes decision method for dispersion and an average value of the elasticity moduli determined from the histogram of elasticity data on each kind of known living tissue.

[0024] Additionally, the method for identifying a living tissue in an ultrasonic diagnosis according to the present invention, wherein an electronic chromatic figure is preferably generated and displayed so as to identify in colors the kind of living tissue to be diagnosed, the kind of living tissue being identified for each local small area.

[0025] An ultrasonic diagnostic system of the present invention, in which at least the elasticity of a living tissue to be diagnosed is measured for each local small area by using ultrasound and a tomogram is displayed, the system includes a data library for managing at least elasticity data in each kind of known living tissue, the elasticity data being composed of an elasticity modulus frequency histogram in each local small area for each kind of living tissue, and a tissue identifying unit to identify the kind of living tissue to be diagnosed, regarding at least the elasticity data serving as measurement results, by using the elasticity data for each kind of known living tissue.

[0026] Further, the ultrasonic diagnostic system preferably includes exciting means for exciting a vibration on a measured part of a living tissue to be diagnosed, wherein the data library further includes viscosity data for each kind of known living tissue and manages the viscosity data for each kind of known living tissue, the viscosity data being composed of a viscosity frequency histogram in each local small area for each kind of living tissue, and the tissue identifying unit identifies the kind of living tissue to be diagnosed, regarding the elasticity data and viscosity data serving as measurement results of the excited living tissue to be diagnosed, by using the elasticity data and viscosity data for each kind of known living tissue.

[0027] Moreover, the ultrasonic diagnostic system of the present invention, wherein each kind of known living tissue is preferably mapped on a two-dimensional plane having axes representing a shear elasticity modulus and a shear viscosity.

[0028] Besides, the ultrasonic diagnostic system of

the present invention, wherein the living tissue to be diagnosed is preferably a living tissue on a heart, a blood vessel, and so on.

[0029] Additionally, the ultrasonic diagnostic system of the present invention, wherein the kind of known living tissue preferably includes a lipid-rich area, a thrombus area, an elastic fiber, a collagen fiber, and a calcified fiber.

[0030] Further, the ultrasonic diagnostic system of the present invention, wherein the local small area serving as a unit to measure the elasticity of the living tissue to be diagnosed is preferably several tens to several hundreds square microns.

[0031] Moreover, the ultrasonic diagnostic system of the present invention, wherein the tissue identifying unit preferably has identifying means which refers to the elasticity data for each kind of known living tissue, the data being extracted from the data library, and determines the kind of known living tissue having the minimum distance, for each elasticity data serving as measurement results in each local small area.

[0032] Besides, the ultrasonic diagnostic system of the present invention, wherein the identifying means preferably determines dispersion and an average value of the elasticity moduli from the histogram of elasticity data of each kind of known living tissue, the data being extracted from the data library, and the identifying means performs identification using Bayes decision method.

[0033] Additionally, the ultrasonic diagnostic system of the present invention, wherein the tissue identifying unit has electronic chromatic figure generating means for generating an electronic chromatic figure so as to identify in colors the kind of living tissue to be diagnosed, the kind of living tissue being identified for each local small area.

Brief Description of Drawings

[0034]

FIG. 1 is a schematic structural diagram showing an ultrasonic diagnostic system according to the present invention.

FIG. 2 is an explanatory drawing showing the generation of an elasticity modulus tomogram, and especially FIG. 2A shows one scanning position of an ultrasonic beam, FIG. 2B shows the calculation of displacement waveforms, FIG. 2C shows a thickness change waveform, FIG. 2D shows an elasticity modulus tomogram, and FIG. 2E shows the overall flow of the generation of an elasticity modulus tomogram.

FIG. 3 is a schematic diagram showing the creation of an elasticity data library.

FIG. 4 is a flow showing tissue identification.

FIG. 5 is a diagram showing the measurement results of elasticity moduli of a fiber tissue.

FIG. 6 is a diagram showing an example of tissue identification (71-year-old man).

FIG. 7 is a diagram showing an example of tissue identification (52-year-old man).

FIG. 8 is a schematic structural diagram showing another ultrasonic diagnostic system according to the present invention.

FIG. 9 is a conceptual drawing showing a vibration excited on a blood vessel wall.

FIG. 10 is a conceptual drawing showing a vibration excited on a blood vessel wall.

FIG. 11 is a diagram showing an example of a waveform of a small vibration velocity $v(t)$ on a blood vessel wall.

FIG. 12 is a diagram showing a power spectrum obtained by frequency analysis.

FIG. 13 is a diagram showing a tomogram, and especially FIG. 13A shows a tomogram of attenuation, and FIG. 13B shows a tomogram of a phase velocity.

FIG. 14 is a diagram showing a tomogram, and especially FIG. 14A shows a tomogram of a shear elasticity modulus, and FIG. 14B shows a tomogram of a shear viscosity.

FIG. 15 is a diagram showing an example of the data library where tissues are mapped on a two-dimensional plane.

FIG. 16 is a conceptual drawing showing an example of a tomogram having undergone electronic dyeing, and

FIG. 17 is a diagram showing an image of elasticity modulus distribution of an atheroma on a carotid wall.

Best Mode for Carrying Out the Invention

[Embodiment 1]

[0035] In this example, the conventional problem is solved as follows: based on findings that tissues such as a lipid-rich area, a thrombus area, an elastic fiber, a collagen fiber, and a calcified area that are found on a blood vessel wall are different in hardness according to tissue characteristics, the frequency distribution (histogram) concerning an elasticity value for each kind of tissue is acquired beforehand and is managed in a data library, each local elasticity value obtained in an ultrasonic diagnosis is compared with the frequency distribution of the elasticity values of the tissues in the data library, a tissue is discriminated by determining the tissue having a frequency distribution of the closest elasticity value, and tissue type information is displayed, for example, in colors in a tomogram.

[0036] FIG. 1 is a schematic structural diagram showing an ultrasonic diagnostic system according to the present invention.

[0037] In FIG. 1, reference numeral 1 denotes a human body, reference numeral 2 denotes the surface of

the body, and reference numeral 3 denotes a blood vessel including an artery to be measured. In the blood vessel, a blood vessel wall has a thickness of $h(t)$, a lumen has a diameter of $d(t)$, and a vibration is made at a movement velocity of $v(t)$. Reference numeral 3a denotes the anterior wall of the blood vessel. Reference numeral 3b denotes the posterior wall of the blood vessel. Reference numeral 3c denotes a lesion such as an atheroma appearing in the blood vessel 3. Reference numeral 3d denotes a lipid-rich tissue. Reference numeral 3e denotes the lumen of the blood vessel 3. Reference numeral 4 denotes an ultrasonic probe which can change the emitting direction of an ultrasonic beam to perform scanning over a certain range. Reference numeral 5 denotes an ultrasonic measuring unit which generates a transmission signal with an angular frequency of ω_0 at a fixed time interval ΔT to drive the ultrasonic probe 4 and radiates an ultrasonic beam to the blood vessel 3. When the ultrasonic probe 4 receives a reflected wave from the blood vessel 3, the received signal of the probe is subjected to quadrature demodulation and AD conversion and a detection signal is outputted in a digital signal format.

[0038] Reference numeral 6 denotes a data analyzing unit. The data analyzing unit 6 analyzes the detection signal, which has been outputted in a digital signal format from the ultrasonic measuring unit 5, according to phased tracking method, performs tracking on the track of the large amplitude displacement of the blood vessel 3, and determines a small vibration velocity of each reflection point on the surface of the blood vessel wall and between layers on the track. According to the result, a time change is calculated for the thickness of the blood vessel wall or each of the layers. An elasticity modulus of a tissue on the blood vessel wall or each of the layers is accurately calculated based on the time change in each small area determined by a resolving power, and elasticity modulus tomogram data is generated. In this tracking, the displacing motion of a small vibration in the layers of the blood vessel is analyzed under the constraint that a cumulative displacement in a pulse is set at 0 so as to make a return to the original position at each pulse of the heart, thereby stabilizing an image.

[0039] Reference numeral 7 denotes an elasticity data library used as the reference (a kind of dictionary) of tissue identification. The elasticity data library 7 stores elasticity data concerning kinds of living tissues. The data has been inputted beforehand and serves as the reference. To be specific, the elasticity data library 7 stores frequency distribution (histogram) data concerning an elasticity value of each kind of known living tissue. Further, an average value and dispersion may be calculated from the frequency distribution data and may be replaced with the frequency distribution.

[0040] Reference numeral 8 denotes a tissue identifying unit, in which regarding an elasticity value on each point of the elasticity modulus tomogram data generated by the data analyzing unit 6, the elasticity data concern-

ing various kinds of living tissues is extracted from the elasticity data library 7, the elasticity data serving as the reference, a comparison is made, the closest kind of living tissue is discriminated, and electronic chromatic figure data is generated. In the electronic chromatic figure data, the area of the elasticity modulus tomogram is displayed in colors corresponding to the kinds of tissues.

[0041] Reference numeral 9 denotes a display device which displays an electronic chromatic figure based on the electronic chromatic figure data generated by the tissue identifying unit 8.

[0042] Reference numeral 10 denotes an elasticity data library creating unit, in which regarding data effectively acting as the reference in the elasticity modulus tomogram data generated by the data analyzing unit 6, a comparison is made with a pathologic chromatic figure generated in advance, so that the kind of living tissue is identified in each local area of the tomogram, and attribute data indicating the kind of living tissue is inputted and set in the elasticity modulus tomogram data. Then, attribute data in each local area is examined, and the frequency distribution of an elasticity modulus is determined for each kind of living tissue and is registered in the elasticity data library 7.

[0043] The embodiment of the ultrasonic diagnostic system shown in FIG. 1 will be discussed in detail below.

[0044] FIG. 2E shows the overall flow of the generation of an elasticity modulus tomogram that corresponds to conventional processing performed by the ultrasonic measuring unit 5 and the data analyzing unit 6 of FIG. 1. As shown in FIG. 2 A, a blood vessel area to be diagnosed on a living tissue is scanned by the ultrasonic probe along an arrow S, an ultrasonic pulse is transmitted at each scanning position (beam position P) at a regular interval (step S11), and reflected waves are collected from the anterior wall and posterior wall of a blood vessel and boundaries between the layers of the blood vessel (step S12). Step S11 and step S12 are repeated by the ultrasonic measuring unit 5 at each scanning position of an ultrasonic beam position.

[0045] Subsequently, data of the reflected waves collected by the data analyzing unit 6 is analyzed. First, as shown in FIG. 2B, regarding points (indicated by circles) on the surface of the blood vessel wall and boundaries between the layers of the blood vessel on one beam, displacement waveforms are calculated and tracking is performed to track the large amplitude motion generated on the blood vessel by heart stroke (step S13). Step S13 is repeated on all the points of one beam. Then, between adjacent points of FIG. 2A, a thickness change waveform is calculated as shown in FIG. 2C (step S14). In this example, at the largest diameter of the lumen in FIG. 2B, a thickness change in FIG. 2C has the maximum value Max, which indicates the smallest thickness. The maximum value of the thickness change in a pulse is calculated (step S15). By using the value and a difference between the maximum blood pressure and the minimum blood pressure of a cuff pressure measured

on an upper arm, a local elasticity modulus is calculated (step S16). Steps S14 to S16 are repeated on all the points. When local elasticity moduli are calculated for layers between all the adjacent points on one beam scanning position (step S17), a shift is made to the subsequent beam scanning position, steps S13 to S17 are repeated, and local elasticity moduli are similarly calculated for layers between all the adjacent points. In this way, local elasticity moduli are calculated on all the beam scanning positions and an elasticity modulus tomogram is calculated, in which the local elasticity modulus of a diagnostic area is indicated by a pixel value or a color attribute as shown in FIG. 2D (step S18).

[0046] FIG. 3 is a schematic diagram showing the generation of the elasticity data library that corresponds to the processing of the elasticity data library creating unit 10 shown in FIG. 1. In the generation of the elasticity data library, regarding a suitable living tissue to be used as the reference of tissue identification, an area of an elasticity modulus tomogram is classified for each kind of tissue, and the frequency distribution (histogram) of an elasticity modulus is calculated for each kind of tissue and is registered in the elasticity data library. Hence, an ultrasonic measurement part, that is the elasticity modulus tomogram calculated by the flow of FIG. 2 is displayed on a screen (step S21) and another sample tissue is compared with an actual chromatic figure, in which a specific kind of tissue is dyed by pathologic dyeing, so that each kind of tissue area is identified in the elasticity modulus tomogram and area specification is performed on each kind of tissue (step S22). The example of FIG. 3 has five kinds of tissues including a lipid-rich area, a thrombus area, an elastic fiber, a collagen fiber, and a calcified area. In this way, after the setting of an area for each kind of tissue required for the elasticity modulus tomogram, the frequency distribution of an elasticity modulus is calculated for each resolution area such as a pixel in each area for each kind of tissue (step S22) and the results are registered in the elasticity data library (step S23).

[0047] FIG. 4 shows the flow of tissue identification that corresponds to the processing of the tissue identifying unit 8 shown in FIG. 1. In tissue identification, the following processing is repeated: on each point of the elasticity modulus tomogram of a measured living body, the elasticity modulus is classified to the closest kind of tissue with reference to elasticity modulus frequency distribution data of tissues registered in the elasticity data library. In this example, Bayes decision method (Bayes classification method) is used as a mathematical method for tissue identification. Bayes decision method is one of statistical estimation methods. In this method, regarding the frequency distribution of a kind of tissue that is most likely to have an elasticity modulus on one point of the elasticity modulus tomogram, an estimation is made so that a defined loss function has the minimum expected value. This estimation corresponds to the selection of a similar pattern of the minimum distance in

pattern recognition.

[0048] First, the elasticity modulus tomogram of a measured living body is determined by the processing of FIG. 2 (step S31). On the other hand, from the elasticity data library generated based on the calculation of the elasticity modulus tomogram (step S36) in the processing of FIG. 3, elasticity modulus frequency distribution data is read regarding five kinds including a lipid-rich area, which serves as a candidate of tissue classification, and an average value and dispersion are calculated for each elasticity modulus distribution (Step S37). Then, elasticity moduli on the points of the elasticity modulus tomogram are sequentially extracted (step S32), Bayes decision is performed by using values determined in step S37 (step S33), and the elasticity modulus is classified as a minimum-distance tissue in processing results (step S34). Steps S32 to S34 are repeated on all the points of the elasticity modulus tomogram. In this way, an elasticity modulus on each point of the elasticity modulus tomogram is classified as a proper tissue and an electronic chromatic figure is generated (step S35).

[0049] Subsequently, FIGS. 5, 6, and 7 show the examples of actual measurements.

[0050] In FIG. 5, reference numerals 51 to 53 denote the examples of elasticity modulus measurement results of a fibrous tissue. An image 51 on the left shows an elasticity modulus tomogram and an image 52 shows the tomogram of a fibrous tissue. A graph 53 on the right shows the histogram of a fibrous tissue. In FIG. 5, reference numerals 54 to 56 denote the examples of elasticity modulus measurement results of a lipid-rich tissue. An image 54 on the left shows an elasticity modulus tomogram and an image 55 shows the tomogram of a lipid-rich tissue. A graph 56 on the right shows the histogram of a lipid-rich tissue.

[0051] FIGS. 6 and 7 show tissue discrimination examples of a 71-year-old man and a 52-year-old man. In FIGS. 6 and 7, reference numerals 61 and 71 denote B-mode images, reference numerals 62 and 72 denote elasticity modulus tomograms, reference numerals 63 and 73 denote the tomograms of a lipid-rich tissue, reference numerals 64 and 74 denote the tomograms of a fibrous tissue, and reference numerals 65 and 75 denote the electronic chromatic figures of a tissue.

[Embodiment 2]

[0052] In this example, the conventional problem is solved as follows: based on findings that tissues such as a lipid-rich area, a thrombus area, an elastic fiber, a collagen fiber, and a calcified area that are found on a blood vessel wall are different in viscosity in addition to hardness according to each tissue characteristic, the frequency distribution (histogram) of viscosity in addition to an elasticity value for each kind of tissue is acquired beforehand and is managed in a data library, each local elasticity value and viscosity value that are

obtained in an ultrasonic diagnosis are compared with the frequency distribution of the elasticity values and viscosity values of the tissues in the data library, a tissue is discriminated by determining a tissue having a frequency distribution of the closest elasticity value and viscosity, and tissue type information is displayed, for example, in colors in a tomogram.

[0053] A motion such as the pulsation of a living tissue and a change in intravascular pressure have a low frequency band of 30 Hz or less. Thus, when a motion such as the pulsation of a living tissue and a change in intravascular pressure serve as external forces applied to a tissue, a measurement is considered to be static, though an amplitude is large. In the case of such a static measurement, it is necessary to measure a deformation of a tissue before and after a change in pressure and calculate an elasticity modulus by the calculation of (pressure change)/(distortion), (so called static technique). However, in reality, it is difficult to measure a pressure applied inside and a change in pressure in vivo.

[0054] Hence, the following method is proposed: a low-frequency sine wave oscillation (generally a single frequency component) is applied from the outside by using an oscillator and so on, the propagation velocity of a vibration (shear elasticity) is measured in vivo, and a parameter for a hardness of a tissue is calculated (external oscillation + dynamic method, Jpn J. Med Ultrasonics, Vol. 16, No. 3, pp. 221-229, 1989). In this method, it is not necessary to measure a pressure and a change in pressure. When a blood vessel wall is oscillated, although a bending oscillation can be readily excited so as to entirely bend a blood vessel wall, it is difficult to propagate a vibration so as to penetrate the wall from the outside to the inside of the blood vessel wall.

[0055] Hence, the present invention focuses attention on a fact that components such as a "turbulent flow" and a "vortex" that are generated by a time change in a pulse of a pulsatile flow in a blood vessel "excite vibrations of components over a wide frequency band of several tens Hz to several hundreds Hz on a blood vessel wall with a small amplitude of several mm/s or less." The wall vibration is accurately measured by using ultrasound and a waveform is analyzed, so that a propagation velocity and a propagation loss of a vibration (shear elastic wave) in vivo can be calculated at each frequency f.

[0056] Besides, (1) the vibrations excited by the "turbulent flow" and the "vortex" are small in amplitude (several mm/s or less) and (2) the position of the wall is moved by about several mm due to the arrival of pulsation. Thus, measurement could not be performed in vivo.

[0057] For example, in a conventional ultrasonic Doppler measurement technique, an average blood flow velocity of an area (several mm width) set in the lumen of a blood vessel is measured by frequency analysis on ultrasound reflected in a blood flow or correlation method. However, a target velocity in a blood flow measurement is several tens cm/s, which is larger than the vibration velocity of a blood vessel wall by two digits or

more. Although the momentary magnitude of a blood flow velocity is considered important in a diagnosis, the waveform of the obtained blood flow velocity was not subjected to waveform analysis (frequency analysis) and so on.

[0058] In this example, an ultrasonic measurement method invented by the inventor (Japanese Patent Laid-Open No. 8-163418, U.S. Patent No. 5,840,028) is adopted. With this method, a waveform with a small vibration velocity generated by pulsation on an arterial wall can be measured by using ultrasound. In the present invention, a waveform of wall vibration is measured by the ultrasonic measurement method simultaneously on a plurality of points set at intervals of several hundreds microns from the intima to the adventitia of a blood vessel wall on one ultrasonic beam.

[0059] FIG. 8 shows a schematic structural diagram showing another ultrasonic diagnostic system according to the present invention.

[0060] FIG. 8 shows that the ultrasonic diagnostic system is further provided with a data library 7A instead of the elasticity data library 7, a data library creating unit 10A instead of the elasticity data library creating unit 10, and exciting means 11, in the structure of FIG. 1.

[0061] In addition to the elasticity data, the data library 7A stores viscosity data of living tissues that serves as previously inputted reference data, that is frequency distribution (histogram) data of a viscosity value for each kind of known living tissue.

[0062] In addition to the elasticity data, the data library creating unit 10A registers the frequency distribution of a viscosity for each kind of living tissue. That is, regarding data effectively acting as the reference data in viscosity tomogram data generated by a data analyzing unit 6, a comparison is made with a previously generated pathologic chromatic figure, so that the kind of living tissue is identified in each local area of the tomogram, and attribute data indicating the kind of living tissue is inputted and set in the viscosity tomogram data. Then, attribute data of each local area is examined, the distribution frequency of viscosities is obtained for each kind of living tissue, and the frequency distribution is registered in the data library 7A.

[0063] The embodiment of the ultrasonic diagnostic system of FIG. 8 will be described in detail. The following explanation will mainly discuss differences from Embodiment 1.

[0064] In accordance with the processing flow of FIG. 2E, for example, a waveform with a small vibration velocity $v(t)$ that is generated on an arterial wall due to pulsation is measured (steps S11 to S13) by using the ultrasonic measurement method above-described (U.S. Patent No. 5,840,028, which is incorporated by a reference in this specification). Thus, a waveform of wall vibration is measured simultaneously on a plurality of points set at intervals of several hundreds microns from the intima to the adventitia of a blood vessel wall on one ultrasonic beam. The amplitude is several mm/s or less

and the frequency is a band of 0 Hz to several hundreds Hz.

[0065] At the measurement, as shown in FIG. 9, a pulse wave 11a caused by pulsation propagates through a lumen 3e of a blood vessel 3 and a lesion 3c causes a turbulent flow 11b or a vortex 11c. The turbulent flow 11b and the vortex 11c, each serving as a vibration source, vibrate the wall of the blood vessel 3 in the above-described manner. Thus, a vibration $v(t)$ is measured on each point (white circle) by an ultrasonic beam B. Reference numeral 3f denotes the adventitia of the blood vessel wall. Reference numeral 3g denotes the intima of the blood vessel wall. The measured vibration $v(t)$ is shown in FIG. 11. FIG. 11 shows measurement results in a period of four pulses. It is found that each point vibrates according to pulsation.

[0066] A pulse wave 11a may be generated by pulsation. That is, any structure is applicable as long as an inner product is changed by excited bending oscillation (of blood vessel 3) and thus an internal pressure change $\Delta P(f)$ is excited as shown in FIG. 10B. Reference character "f" denotes a frequency at which a vibration source vibrates. The inner pressure change $\Delta P(f)$ propagates as the pulse wave 11a. Therefore, for example, a vibration on a measured part 3h (FIG. 10) is excited by the component of the turbulent flow 11b or the vortex 11c which are generated by a time change in a pulse of a pulsatile flow in the blood vessel 3.

[0067] Further, as shown in FIG. 10A, the pulse wave 11a may be generated by the exciting means 11. The vertical vibration of the exciting means 11 at the frequency "f" excites the internal pressure change $\Delta P(f)$. Therefore, for example, the vibration on the measured part 3h is excited by a vibration percutaneously applied to a part away from the measured part 3h from the outside of the body.

[0068] Moreover, instead of steps S14 to S16 of FIG. 2E, waveforms are cut out at the same timing in a pulse and frequency analysis is performed (while a window is applied in a diastole), so that a transfer function $H(f)$ from a vibration waveform $v_m(t)$ at m point on the intima to a vibration waveform $v_n(t)$ at n-th point of the adventitia is calculated. That is, the power spectrum of FIG. 12 is obtained by the frequency analysis. When a distance is d between the two points in the power spectrum, an attenuation constant $\alpha(f) = |H(f)|/d$ associated with propagation between the two points can be calculated from an amplitude $|H(f)|$. Moreover, a phase velocity $v(f) = 2\pi f / (\angle H(f)/d)$ of propagation between the two points can be calculated from a phase $\angle H(f)$ of the transfer function.

[0069] A tomogram on the attenuation of FIG. 13A can be obtained from the attenuation constant $\alpha(f)$. Further, a tomogram of the phase velocity of FIG. 13B can be obtained from the phase velocity $v(f)$. Comparison between the tomograms proves that the single lesion 3c includes both of a lesion shown in the tomogram of attenuation and a lesion show in the tomogram of phase

velocity.

[0070] Based on the two parameters, a complex propagation constant $\gamma(f) = \alpha(f) + j\beta(f)$ is determined where "j" represents an imaginary unit and $\beta(f) = \omega/v(f)$ and $\omega = 2\pi f$ are established. $\gamma(f)$ indicates that a propagation per unit length has an attenuation of $\alpha(f)$ and a phase rotation of $\beta(f)$.

[0071] According to a document (J. Biomechanics, vol. 28, No. 10, pp. 1145 to 1154, 1995), the complex propagation constant $\gamma(f)$ has the relationship of

$$\mu + j\omega\eta = -\rho\omega^2/\gamma^2(f)$$

between a shear (or shearing) elastic constant (a modulus of rigidity) μ , and a shear viscosity constant η . When a measured complex transfer constant $\gamma(f)$ is substituted into the right side of the formula and a real item and an imaginary item are arranged, the shear elastic constant μ and the shear viscosity constant η are expressed by the formulas below.

$$\mu = -\rho\omega^2(\alpha^2(f) - \beta^2(f))/\Delta$$

$$\eta = 2\rho\omega\alpha(f)\beta(f)/\Delta$$

Where,

$$\Delta = (\alpha^2(f) - \beta^2(f))^2 + (2\alpha(f)\cdot\beta(f))^2$$

is established. Thus, a shear elastic constant μ and a shear viscosity constant η are calculated for a small area between the point m and the point n on one ultrasonic beam (step S 16).

[0072] The above-described measurement is performed on each point of the lesion in and on the arterial wall on one ultrasonic beam (step S17). The point is set with the order of a waveform of a used ultrasonic wave, for example, at intervals of 375 microns. Further, an ultrasonic beam is scanned in real time along the axial direction of the blood vessel wall at intervals of 600 microns (FIG. 9). Thus, a tomogram with the shear elastic constant μ and the shear viscosity constant η is extracted in each local area of 375 microns \times 600 microns (step S18).

[0073] A tomogram of a shear elasticity modulus shown in FIG. 14A can be obtained from the shear elastic constant (i.e., shear elasticity modulus) μ . Moreover, a tomogram of a shear viscosity shown in FIG. 14B can be obtained from the shear viscosity constant (i.e., shear viscosity) η . The tomogram of the shear elasticity modulus shown in FIG. 14A corresponds to the tomogram of a phase velocity shown in FIG. 13B, and the tomogram of the shear viscosity shown in FIG. 14B corresponds to the tomogram of attenuation shown in FIG.

13A.

[0074] As with the processing of FIG. 3, regarding a representative lesion, the shear elastic constant μ and the shear viscosity constant η that are obtained on each point are compared with a pathologic chromatic figure and data of elasticity and viscosity of tissues such as lipid-rich, thrombus, elastic fiber, collagen fiber and calcification is registered in the data library 7A. At this point of time, as shown in FIG. 15, the tissues are mapped on a two-dimensional plane where the vertical axis represents a shear viscosity (Pa·s) and the horizontal axis represents a shear elasticity modulus (Pa), so that registration is performed. In this way, classification can be performed on the two-dimensional plane by using an elastic characteristic and a viscous characteristic, thereby increasing the accuracy of the data library 7A. For example, it is possible to identify a thrombus area, an elastic fiber, a collagen fiber, and a calcified area that are hard to identify only based on a shear viscosity. Further, it is possible to identify a lipid-rich area and a thrombus area that are hard to identify only based on a shear elasticity modulus.

[0075] Then, as with the processing of FIG. 4, on the tomogram of the shear elastic constant μ and shear viscosity constant η to be actually measured, a tissue characteristic is identified on each local area with reference to the data library 7A and electronic dyeing is performed. Thus, as shown in FIG. 16, tissues such as a lipid-rich area 3h, a thrombus area 3i, an elastic fiber 3j, a collagen fiber 3k, and a calcified area 3l can be clearly displayed on a screen by electronic dyeing.

[0076] Besides, as with the elasticity data of Embodiment 1, the kind of living tissue to be diagnosed may be identified only based on viscosity data acquired in the above-described manner.

Industrial Applicability

[0077] According to the present invention, in an ultrasonic diagnosis of a living tissue such as a lesion in a blood vessel, it is possible to readily identify the kind of living tissue such as a lipid rich area, a thrombus area, an elastic fiber, a collagen fiber, and a calcified area on an ultrasonic diagnostic image. Thus, a noninvasive diagnosis can be performed in a clinical diagnosis more properly and quickly as compared with the conventional art.

[0078] For example, the present invention makes it possible to predict the rupture of an atheroma (arteriosclerotic plaque) that is a main cause of an acute cardiovascular event such as unstable angina, acute myocardial infarction, and sudden death. Such a prediction is impossible in a noninvasive manner in the conventional art.

[0079] It is considered that a serious cardiovascular disease such as myocardial infarction and cerebral infarction is caused by the clogging of a thrombus in the lumen of a blood vessel, the thrombus being formed by

the rupture of an arteriosclerotic plaque (atheroma), which is formed on an arterial wall and is rich in lipid-rich. The present invention can evaluate the stability of an atherosclerotic lesion in a noninvasive manner.

[0080] Further, the present invention can evaluate the curative effect of a cholesterol lowering treatment.

Claims

1. A method for identifying a living tissue in an ultrasonic diagnosis, the method comprising:

measuring at least an elasticity of a living tissue to be diagnosed in each local small area by using ultrasound;
managing, in a data library, at least elasticity data for each kind of known living tissue, the elasticity data being composed of an elasticity modulus frequency histogram in each local small area for each kind of living tissue; and
identifying the kind of living tissue to be diagnosed, at least regarding the elasticity data serving as a measurement result, by using the elasticity data for each kind of known living tissue.

2. The method for identifying a living tissue in an ultrasonic diagnosis according to claim 1, further comprising:

exciting a vibration on a measured part of the living tissue to be diagnosed;
measuring a shear elasticity and a shear viscosity of the excited living tissue to be diagnosed in the measurement using ultrasound;
managing viscosity data for each kind of known living tissue in the management of the data library, the viscosity data being composed of a viscosity frequency histogram in each local small area for each kind of living tissue; and
identifying the kind of living tissue to be diagnosed, regarding the elasticity data and viscosity data serving as measurement results, by using the elasticity data and viscosity data for each kind of known living tissue in identification of the kind of living tissue to be diagnosed.

3. The method for identifying a living tissue in an ultrasonic diagnosis according to claim 2, wherein the vibration on the measured part of the living tissue to be diagnosed is excited by a turbulent flow component or a vortex component, the components being generated by a time change in a pulse of a pulsatile flow in a blood vessel.

4. The method for identifying a living tissue in an ultrasonic diagnosis according to claim 2, wherein the

vibration on the measured part of the living tissue to be diagnosed is excited by a vibration percutaneously applied to a part away from the measured part from an outside of a body.

5. The method for identifying a living tissue in an ultrasonic diagnosis according to claim 2, wherein in management of the data library, each kind of known living tissue is mapped on a two-dimensional plane having axes representing a shear elasticity modulus and a shear viscosity.

6. The method for identifying a living tissue in an ultrasonic diagnosis according to claim 1 or 2, wherein the living tissue to be diagnosed is a living tissue on a heart, a blood vessel, and so on.

7. The method for identifying a living tissue in an ultrasonic diagnosis according to claim 1 or 2, wherein the kind of known living tissue includes a lipid-rich area, a thrombus area, an elastic fiber, a collagen fiber, and a calcified fiber.

8. The method for identifying a living tissue in an ultrasonic diagnosis according to claim 1 or 2, wherein the local small area serving as a unit to measure an elasticity and/or a viscosity of the living tissue to be diagnosed is several tens to several hundreds square microns.

9. The method for identifying a living tissue in an ultrasonic diagnosis according to claim 1 or 2, wherein the kind of living tissue to be diagnosed is identified using the elasticity data and/or the viscosity data serving as measurement results, and the identification is performed by referring to the elasticity data and/or the viscosity data for each kind of known living tissue, the data being extracted from the data library, and determining the kind of known living tissue having a minimum distance.

10. The method for identifying a living tissue in an ultrasonic diagnosis according to claim 9, wherein the kind of known living tissue having a minimum distance from the elasticity data serving as a measurement result is determined by using Bayes decision method for dispersion and an average value of elasticity moduli determined from the histogram of the elasticity data on each kind of known living tissue.

11. The method for identifying a living tissue in an ultrasonic diagnosis according to claim 1 or 2, wherein an electronic chromatic figure is generated and displayed so as to identify in colors the kind of living tissue to be diagnosed, the kind of living tissue being identified for each local small area.

12. An ultrasonic diagnostic system, in which at least

an elasticity of a living tissue to be diagnosed is measured in each local small area by using ultrasound and a tomogram is displayed, the system comprising:

a data library for managing at least elasticity data for each kind of known living tissue, the elasticity data being composed of an elasticity modulus frequency histogram in each local small area for each kind of living tissue; and
a tissue identifying unit to identify the kind of living tissue to be diagnosed, regarding at least the elasticity data serving as a measurement result, by using the elasticity data for each kind of known living tissue.

- 13.** The ultrasonic diagnostic system according to claim 12, further comprising:

exciting means for exciting a vibration on a measured part of a living tissue to be diagnosed,

wherein the data library further includes viscosity data for each kind of known living tissue and manages the viscosity data for each kind of known living tissue, the viscosity data being composed of a viscosity frequency histogram in each local small area for each kind of living tissue, and

wherein the tissue identifying unit identifies the kind of living tissue to be diagnosed, regarding the elasticity data and viscosity data serving as measurement results of the excited living tissue to be diagnosed, by using the elasticity data and viscosity data for each kind of known living tissue.

- 14.** The ultrasonic diagnostic system according to claim 13, wherein each kind of known living tissue is mapped on a two-dimensional plane having axes representing a shear elasticity modulus and a shear viscosity.

- 15.** The ultrasonic diagnostic system according to claim 12 or 13, wherein the living tissue to be diagnosed is a living tissue on a heart, a blood vessel, and so on.

- 16.** The ultrasonic diagnostic system according to claim 12 or 13, wherein the kind of known living tissue includes a lipid-rich area, a thrombus area, an elastic fiber, a collagen fiber, and a calcified fiber.

- 17.** The ultrasonic diagnostic system according to claim 12 or 13, wherein the local small area serving as a unit to measure an elasticity of the living tissue to be diagnosed is several tens to several hundreds square microns.

- 18.** The ultrasonic diagnostic system according to claim 12 or 13, wherein the tissue identifying unit has identifying means which refers to the elasticity data for each kind of known living tissue, the data being extracted from the data library, and determines the kind of known living tissue having a minimum distance, for each elasticity data serving as a measurement result in each local small area.

- 19.** The ultrasonic diagnostic system according to claim 18, wherein the identifying means determines dispersion and an average value of elasticity moduli from the histogram of elasticity data of each kind of known living tissue, the data being extracted from the data library, and the identifying means performs identification using Bayes decision method.

- 20.** The ultrasonic diagnostic system according to claim 12 or 13, wherein the tissue identifying unit has electronic chromatic figure generating means for generating an electronic chromatic figure so as to identify in colors the kind of living tissue to be diagnosed, the kind of living tissue being identified for each local small area.

FIG. 1

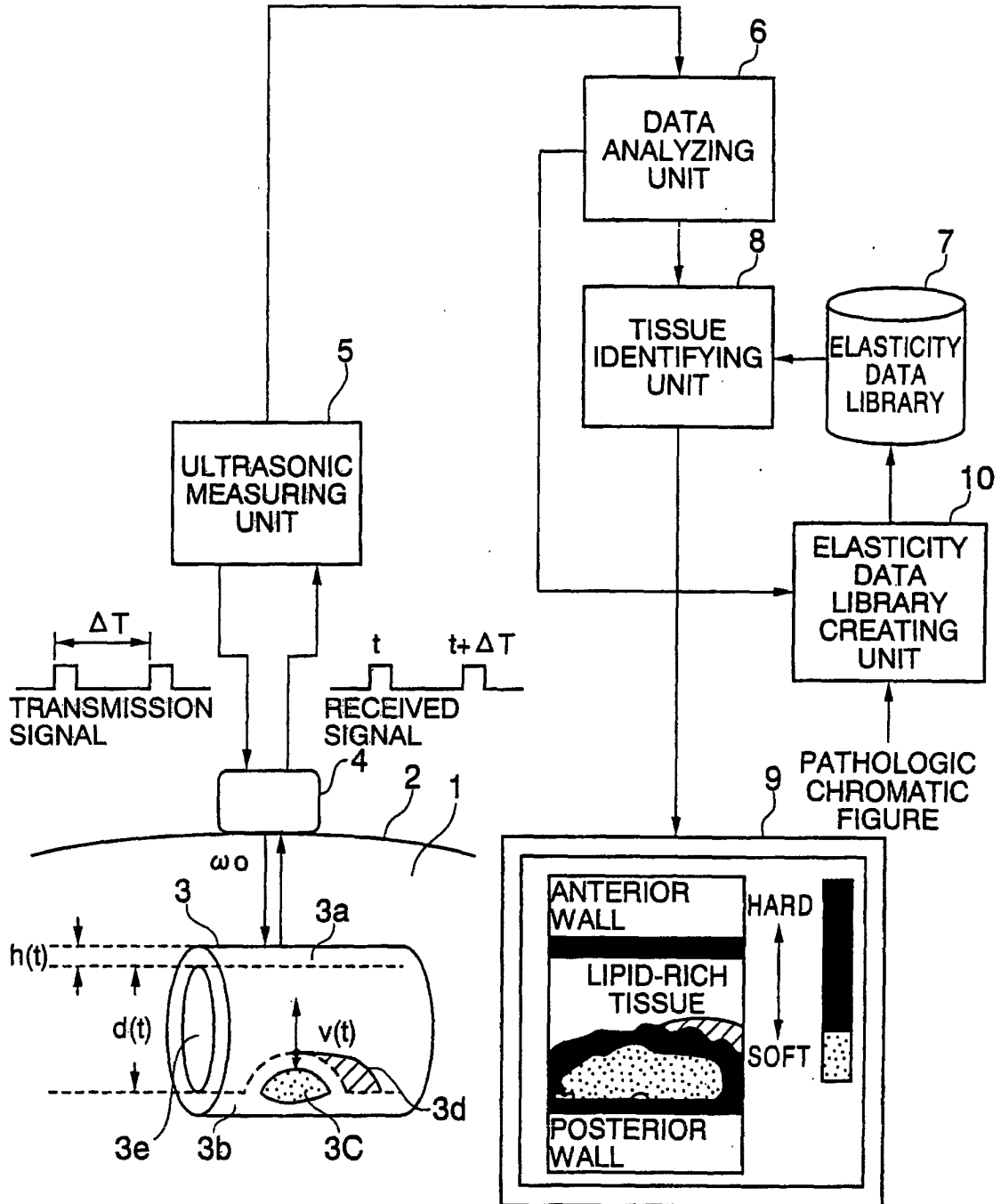

FIG. 2A

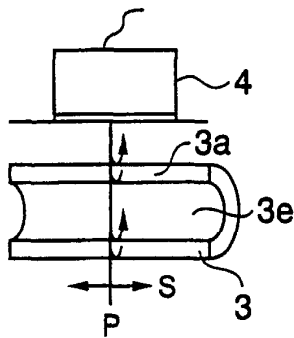

FIG. 2B

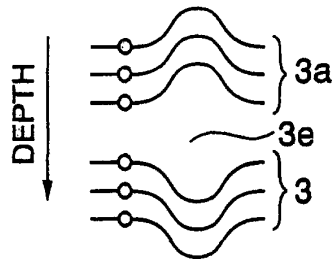

FIG. 2C

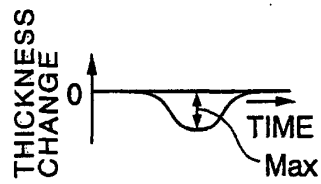

FIG. 2D

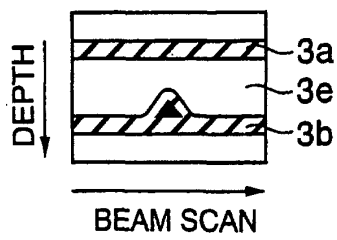

FIG. 2E

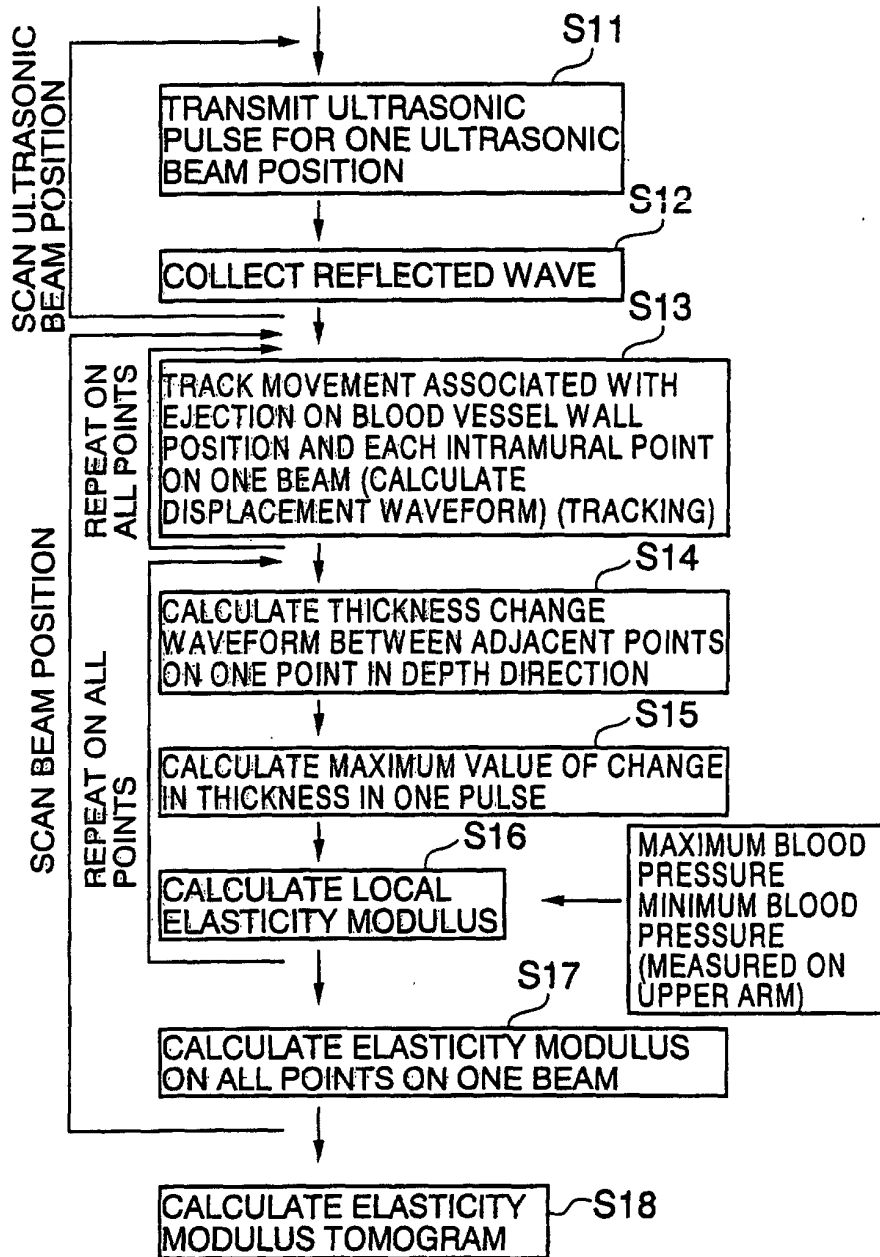

FIG. 3

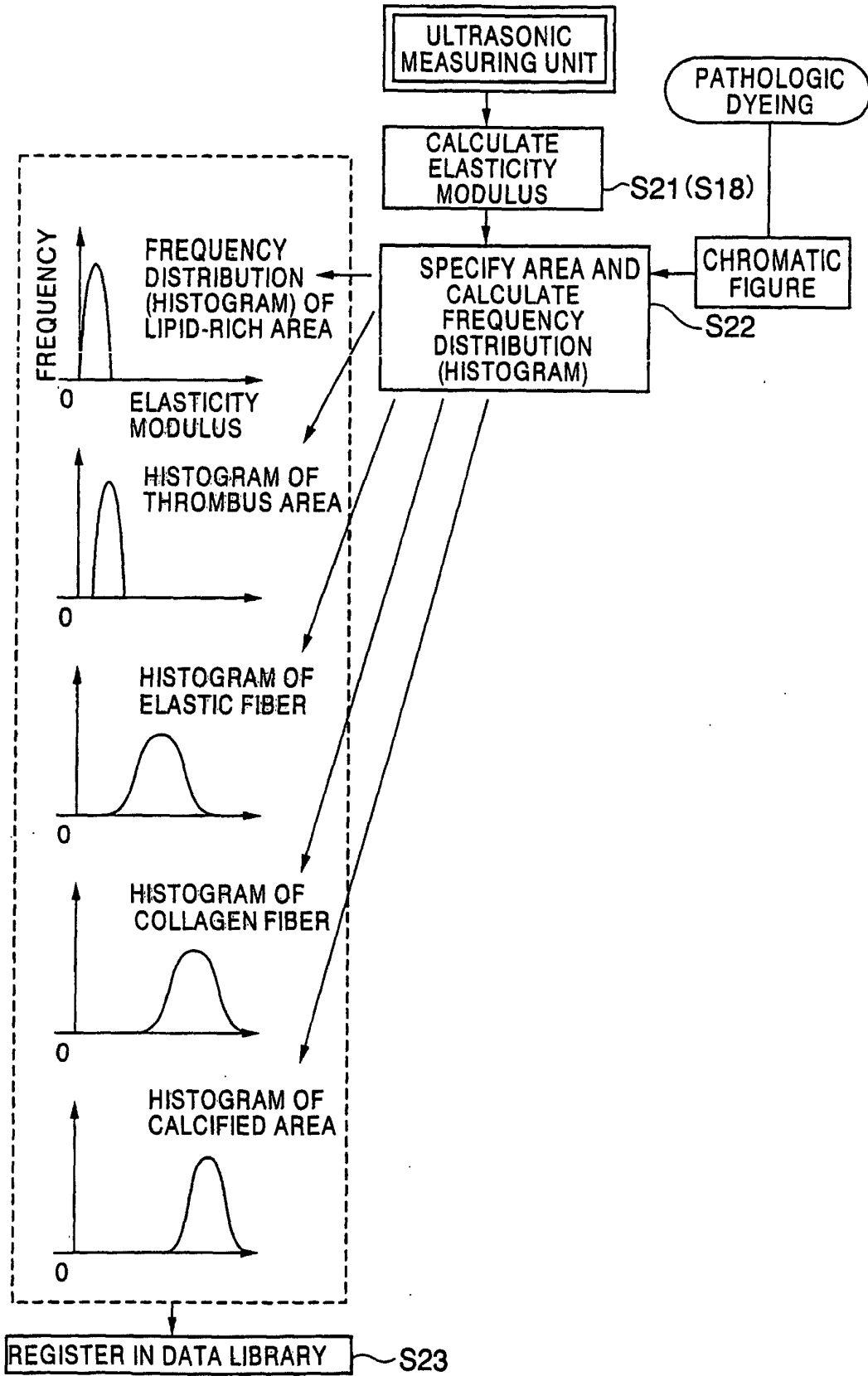

FIG. 4

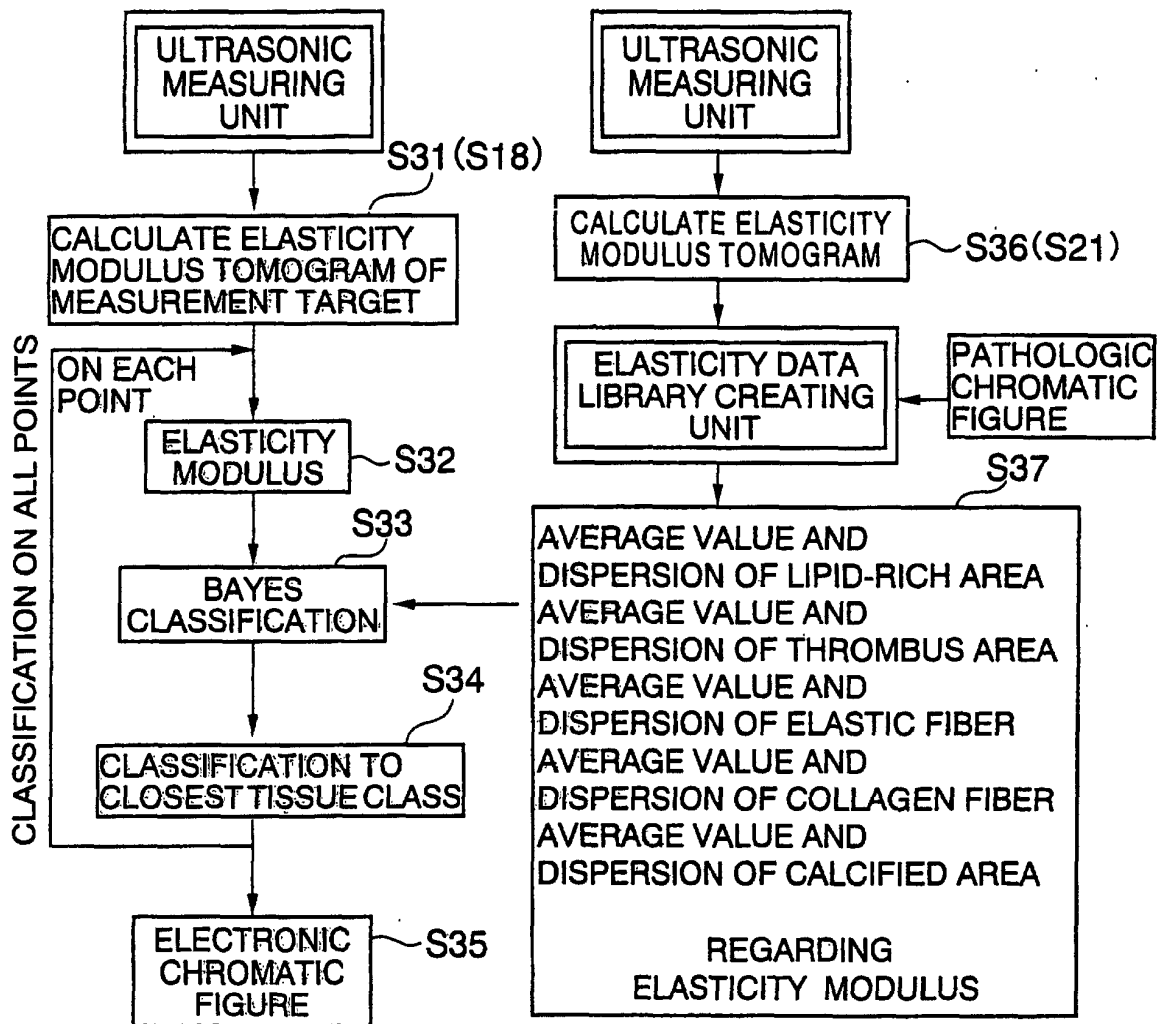

FIG. 5

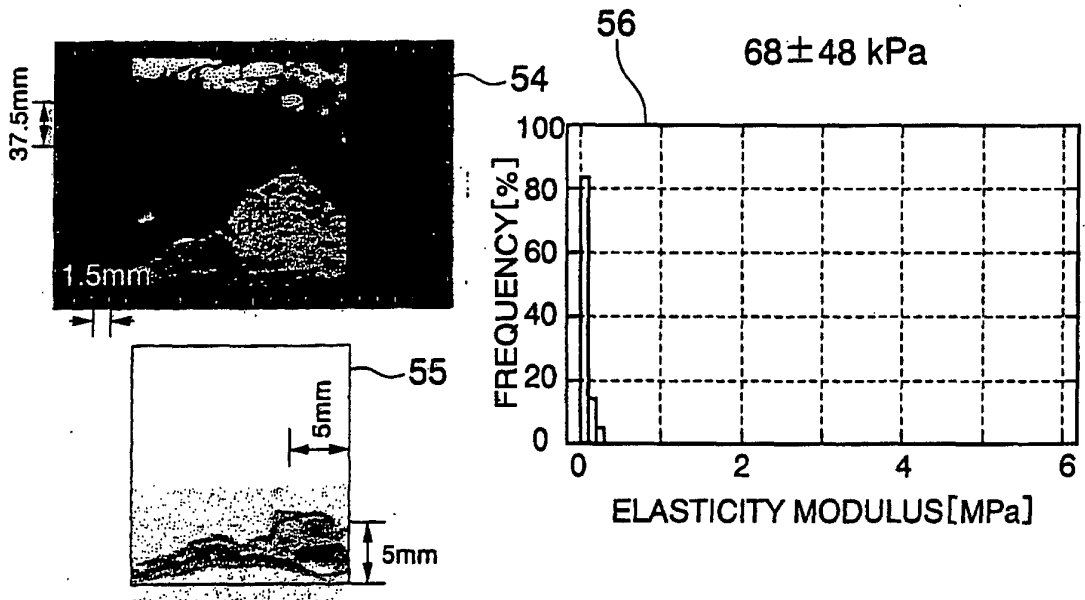
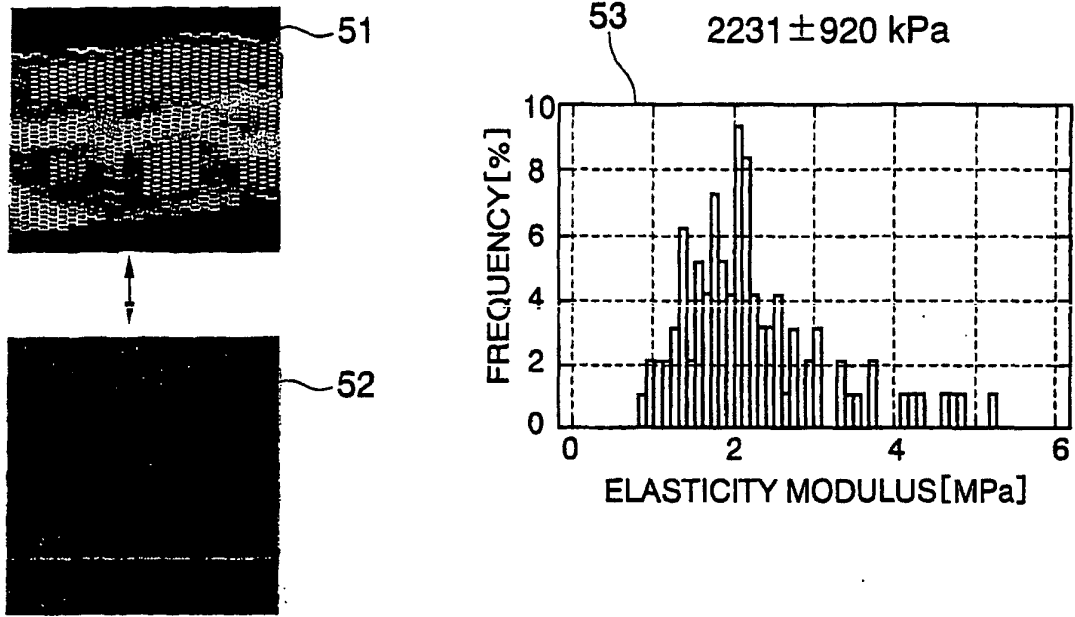

FIG. 6

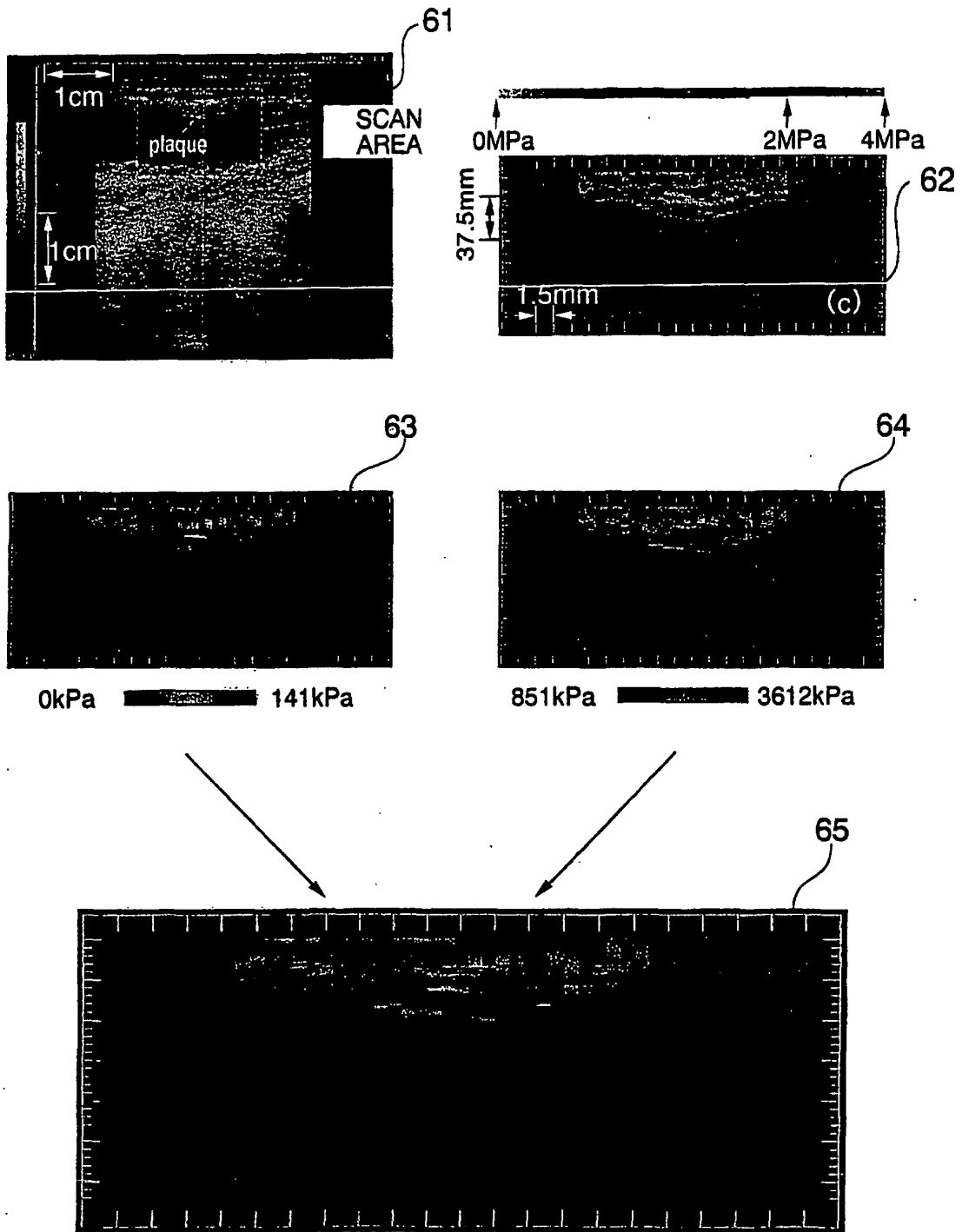

FIG. 7

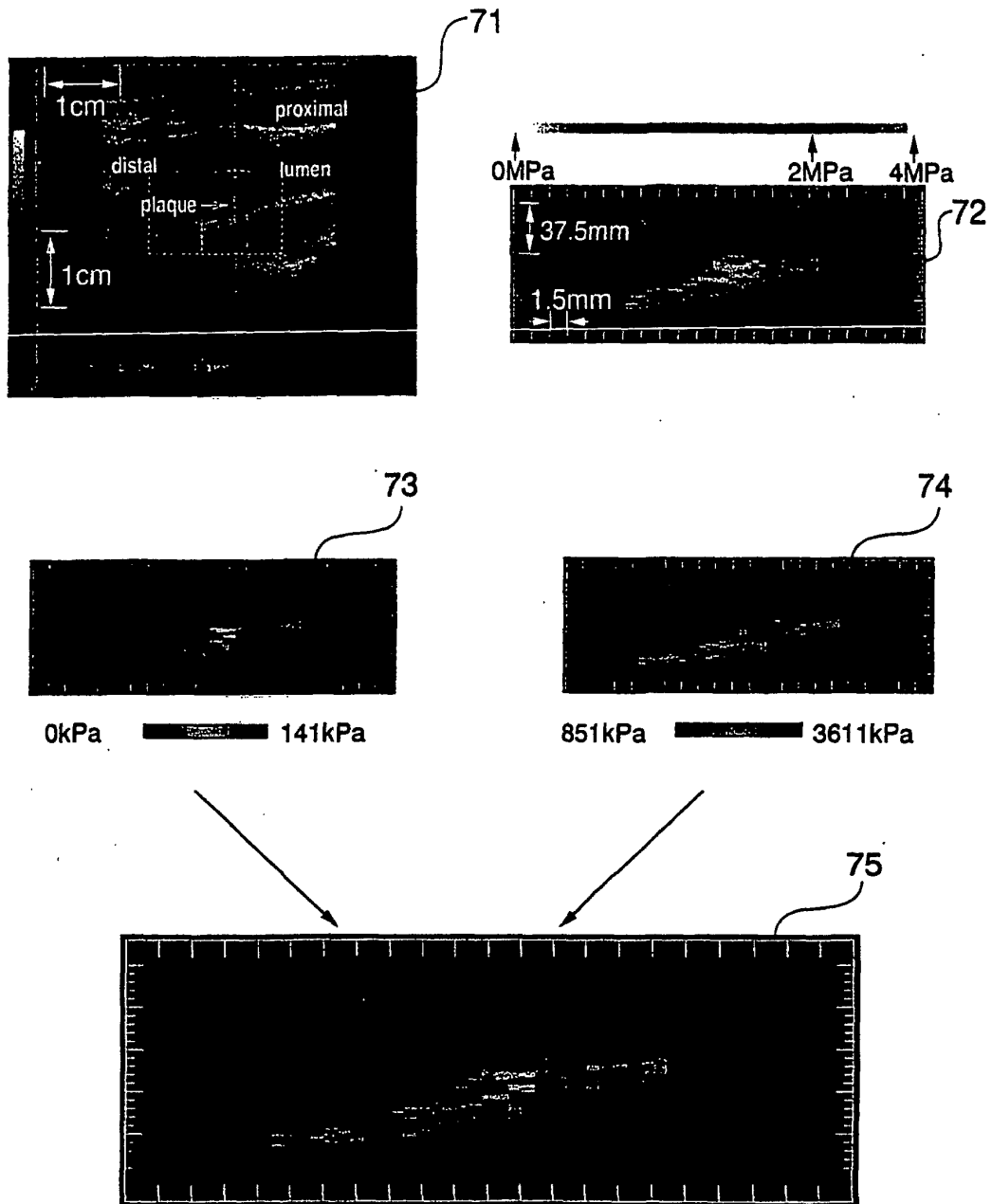

FIG. 9

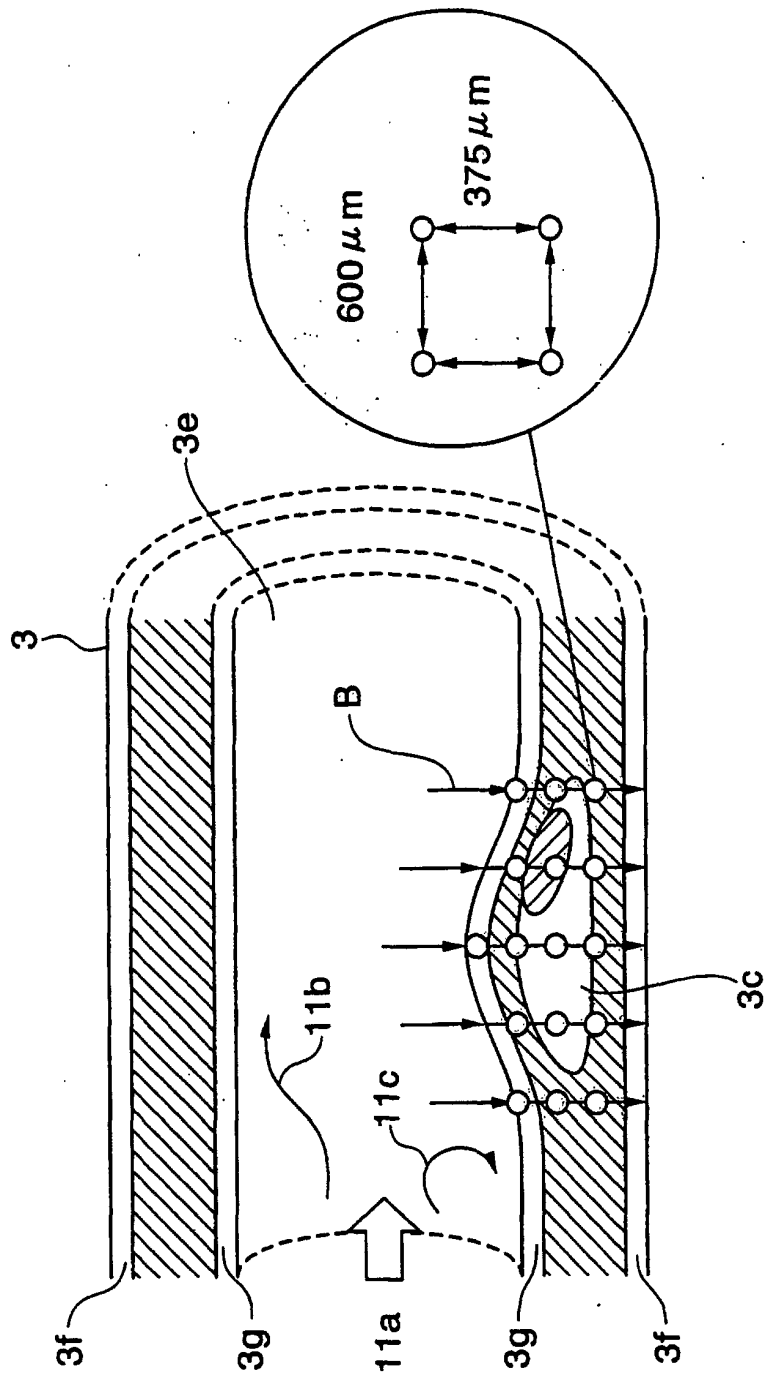

FIG. 10A

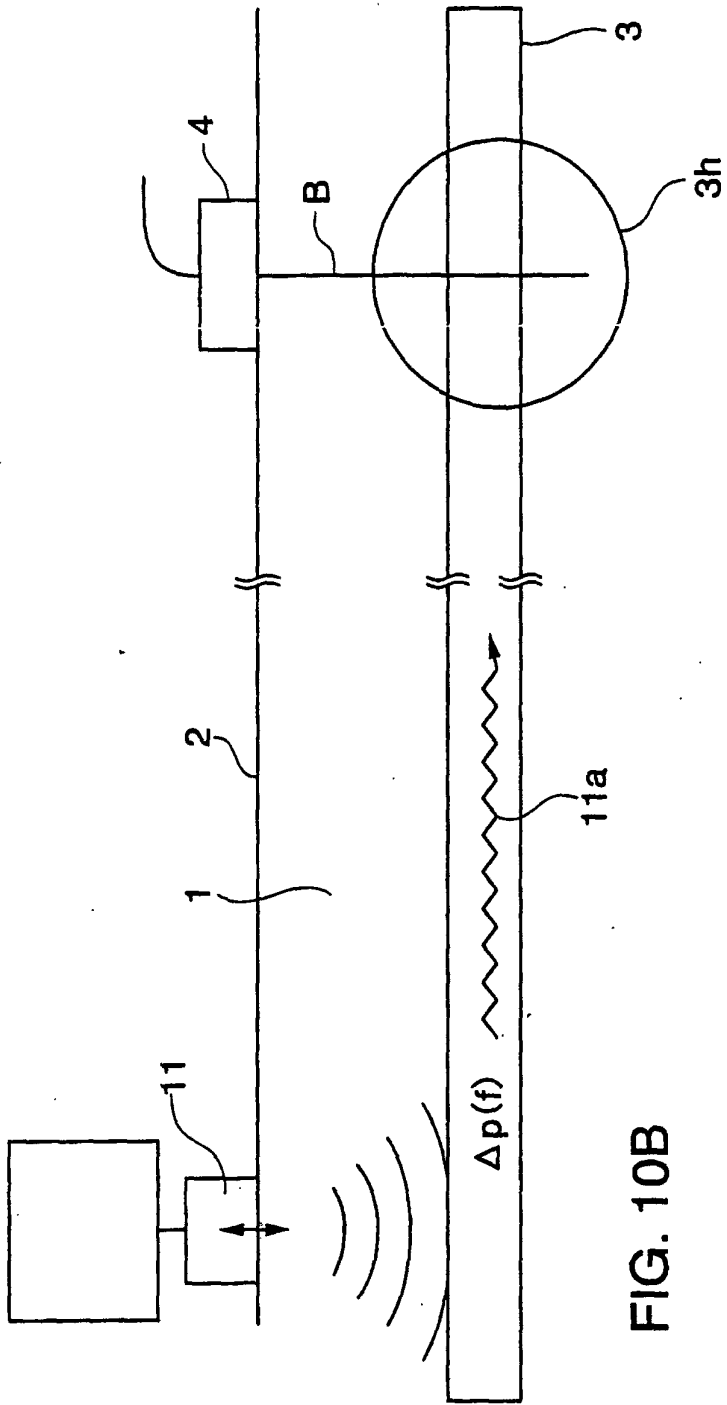

FIG. 10B

FIG. 11

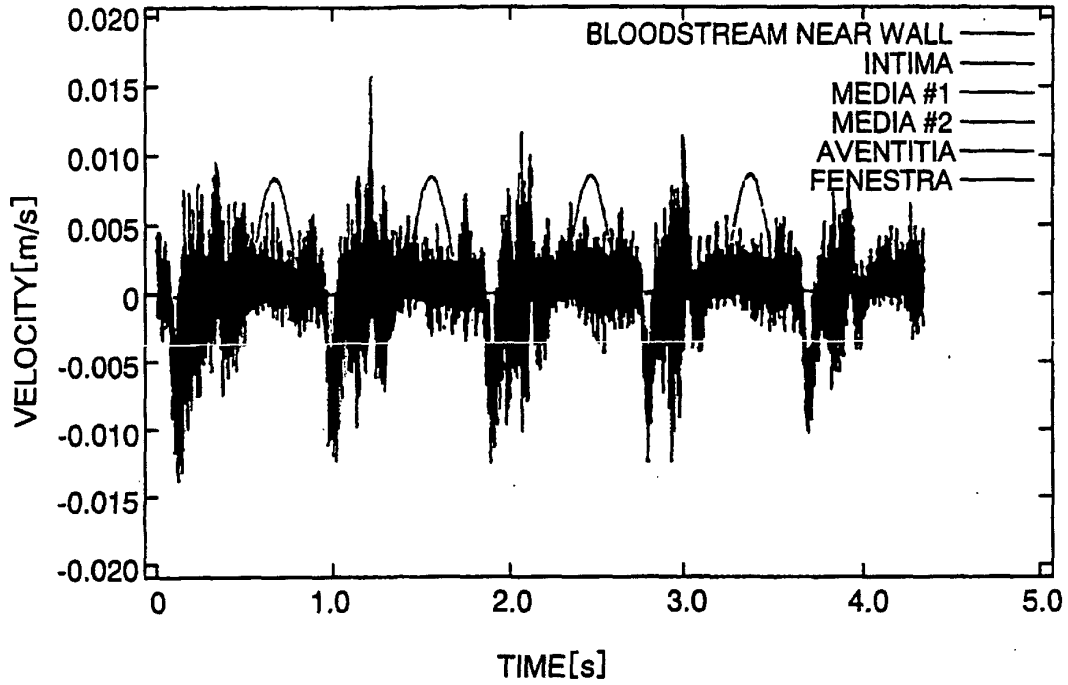

FIG. 12

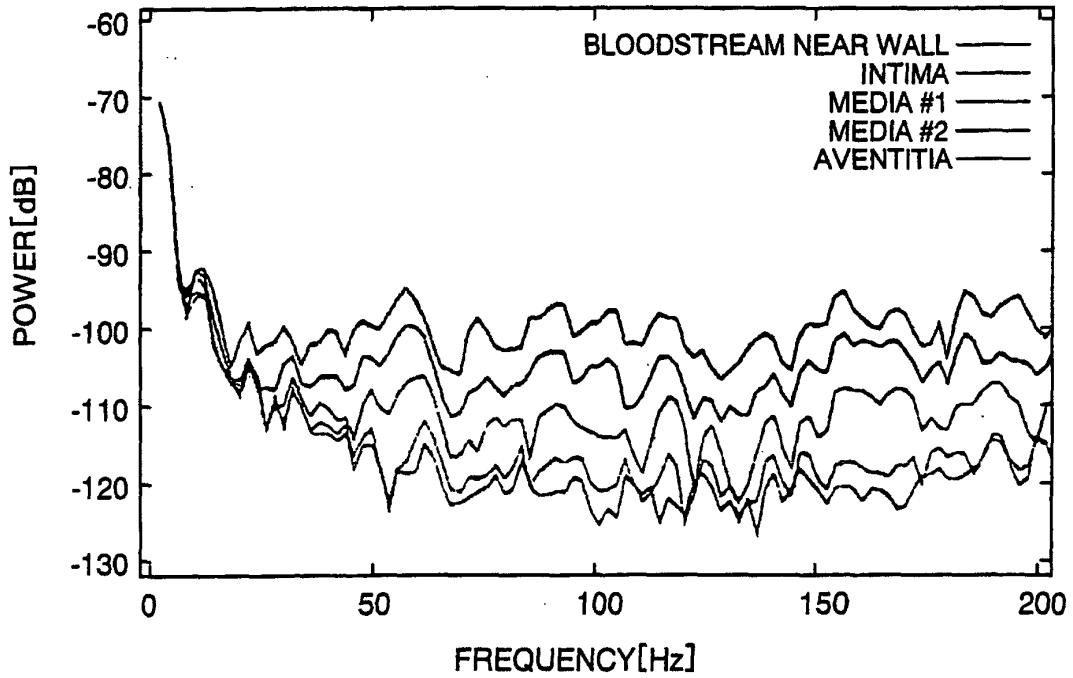

FIG. 13A

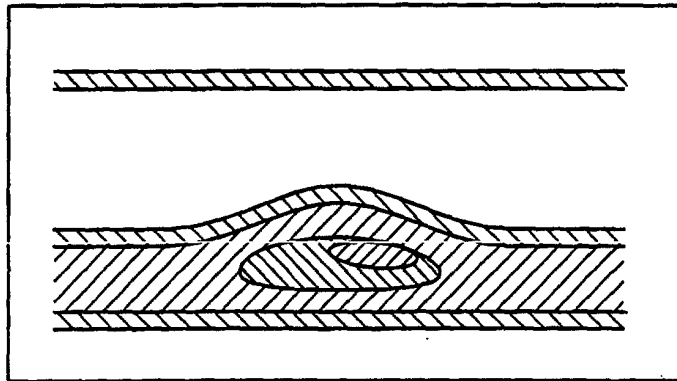

FIG. 13B

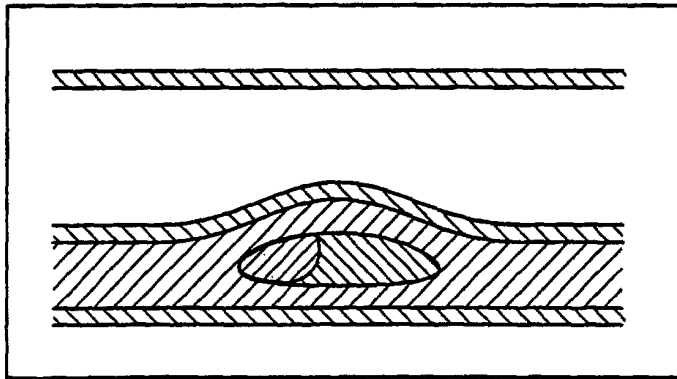

FIG. 14A

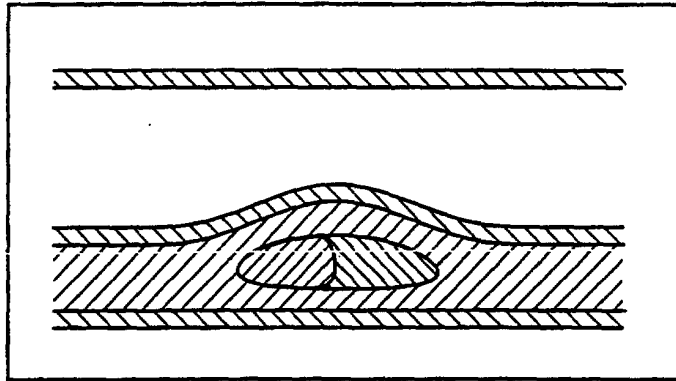

FIG. 14B

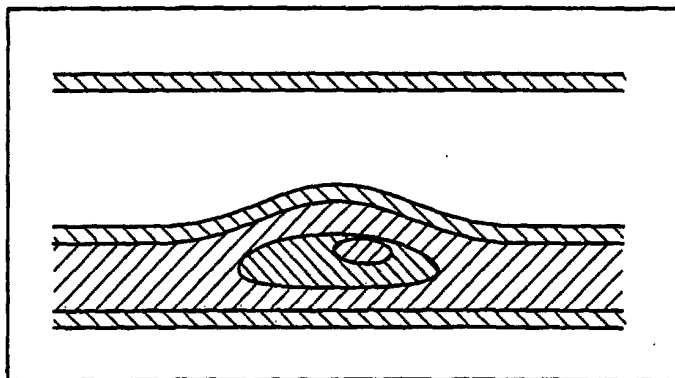

FIG. 15

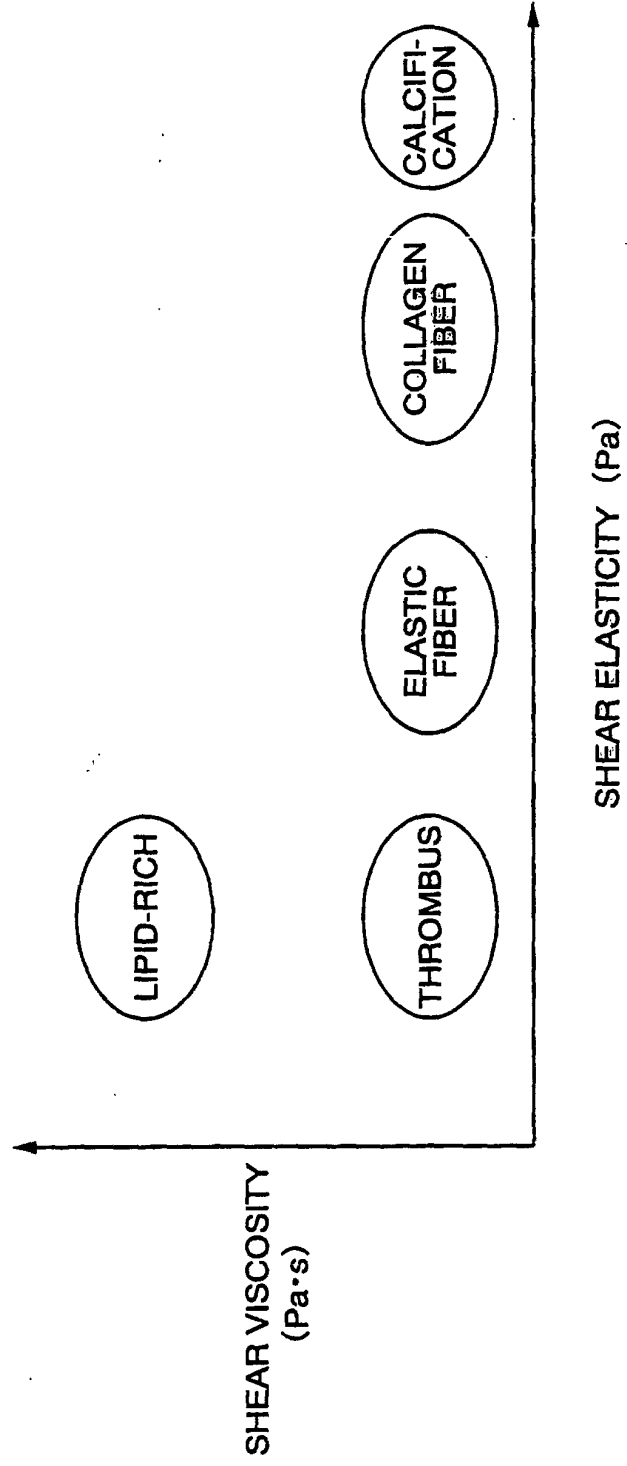

FIG. 16

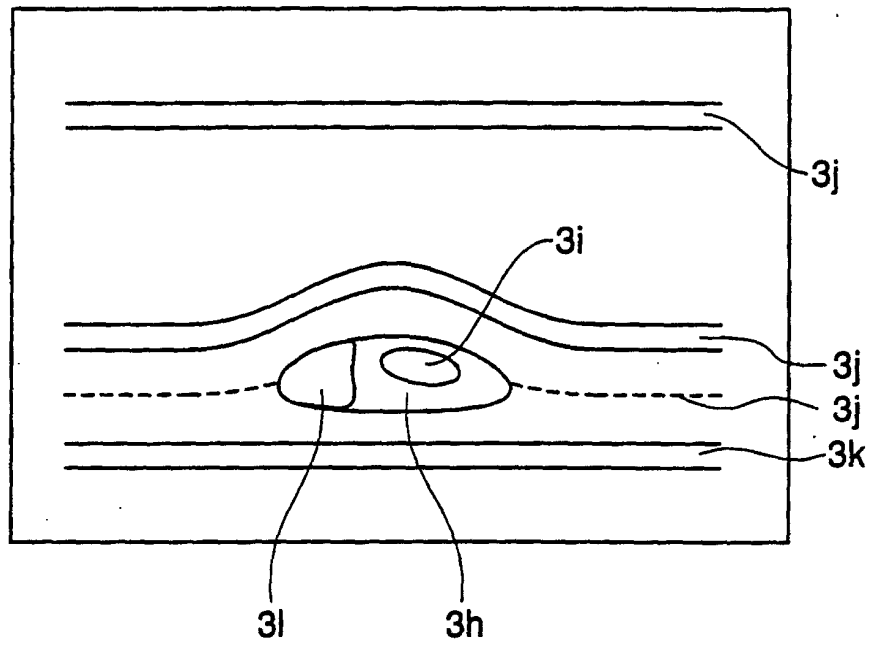
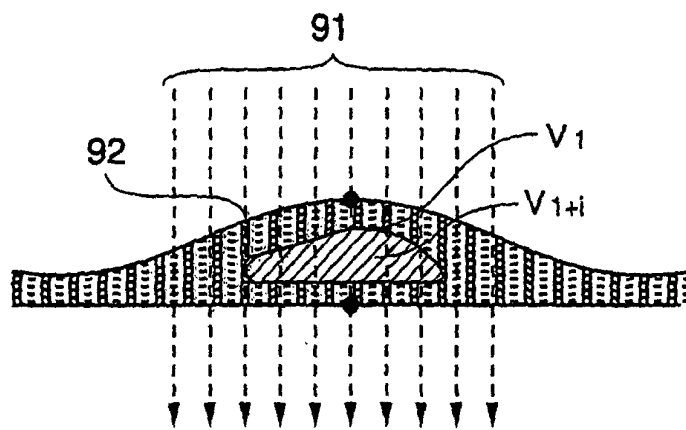

FIG. 17



INTERNATIONAL SEARCH REPORT

International application No.

PCT/JP02/08348

| A. CLASSIFICATION OF SUBJECT MATTER Int.Cl. ⁷ A61B8/08 | | |
|---|--|---|
| According to International Patent Classification (IPC) or to both national classification and IPC | | |
| B. FIELDS SEARCHED | | |
| Minimum documentation searched (classification system followed by classification symbols) Int.Cl. ⁷ A61B8/00 | | |
| Documentation searched other than minimum documentation to the extent that such documents are included in the fields searched Jitsuyo Shinan Koho 1922-1996 Toroku Jitsuyo Shinan Koho 1994-2002 Kokai Jitsuyo Shinan Koho 1971-2002 Jitsuyo Shinan Toroku Koho 1996-2002 | | |
| Electronic data base consulted during the international search (name of data base and, where practicable, search terms used) | | |
| C. DOCUMENTS CONSIDERED TO BE RELEVANT | | |
| Category* | Citation of document, with indication, where appropriate, of the relevant passages | Relevant to claim No. |
| Y | Hiroshi KANAI et al., "Kekkanheki Soshiki Seijo Shindan·Chiryō System", Journal of Medical Ultrasonics, 15 April, 2001 (15.04.01), Vol.28, No.3, p.J286 | 1, 6-12, 15-20 |
| A | Junko UMEZAWA et al., "Domyaku Heki no Nendansei Tokusei Hyōka o Mezashita Choonpa Keisoku ni yoru Domyaku Heki no Undo Sokudo Hakei karano Kyokusho Myakuha Denpan Sokudo no Sanshutsuho no Teian", The Institute of Electronics, Information and Communication Engineers Gijutsu Kenkyu Hokoku, 27 August, 1999 (27.08.99), Vol.99, No.260, pages 17 to 23 | 2-5, 13, 14 |
| A | S.F. Levinson et al., "SONOELASTIC DETERMINATION OF HUMAN SKELETAL MUSCLE ELASTICITY", Journal of Biomechanics, 1995.10, Vol.28, No.10, pages 1145 to 1154 | 2-5, 13, 14 |
| <input checked="" type="checkbox"/> Further documents are listed in the continuation of Box C. <input type="checkbox"/> See patent family annex. | | |
| * Special categories of cited documents: | | |
| "A" | document defining the general state of the art which is not considered to be of particular relevance | "T" |
| "E" | earlier document but published on or after the international filing date | "X" |
| "L" | document which may throw doubts on priority claim(s) or which is cited to establish the publication date of another citation or other special reason (as specified) | "Y" |
| "O" | document referring to an oral disclosure, use, exhibition or other means | "&" |
| "P" | document published prior to the international filing date but later than the priority date claimed | |
| Date of the actual completion of the international search 06 September, 2002 (06.09.02) | | Date of mailing of the international search report 01 October, 2002 (01.10.02) |
| Name and mailing address of the ISA/ Japanese Patent Office | | Authorized officer |
| Facsimile No. | | Telephone No. |

Form PCT/ISA/210 (second sheet) (July 1998)

INTERNATIONAL SEARCH REPORT

International application No.

PCT/JP02/08348

| C (Continuation). DOCUMENTS CONSIDERED TO BE RELEVANT | | |
|---|---|-----------------------|
| Category* | Citation of document, with indication, where appropriate, of the relevant passages | Relevant to claim No. |
| A | Yoshiki YAMAKOSHI "Zure Danseiha no Denpan Sokudo Suitei karano Soshiki Dansei no Keisoku to Eizoka", Journal of Medical Ultrasonics, 15 April, 2001 (15.04.01), Vol.28, No.3, p.J293 | 2-5, 13, 14 |
| Y | WO 99/47046 A1 (BARBARA ANN KARMANOS CANCER INSTITUTE), 23 September, 1999 (23.09.99), Page 2, lines 11 to 20; page 23, lines 9 to 15 & JP 2002-506666 A | 1, 6-12, 15-20 |
| Y | JP 2000-229078 A (Japan Science and Technology Corp.), 22 August, 2000 (22.08.00), Column 25, lines 43 to 46 (Family: none) | 20 |
| Y | WO 91/17517 A1 (GDP Technologies, Inc.), 14 November, 1991 (14.11.91), page 10, lines 10 to 25 & JP 5-501825 A | 20 |

Form PCT/ISA/210 (continuation of second sheet) (July 1998)

| | | | |
|----------------|---|---------|------------|
| 专利名称(译) | 超声和超声检查中的组织识别方法 | | |
| 公开(公告)号 | EP1421905A1 | 公开(公告)日 | 2004-05-26 |
| 申请号 | EP2002760659 | 申请日 | 2002-08-19 |
| [标]申请(专利权)人(译) | 独立行政法人科学技术振兴机构 | | |
| 申请(专利权)人(译) | 日本科学技术振兴机构 | | |
| 当前申请(专利权)人(译) | 日本科学技术振兴机构 | | |
| [标]发明人 | KANAI HIROSHI KOIWA YOSHIRO | | |
| 发明人 | KANAI, HIROSHI KOIWA, YOSHIRO | | |
| IPC分类号 | A61B5/103 A61B8/08 | | |
| CPC分类号 | A61B5/02007 A61B5/441 A61B5/7264 A61B8/0858 A61B8/485 | | |
| 优先权 | 2001249398 2001-08-20 JP | | |
| 其他公开文献 | EP1421905A4 EP1421905B1 | | |
| 外部链接 | Espacenet | | |

摘要(译)

在用于在超声诊断中识别活组织的方法中，通过使用超声测量每个局部小区域的待诊断的活组织的弹性。每种已知活组织的弹性数据由每种活组织的每个局部小区域中的弹性模量频率直方图组成，并在数据库中管理。关于用作测量结果的弹性数据，通过使用每种已知活组织的弹性数据来识别待诊断的活组织的种类。

