



(51) International Patent Classification:

A61B 5/04 (2006.01) A61B 8/08 (2006.01)
A61B 5/042 (2006.01) A61B 8/12 (2006.01)
A61B 8/00 (2006.01) A61B 19/00 (2006.01)

(21) International Application Number:

PCT/US2016/032017

(22) International Filing Date:

12 May 2016 (12.05.2016)

(25) Filing Language:

English

(26) Publication Language:

English

(30) Priority Data:

62/160,529 12 May 2015 (12.05.2015) US

(71) Applicant: ACUTUS MEDICAL, INC. [US/US]; 2210 Faraday Avenue, Suite 100, Carlsbad, California 92008 (US).

(72) Inventors: CHOU, Derrick R.; 17751 Ralphs Ranch Road, San Diego, California 92127 (US). BEATTY, Graydon E.; 9400 Old Cedar Ave., South #107, Bloomington, Minnesota 55435 (US). JULIAN, Marcus; 2455

Alta Vista Drive, Vista, California 92084 (US). CORVI, Timothy J.; 7922 Sitio Granado, Carlsbad, California 92009 (US). FLAHERTY, J. Christopher; 2122 Kirkland Lake Drive, Auburndale, Florida 33823 (US). FLAHERTY, R. Maxwell; 2122 Kirkland Lake Drive, Auburndale, Florida 33823 (US).

(74) Agents: MELLO, David M. et al.; Three Burlington Woods Drive, Suite 203, Burlington, Massachusetts 01803 (US).

(81) Designated States (unless otherwise indicated, for every kind of national protection available): AE, AG, AL, AM, AO, AT, AU, AZ, BA, BB, BG, BH, BN, BR, BW, BY, BZ, CA, CH, CL, CN, CO, CR, CU, CZ, DE, DK, DM, DO, DZ, EC, EE, EG, ES, FI, GB, GD, GE, GH, GM, GT, HN, HR, HU, ID, IL, IN, IR, IS, JP, KE, KG, KN, KP, KR, KZ, LA, LC, LK, LR, LS, LU, LY, MA, MD, ME, MG, MK, MN, MW, MX, MY, MZ, NA, NG, NI, NO, NZ, OM, PA, PE, PG, PH, PL, PT, QA, RO, RS, RU, RW, SA, SC, SD, SE, SG, SK, SL, SM, ST, SV, SY, TH, TJ, TM, TN, TR, TT, TZ, UA, UG, US, UZ, VC, VN, ZA, ZM, ZW.

[Continued on next page]

(54) Title: ULTRASOUND SEQUENCING SYSTEM AND METHOD

(57) Abstract: A system comprises a catheter configured for delivery to a body cavity defined by surrounding tissue; a plurality of ultrasound transducers coupled to a distal end of the catheter; and an electronics module configured to selectively turn on/off each ultrasound transducer according to a predetermined activation sequence and to process signals received from each ultrasound transducer to produce at least a 2D display of the surrounding tissue. A user can selectively calculate and display various aspects of cardiac activity. The user can display Dipole Density (DDM), Charge Density (CDM), or Voltage (V-V). The shape and location of the chamber (surface), and the potentials recorded at electrodes can be displayed. The system can also change back and forth between the different display modes, and with post processing tools, can change how various types of information is displayed. Methods are also provided.

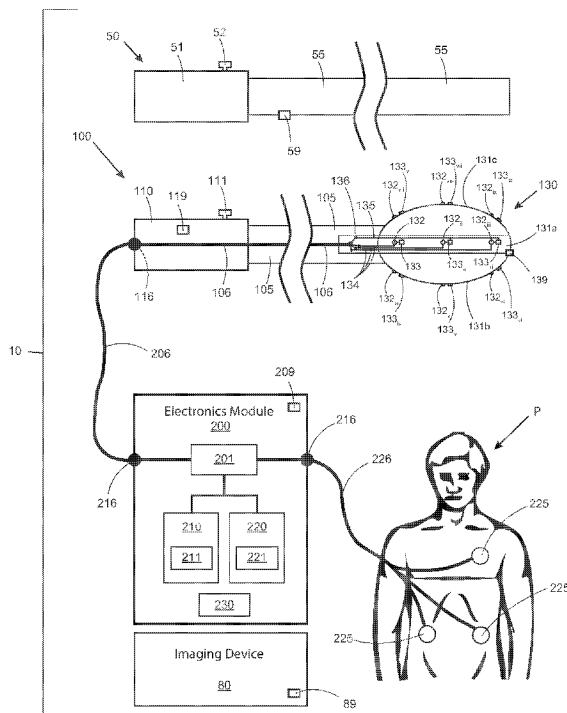

FIG 1

WO 2016/183285 A1



(84) Designated States (*unless otherwise indicated, for every kind of regional protection available*): ARIPO (BW, GH, GM, KE, LR, LS, MW, MZ, NA, RW, SD, SL, ST, SZ, TZ, UG, ZM, ZW), Eurasian (AM, AZ, BY, KG, KZ, RU, TJ, TM), European (AL, AT, BE, BG, CH, CY, CZ, DE, DK, EE, ES, FI, FR, GB, GR, HR, HU, IE, IS, IT, LT, LU, LV, MC, MK, MT, NL, NO, PL, PT, RO, RS, SE, SI, SK, SM, TR), OAPI (BF, BJ, CF, CG, CI, CM, GA, GN, GQ, GW, KM, ML, MR, NE, SN, TD, TG).

Declarations under Rule 4.17:

- *as to applicant's entitlement to apply for and be granted a patent (Rule 4.17(ii))*
- *as to the applicant's entitlement to claim the priority of the earlier application (Rule 4.17(iii))*
- *of inventorship (Rule 4.17(iv))*

Published:

- *with international search report (Art. 21(3))*

ULTRASOUND SEQUENCING SYSTEM AND METHOD

RELATED APPLICATIONS

[0001] The present application claims priority under 35 USC 119(e) to United States Provisional Patent Application Serial No. 62/160,529, entitled "Ultrasound Sequencing System and Method", filed May 12, 2015, which is incorporated herein by reference in its entirety.

[0002] The present application, while not claiming priority to, may be related to US Patent Application Serial No. 14/865,435, entitled "Method and Device for Determining and Presenting Surface Charge and Dipole Densities on Cardiac Walls", filed September 25, 2015, which is a continuation of US Patent No. 9,167,982 (hereinafter the '982 patent), entitled "Method and Device for Determining and Presenting Surface Charge and Dipole Densities on Cardiac Walls", issued October 27, 2015, which is a continuation of, which is a continuation of US Patent No. 8,918,158 (hereinafter the '158 patent), entitled "Method and Device for Determining and Presenting Surface Charge and Dipole Densities on Cardiac Walls", issued December 23, 2014, which is a continuation of US Patent No. 8,700,119 (hereinafter the '119 patent), entitled "Method and Device for Determining and Presenting Surface Charge and Dipole Densities on Cardiac Walls", issued April 15, 2014, which is a continuation of US Patent No. 8,417,313 (hereinafter the '313 patent), entitled "Method and Device for Determining and Presenting Surface Charge and Dipole Densities on Cardiac Walls", issued April 9, 2013, which was a 35 USC 371 national stage filing of Patent Cooperation Treaty Application No. CH2007/000380, entitled "Method and Device for Determining and Presenting Surface Charge and Dipole Densities on Cardiac Walls", filed August 3, 2007, published as WO2008/014629, which claimed priority to Swiss Patent Application No. 1251/06 filed August 3, 2006, each of which is hereby incorporated by reference.

[0003] The present application, while not claiming priority to, may be related to US Patent Application Serial No. 14/886,449, entitled "Device and Method for the Geometric Determination of Electrical Dipole Densities on the Cardiac Wall", filed October 19, 2015, which is a continuation of US Patent No. 9,192,318, entitled "Device and Method for the Geometric Determination of Electrical Dipole Densities on the Cardiac Wall", issued November 24, 2015, which is a continuation of US

Patent No. 8,512,255, entitled "Device and Method for the Geometric Determination of Electrical Dipole Densities on the Cardiac Wall", issued August 20, 2013, published as US2010/0298690 (hereinafter the '690 publication), which was a 35 USC 371 national stage application of Patent Cooperation Treaty Application No. PCT/IB09/00071 filed January 16, 2009, entitled "A Device and Method for the Geometric Determination of Electrical Dipole Densities on the Cardiac Wall", published as WO2009/090547, which claimed priority to Swiss Patent Application 00068/08 filed January 17, 2008, each of which is hereby incorporated by reference.

[0004] The present application, while not claiming priority to, may be related to US Patent Application Serial No. 14/003,671, entitled "Device and Method for the Geometric Determination of Electrical Dipole Densities on the Cardiac Wall", filed September 6, 2013, which is a 35 USC 371 national stage filing of Patent Cooperation Treaty Application No. PCT/US2012/028593, entitled "Device and Method for the Geometric Determination of Electrical Dipole Densities on the Cardiac Wall", published as WO2012/122517 (hereinafter the '517 publication), which claimed priority to US Patent Provisional Application Serial No. 61/451,357, each of which is hereby incorporated by reference.

[0005] The present application, while not claiming priority to, may be related to US Design Application Serial No. 29/475,273, entitled "Catheter System and Methods of Medical Uses of Same, Including Diagnostic and Treatment Uses for the Heart", filed December 2, 2013, which is a 35 USC 371 national stage filing of Patent Cooperation Treaty Application No. PCT/US2013/057579, entitled "Catheter System and Methods of Medical Uses of Same, Including Diagnostic and Treatment Uses for the Heart", filed August 30, 2013, which claims priority to US Patent Provisional Application Serial No. 61/695,535, entitled "System and Method for Diagnosing and Treating Heart Tissue", filed August 31, 2012, which is hereby incorporated by reference.

[0006] The present application, while not claiming priority to, may be related to US Patent Application Serial No. 14/762,944, entitled "Expandable Catheter Assembly with Flexible Printed Circuit Board (PCB) Electrical Pathways", filed July 23, 2015, which is a 35 USC 371 national stage filing of Patent Cooperation Treaty Application No. PCT/US2014/15261, entitled "Expandable Catheter Assembly with Flexible Printed Circuit Board (PCB) Electrical Pathways", filed February 7, 2014, published as WO2014/124231, which claims priority to US Patent Provisional

Application Serial No. 61/762,363, entitled "Expandable Catheter Assembly with Flexible Printed Circuit Board (PCB) Electrical Pathways", filed February 8, 2013, which is hereby incorporated by reference.

[0007] The present application, while not claiming priority to, may be related to Patent Cooperation Treaty Application No. PCT/US2015/11312, entitled "Gas-Elimination Patient Access Device", filed January 14, 2015, which claims priority to US Patent Provisional Application Serial No. 61/928,704, entitled "Gas-Elimination Patient Access Device", filed January 17, 2014, which is hereby incorporated by reference.

[0008] The present application, while not claiming priority to, may be related to Patent Cooperation Treaty Application No. PCT/US2015/22187, entitled "Cardiac Analysis User Interface System and Method", filed March 24, 2015, which claims priority to US Patent Provisional Application Serial No. 61/970,027, entitled "Cardiac Analysis User Interface System and Method", filed March 28, 2014, which is hereby incorporated by reference.

[0009] The present application, while not claiming priority to, may be related to US Application Serial No. 14/916,056, entitled "Devices and Methods for Determination of Electrical Dipole Densities on a Cardiac Surface", filed March 2, 2016, which is a 35 USC 371 national stage filing of Patent Cooperation Treaty Application No. PCT/US2014/54942, entitled "Devices and Methods for Determination of Electrical Dipole Densities on a Cardiac Surface", filed September 10, 2014, published as WO2015/038607, which claims priority to US Patent Provisional Application Serial No. 61/877,617, entitled "Devices and Methods for Determination of Electrical Dipole Densities on a Cardiac Surface", filed September 13, 2013, which is hereby incorporated by reference.

FIELD

[0010] The present invention is generally related to systems and methods that may be useful for the diagnosis and/or treatment of cardiac arrhythmias or other cardiac diseases or disorders, such as systems, devices, and methods that may be useful in mapping cardiac activity.

BACKGROUND

[0011] For localizing the origin(s) of cardiac arrhythmias it is common practice to measure the electric potentials located on the inner surface of the heart by electrophysiological means within the patient's heart. One method is to insert electrode catheters into the heart to record cardiac potentials during normal heart rhythm or cardiac arrhythmia. If the arrhythmia has a regular activation sequence, the timing of the electric activation measured in voltage at the site of the electrode can be accumulated when moving the electrode around during the arrhythmia, to create a three-dimensional map of the electric activation. By doing this, information on the location of the source of arrhythmia(s) and mechanisms, i.e., re-entrant circuits, can be diagnosed to initiate or guide treatment (radiofrequency ablation). The information can also be used to guide the treatment of cardiac resynchronization, in which implantable pacing electrodes are placed in specific locations within the heart wall or chambers to re-establish a normal level of coordinated activation of the heart.

[0012] A method using external sensors measures the electrical activity of the heart from the body surface using electrocardiographic techniques that include, for example, electrocardiograms (ECG) and vectorcardiography (VCG). These external sensor techniques can be limited in their ability to provide information and/or data on regional electrocardiac activity. These methods can also fail to localize bioelectric events in the heart.

[0013] A method using external sensors for the localization of cardiac arrhythmias utilizes body surface mapping. In this technique, multiple electrodes are attached to the entire surface of the thorax and the information of the cardiac electrograms (surface ECG) is measured in voltages that are accumulated into maps of cardiac activation. This measurement can be problematic because the electrical activity is time dependent and spatially distributed throughout the myocardium and also fails to localize bioelectric events in the heart. Complex mathematical methods are required to determine the electrical activation upon the outer surface of a heart model (i.e. epicardium), for instance, one obtained from CT or MRI imaging giving information on cardiac size and orientation within the thoracic cavity.

[0014] Alternatively, recordings of potentials at locations on the torso, for example, can provide body surface potential maps (BSPMs) over the torso surface.

Although the BSPMs can indicate regional cardiac electrical activity in a manner that can be different from conventional ECG techniques, these BSPM techniques generally provide a comparatively low resolution, smoothed projection of cardiac electrical activity that does not facilitate visual detection or identification of cardiac event locations (e.g., sites of initiation of cardiac arrhythmias) and details of regional activity (e.g., number and location of arrhythmogenic foci in the heart).

[0015] Since the localization of cardiac arrhythmias by the use of potentials is imprecise, the successful treatment of cardiac arrhythmias has been difficult and has demonstrated limited success and reliability. There is, therefore, a need for improved methods of localizing, diagnosing and treating cardiac arrhythmias.

SUMMARY

[0016] In accordance with one aspect of the inventive concept, provided is a body cavity imaging system, comprising: a catheter configured for delivery to a body cavity defined by surrounding tissue; a plurality of ultrasound transducers coupled to a distal end of the catheter; an electronics module configured to selectively turn on/off each ultrasound transducer according to a predetermined activation sequence and to process signals received from each ultrasound transducer to produce at least a 2D display of the surrounding tissue.

[0017] In various embodiments, the imaging system can be part of an electrophysiology system.

[0018] In various embodiments, the cavity can be a heart chamber and the surrounding tissue can be one or more walls of the heart chamber.

[0019] In various embodiments, the display can be a 3D display of the surrounding tissue.

[0020] In various embodiments, the 3D display of the surrounding tissue can be presented on a user interface system having a display screen and user control mechanism enabling graphical manipulation of the 3D display of the surrounding tissue.

[0021] In various embodiments, the graphical manipulation can include one or more of zoom in/out, rotate, select portions or subsections of the surrounding tissue.

[0022] In various embodiments, the plurality of ultrasound transducers can be coupled to a 3D array.

[0023] In various embodiments, the 3D array can be a basket array, spiral array, a balloon, radially deployable arms, and/or other expandable and compactible structures.

[0024] In various embodiments, the ultrasound transducers can be disposed on a plurality of splines of the 3D array.

[0025] In various embodiments, the 3D array can include at least three splines.

[0026] In various embodiments, at least two ultrasound transducers can be disposed on each spline.

[0027] In various embodiments, the system can further comprise a plurality of biopotential electrodes coupled to a distal end of the catheter.

[0028] In various embodiments, the biopotential electrodes can also be disposed on a plurality of splines of the 3D array.

[0029] In various embodiments, at least some of the biopotential electrodes and at least some of the ultrasound transducers can be disposed on the same splines.

[0030] In various embodiments, a biopotential electrode and an ultrasound transducer are disposed together to form an electrode/transducer pair, and the system includes a plurality of electrode/transducer pairs.

[0031] In various embodiments, one or more splines can comprise at least one electrode/transducer pair.

[0032] In various embodiments, one or more splines can comprise a plurality of electrode/transducer pairs.

[0033] In various embodiments, a plurality of splines can comprise at least one electrode/transducer pair.

[0034] In various embodiments, a plurality of splines can comprise a plurality of electrode/transducer pairs.

[0035] In various embodiments, a plurality of splines can comprise at least three electrode/transducer pairs.

[0036] In various embodiments, each spline can comprise a flexible PCB, and each electrode/transducer pair is electrically coupled to the flexible PCB.

[0037] In various embodiments, each electrode/transducer pair can share a common communication path on the flexible PCB.

[0038] In various embodiments, all electrode/transducer pairs on a spline can share a common communication path on the flexible PCB.

[0039] In various embodiments, the common communication path can be a common ground.

[0040] In various embodiments, the system can be further configured to correlate cardiac or other electrical activity to one or more images generated using imaging device.

[0041] In various embodiments, the imaging device can comprise an imaging device selected from the group consisting of: a fluoroscope; an MRI; a CT Scanner; an ultrasound imaging device; and combinations of two or more of these.

[0042] In various embodiments, the activation sequence can be a pattern of turning on/off the plurality of ultrasound transducers that avoids the sequential activation of two neighboring ultrasound transducers.

[0043] In various embodiments, the activation sequence can avoid the sequential activation of two transducers within two or three neighboring spaces of each other.

[0044] In various embodiments, the neighboring spaces can be considered spaces on a single spline; across splines, such as transducer 1 of spline 1 and transducer 1 of spline 2; and/or diagonally across splines, such as transducer 1 of spline 1 and transducer 2 of spline 2.

[0045] In various embodiments, the activation sequence pattern can be a pattern that avoids sequential activation of two transducers from a single spline.

[0046] In accordance with another aspect of the inventive concept, provided is a method of performing a diagnostic assessment, comprising: providing a cardiac diagnostic system, including a plurality of ultrasound transducers and a plurality of electrodes coupled to the end of a diagnostic catheter; inserting the diagnostic catheter into a heart chamber of a patient; placing the cardiac diagnostic system in a diagnostic mode; performing a biopotential measurement process; performing a localization process; performing an ultrasound measurement process; and interleaving a localization process and the ultrasound process.

[0047] In various embodiments, frequencies of the ultrasound transducers do not interfere with biopotential signals and biopotential signals do not interfere with localization signals.

[0048] In various embodiments, the biopotential measurement process can be performed continuously.

[0049] In various embodiments, the biopotential measurement process can be interleaved with the localization process and the ultrasound measurement process.

[0050] In various embodiments, the method can comprise performing the localization process longer than, or multiple times for, a single ultrasound measurement process.

[0051] In various embodiments, the method can comprise performing the ultrasound measurement process longer than, or multiple times for, a single localization process.

[0052] In various embodiments, the biopotential measurement process can include measuring and analyzing biopotentials from the electrodes.

[0053] In various embodiments, the biopotential measurement process can include determining dipole densities and/or surface charge densities from the biopotential data.

[0054] In accordance with another aspect of the inventive concepts, provided is a method of performing a localization process, comprising: providing a cardiac diagnostic system, including a plurality of biopotential electrodes and, optionally, a plurality of ultrasound transducers coupled to a distal end of a catheter; inserting the diagnostic catheter into a heart chamber of a patient; placing one or more pairs of surface electrodes on the patient and defining an individual axis for each pair of electrodes; generating one or more localization signals and transmitting same to the patient through the one or more pairs of surface electrodes; recording data collected from the one or more pairs of surface electrodes; filtering the recorded data to isolate signals correlating to the generated localization signals of each pair of surface electrodes; analyzing the filtered data to determine a location of each biopotential electrode in a coordinate system relative to the patient, the coordinate system defined by the one or more pairs of surface electrodes.

[0055] In various embodiments, there can be at least two pairs of electrodes, and one individual axis can be determined for each pair of surface electrodes.

[0056] In various embodiments, there can be at least three pairs of electrodes, and one individual axis is determined for each pair of surface electrodes.

[0057] In various embodiments, the three axes can define a three axis localization system.

[0058] In various embodiments, the coordinate system can be a 3D coordinate system.

[0059] In various embodiments, an origin of the coordinate system can be logically located within the heart of the patient.

[0060] In various embodiments, the method can comprise: placing surface electrodes from a first pair on the chest and back of the patient, defining a first axis; and/or placing surface electrodes from a second pair laterally on the sides of the patient, defining a second axis; and/or placing surface electrodes from a third pair on the neck or shoulder and thigh of the patient, defining a third axis.

[0061] In various embodiments, the method can comprise: placing surface electrodes from a first pair of electrodes laterally on the sides of the patient, defining a first axis; and/or placing surface electrodes from a second pair of electrodes on the upper chest and lower back of the patient, defining a second axis; and/or placing surface electrodes from a third pair of electrodes on the upper back and lower chest of the patient, defining a third axis.

[0062] In various embodiments, each pair of surface electrodes can be individually driven with a signal having a different frequency.

[0063] In various embodiments, localization signals can be generated at a frequency in a range of about 1-100kHz.

[0064] In various embodiments, the signals from each pair of surface electrodes can be individually recorded.

[0065] In various embodiments, the signals from each pair of surface electrodes can be individually filtered.

[0066] In various embodiments, the localization process can be interleaved with an ultrasound measurement process of the cardiac diagnostic system.

[0067] In various embodiments, the localization process can be interleaved with a biopotential measurement process of the cardiac diagnostic system.

[0068] In accordance with aspects of the inventive concept, provided is a method of performing an ultrasound measurement process, comprising: providing a cardiac diagnostic system, including a plurality of ultrasound transducers and, optionally, a plurality of biopotential electrodes coupled to a distal end of a catheter; inserting the diagnostic catheter into a heart chamber; activating (or ringing) an ultrasound transducer to generate an ultrasound transducer signal; ringing down the ultrasound transducer; sensing and recording a reflection of the ultrasound

transducer signal by a source; determining a distance from the transducer to the source based on the received reflection; repeating the above steps until all ultrasound transducers have been activated; and repeating the above steps for all ultrasound transducers until the ultrasound measurement process is complete or ended.

[0069] In various embodiments, the biopotential electrodes and ultrasound transducers can be paired to form electrode/ transducer pairs.

[0070] In various embodiments, the electrode/ transducer pairs can be disposed on a plurality of splines of a 3D array.

[0071] In various embodiments, activating an ultrasound transducer can include closing one or more switches, thereby electrically connecting the transducer to a signal generator.

[0072] In various embodiments, the one or more switches can comprise an opto-coupler.

[0073] In various embodiments, the opto-coupler can have an activation time in a range of about 0.01 μ s, or 500 μ s.

[0074] In various embodiments, activating the transducer can include generating a pulsed drive signal configured to ring, vibrate, and/or otherwise cause the transducer to generate an ultrasonic pulse.

[0075] In various embodiments, the drive signal can comprise a signal with a frequency in a range of about 1 MHz and 25 MHz, such as 10 MHz.

[0076] In various embodiments, the drive signal frequency can be about 10 MHz.

[0077] In various embodiments, the drive signal can further comprise a signal with a pulse width in a range of about 0.1 μ s and 10 μ s.

[0078] In various embodiments, the drive signal pulse width can be about 2.0 μ s.

[0079] In various embodiments, the ring down can have a duration of between about 0.05 μ s and 1 μ s for dissipation of vibration of the ultrasound transducer.

[0080] In various embodiments, the ring down can have a duration of about 0.1 μ s.

[0081] In various embodiments, sensing the reflection can be performed for a duration in a range of about 1 μ s and 200 μ s.

[0082] In various embodiments, the sensing duration can be about 100 μ s.

[0083] In various embodiments, the source can be an inner wall of a cardiac chamber.

[0084] In various embodiments, the activation of the transducer can cause deactivation of a paired biopotential electrode.

[0085] In various embodiments, the method can further comprise non-sequentially activating electrode/ transducer pairs, thereby not broadening a temporary "blind spot" of a neighboring biopotential electrode caused by the activation of the ultrasound transducer.

[0086] In various embodiments, the patient can be a living being.

[0087] In various embodiments, the patient can be a simulated being or heart.

[0088] In accordance with aspects of the inventive concept, provided is a body cavity imaging system as shown and/or described.

[0089] In accordance with aspects of the inventive concept, provided is a cardiac diagnostic system as shown and/or described.

[0090] In accordance with aspects of the inventive concept, provided is a cardiac diagnostic process as shown and/or described.

[0091] In accordance with aspects of the inventive concept, provided is a localization process as shown and/or described.

[0092] In accordance with aspects of the inventive concept, provided is a biopotential measurement process as shown and/or described.

[0093] In accordance with aspects of the inventive concept, provided is an ultrasound imaging method as shown and/or described.

BRIEF DESCRIPTION OF THE DRAWINGS

[0094] FIG. 1 illustrates a schematic view of an exemplary embodiment of a cardiac analysis system comprising a catheter with an assembly including multiple electrical components that can be deployed within a body, in accordance with aspects of the present inventive concepts.

[0095] FIG. 2 provides a flowchart of an embodiment of a method of performing a diagnostic assessment, in accordance with aspects of the present inventive concepts.

[0096] FIG. 3 provides a flowchart of an embodiment of a method of performing a localization process, in accordance with aspects of the present inventive concepts.

[0097] FIG. 4 provides a flowchart of an embodiment of a method of performing an ultrasound measurement process, in accordance with aspects of the present inventive concepts.

[0098] FIG. 5 provides a perspective view of an embodiment of a diagnostic catheter, in accordance with aspects of the present inventive concepts.

[0099] FIG. 5A is a perspective view of the catheter of FIG. 5 in an altered shape, in accordance with aspects of the present inventive concepts.

[0100] FIG. 6 provides a representation of an embodiment of an activation sequence of an array of ultrasound transducers disposed on six splines, in accordance with aspects of the present inventive concepts.

[0101] FIG. 7 provides an embodiment of a block diagram of a user interface system that can be used with a diagnostic catheter as described herein, for example, in accordance with the present inventive concepts.

[0102] FIGS. 8A – 8C provide different views relating to the output of the user interface system, in accordance with aspects of the present inventive concepts.

[0103] FIG. 9 provides a functional block diagram of an embodiment of a cardiac information processing system, in accordance with the present inventive concepts.

DETAILED DESCRIPTION

[0104] Various exemplary embodiments will be described more fully hereinafter with reference to the accompanying drawings, in which some exemplary embodiments are shown. The present inventive concepts can, however, be embodied in many different forms and should not be construed as limited to the exemplary embodiments set forth herein.

[0105] It will be understood that, although the terms first, second, etc. are used herein to describe various elements, these elements should not be limited by these terms. These terms are used to distinguish one element from another, but not to imply a required sequence of elements. For example, a first element can be

termed a second element, and, similarly, a second element can be termed a first element, without departing from the scope of the present invention. As used herein, the term "and/or" includes any and all combinations of one or more of the associated listed items. And a "combination" of associated listed items need not include all of the items listed, but can include all of the items listed.

[0106] It will be understood that when an element is referred to as being "on" or "attached", "connected" or "coupled" to another element, it can be directly on or connected or coupled to the other element or intervening elements can be present. In contrast, when an element is referred to as being "directly on" or "directly connected" or "directly coupled" to another element, there are no intervening elements present. Other words used to describe the relationship between elements should be interpreted in a like fashion (e.g., "between" versus "directly between," "adjacent" versus "directly adjacent," etc.).

[0107] The terminology used herein is for the purpose of describing particular embodiments only and is not intended to be limiting of the invention. As used herein, the singular forms "a," "an" and "the" are intended to include the plural forms as well, unless the context clearly indicates otherwise. It will be further understood that the terms "comprises," "comprising," "includes" and/or "including," when used herein, specify the presence of stated features, steps, operations, elements, and/or components, but do not preclude the presence or addition of one or more other features, steps, operations, elements, components, and/or groups thereof.

[0108] Spatially relative terms, such as "beneath," "below," "lower," "above," "upper" and the like can be used to describe an element and/or feature's relationship to another element(s) and/or feature(s) as, for example, illustrated in the figures. It will be understood that the spatially relative terms are intended to encompass different orientations of the device in use and/or operation in addition to the orientation depicted in the figures. For example, if the device in the figures is turned over, elements described as "below" and/or "beneath" other elements or features would then be oriented "above" the other elements or features. The device can be otherwise oriented (e.g., rotated 90 degrees or at other orientations) and the spatially relative descriptors used herein interpreted accordingly.

[0109] Various exemplary embodiments are described herein with reference illustrations of idealized or representative structures and intermediate structures. As such, variations from the shapes of the illustrations as a result, for example, of

manufacturing techniques and/or tolerances, are to be expected. Thus, exemplary embodiments should not be construed as limited to the particular shapes of regions illustrated herein but are to include deviations in shapes that result, for example, from manufacturing.

[0110] To the extent that functional features, operations, and/or steps are described herein, or otherwise understood to be included within various embodiments of the present inventive concepts, such functional features, operations, and/or steps can be embodied in functional blocks, units, modules, operations and/or methods. And to the extent that such functional blocks, units, modules, operations and/or methods include computer program code, such computer program code can be stored in a computer readable medium, e.g., such as non-transitory memory and media, that is executable by at least one computer processor.

[0111] Referring now to FIG. 1, a schematic view of an embodiment of a cardiac analysis system comprising a catheter with an assembly including multiple electrical components that can be deployed within a body is illustrated, consistent with the present inventive concepts. System 10 includes diagnostic catheter 100 and electronics module 200. In some embodiments, system 10 can further include an introducer 50 and/or imaging device 80. Introducer 50 comprises handle 51 and elongate shaft 55. Shaft 55 comprises at least one lumen, such as a lumen configured to slidably receive diagnostic catheter 100 within shaft 55. In some embodiments introducer 50 comprises a transeptal access sheath or other device configured to provide access to a body space or cavity, such as a heart chamber, for example. Handle 51 can include a knob, lever, switch or other control, generally referred to herein as control 52. Control 52 can be configured to steer or otherwise deflect the distal end of introducer 50. Imaging device 80 can comprise an imaging device selected from the group consisting of: a fluoroscope; an MRI; a CT Scanner; an ultrasound imaging device; and combinations of two or more of these. However, other imaging devices could be used in various embodiments.

[0112] Diagnostic catheter 100 includes handle 110, and an elongate flexible shaft, shaft 105, extending from handle 110. Attached to the distal end of shaft 105 is a radially expandable and/or compactable assembly, expandable assembly 130. In an alternative embodiment, expandable assembly 130 is mounted to (e.g. surrounding) a distal portion of shaft 105, at a location proximal to the distal end of shaft 105. In some embodiments, expandable assembly 130 is constructed and

arranged as described in reference to applicant's co-pending United States Patent Application Serial Number 14/422,941, titled "System and Method for Diagnosing and Treating Heart Tissue", filed February 5, 2015, the content of which is incorporated herein by reference in its entirety. Shaft 105 and expandable assembly 130 are constructed and arranged to be inserted into a body (e.g. an animal body or a human body, such as the body of Patient P), and advanced through a body vessel, such as a femoral vein, jugular vein, or other blood vessel. Shaft 105 and expandable assembly 130 can be constructed and arranged to be inserted through introducer 50, such as when expandable assembly 130 is in a compacted state, and slidingly advanced through a lumen of shaft 55 into a body space, such as a chamber of the heart, such as the right atrium or the left atrium, as examples.

[0113] Handle 110 can include one or more controls, such as control 111. Control 111 can comprise a knob, switch, lever, button, slide, or other control configured to perform a function selected from the group consisting of: steer the distal portion of shaft 105; control the expansion and/or contraction of expandable assembly 130 such as by advancing and/or retracting a control rod, not shown but such as is described herebelow in reference to FIG. 5; control the shape of expandable assembly 130, such as by advancing or retracting a control rod operably attached to expandable assembly 130; close and/or open an electrical connection, such as to provide power to one or more components of expandable assembly 130; initiate a process or otherwise send a command or other user activated signal to electronics module 200; and combinations of these.

[0114] Expandable assembly 130 can comprise a structure including multiple flexible arms or splines, splines 131a-c (singly or collectively splines 131), as shown. In some embodiments, expandable assembly 130 can comprise between two and ten splines 131, such as six splines 131. In the embodiment of FIG. 1, three splines 131a-c are equally spaced about a central axis of catheter 100 (i.e., a spacing of 120° between each spline when expandable assembly 130 is deployed in its expanded state). In other embodiments, splines 131 can be equally or unequally spaced, such as two, four, eight or twelve splines 131 with an equal spacing of 180°, 90°, 60°, 45°, and/or 30°, respectively. In some embodiments, expandable assembly 130 can comprise a balloon, radially deployable arms, and/or other expandable and compactible structure.

[0115] Expandable assembly 130 can further comprise multiple “pairs” of electrical components, for example, at least one pair comprising an electrode 132 and an ultrasound element, transducer 133. Each electrode 132 can be configured to record a voltage, such as the voltage present on a surface of the heart or at a location within a heart chamber. Each ultrasound transducer 133 can be configured to send and/or receive ultrasound signals, such as to produce an anatomical image of the tissue of at least a portion of the heart or other patient anatomical location. Electrodes 132 and ultrasound transducers 133 can comprise different shapes, such as a shape selected from the group consisting of: round; triangular; rectangular; hexagonal; trapezoidal; and combinations of two or more of these. In some embodiments, a first electrode 132 has a different shape than a second electrode 132. In some embodiments, a first ultrasound transducer 133 has a different shape than a second ultrasound transducer 133. In some embodiments, one or more ultrasound transducers 133 each comprise a single element or an array of elements (e.g. a microarray of ultrasound elements), for example an array of ultrasound elements configured as a phased array (e.g. to allow steering and/or focusing of ultrasound energy). In some embodiments, one or more ultrasound transducers 133 comprise an element selected from the group consisting of: bulk ceramic (thickness-mode or spherical); micromachined ultrasound transducer (MUT), such as piezoelectric (pMUT) or capacitive (cMUT); thin film such as PVDF; shear-wave; and combinations of two or more of these.

[0116] Each connected pair of an electrode 132 and an ultrasound transducer 133 can share a single conductor (e.g. a wire or other communication and/or power delivery conduit), such as communication path 134 (e.g. a wire) described herebelow. In some embodiments, multiple pairs of electrode 132 and ultrasound transducer 133 can collectively share a single conductor, communication path 135 (e.g. a wire), also as described herebelow.

[0117] The embodiment of FIG. 1 shows three electrode/transducer pairs per each spline 131a-c (i.e. nine pairs for expandable assembly 130), each pair comprising an electrode 132 and an ultrasound transducer 133. Spline 131a comprises three electrode/ultrasound pairs, 132_i/133_i – 132_{iii}/133_{iii}. Spline 131b comprises three electrode/ultrasound pairs, 132_{iv}/133_{iv} – 132_{vi}/133_{vi}. Spline 131c comprises three electrode/ultrasound pairs, 132_{vii}/133_{vii} – 132_{ix}/133_{ix}. Each electrode/ultrasound pair 132/133 is electrically or otherwise operably connected to a

connection point 136 via a communication path 134, such as when splines 131 include a printed circuit (e.g. a flexible printed circuit), and communication paths 134 can comprise traces on the printed circuit, such as is described in reference to applicant's co-pending United States Patent Application Serial Number 14/762,944, titled "Expandable Catheter Assembly with Flexible Printed Circuit Board (PCB) Electrical Pathways", filed July 23, 2015, the content of which is incorporated herein by reference in its entirety. In various embodiments, such as the embodiment shown in FIG. 1, one or more electrode/ultrasound pairs 132/133 can share a common communication path 135, such as a trace configured as a common ground, electrically or otherwise operably connected to a connection point 136.

[0118] In the embodiment shown, a communication path 134 is connected to an electrode 132, such as electrode 132_i, which is connected to the positive terminal of a paired ultrasound transducer 133, such as ultrasound transducer 133_i. The negative terminal of ultrasound transducer 133_i is connected to common communication path 135. In some embodiments, two or more electrode/ultrasound pairs 132/133 can share a common communication path 135. In some embodiments, each spline 131 can comprise two or more common communication paths 135, such as a spline comprising eight electrode/ultrasound pairs 132/133, comprising two common communication paths 134, each shared by four electrode/ultrasound pairs 132/133.

[0119] A conduit comprising one or more electrical, optical, or electro-optical wires or cables (e.g. coaxial wires), such as conduit 106, can provide a communication path between one or more components of expandable assembly 130, such as one or more electrode/ultrasound pairs 132/133, and handle 110 of catheter 100. Conduit 106 terminates in handle 110 at connector 116. Connector 116 can comprise a jack, plug, terminal, port, or other custom or standard electrical, optical, or electro-optical connector. Conduit 106 can extend distally from handle 110, through one or more lumens of shaft 105, and terminate at the one or more connection points 136. In some embodiments, conduit 106 can comprise multiple coaxial cables, configured to extend through multiple lumens within shaft 105, such as when conduit 106 comprises one coaxial cable per electrode/ultrasound pair 132/133, and the coaxial shields are constructed and arranged to provide a common communication medium (e.g. a ground wire). Two or more coaxial cables can be joined to share a common communication medium, such as four or eight coaxial

cables linked to create a common channel. In some embodiments, a coaxial cable can be used that comprises a gauge greater than 36AWG, such as 42AWG or 46AWG, and can comprise a nominal impedance of less than or equal to 50Ω , and a capacitance of approximately 110pF/m at 1 kHz.

[0120] Electronics module 200 comprises one or more connectors 216, each comprising a jack, plug, terminal, port, or other custom or standard electrical, optical, or electro-optical connector. System 10 can comprise a cable or other conduit, such as cable 206, configured to electrically, optically, and/or electro-optically connect catheter 100 to electronics module 200 via connectors 116 and 216. In some embodiments, electronics module 200 can comprise a patient isolation circuit 201, configured to electrically isolate one or more components of electronics module from Patient P (e.g. to prevent undesired delivery of a shock or other undesired electrical energy to Patient P). Isolation circuit 201 can be integral to electronics module 200 and/or it can comprise a separate discrete component (e.g. separate housing).

[0121] System 10 can further comprise one or more surface electrodes 225, e.g., such as patch electrodes configured to attach to the skin of the patient. Surface electrodes 225 are electrically connected to electronics module 200 via one or more electrical, optical or other conduits, referred to as conduits 226. Surface electrodes can be constructed and arranged to transmit and/or record signals to and/or from Patient P, such as when surface electrodes 225 transmit electrical signals to generate one or more electrical fields within Patient P, such as electrical fields used in a localization procedure as described herein. In some embodiments, system 10 can be configured to generate one or more images based upon information recorded using diagnostic catheter 100, and to correlate cardiac or other electrical activity (e.g. voltage information, dipole information and/or surface charge information) to the one or more images. Alternatively or additionally, system 10 can be configured to correlate cardiac or other electrical activity to one or more images generated using imaging device 80.

[0122] Electronics module 200 comprises electrode transceiver circuitry 210, ultrasound transceiver circuitry 220, and user interface subsystem 230. Electrode transceiver circuitry (ETC) 210 comprises one or more components selected from the group consisting of: a processor, such as a computer processor configured to perform one or more calculations based on data recoded from electrodes 132; at least one filter, such as one or more filters configured to filter one or more data sets

recorded from electrodes 132; at least one signal generator, such as signal generator 211, configured to generate signals used to create a localization field as described herebelow; at least one memory module, such as a memory module configured to store data recorded from electrodes 132; and combinations of these.

[0123] Ultrasound transceiver circuitry (UTC) 220 comprises one or more components selected from the group consisting of: a processor, such as a computer processor configured to perform one or more calculations based on data recorded from ultrasound transducers 133; at least one filter, such as one or more filters configured to filter one or more data sets recorded from transducers 133; at least one signal generator, such as signal generator 221, configured to generate signals used to drive transducers 133 to cause an ultrasonic signal to be produced as described herebelow; at least one memory module, such as a memory module configured to store data recorded from transducers 133; and combinations of these. However, in some embodiments, the ETC 210 and UTC 220 can share components, such as sharing one or more processors and/or one or more memory module.

[0124] User interface subsystem 230 can comprise one or more user input and/or user output components, such as one or more components selected from the group consisting of: a keyboard; a mouse; one or more buttons or switches; a monitor; a touch screen; a speaker; a microphone; a foot pedal; a printer; a transmitter, a receiver, and combinations of these. User interface subsystem 230 can be configured to allow user input, such as to set one or more parameters associated with the operation of system 10. User interface subsystem can be further configured to display information to a user, such as information selected from the group consisting of: electrical cardiac activity information (e.g., dipole density, surface charge density, and/or voltage information, such as, voltage information measured and recorded from electrodes 132 and/or dipole or surface charge density information calculated from data recorded from electrodes 132); device localization (position) data, such as data calculated from data recorded from electrodes 132 and/or other electrodes of system 10; cardiac geometry data, such as geometry data calculated from signals provided by ultrasound transducers 133; one or more images, such as one or more images recorded from imaging device 80 and/or one or more images generated by electronics module 200 (e.g. from data provided by ultrasound transducers 133), such as a text or graphical representation of one or more calculated values by ETC 210 and/or UTC 220; and combinations of these.

[0125] In some embodiments, system 10 can comprise a system constructed and arranged to determine a dipole density map correlating to the distribution of dipole densities on the wall of a heart chamber, and/or a surface charge density map correlating to the distribution of surface charge densities on the wall of a heart chamber such as the system described in applicant's United States Patent Number 8,512,255, titled "Device and Method for the Geometric Determination of Electrical Dipole Densities on the Cardiac Wall", filed August 31, 2012, the content of which is incorporated herein by reference in its entirety. Alternatively or additionally, system 10 can comprise a system constructed and arranged to determine a voltage map, or other diagnostic data set of electrical or anatomic information recorded by catheter 100 and/or calculated by electronics module 200.

[0126] Electrodes 132 can be configured to record electrical activity of the heart chamber, such as by biopotentials (voltages) representing the electrical activity of the heart. Electrodes 132 can be further configured to perform a localization process, comprising recording a voltage caused by an electrical field, such as a localization field generated by surface electrodes 225. Electronics module 200 and ultrasound transducers 133 can be configured to perform an ultrasonically-based distance measurement, comprising transmitting ultrasonic signals from one or more ultrasound transducers 133, and having similar or dissimilar ultrasound transducers 133 record at least the first reflections of the transmitted signals.

[0127] ETC 210 can be configured to process data recorded by electrodes 132 to produce information selected from the group consisting of: the location of individual electrodes 132; the location, current geometry and/or orientation of expandable assembly 130 and its respective components (by processing recorded localization data); the location of one or more additional components or devices present within the heart chamber; electrical activity of a heart chamber, such as dipole density or surface charge density on the wall of the heart chamber or voltages, by processing recorded biopotential data; and combinations of these.

[0128] UTC 220 can be configured to process recorded ultrasound reflection data from ultrasound transducers 133 to produce information selected from the group consisting of: distance from a transducer 133 to a first surface of a heart chamber; distance from an ultrasound transducer 133 to a second surface of a heart chamber; distance between a first surface of a heart chamber and a second surface of a heart chamber (e.g. a heart wall thickness comprising the distance between the

endocardial surface and epicardial surface of a heart chamber); location of one or more anatomic features, such as the pulmonary veins (e.g. pulmonary vein ostia); location of a cardiac valve; other anatomic geometry information; tissue velocity; tissue density; distance from a transducer 133 to a surface of another component of system 10; and combinations of these.

[0129] In some embodiments, a single component (e.g. only a single electrode 132 or a single ultrasound transducer 133) of an electrode 132/ultrasound transducer 133 pair is “activated” at a time (e.g., is provided a signal by electronics module 200 or has its signal recorded by electronics module 200). For example, during the activation period of an ultrasound transducer 133 (e.g. comprising ringing, ringing down, and/or recording), the recording and/or driving of its paired electrode 132 can be disabled (e.g. not performed or ignored). Alternatively, during the activation of an electrode 132 (e.g. driving and/or recording), driving or recording of a paired ultrasound transducer 133 can be disabled (e.g., not performed or ignored). Isolation or activation of either an electrode 132 or an ultrasound transducer 133 of a connected pair can prevent issues that can be caused by an ultrasound transducer 133 drive signal interfering with a localization drive signal (e.g. provided by a surface electrode) and/or a biopotential signal recorded by an electrode 132. In some embodiments, one or more recorded signals are filtered, allowing for simultaneous operation of ultrasound processing and biopotential processing. In some embodiments, system 10 can comprise a standard diagnostic mode, comprising performing biopotential measurements continuously, and interleaving a localization process and an ultrasound measurement process, such as process 500 described in reference to FIG. 2 herebelow. Ultrasound signals can interfere with biopotential signals, and/or biopotential signals can interfere with localization signals. In some embodiments, one or more processes (localization, ultrasound, and biopotential measurements) can be interleaved with one or more other processes, such that an individual process (or combination of processes) does not cause interference with a separate process (or combination of processes).

[0130] During an operational mode, such as a diagnostic mode as described in FIG. 2 herebelow, the activation period of a transducer 133 causes a “blanked” period for paired electrode 132, causing a temporary “blind spot” of biopotential measurement. As described in reference to FIG. 4 herebelow, a sequencing of

transducers 133 can be performed, such that the temporary "blind spot" is not extended by sequentially activating adjacent or otherwise proximate pairs 132/133.

[0131] In some embodiments, a sequence is performed as follows. During an ultrasound measurement process, all electrodes 132 can actively record biopotential signals. A first transducer 133_i can be activated, as described herebelow in reference to FIG. 4, causing a "blinking" of paired electrode 132_i. Following the activation of transducer 133_i, transducer 133_v can be activated, followed by 133_{ix}, 133_{ii}, 133_{vi}, 133_{viii}, 133_{iii}, 133_{iv}, and 133_{vii}. In this embodiment, the "blind spot" created by the "blinking" of paired electrodes 132 follows the same pattern, moving non-sequentially about expandable assembly 130, and minimizing any potential data integrity loss due to the blind spots created.

[0132] In some embodiments, system 10 comprises one or more sensors, each configured to produce a signal, such as sensor 59 of introducer 50, a sensor of diagnostic catheter 100 (e.g. sensor 119 of handle 110 or sensor 139 of array 130), a sensor 209 of electronics module 200 and/or a sensor 89 of imaging device 80, each as shown in Fig. 1. In some embodiments, system 10 comprises two or more of sensors 59, 119, 139, 209 and/or 89. In some embodiments, sensors 59, 119, 139, 209 and/or 89 comprise a sensor selected from the group consisting of: a force sensor; a pressure sensor; a strain gauge; an optical sensor; an imaging sensor (e.g. a lens or optical fiber); a sound sensor such as an ultrasound sensor; a hall effect sensor; a pH sensor; a magnetic sensor; a temperature sensor; and combinations of one or more of these. In some embodiments, sensors 59 and/or 139 comprise a patient physiologic sensor, such as a sensor selected from the group consisting of: a blood pressure sensor; a blood gas sensor; a temperature sensor; a blood glucose sensor; a pH sensor; a respiration sensor; an average clotting time (ACT) sensor; and combinations of one or more of these. In some embodiments, system 10 is configured to analyze a signal produced by one, two or more of sensors 59, 119, 139, 209 and/or 89. In some embodiments, system 10 (e.g. electronics module 200 and/or an algorithm of ETC 210) is configured to perform an analysis of one or more signals produced by one, two or more of sensors 59, 119, 139, 209 and/or 89 in combination with voltage data, dipole density data, surface charge data, and/or anatomical data (e.g. anatomical data collected by one or more ultrasound transducers 133). In some embodiments, signals from one or more sensors 59, 119, 139, 209 and/or 89 are used by system 10 to perform a function selected from the

group consisting of: improve an anatomical image displayed by system 10; improve cardiac information displayed by system 10 (e.g. dipole density and/or surface charge information); detect a malfunction of system 10; provide physiologic data of a patient; and combinations of one or more of these. In some embodiments, one or more of sensors 59, 119, 139, 209 and/or 89 can comprise a transducer (e.g. as an alternative to being a sensor or in addition to being a sensor), such as a transducer selected from the group consisting of: a heating element; a cooling element; a vibrating element; a drug or other agent delivery element; a magnetic field generating element; a light delivery element; an imaging element (such as a lens, and/or optical fiber); and combinations of one or more of these.

[0133] Referring now to FIG. 2, provided is an embodiment of a method of performing a diagnostic assessment, consistent with the present inventive concepts. In some embodiments, process 500 of FIG. 2 is accomplished using system 10 of FIG. 1 described hereabove. In STEP 510, a diagnostic catheter 100 is inserted into a heart chamber of a patient P. Further processes can be performed in order to prep the patient for a diagnostic procedure, such as a process selected from the group consisting of: applying one or more surface electrodes 225 to the patient; preparing one or more alternate imaging devices, such as imaging device 80 described hereabove; delivery of one or more drugs or other agents to the patient, such as a heart medication or blood thinner; preparing ETC 210 for use; and combinations of two or more of these.

[0134] In STEP 520, the system 10 is placed in a diagnostic mode. The diagnostic mode can be configured to produce one or more images or sets of information correlating to the anatomical shape and/or configuration of a heart chamber, and/or the electrical activity of a heart chamber, such as mapping information gathered prior to and/or during a cardiac ablation procedure. The diagnostic mode can comprise STEPS 530, 540, and 550, performed repeatedly, simultaneously, or in a particular pattern, as described herein.

[0135] In STEP 530, system 10 performs an analysis of biopotential data, determining dipole, surface charge and/or other voltage or charge based information correlating to the electrical activity of the heart, such as described in United States Patent Number 8,417,313, entitled "Method and Device for Determining and Presenting Surface Charge and Dipole Densities on Cardiac Walls," which is incorporated herein by reference. Electrodes 132 are electrically connected to ETC

210 of electronics module 200 via conduits 106 and cables 206. ETC 210 can comprise one or more algorithms for determining dipole density and/or surface charge based on data recorded from electrodes 132. ETC 210 can further comprise one or more filters (e.g. hardware or software filters), configured to pass (e.g. not significantly filter) biopotential signals, while filtering other signals, specifically ultrasound and/or localization signals present within the chamber of the heart or otherwise within Patient P. In some embodiments the processes of STEP 530 can be continuously performed during the completion and/or repetition of STEPS 540 and 550, such as continuously while system 10 remains in a diagnostic mode.

[0136] In STEP 540, a localization process is performed, such as a localization process described below with reference to FIG. 3.

[0137] In STEP 550, an ultrasound measurement process is performed, such as an ultrasound measurement process described below in reference to FIG. 4.

[0138] In Step 560, if system 10 remains in a diagnostic mode, STEPS 530, 540, and 550 are repeated. In some embodiments, such as when STEP 530 is continuously performed while system 10 remains in a diagnostic mode, STEPS 540 and 550 are repeated continuously while system 10 remains in a diagnostic mode. In some embodiments STEP 540 can be performed for longer, or multiple times for a single STEP 550. In some embodiments STEP 550 can be performed for longer, or multiple times for a single STEP 540.

[0139] System 10 can be placed in an alternate mode, such as a mode selected from the group consisting of: a hold mode, such as a mode when catheter 100 remains inserted in Patient P, however diagnostic procedures are not performed; an alert mode, such as a mode when system 10 has detected an error and diagnostic and/or other procedures are halted; a shutdown/completion mode, such as a mode when system 10 is deactivated, such as to be removed from Patient P at the end of a diagnostic or treatment procedure. In STEP 560, when system 10 is determined to no longer be in a diagnostic mode, process 500 enters STEP 570. In STEP 570, all diagnostic procedures are stopped.

[0140] In some embodiments, system 10 can alternate between STEP 540 and STEP 550, such as to gather localization information and ultrasound information to generate a model of the anatomy of the heart. Subsequently, STEP 530 and STEP 540 can be performed, alternatingly or simultaneously, such as to map the electrical activity of the heart, such that system 10 can register the mapped electrical

activity to the modeled anatomy gathered previously. In some embodiments, system 10 can again alternate between STEP 540 and STEP 550 to update the model of the anatomy.

[0141] Referring now to FIG. 3, provided is an embodiment of a method of performing a localization process, consistent with the present inventive concepts. In some embodiments, process 600 of FIG. 3 is accomplished using system 10 of FIG. 1 described hereabove. In STEP 610, system 10 begins a localization process. In some embodiments this process can be interleaved with an ultrasound measurement process as described below with reference to FIG. 4.

[0142] In STEP 620, signal generator 211 generates one or more localization signals, transmitted to patient P through one or more surface electrodes 225 via conduits 226. Surface electrodes 225 can comprise one or more pairs of electrodes 225, such as three pairs of electrodes 225, configured to provide a three axis localization system. For example, in a three axis localization configuration, pairs of surface electrodes 225 can be placed on patient P; a first pair placed on the chest and back of patient P defining a first, X axis; a second pair placed laterally on the sides of patient P defining a second, Y axis; and a third pair placed on the neck or shoulder and thigh of patient P, defining a third, Z axis. Alternatively, a first pair of electrodes can be placed laterally on the sides of the patient defining a first axis, a second pair of electrodes can be placed on the upper chest and lower back of the patient defining a second axis, and a third pair of electrodes can be placed on the upper back and lower chest of the patient, defining a third axis. In some embodiments, signal generator 211 generates 3 or more signals of different frequencies, such as to drive three or more axes (e.g. each axis X, Y, and Z described hereabove), each at a unique frequency. The three or more axes can comprise two or more axes that are orthogonal to each other. Alternatively or additionally, signal generator 211 can generate 3 signals which differ in phase or other measurable characteristics, such that each signal (axis) can be determined via filtering to perform multi axis localization as describe herebelow. In some embodiments, each axis is powered individually (e.g. one at a time), and single axis localization can be interleaved between one or more desired axes. In the embodiment of process 600, STEP 620 can be performed continuously, throughout process 600, or throughout a diagnostic procedure (e.g. localization signals are continuously driven throughout the diagnostic procedure).

[0143] In STEP 630, ETC 210 records data collected from one or more electrodes 132, such as from each electrode 132 simultaneously or sequentially. In STEP 640, the recorded data can be filtered one or more times, such as by one or more sequential filters and/or one or more parallel filters. In an embodiment, the recorded data can be initially filtered to isolate signals correlating to the localization signals generated by generator 211, such as signals comprising a frequency between 1 and 100 kHz, such as between 10 and 100 kHz. The filtered data can subsequently be split and filtered by multiple (e.g. three) parallel filters, each configured to isolate a single frequency range, such as a frequency range associated with a single axis.

[0144] In STEP 650, the three sets of individually filtered data can be analyzed, for example by a localization algorithm, such as to determine the location of each electrode 132, in a three dimensional coordinate system relative to Patient P. In some embodiments, localization process 600 can comprise the use of more or fewer axes, such as two, three, or four axes. Additionally or alternatively, localization process 600 can comprise the use of concentric surface electrodes 225. Localization process 600 can comprise multiple filters and/or multiple data paths within ETC 210, such as multiple data paths corresponding to multiple axes, and multiple levels of data filtering.

[0145] In STEP 660, if system 10 remains in a localization process, STEPS 620 through 650 are repeated. In some embodiments system 10 can remain in a localization process for a time period between 1 μ s and 1s, such as between 50 μ s and 0.5s, such as approximately 10ms, for example when localization process 600 is interleaved with an ultrasound measurement process and each process is performed during similar or dissimilar amounts of time. In STEP 660, when system 10 is determined to no longer be in a diagnostic mode, process 600 enters STEP 670. In STEP 670, the localization 600 process is stopped.

[0146] Referring now to FIG. 4, provided is a method of performing an ultrasound measurement process, consistent with the present inventive concepts. In some embodiments, process 700 of FIG. 4 is accomplished using system 10 of FIG. 1 described hereabove. In STEP 710, system 10 begins an ultrasound measurement process. In some embodiments this process can be interleaved with a localization process as described in reference to FIG. 3 hereabove.

[0147] In STEP 720, UTC 220 “activates” a first transducer 133 (which can be referred to as 133_{FIRST}), such as by closing one or more switches, electrically connecting the first transducer 133_{FIRST} to generator 221 and/or other electrical components of UTC 220, such as is described in reference to FIG. 6 herebelow. In some embodiments, the one or more switches can comprise an opto-coupler, such as an opto-coupler with an activation time of approximately 0.01 μ s, or approximately 500 μ s. Generator 221 can be configured to generate a pulsed “drive signal”, configured to “ring”, vibrate, and/or otherwise cause transducer 133 to generate an ultrasonic pulse. The drive signal can comprise a signal with one or more frequencies between 1 MHz and 25 MHz, such as a drive signal with at least a frequency of approximately 10 MHz. The drive signal can further comprise a signal comprising a pulse width between 0.1 μ s and 10 μ s, such as a pulse width of approximately 1.0 μ s or 2.0 μ s.

[0148] In some embodiments, such as the paired electrode/transducer embodiment of FIG. 1, the activation of a transducer 133 causes the deactivation of its paired electrode 132. During the activation period of a transducer 133, ETC 210 does not record electrical signals received by the paired electrode 132, causing a temporary “blind spot”. As described herebelow, a non-sequential sequence of transducers 133 can be activated, such that the temporary “blind spot” in electrical recording is not extended by sequentially activating adjacent pairs 132/133.

[0149] In STEP 730, first transducer 133_{FIRST} remains activated, however is no longer being driven by generator 221. Transducer 133 “rings down” (or is “rung down”), such as to allow all driven vibration of first transducer 133_{FIRST} to cease and any remnant vibrations within first transducer 133_{FIRST} to dissipate. In some embodiments, STEP 730 can comprise a duration of between 0.05 μ s and 1 μ s, such as a duration of approximately 0.1 μ s.

[0150] In STEP 740, UTC 220 is configured to “listen”, such as by recording any ultrasonic vibrations sensed by first transducer 133_{FIRST}, and recording reflections of one or more ultrasonic pulses generated in STEP 720. These reflections can correlate to reflections of ultrasound off of features or structures selected from the group consisting of: an inner wall of the cardiac chamber; an outer wall of the cardiac chamber; a feature of the cardiac chamber, such as a pulmonary vein or cardiac valve; a portion of a device inserted into the cardiac chamber, such as an ablation catheter and/or second mapping catheter also inserted into the

cardiac chamber; and combinations of two or more of these. In some embodiments, STEP 740 can be configured to “listen” for reflections during a time period of between $1\mu\text{s}$ and $200\mu\text{s}$, such as a time period of approximately $100\mu\text{s}$. UTC 220, or another component of electronics module 200, can be configured to determine a distance measurement, such as a measured distance from first transducer 133_{FIRST} to the source of the first received reflection, such as a reflection from the inner wall of the cardiac chamber. The distance measurement can be determined using techniques commonly known to those skilled in the art, such as by determining the total “travel time” of the ultrasonic pulse, and using the speed of sound in blood and/or other tissue (as appropriate) to determine the total travel distance of the pulse.

[0151] In STEP 750 a subsequent transducer, 133_{NEXT} can be electronically prepared. Preparation can include “activating” transducer 133_{NEXT}, as described hereabove. STEP 750 can further comprise the deactivation of the previous transducer 133_{PREV}, for example transducer 133_{FIRST}. In some embodiments, activation of transducer 133_{NEXT} can comprise a process requiring a duration of between $0.01\mu\text{s}$ and $500\mu\text{s}$, such as a duration of approximately $50\mu\text{s}$. In these embodiments, the activation of transducer 133_{NEXT} can be interleaved with a deactivation of the previous transducer 133_{PREV}, and/or with a portion of STEP 740, such that transducer 133_{NEXT} is being activated while transducer 133_{PREV} is listening and or being deactivated. In some embodiments, these processes can overlap for a time period of between $0.01\mu\text{s}$ and $500\mu\text{s}$, such as a time period of approximately $100\mu\text{s}$. In some embodiments, the duration from the start of an activation process of a transducer 133 to the end of a deactivation process can be between $1\mu\text{s}$ and $700\mu\text{s}$, such as a duration of approximately $200\mu\text{s}$.

[0152] In STEPS 760 through 780, transducer 133_{NEXT} is rung, rung down, and listened to and recorded, as described in reference to STEPS 720 through 740 hereabove.

[0153] In STEP 790, if all transducers 133 (or a predetermined subset thereof) have not been activated since the start of process 700, STEPS 750 through 790 are repeated. In some embodiments, a subset of transducers 133 are activated per process 700, such as approximately half or approximately one third of the transducers 133, such as when two or three cycles of process 700 are required to activate all transducers 133, such as two or three cycles run sequentially or are

interleaved with one or more other processes, such as process 600 of Fig. 3. In some embodiments, a complete cycle, such as a cycle in which all transducers 133 are activated, can comprise a duration of between 500 μ s and 10,000 μ s, such as a duration of approximately 5,000 μ s. In the embodiment of Fig. 5 described herebelow, catheter 100 can comprise 48 transducers 133. Each activation period can comprise a duration of approximately 200 μ s, and process 700 can comprise a duration of approximately 5ms.

[0154] In STEP 790, if all transducers 133 (or a predetermined subset thereof) have been activated, process 700 continues to STEP 795. In STEP 795, if the measurement process is to be repeated, for example if a subsequent (similar or dissimilar) subset of transducers 133 is to be activated, STEPS 720 through 790 are repeated. If the measurement process is completed, process 700 enters STEP 799. In STEP 799, the measurement process is stopped.

[0155] Referring now to FIG. 5, provided is a perspective view of an embodiment of a diagnostic catheter that includes expandable assembly 130, consistent with the present inventive concepts. The expandable assembly 130 can be, in whole or in part, in accordance with the description of United States Patent Application Serial Number 14/762,944, entitled "Expandable Catheter Assembly with Flexible Printed Circuit Board (PCB) Electrical Pathways", filed July 23, 2015, which is incorporated herein by reference. In the embodiment of FIG. 5, the expandable assembly 130 includes a plurality of splines 131 configured as shown (i.e., six splines, radially separated by 60°, each spline comprising eight electrode transducer pairs 132/133). In this embodiment, transducers 133 are coupled to splines 131 using a housing 138. In other embodiments, multiple transducers 133 can be coupled to splines 131 (e.g. between two and twelve splines 131) in different manners.

[0156] In this embodiment, an array of transducers 133 and electrodes 132 are substantially equally distributed across splines 131, as shown in the expanded state of expandable assembly 130. Proximal ends (nearest shaft 105) of splines 131 are attached to a distal portion of shaft 105, such as at a location in and/or within shaft 105, or between shaft 105 and an inner, translatable (i.e. advanceable and retractable) shaft, control rod 107. Control rod 107 can comprise one or more conduits and/or passageways, such as lumen 108 as shown. Lumen 108 can be configured to allow for catheter 100 to be inserted over a guidewire, such as when

lumen 108 is sized to slidingly receive a guidewire, and lumen 108 continues to a proximal portion of catheter 100, such as when lumen 108 exits handle 110 of catheter 100. Additionally or alternatively, lumen 108 can be sized to slidingly receive one or more devices such as a device selected from the group consisting of: an ablation catheter; a mapping catheter; a cryo ablation catheter; a tip ablation catheter; a diagnostic catheter; and combinations of two or more of these. In some embodiments, lumen 108 can be configured to allow for the delivery of one or more drugs or other agents during a diagnostic or other procedure.

[0157] In some embodiments, electrodes 132 can be positioned on the inside of splines 131. Alternatively or additionally, electrodes 132 can comprise some electrodes positioned on the inside of splines 131 and some electrodes positioned on the outside of spline 131. Alternatively or additionally, electrodes 132 can be double sided electrodes, with opposing surfaces facing both inward and outward of the basket, or electrodes 132 can comprise ring-shaped electrodes, surrounding each spline 131 respectively.

[0158] As shown, distal ends of splines 131 are connected to the distal end of control rod 107. Control rod 107 can be advanced and retracted to compact and expand, respectively, expandable assembly 130. Control rod 107 can be advanced and retracted via a control on a proximal handle, such as control 111 on handle 110 of Fig. 1. In some embodiments, control rod 107 can be retracted from a position correlating to the natural expanded position of expandable assembly 130 (as shown by example in FIG. 5), such as to deform expandable assembly 130, such as to invert a distal portion of splines 131, resulting in at least the distal most transducers 133 aligning in a forward facing direction, as shown in FIG. 5A. In this configuration, the forward facing transducers 133 can be used as an array of transducers to perform B mode scans, or other ultrasound scanning methods known in the art.

[0159] As described herein, expandable assembly 130 of FIG. 5, including forty eight electrode/transducer pairs 132/133, can be used to perform biopotential measurements, localization measurements, and/or ultrasound distance measurements. During an ultrasound measurement process, such as process 700 of Fig. 4 described hereabove, transducers 133 of expandable assembly 130 of FIG. 5 can be sequenced as described herebelow in reference to FIG. 6.

[0160] Referring now to FIG. 6, a representation of an activation sequence of an array of 48 ultrasound transducers disposed on six splines (8 per spline) is

illustrated, consistent with the present inventive concepts. FIG. 6 is a particular representation of an activation sequence, representing a specific number of transducers, substantially equally spaced across a specific number of splines on an expandable assembly, such as expandable assembly 130 of FIG. 5 hereabove. Alternatively, expandable assembly 130 can have different numbers of transducers and/or splines, and a similar or dissimilar non-sequential sequence of transducer activation can be performed.

[0161] In the embodiment of FIG. 6, transducers 1 – 8 represent a most distal (1) transducer through a most proximal transducer (8), across each of six splines. Each activation period depicted by a solid box represents a period of activation and as described herein, a deactivation or blanking of a paired electrode. The pattern shown represents a pattern avoiding the sequential activation of two neighboring transducers, such as a pattern avoiding the sequential activation of two transducers within two or three “neighboring spaces” of each other. Neighboring spaces can be considered spaces on a single spline; across splines, such as transducer 1 of spline 1 and transducer 1 of spline 2; and/or diagonally across splines, such as transducer 1 of spline 1 and transducer 2 of spline 2. The pattern shown also represents a pattern avoiding sequential activation of two transducers from a single spline.

[0162] FIG. 7 provides an embodiment of a block diagram of a user interface (UI) system 230 that can be used with a diagnostic catheter as described herein, for example, in accordance with the present inventive concepts.

[0163] The UI system 230 includes a display area 240, which can include one or more windows, screens, and/or monitors on which information can be rendered/shown, e.g., as 2D or 3D displays. The windows in the display area 240 need not be arranged nor relatively sized as shown in FIG. 7. And not all windows shown in display area 240 must be included. The depiction in FIG. 7 represents an illustrative embodiment, but a UI system in accordance with the inventive concept is not limited to the particular embodiment shown.

[0164] A 3D display window 242 can be included to show graphical elements in a three-dimensional (3D) space, such as a heart or heart chamber. The images and information rendered in the 3D display window 242 can change based on the user task being performed, e.g., based on the task being done in a main application window 250. The 3D display window 242 can also exist within the main application

window 250, in some embodiments. The 3D display window 242 can be user interactive, and can change in response to the user interaction therewith.

[0165] A two-dimensional (2D) display window 244 can be included to show graphical elements in a two-dimensional space. The images and information rendered in the 2D window 244 can change based on the user task being performed, e.g., based on the task being done in the main application window 250. The 2D display window 244 can also exist within the main application window 250, in some embodiments. The 2D display window 244 can be user interactive, and change in response to the user interaction therewith.

[0166] The main application window 250 can include the primary workflow interface to create 3D maps. An acquisition window 252 provides tools, e.g. user interface tools, necessary to view and record biopotential signals, localization signals, and/or ultrasound signals. One tool of the acquisition window 252 allows ultrasound and localization data to be combined to reconstruct a chamber anatomy (i.e. build a digital model of a surface that represents the chamber anatomy). This representation of the anatomy can be displayed in a surface building window 254. Additionally, previously reconstructed chamber anatomies (e.g. of the patient and/or a surrogate) can be loaded from one or more data repositories, such as files, databases, or memory and displayed in the surface building window 254 to be used with live data. Configuration settings are available from this window 254 to properly register/orient a chamber reconstruction to the live data.

[0167] A waveform processing window 256 can be provided and used to allow recorded data to be reviewed, filtered, and/or analyzed. The user can use these tools to identify a time segment of data to be mapped. Segments can be from 1 sample in length to the full recorded data length. Segment selection can also take the form of passing data directly, time sample by time sample, to the mapping algorithm such that maps can be made “on the fly” (e.g. in real-time or near real-time, or pseudo real-time, “real-time” herein), without manual segment selection. The waveforms being processed can be shown in the 2D display window 244, e.g., in the form of an electrogram (EGM) or electrocardiogram (ECG or EKG). The 3D display window 242 can show any or all of the following: the voltage signals on the basket electrodes rendered onto a three-dimensional surface of the size and shape of the basket, a colored topographic surface showing the electrode signals (color and “Z-height” of the topography corresponding to voltage amplitude), with electrodes

oriented in relative neighbor relationship, and/or the spatial position of the basket in relation to the reconstructed surface to show the basket position within the chamber of interest.

[0168] A mapping window 258 can be provided and used to allow configuration and execution of the mapping algorithms, including selection of a surface source model. The resulting 3D maps can be rendered in the 3D display window 242 with corresponding waveforms shown in the 2D display window 244. A time cursor or window can be included to provide a time index between display windows. The time cursor or window can be configured to slide or move across the waveforms in the 2D window in synch with a dynamically changing display rendered in the 3D window.

[0169] A system configuration and diagnostic window 246 can be provided and used to show live signals from the catheters (e.g., processed through electronics module 200) – biopotential, localization, and/or ultrasound, as examples. This window 246 can be used for verification of operation of such systems or subsystems.

[0170] A surface editing window 248 can be provided and used to allow the user to edit and process the reconstructed anatomy. Tools provided can include but are not limited to: selection (individual vertices/polygons, rectangular, elliptical, free-form shape, automatic isolated component selection and/or sharp feature selection), trimming (through-cut, front-surface cut), smoothing, re-meshing, hole-filling, subdivision, and surface deformation, such as push-pull, tools. These tools can include shape identification, component identification, isolation, extraction, appending and/or merging tools. These tools can be user interactive surface editing tools. These tools can be configured to operate manually, semi-automatically and/or automatically.

[0171] A user input module 260 can include human interface devices, such as mouse, keyboard, touchscreen, digital pen, or other devices that can be used to provide user input to and/or control of the system and its renderings.

[0172] FIGS. 8A – 8C provide different views relating to the output of the user interface system, in accordance with aspects of the present inventive concepts.

[0173] Referring to FIG. 8A, a point cloud (PointCloud) data structure is shown, which can be rendered in the 3D display window 242. According to this embodiment, the 3D coordinate space is divided into spherical sectors with quadrilateral cross-sections, except the poles which are N-sided. The cross-section of each bin at the same radius from the origin is configured to be similar in area.

Surface point coordinates fall into one and only one bin, so do not overlap. Bin size, e.g., subtended azimuth or elevation angle, can be configurable (e.g. on instantiation). To change bin-size (and thus mesh size) and/or displacement of the surface relative to the center of the spherical bins, all surface points in an existing PointCloud can be placed into a second data structure with the desired parameters in one bulk operation.

[0174] A surface representative of the surface points in the data structure is displayed by merging all representative points or surface of each bin. In one embodiment, the representative vertices can be drawn with the interconnecting mesh between bins to form the surface. As points are added to the data structure, bins will be updated and the representative surface is updated correspondingly. Bins with no points within them can be hidden from display.

[0175] Referring to FIG. 8B, a PointCloud bin is shown and described with reference to a 3D rendering of a heart. All data points falling in each bin are analyzed to determine a representative point (vertex) or surface (surface patch) for the bin. In one embodiment, the centroid of all points in the bin is used as a representative vertex. Data within each bin can be assessed for quality, and vertices or polygons of the representative surface can be colored to indicate quality of the data. In one embodiment, the dispersion or radial distance variance in the data can indicate the detection of a cardiac valve, vein, or other radially-oriented anatomical structure.

[0176] Referring to FIG. 8C, a subset of neighboring bins are shown, and their relationships illustrated, where each bin is represented by a block. A non-manifold interconnecting mesh is calculated between neighboring bins. The orientation relationship of bins is static to avoid time-consuming recalculation of the non-manifold interconnecting mesh between neighbors.

[0177] FIG. 9 provides an embodiment of a functional block diagram of a cardiac information processing system 900, in accordance with the present inventive concepts.

[0178] Using the described system from FIG. 9, a user can choose what to calculate and/or what to display, e.g., the user can display Dipole Density (DDM), Charge Density (CDM), or Voltage (V-V). This information is calculated based on information represented in the top three boxes 902, 904, 906, e.g., the position of the electrodes 902, the shape and location of the chamber (surface) 904, and the

potentials recorded at the electrodes 906. The system can also be configured to support and enable changes back and forth between the different display modes, and with post processing tools, can change how that information is displayed.

[0179] The processing includes selecting a forward model 908. Based thereon, one of the following three operations can be performed: Dipole Density Mapping (DDM) 910, Charge Density Mapping (CDM) 912, and/or Voltage to Voltage Mapping (V-V) 914. In Dipole Density Mapping (DDM), electrical fields that could be measured by electrodes inside and/or outside of the heart chamber are generated from a distribution of dipole sources, having a magnitude and direction, on the surface of the heart chamber, organized and arranged as Dipole Densities (DD). In Charge Density Mapping (CDM), electrical fields that could be measured by electrodes inside or outside of the heart chamber are generated from a distribution of scalar charge sources, having a magnitude only, on the surface of the heart chamber, organized and arranged as Charge Densities (CD). And in Voltage to Voltage Mapping (V-V), no source assumption is made, and the voltages measured on electrodes inside or outside of the heart chamber are propagated from the voltages on the heart chamber surface (e.g. using Laplace's equation and/or other methods known to those skilled in electromagnetic field theory).

[0180] With the chamber surface and electrodes' positions registered with the surface as the inputs, the transform matrix, which encodes relationships between the DD/CD/Voltages on the heart chamber to the measured voltages on electrodes, is the output of the forward calculation.

[0181] An Inverse Calculation 916 is performed, with the potentials acquired from the mapping catheter and the transform matrix (the output from the forward calculation) as the inputs, the DD/CD/Voltages on the surface can be obtained by solving a linear system using a regularization method, for example the Tikhonov regularization method.

[0182] DD/CD/Voltages on the surface 920 are outputs from the inverse calculation 916. The surface voltages can be forwardly computed from the derived surface DD/CD for DDM/CDM, and surface voltages from V-V can be used to derive the surface DD/CD using the transform matrix specified by the heart chamber surface.

[0183] In some embodiments, cardiac information processing system 900 comprises post-process tool 930. Using the same, DD/CD/Voltages can be post-

processed to produce a Coulombian map (an adaptation of the discrete Laplacian, or spatial second derivative of the DDM, CDM and/or Voltage maps), IsoChronone map (activation timings), Magnitude map (peak to peak magnitude or negative peak magnitude), Persistence map (active and resting status), and/or Propagation map (the wavefront), as examples.

[0184] The 3D Display 242 can be used to display the outputs from the post-processing tools 930. That is, for example, surface DD/CD/Voltages, as well as post-processing maps, can be rendered by selecting options on the display panel of UI system 230. The 3D maps can be rotated to different viewing angles and a color map can be adjusted by a user, as examples.

[0185] While the foregoing has described what are considered to be the best mode and/or other preferred embodiments, it is understood that various modifications can be made therein and that the invention or inventions may be implemented in various forms and embodiments, and that they may be applied in numerous applications, only some of which have been described herein. It is intended by the following claims to claim that which is literally described and all equivalents thereto, including all modifications and variations that fall within the scope of each claim.

CLAIMS

We claim:

1. A body cavity imaging system, comprising:
a catheter configured for delivery to a body cavity defined by surrounding tissue;
a plurality of ultrasound transducers coupled to a distal end of the catheter;
an electronics module configured to selectively turn on/off each ultrasound transducer according to a predetermined activation sequence and to process signals received from each ultrasound transducer to produce at least a 2D display of the surrounding tissue.
2. The system of claim 1, or any other claim, wherein the imaging system is part of an electrophysiology system.
3. The system of claim 1, or any other claim, wherein the cavity is a heart chamber and the surrounding tissue is one or more walls of the heart chamber.
4. The system of claim 1, or any other claim, wherein the display is a 3D display of the surrounding tissue.
5. The system of claim 4, or any other claim, wherein the 3D display of the surrounding tissue is presented on a user interface system having a display screen and user control mechanism enabling graphical manipulation of the 3D display of the surrounding tissue.
6. The system of claim 5, or any other claim, wherein the graphical manipulation includes one or more of zoom in/out, rotate, select portions or subsections of the surrounding tissue.
7. The system of claim 1, or any other claim, wherein the plurality of ultrasound transducers are coupled to a 3D array.

8. The system of claim 7, or any other claim, wherein the 3D array is a basket array, spiral array, a balloon, radially deployable arms, and/or other expandable and compactible structures.

9. The system of claim 7, or any other claim, wherein the ultrasound transducers are disposed on a plurality of splines of the 3D array.

10. The system of claim 9, or any other claim, wherein the 3D array includes at least three splines.

11. The system of claim 9, or any other claim, wherein at least two ultrasound transducers are disposed on each spline.

12. The system of claim 1, or any other claim, further comprising a plurality of biopotential electrodes coupled to a distal end of the catheter.

13. The system of claim 12, or any other claim, wherein the biopotential electrodes are also disposed on a plurality of splines of the 3D array.

14. The system of claim 13, or any other claim, wherein at least some of the biopotential electrodes and at least some of the ultrasound transducers are disposed on the same splines.

15. The system of claim 13, or any other claim, wherein a biopotential electrode and an ultrasound transducer are disposed together to form an electrode/transducer pair, and the system includes a plurality of electrode/transducer pairs.

16. The system of claim 15, or any other claim, wherein one or more splines comprise at least one electrode/transducer pair.

17. The system of claim 15, or any other claim, wherein one or more splines comprise a plurality of electrode/transducer pairs.

18. The system of claim 15, or any other claim, wherein a plurality of splines comprise at least one electrode/transducer pair.
19. The system of claim 15, or any other claim, wherein a plurality of splines comprise a plurality of electrode/transducer pairs.
20. The system of claim 15, or any other claim, wherein a plurality of splines comprise at least three electrode/transducer pairs.
21. The system of claim 15, or any other claim, wherein each spline comprises a flexible PCB, and each electrode/transducer pair is electrically coupled to the flexible PCB.
22. The system of claim 21, or any other claim, wherein each electrode/transducer pair shares a common communication path on the flexible PCB.
23. The system of claim 21, or any other claim, wherein all electrode/transducer pairs on a spline share a common communication path on the flexible PCB.
24. The system of claim 21 or 22, or any other claim, wherein the common communication path is a common ground.
25. The system of claim 1, or any other claim, further configured to correlate cardiac or other electrical activity to one or more images generated using imaging device.
26. The system of claim 1, or any other claim, wherein the imaging device comprise an imaging device selected from the group consisting of: a fluoroscope; an MRI; a CT Scanner; an ultrasound imaging device; and combinations of two or more of these.

27. The system of claim 1, or any other claim, wherein the activation sequence is a pattern of turning on/off the plurality of ultrasound transducers that avoids the sequential activation of two neighboring ultrasound transducers.

28. The system of claim 28, or any other claim, wherein the activation sequence avoids the sequential activation of two transducers within two or three neighboring spaces of each other.

29. The system of claim 28, or any other claim, wherein the neighboring spaces are spaces on a single spline; across splines, such as transducer 1 of spline 1 and transducer 1 of spline 2; and/or diagonally across splines, such as transducer 1 of spline 1 and transducer 2 of spline 2.

30. The system of claim 27, or any other claim, wherein the activation sequence pattern is a pattern that avoids sequential activation of two transducers from a single spline.

31. A method of performing a diagnostic assessment, comprising:
providing a cardiac diagnostic system, including a plurality of ultrasound transducers and a plurality of electrodes coupled to the end of a diagnostic catheter;
inserting the diagnostic catheter into a heart chamber of a patient;
placing the cardiac diagnostic system in a diagnostic mode;
performing a biopotential measurement process;
performing a localization process;
performing an ultrasound measurement process; and
interleaving a localization process and the ultrasound process.

32. The method of claim 31, or any other claim, wherein frequencies of the ultrasound transducers do not interfere with biopotential signals and biopotential signals do not interfere with localization signals.

33. The method of claim 31, or any other claim, wherein the biopotential measurement process is performed continuously.

34. The method of claim 31, or any other claim, wherein the biopotential measurement process is interleaved with the localization process and the ultrasound measurement process.

35. The method of claim 31, or any other claim, comprising:
performing the localization process longer than, or multiple times for, a single ultrasound measurement process.

36. The method of claim 31, or any other claim, comprising:
performing the ultrasound measurement process longer than, or multiple times for, a single localization process.

37. The method of claim 31, or any other claim, wherein the biopotential measurement process includes measuring and analyzing biopotentials from the electrodes.

38. The method of claim 37, or any other claim, wherein the biopotential measurement process includes determining dipole densities and/or surface charge densities from the biopotential data.

39. A method of performing a localization process, comprising:
providing a cardiac diagnostic system, including a plurality of biopotential electrodes and, optionally, a plurality of ultrasound transducers coupled to a distal end of a catheter;
inserting the diagnostic catheter into a heart chamber of a patient;
placing one or more pairs of surface electrodes on the patient and defining an individual axis for each pair of electrodes;
generating one or more localization signals and transmitting same to the patient through the one or more pairs of surface electrodes;
recording data collected from the one or more pairs of surface electrodes;
filtering the recorded data to isolate signals correlating to the generated localization signals of each pair of surface electrodes; and

analyzing the filtered data to determine a location of each biopotential electrode in a coordinate system relative to the patient, the coordinate system defined by the one or more pairs of surface electrodes.

40. The method of claim 39, or any other claim, wherein there are at least two pairs of electrodes, and one individual axis is determined for each pair of surface electrodes.

41. The method of claim 39, or any other claim, wherein there are at least three pairs of electrodes, and one individual axis is determined for each pair of surface electrodes.

42. The method of claim 41, or any other claim, wherein the three axes define a three axis localization system.

43. The method of claim 39, or any other claim, wherein the coordinate system is a 3D coordinate system.

44. The method of claim 39, or any other claim, wherein an origin of the coordinate system is logically located within the heart of the patient.

45. The method of claim 41, or any other claim, the method comprising:
placing surface electrodes from a first pair of electrodes on the chest and back of the patient, defining a first axis; and/or

placing surface electrodes from a second pair of electrodes laterally on the sides of the patient, defining a second axis; and/or

placing surface electrodes from a third pair of electrodes on the neck or shoulder and thigh of the patient, defining a third axis.

46. The method of claim 41, or any other claim, the method comprising:
placing surface electrodes from a first pair of electrodes laterally on the sides of the patient, defining a first axis; and/or

placing surface electrodes from a second pair of electrodes on the upper chest and lower back of the patient, defining a second axis; and/or

placing surface electrodes from a third pair of electrodes on the upper back and lower chest of the patient, defining a third axis.

47. The method of claim 39, or any other claim, wherein each pair of surface electrodes is individually driven with a signal having a different frequency.

48. The method of claim 39, or any other claim, wherein localization signals are generated at a frequency in a range of about 1-100kHz.

49. The method of claim 39, or any other claim, wherein the signals from each pair of surface electrodes are individually recorded.

50. The method of claim 39, or any other claim, wherein the signals from each pair of surface electrodes are individually filtered.

51. The method of claim 39, or any other claim, wherein the localization process is interleaved with an ultrasound measurement process of the cardiac diagnostic system.

52. The method of claim 39, or any other claim, wherein the localization process is interleaved with a biopotential measurement process of the cardiac diagnostic system.

53. A method of performing an ultrasound measurement process, comprising:

providing a cardiac diagnostic system, including a plurality of ultrasound transducers and, optionally, a plurality of biopotential electrodes coupled to a distal end of a catheter;

inserting the diagnostic catheter into a heart chamber;

activating (or ringing) an ultrasound transducer to generate an ultrasound transducer signal;

ringing down the ultrasound transducer;

sensing and recording a reflection of the ultrasound transducer signal by a source;

determining a distance from the transducer to the source based on the received reflection;

repeating the above steps until all ultrasound transducers have been activated; and

repeating the above steps for all ultrasound transducers until the ultrasound measurement process is complete or ended.

54. The method of claim 53, or any other claim, wherein the biopotential electrodes and ultrasound transducers are paired to form electrode/ transducer pairs.

55. The method of claim 54, or any other claim, wherein the electrode/ transducer pairs are disposed on a plurality of splines of a 3D array.

56. The method of claim 53, or any other claim, wherein activating an ultrasound transducer includes closing one or more switches, thereby electrically connecting the transducer to a signal generator.

57. The method of claim 53, or any other claim, wherein the one or more switches comprises an opto-coupler.

58. The method of claim 53, or any other claim, wherein the opto-coupler has an activation time in a range of about 0.01 μ s, or 500 μ s.

59. The method of claim 53, or any other claim, wherein activating the transducer includes:

generating a pulsed drive signal configured to ring, vibrate, and/or otherwise cause the transducer to generate an ultrasonic pulse.

60. The method of claim 59, or any other claim, wherein the drive signal comprises a signal with a frequency in a range of about 1 MHz and 25 MHz, such as 10 MHz.

61. The method of claim 60, or any other claim, wherein the drive signal frequency is about 10 MHz.

62. The method of claim 59, or any other claim, wherein the drive signal further comprises a signal with a pulse width in a range of about 0.1 μ s and 10 μ s.

63. The method of claim 62, or any other claim, wherein the drive signal pulse width is about 2.0 μ s.

64. The method of claim 53, or any other claim, wherein the ring down has a duration of between about 0.05 μ s and 1 μ s for dissipation of vibration of the ultrasound transducer.

65. The method of claim 64, or any other claim, wherein the ring down has a duration of about 0.1 μ s.

66. The method of claim 53, or any other claim, wherein sensing the reflection is performed for a duration in a range of about 1 μ s and 200 μ s.

67. The method of claim 53, or any other claim, wherein the sensing duration is about 100 μ s.

68. The method of claim 53, or any other claim, wherein the source is an inner wall of a cardiac chamber.

69. The method of claim 53, or any other claim, wherein the activation of the transducer causes deactivation of a paired biopotential electrode.

70. The method of claim 53, or any other claim, further comprising:
non-sequentially activating electrode/ transducer pairs,
thereby not broadening a temporary "blind spot" of a neighboring biopotential electrode caused by the activation of the ultrasound transducer.

71. The system or the method as claimed above, wherein the patient is a living being.

72. The system or the method as claimed above, wherein the patient is a simulated being or heart.

73. A body cavity imaging system as shown and/or described.

74. A cardiac diagnostic system as shown and/or described.

75. A cardiac diagnostic process as shown and/or described.

76. A localization process as shown and/or described.

77. A biopotential measurement process as shown and/or described.

78. An ultrasound imaging method as shown and/or described.

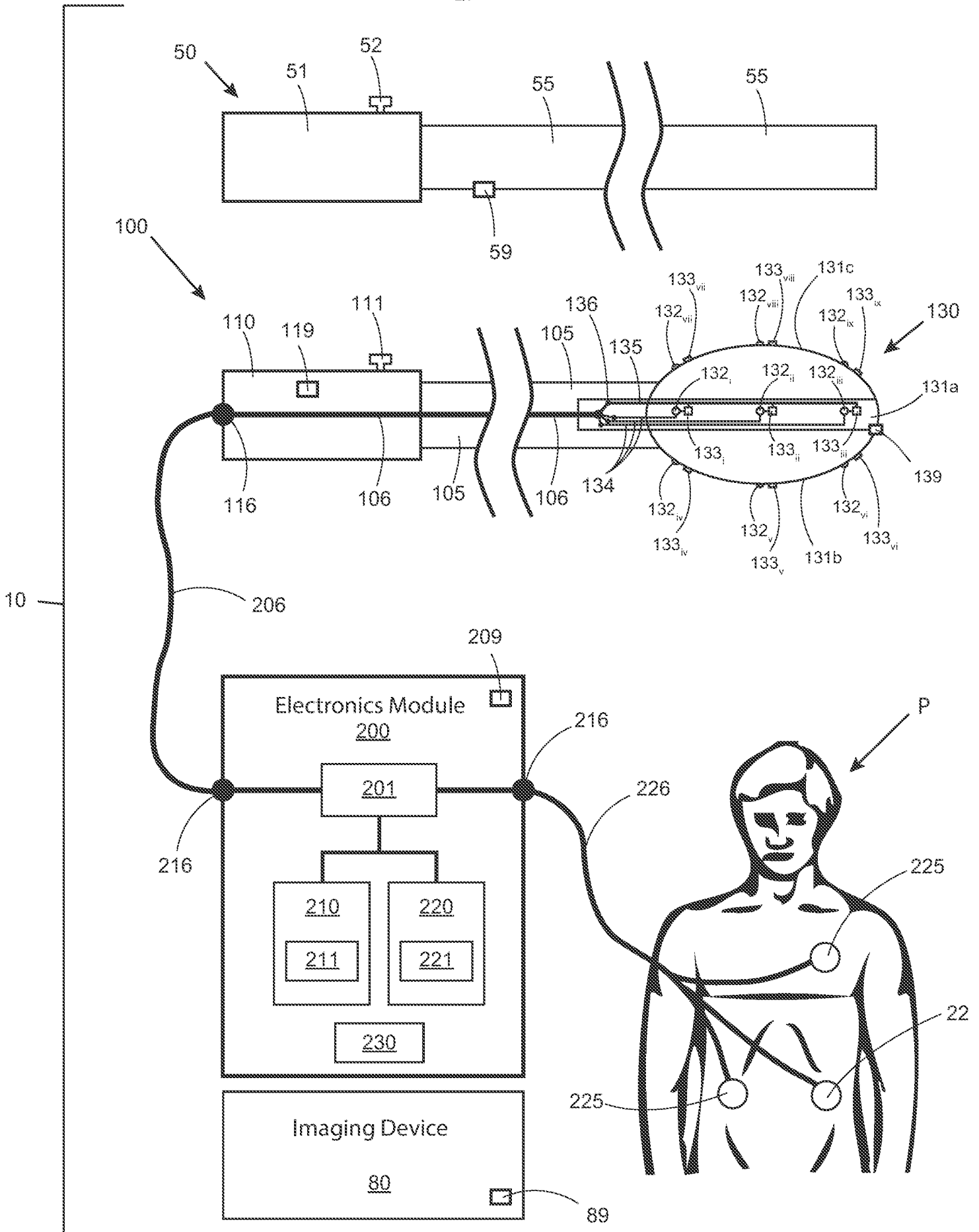

FIG 1

500 ↘

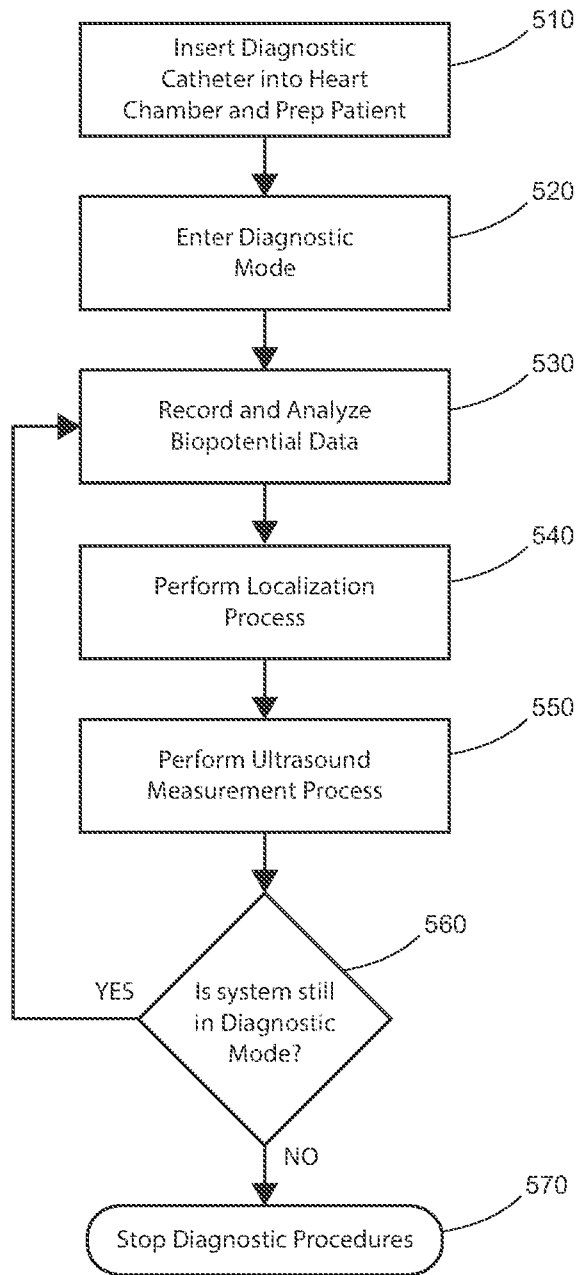

FIG 2

600

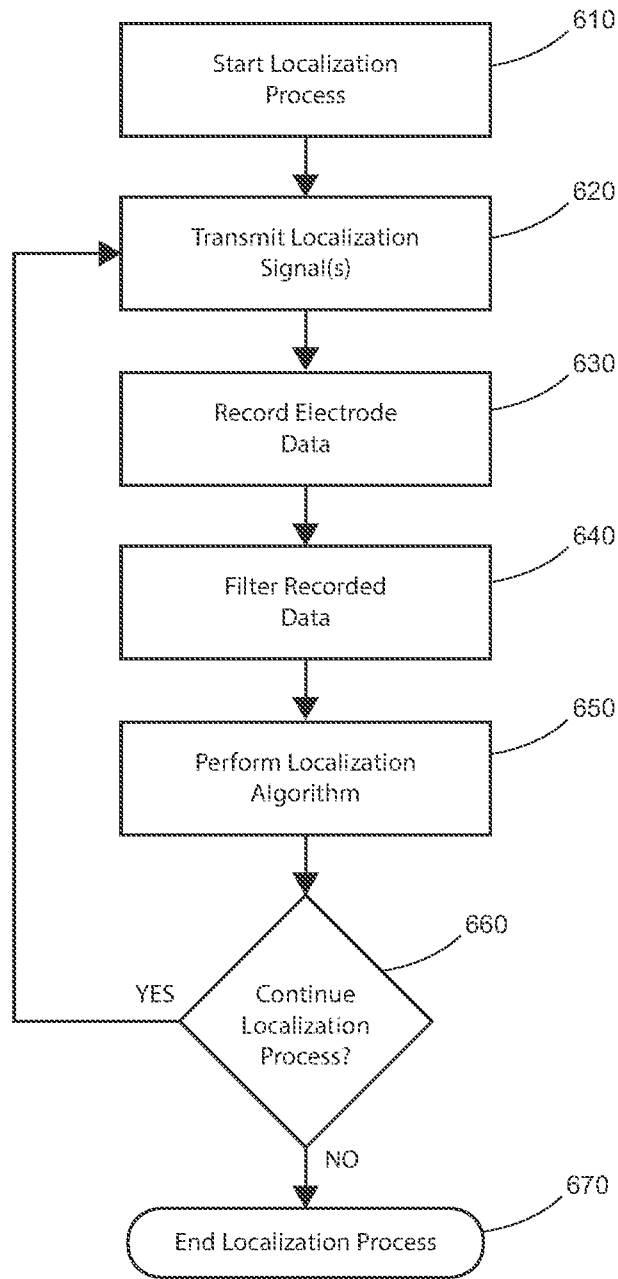

FIG 3

700

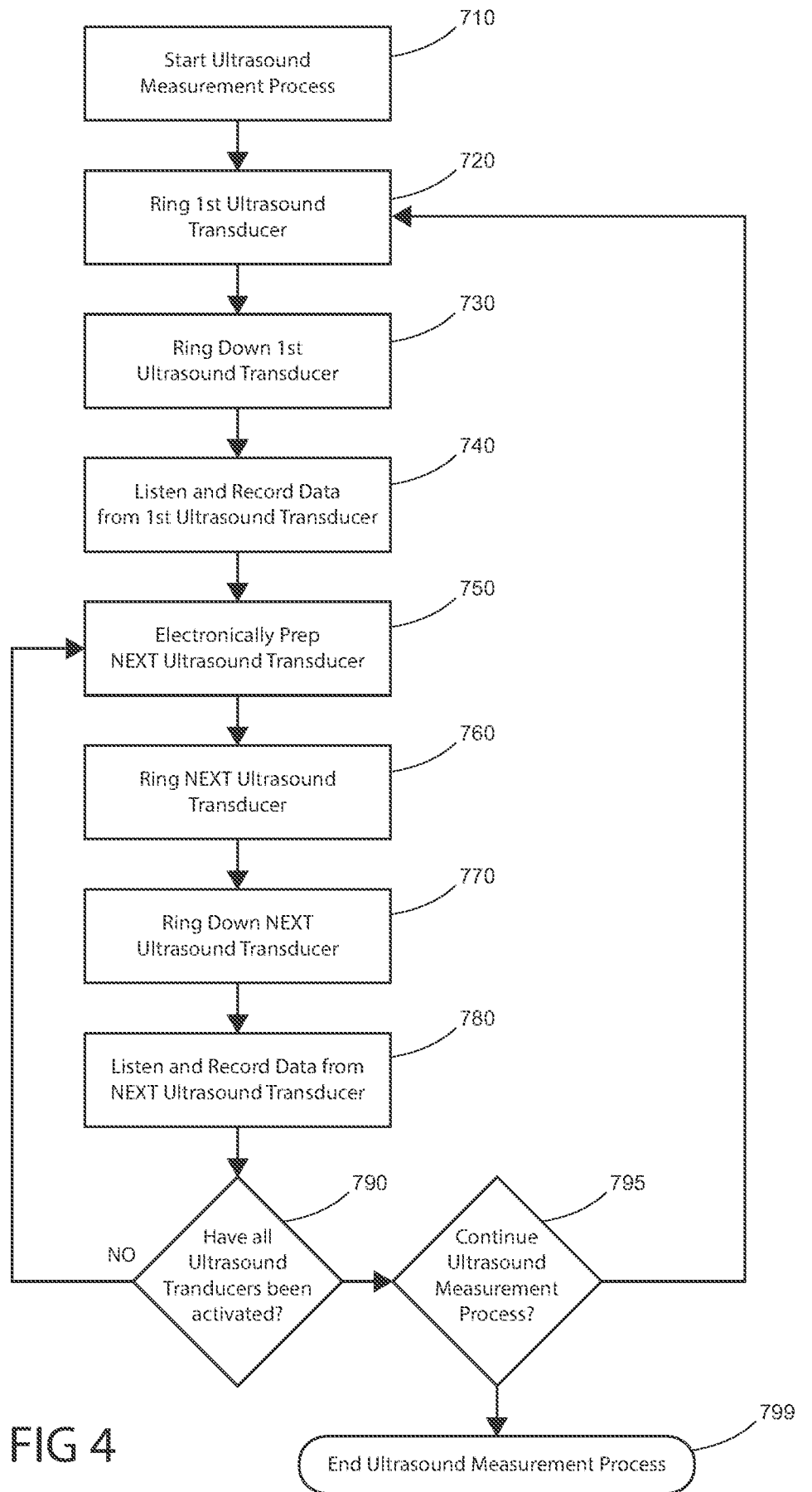

FIG 4

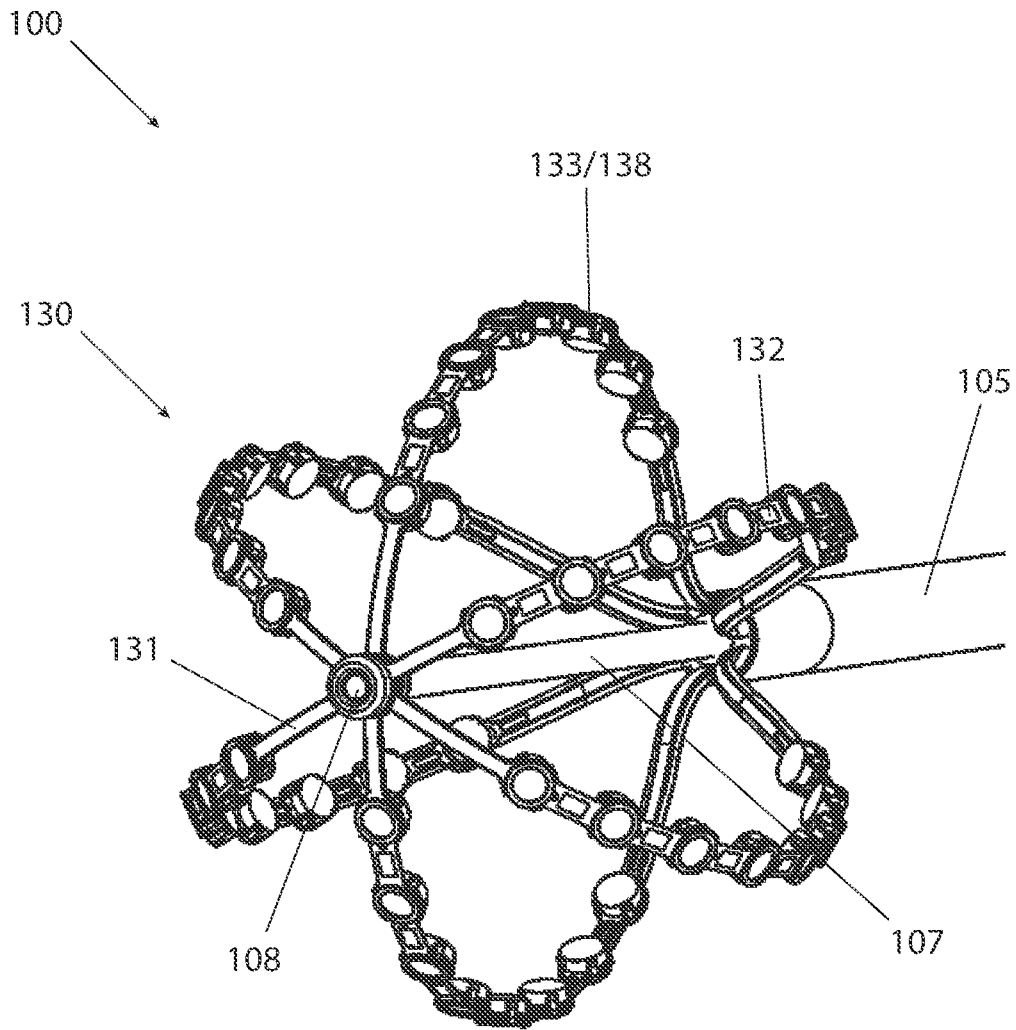

FIG 5

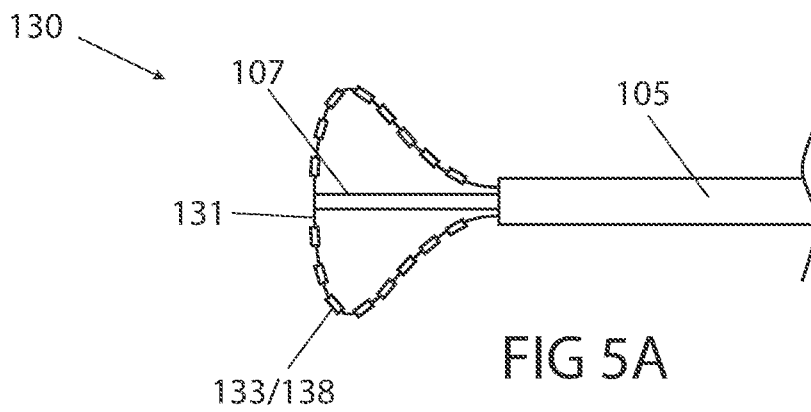

FIG 5A

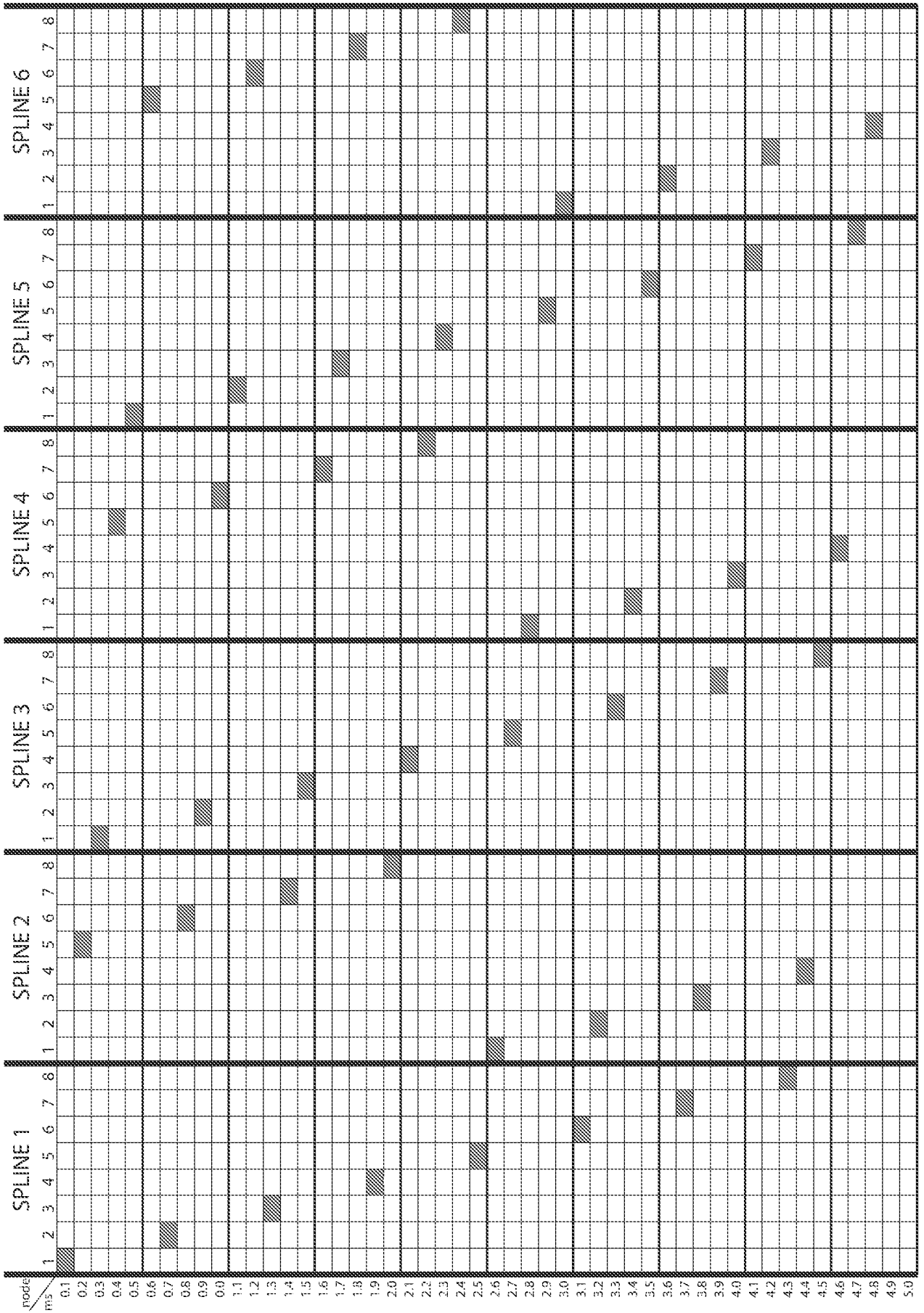

FIG 6

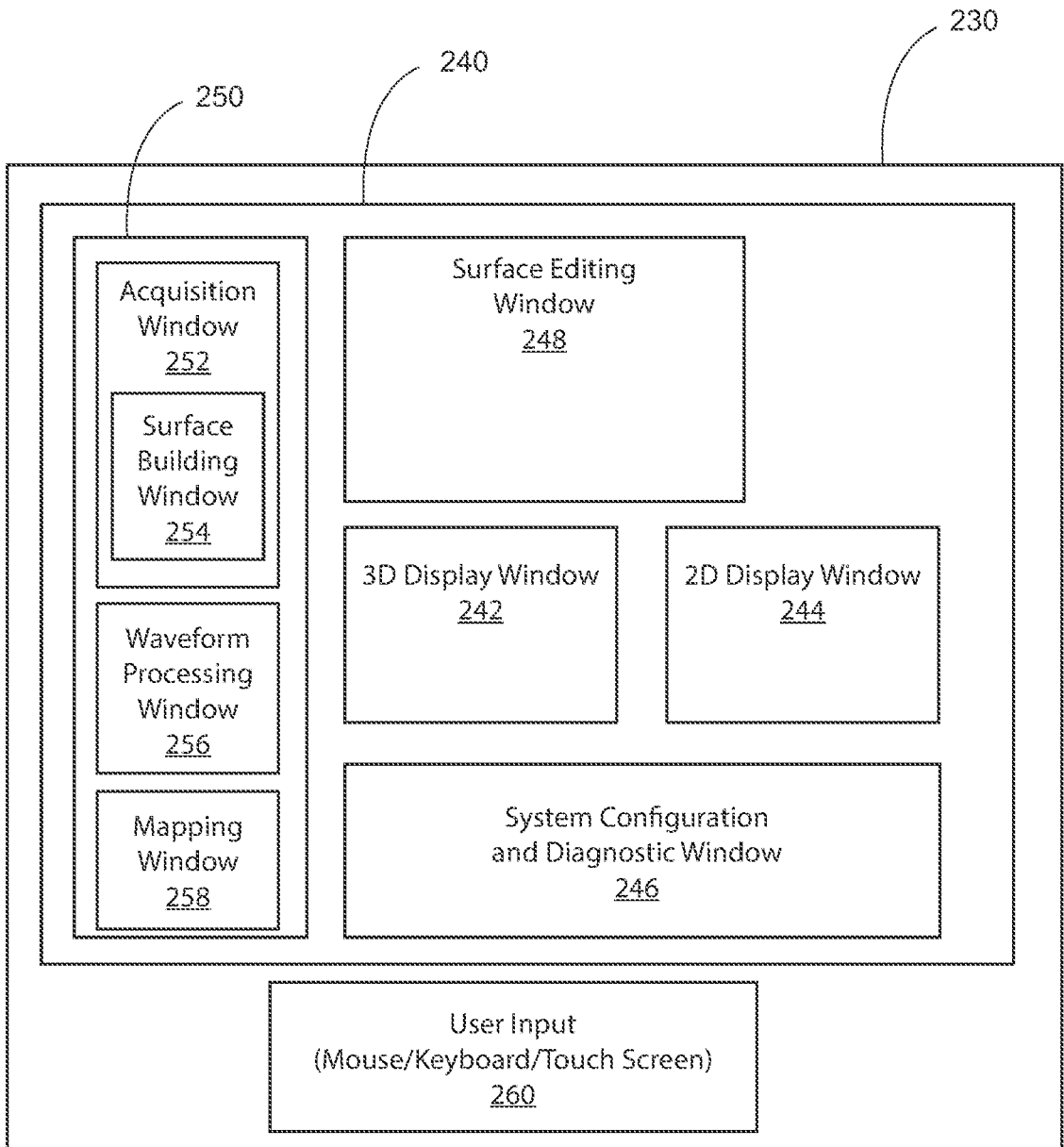

FIG 7

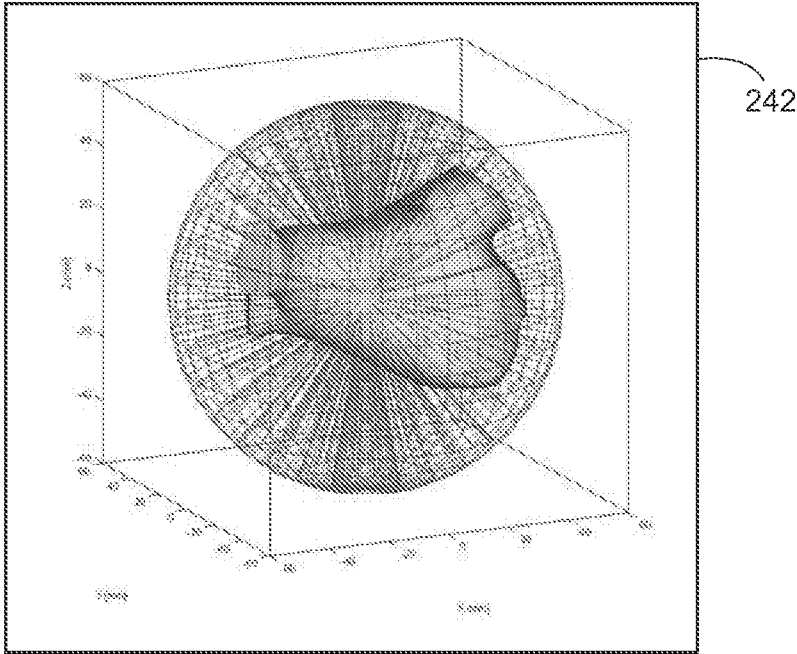

FIG 8A

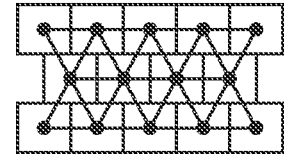

FIG 8C

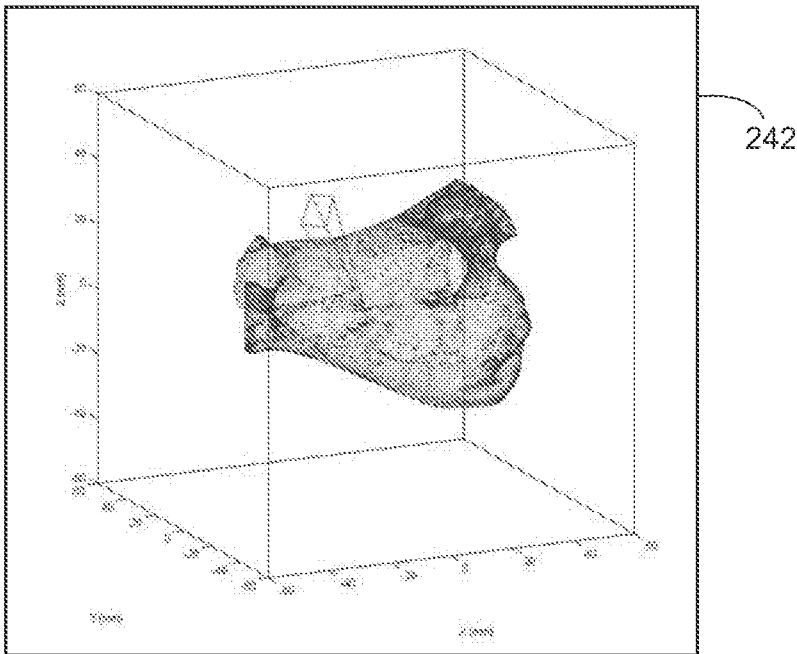

FIG 8B

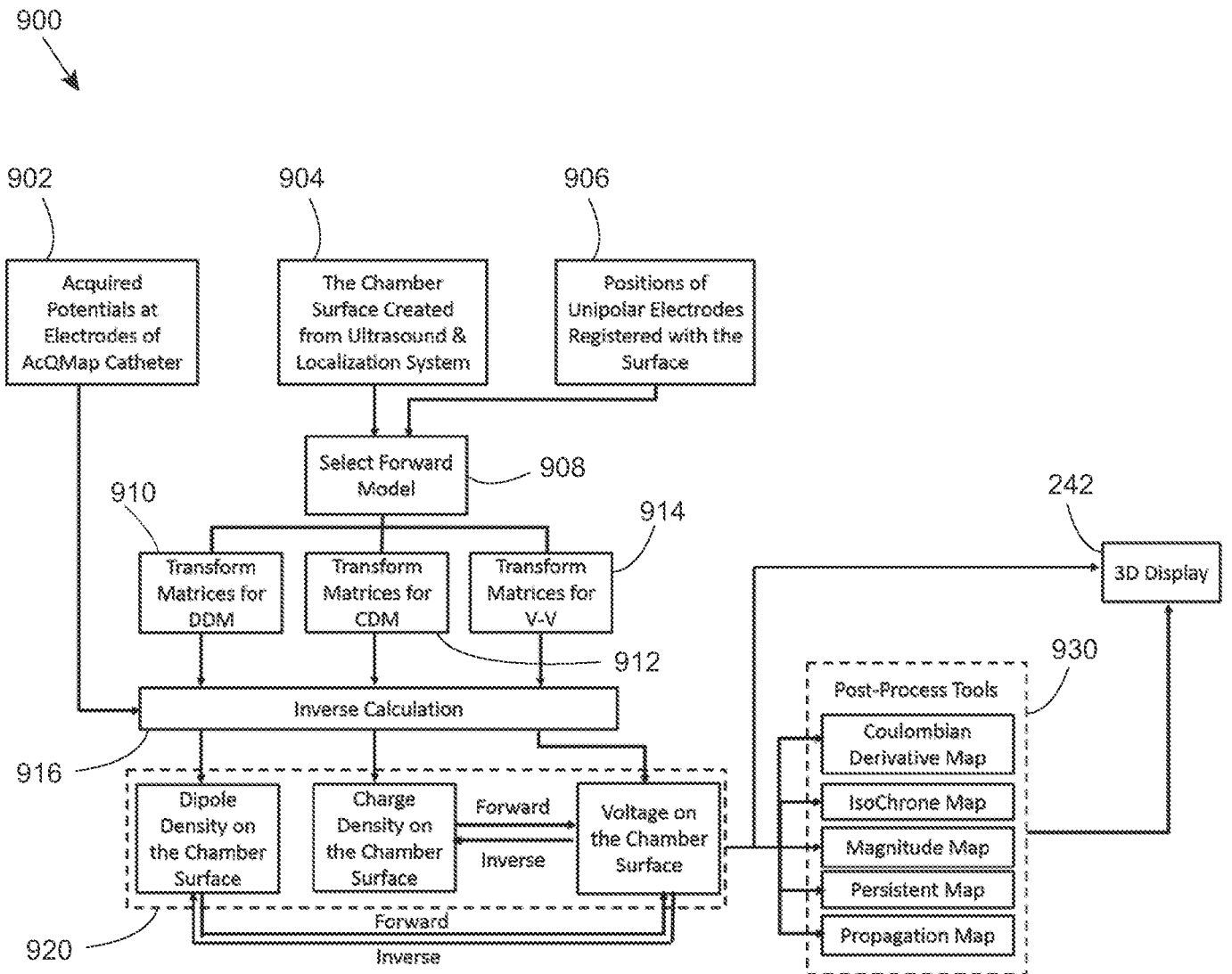

FIG 9

INTERNATIONAL SEARCH REPORT

International application No.

PCT/US2016/032017

<p>A. CLASSIFICATION OF SUBJECT MATTER IPC(8) - A61B 5/04; A61B 5/042; A61B 8/00; A61B 8/08; A61B 8/12; A61B 19/00 (2016.01) CPC - A61B 5/0422; A61B 5/06; A61B 8/12; A61B 8/445; A61B 18/1492; A61B 34/20 (2016.05) According to International Patent Classification (IPC) or to both national classification and IPC</p>														
<p>B. FIELDS SEARCHED</p> <p>Minimum documentation searched (classification system followed by classification symbols) IPC - A61B 5/04; A61B 5/042; A61B 8/00; A61B 8/08; A61B 8/12; A61B 19/00 CPC - A61B 5/0422; A61B 5/06; A61B 8/12; A61B 8/445; A61B 18/1492; A61B 34/20; A61B 2018/00839; A61B 2034/2051</p> <p>Documentation searched other than minimum documentation to the extent that such documents are included in the fields searched USPC - 600/301; 600/374; 600/424; 600/437; 600/443 (keyword delimited)</p> <p>Electronic data base consulted during the international search (name of data base and, where practicable, search terms used) Patbase, Google Patents, Google Scholar Search terms used: cardiac probe ultrasound electrophysiology transducers electrodes electrical potential coordinate system localization field</p>														
<p>C. DOCUMENTS CONSIDERED TO BE RELEVANT</p> <table border="1"> <thead> <tr> <th>Category*</th> <th>Citation of document, with indication, where appropriate, of the relevant passages</th> <th>Relevant to claim No.</th> </tr> </thead> <tbody> <tr> <td>X</td> <td>US 2013/0225983 A1 (BOSTON SCIENTIFIC SCIMED INC) 29 August 2013 (29.08.2013) entire document</td> <td>1-3, 31, 53, 73-78</td> </tr> <tr> <td>X</td> <td>US 2007/0060832 A1 (LEVIN) 15 March 2007 (15.03.2007) entire document</td> <td>39</td> </tr> <tr> <td>A</td> <td>US 2012/0165667 A1 (ALTMANN et al) 28 June 2012 (28.06.2012) entire document</td> <td>1-3, 31, 39, 53, 73-78</td> </tr> </tbody> </table>			Category*	Citation of document, with indication, where appropriate, of the relevant passages	Relevant to claim No.	X	US 2013/0225983 A1 (BOSTON SCIENTIFIC SCIMED INC) 29 August 2013 (29.08.2013) entire document	1-3, 31, 53, 73-78	X	US 2007/0060832 A1 (LEVIN) 15 March 2007 (15.03.2007) entire document	39	A	US 2012/0165667 A1 (ALTMANN et al) 28 June 2012 (28.06.2012) entire document	1-3, 31, 39, 53, 73-78
Category*	Citation of document, with indication, where appropriate, of the relevant passages	Relevant to claim No.												
X	US 2013/0225983 A1 (BOSTON SCIENTIFIC SCIMED INC) 29 August 2013 (29.08.2013) entire document	1-3, 31, 53, 73-78												
X	US 2007/0060832 A1 (LEVIN) 15 March 2007 (15.03.2007) entire document	39												
A	US 2012/0165667 A1 (ALTMANN et al) 28 June 2012 (28.06.2012) entire document	1-3, 31, 39, 53, 73-78												
<p><input type="checkbox"/> Further documents are listed in the continuation of Box C. <input type="checkbox"/> See patent family annex.</p>														
<p>* Special categories of cited documents:</p> <table border="0"> <tr> <td>"A" document defining the general state of the art which is not considered to be of particular relevance</td> <td>"T" later document published after the international filing date or priority date and not in conflict with the application but cited to understand the principle or theory underlying the invention</td> </tr> <tr> <td>"E" earlier application or patent but published on or after the international filing date</td> <td>"X" document of particular relevance; the claimed invention cannot be considered novel or cannot be considered to involve an inventive step when the document is taken alone</td> </tr> <tr> <td>"L" document which may throw doubts on priority claim(s) or which is cited to establish the publication date of another citation or other special reason (as specified)</td> <td>"Y" document of particular relevance; the claimed invention cannot be considered to involve an inventive step when the document is combined with one or more other such documents, such combination being obvious to a person skilled in the art</td> </tr> <tr> <td>"O" document referring to an oral disclosure, use, exhibition or other means</td> <td>"&" document member of the same patent family</td> </tr> <tr> <td>"P" document published prior to the international filing date but later than the priority date claimed</td> <td></td> </tr> </table>			"A" document defining the general state of the art which is not considered to be of particular relevance	"T" later document published after the international filing date or priority date and not in conflict with the application but cited to understand the principle or theory underlying the invention	"E" earlier application or patent but published on or after the international filing date	"X" document of particular relevance; the claimed invention cannot be considered novel or cannot be considered to involve an inventive step when the document is taken alone	"L" document which may throw doubts on priority claim(s) or which is cited to establish the publication date of another citation or other special reason (as specified)	"Y" document of particular relevance; the claimed invention cannot be considered to involve an inventive step when the document is combined with one or more other such documents, such combination being obvious to a person skilled in the art	"O" document referring to an oral disclosure, use, exhibition or other means	"&" document member of the same patent family	"P" document published prior to the international filing date but later than the priority date claimed			
"A" document defining the general state of the art which is not considered to be of particular relevance	"T" later document published after the international filing date or priority date and not in conflict with the application but cited to understand the principle or theory underlying the invention													
"E" earlier application or patent but published on or after the international filing date	"X" document of particular relevance; the claimed invention cannot be considered novel or cannot be considered to involve an inventive step when the document is taken alone													
"L" document which may throw doubts on priority claim(s) or which is cited to establish the publication date of another citation or other special reason (as specified)	"Y" document of particular relevance; the claimed invention cannot be considered to involve an inventive step when the document is combined with one or more other such documents, such combination being obvious to a person skilled in the art													
"O" document referring to an oral disclosure, use, exhibition or other means	"&" document member of the same patent family													
"P" document published prior to the international filing date but later than the priority date claimed														
<p>Date of the actual completion of the international search</p> <p>13 July 2016</p>		<p>Date of mailing of the international search report</p> <p>11 AUG 2016</p>												
<p>Name and mailing address of the ISA/ Mail Stop PCT, Attn: ISA/US, Commissioner for Patents P.O. Box 1450, Alexandria, VA 22313-1450 Facsimile No. 571-273-8300</p>		<p>Authorized officer Blaine R. Copenheaver</p> <p>PCT Helpdesk: 571-272-4300 PCT OSP: 571-272-7774</p>												

INTERNATIONAL SEARCH REPORT

International application No.

PCT/US2016/032017

Box No. II Observations where certain claims were found unsearchable (Continuation of item 2 of first sheet)

This international search report has not been established in respect of certain claims under Article 17(2)(a) for the following reasons:

1. Claims Nos.:
because they relate to subject matter not required to be searched by this Authority, namely:

2. Claims Nos.:
because they relate to parts of the international application that do not comply with the prescribed requirements to such an extent that no meaningful international search can be carried out, specifically:

3. Claims Nos.: 4-30, 32-38, 40-52, 54-72
because they are dependent claims and are not drafted in accordance with the second and third sentences of Rule 6.4(a).

Box No. III Observations where unity of invention is lacking (Continuation of item 3 of first sheet)

This International Searching Authority found multiple inventions in this international application, as follows:

1. As all required additional search fees were timely paid by the applicant, this international search report covers all searchable claims.
2. As all searchable claims could be searched without effort justifying additional fees, this Authority did not invite payment of additional fees.
3. As only some of the required additional search fees were timely paid by the applicant, this international search report covers only those claims for which fees were paid, specifically claims Nos.:

4. No required additional search fees were timely paid by the applicant. Consequently, this international search report is restricted to the invention first mentioned in the claims; it is covered by claims Nos.:

- Remark on Protest**
- The additional search fees were accompanied by the applicant's protest and, where applicable, the payment of a protest fee.
- The additional search fees were accompanied by the applicant's protest but the applicable protest fee was not paid within the time limit specified in the invitation.
- No protest accompanied the payment of additional search fees.

专利名称(译)	超声测序系统和方法		
公开(公告)号	EP3294122A4	公开(公告)日	2018-10-31
申请号	EP2016793503	申请日	2016-05-12
[标]申请(专利权)人(译)	阿库图森医疗有限公司		
申请(专利权)人(译)	ACUTUS MEDICAL INC.		
当前申请(专利权)人(译)	ACUTUS MEDICAL INC.		
[标]发明人	CHOU DERRICK R BEATTY GRAYDON E JULIAN MARCUS CORVI TIMOTHY J FLAHERTY J CHRISTOPHER FLAHERTY R MAXWELL		
发明人	CHOU, DERRICK R. BEATTY, GRAYDON E. JULIAN, MARCUS CORVI, TIMOTHY J. FLAHERTY, J. CHRISTOPHER FLAHERTY, R. MAXWELL		
IPC分类号	A61B5/04 A61B5/042 A61B8/00 A61B8/08 A61B8/12		
CPC分类号	A61B5/0422 A61B5/6853 A61B5/6858 A61B5/6859 A61B8/0883 A61B8/12 A61B8/445 A61B8/4494 A61B8/466 A61B8/483 A61B8/54 A61B1/04		
优先权	62/160529 2015-05-12 US		
其他公开文献	EP3294122A1		
外部链接	Espacenet		

摘要(译)

一种系统，包括导管，所述导管被配置用于递送到由周围组织限定的体腔；多个超声换能器，连接到导管的远端；电子模块，被配置为根据预定的激活顺序选择性地打开/关闭每个超声换能器，并处理从每个超声换能器接收的信号，以产生周围组织的至少2D显示。用户可以选择性地计算和显示心脏活动的各个方面。用户可以显示偶极密度（DDM），电荷密度（CDM）或电压（V-V）。可以显示腔室（表面）的形状和位置，以及记录在电极上的电位。系统还可以在不同的显示模式之间来回切换，并且使用后处理工具，可以改变各种类型的信息的显示方式。还提供了方法。