

(19) World Intellectual Property Organization
International Bureau



(43) International Publication Date
24 July 2003 (24.07.2003)

PCT

(10) International Publication Number
WO 03/059168 A1

- (51) International Patent Classification⁷: A61B 8/00, A61N 7/02
- (21) International Application Number: PCT/SE03/00045
- (22) International Filing Date: 15 January 2003 (15.01.2003)
- (25) Filing Language: English
- (26) Publication Language: English
- (30) Priority Data: 0200090-9 15 January 2002 (15.01.2002) SE
- (71) Applicant (for all designated States except US): ULTRA-ZONIX DNT AB [SE/SE]; Krossverksgatan 3, S-216 16 Malmö (SE).
- (81) Designated States (national): AE, AG, AL, AM, AT, AU, AZ, BA, BB, BG, BR, BY, BZ, CA, CH, CN, CO, CR, CU, CZ, DE, DK, DM, DZ, EC, EE, ES, FI, GB, GD, GE, GH, GM, HR, HU, ID, IL, IN, IS, JP, KE, KG, KP, KR, KZ, LC, LK, LR, LS, LT, LU, LV, MA, MD, MG, MK, MN, MW, MX, MZ, NO, NZ, OM, PH, PL, PT, RO, RU, SC, SD, SE, SG, SK, SL, TJ, TM, TN, TR, TT, TZ, UA, UG, US, UZ, VC, VN, YU, ZA, ZM, ZW.
- (84) Designated States (regional): ARIPO patent (GH, GM, KE, LS, MW, MZ, SD, SL, SZ, TZ, UG, ZM, ZW), Eurasian patent (AM, AZ, BY, KG, KZ, MD, RU, TJ, TM), European patent (AT, BE, BG, CH, CY, CZ, DE, DK, EE, ES, FI, FR, GB, GR, HU, IE, IT, LU, MC, NL, PT, SE, SI, SK, TR), OAPI patent (BF, BJ, CF, CG, CI, CM, GA, GN, GQ, GW, ML, MR, NE, SN, TD, TG).

- (72) Inventor; and
- (75) Inventor/Applicant (for US only): LIDGREN, Lars [SE/SE]; Örnvägen 35, S-227 31 Lund (SE).
- (74) Agents: ÅKERMAN, Mårten et al.; Albihns Malmö AB, P.O. Box 4289, S-203 14 Malmö (SE).

Declarations under Rule 4.17:

- as to applicant's entitlement to apply for and be granted a patent (Rule 4.17(ii)) for all designations
- of inventorship (Rule 4.17(iv)) for US only

Published:

- with international search report

[Continued on next page]

(54) Title: DEVICE FOR NON-INVASIVE ULTRASOUND TREATMENT OF AN OBJECT

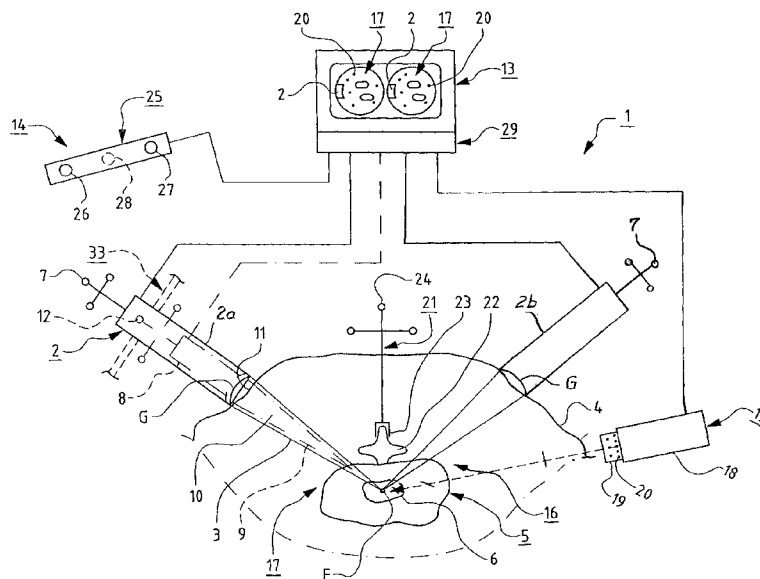

(57) Abstract: The present invention relates to a device for non-invasive ultrasound treatment of an object (5) of a patient, wherein at least two therapeutic ultrasound transducers (2a, 2b) are arranged for treatment of the object (5) by generating at least one ultrasonic field (3), the temperature focus (F) of which can be located in the object (5). A diagnostic ultrasound transducer (8) is arranged to determine the acoustic properties of the patient's (4) tissue (10) between the area on which the therapeutic ultrasound transducers (2a, 2b) are to be located during treatment and the object (5) in order to, in dependence of the acoustic properties determined by the diagnostic ultrasound transducer (8), set the therapeutic ultrasound transducers (2a, 2b) relative to the object (5).

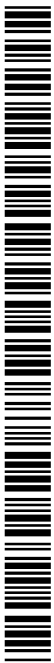

WO 03/059168 A1



For two-letter codes and other abbreviations, refer to the "Guidance Notes on Codes and Abbreviations" appearing at the beginning of each regular issue of the PCT Gazette.

DEVICE FOR NON-INVASIVE ULTRASOUND TREATMENT OF AN OBJECT

The present invention relates to a device for non-invasive ultrasound
5 treatment of an object of a patient, wherein at least one therapeutic ultrasound transducer is arranged for treatment of the object by generating at least one ultrasonic field, the temperature focus of which can be located in the object.

The intervertebral disc consists of an outer fibrous tissue ring, annulus fibrosus, and an inner, more viscous part, nucleus pulposus. The disc functions as a
10 shock absorber and if annulus fibrosus breaks, e.g. by a small fissuring, disc matter may find its way out and cause a compression of nerve roots and induce an inflammatory reaction.

Prolapsed intervertebral discs have been treated surgically since the thirties by removal of the displaced disc matter and/or a part of the bulging disc. Later, the
15 surgical treatment has developed towards less invasive operations and now, percutaneous techniques are used for removing disc matter. An alternative method for surgical treatment is chemonucleolysis, where the enzyme chymopapain is injected into nucleus pulposus, the central part of the disc. The enzyme polymerizes the long proteoglycan chains in nucleus pulposus with subsequent loss of the
20 hygroscopicity. This reduces the volume and pressure in nucleus pulposus and the bulging part of the disc, which explains the pain relief patients with sciatica experience after chemonucleolysis. The method has proven to give pain relief in 75 per cent of the cases and has a well documented cost efficiency. Unfortunately, the method has caused serious allergic reactions in about 1 per cent of the cases. Next
25 step in the development could be a non-invasive treatment of prolapsed intervertebral discs, which preferably should be painless, avoid the risk for infections and carried through ambulatory.

A method for thermotherapy and coagulation of tissue involves use of focused ultrasound with high intensity. The ultrasound passes well through soft
30 tissue and can be focused on remote spots within a surface of a few millimeters. The energy absorption in the tissue increases the temperature with a sharp temperature

gradient such that the boundaries of the treated volume are clearly limited without causing any damages on the surrounding tissue (US 5 291 890, US 5 501 655). Ultrasound treatment of prolapsed intervertebral discs is previously known (EP 0 872 262).

5 Heat treatment of discs has proven successful in a method called IDET (US 6 073 051, US 6 007 570, US 5 980 504). The method has as its aim to insert a catheter into the disc by means of a cannula. Farthest out on the catheter there is a coil which is heated by applying a radio frequency voltage thereon (US 5 785 705). The heat is increased to about 90°C in nucleus pulposus where the heating element
10 of the catheter has been located and treatment is carried through for 15 minutes.

Surgery with focused ultrasound has several advantages compared with other thermal techniques. Firstly, it can be non-invasive, secondly, the focus can be made movable and thirdly, the energy can be supplied during short time intervals. The limitation of ultrasound is its absorption in bone and its poor penetration through
15 gasfilled passages. Clinical applications of ultrasound surgery are today mostly used in ophthalmic surgery, urology and oncology. The effect of ultrasound can be divided into thermal and non-thermal effects.

The thermal effects of ultrasound are caused by absorption of ultrasound in the tissue. This leads to a temperature increase which is dependent on the
20 parameters of the ultrasound (frequency and intensity) and the acoustic properties of the tissue. The absorption of ultrasound in musculoskeletal tissues increases with the apatite and protein content, which means high absorption in bone, cartilage, tendons and ligaments. Water however, has a low ultrasound absorption capacity and can for this reason be used as an acoustic medium between the ultrasound
25 transducer and the tissue. Higher absorption can be expected in annulus fibrosus (high collagen content) than in nucleus pulposus (high water concentration). This will lead to higher temperatures in the outer part of the intervertebral disc than in the central part. In order to avoid that the temperature in annulus fibrosus exceeds a detrimental level at the same time as the temperature in nucleus pulposus reaches a
30 sufficient level, the ultrasound can be transmitted from several ultrasound sources. In this manner, the fields will overlap each other and increase the effect in nucleus

pulposus at the same time as the intensity in the surrounding tissue including annulus fibrosus can be kept low.

In devices for non-invasive ultrasound treatment of an object the ultrasonic field shall penetrate such parts of the patient's tissue between the area on which the therapeutic ultrasound transducer, which shall treat the object, is located and the object to be treated. Since the tissue structure in said parts of the patient's tissue and since the size of these tissue parts vary from patient to patient the power and/or the duration of the ultrasonic field have to be adapted thereto. Such an adaptation can be hard to accomplish.

An aim of the present invention has been to eliminate this problem and the problem has been solved by the before mentioned device comprising the characterizing features of the subsequent claim 1.

Due to the device comprising a diagnostic ultrasound transducer for determination of the acoustic properties of parts of the patient's tissue between the area in which the therapeutic ultrasound transducer is to be located for treatment and the object, one can easily adapt the ultrasonic field of the therapeutic ultrasound transducer to the tissue structure of said different patients and to the size of the tissue parts through which the ultrasonic field is to be directed.

The invention will be described in more detail with reference to the accompanying drawings, in which:

Fig. 1 schematically shows a constructive embodiment of the device according to the invention; and

Fig. 2 schematically shows a calibration device which can be comprised in a device according to Fig. 1.

The treatment device 1 schematically illustrated in fig. 1 is adapted to produce, by means of one or several therapeutic ultrasound emitting devices 2, one or several ultrasonic fields 3, the temperature focus F of which is intended to be located in the patient's object 5 for treatment thereof. According to one embodiment of the invention, the device 1 is adapted for treatment of the patient's intervertebral disc 5, preferably nucleus pulposus 6, and in the following description reference will be made to treatment of a patient's disc. However, it should be

understood that the invention is not limited to such treatment, but can be used in treatment of another object such as a ligament in a shoulder, knee, elbow or a foot, a blood vessel or a superficial object sensitive to ultrasound treatment.

The ultrasound emitting device 2 comprises at least one therapeutic
5 ultrasound transducer 2a and/or 2b for generating said ultrasonic field 3.

The ultrasound emitting device 2 can comprise a plurality of, preferably three or more, position emitters 7 for determination of its position.

The therapeutic ultrasound transducer 2a and/or 2b is more exactly adapted to achieve a local temperature increase in nucleus pulposus 6 so that enzymes such
10 as collagenase present in the disc 5 are activated and cause decomposition of collagen and proteoglycans, which results in shrinking of nucleus pulposus 6 mainly because of less hygroscopicity. The therapeutic ultrasound transducer 2a and/or 2b can for example emit its ultrasonic field 3 dorsolaterally from several different ports simultaneously. In order to be able to vary the focal distance of the
15 therapeutic ultrasound transducer 2a and/or 2b, i.e. the distance between its transmitter element G and the temperature focus F, said transmitter element G can be of the type phased array, which comprises several small piezoelectric elements. By excitation of these elements with different time delays a focussed ultrasonic field 3 is achieved.

20 However, the therapeutic ultrasound transducer can also be a single ultrasound transducer of a non-phased array type and having a focussing property. In the case of such an ultrasound transducer, the transmitter element can comprise a single piezoelectric element or be manufactured of several laminates or layers of piezoelectric elements. Further, the therapeutic ultrasound transducer of non-phased
25 array type can be used in the treatment of blood vessels or other superficial objects of the patient.

The treatment device 1 can also comprise a diagnostic ultrasound transducer 8. This is intended to achieve an ultrasonic field 9 for determination of the acoustic properties of the patient's 4 tissue 10 between the area 11 of the patient 4 on which
30 the therapeutic ultrasound transducer 2a and/or 2b is to be located during treatment and the disc 5, preferably nucleus pulposus 6, to be treated. This time of flight

measurement with the diagnostic ultrasound transducer 8 is performed in order to determine the distance between said area 11 and nucleus pulposus 6 and the thickness of the tissue and of the different tissue layers.

The tissue 10 that is penetrated consists in said order of skin, fat, muscle and
5 annulus fibrosus. This information is needed to correct for differences in different patients' size and tissue configuration since the attenuation is different in different kinds of tissue.

The diagnostic ultrasound transducer 8 can comprise a plurality of,
preferably three or more, position emitters 12 for determination of its position and it
10 is arranged to achieve an image of said tissue 10 in a monitor 13.

The treatment device 1 can also comprise an optical navigating device 14 for navigation of the therapeutic ultrasound transducer 2a and/or 2b (US 5 772 594). This optical navigating device 14 can comprise at least one diagnostic camera 15 which is intended to produce at least one image of the anatomical structure 17 of the
15 treatment area 16 in the monitor 13. The diagnostic camera can be an X-ray camera 18 taking two pictures of the anatomical structure 17 of the treatment area 16 from different directions with preferably a 90° intermediate angle and displaying these pictures in the monitor 13. At the optical navigating device 14, the X-ray camera 18 is used together with an optical analog-digital-converter for obtaining a real time
20 image in the monitor 13 of the position and direction of the therapeutic ultrasound transducer 2a and/or 2b (US 6 021 343, US 5 834 759, US 5 383 454).

The X-ray camera 18 can comprise a positioning device 19 – e.g. a cylindrical cover – which is located in front of the lens of the X-ray camera 18 and having markers 20 the mutual distances of which are known. The markers 20 can be
25 round and consist of metallic material e.g. tantalum.

In the optical navigating device 14, a reference device 21 can also be comprised, which reference device 21 is arranged to be attached to the spinous process 23 of a vertebra 22 or in a corresponding position such that it gets a determined position relative to the treatment area 16. The reference device 21 can
30 comprise several position transmitters 24, namely preferably at least three, and these can consist of metallic material e.g. tantalum.

Furthermore, the optical navigating device 14 can comprise a signal receiving and/or signal sending unit 25. This unit can comprise a suitable number of signal receivers 26, 27 for receiving signals from the therapeutic ultrasound transducer's 2a and/or 2b position transmitter 7, the diagnostic ultrasound transducer's 8 position transmitter 12 and the reference device's 28 position transmitter 24. The signal receiving and/or signal sending unit 25 can possibly comprise one or several signal transmitters 28 for transmitting signals to said position transmitters 7, 12 and 24, which are arranged to receive these signals.

The signals transmitted by the position transmitters 7, 12 and 24 can e.g. be in the form of infrared light or visible light or radio frequency electromagnetic waves or acoustic waves and the signal receivers 26, 27 can in such case be receivers of infrared light or visible light or radio frequency electromagnetic waves or acoustic waves.

The treatment device 1 can also comprise a computer 29 with at least one software arranged to calculate an appropriate setting of the therapeutic ultrasound transducer's 2a and/or 2b transmitter element G, in dependence of the acoustic properties determined by the diagnostic ultrasound transducer 8, such that the temperature focus F of the therapeutic ultrasound transducer's 2a and/or 2b ultrasonic field 3 can be obtained in the disc 5, preferably nucleus pulposus 6, to be treated.

Said software can alternatively, or in combination with said setting of the therapeutic ultrasound transducer 2a and/or 2b be arranged to calculate the position of the temperature focus F of the therapeutic ultrasound transducer's 2a and/or 2b ultrasonic field 3 in relation to the therapeutic ultrasound transducer 2a and/or 2b, in dependence of said acoustic properties and the therapeutic ultrasound transducer's 2a and/or 2b setting with regard to its focussing properties, such that the therapeutic ultrasound transducer 2a and/or 2b by means of the above mentioned optical navigation device 14 can be positioned such that said temperature focus F is obtained in the disc 5, preferably nucleus pulposus 6, to be treated.

The computer 29 can comprise a software arranged to calculate the power of the therapeutic ultrasound transducer's 2a and/or 2b ultrasonic field 3 in its

temperature focus F in dependence of the acoustic properties determined by the diagnostic ultrasound transducer 8, such that the temperature increase accomplished in nucleus pulposus 6 by the therapeutic ultrasound transducer 2a and/or 2b can be estimated.

5 In the treatment device 1 there can also be included a calibrating unit 30 for calibration of (a) the position of the therapeutic ultrasound transducer's 2a and/or 2b temperature focus F relative to its transmitter element G and (b) the therapeutic ultrasound transducer's 2a and/or 2b emitted heating power in said temperature focus F. The calibrating unit 30 has similar acoustic properties as human tissue and
10 contains a plurality of thermoelements 31 by means of which the position and the power of said temperature focus F can be measured for calibration. The thermoelements 31 are connected to a schematically illustrated measuring device 32.

Prior to treatment of the disc 5, preferably nucleus pulposus 6, the reference device 21 can be located on the patient's 4 vertebra 22 and the therapeutic
15 ultrasound transducer 2a and/or 2b and the diagnostic ultrasound transducer 8 can be calibrated in the calibrating unit 30. Thereafter a tissue analysis is performed by means of the diagnostic ultrasound transducer 8, which preferably is navigated by means of the optical navigation device 14 by its position transmitters 12 cooperating through signals with the signal transmitters 26, 27. On the monitor 13 a tissue image
20 can be produced which image is given by the diagnostic ultrasound transducer 8 and the thereby measured values of the tissue are used to adjust the focal distance and the power of the therapeutic ultrasound transducer 2a and/or 2b.

Two X-ray images of the patient's 4 anatomical structure 17 at the disc 5 is taken and these X-ray images are displayed on the monitor 13. On these X-ray
25 images, the position of the reference device's 21 position emitter 24 relative to the disc 5 can then be determined by means of the markers 20 of the positioning device 19.

During treatment of the disc 5, preferably nucleus pulposus 6, the therapeutic ultrasound transducer 2a and/or 2b is navigated by means of the signal receiving or
30 signal sending unit 25, whereby the navigation is presented in the X-ray images on the monitor 13. This is accomplished in that the position transmitters 7 of the

therapeutic ultrasound transducer 2a and/or 2b cooperate through signals with the signal transmitter 26 of the signal receiving or signal sending unit 25. By means of said navigation, the therapeutic ultrasound transducer 2a and/or 2b can be positioned such that the temperature focus F of its ultrasonic field 3 will fall in the disc 5, preferably nucleus pulposus 6. The temperature in the temperature focus F preferably exceeds 45°C.

The treatment can be automatically interrupted if the patient 4 moves to an incorrect position relative to the therapeutic ultrasound transducer 2a and/or 2b or vice versa.

10 The invention is not limited to the method described above, but can vary within the scope of the following claims.

Thus, the object 5 can be any disc in the body or another object of the patient. The diagnostic camera 15 can be a computerized tomography (CT) scanner which is arranged to produce images of said anatomical structure 17 and these images can be processed in a computer program or software for obtaining a 3D-15 image in the monitor 13. The diagnostic camera 15 can alternatively be an X-ray camera or a magnetic resonance imaging (MRI) camera, which is arranged to generate images of said anatomical structure 17 and these images can be processed in a computer program for obtaining a 3D-image in the monitor 13.

20 The therapeutic ultrasound transducer 2a and/or 2b can be arranged to be positioned manually or be arranged at a positioning device 33 for positioning the same relative to the disc 5 to be treated. The signal receiving and signal sending unit 25 of the optical navigation device 14 can be an X-ray device. The diagnostic ultrasound transducer 8 can comprise transmitter elements of phased array type to be able to vary the length or range of its ultrasound radiation.

If the ultrasound transmitter device 2 comprises at least two therapeutic ultrasound transducers 2a, 2b these can be locatable in different positions relative to each other and in such positions relative the disc 5, preferably nucleus pulposus 6, to be treated, that they together can generate the ultrasonic field 3 and its25 temperature focus F in said disc 5, preferably nucleus pulposus 6.

The therapeutic ultrasound transducers 2a, 2b can be controllable to together generate the ultrasonic field 3 with such an intensity that the tissue close to the disc 5, preferably nucleus pulposus 6, is not exposed to temperatures harmful for the tissue. They can also be controllable in order to be able to vary the distance between 5 themselves and the temperature focus F of the ultrasonic field 3.

The therapeutic and diagnostic ultrasound transducers 2a, 2b and 8 can be one and the same, they can be co-located or they can be arranged at several locations.

The described apparatus can be used in methods for treatment of discs but 10 also for treatment of other objects in the body. As an example of such other objects can be mentioned ligaments in for example shoulders, knees, elbows or feet, blood vessels, and other superficial objects.

Further, it should be understood that dependent on the object to be treated different steps and components described above can be excluded. The optical 15 navigation device and/or the reference device can for example be excluded in the case of treatment of ligaments since these structures often are superficial and having a site easy to determine.

CLAIMS

1. Device for non-invasive ultrasound treatment of an object, wherein at least two therapeutic ultrasound transducers (2a, 2b) are arranged for treatment of the object (5) by generating at least one ultrasonic field (3), the temperature focus (F) of which can be located in the object (5), and wherein a diagnostic ultrasound transducer (8) is arranged to determine the acoustic properties of the patient's (4) tissue (10) between the area on which said therapeutic ultrasound transducers (2a, 2b) are to be located for treatment and the object (5) to be treated to, in dependence of the acoustic properties determined by the diagnostic ultrasound transducer (8), adjust said therapeutic ultrasound transducers (2a, 2b) relative to the object (5) to be treated, **characterized in** that said therapeutic ultrasound transducers (2a, 2b) are locatable in different positions relative to each other and in such position relative to the object (5) to be treated that they together can generate the ultrasonic field (3) and its temperature focus (F) in said object (5), that said therapeutic ultrasound transducers (2a, 2b) are controllable for generating an ultrasonic field (3) with such intensity that tissue close to the object (5) is not exposed to tissue harmful temperatures, and that said therapeutic ultrasound transducers (2a, 2b) are controllable in order to be able to vary the distance between the same and the temperature focus (F) of the ultrasonic field (3).
2. Device according to claim 1, **characterized in** that the diagnostic ultrasound transducer (8) cooperates with a computer (29) comprising at least one software arranged to calculate appropriate setting of said therapeutic ultrasound transducers (2a, 2b) in dependence of the acoustic properties determined by the diagnostic ultrasound transducer (8), such that said temperature focus (F) can be brought to be achieved in the object (5) to be treated, whereby said software can alternatively or in combination with above mentioned setting of said therapeutic ultrasound transducers (2a, 2b) be arranged to calculate the position of the temperature focus (F) of said therapeutic ultrasound transducers (2a, 2b) in

dependence of said acoustic properties and said therapeutic ultrasound transducers (2a, 2b) setting with regard to its focussing properties, such that said therapeutic ultrasound transducers (2a, 2b) can be positioned such that said temperature focus (F) is achieved in the object (5) to be treated.

5

3. Device according to claim 2, **characterized in** that said computer (29) comprises at least one software arranged to calculate the heating effect of said therapeutic ultrasound transducer's (2a, 2b) ultrasonic field (3) in its temperature focus (F) in dependence of the acoustic properties determined by the diagnostic
10 ultrasound transducer (8).
4. Device according to any preceding claim, **characterized in** that the diagnostic ultrasound transducer (8) is arranged to determine the thickness of different tissue layer of said tissue (10) in order to determine the acoustic properties
15 thereof.
5. Device according to any preceding claim, **characterized in** that the diagnostic ultrasound transducer (8) is arranged to produce an image of said tissue (10).
- 20 6. Device according to any preceding claim, **characterized in** that the diagnostic ultrasound transducer (8) comprises transmitter elements of phased array type in order to vary the length of its ultrasound radiation.
7. Device according to any preceding claim, **characterized in** that said therapeutic
25 ultrasound transducer (2a, 2b) cooperates with an optical navigating device (14) comprising at least one diagnostic camera (15) adapted to produce at least one image of the anatomic structure (17) of the treatment area (16) within which the object (5) to be treated is located and in that the optical navigation device (14) further comprises at least one signal receiving or signal sending unit (25)
30 adapted to receive signals from or send signals to position transmitters (24, 7) on
a) a reference device (21) which has a fixed position relative to the object

(5), and

b) said therapeutic ultrasound transducer (2a, 2b) such that the position thereof relative to said treatment area (16) can be determined.

- 5 8. Device according to any preceding claim, **characterized in** that the diagnostic ultrasound transducer (8) comprises position transmitters (12) cooperating with the signal receiving or signal sending unit (25).
9. Device according to claim 7 or 8, **characterized in** that the signal receiving or
10 signal sending unit (25) is arranged to receive or send signals in the form of infrared light or visible light or radio frequency electromagnetic waves or acoustic waves and that said position transmitters (7, 24) are arranged to send or receive signals in the form of infrared light or visible light or radio frequency electromagnetic waves or acoustic waves.
- 15 10. Device according to claim 9, **characterized in** that the diagnostic camera (15) is an X-ray camera (18).
11. Device according to claim 10, **characterized in** that the X-ray camera (18)
20 comprises a positioning device (19) with markers (20) which are intended to determine the position of the anatomical structure (17) of the treatment area (16) displayed in a monitor (13).
12. Device according to claim 11, **characterized in** that the monitor (13) is arranged
25 to display two X-ray photographs of said anatomical structure (17) taken with the X-ray camera (18) from two different locations.
13. Device according to claim 7, **characterized in** that the diagnostic camera (15) is
30 a computerized tomography (CT) scanner which is arranged to produce images of the anatomical structure (17) at the patient's (4) object (5), which images are processed in a computer program (software) for obtaining a 3D-image in a

monitor (13).

14. Device according to claim 7, **characterized in** that the diagnostic camera (15) is a X-ray camera or a MRI scanner which is arranged to produce images of the anatomical structure (17) at the patient's (4) object (5), which images are processed in a computer program (software) for obtaining a 3D-image in a monitor (13).
15. Device according to any preceding claim, **characterized in** that the ultrasound transmitting device (2) comprises at least one therapeutic ultrasound transducer (2a, 2b) arranged to be positioned manually by means of calculated determination of the temperature focus (F) of said therapeutic ultrasound transducer's (2a, 2b) ultrasonic field (3) relative to said therapeutic ultrasound transducer's (2a, 2b) transmitter element (G).
16. Device according to any of claim 1 - 14, **characterized in** that the ultrasound transmitting device (2) comprises at least one therapeutic ultrasound transducer (2a, 2b) arranged at a positioning device (33) for positioning of the same relative the object (5) to be treated.
17. Device according to any preceding claim, **characterized in** that the ultrasound transmitting device (2) comprises at least one therapeutic ultrasound transducer (2a, 2b) comprising a transmitter element of phased array type in order to move the ultrasonic field (3) and its temperature focus (F).
18. Device according to any preceding claim, **characterized in** that the ultrasound transmitting device (2) is arranged to generate a temperature focus (F), the temperature of which exceeds 45°C.
19. Device according to any preceding claim, **characterized in** that a positioning device (19) is arranged for calibration of the power generated by said therapeutic

ultrasound transducer (2a, 2b) in the temperature focus (F) and/or the position of said temperature focus (F) relative to said therapeutic ultrasound transducer (2a, 2b).

- 5 20. Device according to claim 7, **characterized in** that the reference device (21) is arranged to be attached to a vertebra (22) in the patient's vertebral column, preferably to the spinal process (23) of said vertebra (22).
21. Device according to claim 7 or 20, **characterized in** that the reference device
10 (21) comprises position transmitters (24) consisting of metallic balls, preferably tantalum balls.
22. Device according to claim 21, **characterized in** that the signal receiving or
15 signal sending unit (25) of the optical navigating device (14) is at least one X-ray device.
23. Device according to any preceding claim, **characterized in** that said therapeutic and diagnostic ultrasound transducers (2a, 2b and 8) are co-located.
- 20 24. Device according to any of claims 1 - 22, **characterized in** that said therapeutic and diagnostic ultrasound transducers (2a, 2b and 8) are arranged at several locations.
- 25 25. Device according to any preceding claim, **characterized in** that the device is arranged for non-invasive ultrasound treatment of an object (5) in the form of nucleus pulposus (6) in the patient's (4) disc.
- 30 26. Device according to any preceding claim, **characterized in** that the device is arranged for non-invasive ultrasound treatment of an object (5) in the form of a ligament in a shoulder or a knee.

27. Use of a device according to any of the preceding claims, **characterized in** that it is used in methods for treatment of an object (5) in a patient's (4) body, such as for treatment of nucleus pulposus (6) in discs.
- 5 28. Use of a device according to any of claim 1 - 26, **characterized in** that it is used in methods for treatment of an object (5) in a patient's (4) body, such as ligaments in for example shoulders or knees.
- 10 29. Use of a device according to any of claim 1 - 26, **characterized in** that it is used in methods for treatment of an object (5) in a patient's (4) body, such as blood vessels.

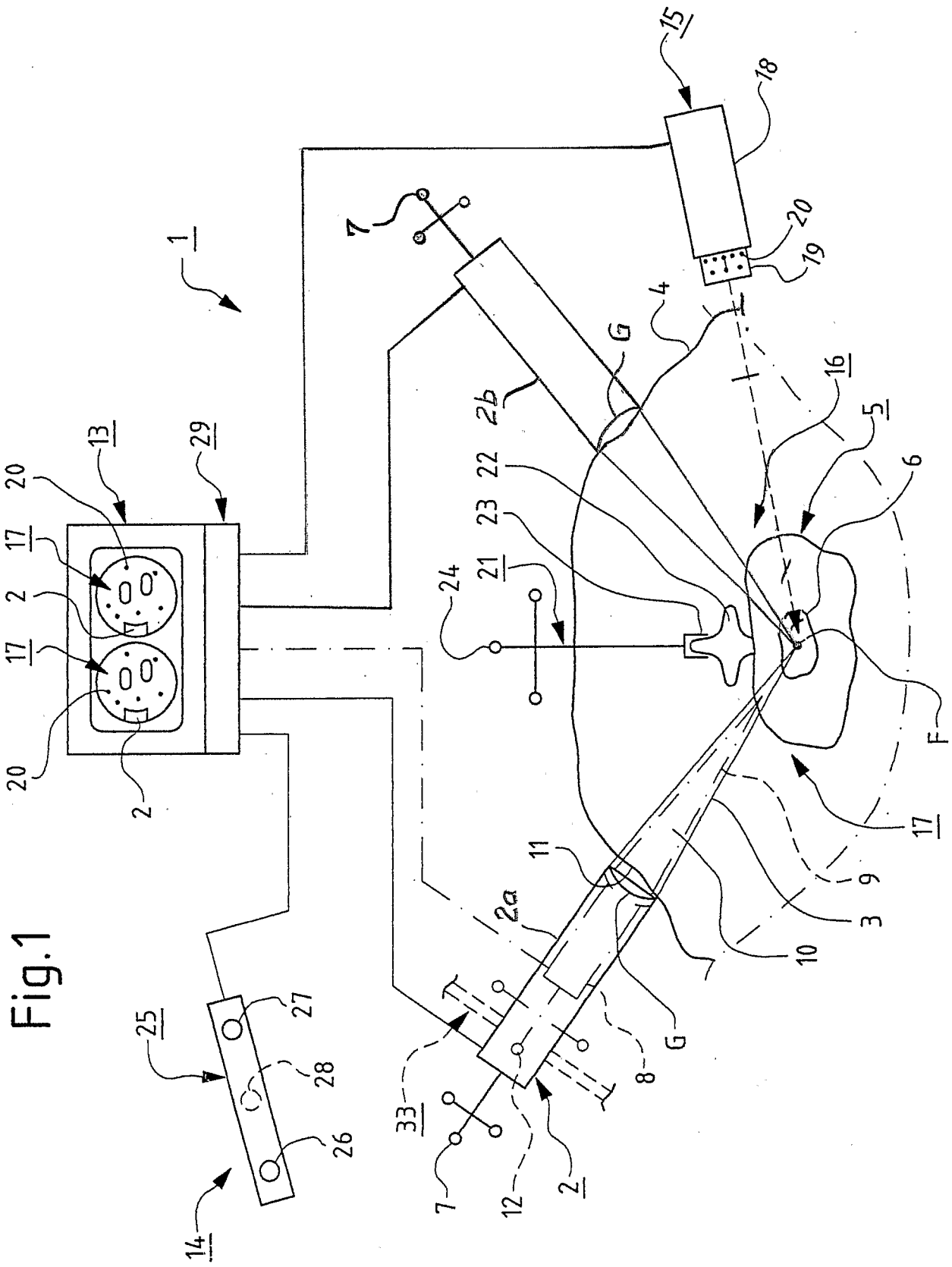
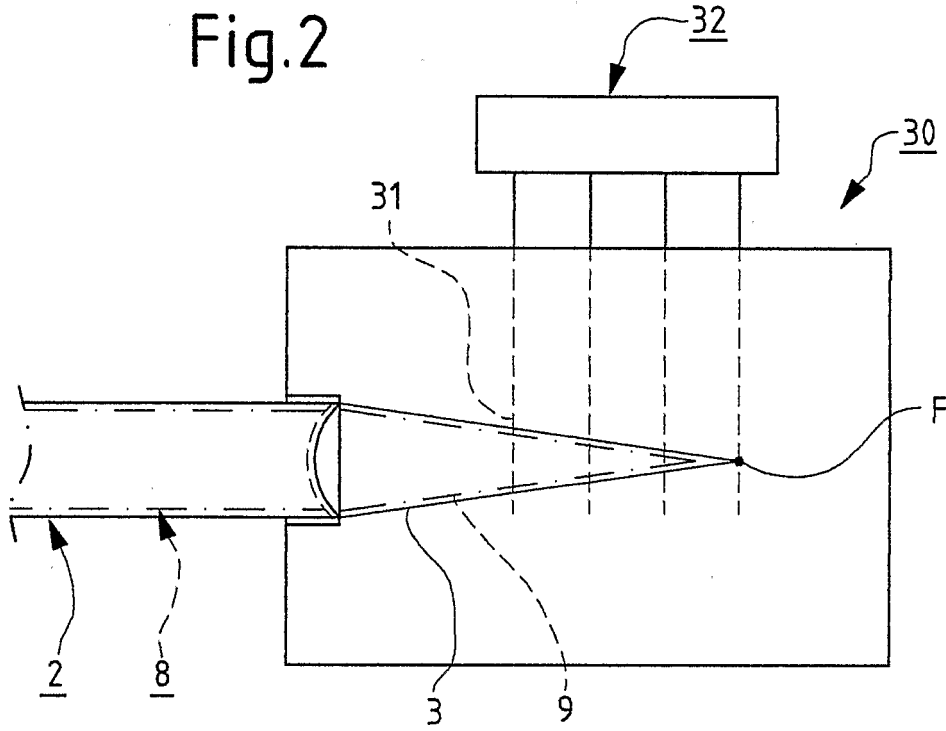

Fig.2



INTERNATIONAL SEARCH REPORT

International application No.
PCT/SE 03/00045

A. CLASSIFICATION OF SUBJECT MATTER

IPC7: A61B 8/00, A61N 7/02
According to International Patent Classification (IPC) or to both national classification and IPC

B. FIELDS SEARCHED

Minimum documentation searched (classification system followed by classification symbols)

IPC7: A61N, A61B

Documentation searched other than minimum documentation to the extent that such documents are included in the fields searched

SE,DK,FI,NO classes as above

Electronic data base consulted during the international search (name of data base and, where practicable, search terms used)

EPO-INTERNAL, WPI DATA, INSPEC

C. DOCUMENTS CONSIDERED TO BE RELEVANT

Category*	Citation of document, with indication, where appropriate, of the relevant passages	Relevant to claim No.
X	EP 0872262 A2 (SCANDIMED INTERNATIONAL AB), 21 October 1998 (21.10.98), column 4, line 19 - line 47; column 5, line 6 - line 17, figures 1,4 --	1-29
A	US 5769790 A (WATKINS, R.D. ET AL), 23 June 1998 (23.06.98), figure 3, abstract --	1-29
A	US 6267734 B1 (ISHIBASHI, Y. ET AL), 31 July 2001 (31.07.01), figure 1, abstract --	1-29

Further documents are listed in the continuation of Box C. See patent family annex.

* Special categories of cited documents:
 "A" document defining the general state of the art which is not considered to be of particular relevance
 "E" earlier application or patent but published on or after the international filing date
 "L" document which may throw doubts on priority claim(s) or which is cited to establish the publication date of another citation or other special reason (as specified)
 "O" document referring to an oral disclosure, use, exhibition or other means
 "P" document published prior to the international filing date but later than the priority date claimed
 "T" later document published after the international filing date or priority date and not in conflict with the application but cited to understand the principle or theory underlying the invention
 "X" document of particular relevance: the claimed invention cannot be considered novel or cannot be considered to involve an inventive step when the document is taken alone
 "Y" document of particular relevance: the claimed invention cannot be considered to involve an inventive step when the document is combined with one or more other such documents, such combination being obvious to a person skilled in the art
 "&" document member of the same patent family

Date of the actual completion of the international search: 14 April 2003
 Date of mailing of the international search report: 15-04-2003

Name and mailing address of the ISA/
 Swedish Patent Office
 Box 5055, S-102 42 STOCKHOLM
 Facsimile No. +46 8 666 02 86
 Authorized officer:
 Patrik Widerdal /OGU
 Telephone No. +46 8 782 25 00

INTERNATIONAL SEARCH REPORT

International application No.

PCT/SE 03/00045

C (Continuation). DOCUMENTS CONSIDERED TO BE RELEVANT		
Category*	Citation of document, with indication, where appropriate, of the relevant passages	Relevant to claim No.
P,A	WO 0205896 A1 (DIAGNOS NAVIGATION AND TREATMENT SCANDINAVIA AB), 24 January 2002 (24.01.02), the whole document ----- -----	1-29

INTERNATIONAL SEARCH REPORT

International application No.
PCT/SE 03/00045

Box I Observations where certain claims were found unsearchable (Continuation of item 1 of first sheet)

This international search report has not been established in respect of certain claims under Article 17(2)(a) for the following reasons:

1. Claims Nos.: 27-29
because they relate to subject matter not required to be searched by this Authority, namely:
see extra sheet

2. Claims Nos.:
because they relate to parts of the international application that do not comply with the prescribed requirements to such an extent that no meaningful international search can be carried out, specifically:

3. Claims Nos.:
because they are dependent claims and are not drafted in accordance with the second and third sentences of Rule 6.4(a).

Box II Observations where unity of invention is lacking (Continuation of item 2 of first sheet)

This International Searching Authority found multiple inventions in this international application, as follows:

1. As all required additional search fees were timely paid by the applicant, this international search report covers all searchable claims.
2. As all searchable claims could be searched without effort justifying an additional fee, this Authority did not invite payment of any additional fee.
3. As only some of the required additional search fees were timely paid by the applicant, this international search report covers only those claims for which fees were paid, specifically claims Nos.:

4. No required additional search fees were timely paid by the applicant. Consequently, this international search report is restricted to the invention first mentioned in the claims; it is covered by claims Nos.:

Remark on Protest

- The additional search fees were accompanied by the applicant's protest.
 No protest accompanied the payment of additional search fees.

INTERNATIONAL SEARCH REPORT

International application No.

PCT/SE 03/00045

Claims 27-29 relate to a method for treatment of the human body by therapy. Thus the International Search Authority is not required to carry out an international search for these claims (Rule 39.1 (iv)). Nevertheless, a search has been executed for claims 27-29.

INTERNATIONAL SEARCH REPORT

International application No.

PCT/SE 03/00045

Patent document cited in search report			Publication date	Patent family member(s)		Publication date
EP	0872262	A2	21/10/98	AU	724143 B	14/09/00
				AU	4140497 A	19/03/98
				BR	9711372 A	17/08/99
				EE	9900102 A	15/10/99
				EP	0978090 A	09/02/00
				JP	10295718 A	10/11/98
				JP	2000517081 T	19/12/00
				SE	518490 C	15/10/02
				SE	9701449 A	08/01/99
				US	6254553 B	03/07/01
US	5769790	A	23/06/98	NONE		
US	6267734	B1	31/07/01	EP	0734742 A	02/10/96
				JP	9103434 A	22/04/97
				US	5984881 A	16/11/99
				US	6086535 A	11/07/00
				US	6280402 B	28/08/01
				US	6334846 B	01/01/02
				US	6454713 B	24/09/02
WO	0205896	A1	24/01/02	AU	7120701 A	30/01/02
				NO	20030072 D	00/00/00
				SE	518763 C	19/11/02
				SE	0002677 A	18/01/02
				SE	0200003 A	18/01/02
				WO	02051642 A	04/07/02

专利名称(译)	用于对象的非侵入性超声治疗的装置		
公开(公告)号	EP1467656A1	公开(公告)日	2004-10-20
申请号	EP2003700658	申请日	2003-01-15
[标]申请(专利权)人(译)	乌尔特拉佐尼克斯DNT股份公司		
申请(专利权)人(译)	ULTRAZONIX DNT AB		
当前申请(专利权)人(译)	ULTRAZONIX DNT AB		
[标]发明人	LIDGREN LARS		
发明人	LIDGREN, LARS		
IPC分类号	A61B18/00 A61B8/00 A61B17/00 A61B19/00 A61N7/00 A61N7/02		
CPC分类号	A61N7/02 A61B34/20 A61B90/361 A61B2017/00261 A61B2017/00725 A61B2034/2055 A61B2034/2072 A61B2090/378 A61N2007/0078		
优先权	0200090 2002-01-15 SE		
外部链接	Espacenet		

摘要(译)

本发明涉及一种用于患者的对象(5)的非侵入式超声治疗的装置,其中至少两个治疗超声换能器(2a, 2b)被布置用于通过产生至少一个来治疗对象(5)超声场(3),其温度焦点(F)可以位于物体(5)中。设置诊断超声换能器(8)以确定在治疗期间治疗超声换能器(2a, 2b)将位于其上的区域与对象(5)之间的患者(4)组织(10)的声学特性。为了根据由诊断超声换能器(8)确定的声学特性,相对于物体(5)设置治疗超声换能器(2a, 2b)。