

(19)



(11)

**EP 3 125 769 B1**

(12)

**EUROPEAN PATENT SPECIFICATION**

(45) Date of publication and mention of the grant of the patent:  
**15.05.2019 Bulletin 2019/20**

(51) Int Cl.:  
**A61B 8/00 (2006.01)**

(21) Application number: **16761101.1**

(86) International application number:  
**PCT/CN2016/075919**

(22) Date of filing: **09.03.2016**

(87) International publication number:  
**WO 2016/141874 (15.09.2016 Gazette 2016/37)**

---

(54) **ULTRASOUND DIAGNOSTIC APPARATUS WITH EASY ASSEMBLY AND DISASSEMBLY**  
 ULTRASCHALLDIAGNOSEVORRICHTUNG MIT EINFACHER MONTAGE UND DEMONTAGE  
 APPAREIL DE DIAGNOSTIC À ULTRASONS PRÉSENTANT UN MONTAGE ET UN DÉMONTAGE FACILES

---

(84) Designated Contracting States:  
**AL AT BE BG CH CY CZ DE DK EE ES FI FR GB GR HR HU IE IS IT LI LT LU LV MC MK MT NL NO PL PT RO RS SE SI SK SM TR**

- **PENG, Chunlin**  
Wuxi  
Jiangsu 214028 (CN)
- **LU, Jian**  
Wuxi  
Jiangsu 214028 (CN)

(30) Priority: **10.03.2015 CN 201510105029**  
**30.09.2015 CN 201510640528**

(74) Representative: **Finnegan Europe LLP**  
**1 London Bridge**  
**London SE1 9BG (GB)**

(43) Date of publication of application:  
**08.02.2017 Bulletin 2017/06**

(73) Proprietor: **CHISON Medical Technologies Co., Ltd.**  
**Wuxi, Jiangsu 214142 (CN)**

(56) References cited:  
**WO-A2-2007/047457 CN-A- 101 438 965**  
**CN-A- 101 438 965 CN-A- 104 203 138**  
**CN-A- 104 306 020 CN-U- 202 283 259**  
**CN-U- 203 341 753 CN-Y- 201 119 884**  
**JP-A- 2012 197 074 US-A1- 2008 194 960**  
**US-A1- 2010 005 211 US-B1- 6 629 928**

(72) Inventors:  
• **SUN, Dongdong**  
Wuxi  
Jiangsu 214028 (CN)

**EP 3 125 769 B1**

Note: Within nine months of the publication of the mention of the grant of the European patent in the European Patent Bulletin, any person may give notice to the European Patent Office of opposition to that patent, in accordance with the Implementing Regulations. Notice of opposition shall not be deemed to have been filed until the opposition fee has been paid. (Art. 99(1) European Patent Convention).

**Description**Technical Field

**[0001]** The present disclosure relates to ultrasound diagnostic devices in general and, more particularly, to ultrasound diagnostic apparatus with easy disassembly and assembly, which improve performance and allow easy disassembly and assembly.

Background

**[0002]** Ultrasounds refer to sound waves with frequencies higher than the upper limit of human adult hearing, an average of which is approximately 20, 000 hertz. Ultrasounds have been used in various fields, including therapeutic and diagnostic fields. One popular diagnostic application is ultrasound imaging, which creates images of internal body structures, such as internal organs, vessels, bones and muscles, etc. When ultrasounds pulses are sent into tissues inside the body, due to the different acoustic impedances of the tissues, the ultrasounds will be reflected anywhere there are changes in the acoustic impedance. The return sound waves will be converted into electrical pulses and processed into a digital image for display. For example, obstetric/prenatal ultrasound is a widely used technique in pregnancy examination, which uses ultrasound waves to create visual images of the developing embryo or fetus in the mother's womb.

**[0003]** Conventional ultrasound diagnostic devices usually have a computer with a large sized case having different components installed therein. Those components are scattered inside the case and are connected by various cables. In the conventional ultrasound diagnostic devices, however, the scattered distribution and assembly of various components and connecting cables may interfere transmission of ultrasound and electrical pulses. In addition, the structural layout in the conventional ultrasound diagnostic devices may negatively affect heat dissipation, compromising overall device performance and imaging quality. Moreover, the above scattered layout makes it difficult and inconvenient for a technician to maintain, inspect, and repair components inside the computer case. For example, inspection and repair of certain components often requires disassembly of neighboring components, sometimes even the whole device. Furthermore, as some components are permanently secured onto an interior surface of the casing or manufactured as part of the casing, repair personnel often have to squat down to reach the components inside the casing.

**[0004]** CN 104306020 A relates to medical instruments, particularly to a portable B ultrasonic device.

**[0005]** Thus, there is a need to develop ultrasonic diagnostic systems and apparatus that reduce interferences in ultrasonic and electrical pulses, provide efficient heat dissipation, allow easy disassembly, assembly, and maintenance, and overcome the limitations of conven-

tional ultrasound diagnostic devices.

SUMMARY

**[0006]** The present disclosure includes an exemplary ultrasound diagnostic apparatus with easy assembly and disassembly. Embodiments of the apparatus comprise an outer casing, which includes a motherboard module having one or more motherboard guiding plugs and one or more motherboard ports installed thereon to facilitate the assembly, and a first outer-casing sliding device. Embodiments of the apparatus also comprise a main case structure being housed by the outer casing. The main case structure includes an I/O module, a power-supply module to receive a power supply and provide the power supply to the ultrasound diagnostic apparatus, a transducer panel module coupled to the I/O module and having a transceiver and a transducer information-processing module installed thereon, the transceiver being coupled to a transducer to emit and receive ultrasound electrical signals and the transducer information-processing module converting the received ultrasound electrical signals into digital information. The main case structure also includes a carrier board module coupled to the I/O module and to the transducer information-processing module via the I/O module and having a PC module installed thereon to process the converted digital information and transmit the processed digital information to an output device coupled to the one or more motherboard ports, the PC module being coupled to the motherboard module. It further includes one or more carrier-board guiding holes to receive the one or more motherboard guiding plugs and guide the assembly, one or more carrier-board ports to inter-plug in the one or more motherboard ports and facilitate data communications between the motherboard module and the carrier board module, and a first main-case sliding device to slide in the first outer-casing sliding device and facilitate the main case structure to move relative to the outer casing along the first outer-casing sliding device during the assembly and disassembly. In the embodiments of the apparatus, the motherboard module and the I/O module are installed on the main case structure's two opposite sides perpendicular to the transducer panel module and the carrier board module to allow the easy assembly and disassembly.

**[0007]** The invention is defined by the appended claims.

BRIEF DESCRIPTION OF THE DRAWINGS

**[0008]**

**FIG. 1** illustrates an exemplary ultrasound diagnostic apparatus consistent with the present disclosure.

**FIG. 2** illustrates a side view of an exemplary main case structure of the exemplary ultrasound diagnostic apparatus of **FIG. 1**.

**FIG. 3** illustrates a cutaway view of an exemplary

main case structure of **FIG. 2**.

**FIG. 4** illustrates another exemplary embodiment of a main case structure of the exemplary ultrasound diagnostic apparatus of **FIG. 1**.

**FIG. 5** illustrates a cutaway view of an exemplary outer casing of the exemplary ultrasound diagnostic apparatus of **FIG. 1**.

**FIG. 6** illustrates an exemplary assembly of the exemplary main case structure of **FIG. 2** with the exemplary outer casing of **FIG. 5**.

**FIG. 7** illustrates a rear view of an exemplary assembly of **FIG. 6**.

**FIG. 8** illustrates a side view of an exemplary structural connections among components of the exemplary main case structure of **FIG. 2** and those of the exemplary outer casing of **FIG. 5**.

**FIGS. 9A, 9B, and 9C** illustrate part of an exemplary power module of an exemplary main case structure of **FIG. 2**.

**FIGS. 10A, 10B, and 10C** illustrate exemplary sliding mechanisms between the exemplary main case structure of **FIG. 2** and the exemplary outer casing of **FIG. 5**.

#### DETAILED DESCRIPTION

**[0009]** Reference will now be made in detail to the exemplary embodiments illustrated in the accompanying drawings. Wherever possible, the same reference numbers will be used throughout the drawings to refer to the same or like parts.

**[0010]** Apparatus disclosed herein address the above described needs. For example, exemplary embodiments include a main case structure and an outer casing housing the main case, wherein through one or more mechanisms, such as sliding wheels, ball rollers, sliding bars, sliding slots, etc., the main case structure may move relative to the outer casing, and may further be detached from the outer casing when needed. For an accurate and secure connection during normal operation, the outer casing may include one or more positioning pins to be fitted into corresponding positioning holes on the main case structure. Alternatively, the main case structure may include one or more positioning pins to be fitted into corresponding positioning holes on the outer casing. As a result, the main case structure, along with the structural components installed inside, may be easily displaced and exposed for repair or maintenance. The outer casing may include a mother board containing a plurality of ports for connecting with a user display, an input device, a printer, and other devices. Some embodiments may include one or more insulation walls, one end of which may be secured onto an interior surface of the main case structure, to separate a transducer module and a processing module from each other. The insulation walls may be made of materials or coated with materials capable of reducing or substantially eliminating signal interference, such as zinc-coated metal sheets. As a result of signal interfer-

ence prevention, the diagnosis accuracy and overall device performance may be improved. Still other embodiments may include a battery insulation wall, to further prevent signal interference from the batteries. A battery installing panel on which the battery is installed may be connected to the main case structure, facilitating easy removal and inspection.

**[0011]** **FIG. 1** illustrates an exemplary ultrasound diagnostic apparatus consistent with the present disclosure. The exemplary ultrasound diagnostic apparatus 100, as shown in **FIG. 1**, includes a main case structure 110, an outer casing 120, an output device 130, an input device 140, a transducer array 150, and apparatus wheels 160. Main case structure 110 is housed inside outer casing 120. Output device 130 and input device 140 are connected to some ports on outer casing 120. In some embodiments, output device 130 and input device 140 may be housed in one device. In some embodiments, apparatus 100 may include more than one output device 130 and input device 140.

**[0012]** In some embodiments, output device 130 is a display device, such as a computer monitor, a laptop, a desktop, a touch screen, a smart phone, a TV set, a projector, or any of other display devices. In some embodiments, output device 130 may be a printer, a fax machine, image processing equipment, an email device, or any of other output devices to output ultrasound analytical data. In some embodiments, apparatus 100 may include more than one output device 130. Output device 130 may present to the user various data relating to the performance and operation of the apparatus, such as record of the patient, information about the patient's organs undergoing ultrasonic diagnosis, information about operation modes, videos or pictures obtained from the ultrasonic diagnosis, and environment condition information such as temperature and humidity.

**[0013]** Input device 140 could be a keyboard, a touch panel, a tablet, a laptop, a desktop, or other input devices. Through input device 140, a user may input apparatus control parameters and operation instructions, such as parameters relating to transmission of ultrasound pulses (frequency, timing, angle, etc.), and parameters controlling operation conditions of the apparatus or output display.

**[0014]** Transducer array 150 may include one or more transducers. Transducers may convert electrical signals to ultrasound pulses, and vice versa. Transducer array 150 may include transducers of different shapes, sizes, or models. The transducers may use different frequencies, and contain various numbers of elements.

**[0015]** Apparatus wheels 160 support apparatus 100 on a movable horizontal platform. Embodiments of the present disclosure may also be used in other types of ultrasound diagnostic apparatus such as those placed on a fixed platform, or affiliated to a larger piece of medical equipment.

**[0016]** **FIG. 2** illustrates an exemplary side view of main case structure 110 of the exemplary ultrasound diagnos-

tic apparatus of **FIG. 1**. As shown in **FIG. 2**, main case structure 110 includes a transducer module 210, a processor module 220, and a power module 230, each illustrated in a dashed box, respectively. In some embodiments, main case structure 110 may also include a transducer insulation wall 218.

**[0017]** In some embodiments, transducer module 210 may include one or more transducer ports 212, one or more transducer panels 214 having transducer ports 212 and one or more transceivers (not shown in **FIG. 2**) install thereon, and a transducer-panel baseboard 216 for installing the transducer panels 214. Transducer ports 212 may be coupled to transducers in array 150 of **FIG. 1**. Corresponding to the number and sizes of transducer ports 212 and transducers in array 150, main case structure 110 may further include one or more transducer windows (now shown in **FIG. 2**) through which the transducers in array 150 are connected to the transducer ports. Transducer panels 214 have one or more transducer ports 212, transceivers, and an information-processing module installed thereon. The transceivers can transmit or receive ultrasound electrical signals to or from an object under diagnosis. The information-processing module can convert the ultrasound electrical signals into digital information. Transducer-panel baseboard 216 is used to install transducer panels 214. Transducer-panel baseboard 216 may be permanently secured to or detachable from an interior surface of main case structure 110. Transducer-panel baseboard 216 may contain one or more materials capable of reducing or eliminating signal interference, such as zinc-coated metal sheets.

**[0018]** Transducer-panel baseboard 216 is installed on transducer insulation wall 218. Transducer insulation wall 214 is mounted onto an interior surface of main case structure 110 at one end portion or at both ends of structure 110, separating transducer module 210 and processor module 220 from each other and creating two relatively closed spaces. Transducer insulation wall 218 may contain one or more materials capable of eliminating or reducing signal interference between transducer module 210 and processor module 220, and interference from other components as well. For example, transducer insulation wall 218 may be made of zinc-coated metal sheets. Transducer insulation wall 218 may substantially surround transducer module 210, or alternatively substantially surround processor module 220, to improve signal interference prevention. In some embodiments, transducer insulation wall 218 divides an internal space of main case structure 110 into two relatively closed spaces vertically or horizontally, one closed space with transducer module 210 installed therein, and the other closed space with processor module 220 and power module 230 installed therein. In some embodiments, transducer insulation wall 218 may be of different designs and shapes, and may divide the internal space of main case structure 110 into spaces with different shapes and orientations.

**[0019]** In some embodiments, transducer module 210 may include one or more transducer fans 219, for heat

dissipation purpose. In some embodiment, as shown in **Fig. 2**, transducer fans 219 are installed in a bottom section of main case structure 110. Corresponding to a position of transducers fans 219, one or more ventilation openings may be configured on the casing of main case structure 110. The size and design of the ventilation openings may vary, depending on the working environment conditions, and an overall design of the apparatus.

**[0020]** With reference to **FIG. 2**, in some embodiments, processor module 220 may include a carrier board module 222, a PC module 224 installed on module 222, a PC fan 226 installed on module 224, and a carrier-board baseboard 228 for installing module 222. In some embodiments, processor module 220 may include one or more carrier-board fans 229. In some embodiments, carrier-board fans 229 are located near a bottom of main case structure 110.

**[0021]** Processor module 220 is configured to process and store data and information including ultrasound signals, parameter information, and patient information. Module 220 may also generate ultrasonic image and video/audio signals for display to the user, and store and perform user instructions such as apparatus control parameters. Processor module 220 may include any elements that control and coordinate the operation of other parts of the ultrasound diagnostic apparatus 100, for example, a central processing unit (CPU), a microprocessor, a graphics processing unit (GPU), an application specific integrated circuit (ASIC), a field-programmable gate array (FPGA), a complex programmable logic device (CPLD), a printed circuit board (PCB), a digital signal processor (DSP), a memory, etc.

**[0022]** In processor module 220 as shown in **FIG. 2**, PC module 224 may have a PC fan 226 installed thereon for dissipating heat generated by components of PC module 224. In some embodiments, PC module 224 may include a memory or a hard drive for data storage, and a CPU or GPU for data processing and digital image generation. Carrier-board baseboard 228 is used to install carrier board module 222, which has PC module 224 and other components installed thereon. Baseboard 228 may include one or more materials capable of reducing or eliminating signal interference, such as zinc-coated metal sheets.

**[0023]** In some embodiments, processor module 220 may include one or more carrier-board fans 229 for dissipating heat generated from components installed on carrier board module 222. In some embodiments, as shown in **FIG. 2**, carrier-board fans 229 are located near a bottom of main case structure 110. Corresponding to the position of carrier-board fans 229, one or more ventilation openings may be configured on the casing of main case structure 110. The size and design of the ventilation openings may vary, depending on working environment conditions and an overall design of the apparatus.

**[0024]** Still referring to **FIG. 2**, in some embodiments, power module 230 may include an AC-DC (alternating current to direct current) converter 232, a power-supply

filter panel 234, and a power-supply adapter 236. AC-DC converter 232 includes an input power socket to receive a power supply in a form of an alternating current, and converts it to a direct current power supply. The converted direct current power supply is provided to power-supply adapter 236 for adapting to a voltage required by components installed in main case structure 110 and outer casing structure 120. In some embodiments, AC-DC converter 232 may also include an output power socket to provide a power supply in a form of an alternating current. **FIGS. 9A-9C** illustrate part of an exemplary power module 230 of an exemplary main case structure of **FIG. 2**. As illustrated in **FIGS. 9A-9C**, power-supply filter panel 234 may be installed on AC-DC converter 232 to insulate signal interference caused by converter 232. In some embodiments, Panel 234 and converter 232 may form a functioning module, which is placed in a relatively closed insulation box 900, as shown in **FIG. 9B**. The insulation box can further eliminate or minimize signal interference on other components installed in main case structure 110. In some embodiments, the insulation box is not completely sealed, but with some openings for heat dissipation.

**[0025]** Referring back to **FIG. 2**, in some embodiments, power module 230 may further include a battery 238, and a battery insulation wall 239. Battery 238 of power module 230 may be installed in a close vicinity of a surface of main case structure 110. For example, as shown in **FIG. 2**, battery 238 is installed in a top section of main case structure 110, with one side parallel to the top surface of main case structure 110. Battery 238 may be installed on an installing panel that is attached to an interior surface of main case structure 110. This may facilitate easy removal, assembly, and maintenance of the battery and its neighboring components.

**[0026]** Battery insulation wall 239 helps insulating or separating the battery from transducer module 210, processor module 220, and other components inside main case 200, and eliminating or reducing signal interference caused by the battery on other components. The battery insulation wall may contain one or more materials capable of eliminating or reducing signal interference, such as zinc-coated metal sheets, to further prevent signal interference.

**[0027]** In some embodiments, battery 238 may be installed on battery insulation wall 239, which may be in turn installed on carrier-board baseboard 228. One end of battery insulation wall 239 may be coupled to a top portion of main case structure 110. This configuration facilitates easy maintenance and replacement of the battery when a battery failure or malfunction occurs. It can also eliminate or reduce signal interference caused by the battery on other components.

**[0028]** With reference to **FIG. 2**, in some embodiments, main case structure 110 may further include one or more handles 240 mounted on its exterior surface, and a sliding means 250 located on its bottom surface, to facilitate easy assembly and disassembly. In some embodiments,

sliding means 250 may include one or more sliding bars 252 and sliding wheels 254. In some embodiments, sliding mechanisms 252 and 254 may be sliding bars, sliding slots, ball rollers, or any other sliding means.

**[0029]** **FIG. 3** illustrates a cutaway view of the closed space including processor module 220 in main case structure 110 of **FIG. 2**. As shown in **FIG. 3**, the closed space of main case structure 110 includes processor module 220 installed therein. For comparison, the right side of main case structure 110 in **FIG. 1** shows components (such as transducer ports coupled to transducer array 150) installed in the other closed space. As shown in **FIG. 3**, main case structure 110 may further include one or more handles 240, a PC fan 226, a hard drive 300, a Wi-Fi module 302, one or more main-case positioning pillars 304, one or more carrier-board guiding holes 306, one or more carrier-board ports 308, an adapter insulation wall 310, a power supply adapter 236 installed on transducer insulation wall 218, one or more carrier-board fans 229, one or more sliding mechanisms 252, an AC-DC converter 232, and an input/output (I/O) module 312.

**[0030]** With reference to **FIG. 3**, processor module 220 may include PC module 224 (not shown in **FIG. 3**), PC fan 226 installed on PC module 224, carrier board module 222, hard drive 300 and Wi-Fi module 302 installed on carrier board module 222, and one or more carrier-board fans 229. Wi-Fi module 302 may be configured to transmit and receive, through a Wi-Fi connection, information such as apparatus control parameters, patient information, video and audio signals. In some embodiments, Wi-Fi module 302 or its components (e.g., a Wi-Fi antenna) may be attached to an exterior surface of main case structure 110.

**[0031]** In some embodiments, main-case positioning pillars 304 are to be coupled to or received by corresponding positioning holes on outer casing 120 (not shown in **FIG. 3**). Carrier-board guiding holes 306 are to couple with or receive corresponding guiding plugs on outer casing 120 (not shown in **FIG. 3**). In addition, main case structure 110 may include one or more carrier-board ports 308 to couple with corresponding motherboard ports on outer casing 120 (not shown in **FIG. 3**). More details will be provided below.

**[0032]** In some embodiments, power supply adapter 236 is installed on transducer insulation wall 218, and is further covered by an adapter insulation wall 310. Transducer insulation wall 218 and adapter insulation wall 310 form a relatively closed space, insulating power supply adapter 236 from causing signal interference on other components installed in main case structure 110.

**[0033]** In some embodiments, one or more carrier-board fans 229 are installed below power supply adapter 236 to dissipate heat generated by components of processor module 220 and adapter 236. To further heat dissipation, one or more ventilation openings may be configured near a bottom and/or top portion of main case structure 110. The size and design of the ventilation

openings may vary, depending on working environment conditions and an overall design of the apparatus.

**[0034]** In some embodiments, as shown in **FIG. 3**, main case structure 110 may include one or more sliding mechanisms 252 (such as sliding bars, sliding slots, sliding wheels, or ball rollers) installed on an exterior bottom surface of main case structure 110. Sliding mechanisms 252 couples with corresponding sliding means (such as sliding slots, sliding bars, sliding wheels, or ball rollers) installed on an interior bottom surface of the outer casing, such that main case structure 110 can slide along the sliding means on the outer casing and move relative to the outer casing. In some embodiments, sliding mechanisms 252 may be installed on an exterior side or top surface of the main case structure 110, and the sliding means on the outer casing may be installed on an interior side or top surface of the outer casing. Any type of sliding mechanisms, such as sliding slots, sliding bars, sliding wheels, or ball rollers, may be used to achieve relative displacement between the main case structure and the outer casing.

**[0035]** In some embodiments, main case structure 110 may include one or more handles 240, with which a user may manually move or pull main case structure 110 into or out of the outer casing. Acting in concert with sliding means 252 on main case structure 110 and the sliding means on the outer casing, handles 240 can facilitate the placement or displacement of main case structure 110 easily. As an alternative to handles 240, in some embodiments, one or more screw-rod mechanisms may be installed between main case structure 110 and outer casing 120, to facilitate the assembly or disassembly of main case structure 110 with or out of outer casing 120. For example, one or more screw-rods are installed on outer casing 120, and main case structure 110 is coupled to one or more screw nuts on the screw-rods. When the screw-rods is rotated, the screw nuts move along the screw-rods linearly, thereby moving main case structure 110 into or out of outer casing 120 along the screw-rods. The screw-rod mechanisms can also help align components on main case structure 110 with those on outer casing 120.

**[0036]** As explained previously, a power-supply filter panel may be installed on AC-DC converter 232. The filter panel and converter 232 form a functioning module, which is placed in a relatively closed insulation box, which can eliminate or minimize signal interference on other components installed in the main case structure 110. In addition, the insulation box is not completely sealed, but with some openings for heat dissipation.

**[0037]** I/O module 312 connects transducer module 210 to processor module 220, facilitates transmission of information and signals between transducer module 210 and processor module 220. In some embodiments, I/O module 312 may include various ports, such as one or more ports for HDMI, USB, VGA, or LAN connection, for transmission of data.

**[0038]** **FIG. 4** illustrates another exemplary embodi-

ment of main case structure 110 of the exemplary ultrasound diagnostic apparatus of **FIG. 1**. As shown in **FIG. 4**, main case structure 110 includes a hard drive port 402 on its top portion for receiving hard drive 300, and one or more hard drive screws 404 for securing hard drive 300 onto the top portion of main case structure 110. Comparing to the embodiment shown in **FIG. 3** in which hard drive 300 is installed on carrier board module 222, hard drive 300 in the embodiment shown in **FIG. 4** is secured onto a place close to an upper surface of main case structure 110. In some embodiments, hard drive 300 may be installed in another place close to a surface of the main case. This arrangement allows easy maintenance and removal of hard drive 300. When a technician maintains or replaces hard drive 300, the technician only needs to pull main case structure 110 out of outer casing 120, unscrew hard drive screws 404, and take hard drive 300 out from hard drive port 402. Further, in some embodiments, hard drive port 402 may be coupled to carrier board module 222 (not shown in **FIG. 4**), and hard drive 300 may be covered by a hard drive insulation wall to separate the hard drive from other components inside the main case structure, thus further preventing causing signal interference. The insulation wall may be made of materials or coated with materials capable of reducing or substantially eliminating signal interference, such as a zinc-coated metal sheet.

**[0039]** **FIG. 5** illustrates an exemplary embodiment of outer casing 120 of the exemplary ultrasound diagnostic apparatus of **FIG. 1**. As shown in **FIG. 5**, outer casing 120 may include one or more outer-casing positioning holes 502 to be coupled to or receive main-case positioning pillars 304 (as shown in **FIG. 3**), a motherboard module 510, one or more outer-casing ventilation openings 520, one or more sliding means 530 such as a sliding slot, and one or more transducer windows 540 corresponding to the transducer windows on the main case structure 110 (not shown in **FIG. 5**).

**[0040]** Motherboard module 510 may be manufactured as part of, or permanently secured onto or detachable from outer casing 120. In some embodiments, as shown in **FIG. 5**, motherboard module 510 is located on one side of outer casing 120. Motherboard module 510 may further include one or more ports for connecting with output device 130 and input device 140. In some embodiments, motherboard module 510 may include one or more motherboard guiding plugs 512 and one or more motherboard ports 514. During the process of placing/connecting main case structure 110 into/to outer casing 120, motherboard guiding plugs 512 contact and connect with carrier-board guiding holes 306 on main case structure 110 (as shown in **FIG. 3**) first, accurately aligning and connecting carrier-board ports 308 on main case structure 110 (as shown in **FIG. 3**) with motherboard ports 514. When a close connection between carrier-board ports 308 and motherboard ports 514 is almost completed, outer-casing positioning holes 502 touch and connect with main-case positioning pillars 304 (as shown in **FIG.**

3). As carrier-board ports 308 are closely connected with motherboard ports 514, main-case positioning pillars 304 are also closely fitted into outer-casing positioning holes 502, effectively affixing main case structure 110 and outer casing 120 together. Outer casing 120 can exchange information with output device 130 and input device 140 (as shown in FIG. 1) via motherboard module 510. Also, outer casing 120 can provide heat dissipation through its ventilation openings 520 and transducer window 540. Moreover, outer casing 120 can provide main case structure 110 with protection against dust.

**[0041]** With reference to FIG. 5, outer-casing ventilation openings 520 facilitate heat dissipation, and may be arranged near a bottom and/or top portion of outer casing 120. In some embodiments, outer-casing ventilation openings 520 may be configured at a location corresponding to that of ventilation openings on main case structure 110 (not shown in FIG. 5). The size and design of ventilation openings 520 may vary, depending on working environment conditions and an overall design of the apparatus.

**[0042]** Sliding means 530 work with sliding mechanisms 252 on main case structure 110 (shown in FIGS. 2 and 3) to facilitate a movement of main case structure 110 relative to outer casing 120 along a track, enabling an easy and accurate assembly of main case structure 110 with outer casing 120 and an easy disassembly of the two. For example, as illustrated in FIG. 10A, sliding mechanism 252 such as a sliding bar on main case structure 110 is coupled to and slides in sliding means 530 such as a sliding slot on outer casing 120, such that structure 110 and casing 120 can slide relative to each other to facilitate placement/displacement of structure 110 into/out casing 120. A sliding mechanism may be installed on a bottom, top, or side exterior surface of main case structure 110 and a corresponding sliding mechanism may be installed on a bottom, top, or side interior surface of outer casing 120, to facilitate relative movement between main case structure 110 and outer casing 120. In some embodiments, main case structure 110 and outer casing 120 may be assembled together by one or more fastening means, such as screws and hinges, and can be disconnected by unfastening the fastening means.

**[0043]** Referring to FIG. 5, when sliding mechanism 252 on main case structure 110 (not shown in FIG. 5) moves along sliding means 530 such as a sliding slot on outer casing 120, the main case structure moves relative to the outer casing for assembly or disassembly. The main case structure may be further pulled out of the outer casing when needed, for example, for purposes of maintenance or repair. Beside facilitating smooth movement of main case structure 110 within outer casing 120, sliding mechanism 252 and sliding means 530 can also help align carrier-board ports 308 on main case structure 110 (as shown in FIG. 3) with motherboard ports 514 on outer casing 120 on a same axis, facilitating an easy and accurate connection between them.

**[0044]** In some embodiments, sliding means 530 may

include one or more sliding stoppers 1002 at one of its end sections (as illustrated in FIG. 10B). Sliding stoppers 1002 can be elastic stopping devices (such as elastic flaps) or rigid stopping devices (such as rigid baffles). Sliding stoppers can restrict the sliding movement of main case structure 110 within a certain limit. For example, a sliding stopper may be installed at sliding means 530's end closer to motherboard module 510 (as shown in FIG. 5). The sliding stopper can control a distance of main case structure 110 traveling into outer casing 120, such that the movement of main case structure 110 may be hindered once it reaches the motherboard module. This arrangement can prevent carrier-board ports 308 on main case structure 110 (as shown in FIG. 3) from clashing with motherboard ports 514 on outer casing 120, avoiding damages to ports 208 and 514.

**[0045]** Sliding means 250 on main case structure 110 (shown in FIG. 2) and sliding means 530 on outer case 120 (shown in FIG. 5) can be any type of sliding mechanisms such as one or more sliding bars, sliding slots, sliding tracks, sliding wheels, or ball rollers, etc. For example, as illustrated in FIG. 10C, main case structure 110 includes one or more sliding wheels 254 to move relative to outer casing 120. In some embodiments, sliding wheels 254 facilitate sliding bar 252 to slide in sliding slot 530 smoothly. Sliding wheels 254 may be cylindrical, spherical, and any other shapes. Sliding wheels 254 may be installed on a top, bottom, or side exterior surface of the main case structure, to move along corresponding sliding tracks or slots on the outer casing. In some embodiments, sliding wheels 254 may move on an interior surface of outer casing 120. In some embodiments, a combination of different sliding means, for example, a combination of sliding bars, sliding slots, and sliding wheels, may be used, as illustrated in FIG. 2.

**[0046]** FIG. 6 illustrates an exemplary assembly of exemplary main case structure 110 of FIG. 2 with exemplary outer casing 120 of FIG. 5. As shown in FIG. 6, main case structure 110 includes carrier board module 222, one or more carrier-board guiding holes 306, one or more carrier-board ports 308, and one or more sliding bars 252 on its bottom exterior surface. Outer casing 120 includes motherboard module 510, and one or more sliding slots 530 on its bottom interior surface. Motherboard module 510 further includes one or more motherboard guiding plugs 512 and one or more motherboard ports 514. During assembly, main case structure 110 slides along a sliding track into (606) outer casing 120 via sliding bars 252 fitting into and sliding along sliding slots 530, carrier-board guiding holes 306 connecting with and receiving (602 and 604) motherboard guiding plugs 512, carrier-board ports 308 being accurately aligned with and interconnected with motherboard ports 514, and thus ensuring that carrier board module 222 accurately interconnects with motherboard module 510.

**[0047]** In some embodiments, motherboard module 510 and carrier board module 222 may be connected by other fastening means, for example, screws and fasten-

ing clamp, to secure the attachment. Outer casing 120 houses main case structure 110, preventing dust in the environment from landing on main case structure 110 and its components. In some embodiments, one or both of outer casing 120 and the casing of main case structure 110 may contain one or more materials capable of reducing or eliminating signal interference.

**[0048]** FIG. 7 illustrates a rear view of an exemplary assembly of FIG. 6. As shown in FIG. 7, after main case structure 110 is assembled with outer casing 120 to form an assembly, one or more fastening means 702 may be used to securely fasten main case structure 110 and outer casing 120 together. Various fastening means may be utilized, for example, screws and fastening clamps.

**[0049]** An I/O module 312 is installed onto a rear side of main case structure 110. As previously discussed, I/O module 312 facilitates transmission of information and signals between the transducer module (connected to transducer array 150) and the processor module. In some embodiments, I/O module 312 may include various ports, such as one or more ports for HDMI, USB, VGA, or LAN connection, for data transmission. Below I/O module 312, an AC-DC converter 232 and power-supply filter panel 234 (not shown in FIG. 7) are installed on main case structure 110. One or more fastening means 704 are installed beneath outer casing 120 for fastening the assembly to a moving platform, which may have one or more apparatus wheels 160 (as shown in FIG. 1).

**[0050]** FIG. 8 illustrates a side view of an exemplary structural connections among components of main case structure 110 of FIG. 2 and those of outer casing 120 of FIG. 5. As shown in FIG. 8, main case structure 110 includes one or more transducer panels 214, a battery 238, a PC module 224, a PC fan 226 installed on PC module 224, a hard drive 300, a carrier board module 222, a power-supply adapter 236, and an I/O module 312. I/O module 312 may further include one or more board-to-board connectors 802, one or more user interface ports 804, and one or more information ports 806. Components on main case structure 110 interconnect and communicate data with components on outer casing 120 via motherboard ports 514 on motherboard module 510. In some embodiments, information ports 806 may include one or more ultrasound signal ports, control-parameter signal ports, analog signal ports, digital signal ports, and power-supply signal ports, or any combination thereof, to transmit data and information.

**[0051]** To facilitate an easy separation or disassembly of main case structure 110 from outer casing 120, the separation or disassembly process does not need to unplug or plug wires connecting components of structure 110 with components of outer casing 120. As illustrated in FIG. 8, I/O module 312 connects transducer panels 214 to carrier board module 222. Transducer panels 214 connect with information ports 806 on I/O module 312 via various data wires or cables. And carrier board module 222 inter-plugs in and connects with I/O module 312 via board-to-board connectors 802. When a user needs

to read ultrasound diagnostic data, the user can do so by connecting an exterior read device to user interface ports 804 (such as ports for VGA, HDMI, USB, LAN, etc.) on I/O module 312. In some embodiments, I/O module 312 transmits data and signals among board-to-board connectors 802, user interface ports 804, and information ports 806, via data wires and cables connecting those ports.

**[0052]** Moreover, carrier board module 222 performs data transmission with motherboard ports 514 via inter-plug-in communications. In some embodiments, as illustrated in FIG. 8, I/O module 312 and motherboard module 510 are arranged and installed on the main case structure's two opposite sides perpendicular to transducer panels 214 and carrier board module 222. This arrangement allows data transmission through I/O module 312 and motherboard module 510 installed on two ends of the main case structure, further reducing signal interference. This arrangement can also facilitate easy and quick disassembly or separation of main case structure 110 from outer casing 120, by unplugging or detaching I/O module 312 and motherboard module 510 from their counterparts, without unplugging various wires and cables and without obstacles caused by various wires and cables.

**[0053]** By coupling carrier board module 222 to I/O module 312 installed on main case structure 110 and motherboard module 510 installed on outer casing 120, PC module 224 installed on carrier board module 222 can obtain from and transmit data to devices connected to I/O module 312 and motherboard module 510, such as output device 130, input device 140, and transducer array 150. For example, information ports 806 transmit information, such as ultrasound digital information, control-parameter information, electrical pulse information, etc., to carrier board module 222. Carrier board module 222 in turn transmits the information to PC module 224. In addition, motherboard module 510 transmits information (such as video or image information, parameter information, audio information, etc.), received via motherboard ports 514, to output device 130 for display or output. Furthermore, motherboard ports 514 transmit information (such as control-parameter information, input information, etc.), received from input device 140 and output device 130, to carrier board module 222, which transmits the received information to PC module 224.

**[0054]** During an operation of ultrasound diagnostic apparatus 100, a user controls a transducer in transducer array 150 to emit/receive ultrasound electrical signals to/from a patient's body, via transceivers on transducer panels 214. The transceivers transmit the ultrasound electrical signals to an information-processing module on transducer panels 214 for converting the ultrasound electrical signals into digital information. The information-processing module transmits the digital information to carrier board module 222, via information ports 806 on I/O module 312. Carrier board module 222 passes the received digital information to data-processing units

(such as CPU, GPU, memory, etc.) on PC module 224 for data processing. PC module 224 transmits the processed digital information to hard drive 300 for storage, and transmit the processed information (such as video/image information, parameter information, etc.) to output device 130 (such as a display) via motherboard ports 514 and motherboard module 510. The user obtains from output device 130 various needed information, such as image data information, video, detection parameters of the patient's various organs, environment parameters, apparatus parameters, etc. The user can control apparatus 100, input information on apparatus 100, or inquire information from apparatus 100 based on the user's experience and the information presented on output device 130. The user can achieve the above tasks by inputting various control parameters for apparatus 100 on input device 140. Input device 140 transmits the inputted control parameters to PC module 224 installed in main case structure 110, via various data cables, motherboard ports 514, and motherboard module 510. PC module 224 controls and reconfigures various modules and their components based on the received control parameters and/or pre-configured parameters. For example, PC module 224 can control and adjust one or more transmission parameters such as transmission frequencies, transmission time, and/or transmission angles of transducers in array 150, via the transceivers on transducer panels 214. PC module 224 can also perform data input and output via motherboard module 510 and motherboard ports 514.

**[0055]** In the preceding specification, the invention has been described with reference to specific exemplary embodiments. The specification and drawings are accordingly to be regarded as illustrative rather than restrictive. Other embodiments of the invention may be apparent to those skilled in the art from consideration of the specification and practice of the invention disclosed herein.

## Claims

1. An ultrasound diagnostic apparatus (100) with easy assembly and disassembly, comprising:

an outer casing (120) including:

a motherboard module (510) having one or more motherboard guiding plugs (512) and one or more motherboard ports (514) installed thereon to facilitate the assembly, and  
a first outer-casing sliding device (530); and

a main case structure (110) being housed by the outer casing (120), including:

an I/O module (312),  
a power-supply module (230) to receive a

power supply and provide the power supply to the ultrasound diagnostic apparatus (100),

a transducer panel module (210) coupled to the I/O module (312) and having a transceiver and a transducer information-processing module installed thereon, the transceiver being coupled to a transducer to emit and receive ultrasound electrical signals and the transducer information-processing module converting the received ultrasound electrical signals into digital information,

a carrier board module (222) coupled to the I/O module (312) and to the transducer information-processing module via the I/O module (312) and having a PC module (224) installed thereon to process the converted digital information and transmit the processed digital information to an output device (130) coupled to the one or more motherboard ports (514), the PC module being coupled to the motherboard module,

one or more carrier-board guiding holes (306) to receive the one or more motherboard guiding plugs (512) and guide the assembly,

one or more carrier-board ports (308) to inter-plug in the one or more motherboard ports (514) and facilitate data communications between the motherboard module and the carrier board module (222), and  
a first main-case sliding device (530) to slide in the first outer-casing sliding device and facilitate the main case structure to move relative to the outer casing along the first outer-casing sliding device during the assembly and disassembly;

wherein the motherboard module (510) and the I/O module (312) are installed on the main case structure's two opposite sides perpendicular to the transducer panel module (210) and the carrier board module (222) to allow the easy assembly and disassembly.

2. The ultrasound diagnostic apparatus according to claim 1, further comprising:

an input device (140) coupled to the one or more motherboard ports (514) to receive control parameters provided by a user,  
wherein the PC module (224) is coupled to the input device (140) via the motherboard module (510) and the one or more motherboard ports (514) to receive the inputted control parameters.

3. The ultrasound diagnostic apparatus according to

claim 2, wherein:

the PC module (224) controls the transducer by:

adjusting one or more transmission parameters relating to a transmission frequency, a transmission time, and/or a transmission angle based on the received control parameters, and transmitting the adjusted one or more transmission parameters to the transceiver via the I/O module (312).

4. The ultrasound diagnostic apparatus according to any of the preceding claims, wherein:

during the assembly, the main case structure (110) slides into the outer casing (120) along the first outer-casing sliding device to enable the one or more motherboard guiding plugs (512) to plug into the one or more carrier-board guiding holes (306) and enable the one or more carrier-board ports (308) to align with the one or more motherboard ports (514) for the inter-plugging in.

5. The ultrasound diagnostic apparatus according to claim 4, wherein:

the outer casing (120) further includes one or more outer-casing positioning holes (502); and the main case structure (110) further includes one or more main-case positioning pillars (304) to fit into the one or more outer-casing positioning holes (502) when the one or more carrier-board ports (308) inter-plug into the one or more motherboard ports (514), affixing the main case structure with the outer casing together.

6. The ultrasound diagnostic apparatus according to any of the preceding claims, wherein:

the first outer-casing sliding device (530) includes a sliding stopper (1002) to stop the first main-case sliding device and restrict the main case structure (110) to move inside the outer casing within a certain range, preferably wherein the sliding stopper (1002) is located near the first outer-casing sliding device's end close to the outer casing's side installing the motherboard module (510) having the one or more motherboard ports (514) to allow the inter-plugging in between the one or more carrier-board ports (308) and the one or more motherboard ports (514) on the main case structure (110) and prevent the one or more carrier-board ports (308) from clashing with the one or more motherboard ports.

7. The ultrasound diagnostic apparatus according to any of the preceding claims, wherein:

the main case structure (110) further includes a second main-case sliding device to slide on an interior surface of the outer casing and facilitate the first main-case sliding device to slide in the first outer-casing sliding device smoothly, preferably wherein the outer casing further includes a second outer-casing sliding device to allow the second main-case sliding device to slide therein.

8. The ultrasound diagnostic apparatus according to any of the preceding claims, wherein:

the outer casing (120) further includes one or more screw-rods installed between the outer casing (120) and the main case structure (110), the main case structure being coupled to one or more screw nuts on the screw-rods, and when the screw-rods is rotated, the one or more screw nuts move along the screw-rods linearly to move the main case structure (110) into or out of the outer casing (120) along the screw-rods.

9. The ultrasound diagnostic apparatus according to any of the preceding claims, wherein:

the main case structure (110) further includes a transducer insulation wall (218) between the transducer panel module (210) and the carrier board module (222) to separate the main case structure (110) into two relatively closed spaces, at least one end of the transducer insulation wall (218) being mounted onto an interior surface of the main case structure (110); the first relatively closed space includes the transducer panel module (210), the transceiver coupled to the transducer, and the transducer information-processing module; and the second relatively closed space includes the carrier board module (222), the PC module (224), the one or more carrier-board ports (308), and the power-supply module (230), preferably wherein the transducer insulation wall (218) substantially surrounds the first relatively closed space or the second relatively closed space and includes a material capable of eliminating or reducing signal interference between components installed in the first relatively closed space and components installed in the second relatively closed space.

10. The ultrasound diagnostic apparatus according to any of the preceding claims, wherein the I/O module (312) comprises:

one or more board-to-board connectors (802) to couple the carrier board module (222) with the

I/O module (312) to enable an inter-plug-in communication between the carrier board module (222) having the PC module (224) and the I/O module (312);

one or more user interface ports (804) coupled to a user device for reading data from the ultrasound diagnostic apparatus; and

one or more information ports (806) coupled to the transducer panel module (210) to transmit data between the transducer panel module and the carrier board module (222) having the PC module (224),

wherein the one or more board-to-board connectors (802), the one or more user interface ports (804), and the one or more information ports (806) transmit data between them via one or more data cables on the I/O module (312).

11. The ultrasound diagnostic apparatus according to any of the preceding claims, wherein:

the power-supply module (230) includes a battery and a battery insulation wall insulating the battery from other components installed in the main case structure;

the battery insulation wall includes a material capable of eliminating or reducing signal interference caused by the battery on other components in the main case structure,

preferably wherein the battery is installed in a close vicinity of a surface of the main case structure to facilitate easy removal, assembly, and maintenance of the battery and its neighboring components.

12. The ultrasound diagnostic apparatus according to any of the preceding claims, wherein the power-supply module (230) comprises:

an AC-DC converter (232); and  
a power-supply filter panel (234) installed on the AC-DC converter (232) to

insulate signal interference caused by the AC-DC converter, preferably wherein:

the AC-DC converter (232) and the power-supply filter panel (234) are placed inside an insulation box to further eliminate or minimize signal interference on other components installed in the main case structure (110).

13. The ultrasound diagnostic apparatus according to claim 12, wherein  
the main case structure (110) further comprises:

a hard drive (300); and  
a hard drive port (402) located near a top surface of the main case structure (110) to receive the hard drive and allow easy removal of the hard

drive (300).

14. The ultrasound diagnostic apparatus according to any of the preceding claims, wherein:  
the main case structure (110) further includes one or more ventilation openings aligned with one or more fans in the main case structure for heat dissipation.
15. The ultrasound diagnostic apparatus according to any of the preceding claims, wherein:  
the outer casing (120) further includes a transducer window for the transducer to pass through and couple with a transducer port (212) on the transducer panel module installed on the main case structure (110).

### Patentansprüche

1. Ultraschall Diagnosevorrichtung (100) mit einfacher Montage und Demontage, umfassend:  
ein Außengehäuse (120), das Folgendes beinhaltet:

ein Hauptplattenmodul (510) mit einem oder mehreren Hauptplattenführungssteckern (512) und einem oder mehreren darauf installierten Hauptplattenanschlüssen (514), um die Montage zu ermöglichen, und eine erste Außengehäuseverschiebevorrichtung (530); und eine Hauptgehäusestruktur (110), die von dem Außengehäuse (120) aufgenommen ist, die Folgendes beinhaltet: ein E/A-Modul (312), ein Stromversorgungsmodul (230) zum Erhalten einer Stromversorgung und Bereitstellen der Stromversorgung an die Ultraschall Diagnosevorrichtung (100), ein Wandlerplattenmodul (210), das mit dem E/A-Modul (312) gekoppelt ist und einen Sender-Empfänger und ein darauf installiertes Wandler-Informationsverarbeitungsmodul aufweist, wobei der Sender-Empfänger mit einem Wandler gekoppelt ist, um elektrische Ultraschallsignale zu emittieren und zu empfangen, und das Wandler-Informationsverarbeitungsmodul die empfangenen elektrischen Ultraschallsignale in digitale Informationen umwandelt, ein Trägerplattenmodul (222), das über das E/A-Modul (312) mit dem E/A-Modul (312) und dem Wandler-Informationsverarbeitungsmodul gekoppelt ist und ein darauf installiertes PC-Modul (224) aufweist, um die umgewandelten digitalen Informationen zu verarbeiten und die verarbeiteten digitalen Informationen an eine Ausgabevorrichtung (130) zu übertragen, die mit einem oder mehreren Hauptplattenanschlüssen (514) gekoppelt ist, wobei das PC-Modul mit dem Hauptplattenmodul gekoppelt ist, ein oder mehrere Trägerplattenfüh-

- rungslöcher (306), um den einen oder die mehreren Hauptplattenführungsstecker (512) aufzunehmen und die Baugruppe zu führen, einen oder mehrere Trägerplattenanschlüsse (308), um in den einen oder die mehreren Hauptplattenanschlüssen (514) gesteckt zu werden und die Datenkommunikation zwischen dem Hauptplattenmodul und dem Trägerplattenmodul (222) zu ermöglichen, und eine erste Hauptgehäuseverschiebevorrichtung (530), um in die erste Außengehäuseverschiebevorrichtung eingeschoben zu werden und der Hauptgehäusestruktur zu ermöglichen, sich während der Montage und Demontage in Bezug auf das Außengehäuse entlang der ersten Außengehäuseverschiebevorrichtung zu bewegen; wobei das Hauptplattenmodul (510) und das E/A-Modul (312) auf den beiden gegenüberliegenden Seiten der Hauptgehäusestruktur senkrecht zum Wandlerplattenmodul (210) und dem Trägerplattenmodul (222) installiert sind, um die einfache Montage und Demontage zu erlauben.
2. Ultraschalldiagnosevorrichtung nach Anspruch 1, ferner umfassend: eine Eingabevorrichtung (140), die mit einem oder mehreren Hauptplattenanschlüssen (514) gekoppelt ist, um von einem Benutzer bereitgestellte Steuerparameter zu empfangen, wobei das PC-Modul (224) über das Hauptplattenmodul (510) und die einen oder mehreren Hauptplattenanschlüsse (514) mit der Eingabevorrichtung (140) gekoppelt ist, um die eingegebenen Steuerparameter zu empfangen.
3. Ultraschalldiagnosevorrichtung nach Anspruch 2, wobei:  
das PC-Modul (224) den Wandler durch Folgendes steuert:  
Einstellen eines oder mehrerer Übertragungsparameter in Bezug auf eine Übertragungsfrequenz, eine Übertragungszeit und/oder einen Übertragungswinkel beruhend auf den empfangenen Steuerparametern und Übertragen des/der eingestellten einen oder mehreren Übertragungsparameter an den Sender-Empfänger über das E/A-Modul (312).
4. Ultraschalldiagnosevorrichtung nach einem der vorherigen Ansprüche, wobei:  
während der Montage die Hauptgehäusestruktur (110) entlang der ersten Verschiebevorrichtung des Außengehäuses in das Außengehäuse (120) gleitet, um zu ermöglichen, dass der eine oder die mehreren Hauptplattenführungsstecker (512) in die einen oder mehreren Führungslöcher (306) der Trägerplatte gesteckt werden und dass der eine oder die mehreren Trägerplattenanschlüsse (308) mit dem einen oder den mehreren Hauptplattenanschlüssen (514) zum Einstecken ausgerichtet sind.
5. Ultraschalldiagnosevorrichtung nach Anspruch 4, wobei:  
das Außengehäuse (120) ferner ein oder mehrere Außengehäusepositionierungslöcher (502) beinhaltet;  
und die Hauptgehäusestruktur (110) ferner eine oder mehrere Hauptgehäusepositionierungssäulen (304) beinhaltet, um in das eine oder die mehreren Außengehäusepositionierungslöcher (502) zu passen, wenn der eine oder die mehreren Trägerplattenanschlüsse (308) in den einen oder die mehreren Hauptplattenanschlüssen (514) eingesteckt sind, wobei die Hauptgehäusestruktur mit dem Außengehäuse zusammen befestigt wird.
6. Ultraschalldiagnosevorrichtung nach einem der vorherigen Ansprüche, wobei:  
die erste Außengehäuseverschiebevorrichtung (530) einen Verschiebeanschlag (1002) zum Stoppen der ersten Hauptgehäuseverschiebevorrichtung beinhaltet und die Hauptgehäusestruktur (110) einschränkt, um sich innerhalb des Außengehäuses in einem bestimmten Bereich zu bewegen, vorzugsweise wobei sich der Verschiebeanschlag (1002) in der Nähe des Endes der ersten Außengehäuseverschiebevorrichtung nahe der Seite des Außengehäuses angeordnet ist, wobei das Hauptplattenmodul (510) mit einem oder mehreren Hauptplattenanschlüssen (514) installiert wird, um die Steckverbindung zwischen dem einen oder den mehreren Trägerplattenanschlüssen (308) und dem einen oder den mehreren Hauptplattenanschlüssen (514) an der Hauptgehäusestruktur (110) zu ermöglichen, und um zu verhindern, dass der eine oder die mehreren Trägerplattenanschlüsse (308) mit dem einen oder den mehreren Hauptplattenanschlüssen zusammenstoßen.
7. Ultraschalldiagnosevorrichtung nach einem der vorherigen Ansprüche, wobei:  
die Hauptgehäusestruktur (110) ferner eine zweite Hauptgehäuseverschiebevorrichtung beinhaltet, um auf einer Innenfläche des Außengehäuses zu gleiten und der ersten Hauptgehäuseverschiebevorrichtung zu ermöglichen, sanft in die erste Außengehäuseverschiebevorrichtung zu gleiten, vorzugsweise wobei das Außengehäuse ferner eine zweite Außengehäuseverschiebevorrichtung beinhaltet, um der zweiten Hauptgehäuseverschiebevorrichtung zu ermöglichen, darin zu gleiten.
8. Ultraschalldiagnosevorrichtung nach einem der vorherigen Ansprüche, wobei:  
das Außengehäuse (120) ferner eine oder mehrere

Gewindestangen beinhaltet, die zwischen dem Außengehäuse (120) und der Hauptgehäusestruktur (110) installiert sind, wobei die Hauptgehäusestruktur mit einer oder mehreren Schraubenmuttern an den Gewindestangen gekoppelt ist, und wenn die Gewindestangen gedreht werden, bewegen sich die eine oder mehreren Schraubenmuttern linear entlang der Gewindestangen, um die Hauptgehäusestruktur (110) in das oder aus dem Außengehäuse (120) entlang der Gewindestangen zu bewegen.

9. Ultraschall Diagnosevorrichtung nach einem der vorherigen Ansprüche, wobei:

die Hauptgehäusestruktur (110) ferner eine Wandlerisolationwand (218) zwischen dem Wandlerplattenmodul (210) und dem Trägerplattenmodul (222) beinhaltet, um die Hauptgehäusestruktur (110) in zwei relativ geschlossene Räume zu trennen, wobei mindestens ein Ende der Wandlerisolationwand (218) an einer Innenfläche der Hauptgehäusestruktur (110) montiert ist; der erste relativ geschlossene Raum das Wandlerplattenmodul (210), den mit dem Wandler gekoppelten Sendempfangsmodul und das Wandler-Informationsverarbeitungsmodul beinhaltet;

und der zweite relativ geschlossene Raum das Trägerplattenmodul (222), das PC-Modul (224), den einen oder die mehreren Trägerplattenanschlüsse (308) und das Stromversorgungsmodul (230) beinhaltet, vorzugsweise wobei die Wandlerisolationwand (218) den ersten relativ geschlossenen Raum oder den zweiten relativ geschlossenen Raum im Wesentlichen umgibt und ein Material beinhaltet, das in der Lage ist, Signalstörungen zwischen Komponenten, die in dem ersten relativ geschlossenen Raum installiert sind, und Komponenten, die in dem zweiten relativ geschlossenen Raum installiert sind, zu eliminieren oder zu reduzieren.

10. Ultraschall Diagnosevorrichtung nach einem der vorherigen Ansprüche, wobei das E/A-Modul (312) Folgendes umfasst:

einen oder mehrere Platinen-Platinen-Verbinder (802), um das Trägerplattenmodul (222) mit dem E/A-Modul (312) zu koppeln, um eine Steckverbindungskommunikation zwischen dem Trägerplattenmodul (222) mit dem PC-Modul (224) und dem E/A-Modul (312) zu ermöglichen;

einen oder mehrere Benutzeroberflächenanschlüsse (804), die mit einer Benutzervorrichtung zum Lesen von Daten aus der Ultraschall Diagnosevorrichtung gekoppelt sind; und einen oder mehrere Informationsanschlüsse (806),

die mit dem Wandlerplattenmodul (210) gekoppelt sind, um Daten zwischen dem Wandlerplattenmodul und dem Trägerplattenmodul (222), das das PC-Modul (224) aufweist, zu übertragen, wobei der eine oder die mehreren Platinen-Platinen-Verbinder (802), der eine oder die mehreren Benutzeroberflächenanschlüsse (804) und der eine oder die mehreren Informationsanschlüsse (806) Daten zwischen ihnen über ein oder mehrere Datenkabel an dem E/A-Modul (312) übertragen.

11. Ultraschall Diagnosevorrichtung nach einem der vorherigen Ansprüche, wobei:

das Stromversorgungsmodul (230) eine Batterie und eine Batterieisolationwand beinhaltet, die die Batterie von anderen Komponenten isoliert, die in der Hauptgehäusestruktur installiert sind;

die Batterieisolationwand ein Material beinhaltet, das in der Lage ist, Signalstörungen, die durch die Batterie an anderen Komponenten in der Hauptgehäusestruktur verursacht werden, zu eliminieren oder zu reduzieren, vorzugsweise wobei die Batterie in unmittelbarer Nähe einer Oberfläche der Hauptgehäusestruktur installiert ist, um ein einfaches Entfernen, Montieren und Warten der Batterie und ihrer benachbarten Komponenten zu erleichtern.

12. Ultraschall Diagnosevorrichtung nach einem der vorherigen Ansprüche, wobei das Stromversorgungsmodul (230) Folgendes umfasst:

einen AC-DC-Wandler (232);  
und eine Stromversorgungsfilterplatine (234), die an dem AC-DC-Wandler (232) installiert ist, um durch den AC-DC-Wandler verursachte Signalstörungen zu isolieren, vorzugsweise wobei:

der AC-DC-Wandler (232) und die Stromversorgungsfilterplatine (234) in einem Isoliergehäuse angeordnet sind, um Signalstörungen an anderen Komponenten, die in der Hauptgehäusestruktur (110) installiert sind, weiter zu eliminieren oder zu minimieren.

13. Ultraschall Diagnosevorrichtung nach Anspruch 12, wobei die Hauptgehäusestruktur (110) ferner folgendes umfasst: eine Festplatte (300);  
und einen Festplattenanschluss (402), der sich in der Nähe einer Oberseite der Hauptgehäusestruktur (110) befindet, um die Festplatte aufzunehmen und ein einfaches Entfernen der Festplatte (300) zu ermöglichen.

14. Ultraschall Diagnosevorrichtung nach einem der vor-

herigen Ansprüche, wobei:

die Hauptgehäusestruktur (110) ferner eine oder mehrere Lüftungsöffnungen beinhaltet, die mit einem oder mehreren Ventilatoren in der Hauptgehäusestruktur zur Wärmeableitung ausgerichtet sind.

15. Ultraschalldiagnosevorrichtung nach einem der vorherigen Ansprüche, wobei:

das Außengehäuse (120) ferner ein Wandlerfenster beinhaltet, durch das der Wandler hindurchverläuft und mit einem Wandleranschluss (212) an dem Wandlerplattenmodul gekoppelt werden kann, das an der Hauptgehäusestruktur (110) installiert ist.

## Revendications

1. Appareil de diagnostic à ultrasons (100) présentant un montage et un démontage faciles, comprenant :

un boîtier externe (120) comprenant :

un module de carte-mère (510) sur lequel sont montés une ou plusieurs fiches de guidage de carte-mère (512) et un ou plusieurs ports de carte-mère (514) pour faciliter le montage, et

un premier dispositif de coulissement de boîtier externe (530) ; et

une structure de boîtier principal (110) hébergée par le boîtier externe (120), comprenant :

un module d'E/S (312),  
un module d'alimentation électrique (230) pour recevoir une alimentation électrique et fournir l'alimentation électrique à l'appareil de diagnostic à ultrasons (100),

un module de panneau transducteur (210) couplé au module d'E/S (312) et sur lequel sont montés un émetteur-récepteur et un module de traitement d'informations de transducteur, l'émetteur-récepteur étant couplé à un transducteur pour émettre et recevoir des signaux électriques d'ultrasons et le module de traitement d'informations de transducteur convertissant les signaux électriques d'ultrasons reçus en informations numériques,

un module de carte support (222) couplé au module d'E/S (312) et au module de traitement d'informations de transducteur via le module d'E/S (312) et sur lequel est installé un module de PC (224) pour traiter les informations numériques converties et transmettre les informations numériques traitées à un dispositif de sortie (130) couplé auxdits un ou plusieurs ports de carte-mère (514),

le module de PC étant couplé au module de carte-mère,

un ou plusieurs trous de guidage de carte support (306) pour recevoir lesdites une ou plusieurs fiches de guidage de carte-mère (512) et guider le montage,

un ou plusieurs ports de carte support (308) pour un inter-branchement dans lesdits un ou plusieurs ports de carte-mère (514) et faciliter les communications de données entre le module de carte-mère et le module de carte support (222), et

un premier dispositif de coulissement de boîtier principal (530) pour coulisser dans le premier dispositif de coulissement de boîtier externe et faciliter le déplacement de la structure de boîtier principale par rapport au boîtier externe le long du premier dispositif de coulissement de boîtier externe pendant le montage et le démontage ;

ledit module de carte-mère (510) et ledit module d'E/S (312) étant montés sur deux côtés opposés de la structure de boîtier principal perpendiculaires au module de panneau transducteur (210) et au module de carte support (222) pour permettre un montage et un démontage faciles.

2. Appareil de diagnostic à ultrasons selon la revendication 1, comprenant en outre :

un dispositif d'entrée (140) couplé auxdits un ou plusieurs ports de carte-mère (514) pour recevoir des paramètres de commande fournis par un utilisateur,

ledit module de PC (224) étant couplé au dispositif d'entrée (140) par l'intermédiaire du module de carte-mère (510) et auxdits un ou plusieurs ports de carte-mère (514) pour recevoir les paramètres de commandes entrés.

3. Appareil de diagnostic à ultrasons selon la revendication 2, dans lequel :

le module de PC (224) commande le transducteur par :

réglage d'un ou plusieurs paramètres de transmission se rapportant à une fréquence de transmission, un temps de transmission, et/ou un angle de transmission sur la base des paramètres de commande reçus, et transmission desdits un ou plusieurs paramètres de transmission réglés à l'émetteur-récepteur via le module d'E/S (312).

4. Appareil de diagnostic à ultrasons selon l'une quelconque des revendications précédentes, dans lequel :

pendant le montage, la structure de boîtier principal (110) coulisse dans le boîtier externe (120) le long du premier dispositif de coulissement de boîtier externe pour permettre auxdites une ou plusieurs fiches de guidage de carte-mère (512) de se brancher dans lesdits un ou plusieurs trous de guidage de carte support (306) et permettre auxdits un ou plusieurs ports de carte support (308) de s'aligner avec lesdits un ou plusieurs ports de carte-mère (514) pour l'inter-branchement.

5. Appareil de diagnostic à ultrasons selon la revendication 4, dans lequel :

le boîtier externe (120) comprend en outre un ou plusieurs trous de positionnement de boîtier externe (502) ; et  
la structure de boîtier principal (110) comprend en outre un ou plusieurs piliers de positionnement de boîtier principal (304) pour s'adapter dans lesdits un ou plusieurs trous de positionnement de boîtier externe (502) lorsque lesdits un ou plusieurs ports de carte support (308) s'inter-branchent dans lesdits un ou plusieurs ports de carte-mère (514), fixant ensemble la structure de boîtier principal au boîtier externe.

6. Appareil de diagnostic à ultrasons selon l'une quelconque des revendications précédentes, dans lequel :

le premier dispositif de coulissement de boîtier externe (530) comprend une butée de coulissement (1002) pour stopper le premier dispositif de coulissement de boîtier principal et empêcher la structure de boîtier principal (110) de se déplacer à l'intérieur du boîtier externe dans un certain intervalle,  
de préférence ladite butée de coulissement (1002) se trouvant près de l'extrémité du premier dispositif de coulissement de boîtier externe à proximité du côté du boîtier externe en montant le module de carte-mère (510) qui comporte lesdits un ou plusieurs ports de carte-mère (514) pour permettre l'inter-branchement entre lesdits un ou plusieurs ports de carte support (308) et lesdits un ou plusieurs ports de carte-mère (514) sur la structure de boîtier principal (110) et empêcher lesdits un ou plusieurs ports de carte support (308) de heurter lesdits un ou plusieurs ports de carte-mère.

7. Appareil de diagnostic à ultrasons selon l'une quelconque des revendications précédentes, dans lequel :

la structure de boîtier principal (110) comprend en outre un second dispositif de coulissement

de boîtier principal pour coulisser sur une surface intérieure du boîtier externe et faciliter le coulissement sans heurt du premier dispositif de coulissement de boîtier principal dans le premier dispositif de coulissement de boîtier externe,  
de préférence ledit boîtier externe comprenant en outre un second dispositif de coulissement de boîtier externe pour permettre au second dispositif de coulissement de boîtier principal de coulisser dans celui-ci.

8. Appareil de diagnostic à ultrasons selon l'une quelconque des revendications précédentes, dans lequel :

le boîtier externe (120) comprend en outre une ou plusieurs tiges de vis montées entre le boîtier externe (120) et la structure de boîtier principal (110), la structure de boîtier principal étant couplée à une ou plusieurs écrous de vis sur les tiges de vis, et  
lorsque les tiges de vis tournent, lesdits un ou plusieurs écrous de vis se déplacent le long des tiges de vis linéairement pour déplacer la structure de boîtier principal (110) dans ou hors du boîtier externe (120) le long des tiges de vis.

9. Appareil de diagnostic à ultrasons selon l'une quelconque des revendications précédentes, dans lequel :

la structure de boîtier principal (110) comprend en outre une paroi d'isolation de transducteur (218) entre le module de panneau transducteur (210) et le module de carte support (222) pour diviser la structure de boîtier principal (110) en deux espaces relativement fermés, au moins une extrémité de la paroi d'isolation de transducteur (218) étant montée sur une surface intérieure de la structure de boîtier principal (110) ; le premier espace relativement fermé comprend le module de panneau transducteur (210), l'émetteur-récepteur couplé au transducteur et le module de traitement d'informations de transducteur ; et  
le second espace relativement fermé comprenant le module de carte support (222), le module de PC (224), lesdits un ou plusieurs ports de carte support (308) et le module d'alimentation électrique (230),  
de préférence ladite paroi d'isolation de transducteur (218) entourant sensiblement le premier espace relativement fermé ou le second espace relativement fermé et comprenant un matériau pouvant éliminer ou réduire les interférences de signaux entre les composants montés dans le premier espace relativement fermé et les com-

posants montés dans le second espace relativement fermé.

10. Appareil de diagnostic à ultrasons selon l'une quelconque des revendications précédentes, dans lequel le module d'E/S (312) comprend :

un ou plusieurs connecteurs de carte à carte (802) pour coupler le module de carte support (222) au module d'E/S (312) pour permettre une communication par inter-branchement entre le module de carte support (222) comportant le module de PC (224) et le module d'E/S (312) ; un ou plusieurs ports d'interface utilisateur (804) couplés à un dispositif utilisateur pour lire les données provenant de l'appareil de diagnostic à ultrasons ; et

un ou plusieurs ports d'informations (806) couplés au module de panneau transducteur (210) pour transmettre des données entre le module de panneau transducteur et le module de carte support (222) comportant le module de PC (224),

lesdits un ou plusieurs connecteurs de carte à carte (802), lesdits un ou plusieurs ports d'interface utilisateur (804) et lesdits un ou plusieurs ports d'informations (806) transmettant des données entre eux via un ou plusieurs câbles de données sur le module d'E/S (312).

11. Appareil de diagnostic à ultrasons selon l'une quelconque des revendications précédentes, dans lequel :

le module d'alimentation électrique (230) comprend une batterie et une paroi d'isolation de batterie isolant la batterie des autres composants montés dans la structure de boîtier principal ;

la paroi d'isolation de batterie comprend un matériau pouvant éliminer ou réduire les interférences de signaux provoqués par la batterie sur d'autres composants dans la structure de boîtier principal,

de préférence ladite batterie étant montée à proximité immédiate d'une surface de la structure de boîtier principal pour faciliter un retrait, un montage et une maintenance faciles de la batterie et des composants voisins.

12. Appareil de diagnostic à ultrasons selon l'une quelconque des revendications précédentes, dans lequel le module d'alimentation électrique (230) comprend :

un convertisseur CA-CC (232) ; et  
un panneau de filtre d'alimentation électrique (234) installé sur le convertisseur CA-CC (232)

pour isoler les interférences de signaux provoquées par le convertisseur CA-CC, de préférence dans lequel :

le convertisseur CA-CC (232) et le panneau de filtre d'alimentation électrique (234) sont placés à l'intérieur d'une boîte d'isolation pour en outre éliminer ou minimiser les interférences de signaux sur d'autres composants montés dans la structure de boîtier principal (110).

13. Appareil de diagnostic à ultrasons selon la revendication 12, ladite structure de boîtier principal (110) comprenant en outre :

un disque dur (300) ; et  
un port de disque dur (402) situé près d'une surface supérieure de la structure de boîtier principal (110) pour recevoir le disque dur et permettre un retrait facile du disque dur (300).

14. Appareil de diagnostic à ultrasons selon l'une quelconque des revendications précédentes, dans lequel :

la structure de boîtier principal (110) comprend en outre une ou plusieurs ouvertures de ventilation alignées avec un ou plusieurs ventilateurs dans la structure de boîtier principal pour la dissipation de chaleur.

15. Appareil de diagnostic à ultrasons selon l'une quelconque des revendications précédentes, dans lequel :

le boîtier externe (120) comprend en outre une fenêtre de transducteur pour que le transducteur passe à travers et se couple à un port de transducteur (212) sur le module de panneau transducteur monté sur la structure de boîtier principal (110).

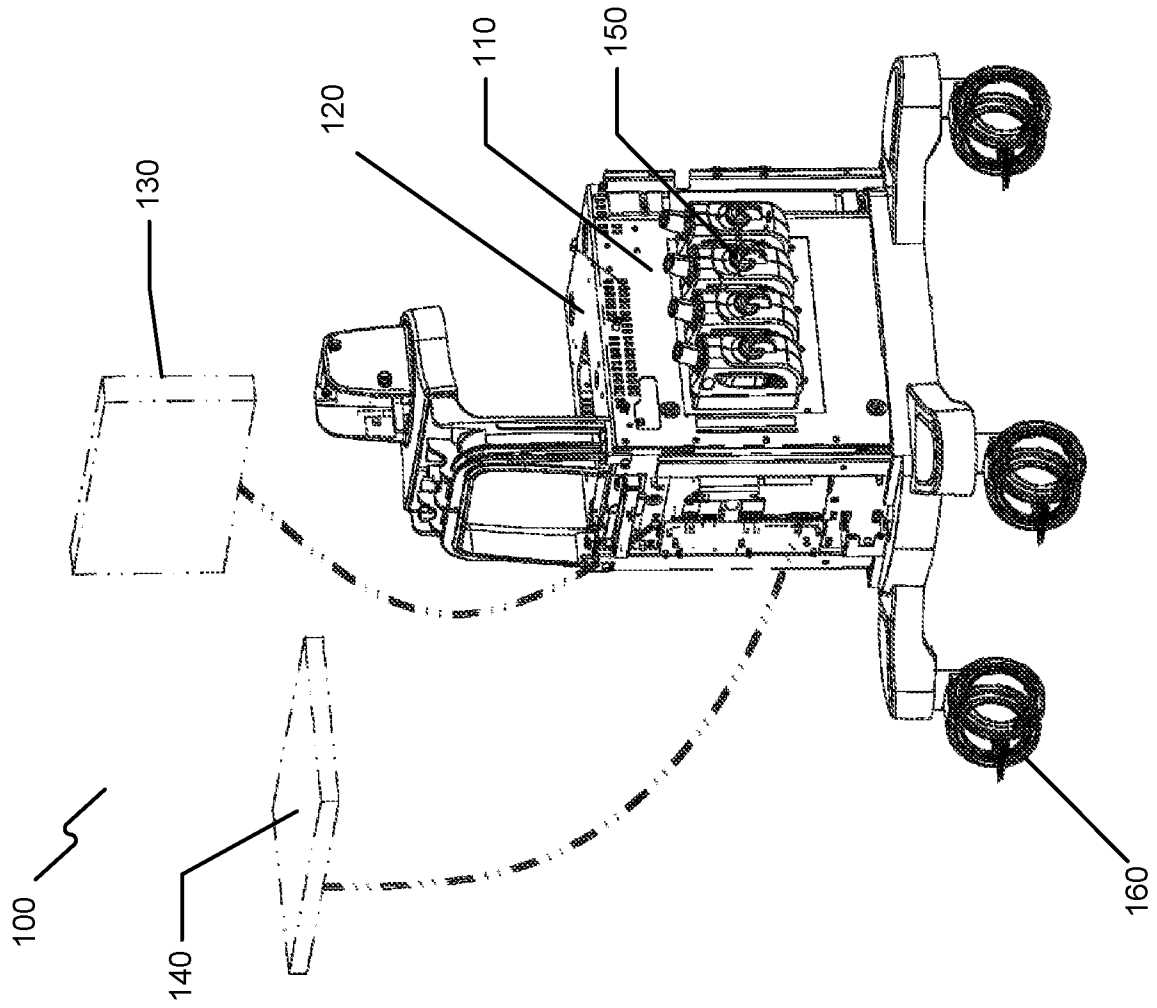

FIG. 1

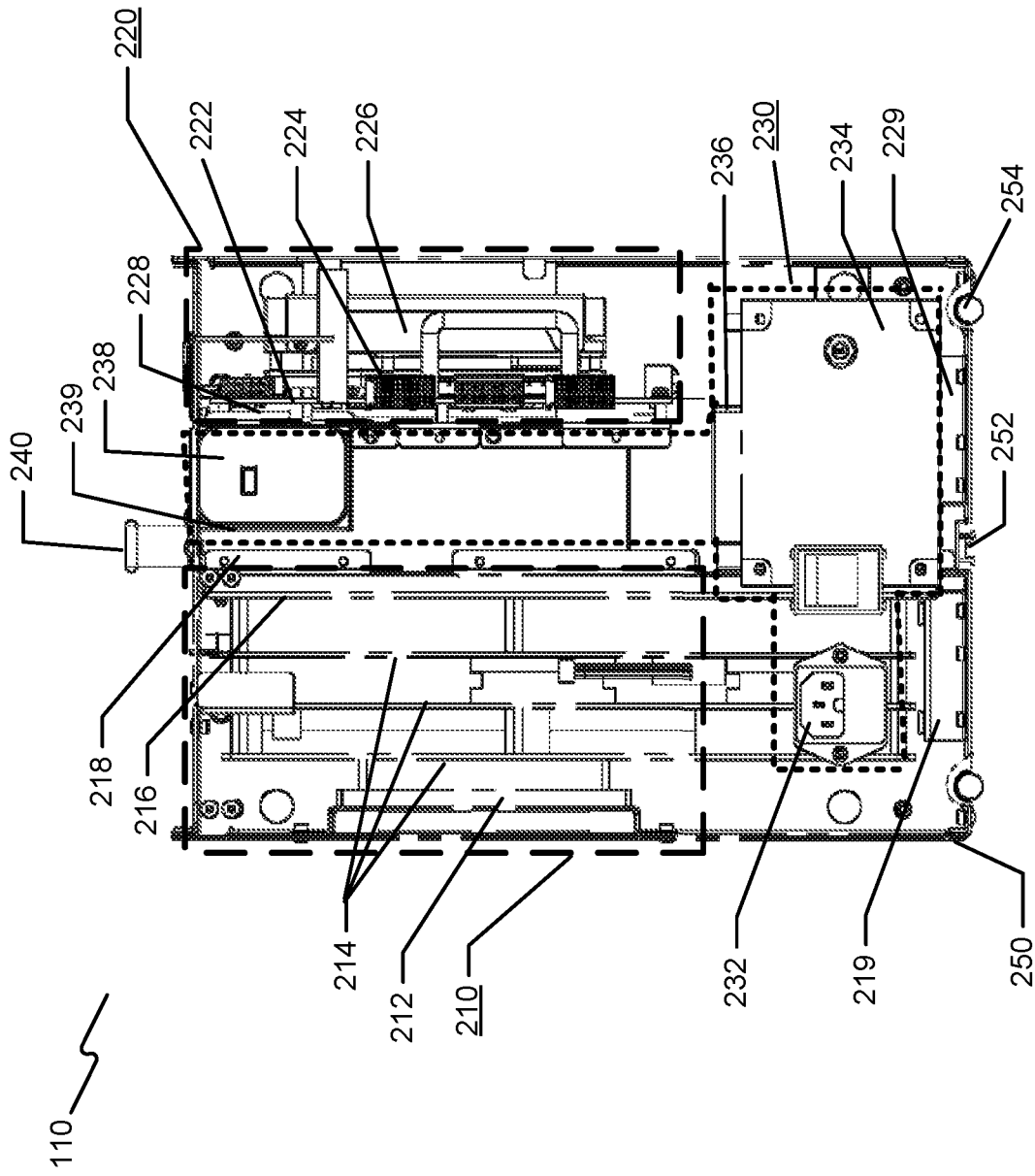

FIG. 2

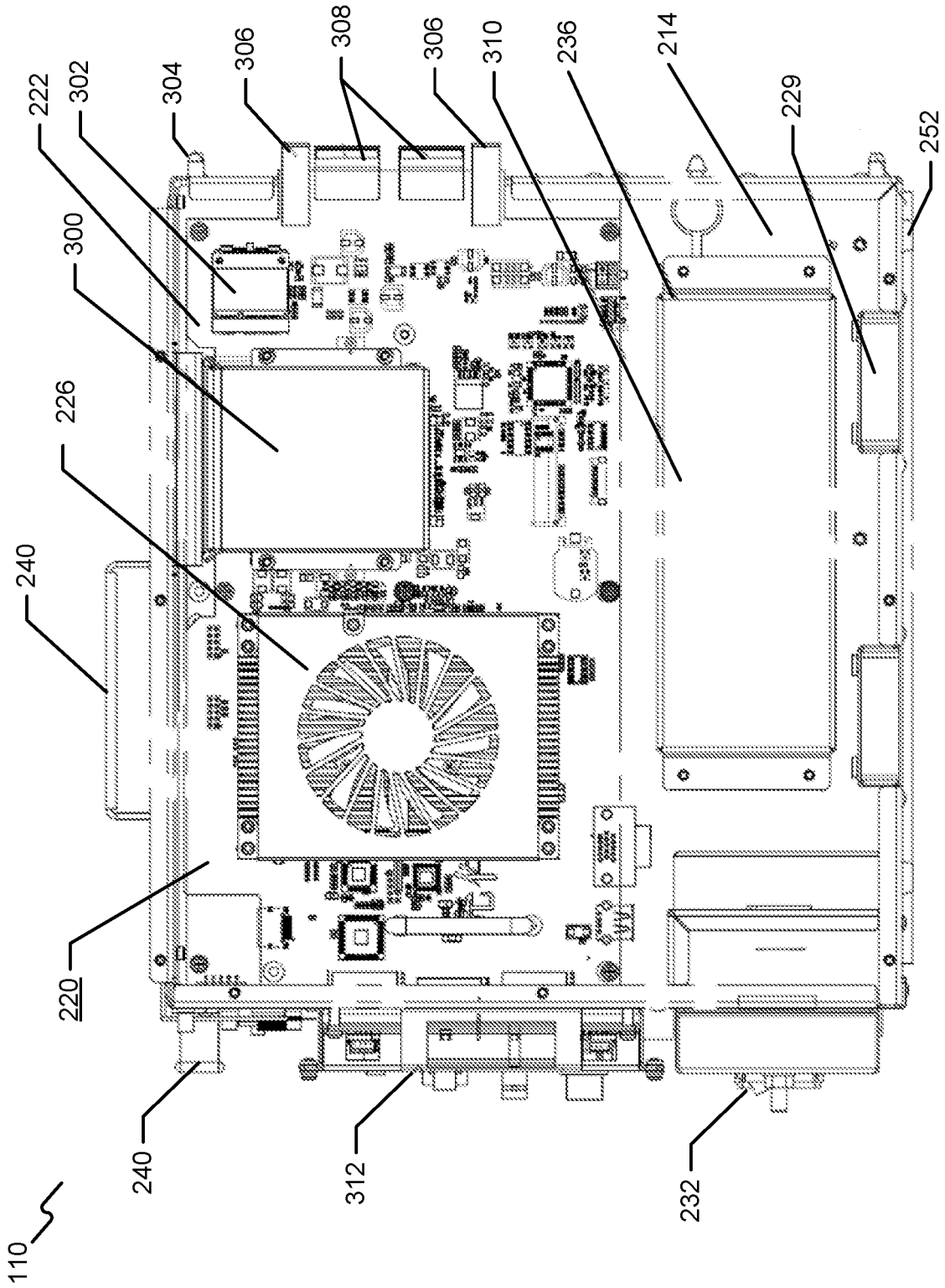

FIG. 3

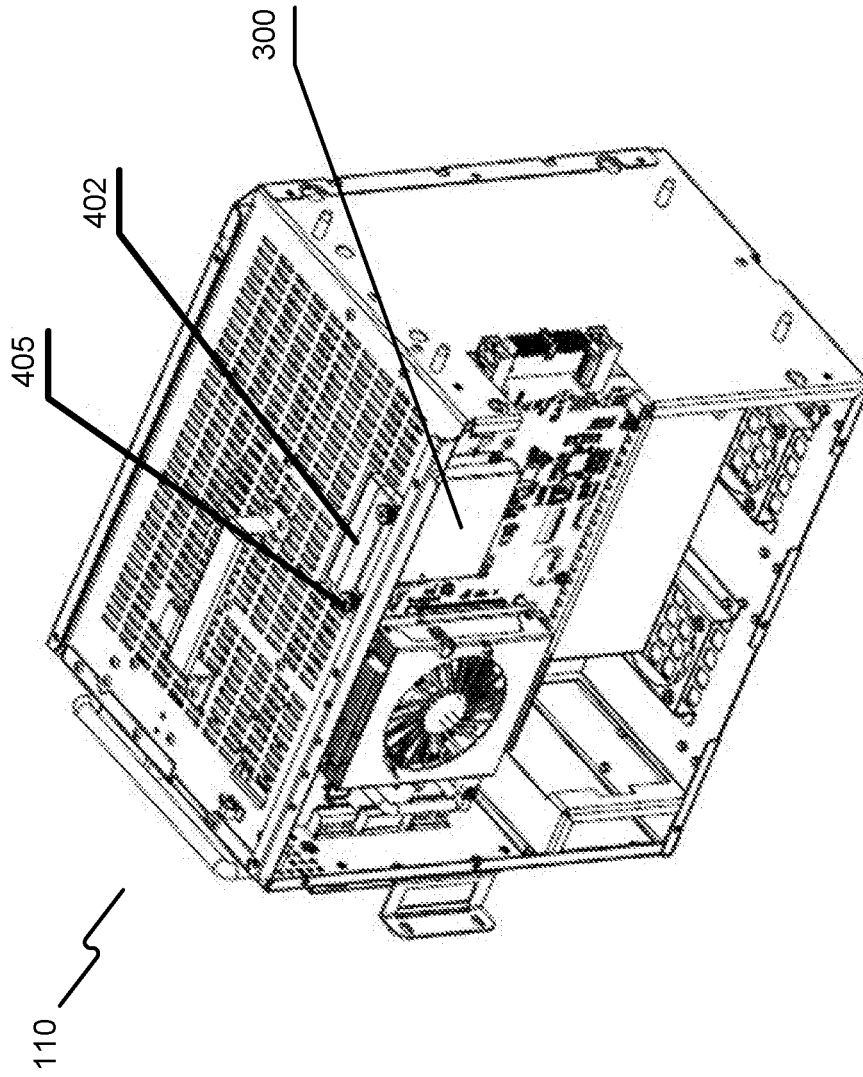

FIG. 4

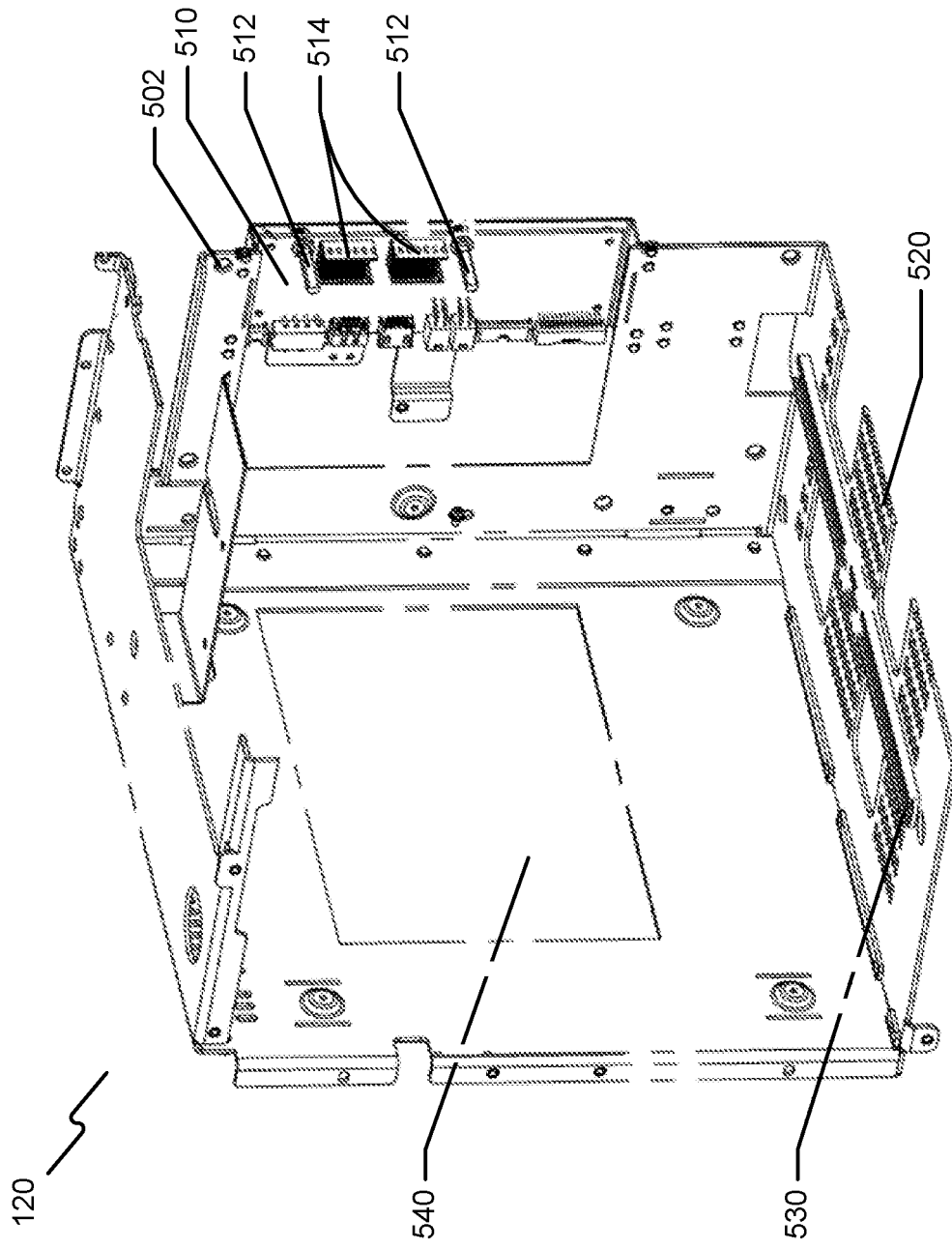

FIG. 5

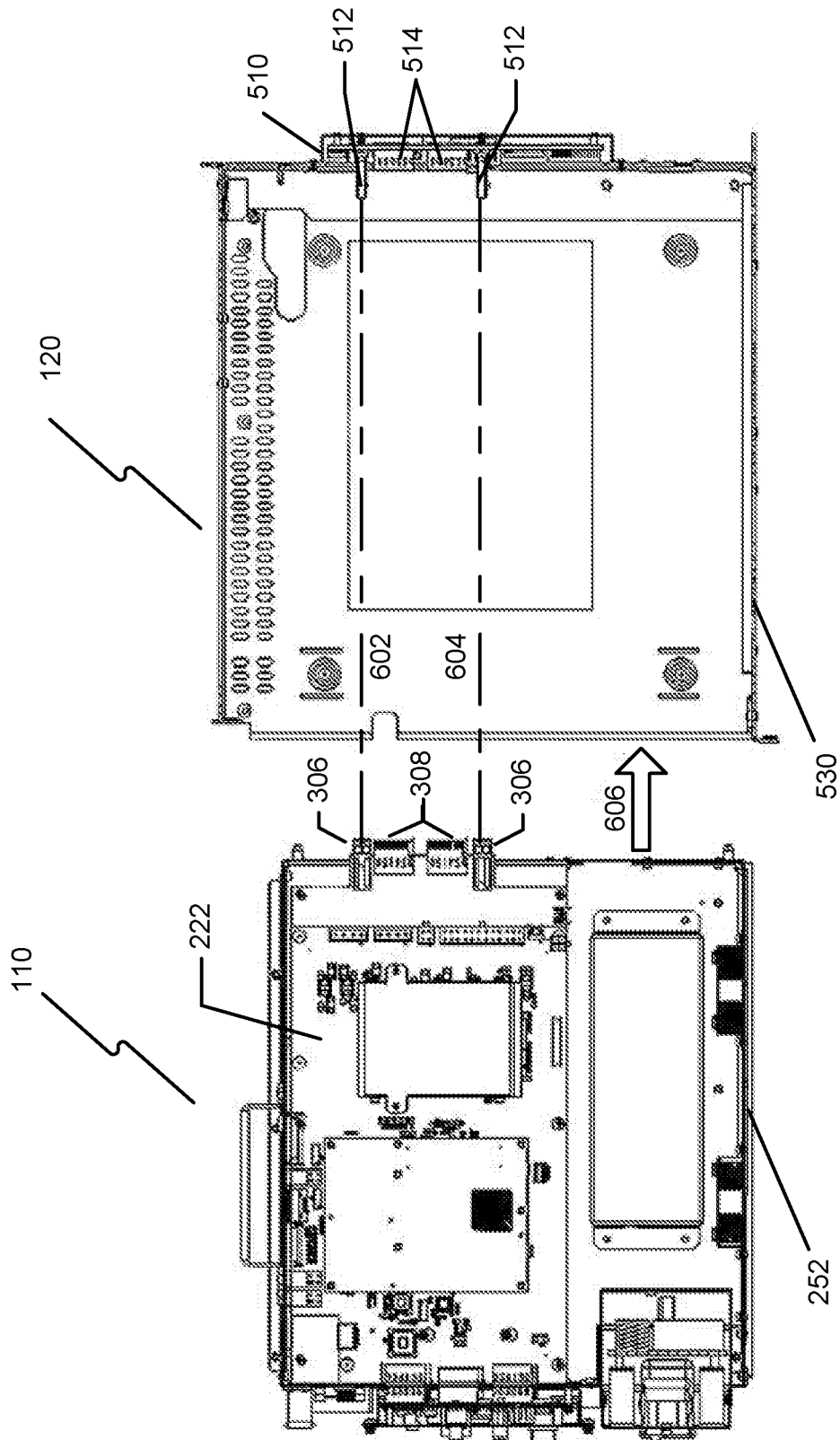

FIG. 6

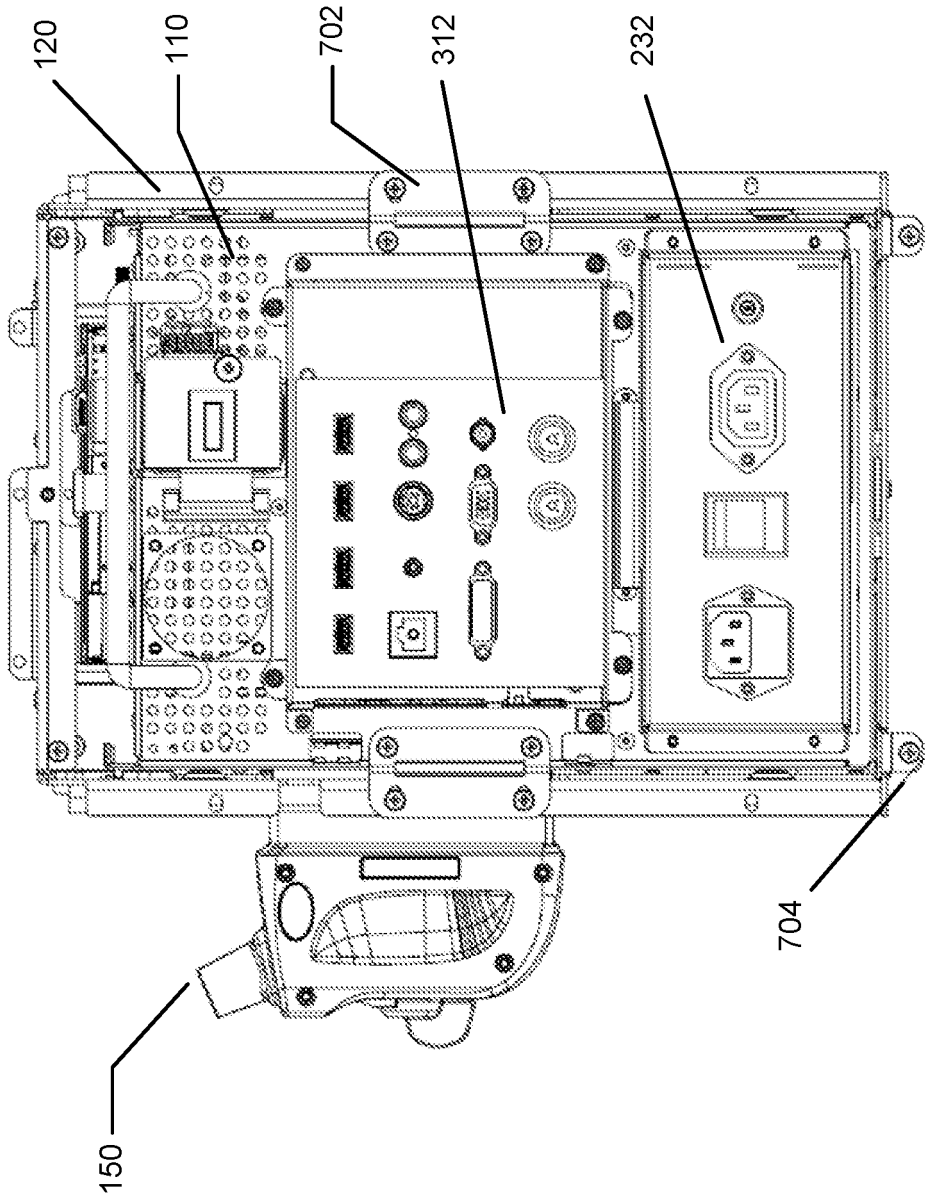

FIG. 7

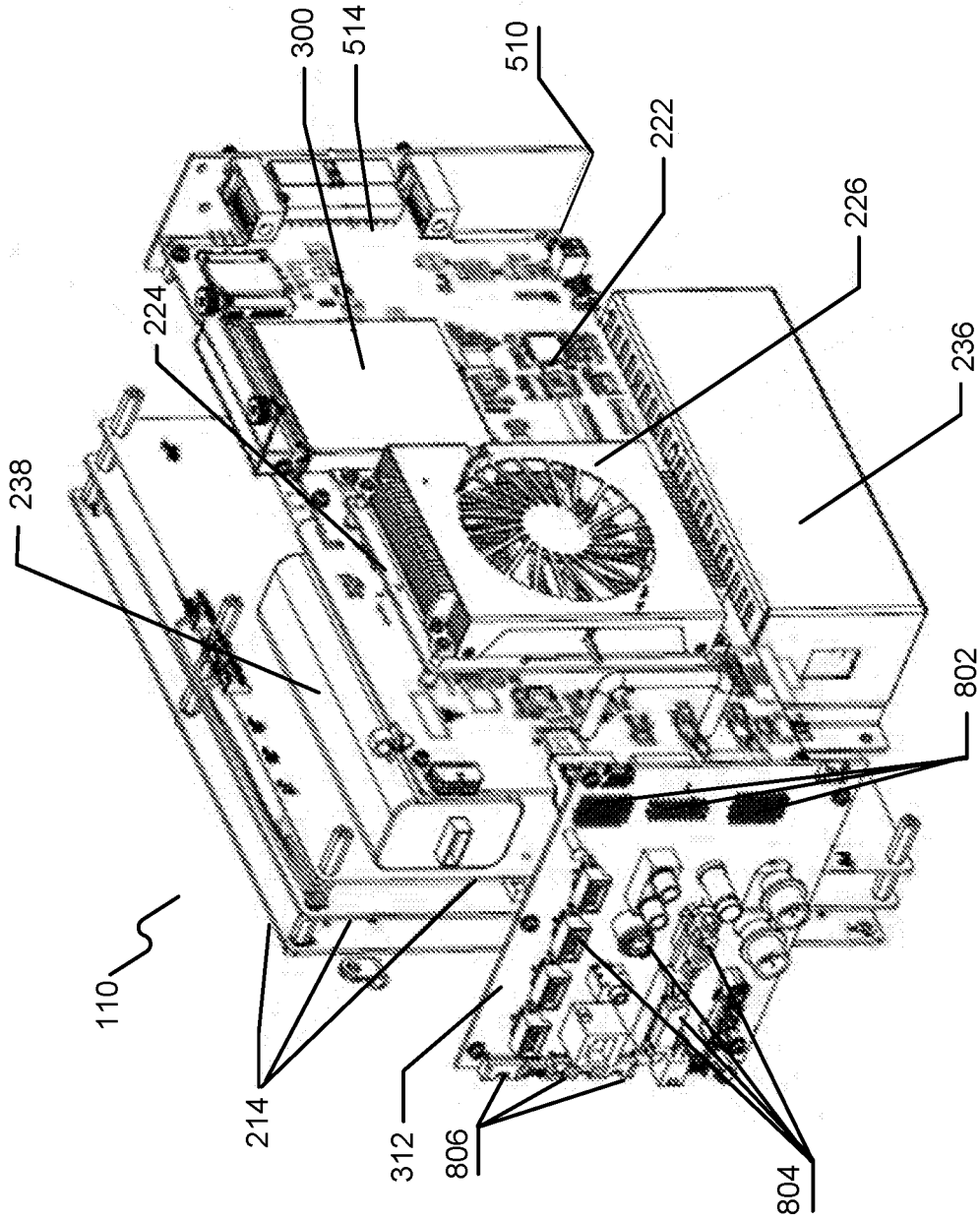

FIG. 8

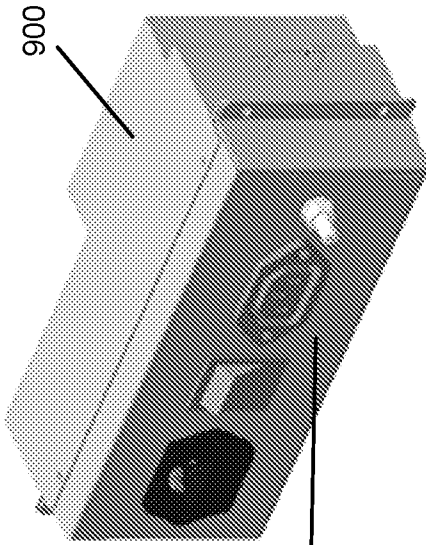

FIG. 9B

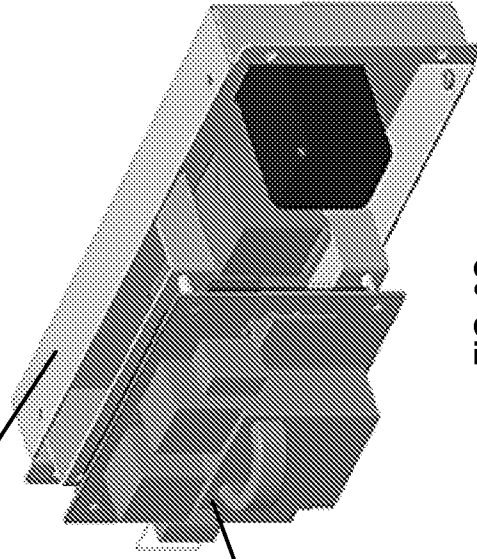

FIG. 9C

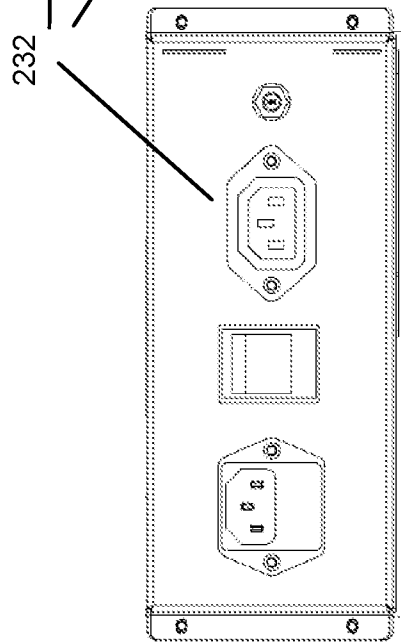

FIG. 9A

FIG. 9A-C

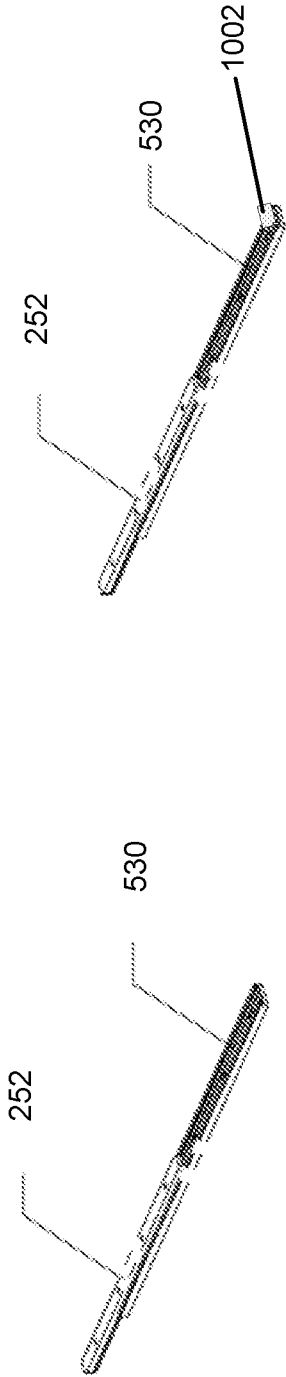

FIG. 10B

FIG. 10A

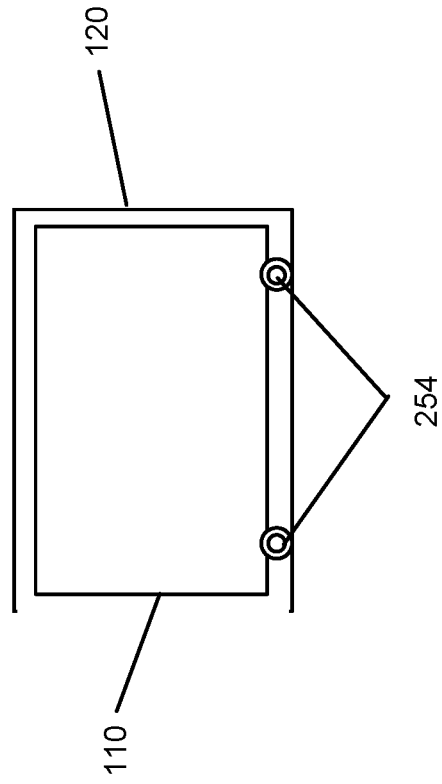

FIG. 10C

FIG. 10A-C

**REFERENCES CITED IN THE DESCRIPTION**

*This list of references cited by the applicant is for the reader's convenience only. It does not form part of the European patent document. Even though great care has been taken in compiling the references, errors or omissions cannot be excluded and the EPO disclaims all liability in this regard.*

**Patent documents cited in the description**

- CN 104306020 A [0004]

专利名称(译)	超声诊断设备，易于组装和拆卸		
公开(公告)号	<a href="#">EP3125769B1</a>	公开(公告)日	2019-05-15
申请号	EP2016761101	申请日	2016-03-09
[标]申请(专利权)人(译)	CHISON医学影像		
申请(专利权)人(译)	CHISON医学影像CO., LTD.		
[标]发明人	SUN DONGDONG PENG CHUNLIN LU JIAN		
发明人	SUN, DONGDONG PENG, CHUNLIN LU, JIAN		
IPC分类号	A61B8/00		
CPC分类号	A61B8/4411 A61B8/00 A61B8/14 A61B8/4405 A61B8/4483 A61B8/467 A61B8/5207 A61B8/54 A61B8/56		
优先权	201510640528.X 2015-09-30 CN 201510105029.0 2015-03-10 CN		
其他公开文献	EP3125769A1 EP3125769A4		
外部链接	<a href="#">Espacenet</a>		

摘要(译)

本公开包括具有易于组装和拆卸的超声诊断设备。该装置包括外壳，该外壳包括主板模块和第一外壳滑动装置，主板模块具有安装在其上的主板引导插头和主板端口。壳体结构由外壳容纳，包括连接到I/O模块的换能器面板模块，载板模块通过I/O模块连接到换能器面板模块并且其上安装有PC模块处理超声波数据，用于接收主板引导插头的载板引导孔，用于插入主板端口的载板端口，以及用于在第一外壳滑动装置中滑动的第一主壳滑动装置，以便于主壳体结构相对于外壳移动；其中主板模块和I/O模块垂直于换能器面板模块和载板模块。

