

(19)



Europäisches Patentamt
European Patent Office
Office européen des brevets



(11)

EP 1 111 404 B1

(12)

EUROPEAN PATENT SPECIFICATION

(45) Date of publication and mention
of the grant of the patent:
29.03.2006 Bulletin 2006/13

(51) Int Cl.:
G01S 15/89 (2006.01) G01S 7/52 (2006.01)

(21) Application number: **00311498.0**

(22) Date of filing: **20.12.2000**

(54) **Ultrasound color flow adaptive scanning techniques**

Adaptive Abtasttechniken für Farbdoppler Sonographie

Techniques adaptives de balayage d'un affichage couleur ultrasonore

(84) Designated Contracting States:
DE NL

(30) Priority: **21.12.1999 US 468181**

(43) Date of publication of application:
27.06.2001 Bulletin 2001/26

(73) Proprietor: **GENERAL ELECTRIC COMPANY
Schenectady, NY 12345 (US)**

(72) Inventors:
• **Muzilla, David John
Mukwonago,
Wisconsin 53149 (US)**

• **Rhyne, Theodore Lauer
Whitefish Bay,
Wisconsin 53211 (US)**

(74) Representative: **Pedder, James Cuthbert et al
London Patent Operation,
General Electric International, Inc.,
15 John Adam Street
London WC2N 6LU (GB)**

(56) References cited:
**US-A- 4 209 853 US-A- 4 530 363
US-A- 4 932 415 US-A- 5 562 097
US-A- 5 957 138**

EP 1 111 404 B1

Note: Within nine months from the publication of the mention of the grant of the European patent, any person may give notice to the European Patent Office of opposition to the European patent granted. Notice of opposition shall be filed in a written reasoned statement. It shall not be deemed to have been filed until the opposition fee has been paid. (Art. 99(1) European Patent Convention).

Description

[0001] This invention relates to ultrasound color flow imaging, and more particularly relates to such imaging based on a portion of a subject in which fluid flow is identified.

[0002] A conventional ultrasound system typically interleaves B-mode imaging with color flow imaging. The color flow vectors from the color flow imaging are formed over the entire color flow region of interest (ROI) for every acoustic frame. These color flow vectors typically are contained in several interleave groups across the ROI. Every vector position in the color flow ROI is sampled and processed for every acoustic frame before display. As a result, a large amount of processing is required in order to produce a color flow image of the entire region of interest. In addition, a large amount of memory is normally required and a substantial reduction in frame rate may occur. This invention addresses these problems and provides a solution.

[0003] A preferred embodiment is useful in an ultrasound imaging system for displaying a color flow image representing at least a portion of a subject being studied. In such an environment, the preferred embodiment transmits ultrasound waves toward a first portion of the subject and receives first reflected ultrasound waves from the first portion. The transmitting and receiving preferably are accomplished with a transducer assembly. A first set of signals is generated having first values related to the velocity components of the fluid flow in the first portion of the subject in response to the first reflected ultrasound waves. The first values are analyzed to identify flow data representing a region of fluid flow within the first portion of the subject. The generating and analyzing preferably is accomplished with a processor. Ultrasound waves are transmitted toward a second portion of the subject and second reflected ultrasound waves are received from the second portion such that the second portion of the subject is smaller than the first portion and includes at least some of the region of fluid flow. The transmitting toward the second portion preferably is accomplished with the transducer assembly. A second set of signals is generated having second values related to velocity components of the fluid flow in the second portion of the subject in response to the second reflected ultrasound waves. The second scan values are processed to generate processed color flow data for display as a color flow image. The generating of the second set of signals and the processing preferably are done with the processor. A color flow image is displayed in response to the processed color flow data.

[0004] By using the foregoing techniques, the tissue interrogation and/or color flow processing required in a clinical examination may be substantially reduced. A reduction in interrogation and/or processing may be used in various ways to increase the average acoustic frame rate, improve color flow sensitivity and resolution, reduce processing and memory loads and increase color flow

regions of interest without unduly sacrificing frame rate.

[0005] The above advantages have been achieved by means of the apparatus and method defined in the appended claims.

The invention will now be described in greater detail, by way of example, with reference to the drawings, in which:-

Figure 1 is a schematic block diagram of a preferred form of apparatus made in accordance with the present invention.

Figure 2 is a schematic block diagram showing in more detail a portion of the apparatus as shown in Figure 1.

Figure 3 is a schematic diagram illustrating the division of a survey frame over a region of interest and target frames which contain data indicative of fluid flow.

Figure 4 is a schematic diagram illustrating a reduction in the number of target frames compared to the illustration of Figure 3.

Figure 5 is a schematic illustration of a target frame with adjacent buffer vectors and regions.

Figure 6 is a schematic illustration of a target frame in which only regions including flow data are subjected to color flow processing.

[0006] US-A-4 530363 discloses a transducer array operable for sector scanning and as near-field Doppler transducer.

[0007] Referring to Figure 1, a preferred form of the invention comprises an imaging system 10 for displaying a color flow image of a subject S being studied. System 10 includes a transducer and agile beam former assembly 20 of the type described in Patent No. U.S. 5,653,236 (Miller, issued August 5, 1997) (the "'236 Patent"). Assembly 20 transmits ultrasound waves toward a controllable portion of subject S along an axis 36 and receives reflected ultrasound waves from the portion along the same axis 36 in the manner described in the '236 Patent. Assembly 20 generates signals in response to the reflected ultrasound waves which are transmitted over a bus 40 to an adaptive color flow processing module 70. The direction of axis 36 is controlled by control signals received over a bus 50 from an adaptive scan sequencer controller 60. Controller 60 controls the angle of axis 36 in the manner described in the '236 Patent.

[0008] Referring to Figures 1 and 2, processing module 70 comprises a processor unit 74 which may include one or more individual processors. For example, processor unit 74 may include a survey frame processor 80 comprising an arithmetic unit 82, FIFO units 84 and 86 and a memory 88 connected as shown. Processor unit 74 also may comprise a target frame processor 90 com-

prising an arithmetic unit 92, FIFO units 94 and 96 and a memory 98 connected as shown. Processor unit 74 also may include other processors, such as processors 100 and 110, which are identical to processor 80. Each of processors 80, 90, 100, and 110 may comprise a digital signal processor, such as model TMS 320C6201 manufactured by Texas Instruments. The processors shown in Figure 2 are interconnected by communication busses 120-122, and processor 110 communicates with a standard logic 700 slave VME interface (I/F) 130 over a communication bus 132.

[0009] Processor unit 74 receives data over an input bus 140 from an input control and scan bus interface (I/F) 150 which comprises a field programmable gate array (FPGA). Interface 130 communicates with interface 150 over a communication bus 160. In addition, interface 130 provides output signals over a bus 164 to controller 60 (Figure 1).

[0010] Processor unit 74 provides output data on an output bus 170 to an output control unit 180 which comprises a field programmable gate array (FPGA). Control unit 180 communicates with interface 130 over a communication bus 190 reads and writes data to and from an SRAM memory 200 over busses 202 and 204. Control unit 180 provides color flow data for display over an output bus 210 to a conventional scan conversion and display processing unit 220 (Figure 1). The color flow data is converted to a corresponding image created on a display 230.

[0011] Referring to Figures 1-3, processor 80 issues a command which results in a signal transmitted over bus 164 to controller 60 that results in assembly 20 transmitting ultrasound waves toward a region of interest (ROI) of subject S and receiving reflected ultrasound waves from the ROI. The reflected waves are processed by processor 80 into a survey frame SF1 (Figure 3) which includes four equally sized interleaved groups of data G1 - G4 stored in memory 88. Processor 80 processes the data in groups G1 - G4 and determines that only the data in groups G2 and G3 result from fluid flow in the ROI. As a result, processor 80 issues another command which results in a second signal transmitted over bus 164 to controller 60 that causes assembly 20 to again transmit a second group of ultrasound waves toward the portions of subject 80 that resulted in data groups G2 and G3 in frame SF1.

[0012] As can be seen from Figure 3, the portion of the subject scanned by the second group of ultrasound waves is substantially smaller than the ROI portion of the subject indicated in frame SF1. The data resulting from the second group of reflected ultrasound waves is transmitted to the target frame processor 90 which color flow processes only the data resulting from groups G2 and G3 as shown in Figure 3. As shown in Figure 3, target frames TF1 - TF3 include only data groups G2 and G3, whereas survey frame SF1 includes not only data groups G2 and G3, but also data groups G1 and G4.

[0013] Processor 90 processes the data on bus 140

resulting from the second group of reflected ultrasound waves to form target frame groups G2 and G3 which include a set of signals having values related to the velocity components of the fluid flow in the portion of subject S represented by data groups G2 and G3. Data in groups G2 and G3 is color flow processed by processor 90 to generate color flow data which is transmitted over output bus 170 to control unit 180 which, in turn, transmits color flow data over bus 210 to scan conversion and display processing unit 220. By well known means, unit 220 displays the resulting color flow images on display unit 230. Since only the portion of the ROI represented by data groups G2 and G3 are scanned by assembly 20 and processed by processor 90, they're typically is time for more target frames than survey frames. As a result, Figure 3 shows target frames TF1 - TF3 resulting from a single survey frame SF1.

[0014] If all four frames, SF 1 and TF1 - TF3, were scanned and processed in their entirety according to conventional color flow techniques, the scanning and processing load would be 100%. However, with the example shown in Figure 3, only half of the vectors in each target frame need to be scanned, sampled and processed. This corresponds to a scanning and processing load of only 62.5% for a potential savings of 37.5%. The extra frame rate achieved by the technique shown in Figure 3, could be accepted or the packet size and/or vector density could be increased to achieve more color flow sensitivity and resolution. The survey and target frames shown in Figure 3 are continuously repeated during scanning of subject S as long as the described conditions remain the same.

[0015] Referring to Figure 4, if the average acoustic frame rate were significantly lower, or if the flow state were changing significantly faster than in the Figure 3 example, the number of target frames may need to be reduced to, for example, only a single target frame TF1 as shown in Figure 4. For the case shown in Figure 4, the scanning and processing load would be reduced to 75%, for a potential savings of 25%.

[0016] The examples of Figures 3 and 4 illustrate an ideal situation in which fluid flow corresponds exactly to the vectors within interleave groups G2 and G3. In the most general implementation of the preferred embodiment, the target frame firing decisions could be made on a vector-by-vector basis. In the examples of Figures 3 and 4, the target frame scanning decisions are constrained to interleave groups (e.g., either scan and process an interleave group, such as group G2, or none of the group). Scanning and processing limited to entire interleave groups (e.g., group G2) would be easier to implement, but would not, in general, yield significant improvements as often as decisions made on a vector-by-vector basis.

[0017] Referring to Figure 5, buffer flow vectors may be added in buffer regions, such as BR1 and BR2, in order to make the preferred embodiment more robust and less sensitive to motion. For example, in a region of

interest including data groups G1, G2, and G^A as shown in Figure 5, buffer regions BR1 and BR2 may lie on either side of a region R in which fluid flow occurs. More generally, for every vector determined to have flow on a survey frame, some number, b, of adjacent buffer vectors might also be fired and sampled on target frames. This procedure minimizes the reduced sampling benefit on a given target frame, but improves over-all imaging performance. As shown in Figure 5, buffer vectors are illustrated on either side of the fluid flow region R to create two buffer regions BR1 and BR2 of extra vectors that are scanned, sampled and processed in a target frame consisting of group G2 by processor 90. As shown in Figure 5, the target frame would include only a data group- G2 and buffer regions BR1 and BR2.

[0018] Referring to Figure 6, according to the preferred embodiment, the efficiency of the system may be further improved by selectively processing only those vector range samples in which flow is known to exist. In this way, the survey frame provides range intervals over which flow is detected, and the target frame provides adaptive color flow processing for only those range intervals. Such a procedure does not increase the frame rate, but reduces the color flow processing load in the range dimension as well as in the lateral dimension, as a function of the amount of flow in the ROI. This reduced processing load can be traded off against reduced hardware costs, covering a wider ROI, or using the processing hardware assets of the imager to provide improved color flow performance (e.g., better detection, better resolution, etc.).

[0019] Still referring to Figure 6, processor 80 processes survey frame SF2 with a color flow processing algorithm which identifies pixels having valid color flow information and sets up a region around these pixels on which parameter estimation and other color flow processing functions are performed on subsequent target frames. Pixel location in R-theta space is managed for subsequent scan version. In addition, an adequate buffer area, such as buffer regions BR1 and BR2 shown in Figure 5, may be incorporated into the regions to be processed in Figure 6 for the purpose of making the mechanization less sensitive to motion.

[0020] Still referring to Figure 6, the entire region of interest (ROI) is scanned by assembly 20 and the resulting reflected ultrasound waves are processed by processor 80 in order to form a survey frame SF2. Processor 80 identifies regions R2 and R3 as the only regions in which fluid flow data exists. As a result, processor 80 sends a signal over bus 164 to controller 60 that causes assembly 20 to again scan the subject only in regions R2 and R3. The resulting reflected ultrasound waves from regions R2 and R3 are processed by processor 90 into corresponding target frames. Adaptive color flow processing is only performed on the data resulting from regions R2 and R3 so that only regions R2 and R3 result in a color flow image on display 230. However, since regions R2 and R3 are much smaller than the entire re-

gion of interest, additional target frames may be processed for each survey frame or the data may be manipulated in the ways previously described in order to take advantage of the reduced processing time required for regions R2 and R3.

[0021] Those skilled in the art will recognize that only the preferred embodiments have been described in connection with Figures 1-6, and that those embodiments may be altered and modified without departing from the scope of the invention as defined in the accompanying claims. For example, processors 80 and 90 may be combined into a single processor, such as a single digital signal processor or microprocessor. In addition, all of the processors 80, 90, 100 and 110 may be combined into a single processor, such as a digital signal processor or a microprocessor.

Claims

1. Apparatus for use in an ultrasound imaging system (10) for displaying a color flow image representing at least a portion of a subject being studied, the apparatus comprising in combination:

a transducer assembly (20) operable in response to a first command for transmitting ultrasound waves toward a first portion of the subject and receiving first reflected ultrasound waves from the first portion and operable in response to a second command for transmitting ultrasound waves toward a second portion of the subject and receiving second reflected ultrasound waves from the second portion;

a processor (74) connected to generate the first command, to generate a first set of signals having first values related to fluid flow in said first portion of the subject in response to the first reflected ultrasound waves, and **characterized** to analyze the first values to identify flow data representing a region of fluid flow within the first portion of the subject to generate said second command such that the second portion of the subject is smaller than the first portion and includes at least some of the region of fluid flow identified by said processor (74) upon analyzing the first values, to generate a second set of signals having second values related to fluid flow in said second portion of the subject in response to the second reflected ultrasound waves and to process the second values to generate processed color flow data for display as a color flow image; and

a display (230) displaying a color flow image in response to said processed color flow data.

2. Apparatus, as claimed in claim 1. wherein said processor (74) generate multiple second commands for

each generation of said first command.

3. Apparatus, as claimed in claim 1 or 2, wherein said first portion is divided into a plurality of subportions and wherein said processor generates said second command so that the second portion includes the subportions containing any of said region of fluid flow.
4. Apparatus, as claimed in claim 1, 2 or 3, wherein said second portion includes the region of fluid flow and a buffer region adjacent said region of fluid flow.
5. Apparatus, as claimed in any preceding claim, wherein said processor (74) analyzes the second values to identify second flow data representing a region of fluid flow within the second portion of the subject and processes with adaptive color flow processing only the second flow data, so that the color flow data represents only the region of fluid flow within the second portion of the subject.
6. A method for use in an ultrasound imaging system (10) for displaying a color flow image representing at least a portion of a subject being studied, the method comprising in combination:

transmitting ultrasound waves toward a first portion of the subject and receiving first reflected ultrasound waves from the first portion;
 generating a first set of signals having first values related to fluid flow in said first portion of the subject in response to the first reflected ultrasound waves;
 analyzing the first values to identify flow data representing a region of fluid flow within the first portion of the subject, **characterized in that**

transmitting ultrasound waves toward a second portion of the subject and receiving second reflected ultrasound waves from the second portion such that the second portion of the subject is smaller than the first portion and includes at least some of the region of fluid flow identified by a processor (74) upon analyzing the first values;
 generating a second set of signals having second values related to fluid flow in said second portion of the subject in response to the second reflected ultrasound waves;
 processing the second scan values to generate processed color flow data for display as a color flow image; and
 displaying a color flow image in response to said processed color flow data.

7. A method, as claimed in claim 6, wherein said generating a second set of signals comprises gener-

ating multiple second sets of signals for each generating of said first sets of signals.

8. A method, as claimed in claim 6 or 7, wherein said first portion is divided into a plurality of subportions and wherein said second portion includes the subportions containing any of said region of fluid flow.
9. A method, as claimed in claim 6, 7 or 8, wherein said second portion includes the region of fluid flow and a buffer region adjacent said region of fluid flow.
10. A method, as claimed in any one of claims 6 to 9, wherein said processing comprises processing the second scan values to identify second flow data representing a region of fluid flow within the second portion of the subject and processing with adaptive color flow processing only the second flow data, so that the color flow data represents only the region of fluid flow within the second portion of the subject.

Patentansprüche

1. Vorrichtung zur Anwendung in einem Ultraschall-Bildgebungssystem (10) zum Anzeigen eines Farb-Strömungsbildes, das wenigstens einen Abschnitt eines untersuchten Patienten darstellt, wobei die Vorrichtung in Kombination aufweist:

eine Wandleranordnung (20), die als Reaktion auf einen ersten Befehl zum Aussenden von Ultraschallwellen auf einen ersten Abschnitt des Patienten und Empfangen erster reflektierter Ultraschallwellen aus dem ersten Abschnitt betrieben werden kann, und als Reaktion auf einen zweiten Befehl zum Aussenden von Ultraschallwellen auf einen zweiten Abschnitt des Patienten und Empfangen zweiter reflektierter Ultraschallwellen aus dem zweiten Abschnitt betrieben werden kann;

einen Prozessor (74), der zum Erzeugen des ersten Befehls geschaltet ist, um einen ersten Satz von Signalen mit auf eine Fluidströmung in den ersten Abschnitt des Patienten bezogenen ersten Werten als Reaktion auf die ersten reflektierten Ultraschallwellen zu erzeugen, und **dadurch gekennzeichnet, dass** er die ersten Werte analysiert, um Strömungsdaten zu identifizieren, die einen Bereich einer Fluidströmung in dem ersten Abschnitt des Patienten repräsentieren, um den zweiten Befehl so zu erzeugen, dass der zweite Abschnitt des Patienten kleiner als der erste Abschnitt ist, und wenigstens etwas von dem Bereich der von dem Prozessor (74) bei dem Analysieren der ersten Werte identifizierten Fluidströmung enthält, um einen zweiten Satz von Signalen mit auf die Fluidströmung in

- dem zweiten Abschnitt des Patienten bezogenen zweiten Werten als Reaktion auf die zweiten reflektierten Ultraschallwellen zu erzeugen und die zweiten Werte zu bearbeiten, um verarbeitete Farb-Strömungsdaten zur Anzeige als ein Farb-Strömungsbild zu erzeugen; und eine Anzeigeeinrichtung (230), die ein Farb-Strömungsbild Reaktion auf die verarbeiteten Farb-Strömungsdaten anzeigt.
2. Vorrichtung nach Anspruch 1, wobei der Prozessor (74) mehrere zweite Befehle für jede Erzeugung des ersten Befehls erzeugt.
3. Vorrichtung nach Anspruch 1 oder 2, wobei der erste Abschnitt in mehrere Unterabschnitte unterteilt ist und wobei der Prozessor den zweiten Befehl so erzeugt, dass der zweite Abschnitt die Unterabschnitte umfaßt, die etwas von dem Bereich der Fluidströmung enthalten.
4. Vorrichtung nach Anspruch 1, 2 oder 3, wobei der zweite Abschnitt den Bereich der Fluidströmung und einen an dem Bereich der Fluidströmung angrenzenden Pufferbereich umfaßt.
5. Vorrichtung nach einem der der vorstehenden Ansprüche, wobei der Prozessor (74) die zweiten Werte analysiert, um einen Bereich der Fluidströmung in dem zweiten Abschnitt des Patienten repräsentierenden zweite Strömungsdaten zu identifizieren, und mit adaptiver Farb-Strömungs-Verarbeitung nur die zweiten Strömungsdaten verarbeitet, so dass die Farb-Strömungsdaten nur den Bereich der Fluidströmung in dem zweiten Abschnitt des Patienten darstellen.
6. Verfahren zur Anwendung in einem Ultraschall-Bildgebungssystem (10) zum Anzeigen eines Farb-Strömungsbildes, das wenigstens einen Abschnitt eines untersuchten Patienten darstellt, wobei das Verfahren in Kombination die Schritte aufweist:
- Aussenden von Ultraschallwellen auf einen ersten Abschnitt des Patienten und Empfangen erster reflektierter Ultraschallwellen aus dem ersten Abschnitt;
- Erzeugen eines ersten Satzes von Signalen mit auf die Fluidströmung in dem ersten Abschnitt des Patienten bezogenen ersten Werten als Reaktion auf die ersten reflektierten Ultraschallwellen;
- Analysieren der ersten Werte, um einen Bereich von eine Fluidströmung in dem ersten Abschnitt des Patienten repräsentierende Strömungsdaten zu identifizieren;
- Aussenden von Ultraschallwellen auf einen zweiten Abschnitt des Patienten und Empfangen zweiter reflektierter Ultraschallwellen aus dem zweiten Abschnitt so, dass der zweite Abschnitt des Patienten kleiner als der erste Abschnitt ist und wenigstens etwas von dem Bereich der von einem Prozessor (74) bei dem Analysieren der ersten Werte identifizierten Fluidströmung enthält;
- Erzeugen eines zweiten Satzes von Signalen mit auf die Fluidströmung in dem zweiten Abschnitt des Patienten bezogenen zweiten Werten als Reaktion auf die zweiten reflektierten Ultraschallwellen;
- Verarbeiten der zweiten Scanwerte, um verarbeitete Farb-Strömungsdaten zur Anzeige als ein Farb-Strömungsbild zu erzeugen; und Anzeigen eines Farb-Strömungsbildes als Reaktion auf die verarbeiteten Farb-Strömungsdaten.
7. Verfahren nach Anspruch 6, wobei das Erzeugen eines zweiten Satzes von Signalen das Erzeugen mehrerer zweiter Sätze von Signalen für jede Erzeugung erster Sätze von Signalen beinhaltet.
8. Verfahren nach Anspruch 6 oder 7, wobei der erste Abschnitt in mehrere Unterabschnitte unterteilt ist und wobei der zweite Abschnitt die Unterabschnitte umfaßt, die etwas von dem Bereich der Fluidströmung enthalten.
9. Verfahren nach Anspruch 6, 7 oder 8, wobei der zweite Abschnitt den Bereich der Fluidströmung und einen an dem Bereich der Fluidströmung angrenzenden Pufferbereich umfaßt.
10. Verfahren nach einem der der Ansprüche 6 bis 9, wobei die Verarbeitung die Verarbeitung der zweiten Scanwerte beinhaltet, um einen Bereich einer Fluidströmung in dem zweiten Abschnitt des Patienten darstellende zweite Strömungsdaten zu identifizieren und mit adaptiver Farb-Strömungs-Verarbeitung nur die zweiten Strömungsdaten zu verarbeiten, so dass die Farb-Strömungsdaten nur den Bereich der Fluidströmung in dem zweiten Abschnitt des Patienten darstellen.

Revendications

1. Dispositif à usage dans un système d'imagerie ultrasonore (10) pour afficher une image couleur de flux représentant au moins une portion d'un sujet étudié, le dispositif comprenant en combinaison:

un ensemble à transducteur (20) utilisable en réponse à une première instruction pour émettre

gekennzeichnet durch:

- des ondes ultrasonores vers une première portion du sujet et recevoir des premières ondes ultrasonores réfléchies provenant de la première portion, et utilisable en réponse à une deuxième instruction pour émettre des ondes ultrasonores vers une deuxième portion du sujet et recevoir des deuxièmes ondes ultrasonores réfléchies provenant de la deuxième portion;
- un processeur (74) connecté pour générer la première instruction, pour générer un premier ensemble de signaux ayant des premières valeurs liées à un écoulement de fluide dans ladite première portion du sujet en réponse aux premières ondes ultrasonores réfléchies, et **caractérisé en ce qu'il** est prévu pour analyser les premières valeurs afin d'identifier des données de flux représentant une région d'écoulement de fluide à l'intérieur de la première portion du sujet, pour générer ladite deuxième instruction de telle manière que la deuxième portion du sujet est plus petite que la première portion et inclut au moins une partie de la région d'écoulement de fluide identifiée par ledit processeur (74) par analyse des premières valeurs, pour générer un deuxième ensemble de signaux ayant des deuxièmes valeurs liées à un écoulement de fluide dans ladite deuxième portion du sujet en réponse aux deuxièmes ondes ultrasonores réfléchies, et pour traiter les deuxièmes valeurs afin de générer des données de flux couleur traitées en vue d'un affichage sous forme d'image couleur de flux; et
- un dispositif d'affichage (230) affichant une image couleur de flux en réponse aux dites données de flux couleur traitées.
2. Dispositif selon la revendication 1, dans lequel ledit processeur (74) génère de multiples deuxièmes instructions pour chaque génération de ladite première instruction.
 3. Dispositif selon la revendication 1 ou 2, dans lequel ladite première portion est divisée en une pluralité de sous-portions et dans lequel ledit processeur génère ladite deuxième instruction de telle manière que la deuxième portion inclut les sous-portions contenant une partie quelconque de ladite région d'écoulement de fluide.
 4. Dispositif selon la revendication 1, 2 ou 3, dans lequel ladite deuxième portion inclut la région d'écoulement de fluide et une région tampon adjacente à ladite région d'écoulement de fluide.
 5. Dispositif selon l'une quelconque des revendications précédentes, dans lequel ledit processeur (74) analyse les deuxièmes valeurs afin d'identifier des deuxièmes données de flux représentant une région d'écoulement de fluide à l'intérieur de la deuxième portion du sujet, et traite par un traitement de flux couleur adaptatif les seules deuxièmes données de flux, de sorte que les données de flux couleur représentent seulement la région d'écoulement de fluide à l'intérieur de la deuxième portion du sujet.
 6. Procédé à usage dans un système d'imagerie ultrasonore (10) pour afficher une image couleur de flux représentant au moins une portion d'un sujet étudié, le procédé comprenant en combinaison les étapes consistant à:
 - émettre des ondes ultrasonores vers une première portion du sujet et recevoir des premières ondes ultrasonores réfléchies provenant de la première portion;
 - générer un premier ensemble de signaux ayant des premières valeurs liées à un écoulement de fluide dans ladite première portion du sujet en réponse aux premières ondes ultrasonores réfléchies;
 - analyser les premières valeurs afin d'identifier des données de flux représentant une région d'écoulement de fluide à l'intérieur de la première portion du sujet, **caractérisé par** les étapes consistant à:
 - émettre des ondes ultrasonores vers une deuxième portion du sujet et recevoir des deuxièmes ondes ultrasonores réfléchies provenant de la deuxième portion de telle manière que la deuxième portion du sujet est plus petite que la première portion et inclut au moins une partie de la région d'écoulement de fluide identifiée par un processeur (74) par analyse des premières valeurs;
 - générer un deuxième ensemble de signaux ayant des deuxièmes valeurs liées à un écoulement de fluide dans ladite deuxième portion du sujet en réponse aux deuxièmes ondes ultrasonores réfléchies;
 - traiter les deuxièmes valeurs de balayage afin de générer des données de flux couleur traitées en vue d'un affichage sous forme d'image couleur de flux; et
 - afficher une image couleur de flux en réponse aux dites données de flux couleur traitées.
 7. Procédé selon la revendication 6, dans lequel ladite génération d'un deuxième ensemble de signaux comprend le fait de générer de multiples deuxièmes ensembles de signaux pour chaque génération dudit premier ensemble de signaux.
 8. Procédé selon la revendication 6 ou 7, dans lequel

ladite première portion est divisée en une pluralité de sous-portions et dans lequel ladite deuxième portion inclut les sous-portions contenant une partie quelconque de ladite région d'écoulement de fluide.

5

9. Procédé selon la revendication 6, 7 ou 8, dans lequel ladite deuxième portion inclut la région d'écoulement de fluide et une région tampon adjacente à ladite région d'écoulement de fluide.

10

10. Procédé selon l'une quelconque des revendications 6 à 9, dans lequel ledit traitement comprend le fait de traiter les deuxièmes valeurs de balayage afin d'identifier des deuxièmes données de flux représentant une région d'écoulement de fluide à l'intérieur de la deuxième portion du sujet et de traiter par un traitement de flux couleur adaptatif les seules deuxièmes données de flux, de sorte que les données de flux couleur représentent seulement la région d'écoulement de fluide à l'intérieur de la deuxième portion du sujet.

15

20

25

30

35

40

45

50

55

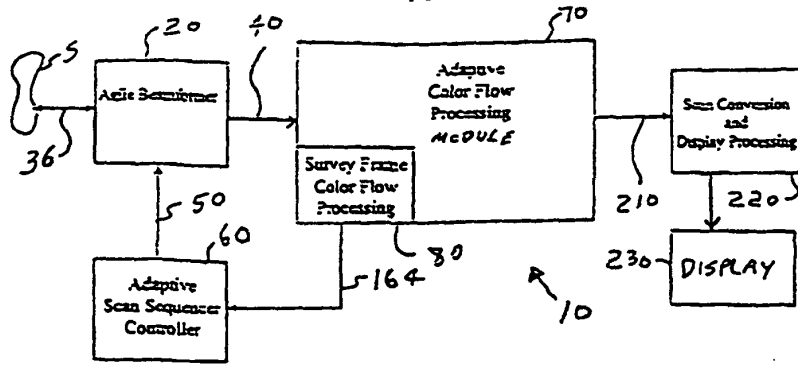

FIG. 1

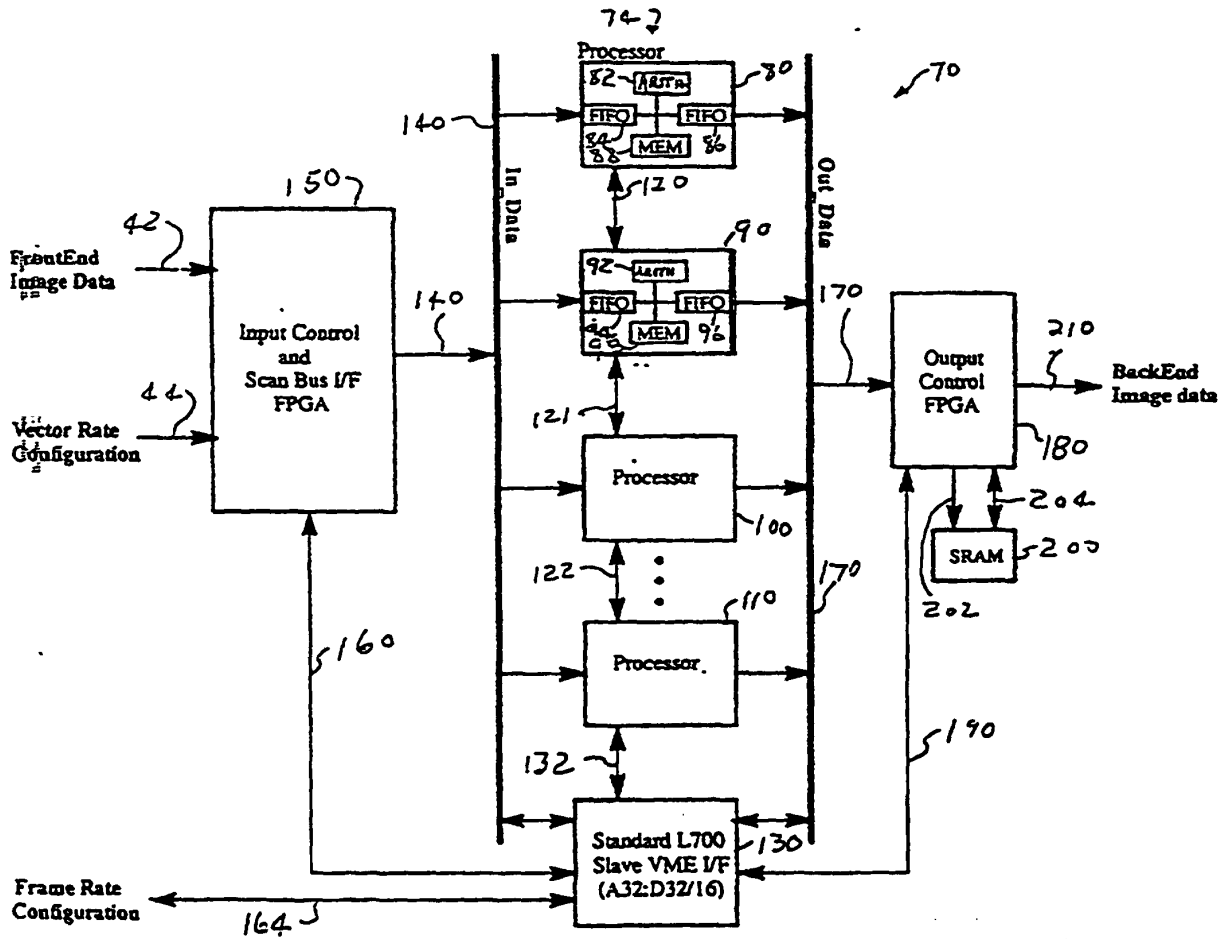

FIG. 2

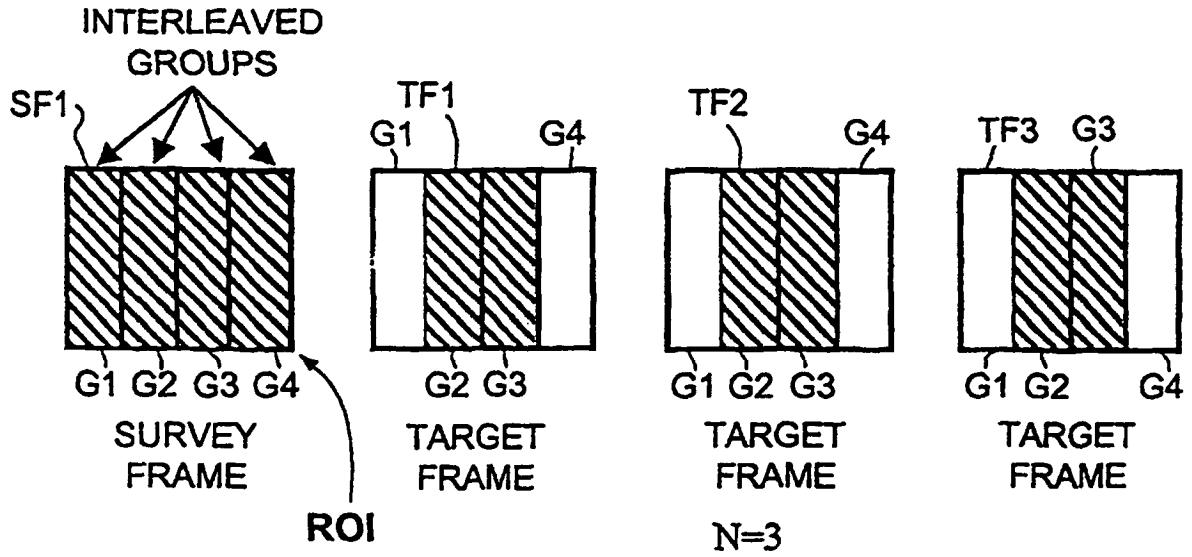

Fig. 3

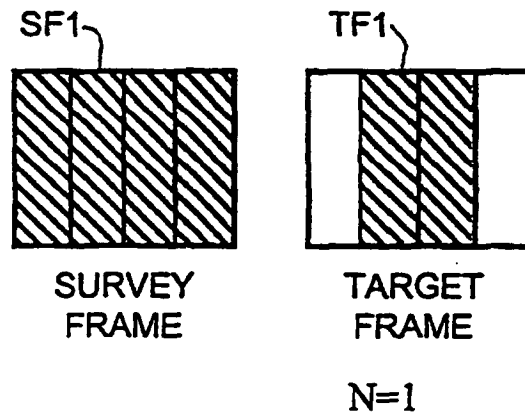

Fig. 4

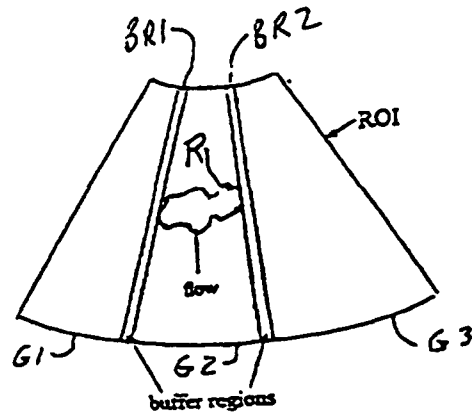

FIG. 5

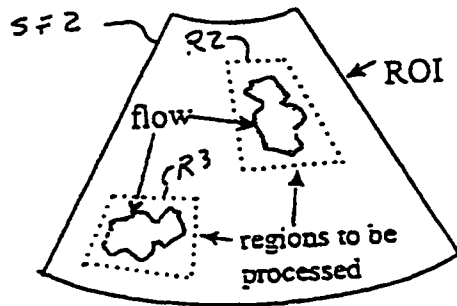

FIG. 6

专利名称(译)	超声彩色血流自适应扫描技术		
公开(公告)号	EP1111404B1	公开(公告)日	2006-03-29
申请号	EP2000311498	申请日	2000-12-20
[标]申请(专利权)人(译)	通用电气公司		
申请(专利权)人(译)	通用电气公司		
当前申请(专利权)人(译)	通用电气公司		
[标]发明人	MUZILLA DAVID JOHN RHYNE THEODORE LAUER		
发明人	MUZILLA, DAVID JOHN RHYNE, THEODORE LAUER		
IPC分类号	G01S15/89 G01S7/52 A61B8/06 A61B8/14 G06T1/00		
CPC分类号	G01S15/8979 G01S7/52023		
优先权	09/468181 1999-12-21 US		
其他公开文献	EP1111404A2 EP1111404A3		
外部链接	Espacenet		

摘要(译)

处理超声波测量框架 (SF) 以确定表示流体流动的部分。组件 (20) 再次仅重新扫描由测量框架中发现流体流动的部分所代表的对象部分。然后从重新扫描创建目标帧 (TF) 并对其进行处理，以便提供限制于指示流体流动的测量框架部分的彩色流图像。

