

(19)



(11)

EP 1 825 814 B1

(12)

EUROPEAN PATENT SPECIFICATION

(45) Date of publication and mention of the grant of the patent:
20.02.2013 Bulletin 2013/08

(51) Int Cl.:
A61B 8/00 (2006.01)

(21) Application number: **05814385.0**

(86) International application number:
PCT/JP2005/022564

(22) Date of filing: **08.12.2005**

(87) International publication number:
WO 2006/062164 (15.06.2006 Gazette 2006/24)

(54) **ULTRASONIC PROBE**

ULTRASCHALLSONDE

SONDE ULTRASONORE

(84) Designated Contracting States:
DE FR GB IT NL

(72) Inventor: **HU, Zhiqiang**
2770803 (JP)

(30) Priority: **09.12.2004 JP 2004356971**

(74) Representative: **Strehl Schübel-Hopf & Partner**
Maximilianstrasse 54
80538 München (DE)

(43) Date of publication of application:
29.08.2007 Bulletin 2007/35

(73) Proprietor: **Hitachi Medical Corporation**
Tokyo (JP)

(56) References cited:
EP-A2- 0 727 259 JP-A- 1 293 851
JP-A- 5 244 690 JP-A- 09 010 216
JP-A- 61 268 238 JP-U- 02 061 312
US-A- 6 051 913 US-B1- 6 467 138

EP 1 825 814 B1

Note: Within nine months of the publication of the mention of the grant of the European patent in the European Patent Bulletin, any person may give notice to the European Patent Office of opposition to that patent, in accordance with the Implementing Regulations. Notice of opposition shall not be deemed to have been filed until the opposition fee has been paid. (Art. 99(1) European Patent Convention).

Description

Technical Field

5 **[0001]** The present invention relates to an ultrasonic probe in which transducers are arranged for transmitting and receiving ultrasonic waves between an object to be examined, and an ultrasonic diagnostic apparatus for constructing an ultrasonic image as a diagnostic image of the object.

Background Art

10 **[0002]** An ultrasonic diagnostic apparatus is for providing driving signals to an ultrasonic probe, and for reconstructing an ultrasonic image based on the receiving signal outputted from the ultrasonic probe. An ultrasonic probe is for converting the driving signals into ultrasonic waves and transmitting them to the object, and has transducers arranged therein which are for receiving the reflected echo signals generated from the object and converting them into the receiving signals.

15 **[0003]** In an ultrasonic probe, upon transmitting ultrasonic waves from the transducers to the object, ultrasonic waves are effused also to the backside of the probe. Given this factor, a backside section is disposed on the backside of the transducer. For example, the backside section has a backing layer disposed on the backside of the transducer and a heat-dissipating member laminated on the backside of the backing layer, causes the backing layer to attenuate the ultrasonic waves effused to the backside of the transducer, and discharges the heat built up in the backing layer due to the attenuation to the outside via the heat-dissipating member (for example, refer to Patent Document 1).

20 However, there are cases that the incoming ultrasonic waves from the transducer to the backside return to the transducer side by reflecting at the backside, especially at the bonded surface of the backing layer and the heat-dissipating member. Such reflected waves could lead to deterioration of S/N (Signal to Noise) of ultrasonic images, and also to increase of surface temperature of the ultrasonic probe.

25 Given this factor, in Patent Document 1, reduction of noise is carried out by changing figuration of the bonded surface of the backing layer and the heat-dissipating member to the minor axis direction of the transducer, and dispersing the reflected waves being reflected at the bonded surface and returned to the transducer side.

[0004]

30 Patent Document 1: JP-A-2004-329495

EP 0 727 259 A2 discloses an ultrasonic transducer with the features in the pre-characterizing portion of claim 1. A similar transducer is further disclosed in US 6 051 913 A. Another related transducer is described in JP 01 293851 A. JP 1-293851 discloses an ultrasonic probe according to the preamble of claim 1.

35 Disclosure of the Invention

Problems to be Solved

40 **[0005]** However, in the method for changing the bonded surface of the backing layer and the heat-dissipating member in the minor axis direction of the transducer described in Patent Document 1, the possibility remains that a part of the dispersed reflected waves return to the transducer side, and as for the reduction of the reflected waves, there still remains room for further improvement.

45 **[0006]** Or, in a method as seen in Patent Document 1, another possibility for sufficiently attenuating ultrasonic waves effused from the transducer to the heat-dissipating member is to make the backing layer thicker. However, whereas the ultrasonic waves can be attenuated using the backing layer, thermal resistance increases in proportion to the thickness of the backing layer whereby increasing heat storage therein. As a result, the heat stored in the backing layer can easily be carried to the transducer side, which lowers sensitivity of the ultrasonic probe and leads to the increase of surface temperature, thus thickening of the backing layer is not preferable.

50 **[0007]** The objective of the present invention is to provide an ultrasonic probe that effectively reduces the reflected waves returning from the backside of the probe to the transducer side.

Means to Solve the Problem

55 **[0008]** In order to achieve the above-mentioned objective, the ultrasonic probe of the present invention is defined as in claim 1. Also, in order to solve the above-mentioned problems, the ultrasonic diagnostic apparatus of the present invention is characterized in comprising the ultrasonic probe as mentioned above. Further advantageous features of the invention are set out in the dependent claims.

[0009] By such configuration, ultrasonic waves effused from the transducer to the backside are attenuated in the first attenuation section, and receives further attenuation in the second attenuation section, whereby attenuating a majority of the incoming ultrasonic waves to the backside. Through this effect, the reflected waves returning from the backside of the probe to the transducer side can be effectively reduced.

[0010] Particularly, when the backing layer as the first attenuation section being disposed on the backside of the transducer and the heat-dissipating section disposed on the backside of the backing section are provided as the backside section, the second attenuation section is formed in the backing layer and the heat-dissipating section.

By such configuration, a majority of incoming ultrasonic waves on the backing layer and the second attenuation section are attenuated, and both effects for restraining increase of temperature of the probe on the body surface of the object and lowering the reflected waves being the base of noise can be attained, even when thickness of the backing layer is reduced.

[0011] Also, when the second attenuation section is formed in the backing layer being the first attenuation section, it is desirable that the second attenuation section is formed so that the position of the end surface of the second attenuation section on the transducer side falls on the position apart from the surface on the transducer side of the backing layer by an integral multiplication of the wavelength of the ultrasonic wave in vertical direction to the backside of the transducer. Or, when the second attenuation section is formed in the heat-dissipating section, it is desirable that the second attenuation section is formed so that the position of the end surface of the second attenuation section on the transducer side falls on the position apart from the bonded surface of the backing layer and the heat-dissipating section by an integral multiplication of the wavelength of the ultrasonic wave in vertical direction to the backside of the transducer. By such formation of the second attenuation section, acoustic impedance equivalent to thickness of an integral multiplication of the wavelength of the ultrasonic wave can be made approximately zero, and the reflected waves returning from the backside section to the transducer side can be further constrained.

The second attenuation section is formed having a void, and the void is filled in with a sound absorbing material. By such configuration, effect for attenuating noise that appears on an ultrasound image can be further improved.

[0012] As mentioned above, the present invention can provide an ultrasonic probe having improved effect on reducing the reflected waves returning from the backside to the transducer side, and an ultrasonic diagnostic apparatus having improved effect on reducing noise appearing on an ultrasound image.

Best Mode for Carrying Out the Invention

(The first embodiment)

[0013] The first embodiment of the ultrasonic probe to which the present invention is applied will be described referring to the diagrams. Fig. 1A is a diagram showing a cross section in axis direction of the ultrasonic probe of the present embodiment, viewing from major axis direction. Fig. 1B is a diagram showing a heat-dissipating block of Fig. 1A viewing from major axis direction (direction of arrow X shown in the diagram).

[0014] As shown in Fig. 1A and Fig. 1B, ultrasonic probe 1 to use for imaging an ultrasound image of the object comprises transducer 10 for transmitting/receiving ultrasonic waves between the object and the backside section imposed on the backside of the transducer. The backside section has backing material 12 as the backing layer (the first attenuation section) imposed on the backside of transducer 10 and heat-dissipating block 14 as the heat-dissipating section laminated on the backside of backing material 12. Ultrasonic probe 1 is stored in the probe case.

[0015] Ultrasonic probe 1 has void 16 formed in heat-dissipating block 14 as the second attenuation section as shown in Fig. 1B, and sound absorbing material (that is the material for absorbing and attenuating ultrasonic waves) 18 is filled in void 16. Heat-dissipating block 14 is formed with a material having high thermal conductivity (for example, a metal such as aluminum). As for the material for sound absorbing material 18, natural material or synthetic material having comparatively large rate of decrease such as silicon or epoxide resin is used.

[0016] Further, ultrasonic probe 1 will be described. Transducer 10 has a plurality of piezoelectric elements being arranged therein for transmitting/receiving ultrasonic waves between the object. For the sake of convenience, the array direction of the piezoelectric elements will be referred to as major axis direction, and direction orthogonal to major axis direction will be referred to as minor axis direction. Also, the side of the surface of transducer 10 for transmitting/receiving ultrasonic waves will be arbitrarily referred to as an object side, and the opposite surface side thereof will be referred to as the back surface side.

[0017] On the object side of transducer 10, acoustic commensurate layer 22 is laminated intervening electrode 20a in between. Acoustic lens 24 is disposed on the object side of acoustic commensurate layer 22. Acoustic commensurate layer 22 is formed with material having acoustic impedance of, for example, in the middle of transducer 10 and the object, and effectively transmits ultrasonic waves transmitted from transducer 10 into the object. Acoustic lens 24 has a convex surface for focusing ultrasonic waves.

[0018] Meanwhile, backing material 12 is disposed on the backside of transducer 10 intervening electrode 20b in

between. Backing material 12 is for absorbing ultrasonic waves transmitted from transducer 10 to the backside. Heat-dissipating block 14 has bonded section 14a being bonded to the backside of backing material 12 and extended section 14b which is a board shape and is extended from bonded section 14a in backside direction (direction of arrow Y in the diagram). Bonded section 14a is formed so that the cross-sectional area of the side connecting to extended section 14b in minor axis direction is being reduced as proceeding toward extended section 14b. In other words, the backside of bonded section 14a on the side connecting to extended section 14b is slanted in minor axis direction. Extended section 14b is formed so that the width in minor direction becomes smaller than bonded section 14a and that the width in major direction becomes the same as bonded section 14a, corresponding to the gripper of the probe case.

[0019] In heat-dissipating block 14, void 16 is formed inside of extended section 14b. Void 16 is formed in the position apart from the surface on the side of transducer 10 of heat-dissipating block 14 (that is the bonded surface of backing material 12 and heat-dissipating block 14) by integer n-times of the wavelength λ of the ultrasonic wave, in the thickness direction (direction of arrow Y in the diagram). In this case, as will be described later, acoustic impedance of the part equivalent to the thickness can be made approximately zero, and the reflected waves returning from the backside to the transducer side can be constrained more effectively.

As for the method for forming void 16, cutting work such as drilling can be applied. Formed void 16 passes through extended section 14b in minor direction, and is zoned into two flat surfaces parallel to minor axis direction and the rounded surface connecting the respective surfaces thereof. Meantime, void 16 can be formed at a part in minor axis direction without passing through in minor axis direction. Distance S between the flat surface which zones void 16 and the sidewall of heat-dissipating block 14 is designed as, for example, 7mm. Also, rounded surface 26 of void 16 on the side closer to backing material 12 has the bending radius of, for example, 8mm and is distended to the side of transducer 10. The rounded surface on the side farther from backing material 12 has the bending radius of, for example, 8mm and is distended in backside direction (direction of arrow Y in the diagram). And length in backside direction of void 16 is designed as, for example, 20mm. Void 16 may be formed plurally by arranging them in major or minor directions. Also, void 16 can be formed in bonded section 14a of heat-dissipating section 14 by making integer-n a small number. Or, on the contrary, void 16 may be formed at the back of extended section 14b of heat-dissipating block 14 by making integer-n a big number.

[0020] Void 16 of the present embodiment is filled with sound absorbing material 18. As for the material of sound absorbing material 18, while natural material or synthetic material such as silicon or epoxide resin having comparatively large rate of decrease may be used, it is preferable to use the material having approximately the same acoustic impedance as the one of backing material 12.

[0021] When drive signals are provided to such configured ultrasonic probe 1., the provided drive signals are applied to transducer 10 via electrodes 20a and 20b. The applied drive signals are converted into ultrasonic waves by transducer 10 and transmitted to the object. The reflected echo generated from the object is received by transducer 10. The received reflected echo is converted into a reception signal as an electronic signal, and outputted from the ultrasonic probe. An ultrasound image is thus constructed by the ultrasonic diagnosis apparatus based on the outputted reception signals.

[0022] In such ultrasonic probe 1, when ultrasonic waves are transmitted to the object from transducer 10, the ultrasonic waves are effused also on the backside of transducer 10. Most of the effused ultrasonic waves are attenuated at backing material 12. The ultrasonic waves passed through backing material 12 without being attenuated enter in heat-dissipating block 14.

[0023] In accordance with the present embodiment, since difference between acoustic impedance of sound absorbing material 18 and acoustic impedance of heat-dissipating block 14 is comparatively small, most of the incoming ultrasonic waves to heat-dissipating block 14 enter into sound absorbing material 18 and get attenuated. Accordingly, reflected waves returning from heat-dissipating block 14 to transducer 10 side can be reduced.

[0024] In particular, according to the present embodiment, it is possible to reduce the reflected waves returning from heat-dissipating block 14 without increasing the thickness of backing material 12, that is, with the usage of thin backing material 12. Therefore, the effect for both restraining increase of surface temperature of acoustic lens 24 and reducing the reflected waves causing noise can be attained. As a result, since energy of drive signals to be provided to transducer 10 can be increased, ultrasonic waves can be emitted to comparatively deep portions of the object, and image quality of the ultrasound images can be improved.

[0025] Also, as to heat-dissipating block 14, since thickness L from the surface on the side of transducer 10 (that is the bonded surface of backing material 12 and heat-dissipating block 14) to void 16 is integer n-times of the wavelength λ of ultrasonic waves, acoustic impedance of the part equivalent to the thickness becomes zero. Therefore, noise due to the reflected waves returning from heat-dissipating block 14 can be restrained.

[0026] Also, as seen in Fig. 1A and Fig. 1B, even when void 16 is formed, the contact area of heat-dissipating block 14 and backing material 12 does not change, and heat transmits from backing material 12 to heat-dissipating block 14 via contact surface thereof. The transmitted heat runs through the portions such as between the sidewall of heat-dissipating block 14 and the flat surface of void 16, then is discharged to the outside from the surface of heat-dissipating block 14. Since the communication channel of heat is secured in this way, it is possible to avoid degradation of discharge

characteristics of heat-dissipating block 14, whereby restraining the increase of surface temperature of acoustic lens 24.

[0027] Fig. 2 is a block diagram of ultrasonic diagnostic apparatus 2 to which ultrasonic probe 1 is connected. Ultrasonic diagnostic apparatus 2 comprises:

- 5 transmission/reception unit 30 for providing drive signals to ultrasonic probe 1 and processing the reception signals outputted from ultrasonic probe 1;
 phasing addition unit 32 for phasing and adding the reception signals outputted from transmission/reception unit 30;
 image constructing unit 34 for reconstructing an ultrasound image based on the reception signals outputted from the phasing addition unit 32; and
 10 display unit 36 for displaying an ultrasound image outputted from image constructing unit 34.

[0028] Fig. 3 is a display example for verifying the effect of the present embodiment. For the sake of convenience, the diagram is illustrated with a focus on the noise appears on the ultrasound image. Fig. 3A is a display example upon imaging a heart. As seen in Fig. 3A, ultrasound image 39 and ultrasound image 41 are displayed side by side. Ultrasound image 39 is an image created using a prior and existing ultrasonic probe. Ultrasound image 41 is an image created using ultrasonic probe 1 of the present embodiment. Also, in the present example, silicon with 0.81dB/mm of rate of decrease is used. As seen in Fig. 3A, noise is effectively reduced in ultrasound image 41 compared to ultrasound image 39. Also, it was verified that the surface temperature of acoustic lens 24 was not increased even after 2.5 hours passed since the start time of imaging.

20 **[0029]** Fig. 3B is a display example upon imaging a skull bone. Ultrasound image 43 being imaged using the prior and existing ultrasonic probe is displayed on the left side, and ultrasound image 45 being imaged using ultrasonic probe 1 of the present embodiment is displayed on the right side. In the same manner as Fig. 3A, noise is effectively reduced in ultrasound image 45 compared to ultrasound image 43.

25 **[0030]** Furthermore, as for sound absorbing material 18, the same result could be obtained with the usage of epoxy (trade name: Epicoat 807, manufacturer: Yuka-Shell Epoxy Co., Ltd.), tungsten (trade name: W-2, manufacturer: Japan New Metals Co., Ltd.), admixture of epoxy and tungsten (mixing ratio 16g:57g, rate of decrease 1.13dB), and Achmex (trade name: Achmex R-11, manufacturer: Nihon Gosei Kako Co., Ltd., rate of decrease: 2.94dB/mm). Rate of decrease mentioned here indicates the rate that ultrasonic waves of 2MHz frequency in a circumstance of normal temperature 25° C decreases. Epicoat and Achmex mentioned here are registered trademarks.

30 **[0031]** While an example of disposing backing material 12 and heat-dissipating block 14 as the backside section is described, only one of the two may be disposed. In that case, void 16 can be formed in either backing material 12 or heat-dissipating block 14, and sound absorbing material 18 can be filled in the void 16.

35 **[0032]** As mentioned above, in accordance with the present embodiment, the reflected waves returning from heat-dissipating block 14 to transducer 10 side can be restrained and S/N of images can be improved, by forming void 16 of predetermined size at a predetermined distance from the surface of backing material 12 side of heat-dissipating block 14 and filling sound absorbing material 18 in the void 16. Furthermore, since thickness of backing material 12 can be made small, degradation of transmitting/receiving sensitivity of transducer 10 can be reduced and increase of surface temperature of acoustic lens 24 can be restrained.

40 **[0033]** Here, additional description will be made regarding position of void 16. Fig. 4 is a diagram for illustrating position of the void, and is for use in acoustic analysis of 4 terminal networks to be used for electric circuit analysis.

45 **[0034]** As seen in Fig. 4, backing material 46 is connected to the terminal I side of heat-dissipating section 47 via a pair of end terminals. In heat-dissipating block section 47, the side of terminal II is connected to sound absorbing material section 48 via a pair of end terminals. A, B, C and D in the diagram are comparable to 4 terminal constant of the electric network theory. Z_B denotes acoustic impedance of backing material section 46. Z_r denotes acoustic impedance of heat-dissipating block section 47. Z_x denotes acoustic impedance of the sound absorbing material. E_1 and E_2 are comparable to power voltage of the electric network theory, and I_1 and I_2 are comparable to electric current.

50 **[0035]** In such 4 terminal network, impedance Z_{11} can be represented as formula 1. Also, in the case that a material of which the rate of decrease is small is used for heat-dissipating block section 47, formula 1 is expressed as formula 2. Here, λ is the wavelength of the incoming ultrasonic wave to heat-dissipating block section 47. L is thickness of heat-dissipating block section 47 intervened between backing material section 46 and sound absorbing material section 48, which is comparable to the distance, in case of Fig. 1, from the surface on the transducer 10 side of heat-dissipating block 14 to void 16 in the thickness direction.

[0036]

[Formula 1]

$$Z_{i1} = \frac{E_1}{I_1} = (AZ_x + B)/(CZ_x + D)$$

[Formula 2]

$$Z_{i1} = \frac{\cos \frac{2\pi}{\lambda} L \cdot Z_x + Z_r j \sin \frac{2\pi}{\lambda} L}{(Z_x / Z_r) j \sin \frac{2\pi}{\lambda} L + \cos \frac{2\pi}{\lambda} L}$$

[0037] In the same manner, impedance Z_{i2} of heat dissipating block section 47, viewing from terminal II side is expressed as formula 3. Also, in the case of using a material having a small rate of decrease for heat-dissipating block section 47, formula 3 is expressed as formula 4.

[0038]

[Formula 3]

$$Z_{i2} = \frac{E_2}{I_2} = (DZ_B + B)/(CZ_B + A)$$

[Formula 4]

$$Z_{i2} = \frac{\cos \frac{2\pi}{\lambda} L \cdot Z_B + Z_r j \sin \frac{2\pi}{\lambda} L}{-(Z_B / Z_r) j \sin \frac{2\pi}{\lambda} L + \cos \frac{2\pi}{\lambda} L}$$

[0039] When $L = \lambda$ in formula 2 and formula 3, impedance Z_{i1} is expressed as formula 5. Also, impedance Z_{i2} is expressed as formula 6.

[0040]

[Formula 5]

$$Z_{i1} = Z_x$$

[Formula 6]

$$Z_{i2} = Z_B$$

[0041] As evidenced by formulas 5 and 6, when $L = n\lambda$, from backing material section 46, impedance of heat-dissipating block section 47 turns out to be the same as impedance Z_x of sound absorbing material section 48. In the same manner, from sound absorbing material section 48, impedance of heat-dissipating block section 47 turns out to be the same as impedance Z_B of backing material section 46. In other words, when thickness L from the surface on transducer 10 side of heat-dissipating block 14 in Fig. 1 to void 16 in the thickness direction is integer n -times of the wavelength λ of the ultrasonic wave, acoustic impedance of the part equivalent to the thickness L looks as zero, thus noise due to reflected waves returning from heat-dissipating block 14 can be reduced. Especially, when $Z_x = Z_B$, since difference between acoustic impedance on terminal I side of heat-dissipating block section 47 and acoustic impedance on terminal II side becomes zero, noise due to reflected waves can be reduced even more efficiently.

(Second embodiment)

[0042] A second embodiment of the ultrasonic probe to which the present invention is applied will be described referring to Fig. 5. The present embodiment is different, in the point of using a triple layered heat-dissipating section, from the first embodiment using the heat-dissipating block in which the void is formed. Therefore, points of difference will be mainly described, by using the same symbols for the places relatively corresponding to the first embodiment.

[0043] Fig. 5 is a diagram showing a cross section in axis direction of ultrasonic probe of the present embodiment 1b, viewing from minor axis direction. As shown in Fig. 5, in ultrasonic probe 1b, a triple layered heat-dissipating section is disposed in the backside of backing material 12. The heat-dissipating section has heat-dissipating member 51 as the first heat-dissipating layer disposed on the backside of backing material 12, sound absorbing material 52 as the sound-absorbing layer laminated on the backside of heat-dissipating member 51, and heat-dissipating member 53 as the second heat-dissipating layer laminated on the backside of sound absorbing material 52. In other words, sound absorbing material 52 is sandwiched between heat-dissipating member 51 and heat-dissipating member 53. Heat-dissipating member 53 is formed having larger volume than heat-dissipating member 51. Also, material for heat-dissipating member 51 and heat-dissipating member 53 is the same as heat-dissipating block 14 of the first embodiment, which is a metal such as aluminum.

[0044] Also, support member 54 being extended along the sidewall of heat-dissipating member is disposed. One end side of support member 54 is fixed on the sidewall of heat-dissipating member 51 by a part such as a tuning peg, and other end side is fixed on the sidewall of heat-dissipating member 53 by a part such as a tuning peg. In other words, support member 54 is placed from heat-dissipating member 51 to heat-dissipating material 53 via sound absorbing material 52 along the sidewall. Support member 54 is formed by a material having heat transfer property such as aluminum, and operates as heat transfer channel. While two support members 54 are disposed in the example of Fig. 5, they can be increased as the need arises.

[0045] Thickness T_a of heat-dissipating member 51 needs to be an integral multiplication of the wavelength of the ultrasonic wave, and it is formed as, for example, 3.4mm being the same as the wavelength of the ultrasonic wave in the example of Fig. 5. The ultrasonic wave mentioned here is the ultrasonic wave incoming to heat-dissipating member 51. For example, when center frequency of the incoming ultrasonic wave is 2MHz and acoustic velocity at heat-dissipating member 51 is 6800m/sec, 1 wavelength of the ultrasonic wave would be 3.4mm. Also, in sound absorbing material 52, while thickness T_b is formed as, for example, 5mm, it can be determined as need arises.

[0046] In accordance with the present embodiment, since thickness T_a is small being the same as the wavelength of the ultrasonic wave, the ultrasonic wave incoming to heat-dissipating member 51 reaches sound absorbing material 52

passing through heat-dissipating member 51. Because of the above-mentioned effect, since the majority of ultrasonic waves are attenuated in sound absorbing member 52, the reflected waves returning from heat-dissipating member 51 to backing material 12 side are restrained and multiple noises can be reduced.

[0047] Also, the heat accumulated in heat-dissipating member 51 is conducted to heat-dissipating member 53 via support member 54. The conducted heat is effectively discharged to outside via support member 54, whereby restraining increase of surface temperature of acoustic lens 24.

(The third embodiment)

[0048] The third embodiment of the ultrasonic probe to which the present invention is applied will be described referring to Fig. 6. The present embodiment has the position and size of the void that are different from the first embodiment. Therefore, points of difference will be mainly described, by using the same symbols for the places relatively corresponding to the first embodiment.

[0049] Fig. 6 is a diagram showing a cross section in axis direction of ultrasonic probe 1c of the present invention, viewing from major axis direction. As shown in Fig. 6, in ultrasonic probe 1c, void 60 is formed in bonded section 14a of heat-dissipating block 14. Void 60 passes through bonded section 14a in major axis direction, and is zoned by two flat surfaces parallel to the backside of backing material 12 and a rounded surface connecting the respective flat surfaces. Void 60 also may be formed in a part of major axis direction without passing through in major axis direction. Distance U_a between the flat surfaces are designed as, for example, 5mm. The rounded surface has bending radius of, for example, 2.5mm and is distended to the wall side of bonded section 14a. In such void 60, sound absorbing material 62 is filled in. As for the material for sound absorbing material 62, it is the same as the one in the first embodiment.

[0050] Thickness U_b from the backside of backing material 12 (that is the bonded surface of backing material 12 and bonded section 14a) to the upper surface of void 60 (the end surface of the transducer side) needs to be an integral multiple of the wavelength of the ultrasonic wave, and is designed as, for example, 3.4mm being the same as the wavelength of the ultrasonic wave, in the example of Fig. 6. Also, minimum thickness U_c from the rounded surface of void 60 to the sidewall of bonded section 14a is designed as, for example, 1mm.

[0051] In accordance with the present embodiment, since thickness U_b is small being the same as the wavelength of the ultrasonic wave, the ultrasonic waves incoming from backing material 12 to bonded section 14a are mostly attenuated in sound absorbing material 62 of void 60 by passing through the part equivalent to thickness U_b . By this effect, the ultrasonic waves returning from heat-dissipating block 14 to the side of backing material 12 can be attenuated and multiple noises can be reduced.

[0052] Also, when heat of backing material 12 is transmitted to heat-dissipating block 14, the transmitted heat is conducted to the side of extended section 14b via places such as a part equivalent to thickness U_c . Since extended section 14b is formed having comparatively large area, heat can be effectively discharged to the outside from the surface area of extended section 14b. In other words, the part equivalent to thickness U_c operates as a heat transfer-channel, there is no need for disposing other members, whereby by simplifying the configuration of ultrasonic probe 1c.

[0053] Fig. 7 is a diagram showing a cross section in axis direction of ultrasonic probe 1d of another example of the present embodiment, viewing from minor axis direction. As seen in Fig. 7, a different point of ultrasonic probe 1d from the example in Fig. 6 is that void 70 passing through bonded section 14a in minor direction is formed in place of void 60 passing through bonded section 14a in major direction. Void 70 may be formed in a part in minor direction without passing through in minor direction. By such formation, the same - effect as the example in Fig. 6 can be obtained.

[0054] Fig. 8A is a diagram showing the cross section in axis direction of ultrasonic probe 1e of another example of the present embodiment, viewing from major direction. Fig. 8B is a diagram viewing heat-dissipating block 14 of Fig. 8A from minor direction (direction of arrow X in the diagram).

As shown in Fig. 8, a different point of ultrasonic probe 1e from the example in Fig. 6 is that void 72 passing through bonded section 14a in minor direction is formed, in addition to void 60 passing through bonded section 14a in major axis direction. In other words, void 60 and void 72 are formed being orthogonal to each other. As shown in Fig. 8B, void 72 is designed with width W in major direction being, for example, 10mm. According to the present embodiment, ultrasonic waves returning from heat-dissipating block 14 to the side of backing material 12 can be restrained more effectively:

[0055] While the present invention has been described through the third embodiment, it should not be taken in way of limitation. For example, shape of the bonded surface of backing material 12 and heat-dissipating block 14 can be variably formed, as shown in Fig. 7 ~ Fig. 10 of Patent Document 1. In that case, the void need to be formed so that thickness U_b between the surface of bonded surface side of void 60 or void 72 and the bonded surface will be an integral multiplication of the wavelength of the ultrasonic wave, corresponding to the shape of the bonded surface.

First illustrative example

[0056] A first illustrative example of an ultrasonic probe will be described. The present example is different in a point

that the void is made hollow, from the first embodiment in which the void is filled with the sound absorbing material. Therefore, points of difference will be mainly described, by using the same symbols for the places relatively corresponding to the first embodiment.

[0057] The present example will be described referring to Fig. 1.

In accordance with the present example, since void 16 is made hollow as formed, difference of acoustic impedance between void 16 and heat-dissipating block 14 becomes comparatively large. Therefore, the incoming ultrasonic wave from backing material 12 to heat-dissipating block 14 is reflected to a different direction from incoming direction at round surface 26 that forms void 16, whereby enabling reduction of the reflected waves returning to the side of transducer 10.

[0058] Furthermore, the ultrasonic waves reflected at rounded surface 26 of void 16 repeat reflection at the boundary face of heat-dissipating block 14 or the surface of void 16. As a result, propagation path for the ultrasonic waves at heat-dissipating block 14 can be made longer than the thickness of heat-dissipating block 14. Therefore, since the ultrasonic wave is gradually attenuated in the process of being transmitted within heat-dissipating block 14, the reflected waves returning from heat-dissipating block 14 to the side of transducer 10 can be reduced, and noise can also be restrained.

[0059] Also, rounded surface 26 of void 16 does not have to be limited to the one of Fig. 1, and may take any shape. As long as it is formed so that at least a part of the surface on the side of transducer 10 of void 16 is not parallel to the bonded surface of the backside of transducer 10 or backing material 12 and heat-dissipating block 14, it can avoid the ultrasonic waves reflected at void 16 from directly returning to the side of transducer 10, whereby enabling the reduction of the reflected waves returning from the backside to the transducer side.

(The fourth embodiment)

[0060] The fourth embodiment of the ultrasonic probe to which the present invention is applied will be described referring to Figs. 9 and 10. The present embodiment is different from the first embodiment in shape and number of the voids. Therefore, points of difference will be mainly described, by using the same symbols for the places relatively corresponding to the first embodiment.

[0061] Fig. 9A is a diagram showing a cross section in axis direction of ultrasonic probe 1f of the present embodiment, viewing from major axis direction. As shown in Fig. 9, in ultrasonic probe 1f, a plurality of voids 60 is formed in bonded section 14a of heat-dissipating block 14. Each void 60 passes through bonded section 14a in major axis direction, and is formed having a cross section that is approximately round shape. Diameter U_a of each cross-sectional shape is designed as, for example, 5mm. And sound absorbing material 60 may be filled in at least one of the plurality of voids 60. Fig. 9A shows an example that all of the voids are filled with sound absorbing material 62. As for the material for sound absorbing material 62, it is the same as those in the first embodiment.

[0062] Each of the plurality of voids 60 is formed so that they have the same distance from the backside surface of backing material 12 (that is the bonded surface of backing surface 12 and bonded section 14a), and that thickness U_b from the backside of backing material 12 to the upper surface of the respective voids (end surface of the transducer side) will be an integral multiplication of the wavelength of the ultrasonic waves. In this example, the case that thickness U_b is set as, for example, 3.4mm being the same as the wavelength of the ultrasonic wave is described. Also, a gap between minimum thickness U_c from the rounded surface of void 60 of both ends to the sidewall of bonded section 14a and the void is designed as, for example, 1mm.

[0063] In accordance with the present embodiment, as with the previously mentioned effect in the third embodiment, since thickness U_b is small being the same as the wavelength of the ultrasonic wave, the incoming ultrasonic waves from backing material 12 to bonded section 14a passes through the part equivalent to thickness U_b , and vast majority of them are attenuated at sound absorbing material 62 of the respective voids 60. By this effect, the ultrasonic waves returning from heat-dissipating block 14 to the side of backing material 12 can be restrained, and multiple noises can be reduced.

[0064] Also, when heat of backing material 12 is transmitted to heat-dissipating block 14, the heat is carried to the side of extended section 14b via the part equivalent to thickness U_c and the gap portion of the respective voids. In other words, since the part equivalent to thickness U_c and the gap portion of the respective voids operate as the heat transfer channel, it is unnecessary to impose other members to operate as the heat transfer channel, whereby contributing to simplify the configuration of the ultrasonic probe 1f.

[0065] Fig. 9B is a diagram showing a cross section in axis direction of ultrasonic probe 1g of another example of the present embodiment, viewing from minor axis direction (direction of arrow X in the diagram). As shown in Fig. 9B, a point of ultrasonic probe 1g that is different from the example of Fig. 9A is that a plurality of voids 70 passing through bonded section 14a in minor axis direction is formed in place of the plurality of voids 60 passing through bonded section 14a in major axis direction. It is the same as Fig. 9A that the respective plurality of voids 70 may be formed to have the same distance from the backside of backing material 12 (that is the bonded surface of backing material 12 and bonded section 14a) It also is the same as Fig. 9A that at least one of such plurality of voids 70 is to be filled in with sound absorbing material 62. Fig. 9B indicates the example that all of the voids is filled in with sound absorbing material 62.

As for the material of sound absorbing material 62, it is the same as those in embodiment 1.

Also, thickness U_b from the backside of backing material 12 to the upper surface of the plurality of voids 70, minimum thickness U_c from the rounded surface of the void of both ends to the sidewall of bonded section 14a, and concrete measurement of the gap between the voids are the same as the case of Fig. 9A. By such configuration, the same effect as the example in Fig. 9A can be attained.

[0066] While an example illustrated in the embodiment shown in Fig. 9 used the approximately round shape for the cross-sectional shape of the void, other shapes may be used without limiting to the round shape. An embodiment using another cross-sectional shape will be illustrated in Fig. 10.

Fig. 10A is a diagram showing a cross section in axis direction of ultrasonic probe 1j of another example of the present embodiment, viewing from major axis direction. Fig. 10B is a diagram showing a cross section of ultrasonic probe 1k of another example of the present embodiment, viewing from minor axis direction (direction of arrow X in the diagram) In either example, a plurality of voids 60 and 70 having approximately triangle shape is formed in each probe, and adjacent voids have the inverted formation with respect to the backside direction (direction of arrow Y in the diagram).

[0067] Also, the respective plurality of voids 60 and 70 are formed to have the same distance from the backside of backing material 12 (that is the bonded surface of backing material 12 and bonded section 14a). Concrete measurement of the respective sections is the same as the case of Fig. 9, and thickness U_b from the backside of backing material 12 to the upper surface of the respective voids (end surface on the transducer side) is formed to be an integral multiplication of the wavelength of the ultrasonic wave. In this example, thickness U_b is designed as, for example, 3.4mm being the same as the wavelength of the ultrasonic wave. Also, the gap between minimum thickness U_c from the apex of the void at both ends to the sidewall of bonded section 14a and the void is designed as, for example, 1mm. With such configuration, the same effect as the example in Fig. 9 can be attained.

[0068] While an example is described in the above-mentioned embodiment that the respective plurality of voids are formed having the same size and shape, at least two of the size and shape of the respective plurality of voids may be different. For example, voids having cross-sectional shapes such as approximately round or polygon may be formed in random order. In that case, what is necessary is that the upper surface of the plurality of voids (end surface on the transducer side) closest from the backside of backing material 12 (that is the bonded surface of backing material 12 and bonded section 14a) is formed along the surface parallel to the backside of backing material 12, and thickness U_b from the backside of backing material 12 to the upper surface of the plurality of voids (end surface on the transducer side) is formed to be an integral multiplication of the wavelength of the ultrasonic wave.

[0069] While the present invention have been described as above in the first ~ fourth embodiments, it does not have to be limited to the above-mentioned embodiments.

For example, while the example is described that the surface for transmitting/receiving ultrasonic waves of transducer 10 has a rectangular shape, the present invention can also be applied to the surface having a circular shape. What is necessary for the present invention to be applied is that at least backing material 12 is imposed on the backside of transducer 10 as the backside section, and preferably that backing material 12 and heat-dissipating block 14a are imposed on the backside of transducer 10 as the backside section.

Also, condition such as disposing position, shape and number of the void does not have to be limited to the previously mentioned first - fourth embodiments, and embodiments described below are also applicable.

[0070] For example, a plurality of voids may be formed in longitudinal direction of heat-dissipating block 14 having intervals therebetween. The example thereof is illustrated in Fig. 11(A). Fig. 11(A) is a diagram showing a cross section in axis direction of the ultrasonic probe viewing from major axis direction, wherein only the backside is illustrated and the other portions are omitted. Figs. 11(B) ~ (D) are illustrated in the same manner as Fig. 11 (A). Fig. 11 (A) is a diagram showing an example that a void with thickness U_{a1} is formed leaving a void, from the backside of backing material 12, having thickness U_{b1} which is an integral multiplication of the wavelength of the ultrasonic wave. A void with thickness U_{a2} is further formed leaving a void having thickness U_{b2} which is an integral multiplication of the wavelength of the ultrasonic wave, then a void with thickness U_{a3} is formed leaving a void having thickness U_{b3} which is multiplication of the wavelength of the ultrasonic wave, and a void with thickness U_{a4} is formed leaving a void having thickness $n\lambda$ which is an integral multiplication of the wavelength of the ultrasonic wave. The respective voids may be filled with sound absorbing material. In addition, while 4 voids are formed in the example shown in Fig. 11(A), the number of voids to be formed may be 2, 3 or more than 5.

[0071] Also, for example, the void may be formed straddling from bonded section 14a of heat-dissipating block 14 to extended section 14b. In other words, thickness of the void can be arbitrarily designed in a range that sufficient attenuation effect can be obtained. The example thereof is shown in Fig. 11 (B). Fig. 11 (B) shows an example that the void is formed from bonded section 14a of heat-dissipating block 14 to extended section 14b. The void may be filled with an sound absorbing material.

[0072] Also, for example, the void may be formed in backing material 12. The example thereof is shown in Fig. 11(C). In an example of Fig. 11 (C), thickness U_b from the surface on the transducer 10 side of backing material 12 to the upper surface of the void (end surface on the transducer side) is designed to be an integral multiplication of the wavelength of

the ultrasonic wave. And the void can be filled with an sound absorbing material. In accordance with this illustrative example, majority of the incoming ultrasonic waves from the transducer to the backing material is attenuated at the sound absorbing material of the void after passing through the part equivalent to thickness U_b . By such configuration, ultrasonic waves returning to the transducer can be restrained, and multiple noises can be reduced.

5 **[0073]** Also, for example, the void may be formed in both backing material 12 and heat dissipating block 14. The example thereof is shown in Fig. 11(D). Fig. 11(D) shows an example that the void having thickness U_{a1} is formed in backing material 12 by spacing, from the backside of transducer 10, thickness U_{b1} which is an integral multiplication of the wavelength of the ultrasonic wave. The void having thickness U_{a2} is further formed in heat-dissipating block 14 by spacing, from the backside of backing material 12, thickness U_{b2} which is an integral multiplication of the wavelength of the ultrasonic wave. And the respective voids may be filled with an sound absorbing material.

10 **[0074]** The configuration may also be, for example, the arbitrary combination of the above-mentioned examples in Fig. 11(A) ~ (D). Moreover, while the example is described that the void is formed in major direction of the ultrasonic probe in Fig. 11 (A) ~ (D), it may also be formed in minor axis direction in the same manner of the above-mentioned Fig. 11 (A) ~ (D).

15 In addition, shape of the void does not have to be limited to the ones shown in the examples in the above-mentioned Figs. 11(A) ~ (D), and one or more voids in different sizes having the cross sections in a shape of, for example, approximate circle, triangle or polygon as shown in Figs. 9 and 10 may be formed.

Brief Description of the Diagrams

20 **[0075]**

Fig. 1 is a block diagram showing an ultrasonic probe of the first embodiment to which the present invention is applied. Fig. 2 is a block diagram showing an ultrasonic diagnostic apparatus to which the ultrasonic probe of Fig. 1 is connected.

Fig. 3 is a display example of ultrasound images imaged by the ultrasonic diagnostic apparatus of Fig. 2.

Fig. 4 is a diagram for illustrating the position of the void formed in the ultrasonic probe of Fig. 3.

Fig. 5 is a block diagram showing the ultrasonic probe of the second embodiment to which the present invention is applied.

Fig. 6 is a block diagram showing the ultrasonic probe of the third embodiment to which the present invention is applied.

Fig. 7 is a block diagram showing a first other example of the ultrasonic probe in Fig. 6.

Fig. 8 is a block diagram showing a second other example of the ultrasonic probe in Fig. 6.

Fig. 9 is a block diagram showing an ultrasonic probe of the fourth embodiment to which the present invention is applied.

Fig. 10 is a block diagram showing another example of the ultrasonic probe in Fig. 9.

Fig. 11 is a diagram showing another example of the arrangement example of the voids.

Description of the Symbols

40 **[0076]** 1... ultrasonic probe, 10... transducer, 12... backing material, 14... heat-dissipating block, 16... void, 18... sound absorbing material.

45 **Claims**

1. An ultrasonic probe comprising:

a transducer (10) for transmitting/receiving ultrasonic waves to and from an object to be examined; and
a backside section disposed on the backside of the transducer,
50 wherein the backside section comprises:

a first attenuation section (12) disposed on the backside of the transducer, for attenuating ultrasonic waves effused from the transducer; and

a heat-dissipating section (14) disposed on the backside of the first attenuation section, for dissipating heat from the first attenuation section,

55 **characterized in that** the backside section further comprises a second attenuation section for further attenuating the ultrasonic waves effused from the transducer, wherein the second attenuation section is formed by at least one void (16) in the heat-dissipating section, wherein the at least one void is positioned

EP 1 825 814 B1

apart from the bonded surface of the heat-dissipating section (14) and the first attenuation section (12), and is filled with a sound absorbing material (18).

- 5 2. The ultrasonic probe according to claim 1, wherein the second attenuation section (16, 18, 60, 70) is formed so that the position of the end surface on the transducer side of the second attenuation section falls on a position apart from the bonded surface in vertical direction to the backside of the transducer, by an integral multiple of the wavelength of the ultrasonic wave.
- 10 3. The ultrasonic probe according to claim 1, wherein the second attenuation section (16, 18, 60, 70) is formed in at least a part of the backside section in longitudinal direction of the transducer (10).
- 15 4. The ultrasonic probe according to claim 1, wherein the second attenuation section (16, 18, 60, 70) is formed in at least a part of the backside section in minor direction of the transducer (10).
- 15 5. The ultrasonic probe according to claims 3 or 4, wherein the second attenuation section (16, 18, 60, 70) is formed passing through from one to the other surface of the backside section.
- 20 6. The ultrasonic probe according to claim 1, wherein:
20 the heat-dissipating section (14) has a bonded section (14a) with the first attenuation section (12) and an extended section (14b) extended from the bonded section in vertical direction to the backside of the transducer; and
20 the second attenuation section (16, 18, 60, 70) is formed in the bonded section and/or the extended section.
- 25 7. The ultrasonic probe according to claim 1, wherein the at least one void (16, 60, 70) is formed by two surfaces parallel to the backside of the transducer (10), and a rounded surface for connecting the two surfaces thereof.
- 30 8. The ultrasonic probe according to claim 7, wherein at least a part of the surface on the first attenuation section side out of the two surfaces is formed not to be parallel to the bonded surface.
- 30 9. The ultrasonic probe according to claim 1, wherein the second attenuation section is formed by a plurality of voids (60, 70), and two or more of the respective voids are formed so that their positions of the surface on the transducer side have the same distance from the bonded surface.
- 35 10. The ultrasonic probe according to claim 1, wherein in that the cross-sectional shape of the at least one void (60, 70) is approximately circular.
- 40 11. The ultrasonic probe according to claim 1, wherein in that the cross-sectional shape of at the least one void (60, 70) is approximately triangular.
- 40 12. The ultrasonic probe according to claim 11, wherein the second attenuation section is formed by two adjacent voids having the approximately triangular shape being mutually inverted with respect to the vertical direction to the backside of the transducer (10).
- 45 13. The ultrasonic probe according to claim 1, **characterized in that** the sound absorbing material (18) includes silicone or epoxide resin.
- 50 14. The ultrasonic probe according to claim 1, wherein the second attenuation section is formed in the heat-dissipating section (14) so that at least part of the heat-dissipating section (14) operates as a heat transfer channel in vertical direction to the backside of the transducer(10).
- 50 15. The ultrasonic probe according to claim 1, wherein:
55 the heat-dissipating section (14) has a first heat-dissipating section that is bonded to the first attenuation section (12), a second heat-dissipating section formed in a position apart farther from the transducer than the first heat-dissipating section, and a connecting section for thermally and mechanically connecting the first heat-dissipating section and the second heat-dissipating section; and
55 the second attenuation section is sandwiched between the first heat-dissipating section and the second heat-

dissipating section.

16. An ultrasonic diagnostic apparatus comprising:

- 5 the ultrasonic probe (1) of claim 1;
 a transmission/reception unit (30) for providing drive signals to the ultrasonic probe and processing the receiving signals outputted from the probe;
 a phasing addition unit (32) for performing phasing addition on the receiving signals output from the transmission/reception unit;
 10 an imaging construction unit (34) for reconstructing ultrasound images based on the receiving signals output from the phasing addition unit; and
 a display unit (36) for displaying the ultrasound image output from the image constructing unit.

15 **Patentansprüche**

1. Ultraschallsonde, umfassend:

20 eine Umwandlungseinrichtung (10) zum Übertragen/Empfangen von Ultraschallwellen zu bzw. von einem zu untersuchenden Objekt und
 einen Rückseitenbereich, der auf der Rückseite der Umwandlungseinrichtung angeordnet ist, wobei der Rückseitenbereich umfasst:

25 einen ersten Abschwächungsbereich (12), der auf der Rückseite der Umwandlungseinrichtung angeordnet ist, zum Abschwächen von Ultraschallwellen, die von der Umwandlungseinrichtung verbreitet worden sind; und

einen Wärmeabführungsbereich (14), der auf der Rückseite des ersten Abschwächungsbereichs angeordnet ist, zum Abführen von Wärme aus dem ersten Abschwächungsbereich,

30 **gekennzeichnet dadurch, dass** der Rückseitenbereich ferner einen zweiten Abschwächungsbereich zum weiteren Abschwächen der von der Umwandlungseinrichtung verbreiteten Ultraschallwellen umfasst, wobei der zweite Abschwächungsbereich durch mindestens einen Zwischenraum (16) im Wärmeabführungsbereich gebildet wird, wobei der mindestens eine Zwischenraum von der Verbindungsoberfläche des Wärmeabführungsbereichs (14) und des ersten Abschwächungsbereichs (12) entfernt positioniert ist und mit einem schallabsorbierenden Material (18) gefüllt ist.

35 2. Ultraschallsonde nach Anspruch 1, wobei der zweite Abschwächungsbereich (16, 18, 60, 70) so ausgebildet ist, dass die Position der Endoberfläche auf der Umwandlungseinrichtungsseite des zweiten Abschwächungsbereichs auf eine Position fällt, die von der Verbindungsoberfläche in vertikaler Richtung zur Rückseite der Umwandlungseinrichtung hin um ein ganzzahliges Vielfaches der Wellenlänge der Ultraschallwelle entfernt ist.

40 3. Ultraschallsonde nach Anspruch 1, wobei der zweite Abschwächungsbereich (16, 18, 60, 70) in mindestens einem Teil des Rückseitenabschnitts in Längsrichtung der Umwandlungseinrichtung (10) ausgebildet ist.

4. Ultraschallsonde nach Anspruch 1, wobei der zweite Abschwächungsbereich (16, 18, 60, 70) in mindestens einem Teil des Rückseitenabschnitts in der Nebenrichtung der Umwandlungseinrichtung (10) ausgebildet ist.

45 5. Ultraschallsonde nach Anspruch 3 oder 4, wobei der zweite Abschwächungsbereich (16, 18, 60, 70) durchgehend von einer Oberfläche des Rückseitenabschnitts zur anderen ausgebildet ist.

50 6. Ultraschallsonde nach Anspruch 1, wobei:

der Wärmeabführungsabschnitt (14) einen Verbindungsabschnitt (14a) mit dem ersten Abschwächungsbereich (12) und einen vom Verbindungsabschnitt in vertikaler Richtung zur Rückseite der Umwandlungseinrichtung hin verlängerten Verlängerungsbereich (14b) aufweist; und

55 der zweite Abschwächungsbereich (16, 18, 60, 70) im Verbindungsbereich und/oder dem Verlängerungsbereich ausgebildet ist.

7. Ultraschallsonde nach Anspruch 1, wobei der mindestens eine Zwischenraum (16, 60, 70) durch zwei zur Rückseite

EP 1 825 814 B1

der Umwandlungseinrichtung (10) parallele Oberflächen und eine abgerundete Oberfläche zum Verbinden der zwei Oberflächen ausgebildet ist.

- 5 8. Ultraschallsonde nach Anspruch 7, wobei mindestens ein Teil der Oberfläche auf der Seite des ersten Abschwächungsbereichs aus den zwei Oberflächen so ausgebildet ist, dass er nicht parallel zur Verbindungsoberfläche ist.
- 10 9. Ultraschallsonde nach Anspruch 1, wobei der zweite Abschwächungsbereich durch mehrere Zwischenräume (60, 70) ausgebildet ist und zwei oder mehrere der jeweiligen Zwischenräume so ausgebildet sind, dass ihre Positionen auf der Oberfläche auf der Umwandlungseinrichtungsseite die gleiche Entfernung von der Verbindungsoberfläche aufweisen.
- 15 10. Ultraschallsonde nach Anspruch 1, wobei die Querschnittsform des mindestens einen Zwischenraums (60, 70) annähernd kreisförmig ist.
- 20 11. Ultraschallsonde nach Anspruch 1, wobei die Querschnittsform des mindestens einen Zwischenraums (60, 70) näherungsweise dreieckig ist.
- 25 12. Ultraschallsonde nach Anspruch 11, wobei der zweite Abschwächungsbereich durch zwei benachbarte Zwischenräume mit näherungsweise dreieckiger Form, die bezüglich der vertikalen Richtung der Rückseite der Umwandlungseinrichtung (10) wechselweise umgekehrt ist, ausgebildet ist.
- 30 13. Ultraschallsonde nach Anspruch 1, **gekennzeichnet dadurch, dass** das schallabsorbierende Material (18) Silikon oder Epoxidharz enthält.
- 35 14. Ultraschallsonde nach Anspruch 1, wobei der zweite Abschwächungsbereich im Wärmeabführungsbereich (14) ausgebildet ist, so dass mindestens ein Teil des Wärmeabführungsbereichs (14) als ein Wärmeleitkanal in vertikaler Richtung zur Rückseite der Umwandlungseinrichtung (10) dient.
- 40 15. Ultraschallsonde nach Anspruch 1, wobei:
der Wärmeabführungsbereich (14) einen ersten Wärmeabführungsbereich, der mit dem ersten Abschwächungsbereich (12) verbunden ist, einen zweiten Wärmeabführungsbereich, der in einer weiter entfernten Position von der Umwandlungseinrichtung als der erste Wärmeabführungsbereich ausgebildet ist, und einen Verbindungsbereich zur thermischen und mechanischen Verbindung des ersten Wärmeabführungsbereichs und des zweiten Wärmeabführungsbereichs aufweist; und
der zweite Abschwächungsbereich sandwichartig zwischen dem ersten Wärmeabführungsbereich und dem zweiten Wärmeabführungsbereich angeordnet ist.
- 45 16. Ultraschall-Diagnosevorrichtung, umfassend:
die Ultraschallsonde (1) nach Anspruch 1;
eine Übertragungs-/Empfangseinheit (30) zum Bereitstellen von Betriebssignalen für die Ultraschallsonde und Verarbeiten der von der Sonde ausgegebenen Empfangssignale;
eine Phasenadditionseinheit (32) zum Durchführen von Phasenaddition an den von der Übertragungs-/Empfangseinheit ausgegebenen Empfangssignalen;
eine Bildgebungskonstruktionseinheit (34) zum Wiederherstellen von Ultraschallbildern auf der Grundlage der Empfangssignale, die von der Phasenadditionseinheit ausgegeben werden; und
eine Anzeigeeinheit (36) zum Anzeigen des von der Bildgebungskonstruktionseinheit ausgegebenen Ultraschallbildes.
- 50

Revendications

- 55 1. Sonde ultrasonore comprenant :
un transducteur (10) pour émettre/recevoir des ondes ultrasonores vers/depuis un objet à examiner ; et
une section arrière agencée sur la face arrière du transducteur,
la section arrière comprenant :

une première section d'atténuation (12) agencée sur la face arrière du transducteur, pour atténuer des ondes ultrasonores émanant du transducteur ; et

une section de dissipation de chaleur (14) agencée sur la face arrière de la première section d'atténuation, pour dissiper de la chaleur provenant de la première section d'atténuation,

caractérisée en ce que la section arrière comprend en outre une seconde section d'atténuation pour atténuer davantage les ondes ultrasonores émanant du transducteur, la seconde section d'atténuation étant formée par au moins un vide (16) dans la section de dissipation de chaleur, l'au moins un vide étant positionné espacé de la surface collée de la section de dissipation de chaleur (14) et de la première section d'atténuation (12) et étant rempli d'un matériau absorbant acoustique (18).

2. Sonde ultrasonore selon la revendication 1, dans laquelle la seconde section d'atténuation (16, 18, 60, 70) est formée de telle manière que la position de la surface d'extrémité côté transducteur de la seconde section d'atténuation tombe sur une position espacée de la surface collée, dans la direction perpendiculaire à la face arrière du transducteur, par un multiple entier de la longueur d'onde de la sonde ultrasonore.

3. Sonde ultrasonore selon la revendication 1, dans laquelle la seconde section d'atténuation (16, 18, 60, 70) est formée dans au moins une partie de la section arrière dans une direction longitudinale du transducteur (10).

4. Sonde ultrasonore selon la revendication 1, dans laquelle la seconde section d'atténuation (16, 18, 60, 70) est formée dans au moins une partie de la section arrière dans une direction secondaire du transducteur (10).

5. Sonde ultrasonore selon la revendication 3 ou 4, dans laquelle la seconde section d'atténuation (16, 18, 60, 70) est formée traversante, d'une surface à l'autre de la section arrière.

6. Sonde ultrasonore selon la revendication 1, dans laquelle :

la section de dissipation de chaleur (14) comprend une section collée (14a) qui est collée à la première section d'atténuation (12) et une section allongée (14b) qui s'étend depuis la section collée dans la direction perpendiculaire à la face arrière du transducteur ; et

la seconde section d'atténuation (16, 18, 60, 70) est formée dans la section collée et/ou la section allongée.

7. Sonde ultrasonore selon la revendication 1, dans laquelle l'au moins un vide (16, 60, 70) est formé par deux surfaces parallèles à la face arrière du transducteur (10), et une surface arrondie pour relier ses deux surfaces.

8. Sonde ultrasonore selon la revendication 7, dans laquelle au moins une partie de la surface côté première section d'atténuation parmi les deux surfaces est formée pour ne pas être parallèle à la surface collée.

9. Sonde ultrasonore selon la revendication 1, dans laquelle la seconde section d'atténuation est formée par une pluralité de vides (60, 70), et deux des vides respectifs ou plus sont formés de telle manière que les positions de leur surface côté transducteur soient à la même distance de la surface collée.

10. Sonde ultrasonore selon la revendication 1, dans laquelle la forme de section transversale de l'au moins un vide (60, 70) est sensiblement circulaire.

11. Sonde ultrasonore selon la revendication 1, dans laquelle la forme de section transversale de l'au moins un vide (60, 70) est sensiblement triangulaire.

12. Sonde ultrasonore selon la revendication 11, dans laquelle la seconde section d'atténuation est formée par deux vides adjacents ayant la forme sensiblement triangulaire qui sont mutuellement inversés relativement à la direction perpendiculaire à la face arrière du transducteur (10).

13. Sonde ultrasonore selon la revendication 1, **caractérisée en ce que** le matériau absorbant acoustique (18) comprend une résine silicone ou époxy.

14. Sonde ultrasonore selon la revendication 1, dans laquelle la seconde section d'atténuation est formée dans la section de dissipation de chaleur (14) de telle manière qu'au moins une partie de la section de dissipation de chaleur (14) joue le rôle de canal de transfert de chaleur dans la direction perpendiculaire à la face arrière du transducteur (10).

15. Sonde ultrasonore selon la revendication 1, dans laquelle :

5 la section de dissipation de chaleur (14) comprend une première section de dissipation de chaleur qui est collée à la première section d'atténuation (12), une seconde section de dissipation de chaleur formée dans une position plus éloignée du transducteur que la première section de dissipation de chaleur, et une section de liaison pour relier thermiquement et mécaniquement la première section de dissipation de chaleur et la seconde section de dissipation de chaleur ; et

10 la seconde section d'atténuation est prise en sandwich entre la première section de dissipation de chaleur et la seconde section de dissipation de chaleur.

16. Appareil de diagnostic ultrasonore comprenant :

la sonde ultrasonore (1) selon la revendication 1 ;

15 une unité d'émission/réception (30) pour fournir des signaux d'excitation à la sonde ultrasonore et traiter les signaux de réception délivrés par la sonde ;

une unité d'addition en phase (32) pour effectuer une addition en phase sur les signaux de réception délivrés par l'unité d'émission/réception ;

20 une unité de construction d'image (34) pour reconstruire des images ultrasonores sur la base des signaux de réception délivrés par l'unité d'addition en phase ; et

une unité d'affichage (36) pour afficher l'image ultrasonore délivrée par l'unité de construction d'image.

25

30

35

40

45

50

55

FIG.1

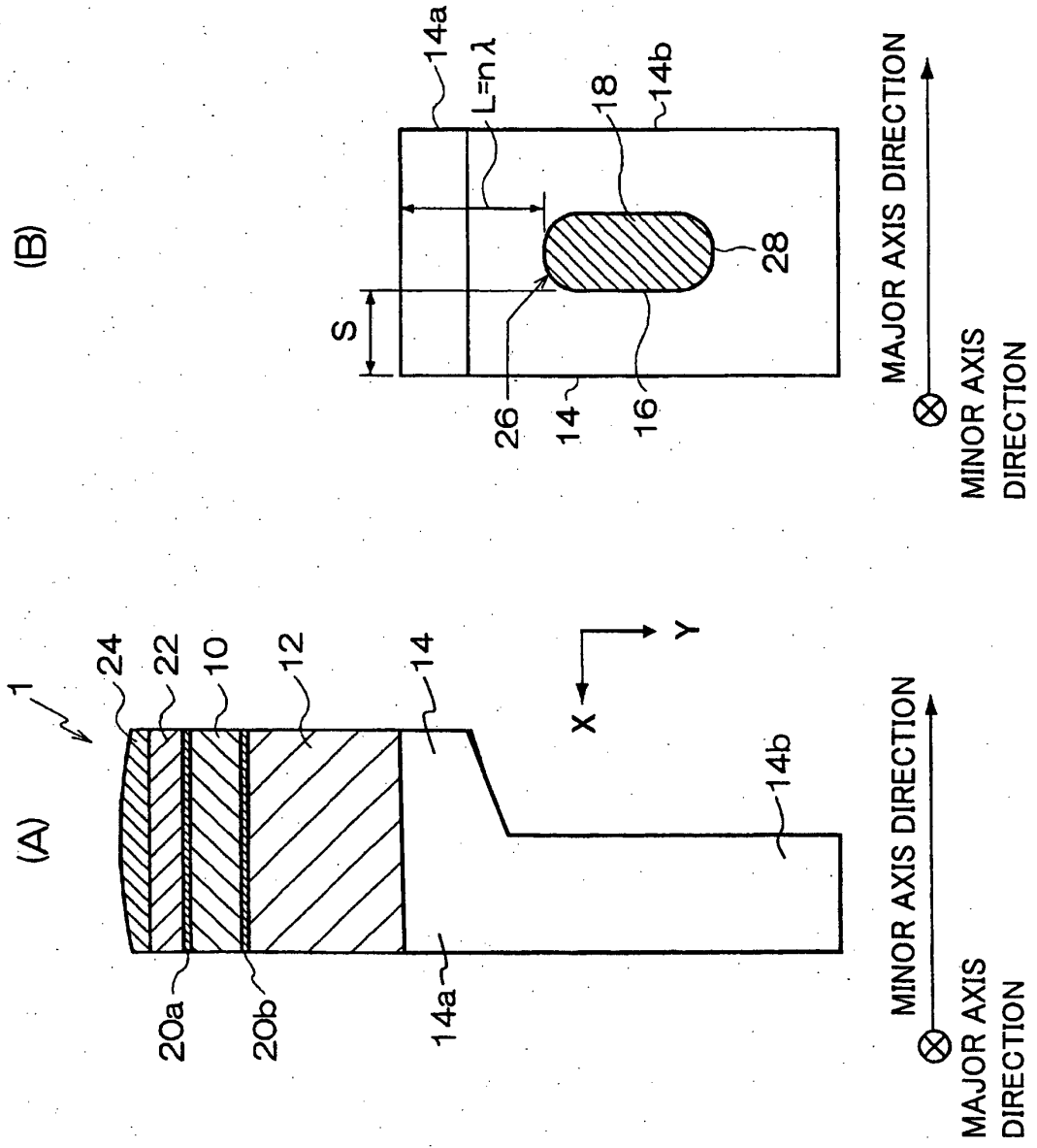

FIG.2

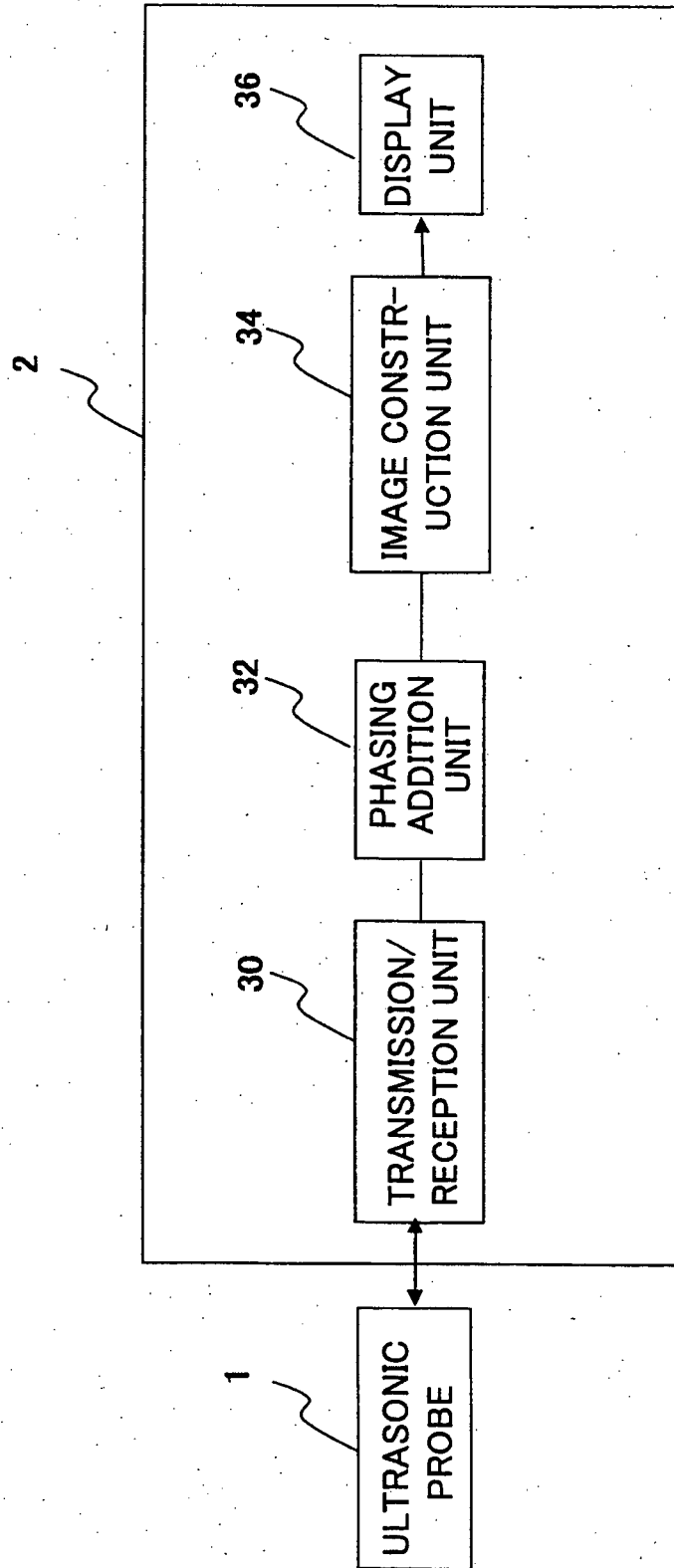
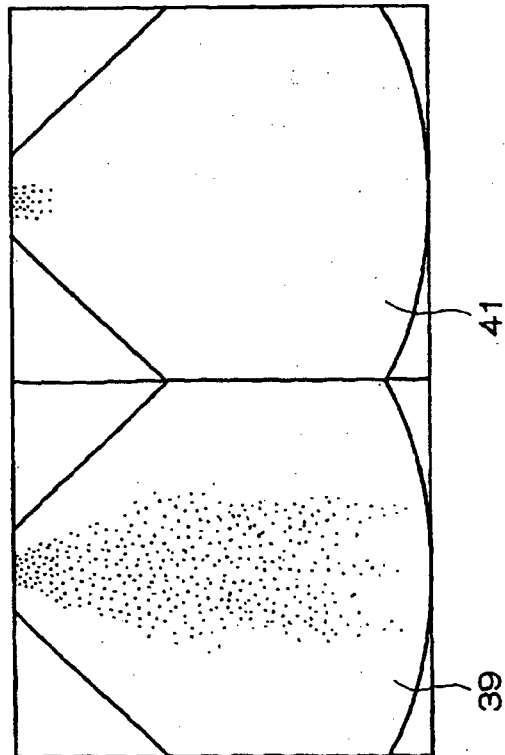

FIG.3

(A)



(B)

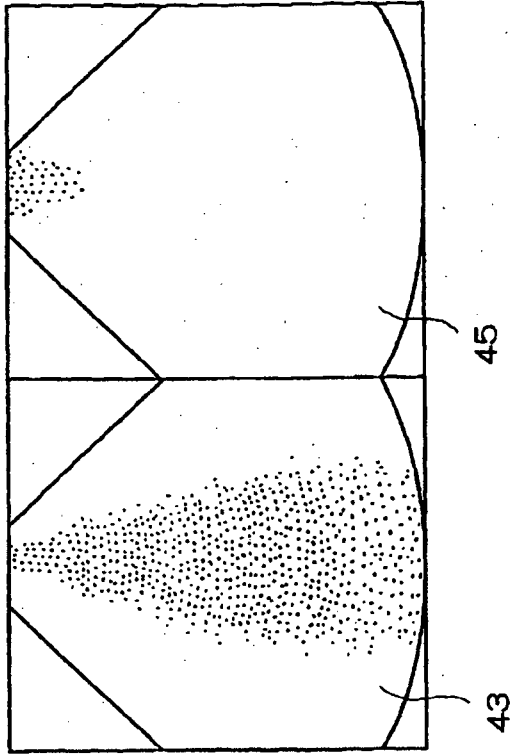

FIG.4

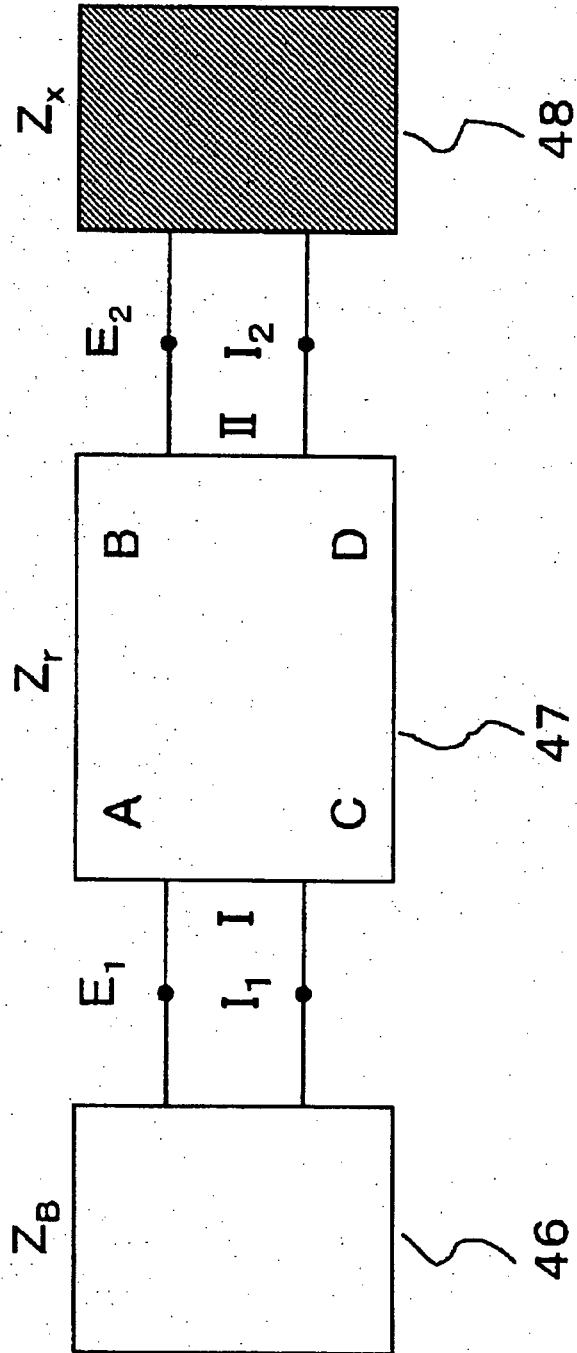
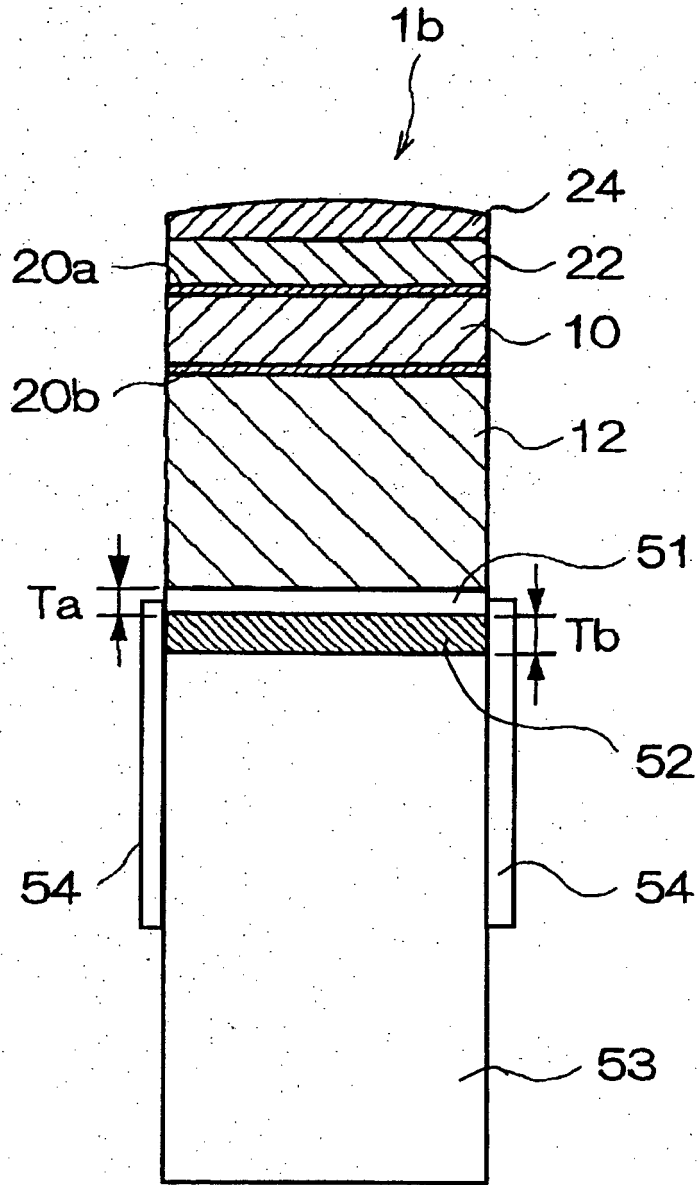
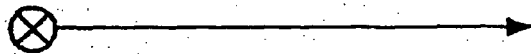

FIG.5



MAJOR AXIS DIRECTION



MINOR AXIS
DIRECTION

FIG.6

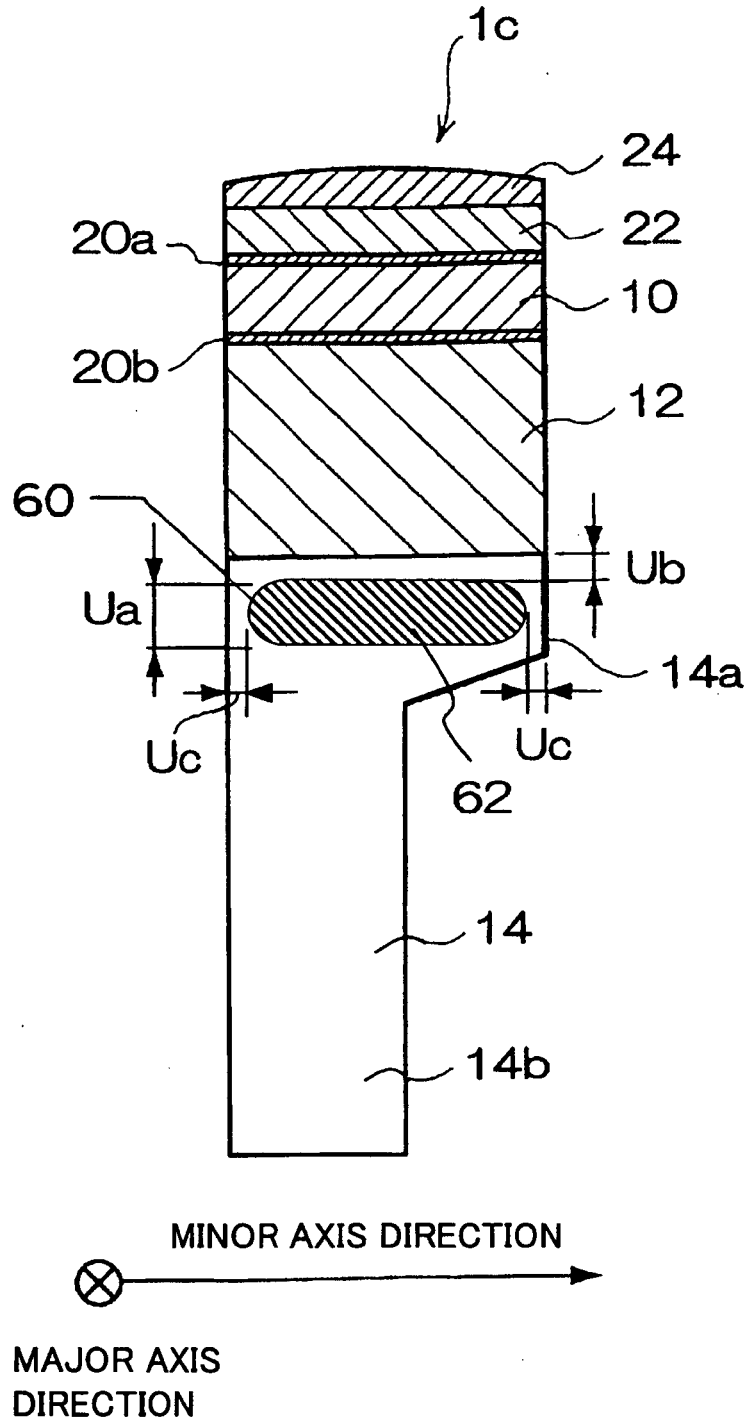

FIG.7

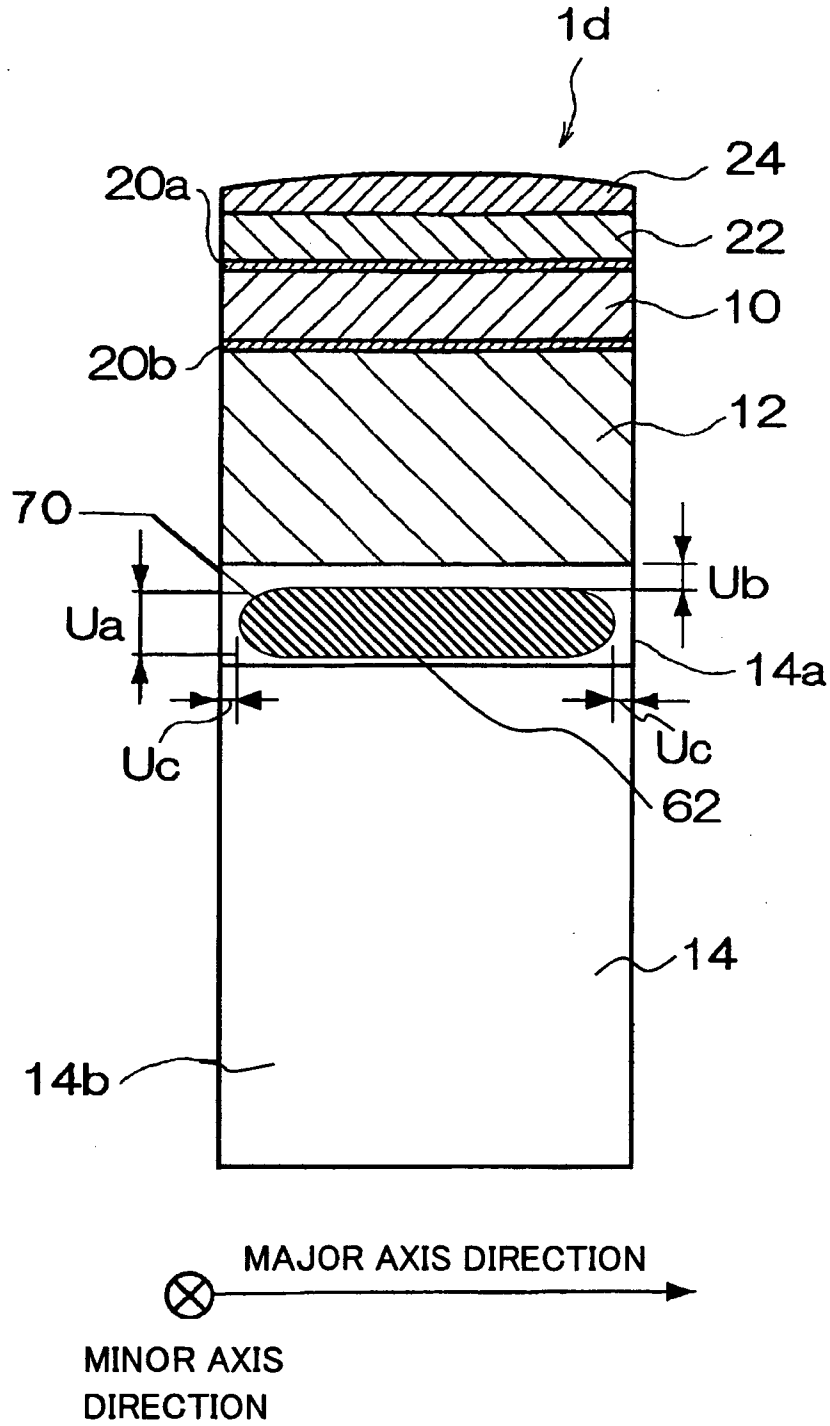
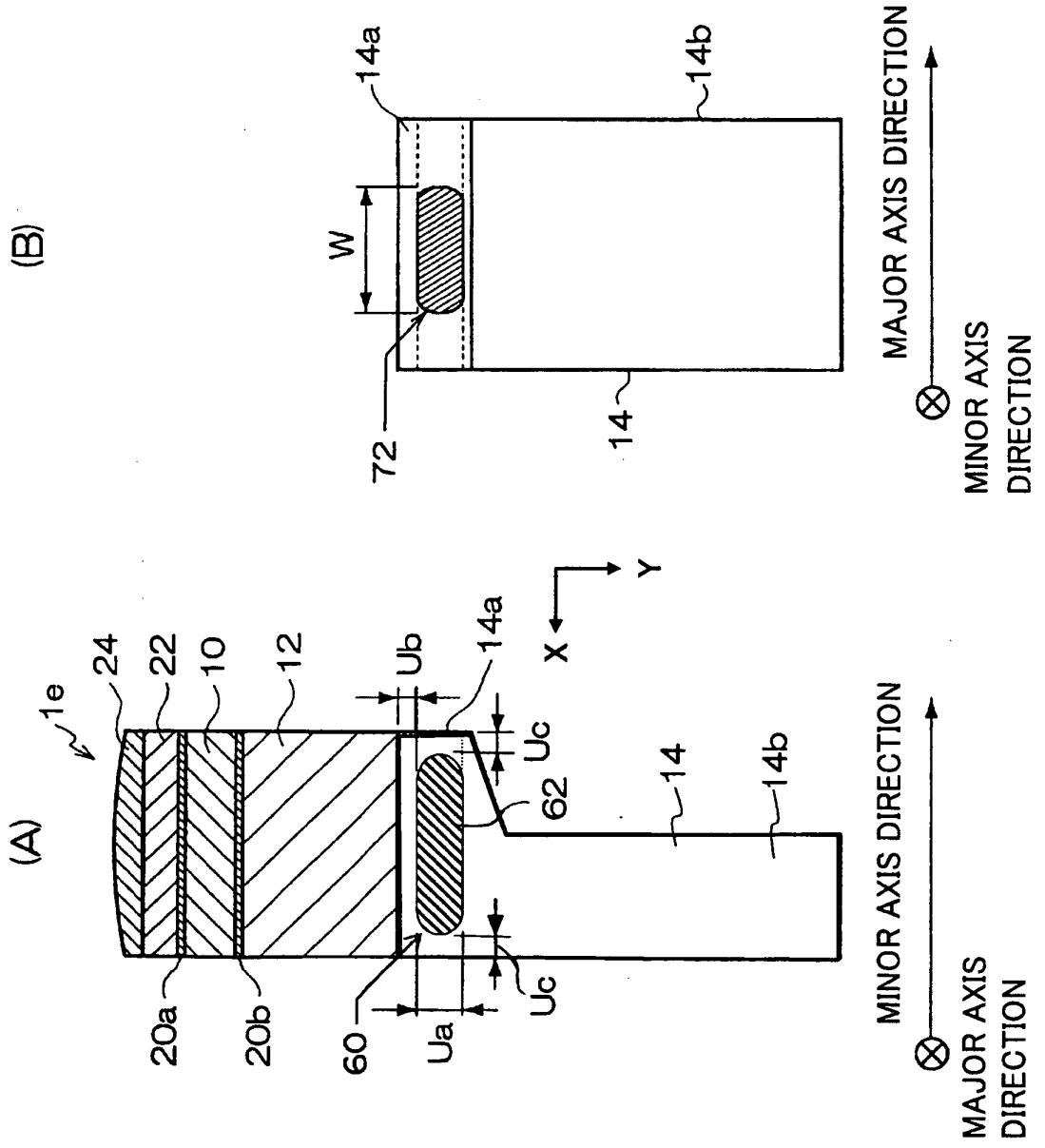
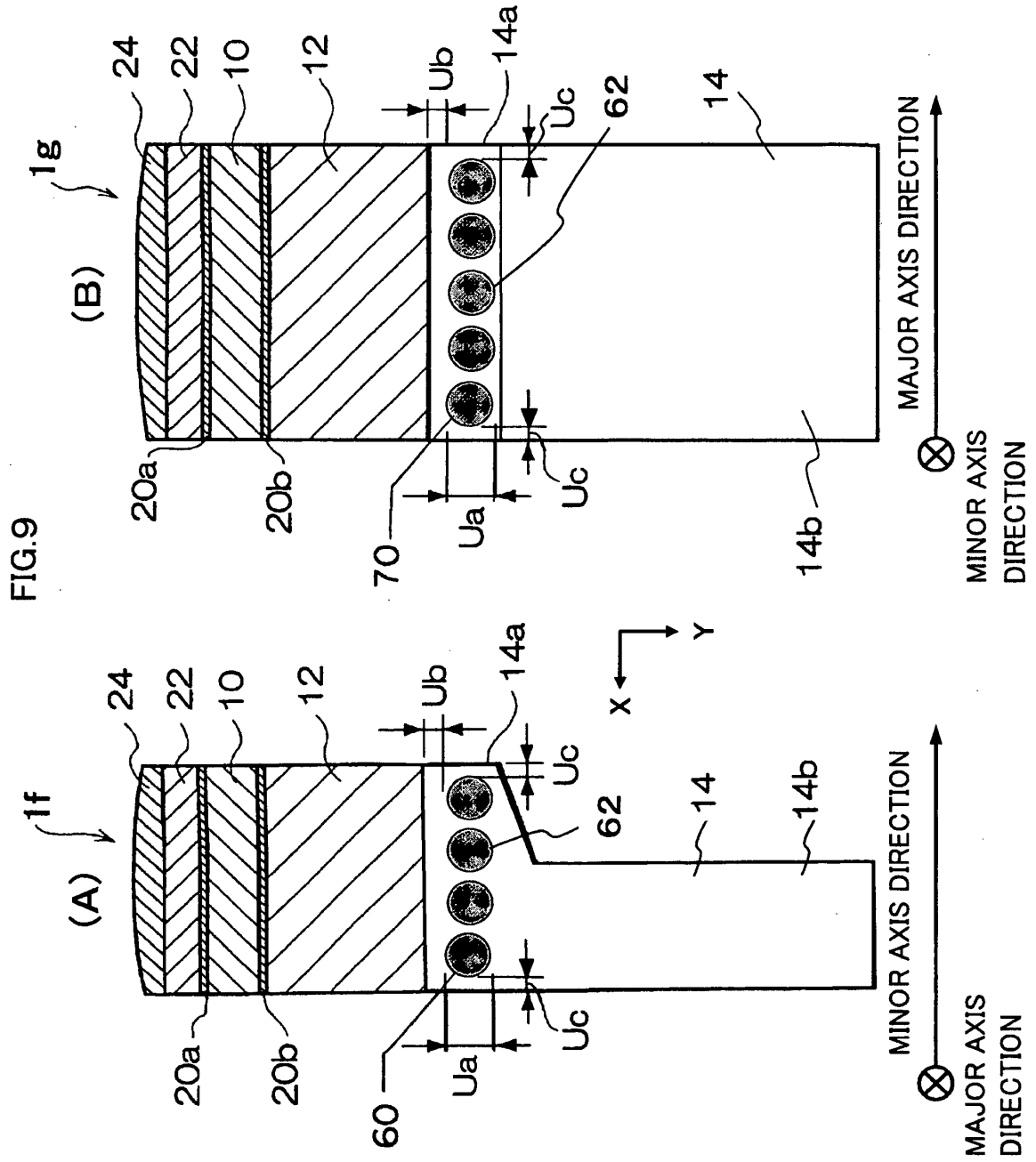

FIG.8





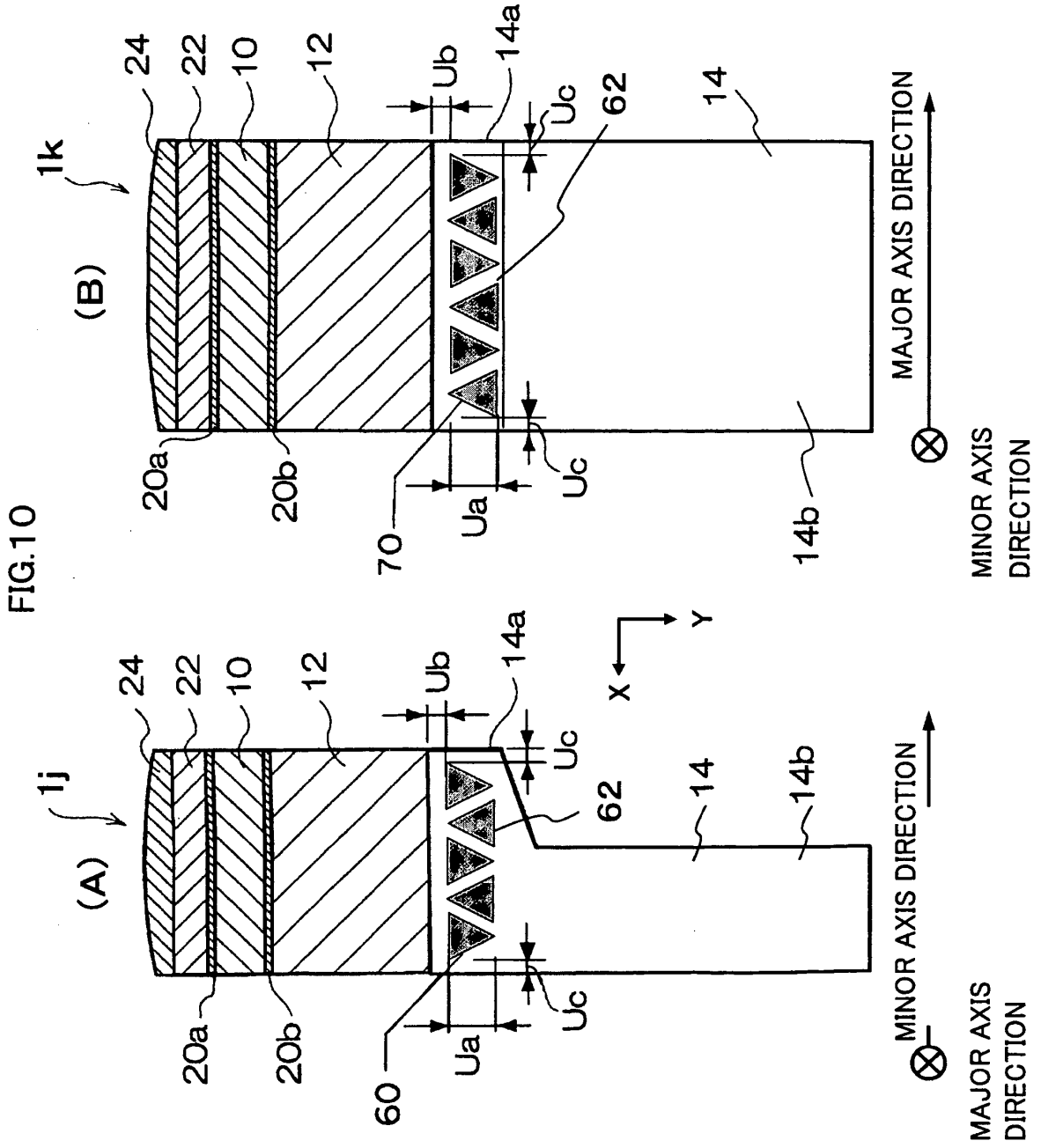
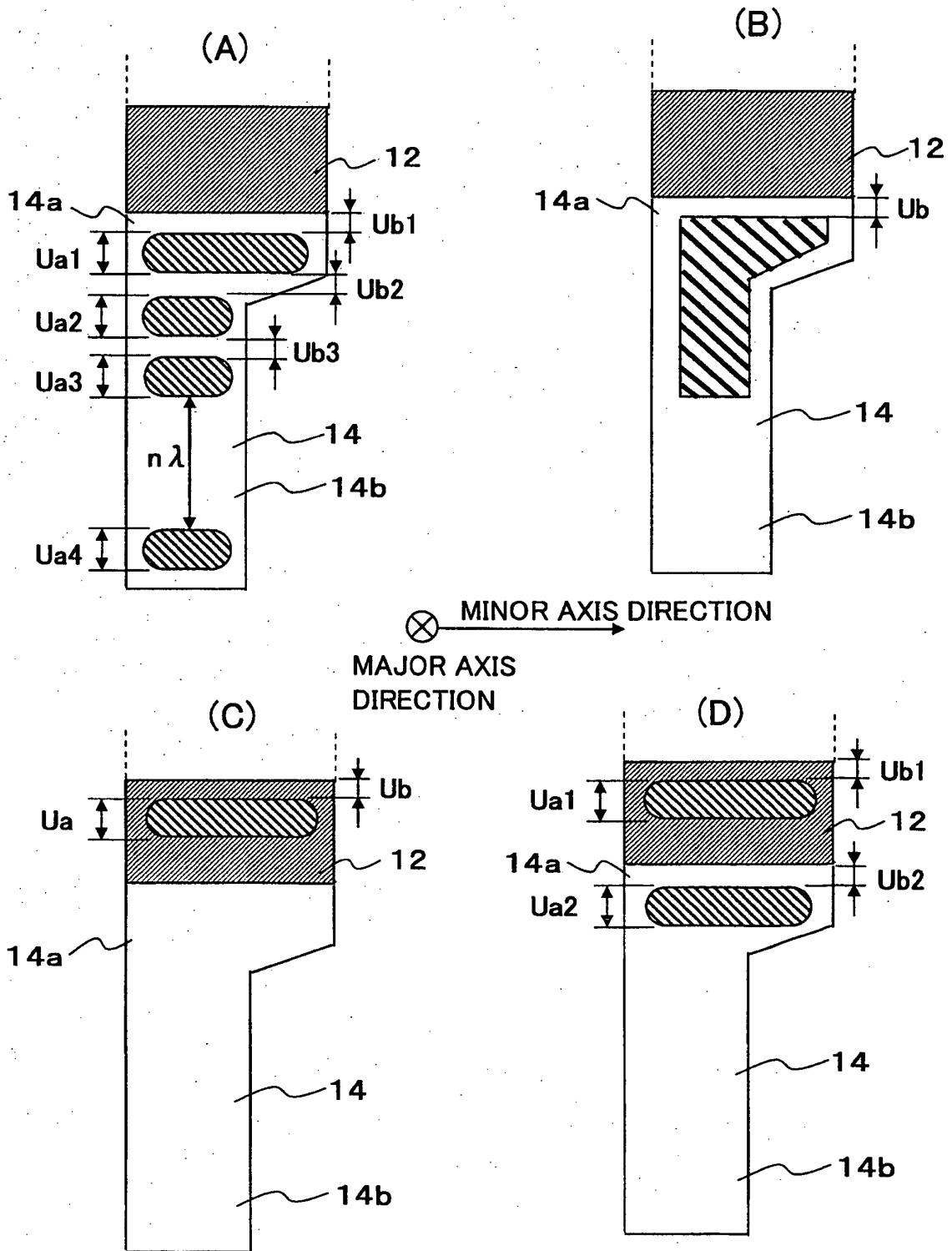

FIG. 11



REFERENCES CITED IN THE DESCRIPTION

This list of references cited by the applicant is for the reader's convenience only. It does not form part of the European patent document. Even though great care has been taken in compiling the references, errors or omissions cannot be excluded and the EPO disclaims all liability in this regard.

Patent documents cited in the description

- JP 2004329495 A [0004]
- EP 0727259 A2 [0004]
- US 6051913 A [0004]
- JP 1293851 A [0004]

专利名称(译)	超声波探头		
公开(公告)号	EP1825814B1	公开(公告)日	2013-02-20
申请号	EP2005814385	申请日	2005-12-08
[标]申请(专利权)人(译)	株式会社日立医药		
申请(专利权)人(译)	日立医疗器械股份有限公司		
当前申请(专利权)人(译)	日立医疗器械股份有限公司		
[标]发明人	HU ZHIQIANG		
发明人	HU, ZHIQIANG		
IPC分类号	A61B8/00		
CPC分类号	A61B8/00 B06B1/0618 G01S7/52017 G01S7/52079		
优先权	2004356971 2004-12-09 JP		
其他公开文献	EP1825814A1 EP1825814A4		
外部链接	Espacenet		

摘要(译)

一种超声波探头和超声波诊断装置，适用于减少从后表面部分返回到换能器侧的反射波。超声探头1包括向对象发送超声波和从对象接收超声波的换能器10，设置在换能器10后侧的背衬材料12，以及堆叠在背衬材料12背面上的散热块14中的至少一个。背衬材料12和散热块14在其中包括空隙16。吸声材料18理想地填充在空隙16中。

[Formula 1]

$$Z_{i1} = \frac{E_1}{I_1} = (AZ_x + B) / (CZ_x + D)$$