

(19)



(11)

EP 1 804 673 B1

(12)

EUROPEAN PATENT SPECIFICATION

(45) Date of publication and mention of the grant of the patent:
24.04.2013 Bulletin 2013/17

(51) Int Cl.:
A61B 8/12 (2006.01)

(21) Application number: **05810279.9**

(86) International application number:
PCT/US2005/036868

(22) Date of filing: **11.10.2005**

(87) International publication number:
WO 2006/044563 (27.04.2006 Gazette 2006/17)

(54) INTEGRATED BIAS CIRCUITRY FOR ULTRASOUND IMAGING DEVICES

INTEGRIERTER VORSPANNKREISLAUF FÜR ULTRASCHALL-BILDGEBUNGSGERÄTE

CIRCUITS DE POLARISATION INTEGRES POUR DISPOSITIFS D'IMAGERIE AUX ULTRASONS

(84) Designated Contracting States:
AT BE BG CH CY CZ DE DK EE ES FI FR GB GR HU IE IS IT LI LT LU LV MC NL PL PT RO SE SI SK TR

(74) Representative: **Pfenning, Meinig & Partner GbR**
Patent- und Rechtsanwälte
Joachimstaler Strasse 12
10829 Berlin (DE)

(30) Priority: **14.10.2004 US 966594**

(56) References cited:
GB-A- 2 368 123 US-A- 5 373 849
US-A1- 2001 016 688

(43) Date of publication of application:
11.07.2007 Bulletin 2007/28

(73) Proprietor: **Boston Scientific Limited**
Christ Church (BB)

- **ORALKAN O ET AL: "CMUT ring arrays for forward-looking intravascular imaging" ULTRASONICS SYMPOSIUM, 2004 IEEE MONTREAL, CANADA 23-27 AUG. 2004, PISCATAWAY, NJ, USA, IEEE, 23 August 2004 (2004-08-23), pages 403-406, XP010784117 ISBN: 0-7803-8412-1**

(72) Inventor: **KNIGHT, Jon M.**
Pleasanton, California 94588 (US)

EP 1 804 673 B1

Note: Within nine months of the publication of the mention of the grant of the European patent in the European Patent Bulletin, any person may give notice to the European Patent Office of opposition to that patent, in accordance with the Implementing Regulations. Notice of opposition shall not be deemed to have been filed until the opposition fee has been paid. (Art. 99(1) European Patent Convention).

DescriptionFIELD OF THE INVENTION

[0001] The systems and methods relate generally to the use of bias circuitry for biasing an ultrasound imaging device in an intravascular ultrasound imaging system.

BACKGROUND INFORMATION

[0002] To generate an image using a medical ultrasound imaging system, such as an intravascular ultrasound (IVUS) or intracardiac echocardiography (ICE) imaging system, an ultrasound imaging device, typically including one or more transducers, is located on or within an intravascular device, such as a catheter and the like. The intravascular device is navigated into the body and the imaging device is used to image the desired body tissue. To do this, the transducer generates and transmits an ultrasound pulse into the body tissue. As this pulse strikes various layers of body tissue, echoes are reflected back to and received by the transducer. The transducer generates an electrical output signal representative of the strength of the received echo and outputs this signal to an image processing system. The image processing system processes the signal and uses it to form an image of the body tissue.

[0003] Conventionally, ultrasound transducers have been made of piezoelectric materials which require ceramic manufacturing technologies which are vastly different from those used to manufacture other components in an ultrasound imaging system, which are typically semiconductor-based. Piezoelectric transducers typically have a narrow bandwidth which limits the depth of tissue that can be imaged.

[0004] Recently, a new type of transducer has been developed capable of fabrication with semiconductor-based processing technologies. Capacitive micromachined ultrasonic transducers (CMUTs) were designed to answer a need to mass fabricate medical ultrasound transducers using the very same semiconductor manufacturing processes used to fabricate the other parts of an external ultrasound imaging system. CMUTs are typically much smaller than piezoelectric transducers (on the order of 10 to 100 microns in size) and have a larger bandwidth.

[0005] A typical CMUT includes a drumhead structure suspended over a substrate in a manner to allow two-way conversion between a mechanical wave and an electrical signal through modulation of a capacitive charge on the drumhead. To deliver an ultrasound pulse, the capacitive charge on the drumhead, measured relative to a substrate electrode, is modulated by delivery of an electrical pulse to the drumhead. The delivery of this pulse causes the drumhead to vibrate and thereby transmit an ultrasound wave. Likewise, in the receiving mode, the impact of the echo on the drumhead modulates the capacitance and results in an electrical signal representative of the

strength of the received echo.

[0006] CMUT devices are not currently used in IVUS imaging systems. One reason for this is because in order to operate, the CMUT needs a constant bias voltage that is carefully controlled so as to maintain high transducer sensitivity without short-circuiting the transducer's capacitance. Accordingly, there is a need for systems and methods for applying this bias voltage to CMUT devices in intravascular ultrasound imaging systems.

[0007] An article entitled 'CMUT Ring Arrays for Forward-Looking Intravascular Imaging' by O. Oralkan et al, Ultrasonics Symposium, 2004 IEEE Montreal, Canada 23-27 August 2004, Piscataway, NJ, USA, IEEE 23 August 2004, pages 403-406 (XP010784117) describes an annular CMUT ring array designed and fabricated for the tip of a catheter used for forward-looking intravascular imaging. The transducer is biased using a high-voltage DC power supply coupled to the transducer on a supply line and receives a pulse drive signal used for excitation on another line via a Transmit/Receive switch.

SUMMARY

[0008] In accordance with the invention there is provided a medical imaging system as recited in claim 1 of the accompanying claims.

[0009] UK Patent Application GB 2 368 123 describes an ultrasonic transducer array arrangement suitable for mounting on a catheter. The device also includes a control arrangement that comprises means for applying a bias voltage to the array, to render the elements of the array significantly piezoelectric, and means for transmitting a receiving signal in relation to those transducer elements only when the bias voltage is being applied.

[0010] The systems and methods described herein provide for an imaging system having bias circuitry for applying a bias voltage to one or more transducers. The imaging system includes an imaging device insertable into a living being and configured to image the interior of the living being. The imaging device includes an ultrasound transducer and bias circuitry electrically coupled with the transducer and configured to electrically bias the transducer. The imaging device is coupled with a rotatable driveshaft and communicatively coupled with an image processing system. The image processing system is configured to output a transducer drive signal to the transducer over a signal line located along the driveshaft and supply charge to the bias circuitry over the same signal line. Preferably, the transducer is CMUT capable of fabrication in a semiconductor-based manufacturing process. In one embodiment, the transducer is a CMUT and is integrated with the bias circuitry on a common semiconductor substrate. The bias circuitry can include a charge pump for accumulating the bias voltage and also charge limiting circuitry for controlling the bias voltage,

[0011] systems and methods described herein also provide for an image processing system configured to

operate an imaging device having bias circuitry. In one example embodiment, the image processing system can be configured to output a transducer drive signal during a first time period, receive a transducer output signal during a second time period and output a bias signal during a third time period. The transducer drive signal can be configured to cause a transducer within the imaging device to generate an ultrasound pulse. The transducer output signal is preferably representative of an echo received by the transducer. The bias signal can be configured to provide electrical charge to bias circuitry coupled with the transducer.

[0012] The systems and methods described herein also provide for a method of ultrasound imaging with an image processing system. In one example embodiment, the method includes outputting a transducer drive signal during a first time period, where the transducer drive signal is configured to cause a transducer to transmit an ultrasound pulse. The method also includes receiving a transducer output signal during a second time period following the first time period, where the transducer output signal is representative of an echo received by the transducer, and outputting a bias signal during a third time period following the second time period, where the bias signal is configured to provide charge to bias circuitry. In another example embodiment, the method can include outputting a second bias signal during a fourth time period prior to the first time period, where the second bias signal output during the fourth time period is configured to initialize the bias circuitry. The fourth time period can also be longer than the third time period.

[0013] Other systems and advantages of the invention will be or will become apparent to one with skill in the art upon examination of the following figures and detailed description. It is intended that all such additional systems, methods, features and advantages be included within this description, be within the scope of the invention, and be protected by the accompanying claims. It is also intended that the invention is not limited to require the details of the example embodiments.

BRIEF DESCRIPTION OF THE FIGURES

[0014] The details of the invention, including fabrication, structure and operation, may be gleaned in part by study of the accompanying figures, in which like reference numerals refer to like segments.

FIG. 1 is a schematic view depicting an example embodiment of an IVUS imaging system.

FIG. 2 is a perspective view depicting another example embodiment of an IVUS imaging system.

FIGs. 3A-B are cross-sectional views depicting an example embodiment of a CMUT.

FIG. 4 is a block diagram depicting an example embodiment of an IVUS imaging device.

FIG. 5 is a timing diagram depicting example output signals from an image processing system.

FIG. 6 is a flow diagram depicting a method of operating an imaging device with an image processing system.

5 DETAILED DESCRIPTION

[0015] The systems and methods described herein allow the application of a bias voltage to one or more transducers implemented within an imaging system. FIG. 1 depicts one example embodiment of an imaging system 100 having bias circuitry 102. Preferably, the imaging system 100 is an IVUS imaging system. Here, an intravascular medical device 104, such as a catheter and the like, is communicatively coupled with an image processing system 106. Catheter 104 is preferably configured to image the interior of a living being, such as a body chamber or body lumen and the like. Catheter 104 preferably includes a rotatable driveshaft 108 with an imaging device 110 coupled thereto. In this embodiment, the imaging device 110 is mounted on the distal end 111 of the driveshaft 108. The catheter 104 also preferably includes an elongate outer sheath (not shown) having an inner lumen for slidably receiving the driveshaft 108 and imaging device 110.

[0016] To perform an imaging procedure of, for example, a blood vessel, the catheter 104 can be inserted into the blood vessel and navigated into proximity with the desired imaging location. Once in position, the driveshaft 108 is rotated and the imaging device 110 is used to image the blood vessel by continuously transmitting ultrasound pulses and receiving echoes generated as the ultrasound pulse travels through the vessel tissue. Imaging device 110 outputs an output signal representative of the strength of the received echo over communication channel 140 to image processing system 120, where the signal can be processed and formed into an image of the blood vessel and surrounding body tissue.

[0017] A coupling device 130 can be used to couple the stationary image processing system 120 with the rotatable driveshaft 108. In one embodiment, coupling device 130 is an inductive coupling configured to transfer communication signals, such as the imaging device output signal and the transducer drive signal, between image processing system 120 and communication channel 140.

[0018] In this embodiment, the imaging device 110 includes one or more transducers 101 requiring a bias voltage for operation, such as a CMUT and the like. The imaging device 101 can operate with a single transducer 101 or with a transducer array having multiple transducers 101. Each transducer 101 is preferably fabricated using a semiconductor-based manufacturing technique, although any fabrication technique can be used. For ease of discussion, the transducer 101 will be described herein as a CMUT; however, one of skill in the art will readily recognize that the systems and methods described herein can be used with any transducer 101 requiring a bias voltage, such as other types of micromachined ultra-

sound transducers (MUTs) and the like. Accordingly, the systems and methods are not limited solely to the use of CMUT devices.

[0019] The imaging device 110 also includes bias circuitry 102 for applying a DC voltage bias to the CMUT 101. Preferably, the CMUT 101 and bias circuitry 102 are integrated together. FIG. 2 is a perspective view depicting a CMUT array 202 integrated with bias circuitry 102 on a common semiconductor substrate 204, such as Silicon, Gallium Arsenide (GaAs) and the like. The integrated CMUT array 202 and bias circuitry 102 are located within housing 208 and mounted on the distal end 111 of driveshaft 108. Housing 208 preferably includes an imaging window 210, which can be either an open portion of the housing 208 or a window formed from a material that does not significantly impede the transmission or reception of ultrasound signals. Although not depicted here, the integrated CMUT array 202 and bias circuitry 102 can be packaged using any desired packaging technique in order to provide protection, ease of mounting within housing 208 or for any other desired purpose.

[0020] As mentioned above, CMUTs 101 are typically fabricated using semiconductor-based manufacturing processes on a semiconductor substrate 204. Preferably, the bias circuitry 102 is integrally fabricated on the same substrate 204 as the CMUT 101. CMUT 101 and bias circuitry 102 can be fabricated using the same process flow or in different process flows. In embodiments having a CMUT array 202, bias circuitry 101 can be configured to bias each individual CMUT 101 in the array 202 or multiple bias circuits 101 can be provided to bias each CMUT separately. The integration of bias circuitry 102 with CMUT 101 allows for improved performance of the imaging device 110 while at the same time making fabrication of the imaging device easier and less costly. Although integration of CMUT 101 and bias circuitry 102 on common substrate 204 is preferred, it should be understood that the systems and methods described herein are not limited to such. For instance, CMUT 101 and bias circuitry 102 can be fabricated as discrete components and packaged together, or fabricated and packaged discretely. Furthermore, CMUT 101 and bias circuitry 102 are not required to be housed together within housing 208, and in fact can be positioned in any desired location within catheter 104.

[0021] FIGs. 3A-B are cross-sectional views depicting an example embodiment of a CMUT 101. FIG. 3A depicts an unbiased CMUT 101 having a flexible upper electrode 302 suspended over a lower electrode 304 both of which are fabricated on substrate 204. The flexible upper electrode 302 is also referred to in some contexts as a "drum-head." Located between electrodes 302 and 304 is an insulator layer 306, composed of an insulating material such as silicon oxide or the like. Preferably, upper electrode 302 and lower electrode 304 are separated by a gap 308. Upper electrode 302 can completely encase gap 308 on all sides, in which case gap 308 is preferably a vacuum.

[0022] FIG. 3B depicts CMUT 101 after a DC bias voltage 310 is applied across electrodes 302 and 304. DC bias voltage 310 builds a capacitive charge on the electrodes 302 and 304 causing upper electrode 302 to flex, or deflect, downwards towards lower electrode 304 in direction 312. The application of a drive signal, such as an electrical pulse or an AC signal, to the biased CMUT 101 modulates the degree of deflection of upper electrode 302 causing the generation of an ultrasound pulse, which can be used to image body tissue. Conversely, when an ultrasound pulse, such as a received echo, impacts the biased CMUT 101, an electrical pulse corresponding to the strength of the received echo is generated. In this manner, CMUT 101 can be used to transmit and receive ultrasound signals in IVUS imaging system 100.

[0023] The actual DC bias voltage 310 and drive signal levels are dependent on the needs of the application and the characteristics of each CMUT 101. In general, a larger DC bias voltage 310 will translate into the generation of a stronger ultrasound pulse. In addition, the bias voltage 310 can also be a factor in determining the frequency of the generated ultrasound pulse. In some applications, the DC bias voltage 310 can be approximately 100-150 volts, while the drive signal level can be 75 volts or more. It should be understood that these values are provided solely as examples and any signal levels can be used as desired.

[0024] The design and fabrication of CMUT devices is discussed further in Percin, G. and B. Khuri-Yakub, Piezoelectrically actuated flextensional micromachined ultrasound transducers, *Ultrasonics*, 2002. 40(1-8): p. 441-8, Percin, G. and B. Khuri-Yakub, Piezoelectrically actuated flextensional micromachined ultrasound transducers--II: fabrication and experiments, *IEEE Trans Ultrason Ferroelectr Freq Control*, 2002. 49(5): p. 585-95 and Percin, G. and B. Khuri-Yakub, Piezoelectrically actuated flextensional micromachined ultrasound transducers-I: theory, *IEEE Trans Ultrason Ferroelectr Freq Control*, 2002. 49(5): p. 573-84, each of which is fully incorporated by reference herein.

[0025] FIG. 4 depicts another example embodiment of imaging device 110. In this embodiment, imaging device 110 includes CMUT array 202, bias circuitry 102 and rectification circuit 402, all of which are preferably integrated on common substrate 204. Bias circuitry 102 includes a signal blocking circuit 404 and a charge pump 406 configured to apply the DC bias voltage 310 to the array 202. A bias signal is preferably transmitted along communication channel 140 to supply charge to charge pump 404 and generate the DC bias voltage level 310 necessary to properly bias the CMUTs 101 within array 202. The design and implementation of charge pumps are well known to those of skill in the art and any type of charge pump can be used. The charge pump preferably includes a charge storage unit, such as a switched capacitor bank and the like. Furthermore, DC bias circuitry 102 can be any circuitry configured to control and apply a DC bias

voltage including, but not limited to, a charge pump 404.

[0026] In embodiments where coupling device 130 uses an inductive or other non-physical electrical coupling to transfer AC signals between image processing system 120 and imaging device 110, the bias signal is preferably a series of DC pulses that appear as an AC signal to the coupling device 130. In embodiments where coupling device 130 uses a physical coupling, such as a brush/contact combination, the bias signal can be a pure DC signal if desired.

[0027] Rectification circuit 402 can be used to isolate the charge built up within imaging device 110. Because system 100 can be used primarily for medical imaging within living beings, rectification circuit 402 guards against the risk of electrical shock or other hazards to the patient or the circuitry of system 100. Specifically, rectification 402 can be used to block or prevent signals, such as the charge in charge pump 406 or array 202, from propagating onto communication channel 140. Any type of rectification circuitry can be used, such as one or more diodes and the like. Signal blocking circuit 404 can be used to block the CMUT drive signal from propagating to charge pump 406. One of skill in the art will readily recognize that FIG. 4 depicts one of many possible different circuit layouts for imaging device 110 and, accordingly, the systems and methods described herein are not limited to any one layout or circuit design.

[0028] Communication channel 140 can include any number of signal lines or transmission lines as needed. For example, communication channel can include a ground signal line, a CMUT drive signal line and a bias circuitry bias signal line. However, because system 100 is preferably used for intravascular applications, the width of catheter 104 can be a limiting factor preventing advancement through narrow vasculature. Thus, because each additional signal line generally adds width to the driveshaft 108, even if the driveshaft 108 itself is used as a signal line, the number of signal lines used in communication channel 140 is preferably minimized. Typical IVUS imaging systems use a communication channel 140 that includes two signal lines which can be used to transfer single-ended or differential signals.

[0029] In order to use two signal lines to transfer the transducer drive signal, the bias signal and the transducer output signal, the systems and methods described herein use a segmented timing regime. FIG. 5 is a timing diagram depicting the signals output from image processing system 120 according to one example embodiment of the segmented timing regime. In this embodiment, imaging device 110 is rotated to image a cross-section of the body lumen. The transmission of an ultrasound pulse followed by the reception of the resulting echo signals is referred to herein as an imaging cycle. System 100 can be configured to perform a predetermined number of imaging cycles for every rotation, with each imaging cycle being performed at a separate angular location, or range of angular locations. For instance, in one embodiment, imaging device 110 performs 360 imaging cycles in each

rotation, with one imaging cycle being performed at an angular location located one degree apart.

[0030] Preferably, imaging device 110 is rotated at a rate such that the time required to perform an imaging cycle is less than the time required to rotate the imaging device 110 from one angular location to the next. For example, in FIG. 5, at time T_0 the imaging device 110 is at a first angular location and at time T_4 the imaging device 110 has been rotated to a second angular position. The imaging cycle for the first angular location occurs between times T_0 and T_2 . More specifically, the CMUT drive signal 502 is transmitted from image processing system 120 to the array 202 from time T_0 to time T_1 in order to cause each individual CMUT 101 to transmit an ultrasound pulse. From time T_1 to time T_2 , image processing system 120 is in a receiving period 502 awaiting any output signals generated by the array 202 in response to received echoes. This leaves the remaining time from T_2 to T_4 unused in any imaging cycle.

[0031] During the time from T_2 to T_3 , the image processing system 120 preferably transmits the bias signal 504 to bias circuitry 102. At time T_4 , the image processing system 120 transmits another drive signal 501 to initiate the imaging cycle at the next angular location. In one example embodiment, the time period from T_0 to T_4 is 130 microseconds, with the time period from T_0 to T_1 being approximately 50 nanoseconds, the time period from T_1 to T_2 being approximately 20 microseconds and the time period from T_2 to T_3 being approximately 100 microseconds. These times are included as examples only and in no way limit the systems and methods described herein.

[0032] Bias circuitry 102 can use the bias signal to generate the required DC bias voltage 310. The amplitude of the bias signal 504 is preferably lower than the CMUT 101 excitement threshold where the CMUT 101 produces an ultrasound pulse. In some applications, small ultrasound pulses may be tolerable if, for instance, the small ultrasound pulse does not interfere with the subsequent imaging cycle. The term "excitement threshold" as used herein, refers to the signal level which causes one or more transducers to generate ultrasound pulses at a level sufficient to interfere with an imaging cycle. In one embodiment, the excitement threshold can be 75 volts and the bias signal 504 is maintained at 70 volts, while the drive signal 501 is 125 volts. These values are solely for example and in no way limit the systems and methods described herein. As mentioned above, the bias signal can be a series of DC pulses instead of a continuous DC pulse in order to propagate through coupling device 130, if needed. Also, it should be understood that any waveforms can be used for drive signal 501 and bias signal 504.

[0033] The generation of bias signal 504 and drive signal 501, as well as the proper timing for doing so, can be controlled by the image processing system 120. Preferably, the bias circuitry 102 is configured to limit the charge build up so that the bias signal 504 does not cause bias

circuitry 102 to apply a DC bias voltage 310 that is too high. This can be performed through charge limiting circuitry well known to those of skill in the art. Also, in certain applications, multiple charging cycles may be needed before bias circuitry 102 can apply the proper DC bias voltage 310. Alternatively, in another embodiment the image processing system 120 can be configured to output the bias signal prior to the commencement of imaging in order to charge up, or initialize, the bias circuitry 102. In this embodiment, the length of the initialization period can be as long as needed to charge the bias circuitry 102. Preferably, the bias circuitry 102 is designed to be low leakage so that once the proper DC bias voltage 310 is reached, minimal subsequent charging is needed.

[0034] FIG. 6 is a flow chart depicting a method 600 of operating the imaging device 110 with an image processing system 120 in an embodiment where communication channel 140 has only two signal lines available. At 604, the imaging device 110 is rotated to a first angular location. At 606, the image processing system 120 outputs a transducer drive signal 501 during a first time period to cause one or more CMUTs 101 to generate an ultrasound pulse. At 608, the image processing system 120 listens for any transducer output signals representative of the strength of an echo received by any CMUT 101 during a second time period. At 610, the image processing system 120 outputs a bias signal 504 during a third time period to charge the bias circuitry 102.

[0035] In addition, method 600 can also include an optional initialization process, referenced as 602, where the image processing system 120 can output bias signal 504 during a fourth time period, preferably in order to initialize the bias circuitry 102. Then, the method returns to step 604 and rotates to the next angular position and repeats steps 606-610. This process continues until imaging at all of the desired angular locations has taken place. The rotation of imaging device is preferably continuous but performed at such a rate where the rotation that occurs during the imaging cycle is negligible for the needs of the application.

[0036] In the foregoing specification, the invention has been described with reference to specific embodiments thereof. It will, however, be evident that various modifications and changes may be made thereto without departing from the scope of the invention as defined in the claims. For example, each feature of one embodiment can be mixed and matched with other features shown in other embodiments, and the sequence of steps shown in a flowchart may be changed. Features and processes known to those of ordinary skill may similarly be incorporated as desired. Additionally and obviously, features may be added or subtracted as desired. Accordingly, the invention is not to be restricted except in light of the attached claims and their equivalents.

Claims

1. A medical imaging system, comprising:

an imaging device (110) insertable into a living being and configured to image the interior of the living being, the imaging device comprising:

an ultrasound transducer (101, 202); and bias circuitry (102) electrically coupled with the ultrasound transducer (101, 202) and configured to electrically bias the ultrasound transducer; the imaging system further comprising

a rotatable driveshaft (108) coupled to the imaging device (110); and an image processing system (120) communicatively coupled with the imaging device (110), the image processing system (120) configured to output a transducer drive signal to the ultrasound transducer (101, 202) over a signal line located along the driveshaft (108),

characterized in that: the image processing system is coupled with the imaging device with an inductive coupling, and the image processing system is configured to provide charge to the bias circuitry (102) over the signal line.

2. The system of claim 1, wherein the transducer (101, 202) includes a micromachined ultrasound transducer (MUT).
3. The system of claim 2, wherein the transducer (101, 202) includes a capacitive micromachined ultrasound transducer (CMUT).
4. The system of claim 3, wherein the bias circuitry (102) is integrated with the CMUT (101, 202) on a common substrate (204).
5. The system of claim 4, wherein the substrate (204) is a semiconductor substrate.
6. The system of claim 1, wherein the bias circuitry (102) comprises a charge pump (406).
7. The system of claim 6, wherein the imaging device (101) comprises rectification circuitry (402).
8. The system of claim 1, wherein the bias circuitry (102) is configured to control the bias voltage.
9. The system of claim 8, wherein the bias circuitry (102) comprises charge limiting circuitry configured

to control the bias voltage.

10. The system of claim 4, wherein the transducer is one of a plurality of transducers within a transducer array. 5
11. The system of claim 1, wherein the image processing system (120) is configured to output a transducer drive signal (501) during a first time period, receive an echo signal during a second time period (502) and output a bias signal (504) during a third time period; and 10
wherein the transducer drive signal is configured to cause the ultrasound transducer (101,202) to generate an ultrasound pulse, the echo signal is representative of an echo received by the ultrasound transducer and the bias signal (504) is configured to provide electrical charge to the bias circuitry (102). 15
12. The system of claim 11, wherein the bias signal is a DC signal. 20
13. The system of claim 12, wherein the bias signal is a series of DC pulses.
14. The system of claim 13, wherein the amplitude of the bias signal is below an excitement threshold for the transducer. 25
15. The system of claim 11, wherein the image processing (120) system is further configured to output the bias signal during a fourth time period, longer than the third time period and prior to the first time period. 30
16. The system of claim 15, wherein the bias signal output during the fourth time period is configured to initialize the charge pump (406). 35

Patentansprüche

1. Medizinisches Abbildungssystem, welches aufweist:

eine Abbildungsvorrichtung (110), die in ein lebendes Wesen einführbar und ausgebildet ist, das Innere des lebenden Wesens abzubilden, welche Abbildungsvorrichtung aufweist: 45

einen Ultraschallwandler (101, 202); und eine Vorspannschaltung (102), die elektrisch mit dem Ultraschallwandler (101, 202) gekoppelt und ausgebildet ist, den Ultraschallwandler elektrisch vorzuspannen; welches Abbildungssystem weiterhin aufweist: 50

eine drehbare Antriebswelle (108), die mit der Abbildungsvorrichtung (110)

gekoppelt ist, und ein Bildverarbeitungssystem (120), das kommunikativ mit der Abbildungsvorrichtung (110) gekoppelt ist, welches Bildverarbeitungssystem (120) ausgebildet ist zum Ausgeben eines Wandlertreibersignals zu dem Ultraschallwandler (101, 202) über eine Signalleitung, die entlang der Antriebswelle (108) angeordnet ist, 10

dadurch gekennzeichnet, dass:

das Bildverarbeitungssystem mit der Abbildungsvorrichtung durch eine induktive Kopplung gekoppelt ist, und das Bildverarbeitungssystem ausgebildet ist zum Liefern von Ladung zu der Vorspannschaltung (102) über die Signalleitung. 15

2. System nach Anspruch 1, bei dem der Wandler (101, 202) einen mikrobearbeiteten Ultraschallwandler (MUT) enthält. 20
3. System nach Anspruch 2, bei dem der Wandler (101, 202) einen kapazitiven mikrobearbeiteten Ultraschallwandler (CMUT) enthält. 25
4. System nach Anspruch 3, bei dem die Vorspannschaltung (102) mit dem CMUT (101, 202) auf einem gemeinsamen Substrat (204) integriert ist. 30
5. System nach Anspruch 4, bei dem das Substrat (204) ein Halbleitersubstrat ist. 35
6. System nach Anspruch 1, bei dem die Vorspannschaltung (102) eine Ladungspumpe (406) aufweist. 40
7. System nach Anspruch 6, bei dem die Abbildungsvorrichtung (101) eine Gleichrichterschaltung (402) aufweist. 45
8. System nach Anspruch 1, bei dem Vorspannschaltung (102) ausgebildet ist zum Steuern der Vorspannung. 50
9. System nach Anspruch 8, bei dem die Vorspannschaltung (102) eine Ladungsbegrenzungsschaltung aufweist, die zum Steuern der Vorspannung ausgebildet ist. 55
10. System nach Anspruch 4, bei dem der Wandler einer von mehreren Wandlern innerhalb eines Wandlerfeldes ist.
11. System nach Anspruch 1, bei dem das Bildverarbeitungssystem (120) ausgebildet ist zum Ausgeben eines Wandlertreibersignals (501)

während einer ersten Zeitperiode, Empfangen eines Echosignals während einer zweiten Zeitperiode (502) und Ausgeben eines Vorspannsignals (504) während einer dritten Zeitperiode; und
 bei dem das Wandlertreibersignal ausgebildet ist zum Bewirken, dass der Ultraschallwandler (101, 202) einen Ultraschallimpuls erzeugt, wobei das Echosignal repräsentativ für ein durch den Ultraschallwandler empfangenes Echo ist und das Vorspannsignal (504) ausgebildet ist, elektrische Ladung zu der Vorspannschaltung (102) zu liefern.

12. System nach Anspruch 11, bei dem das Vorspannsignal ein Gleichstromsignal ist.
13. System nach Anspruch 12, bei dem das Vorspannsignal eine Reihe von Gleichstromimpulsen ist.
14. System nach Anspruch 13, bei dem die Amplitude des Vorspannsignals unterhalb einer Erregungsschwelle für den Wandler ist.
15. System nach Anspruch 11, bei dem das Bildverarbeitungssystem (120) weiterhin ausgebildet ist zum Ausgeben des Vorspannsignals während einer vierten Zeitperiode, die länger als die dritte Zeitperiode ist und vor der ersten Zeitperiode liegt.
16. System nach Anspruch 15, bei dem das während der vierten Zeitperiode ausgegebene Vorspannsignal ausgebildet ist zum Initialisieren der Ladungspumpe (406).

Revendications

1. Système d'imagerie médicale comprenant :

un dispositif d'imagerie (110) qui peut être inséré à l'intérieur d'un être vivant et qui est configuré pour imager l'intérieur de l'être vivant, le dispositif d'imagerie comprenant :

un transducteur à ultrasons (101, 202) ; et un circuit de polarisation (102) couplé électriquement au transducteur à ultrasons (101, 202) et configuré pour polariser électriquement le transducteur à ultrasons, le dispositif d'imagerie comprenant en outre :

un arbre d'entraînement pouvant tourner (108) couplé au dispositif d'imagerie (110) ; et

un système de traitement d'image (120) couplé en communication au dispositif d'imagerie (110), le système de traitement d'image (120) étant configuré pour émettre en sortie un signal de

pilotage de transducteur sur le transducteur à ultrasons (101, 202) sur une ligne de signal localisée le long de l'arbre d'entraînement (108),

caractérisé en ce que le système de traitement d'image est couplé au dispositif d'imagerie selon un couplage inductif et le système de traitement d'image est configuré pour appliquer une charge sur le circuit de polarisation (102) sur la ligne de signal.

2. Système selon la revendication 1, dans lequel le transducteur (101, 202) inclut un transducteur à ultrasons micro-usiné (MUT).
3. Système selon la revendication 2, dans lequel le transducteur (101, 202) inclut un transducteur à ultrasons micro-usiné capacitif (CMUT).
4. Système selon la revendication 3, dans lequel le circuit de polarisation (102) est intégré avec le CMUT (101, 202) sur un substrat commun (204).
5. Système selon la revendication 4, dans lequel le substrat (204) est un substrat semiconducteur.
6. Système selon la revendication 1, dans lequel le circuit de polarisation (102) comprend une pompe de charge (406).
7. Système selon la revendication 6, dans lequel le dispositif d'imagerie (101) comprend un circuit de redressement (402).
8. Système selon la revendication 1, dans lequel le circuit de polarisation (102) est configuré pour commander la tension de polarisation.
9. Système selon la revendication 8, dans lequel le circuit de polarisation (102) comprend un circuit de limitation de charge configuré pour commander la tension de polarisation.
10. Système selon la revendication 4, dans lequel le transducteur est l'un d'une pluralité de transducteurs à l'intérieur d'un réseau de transducteurs.
11. Système selon la revendication 1, dans lequel :
 le système de traitement d'image (120) est configuré pour émettre en sortie un signal de pilotage de transducteur (501) pendant une première période temporelle, pour recevoir un signal d'écho pendant une seconde période temporelle (502) et pour émettre en sortie un signal de polarisation (504) pendant une troisième période temporelle ; et dans lequel le signal de pilotage de transducteur est confi-

guré pour faire en sorte que le transducteur à ultrasons (101, 202) génère une impulsion ultrasonore, le signal d'écho est représentatif d'un écho reçu par le transducteur à ultrasons et le signal de polarisation (504) est configuré pour appliquer une charge électrique sur le circuit de polarisation (102). 5

12. Système selon la revendication 11, dans lequel le signal de polarisation est un signal DC. 10

13. Système selon la revendication 12, dans lequel le signal de polarisation est une série d'impulsions DC.

14. Système selon la revendication 13, dans lequel l'amplitude du signal de polarisation est au-dessous d'un seuil d'excitation pour le transducteur. 15

15. Système selon la revendication 11, dans lequel le système de traitement d'image (120) est en outre configuré pour émettre en sortie le signal de polarisation pendant une quatrième période temporelle plus longue que la troisième période temporelle et avant la première période temporelle. 20

16. Système selon la revendication 15, dans lequel le signal de polarisation émis en sortie pendant la quatrième période temporelle est configuré pour initialiser la pompe de charge (406). 25

30

35

40

45

50

55

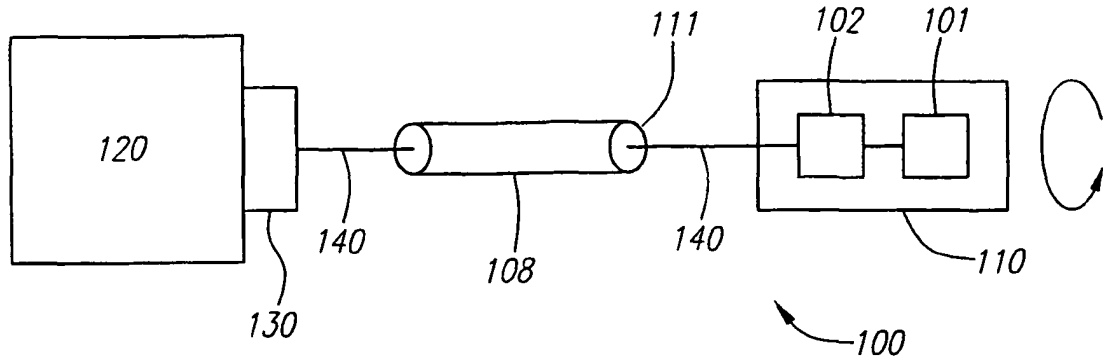

FIG. 1

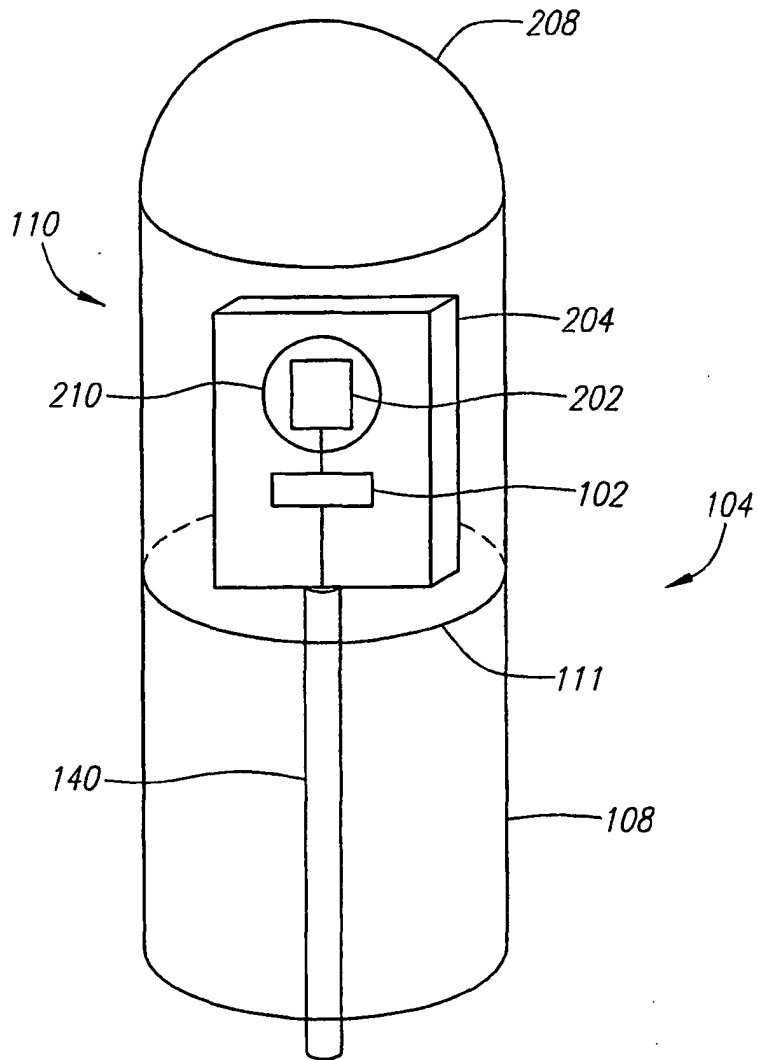

FIG. 2

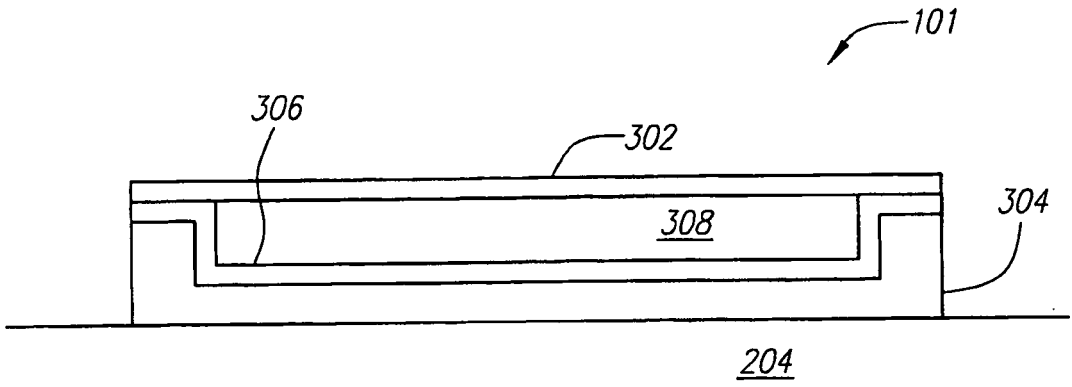

FIG. 3A

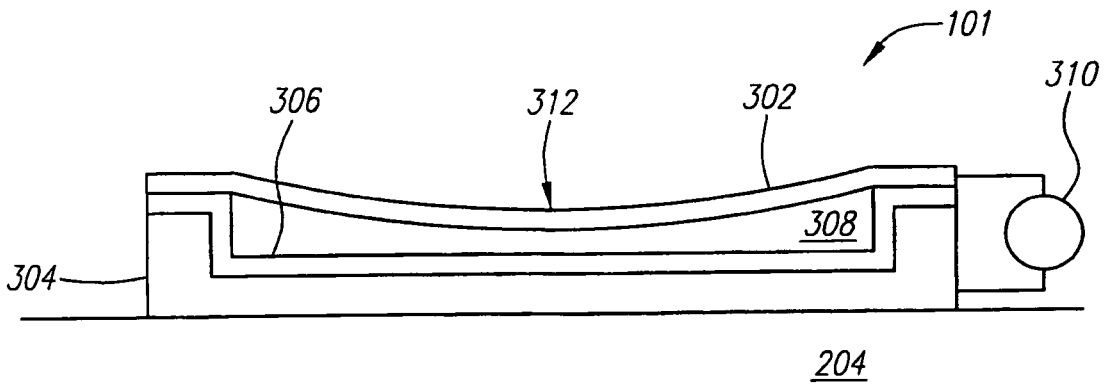

FIG. 3B

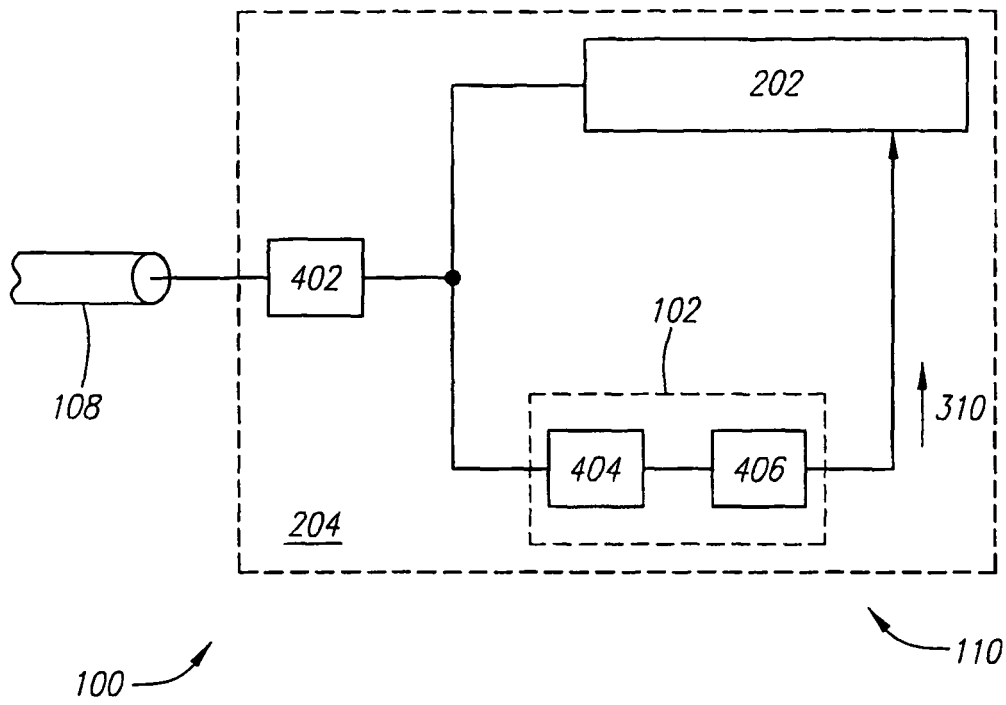

FIG. 4

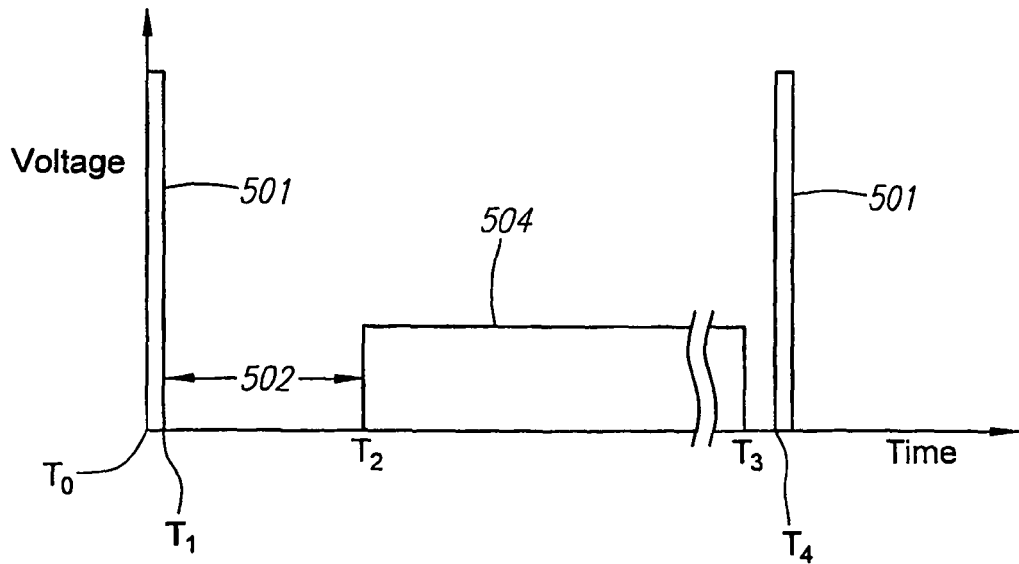

FIG. 5

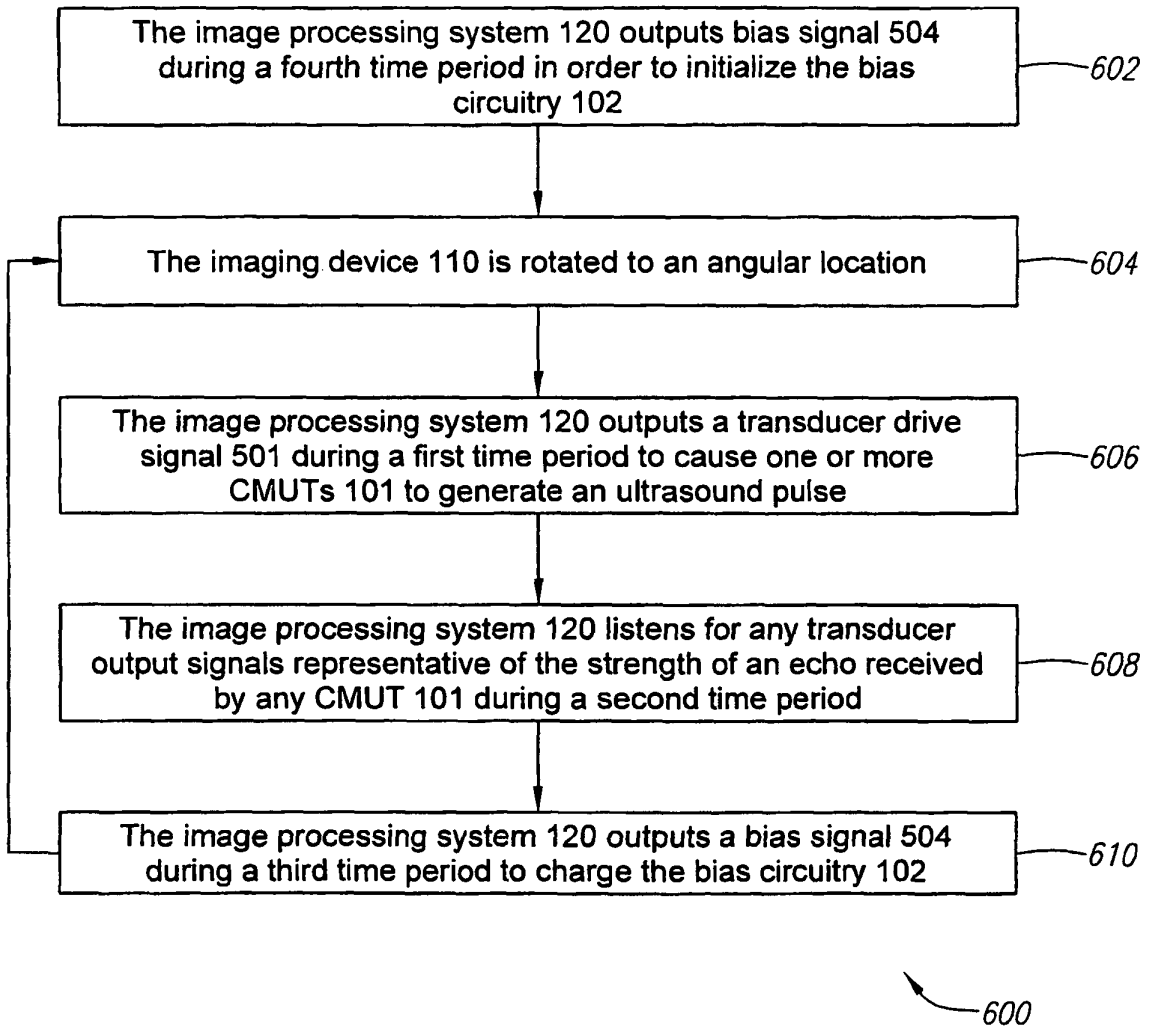

FIG. 6

REFERENCES CITED IN THE DESCRIPTION

This list of references cited by the applicant is for the reader's convenience only. It does not form part of the European patent document. Even though great care has been taken in compiling the references, errors or omissions cannot be excluded and the EPO disclaims all liability in this regard.

Patent documents cited in the description

- GB 2368123 A [0009]

Non-patent literature cited in the description

- **O. ORALKAN et al.** CMUT Ring Arrays for Forward-Looking Intravascular Imaging. *Ultrasonics Symposium, 2004 IEEE Montreal, 23 August 2004*, 403-406 [0007]
- **PERCIN, G. ; B. KHURI-YAKUB.** Piezoelectrically actuated flexensional micromachined ultrasound transducers. *Ultrasonics*, 2002, vol. 40 (1-8), 441-8 [0024]
- **PERCIN, G. ; B. KHURI-YAKUB.** Piezoelectrically actuated flexensional micromachined ultrasound transducers-II: fabrication and experiments. *IEEE Trans Ultrason Ferroelectr Freq Control*, 2002, vol. 49 (5), 585-95 [0024]
- **PERCIN, G. ; B. KHURI-YAKUB.** Piezoelectrically actuated flexensional micromachined ultrasound transducers-I: theory. *IEEE Trans Ultrason Ferroelectr Freq Control*, 2002, vol. 49 (5), 573-84 [0024]

专利名称(译)	用于超声成像设备的集成偏置电路		
公开(公告)号	EP1804673B1	公开(公告)日	2013-04-24
申请号	EP2005810279	申请日	2005-10-11
[标]申请(专利权)人(译)	波士顿科学有限公司		
申请(专利权)人(译)	BOSTON SCIENTIFIC LIMITED		
当前申请(专利权)人(译)	BOSTON SCIENTIFIC LIMITED		
[标]发明人	KNIGHT JON M		
发明人	KNIGHT, JON M.		
IPC分类号	A61B8/12		
CPC分类号	A61B8/12 B06B1/0292 G01S15/8906		
优先权	10/966594 2004-10-14 US		
其他公开文献	EP1804673A1		
外部链接	Espacenet		

摘要(译)

本文描述的系统和方法允许将偏压施加到在医学超声成像系统内实现的一个或多个换能器。偏置电路放置在成像装置内并用于将DC偏压施加到需要DC偏压来操作的一个或多个换能器。一个或多个换能器可以在半导体制造工艺中制造，并且与偏置电路集成在公共半导体衬底上。还提供了一种使用具有两条信号线的通信信道来操作一个或多个换能器和偏置电路的方法。

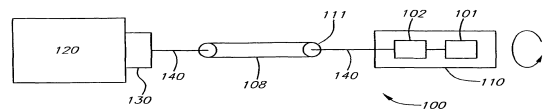

FIG. 1

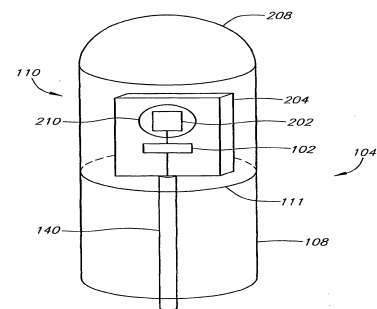

FIG. 2