

(19) World Intellectual Property  
Organization  
International Bureau



(43) International Publication Date  
6 January 2005 (06.01.2005)

PCT

(10) International Publication Number  
**WO 2005/000097 A2**

- (51) International Patent Classification<sup>7</sup>: **A61B**
- (21) International Application Number: PCT/US2004/018452
- (22) International Filing Date: 9 June 2004 (09.06.2004)
- (25) Filing Language: English
- (26) Publication Language: English
- (30) Priority Data: 60/477,532 10 June 2003 (10.06.2003) US
- (71) Applicant (for all designated States except US): **THE FOUNDRY, INC.** [US/US]; 199 Jefferson Drive, Menlo Park, CA 94025 (US).
- (72) Inventor; and
- (75) Inventor/Applicant (for US only): **GIFFORD, Hanson, S.** [US/US]; 3180 Woodside Road, Woodside, CA 94062 (US).
- (74) Agent: **HEISEY, David, E.**; Luce, Forward, Hamilton & Scripps LLP, 11988 El Camino Real, Suite 200, San Diego, CA 92130 (US).
- (81) Designated States (unless otherwise indicated, for every kind of national protection available): AE, AG, AL, AM, AT, AU, AZ, BA, BB, BG, BR, BW, BY, BZ, CA, CH, CN, CO, CR, CU, CZ, DE, DK, DM, DZ, EC, EE, EG, ES, FI, GB, GD, GE, GH, GM, HR, HU, ID, IL, IN, IS, JP, KE, KG, KP, KR, KZ, LC, LK, LR, LS, LT, LU, LV, MA, MD, MG, MK, MN, MW, MX, MZ, NA, NI, NO, NZ, OM, PG, PH, PL, PT, RO, RU, SC, SD, SE, SG, SK, SL, SY, TJ, TM, TN, TR, TT, TZ, UA, UG, US, UZ, VC, VN, YU, ZA, ZM, ZW.
- (84) Designated States (unless otherwise indicated, for every kind of regional protection available): ARIPO (BW, GH, GM, KE, LS, MW, MZ, NA, SD, SL, SZ, TZ, UG, ZM, ZW), Eurasian (AM, AZ, BY, KG, KZ, MD, RU, TJ, TM), European (AT, BE, BG, CH, CY, CZ, DE, DK, EE, ES, FI, FR, GB, GR, HU, IE, IT, LU, MC, NL, PL, PT, RO, SE, SI, SK, TR), OAPI (BF, BJ, CF, CG, CI, CM, GA, GN, GQ, GW, ML, MR, NE, SN, TD, TG).
- Published:**  
— without international search report and to be republished upon receipt of that report
- For two-letter codes and other abbreviations, refer to the "Guidance Notes on Codes and Abbreviations" appearing at the beginning of each regular issue of the PCT Gazette.



**WO 2005/000097 A2**

(54) Title: METHODS AND APPARATUS FOR NON-INVASIVELY TREATING ATRIAL FIBRILLATION USING HIGH INTENSITY FOCUSED ULTRASOUND

(57) Abstract: Methods and apparatus are provided that enable a physician to image tissue within the body that is to be ablated, and then to ablate that tissue using a device having an ultrasound imaging system and an aligned high intensity focused ultrasound system.

METHODS AND APPARATUS FOR NON-INVASIVELY TREATING ATRIAL  
FIBRILLATION USING HIGH INTENSITY FOCUSED ULTRASOUND

Field of the Invention

[0001] The present invention relates to methods and apparatus for treatment of atrial fibrillation, and more particularly, to the use of high intensity focused  
5 ultrasound non-invasively to disrupt abnormal cardiac electrical pathways contributing to atrial fibrillation.

Background of the Invention

[0002] Up until the 1980s, there was dramatic growth  
10 in the creation of new surgical methods for treating a wide variety of previously untreated conditions. Over the past twenty years there has been a clear trend towards the invention of devices and methods that enable less-invasive treatment of such diseases, moving from  
15 invasive surgery, and then to less-invasive surgery, and to interventional techniques. Ultimately, it is desirable to move to totally non-invasive therapies.

[0003] The history of treatment of atrial fibrillation has followed this progression. First, Dr. James Cox  
20 invented a new open-heart surgical procedure that interrupted depolarization waves using surgical incisions

in the walls of the atrium. More recently, a number of devices have been developed to allow surgeons to make such lesions during surgery on the beating heart, and without making incisions in the walls of the atrium.

5 More recently, interventional electrophysiologists have worked with companies to develop catheter-based systems to create similar lesions. Although only partial success has been achieved to date, there is optimism for further progress within the next few years.

10 [0004] It would be still more desirable to develop methods of treating atrial fibrillation which were still less invasive, eliminating even the need for catheters.

[0005] A wide variety of energy modes have been used to create lesions using epicardial or intracardiac  
15 probes. Radio-frequency electrical energy, microwaves, cryothermia probes, alcohol injection, laser light, and ultrasound energy are just a few of the technologies that have been pursued.

[0006] Separately, several groups have developed  
20 focused ultrasound devices with both imaging and therapeutic capabilities. These efforts began perhaps with lithotripsy, in which a high power focused ultrasound system developed by Dornier Medizintechnik, Germany, is used to break up kidney stones in the body.

25 The kidney stones are located within the body at a significant depth from the skin. One ultrasound imaging system is used to aim the system at the kidney stones, and then a second, high energy ultrasound system delivers energy that breaks up the stones so they can be passed.

30 [0007] More recently, Therus Corp of Seattle has developed a system to seal blood vessels after the vessels have been punctured to insert sheaths and catheters. The Therus system shrinks and seals femoral artery punctures at a depth of approximately 5 cm.

[0008] In addition, Timi-3 Systems, Inc. has developed and is testing a trans-thoracic ultrasound energy delivery system to accelerate the thrombolysis process for patients suffering an acute myocardial infarction.

5 This system delivers energy at a frequency intended to accelerate thrombolysis without damaging the myocardium or vasculature of the heart.

[0009] Epicor Medical, Inc. of Sunnyvale, CA, has developed a localized high intensity focused ultrasound ("HIFU") device to create lesions in the atrial walls.

10 The Epicor device is a hand-held intraoperative surgical device, and is configured to be held directly against the epicardium or outside wall of the heart. When energized, the device creates full-thickness lesions through the  
15 atrial wall of the heart, and has demonstrated that ultrasound energy may be safely and effectively used to create atrial lesions, despite presence of blood flow past the interior wall of the atrium.

[0010] In addition, Transurgical, Inc., Setauket, NY

20 has been actively developing HIFU devices. However, while the Epicor Medical devices are placed in close approximation against the outside of the heart, the Transurgical devices are directed to intravascular catheters for ablating tissue in the heart by bringing  
25 the catheter into close approximation with the targeted tissue.

[0011] In view of the aforementioned limitations, it would be desirable to provide methods and apparatus for treating atrial fibrillation and other conduction defects

30 by ablating tissue at a distance from that tissue, so that the procedure may be performed non-invasively.

[0012] It also would be desirable to provide methods and apparatus for treating atrial fibrillation by applying energy from outside the body or from organs,

such as the esophagus, that are easily accessible via natural body openings.

#### Summary of the Invention

5 [0013] In view of the foregoing, it is an object of the present invention to provide methods and apparatus for treating atrial fibrillation and other conduction defects by ablating tissue at a distance from that tissue, so that the procedure may be performed non-  
10 invasively.

[0014] It is another object of the present invention to provide methods and apparatus for treating cardiac dysfunction by applying energy from outside the body or from neighboring organs, such as the esophagus, that are  
15 easily accessible.

[0015] These and other objects of the present invention are accomplished by providing methods and apparatus that enable a physician to image tissue within the body that is to be ablated, and then to ablate that  
20 tissue using a completely or relatively non-invasive procedure, and with little or no anesthesia. Advantageously, the methods and apparatus of the present invention are expected to be cost-effective and time-efficient to perform compared to the previously-known  
25 surgical and interventional procedures.

#### Brief Description of the Drawings

[0016] The above and other objects and advantages of the present invention will be apparent upon consideration  
30 of the following detailed description, taken in conjunction with the accompanying drawings, in which like reference characters refer to like parts throughout, and in which:

[0017] FIG. 1 is a schematic view of an illustrative imaging and treatment ultrasound sound system of the present invention;

5 [0018] FIG. 2 is a schematic view of an illustrative display of the imaging and treatment ultrasound sound system of the present invention;

[0019] FIG. 3 is a schematic view showing the imaging and treatment ultrasound sound system of FIG. 1 disposed adjacent to a cross-section of a patient's thorax; and

10 [0020] FIG. 4 is a schematic view of the distal region of a catheter-based high intensity focused ultrasound array.

#### Detailed Description of the Invention

15 [0021] The present invention is directed to methods and apparatus for creating lesions in the walls of the heart in a completely non-invasive manner using high intensity focused ultrasound (HIFU). Previously-known HIFU systems, such as those being developed by Epicor  
20 Medical or Transurgical, require close approximation of the HIFU device to the target tissue. The methods and apparatus of the present invention overcome this drawback by providing a system that enables the creation of lesions in the heart wall from a greater distance.

25 [0022] Referring to FIG. 1, apparatus constructed in accordance with the principles of the present invention is described. System 10 comprises head 11 housing ultrasound imaging system 12 and high intensity focused ultrasound energy ("HIFU") system 14. Ultrasound imaging  
30 system 12 and HIFU system 14 may have in common all or just a subset of the transducers and related components, operating in different modes to image or ablate. Head 11 is mounted on arm 13 that permits the head to be positioned in contact with a patient (not shown) lying on

table 15. Head 11 may also be a handheld unit, not needing an arm 13 to support or position it. System 10 includes controller 16 that controls operation of imaging system 12 and HIFU system 14. Monitor 18 displays images  
5 output by imaging system 12 that allows the clinician to identify the desired locations on the walls of the heart to be treated.

[0023] In accordance with the methods of the present invention, controller 16 and monitor 18 also are  
10 programmed to indicate the focus of the HIFU energy relative to the image of the tissue cross-section. FIG. 2 is illustrative screen display 19 of monitor 18 showing the outline **T** of the tissue, as imaged by imaging system 12, and a marker corresponding to the location of focal  
15 point **F** of HIFU system 14.

[0024] When activated, the HIFU system delivers ablative energy to the specific location shown on monitor 18 (focal point **F** in FIG. 2), thus enabling safe creation of transmural lesions. Because the HIFU system is  
20 configured to deliver energy from a number of sources focused towards the target tissue area, intervening tissue is subjected to only a fraction of the energy deposited in the target tissue receives, and thus the intervening tissue is not significantly heated or  
25 ablated.

[0025] Still referring to FIG. 1, ultrasound imaging system 12 may be similar in design to previously-known trans-thoracic ultrasound imaging systems, and are per se known. High intensity focused ultrasound system 14 may  
30 comprise one or more HIFU generators 20 constructed as described in U.S. Patent Application No. US20010031922A1. As mentioned before, imaging system 12 and HIFU system 14 may also use the same elements. Preferably, each HIFU generator 20 is the same as or is disposed approximately

in the same plane as the imaging elements of ultrasound imaging system 12, so that the focus of HIFU system 14 occurs in the plane of the target tissue imaged by ultrasound imaging system 12. In addition, this arrangement advantageously ensures that the HIFU energy will reach the target.

5 [0026] In a preferred embodiment, HIFU generators 20 deliver energy at a frequency optimized for creating lesions in myocardium, to thereby interrupt conduction pathways through the tissue without reducing the strength of the tissue. Once the lesions are created, a gradual healing process is begun in which the lesions fibrose, but do not fall apart or regain the ability to conduct electrical impulses.

10 [0027] While it may be possible to image and ablate simultaneously, it is possible that the output of HIFU system 14 may block the ability to image the tissue using ultrasound imaging system 12. Accordingly, controller 16 may be programmed to time-gate operation of imaging system 12 and HIFU system 14, so that the tissue is alternately imaged and ablated at a frequency of several times per second.

15 [0028] In order to create linear lesions in the wall of the atria of the heart, it may be desirable to slowly move the focus of the HIFU system along the wall of the atrium during the ablation process. While this may be accomplished by manually moving the HIFU system, for example, for treating relatively short lesions that encircle each or all of the pulmonary veins. Controller 20 . 16 may include suitable programming and joystick 22, or other input device, for refocusing the focal point of HIFU system 14 along a desired trajectory.

[0029] Referring now to FIG. 3, a further alternative for using HIFU system to create linear lesions is

described. In the system shown in FIG. 3 the focus of the HIFU system is fixed at a certain point within the field of the ultrasound image. For example, the ultrasound image might show a picture of rectangular  
5 planar cross-section of tissue approximately 80 mm wide and 160 mm deep, with a fixed focus of the HIFU energy at a depth of 130 mm in the center of the field.

[0030] In operation, the clinician manually moves the probe until the desired tissue is in the target area, and  
10 then fires the HIFU system to ablate the tissue. With such a system the depth of maximal ablation is 130 mm below the skin. In order to ablate tissue located less than 130 mm below the skin and still retain a continuous fluid path from the probe to the target, the HIFU system  
15 includes fluid-filled balloon 24 that covers the face of the probe.

[0031] Balloon 24 preferably is filled with water and enables the clinician to reposition the probe at a variable distance from the skin. Balloon 24 also permits  
20 the clinician to position the probe at any desired angle to target tissue not aligned directly under the focal point of HIFU system 14. Alternatively, the patient could sit in a tub of water, so the patient's chest and the probe were both underwater, again ensuring a  
25 continuous fluid path.

[0032] As a further alternative, controller 16 may be programmed so that the depth of the focal point of the HIFU system is depth-adjustable relative to the imaged tissue. Advantageously, the depth of the targeted tissue  
30 could then be adjusted relative to the imaged field, so a smaller fluid-filled balloon, or no balloon, is used to maintain fluid contact while adjusting the angle of the imaged section or make minor changes in the depth of the targeted tissue. WIPO Patent Publication No.

WO/0145550A2 to Therus describes several ways to adjust the depth of the focused energy by changing the radius of curvature of one or more of the ultrasound generators.

Alternatively, the direction of several focused energy  
5 generators of relatively fixed focal length could be shifted relative to one another to move the focal point.

[0033] In accordance with the principles of the present invention, focused energy is applied from outside the patient's body. Because ultrasound energy does not  
10 travel coherently through non-fluid filled tissue, such as the lungs, positioning of the ultrasound imaging system and HIFU system at certain angles may be more advantageous for treatment of specific areas of the heart. For example, the posterior wall of the left  
15 atrium is a particularly important treatment area for treating atrial fibrillation; it is also a peculiarly difficult area to image with trans-thoracic ultrasound.

[0034] Accordingly, it may be desirable to locate the imaging system and HIFU system on a movable arm or to  
20 position it by hand so as to permit other external approaches, such as from below the diaphragm on the left anterior side of the body, so the ultrasound has a coherent path through the diaphragm and apex and ventricles of the heart to the atria. Application of the  
25 probe to a patient's back also may provide a coherent path to the posterior wall of the patient's left atrium.

[0035] It is expected that the system and methods of the present invention also may be useful for treating a number of cardiac dysfunctions. Apart from treatment of  
30 atrial fibrillation, the methods and apparatus of the present invention also may be used to treat other electrophysiologic defects of the heart, or to create lesions for other purposes. For example, if transmyocardial revascularization (TMR) is believed to

have a positive effect on damaged ventricles by causing focal areas of damage and healing, such lesions may be created non-invasively using the present invention.

[0036] As another example, localized tissue damage and the consequent healing process may cause the septum primum and septum secundum of a patent foramen ovale (PFO) to heal together, closing the PFO. If the system and methods of present invention are effective in closing PFO even a small percentage of the time, the non-invasive nature of the procedure might have it the first choice for use an initial therapy in most cases.

[0037] In addition, the HIFU system described hereinabove also may be used to repair diseased heart valves, by shrinking tissue in certain areas. For example, specific areas of elongated chordae of a mitral valve leaflet may be shortened by heating using the external HIFU of the present invention.

[0038] While in the preferred embodiment described hereinabove energy is delivered from outside the body, situations may arise where it is difficult to deliver the energy to locations deep inside the body or locations adjacent to the lungs or other non-ultrasound-conductive tissue.

[0039] Referring now to FIG. 4, and in accordance with another aspect of the present invention, methods and apparatus are provided for positioning a probe inside the body and closer to the targeted tissue, but still not necessarily adjacent to it. Intraluminal probe 30 is configured to deliver HIFU energy to the heart from the esophagus, from the aorta, or from the great veins of the heart such as the inferior vena cava, superior vena cava, or the right atrium itself.

[0040] This approach is fundamentally different from previously-known methods of performing ablation during

surgical procedures using epicardial probes or during interventional procedures using intracardiac ablation catheters. These previously-known devices are designed to be in direct contact or at least very close proximity  
5 (e.g., within 5 mm) of the target tissue, and are not designed to avoid ablation of intervening tissue between the probe and the target tissue.

[0041] In addition, previously-known devices are capable of making only a single lesion from a given  
10 position, rather than forming a number of lesions at a distance from a device from a single location. Making multiple lesions from a single catheter position advantageously may save time and reduce the cost of the procedure. For example, approximating a surgical maze  
15 procedure using previously-known intracardiac catheters typically takes from four to eight hours, and subject both the patient and physician to high levels of radiation from the fluoroscope. By contrast, a device constructed in accordance with the principles of the  
20 present invention, under ultrasound imaging guidance, could create multiple lesions while disposed at a single position in the esophagus, aorta, or great veins or right atrium.

[0042] Still referring to FIG. 4, intraluminal  
25 catheter 30 is designed to image and deliver HIFU energy from body lumens such as the esophagus, aorta, and great veins. Catheter 30 preferably has a diameter in a range of 5 to 10 mm for vascular devices, and a diameter in a range of 5 to 20 mm for an esophageal device. Imaging  
30 elements 32 and HIFU elements 34 are arranged linearly along the longitudinal axis of the catheter.

[0043] The linear nature of the imaging element and HIFU element array may impose limitations on the ability to reposition the device. While translation and rotation

of the catheter may be relatively easy, it is contemplated that it may be difficult to move the device very far to one side or another within a relatively small-diameter body lumen.

5 [0044] Accordingly, intraluminal catheter 30 preferably is configured to adjust the focal point of the HIFU system with respect to both longitudinal position and depth. This may be accomplished by programming the controller used with intraluminal catheter 30 to adjust  
10 the focal point of the HIFU system, as described above. Alternatively, refocusing of the array of HIFU elements may be achieved by locating individual HIFU elements on independently steerable actuators 36. Actuators 36 are controlled by the system controller and permit the  
15 clinician to move the focal point of the HIFU array to any desired point in the field of view of the imaging system.

[0045] In accordance with another aspect of the present invention, methods of using intraluminal catheter  
20 30 to perform ablation from the esophagus to treat atrial fibrillation are described. The esophagus is separated from the center of the posterior left atrial wall only by the oblique pericardial sinus, so a linear vertical lesion may be easily made in the center of the posterior  
25 left atrial wall using a probe capable of delivering energy at a distance of approximately 5 - 10 mm.

[0046] Such methods are believed to offer substantial advantages with respect to ease of use, and may be effective in treating a high percentage of atrial  
30 fibrillation patients. These methods also may obviate the need to contract significant areas of the posterior wall of the left atrium, as typically happens when broad encircling lesions are made around the pulmonary veins.

[0047] In accordance with this aspect of the present invention, one or more vertical ablation lines are formed in the posterior wall of the left atrium using intraluminal catheter 30 disposed within the esophagus.

5 It is expected that formation of straight ablation lines vertically in the posterior wall of the atrium, under ultrasound imaging guidance from the esophagus, may also be easier than making encircling ablation lines around the pulmonary veins.

10 [0048] The foregoing methods of creating lesions are consistent with the underlying concept of the maze procedure as invented by Dr. James Cox in the early 1990s. His research in mapping the depolarization waves in patients with atrial fibrillation showed that  
15 dysfunction arose from waves recirculating around the atria. This recirculation is enabled by slightly damaged tissue, which slows the progress of the depolarization wave, and enlargement of the atria due to damage, valve dysfunction, or congestive heart failure.

20 [0049] The maze concept relies on the creation of numerous dead-end pathways in the atria, so the depolarization wave reaches all of the atrial walls, but cannot recirculate. A series of vertical ablation lines in the posterior wall of the left atrium, extending from  
25 the atrioventricular groove up to above the superior pulmonary veins would accomplish exactly this goal.

[0050] Preferably, the ablation lines extend all the way down to the atrioventricular groove. This allows the depolarization wave to reach that tissue from the dome of  
30 the left atrium (the more cranial and anterior surface) but not to progress back to the rest of the atrial wall along the atrioventricular groove.

[0051] As described above, intraluminal catheter 30 preferably is configured, either mechanically or by

suitable software algorithms, to move its focal point longitudinally to enable a continuous linear ablation without moving the device. Alternatively, the HIFU array of the catheter may be configured to create a linear  
5 ablation, or have a fixed-focus so that a linear ablation may be created by translating the HIFU array within the esophagus.

[0052] Further in accordance with the present invention, additional lesions may be made closer to the  
10 left and right pulmonary veins. More preferably, lesions could be made on the opposite sides of the left and right pulmonary veins, i.e., to the left of the left pulmonary veins and to the right of the right pulmonary veins. Alternatively, and depending on the geometry of the HIFU  
15 probe, it may be more desirable to make encircling lesions in the left and right pulmonary veins using the same vertical motion.

[0053] In addition, it may be beneficial to cool tissue surrounding the HIFU array of intraluminal  
20 catheter 30, to further reduce the risk of damage to the esophagus. Intraluminal catheter 30 may therefore include a water jacket that circulated fluid around the HIFU array to prevent any heat generated by the array or ultrasound energy absorbed by the esophagus from causing  
25 any tissue damage.

[0054] The methods and apparatus of the present invention also may be beneficially applied to other applications besides cardiac dysfunction. For example, the apparatus of the present invention may be used,  
30 disposed in small body lumens, nearly anywhere a radiofrequency ablation probe is currently being used to ablate or shrink tissue. Such treatments include treating the prostate from the urethra, tightening up the bladder neck from inside the vagina, ablating fibroid

masses from inside the uterus, tightening up the tissue in the area of the gastroesophageal junction, and so on. Likewise, the external device described with respect to FIG. 1 may be beneficially used to ablate tumors almost  
5 anywhere in the body that is accessible to focused ultrasound.

[0055] Although preferred illustrative embodiments of the present invention are described above, it will be evident to one skilled in the art that various changes  
10 and modifications may be made without departing from the invention. It is intended in the appended claims to cover all such changes and modifications that fall within the true spirit and scope of the invention.

What is claimed is:

1. Apparatus for non-invasively treating atrial fibrillation comprising:
  - a housing;
  - an ultrasound imaging system disposed within the housing;
  - a high intensity focused ultrasound system disposed within the housing in alignment with the ultrasound imaging system; and
  - a controller operably connected to the ultrasound imaging system and high intensity focused ultrasound system.
2. The apparatus of claim 1 wherein the controller ultrasound imaging system and the high intensity focused ultrasound system comprise common transducers.
3. The apparatus of claim 1 wherein the controller is programmed to display a marker corresponding to a focal point of the high intensity focused ultrasound system.
4. The apparatus of claim 3 wherein the controller is programmed to adjust a location of the focal point of the high intensity focused ultrasound system within a two-dimensional plane orthogonal to an axis of the high intensity focused ultrasound system.
5. The apparatus of claim 3 wherein the controller is programmed to adjust a location of a depth of the focal point of the high intensity focused ultrasound system.

6. The apparatus of claim 1 further comprising a fluid-filled balloon coupled to the housing to adjust a location of the focal point of the high intensity focused ultrasound system.

7. A method of non-invasively treating atrial fibrillation comprising:

providing a housing having an ultrasound imaging system and a high intensity focused ultrasound system disposed in alignment with the ultrasound imaging system;

contacting the housing against a patient's body;

operating the ultrasound imaging system to generate an image of a portion of cardiac tissue; and

operating the high intensity focused ultrasound system, guided by the image, to ablate cardiac tissue at a target site.

8. The method of claim 7 further comprising generating and displaying a marker corresponding to a focal point of the high intensity focused ultrasound system on the image.

9. The method of claim 7 further comprising modifying a location of the target site by adjusting a location of the focal point of the high intensity focused ultrasound system.

10. The method of claim 7 further comprising ablating cardiac tissue along a series of vertical ablation lines on a wall of the patient's left atrium.

11. The method of claim 7 further comprising disposing a fluid-filled balloon between the patient's body and the housing to adjust a location of the focal point of the high intensity focused ultrasound system.

12. Apparatus for intraluminally treating atrial fibrillation comprising:

a catheter;

an ultrasound imaging system disposed within the catheter;

a high intensity focused ultrasound system disposed within the catheter in alignment with the ultrasound imaging system; and

a controller operably connected to the ultrasound imaging system and high intensity focused ultrasound system.

13. The apparatus of claim 12 wherein the controller ultrasound imaging system and the high intensity focused ultrasound system comprise common components.

14. The apparatus of claim 12 wherein the controller is programmed to display a marker corresponding to a focal point of the high intensity focused ultrasound system.

15. The apparatus of claim 14 wherein the controller is programmed to adjust a location of the focal point of the high intensity focused ultrasound system within a two-dimensional plane orthogonal to an axis of the high intensity focused ultrasound system.

16. The apparatus of claim 14 wherein the controller is programmed to adjust a location of a depth of the focal point of the high intensity focused ultrasound system.

17. The apparatus of claim 12 wherein the high intensity focused ultrasound system is configured to focus along a linear ablation target.

18. A method of intraluminally treating atrial fibrillation comprising:

providing a catheter having a distal portion housing an ultrasound imaging system and a high intensity focused ultrasound system disposed in alignment with the ultrasound imaging system;

disposing the distal portion of the catheter within a patient's body esophagus;

operating the ultrasound imaging system to generate an image of a portion of cardiac tissue; and

operating the high intensity focused ultrasound system, guided by the image, to ablate of cardiac tissue at a target site.

19. The method of claim 18 further comprising generating and displaying a marker corresponding to a focal point of the high intensity focused ultrasound system on the image.

20. The method of claim 18 further comprising modifying a location of the target site by adjusting a location of the focal point of the high intensity focused ultrasound system.

21. The method of claim 18 further comprising ablating cardiac tissue along a series of vertical ablation lines on a posterior wall of the patient's left atrium.

22. The method of claim 18 further comprising disposing ablating cardiac tissue with the high intensity focused ultrasound system along a linear ablation target.

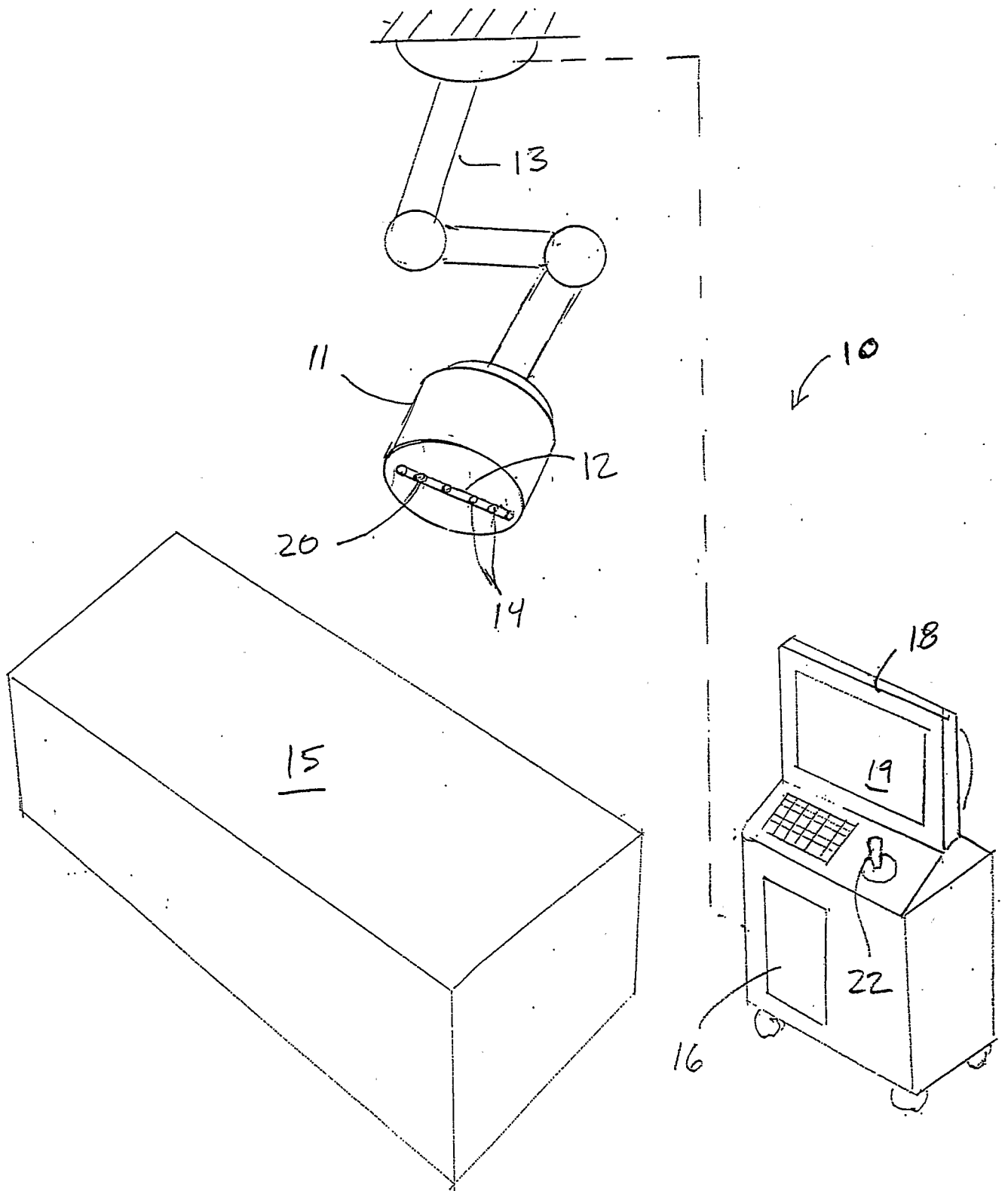

FIG. 1

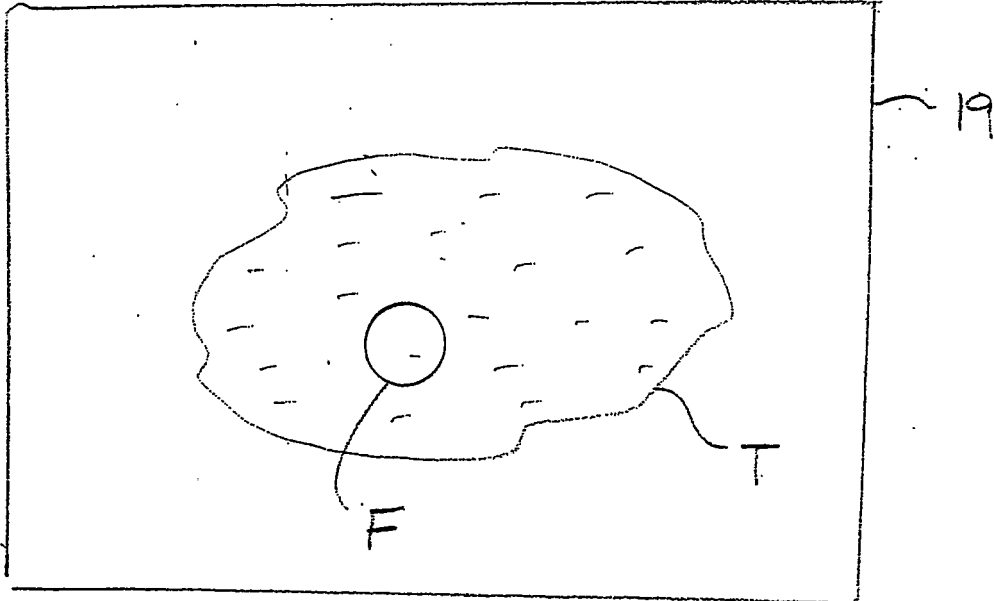

FIG. 2

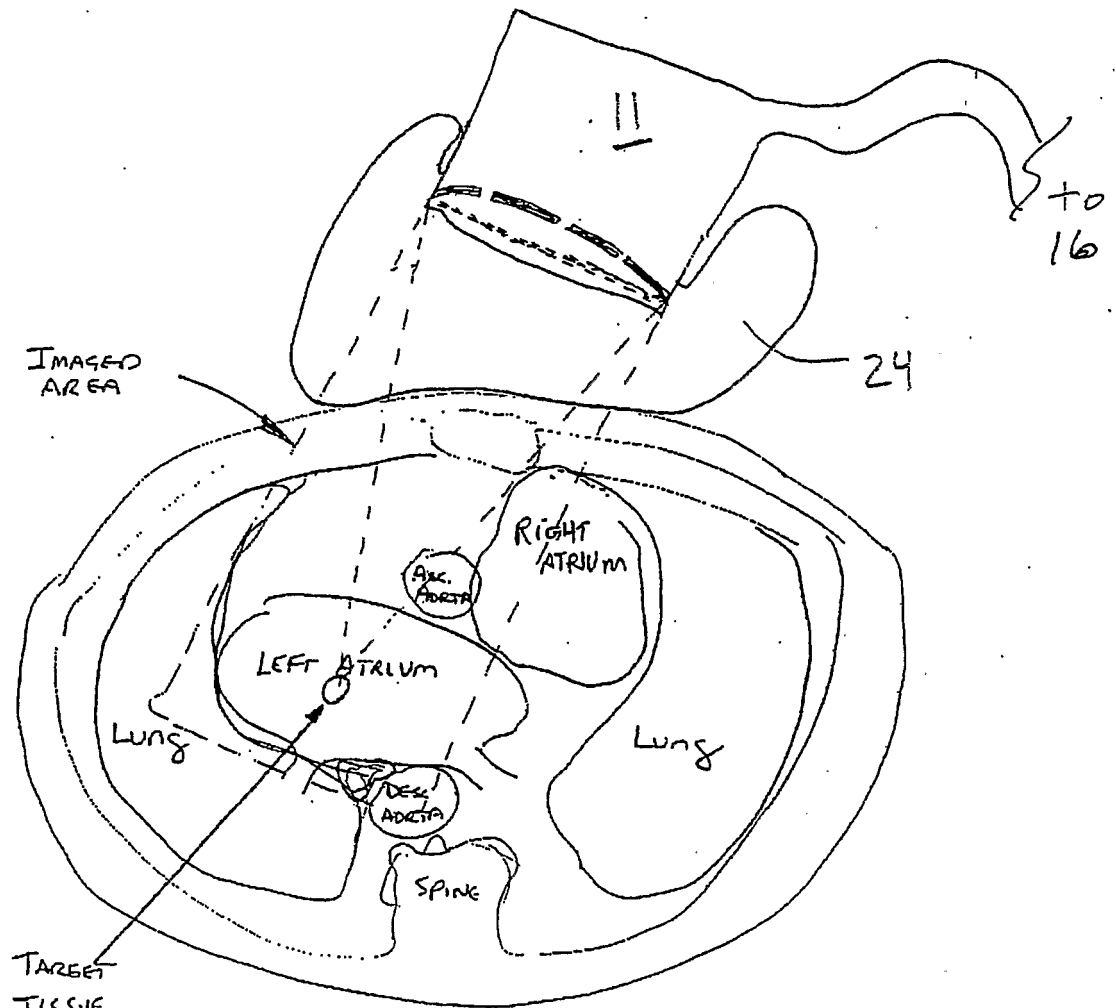
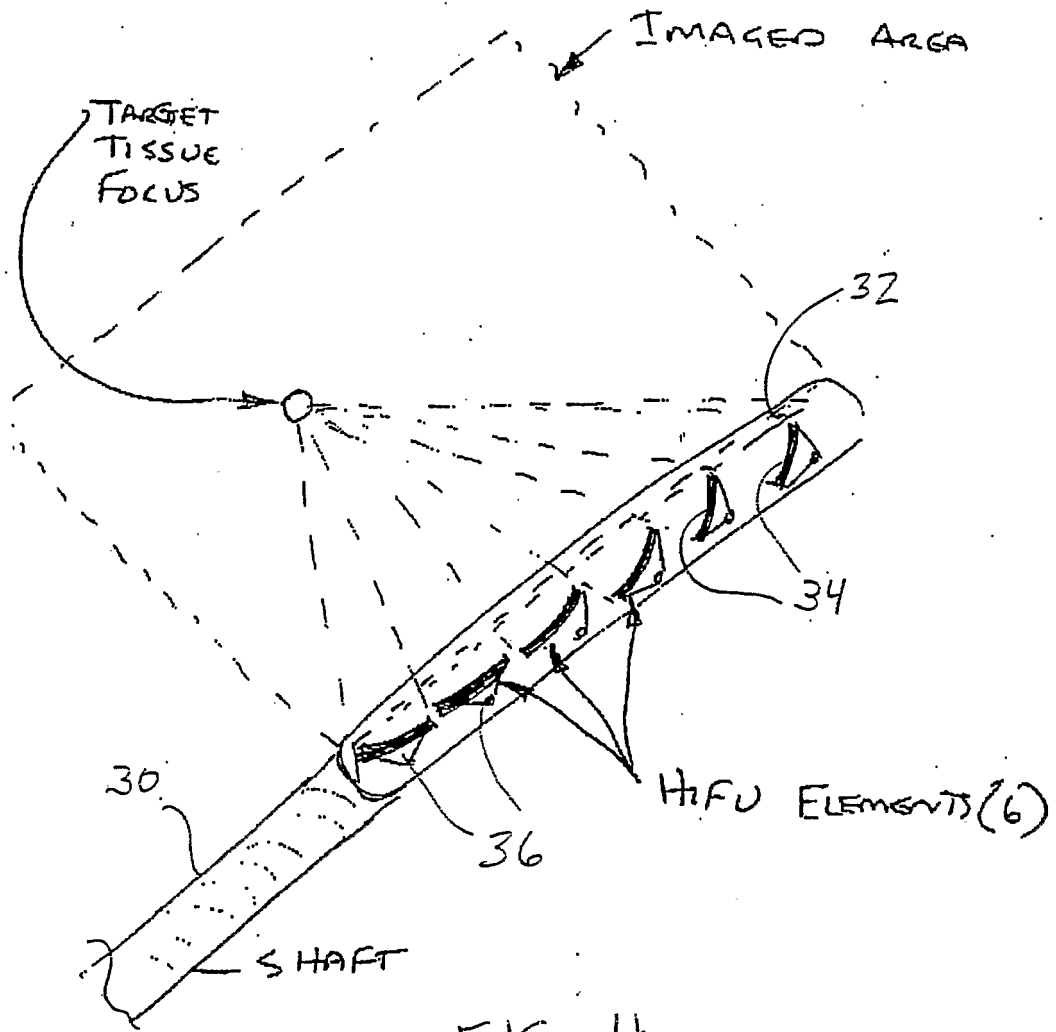

FIG. 3



专利名称(译)	使用高强度聚焦超声非侵入性地治疗心房颤动的方法和设备		
公开(公告)号	<a href="#">EP1633266A2</a>	公开(公告)日	2006-03-15
申请号	EP2004754905	申请日	2004-06-09
[标]申请(专利权)人(译)	铸造公司		
申请(专利权)人(译)	代工, INC.		
当前申请(专利权)人(译)	铸造有限责任公司		
[标]发明人	GIFFORD HANSON S		
发明人	GIFFORD, HANSON, S.		
IPC分类号	A61B18/18 A61N7/02 A61B A61B8/12 A61B17/00 A61B18/04 A61B90/00 A61N7/00		
CPC分类号	A61N7/02 A61B8/0883 A61B8/12 A61B8/4488 A61B2017/00243 A61B2018/00351 A61B2090/3782 A61N2007/0078		
代理机构(译)	法思博事务所		
优先权	60/477532 2003-06-10 US		
其他公开文献	EP1633266A4 EP1633266B1		
外部链接	<a href="#">Espacenet</a>		

#### 摘要(译)

提供了方法和设备, 其使得医生能够对要被消融的身体内的组织成像, 然后使用具有超声成像系统和对准的高强度聚焦超声系统的设备来消融该组织。