

(19)



(11)

**EP 3 495 054 A3**

(12)

**EUROPEAN PATENT APPLICATION**

(88) Date of publication A3:  
**10.07.2019 Bulletin 2019/28**

(51) Int Cl.:  
**B06B 1/02 (2006.01)**      **A61B 8/00 (2006.01)**  
**A61B 5/00 (2006.01)**

(43) Date of publication A2:  
**12.06.2019 Bulletin 2019/24**

(21) Application number: **18207458.3**

(22) Date of filing: **21.11.2018**

(84) Designated Contracting States:  
**AL AT BE BG CH CY CZ DE DK EE ES FI FR GB GR HR HU IE IS IT LI LT LU LV MC MK MT NL NO PL PT RO RS SE SI SK SM TR**  
 Designated Extension States:  
**BA ME**  
 Designated Validation States:  
**KH MA MD TN**

- **MACHIDA, Shuntaro**  
Tokyo, Aichi 100-8280 (JP)
- **HASEGAWA, Hiroaki**  
Tokyo, Aichi 100-8280 (JP)
- **TANAKA, Tomohiko**  
Tokyo, Aichi 100-8280 (JP)
- **IMAI, Ryo**  
Tokyo, 100-8280 (JP)
- **SEO, Yoshiho**  
Tokyo, 100-8280 (JP)
- **MATSUDA, Takahiro**  
Tokyo, 100-8280 (JP)
- **ONOE, Shinsuke**  
Tokyo, 100-8280 (JP)

(30) Priority: **04.12.2017 JP 2017232365**

(71) Applicant: **Hitachi, Ltd.**  
**Tokyo 100-8280 (JP)**

(72) Inventors:  
 • **TAKEZAKI, Taiichi**  
**Tokyo, Aichi 100-8280 (JP)**

(74) Representative: **Strehl Schübel-Hopf & Partner**  
**Maximilianstrasse 54**  
**80538 München (DE)**

**(54) ULTRASOUND IMAGING PROBE, MANUFACTURING METHOD THEREOF, AND ULTRASONIC IMAGING DEVICE**

(57) An ultrasound imaging probe capable of securing an assembly accuracy of and improving a resolution performance of an obtained image is provided.

A photoacoustic catheter 5 includes: a silicon substrate 5a which includes an ultrasonic transducer 5b for detecting an ultrasonic wave formed thereon and a through hole 5c passing through front and rear surfaces;

an optical fiber 5d which oscillates a laser 7; a lens 5e which condenses the laser 7 and is arranged within the through hole 5c; a tubular housing 5f; a glass cover 5i which covers the lens 5e; and a resin 5g which fills a gap 10 between the through hole 5c and the lens 5e. Further, the silicon substrate 5a and the optical fiber 5d are fixed to a part of the housing 5f in the housing 5f.

[FIG. 2]

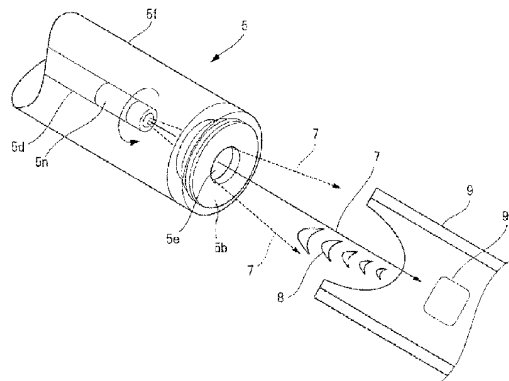

**EP 3 495 054 A3**



EUROPEAN SEARCH REPORT

Application Number  
EP 18 20 7458

5

10

15

20

25

30

35

40

45

50

55

DOCUMENTS CONSIDERED TO BE RELEVANT			
Category	Citation of document with indication, where appropriate, of relevant passages	Relevant to claim	CLASSIFICATION OF THE APPLICATION (IPC)
X	CN 103 969 192 A (UNIV JIANGXI NORMAL SCI & TECH) 6 August 2014 (2014-08-06) * figures 1-3 * * paragraphs [0014], [0016], [0018] - [0020] *	1-14	INV. B06B1/02 A61B8/00 A61B5/00
A	----- US 2007/287912 A1 (KHURI-YAKUB BUTRUS T [US] ET AL) 13 December 2007 (2007-12-13) * the whole document *	1-14	
A	----- US 2008/221448 A1 (KHURI-YAKUB BUTRUS T [US] ET AL) 11 September 2008 (2008-09-11) * the whole document *	1-14	
A	----- WO 2012/131577 A2 (KONINKL PHILIPS ELECTRONICS NV [NL]; RADULESCU EMIL GEORGE [US] ET AL.) 4 October 2012 (2012-10-04) * the whole document *	1-14	
			TECHNICAL FIELDS SEARCHED (IPC)
			B06B A61B
The present search report has been drawn up for all claims			
Place of search The Hague		Date of completion of the search 28 May 2019	Examiner Parmentier, Hélène
CATEGORY OF CITED DOCUMENTS X : particularly relevant if taken alone Y : particularly relevant if combined with another document of the same category A : technological background O : non-written disclosure P : intermediate document T : theory or principle underlying the invention E : earlier patent document, but published on, or after the filing date D : document cited in the application L : document cited for other reasons ..... & : member of the same patent family, corresponding document			

1  
EPO FORM 1503 03.82 (P04C01)

ANNEX TO THE EUROPEAN SEARCH REPORT  
ON EUROPEAN PATENT APPLICATION NO.

EP 18 20 7458

5

This annex lists the patent family members relating to the patent documents cited in the above-mentioned European search report. The members are as contained in the European Patent Office EDP file on The European Patent Office is in no way liable for these particulars which are merely given for the purpose of information.

28-05-2019

10

Patent document cited in search report	Publication date	Patent family member(s)	Publication date
CN 103969192 A	06-08-2014	NONE	
US 2007287912 A1	13-12-2007	NONE	
US 2008221448 A1	11-09-2008	NONE	
WO 2012131577 A2	04-10-2012	CN 103458816 A EP 2691041 A2 JP 6185906 B2 JP 2014509547 A US 2014088418 A1 WO 2012131577 A2	18-12-2013 05-02-2014 23-08-2017 21-04-2014 27-03-2014 04-10-2012

15

20

25

30

35

40

45

50

55

EPO FORM P0459

For more details about this annex : see Official Journal of the European Patent Office, No. 12/82

专利名称(译)	超声成像探头，其制造方法和超声成像装置		
公开(公告)号	<a href="#">EP3495054A3</a>	公开(公告)日	2019-07-10
申请号	EP2018207458	申请日	2018-11-21
[标]申请(专利权)人(译)	株式会社日立制作所		
申请(专利权)人(译)	HITACHI, LTD.		
当前申请(专利权)人(译)	HITACHI, LTD.		
[标]发明人	TAKEZAKI TAIICHI MACHIDA SHUNTARO HASEGAWA HIROAKI TANAKA TOMOHIKO IMAI RYO SEO YOSHIHO MATSUDA TAKAHIRO ONOE SHINSUKE		
发明人	TAKEZAKI, TAIICHI MACHIDA, SHUNTARO HASEGAWA, HIROAKI TANAKA, TOMOHIKO IMAI, RYO SEO, YOSHIHO MATSUDA, TAKAHIRO ONOE, SHINSUKE		
IPC分类号	B06B1/02 A61B8/00 A61B5/00		
CPC分类号	A61B5/0095 A61B5/6852 A61B5/6876 A61B8/12 A61B8/445 B06B1/0292		
优先权	2017232365 2017-12-04 JP		
其他公开文献	EP3495054A2		
外部链接	<a href="#">Espacenet</a>		

摘要(译)

提供了一种能够确保所获得图像的组装精度并改善其分辨率性能的超声成像探头。光声导管5包括：硅基板5a，其包括用于检测在其上形成的超声波的超声换能器5b和穿过前表面和后表面的通孔5c；光纤5d振荡激光器7；透镜5e，其聚光激光器7并设置在通孔5c内；管状壳体5f；覆盖透镜5e的玻璃盖5i；树脂5g填充通孔5c和透镜5e之间的间隙10。此外，硅衬底5a和光纤5d固定到壳体5f中的壳体5f的一部分。

[FIG. 2]

