



(11) **EP 2 289 452 A3**

(12) **EUROPEAN PATENT APPLICATION**

(88) Date of publication A3:
30.12.2015 Bulletin 2015/53

(51) Int Cl.:
A61B 19/00 (2006.01) A61B 8/00 (2006.01)
A61B 8/12 (2006.01)

(43) Date of publication A2:
02.03.2011 Bulletin 2011/09

(21) Application number: **11150207.6**

(22) Date of filing: **05.06.2006**

(84) Designated Contracting States:
AT BE BG CH CY CZ DE DK EE ES FI FR GB GR HU IE IS IT LI LT LU LV MC NL PL PT RO SE SI SK TR

(72) Inventors:

- **Hasser, Christopher**
Sunnyvale, CA 94086 (US)
- **Taylor, Russell**
Baltimore, MD 21218 (US)
- **Choti, Michael**
Baltimore, MD 21218 (US)
- **Leven, Josh**
Baltimore, MD 21218 (US)

(30) Priority: **06.06.2005 US 688013 P**

(62) Document number(s) of the earlier application(s) in accordance with Art. 76 EPC:
06784595.8 / 1 887 961

(74) Representative: **MacDougall, Alan John Shaw**
Mathys & Squire LLP
The Shard
32 London Bridge Street
London SE1 9SG (GB)

(71) Applicant: **Intuitive Surgical Operations, Inc.**
Sunnyvale, CA 94086 (US)

(54) **Laparoscopic ultrasound robotic surgical system**

(57) A LUS robotic surgical system is trainable by a surgeon to automatically move a LUS probe in a desired fashion upon command so that the surgeon does not have to do so manually during a minimally invasive surgical procedure. A sequence of 2D ultrasound image slices captured by the LUS probe according to stored instructions are processable into a 3D ultrasound computer model of an anatomic structure, which may be displayed as a 3D or 2D overlay to a camera view or in a PIP as selected by the surgeon or programmed to assist the surgeon in inspecting an anatomic structure for abnormalities. Virtual fixtures are definable so as to assist the surgeon in accurately guiding a tool to a target on the displayed ultrasound image.

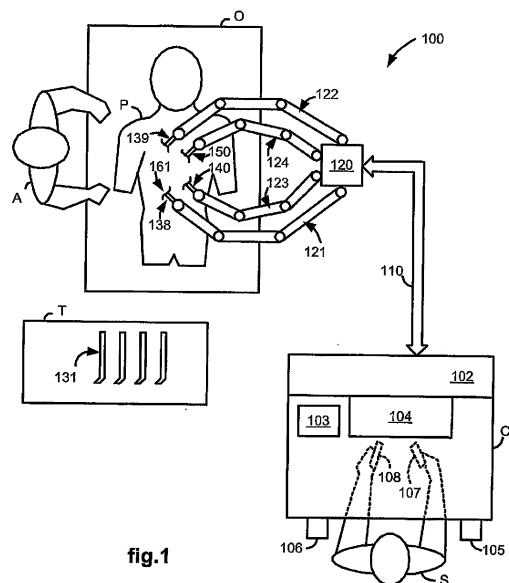

fig.1

EP 2 289 452 A3



EUROPEAN SEARCH REPORT

Application Number
EP 11 15 0207

5

10

15

20

25

30

35

40

45

50

55

DOCUMENTS CONSIDERED TO BE RELEVANT			
Category	Citation of document with indication, where appropriate, of relevant passages	Relevant to claim	CLASSIFICATION OF THE APPLICATION (IPC)
X	US 6 425 865 B1 (SALCUDEAN SEPTIMIU E [CA] ET AL) 30 July 2002 (2002-07-30) * column 11, line 22 - line 38; figure 1 * -----	1-11	INV. A61B19/00 A61B8/00 A61B8/12
A	US 2001/037064 A1 (SHAHIDI RAMIN [US]) 1 November 2001 (2001-11-01) * abstract; figure 1 * -----	1-11	
A	US 2005/085718 A1 (SHAHIDI RAMIN [US]) 21 April 2005 (2005-04-21) * paragraphs [0024], [0051], [0052]; figure 4 * -----	1-11	
The present search report has been drawn up for all claims			TECHNICAL FIELDS SEARCHED (IPC)
			A61B
Place of search		Date of completion of the search	Examiner
The Hague		24 November 2015	Mayer-Martenson, E
CATEGORY OF CITED DOCUMENTS			
X : particularly relevant if taken alone Y : particularly relevant if combined with another document of the same category A : technological background O : non-written disclosure P : intermediate document		T : theory or principle underlying the invention E : earlier patent document, but published on, or after the filing date D : document cited in the application L : document cited for other reasons & : member of the same patent family, corresponding document	

EPO FORM 1503 03.82 (P04C01)

**ANNEX TO THE EUROPEAN SEARCH REPORT
ON EUROPEAN PATENT APPLICATION NO.**

EP 11 15 0207

5

This annex lists the patent family members relating to the patent documents cited in the above-mentioned European search report. The members are as contained in the European Patent Office EDP file on The European Patent Office is in no way liable for these particulars which are merely given for the purpose of information.

10

24-11-2015

15

20

25

30

35

40

45

50

55

Patent document cited in search report	Publication date	Patent family member(s)	Publication date
US 6425865	B1	30-07-2002	NONE

US 2001037064	A1	01-11-2001	AU 4323701 A 03-09-2001
			US 2001025183 A1 27-09-2001
			US 2001037064 A1 01-11-2001
			US 2004010190 A1 15-01-2004
			WO 0162173 A2 30-08-2001

US 2005085718	A1	21-04-2005	NONE

EPO FORM P0459

For more details about this annex : see Official Journal of the European Patent Office, No. 12/82

专利名称(译)	腹腔镜超声机器人手术系统		
公开(公告)号	EP2289452A3	公开(公告)日	2015-12-30
申请号	EP2011150207	申请日	2006-06-05
[标]申请(专利权)人(译)	直观外科手术操作公司		
申请(专利权)人(译)	Intuitive Surgical公司运营, INC.		
当前申请(专利权)人(译)	Intuitive Surgical公司运营, INC.		
[标]发明人	HASSER CHRISTOPHER TAYLOR RUSSELL CHOTI MICHAEL LEVEN JOSH		
发明人	HASSER, CHRISTOPHER TAYLOR, RUSSELL CHOTI, MICHAEL LEVEN, JOSH		
IPC分类号	A61B19/00 A61B8/00 A61B8/12		
CPC分类号	A61B8/00 A61B8/12 A61B8/4218 A61B8/4245 A61B34/25 A61B34/30 A61B34/37 A61B34/70 A61B34/76 A61B90/03 A61B90/361 A61B2017/00203 A61B2034/107 A61B2090/364 A61B2090/365 A61B2090/378 A61B1/3132 A61B8/461 A61B90/37 A61B2034/305		
优先权	60/688013 2005-06-06 US		
其他公开文献	EP2289452A2		
外部链接	Espacenet		

摘要(译)

LUS机器人手术系统可由外科医生训练, 以在命令时以期望的方式自动移动LUS探针, 使得外科医生在微创外科手术期间不必手动操作。由LUS探针根据存储的指令捕获的2D超声图像切片序列可处理成解剖结构的3D超声计算机模型, 其可以显示为相机视图的3D或2D覆盖或者通过选择的PIP显示。外科医生或编程以协助外科医生检查解剖结构的异常情况。虚拟固定装置是可定义的, 以便帮助外科医生将工具准确地引导到所显示的超声图像上的目标。

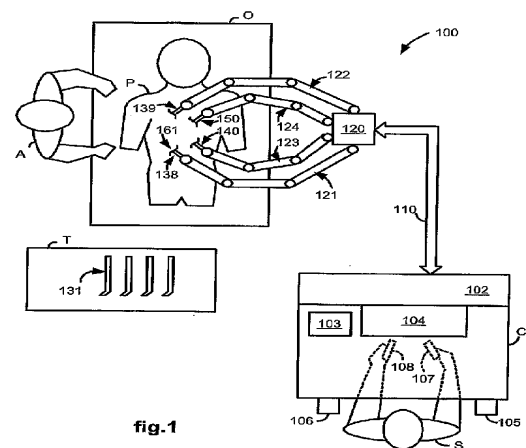

fig. 1