



(11) **EP 1 873 719 A2**

(12) **EUROPEAN PATENT APPLICATION**

(43) Date of publication:
02.01.2008 Bulletin 2008/01

(51) Int Cl.:
G06T 7/20 (2006.01) **G06T 15/00** (2006.01)
A61B 8/00 (2006.01)

(21) Application number: **07008042.9**

(22) Date of filing: **20.04.2007**

(84) Designated Contracting States:
AT BE BG CH CY CZ DE DK EE ES FI FR GB GR HU IE IS IT LI LT LU LV MC MT NL PL PT RO SE SI SK TR
Designated Extension States:
AL BA HR MK YU

(72) Inventor: **Shin, Seong Chul**
Seoul 135-280 (KR)

(74) Representative: **Lorenz, Werner**
Lorenz & Kollegen
Patent- und Rechtsanwaltskanzlei
Alte Ulmer Strasse 2-4
89522 Heidenheim (DE)

(30) Priority: **26.06.2006 KR 20060057585**

(71) Applicant: **MEDISON CO., LTD.**
Kangwon-do 250-870 (KR)

(54) **Apparatus and method for displaying an ultrasound image**

(57) Embodiments of the present invention may provide an apparatus and a method of displaying a 3-dimensional ultrasound image formed based on 2-dimensional ultrasound images in an ultrasound diagnostic system. The method of displaying an ultrasound image in an ultrasound diagnostic system, comprises: a) forming a plurality of sequential 2-dimensional ultrasound images based on ultrasound echo signals reflected from a predetermined region of a target object; b) compensating for motions occurring between the 2-dimensional ultrasound images; c) selecting a predetermined number of

consecutive 2-dimensional ultrasound images from the motion-compensated 2-dimensional ultrasound images; d) superposing the selected 2-dimensional ultrasound images to form a 3-dimensional ultrasound image; e) setting at least one line on the 3-dimensional ultrasound image and cutting the 3-dimensional ultrasound image along the line to obtain a plurality of cutting planes; f) selecting one cutting plane from the cutting planes; and g) rendering the selected cutting plane and displaying the rendered cutting plane.

EP 1 873 719 A2

Description

[0001] The present application claims priority from Korean Patent Application No. 10-2006-0057585 filed on June 26, 2006, the entire subject matter of which is incorporated herein by reference.

BACKGROUND

1. Field

[0002] The present invention generally relates to ultrasound image processing, and more particularly to an apparatus and method for displaying a 3-dimensional ultrasound image formed by superposing a plurality of 2-dimensional ultrasound images.

2. Background

[0003] An ultrasound diagnostic system has become an important and popular diagnostic tool since it has a wide range of applications. Specifically, due to its non-invasive and non-destructive nature, the ultrasound diagnostic system has been extensively used in the medical profession. Modern high-performance ultrasound diagnostic systems and techniques are commonly used to produce two or three-dimensional diagnostic images of internal features of an object (e.g., human organs).

[0004] The ultrasound diagnostic system generally uses a wide bandwidth transducer to transmit and receive ultrasound signals. The ultrasound diagnostic system forms images of human internal tissues by electrically exciting an acoustic transducer element or an array of acoustic transducer elements to generate ultrasound signals that travel into the body. The ultrasound signals produce ultrasound echo signals since they are reflected from body tissues, which appear as discontinuities to the propagating ultrasound signals. Various ultrasound echo signals return to the transducer element and are converted into electrical signals, which are amplified and processed to produce ultrasound data for an image of the tissues. The ultrasound diagnostic system is very important in the medical field since it provides physicians with real-time and high-resolution images of human internal features without the need for invasive observation techniques such as surgery.

[0005] Generally, the ultrasound diagnostic system obtains raw 3D data (e.g., data on a coordinate system (x, y, z)) through a 3D probe by stacking consecutive frames. It then processes the consecutive frames using a 3D rendering technique, thereby producing static 3D images. By using the static 3D images for ultrasound diagnostic purposes, one may easily and accurately observe, diagnose and treat the internal state of a human body without performing any complicated procedures associated with invasive operations. Thus, the static 3D images are widely used. However, the static 3D images are not useful in observing a moving target object in real

time such as a heart or a fetus in the uterus.

[0006] In order to overcome this shortcoming, a live 3D imaging method and apparatus for providing a live 3D moving image (rather than static 3D images) have been developed. However, it is impossible to scan the entire motion of a heart by using a 3-dimensional probe for live 3D imaging due to the limitations in hardware capability. Therefore, there is a problem in that a change in motion at a specific region of the heart cannot be observed in real time. Also, the 3-dimensional probe for forming a live 3D ultrasound image is disadvantageous since it is very complex and expensive.

[0007] Accordingly, there is a clear need in the art for forming a 3-dimensional ultrasound image in real time without using a 3-dimensional probe.

BRIEF DESCRIPTION OF THE DRAWINGS

[0008] Arrangements and embodiments may be described in detail with reference to the following drawings in which like reference numerals refer to like elements and wherein:

[0009] FIG. 1 is a block diagram showing an ultrasound diagnostic system constructed in accordance with the present invention;

[0010] FIG. 2 is a schematic diagram showing a method of compensating for motion of a target object;

[0011] FIG. 3 is a flowchart illustrating a method of displaying an ultrasound image in accordance with one embodiment of the present invention;

[0012] FIG. 4 is a schematic diagram illustrating a plurality of 2-dimensional ultrasound images formed based on ultrasound echo signals reflected from a predetermined region of a target object;

[0013] FIG. 5 is a schematic diagram illustrating a 3-dimensional ultrasound image formed by superposing a plurality of 2-dimensional ultrasound images;

[0014] FIG. 6 is a schematic diagram showing a 3-dimensional ultrasound image formed by superposing a plurality of 2-dimensional ultrasound images when motion is compensated; and

[0015] FIG. 7 is a schematic diagram showing an example of setting a straight line on the 3-dimensional ultrasound image illustrated in FIG. 6.

DETAILED DESCRIPTION

[0016] A detailed description may be provided with reference to the accompanying drawings. One of ordinary skill in the art may realize that the following description is illustrative only and is not in any way limiting. Other embodiments of the present invention may readily suggest themselves to such skilled persons having the benefit of this disclosure.

[0017] FIG. 1 is a block diagram showing an ultrasound diagnostic system constructed in accordance with the present invention. As shown in FIG. 1, the ultrasound diagnostic system 100 includes a probe 110, a 2-dimen-

sional ultrasound image forming unit 120, a motion compensating unit 130, a 3-dimensional ultrasound image forming unit 140, a display unit 150 and a marker setting unit 160. The probe 110 transmits ultrasound signals to a target object and receives ultrasound echo signals. The probe 110 may be any probe capable of acquiring a 2-dimensional ultrasound image.

[0018] The 2-dimensional ultrasound image forming unit 120 forms a plurality of 2-dimensional ultrasound images having serial numbers based on the ultrasound echo signals reflected from a predetermined region of a target object. The 2-dimensional ultrasound images may be one of B-mode images, Doppler images and color-mode images. The serial number may be set in an order of acquisition time of the 2-dimensional ultrasound images.

[0019] The motion compensating unit 130 compensates for motions occurring between the 2-dimensional ultrasound images due to the trembling of the hands and the like. In order to compensate for the motion in the 2-dimensional ultrasound images, the motion in the 2-dimensional ultrasound images is estimated and then the estimated motion is compensated. The motion estimation may be implemented by using block matching algorithm in accordance with one embodiment of the present invention. As shown in FIG. 2, the motion compensating unit 130 partitions a motion region 220 set on a current frame 210 into a plurality of reference blocks 214. Also, the motion compensating unit 130 sets a search region 222 on a previous frame 220. The motion compensation unit 130 compares pixels included in each reference block with pixels included in the search region 222, thereby searching a region having pixels in the search region, which is closest to the pixels of the reference block (hereinafter referred to as an optimal region). The motion compensation unit 130 sets a position of the optimal region as a motion vector 216 on the reference block. The motion compensating unit 130 compensates for the motion based on the motion vector 216. In accordance with another embodiment of the present invention, a pixel recursive (PR) motion estimating method or an optical flow motion estimating method may be alternatively adopted for motion estimation.

[0020] The 3-dimensional ultrasound image forming unit 140 forms a 3-dimensional ultrasound image based on the plurality of 2-dimensional ultrasound images, the motions of which are compensated in the motion compensating unit 130. The 3-dimensional ultrasound image forming unit 140 selects a predetermined number of 2-dimensional ultrasound images in accordance with one embodiment of the present invention. The selected 2-dimensional ultrasound images are sequentially buffered and then superposed, thereby forming the 3-dimensional ultrasound image. Also, the 3-dimensional ultrasound image forming unit 140 may individually render the selected 2-dimensional ultrasound images and can then superpose them in order to form the 3-dimensional ultrasound image.

[0021] In accordance with another embodiment of the present invention, the 3-dimensional ultrasound image forming unit 140 may set a region of interest (ROI) in each 2-dimensional ultrasound images and then extract the images included in the ROIs. The 3-dimensional ultrasound image forming unit 140 can superpose the extracted images, thereby forming the 3-dimensional ultrasound image.

[0022] The 3-dimensional ultrasound image forming unit 140 may provide a transparent 3-dimensional ultrasound image obtained by an appropriate transparency treatment for showing a volume of interest (VOI) in the 3-dimensional ultrasound image. The 3-dimensional ultrasound image or the transparent 3-dimensional ultrasound image formed in the 3-dimensional ultrasound image forming unit 140 is transmitted to the display unit and then displayed on a screen of the display unit 150.

[0023] The cutting plane selecting unit 160 receives a line setting instruction from a user and sets at least one line on the 3-dimensional ultrasound image displayed on the display unit 150 in response to the line setting instruction. The line setting instruction may be inputted by using a control key (not denoted) provided in the ultrasound diagnostic system to set an arbitrary line on the 3-dimensional ultrasound image. The cutting plane selecting unit 160 cuts the 3-dimensional ultrasound image along the line in a depth direction and then selects one of the cutting planes. The selected plane is rendered, wherein the rendered plane image is then displayed on the display unit 150. A plurality of lines may be set on the 3-dimensional ultrasound image and the rendering of the cutting plane may be performed by using an anti-aliasing technique.

[0024] Hereinafter, a method of displaying an ultrasound image will be described in detail with reference to FIGS. 3 to 6. FIG. 3 is a flowchart illustrating a method of displaying the ultrasound image in accordance with one embodiment of the present invention.

[0025] Referring to FIG. 2, the 2-dimensional ultrasound image forming unit 120 forms a plurality of 2-dimensional ultrasound images in real time based on the ultrasound echo signals, which are reflected from a predetermined region of a target object, as shown in FIG. 3 at step S310. Serial numbers P_1 - P_{n+m} may be assigned to each 2-dimensional ultrasound image. The serial numbers assigned to the 2-dimensional ultrasound images may be set in the order of acquisition time of the 2-dimensional ultrasound images. The motion compensating unit 130 estimates the motions occurring between the 2-dimensional ultrasound images formed in the 2-dimensional ultrasound image forming unit 120 and then compensates for the estimated motions at step S320.

[0026] The 3-dimensional ultrasound image forming unit 140 selects a predetermined number of 2-dimensional ultrasound images having consecutive serial numbers among the 2-dimensional ultrasound images in which the motions are compensated at step S330. The selected 2-dimensional ultrasound images are superposed to thereby form a 3-dimensional ultrasound image at step S340.

The 3-dimensional ultrasound image is displayed on the display unit 150 at step S350. Thereafter, at least one line is set on the displayed 3-dimensional ultrasound image and then one cutting plane obtained by cutting the 3-dimensional ultrasound image in a depth direction is selected at step S360. The selected cutting plane is displayed on the display unit 150 at step S370. The cutting plane may be rendered by using the anti-aliasing technique and then displayed on the display unit 150.

[0027] FIG. 5 is a schematic diagram showing a 3-dimensional ultrasound image formed by superposing 2-dimensional ultrasound images acquired from a target object when the motion occurs. FIG. 6 is a schematic diagram showing a 3-dimensional ultrasound image formed by superposing 2-dimensional ultrasound images when the motion of the target object is compensated in accordance with one embodiment of the present invention.

[0028] FIG. 7 is a schematic diagram showing an example of setting a straight line on the 3-dimensional ultrasound image illustrated in FIG. 6. As shown in FIG. 7, the straight line 700 may be set on a desirable portion in the 3-dimensional ultrasound image. The 3-dimensional ultrasound image is then cut along the straight line in a depth direction. One of the cutting planes may be selected, wherein the selected cutting plane is rendered. The rendered plane is then displayed on the display unit 150.

[0029] As mentioned above, the 3-dimensional ultrasound image is formed by superposing the 2-dimensional ultrasound images in accordance with one embodiment of the present invention. As such, the 3-dimensional ultrasound image can be provided without using an expensive 3-dimensional probe.

[0030] Also, since the straight line can be set on the 3-dimensional ultrasound image formed by superposing the 2-dimensional ultrasound images when the motion of the target object is compensated in accordance with the present invention, the user can see the display plane in the 3-dimensional ultrasound image even if the motion occurs in acquiring the 2-dimensional ultrasound images.

[0031] A method of displaying an ultrasound image in an ultrasound diagnostic system, comprises: a) forming a plurality of sequential 2-dimensional ultrasound images based on ultrasound echo signals reflected from a predetermined region of a target object; b) compensating for motions occurring between the 2-dimensional ultrasound images; c) selecting a predetermined number of consecutive 2-dimensional ultrasound images from the motion-compensated 2-dimensional ultrasound images; d) superposing the selected 2-dimensional ultrasound images to form a 3-dimensional ultrasound image; e) setting at least one line on the 3-dimensional ultrasound image and cutting the 3-dimensional ultrasound image along the line to obtain a plurality of cutting planes; f) selecting one cutting plane from the cutting planes; and g) rendering the selected cutting plane and displaying the rendered cutting plane.

[0032] An apparatus of displaying an ultrasound image

in an ultrasound diagnostic system, comprises: a probe for transmitting ultrasound signals into a target object and receiving ultrasound echo signals; a 2-dimensional ultrasound image forming unit for forming a plurality of 2-dimensional ultrasound images based on the ultrasound image signals reflected from a predetermined region of a target object; a motion compensating unit for compensating motions occurring between the 2-dimensional ultrasound images; a 3-dimensional ultrasound image forming unit for selecting a predetermined number of consecutive 2-dimensional ultrasound images from the motion-compensated 2-dimensional ultrasound images, and superposing the selected 2-dimensional ultrasound images to thereby form a 3-dimensional ultrasound image; a cutting plane selecting unit for setting at least one line on the 3-dimensional ultrasound image and cutting the 3-dimensional ultrasound image along the line to obtain a plurality of cutting planes, wherein the cutting plane selecting unit selects one cutting plane from the cutting planes; and a displaying unit for displaying the 3-dimensional ultrasound image and the cutting plane.

[0033] Any reference in this specification to "one embodiment," "an embodiment," "example embodiment," etc., means that a particular feature, structure or characteristic described in connection with the embodiment is included in at least one embodiment of the invention. The appearances of such phrases in various places in the specification are not necessarily all referring to the same embodiment. Further, when a particular feature, structure or characteristic is described in connection with any embodiment, it is submitted that it is within the purview of one skilled in the art to effect such feature, structure or characteristic in connection with other ones of the embodiments.

[0034] Although embodiments have been described with reference to a number of illustrative embodiments thereof, it should be understood that numerous other modifications and embodiments can be devised by those skilled in the art that will fall within the spirit and scope of the principles of this disclosure. More particularly, numerous variations and modifications are possible in the component parts and/or arrangements of the subject combination arrangement within the scope of the disclosure, the drawings and the appended claims. In addition to variations and modifications in the component parts and/or arrangements, alternative uses will also be apparent to those skilled in the art.

Claims

1. A method of displaying an ultrasound image in an ultrasound diagnostic system, comprising:

a) forming a plurality of sequential 2-dimensional ultrasound images based on ultrasound echo signals reflected from a predetermined region of a target object;

- b) compensating for motions occurring between the 2-dimensional ultrasound images;
- c) selecting a predetermined number of consecutive 2-dimensional ultrasound images from the motion-compensated 2-dimensional ultrasound images; 5
- d) superposing the selected 2-dimensional ultrasound images to form a 3-dimensional ultrasound image;
- e) setting at least one line on the 3-dimensional ultrasound image and cutting the 3-dimensional ultrasound image along the line to obtain a plurality of cutting planes; 10
- f) selecting one cutting plane from the cutting planes; and 15
- g) rendering the selected cutting plane and displaying the rendered cutting plane.
- 2.** The method of Claim 1, wherein the motion compensation is carried out by using one of a block matching motion estimating method, a pel recursive (PR) motion estimating method and an optical flow motion estimating method. 20
- 3.** The method of Claim 1, wherein the step d) includes: 25
- d1) setting a region of interest (ROI) on each selected 2-dimensional ultrasound image;
- d2) extracting 2-dimensional ultrasound images included in the ROIs; and 30
- d3) superposing the extracted 2-dimensional images to form the 3-dimensional ultrasound image.
- 4.** The method of Claim 1, wherein the line is a straight line. 35
- 5.** The method of Claim 1, wherein the rendering is carried out by using an anti-aliasing technique. 40
- 6.** An apparatus of displaying an ultrasound image in an ultrasound diagnostic system, comprising:
- a probe for transmitting ultrasound signals into a target object and receiving ultrasound echo signals; 45
- a 2-dimensional ultrasound image forming unit for forming a plurality of 2-dimensional ultrasound images based on the ultrasound image signals reflected from a predetermined region of a target object; 50
- a motion compensating unit for compensating motions occurring between the 2-dimensional ultrasound images;
- a 3-dimensional ultrasound image forming unit for selecting a predetermined number of consecutive 2-dimensional ultrasound images from the motion-compensated 2-dimensional ultrasound images, the 3-dimensional ultrasound image forming unit further being configured to superpose the selected 2-dimensional ultrasound images to thereby form a 3-dimensional ultrasound image;
- a cutting plane selecting unit for setting at least one line on the 3-dimensional ultrasound image and cutting the 3-dimensional ultrasound image along the line to obtain a plurality of cutting planes, wherein the cutting plane selecting unit selects one cutting plane from the cutting planes; and
- a displaying unit for displaying the 3-dimensional ultrasound image and the cutting plane.
- 7.** The apparatus of Claim 6, wherein the line is a straight line.
- 8.** The apparatus of Claim 6, wherein the cutting plane selecting unit cuts the 3-dimensional ultrasound image along a depth direction.
- 9.** The apparatus of Claim 6, wherein the rendering is carried out by using an anti-aliasing method.
- 10.** The apparatus of Claim 6, wherein the motion compensation is carried out by using one of a block matching motion estimating method, a pel recursive (PR) motion estimating method and an optical flow motion estimating method.

FIG. 1

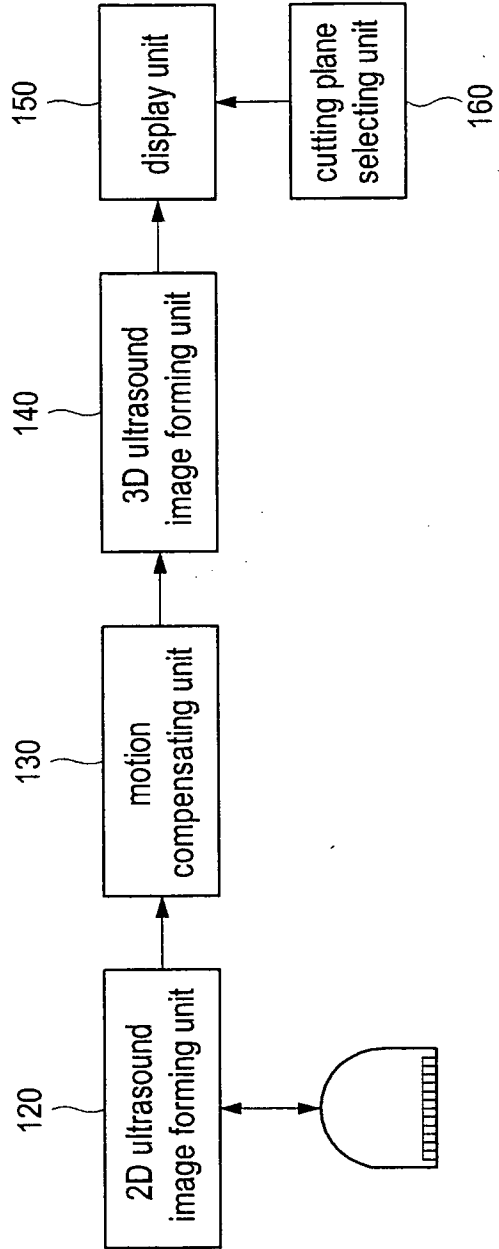

FIG. 2

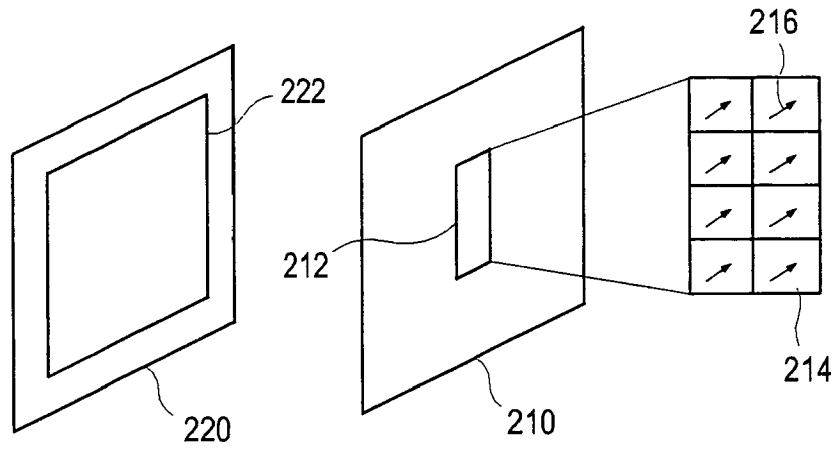

FIG. 3

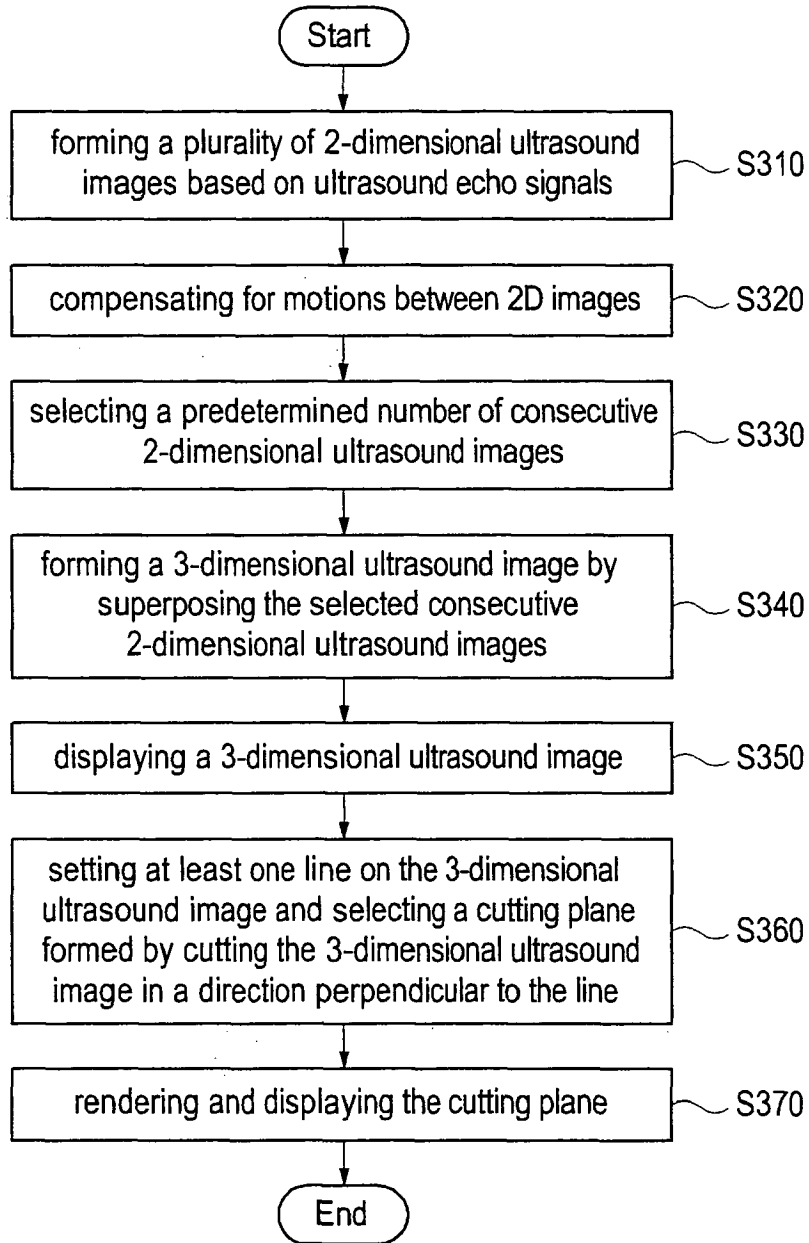

FIG. 4

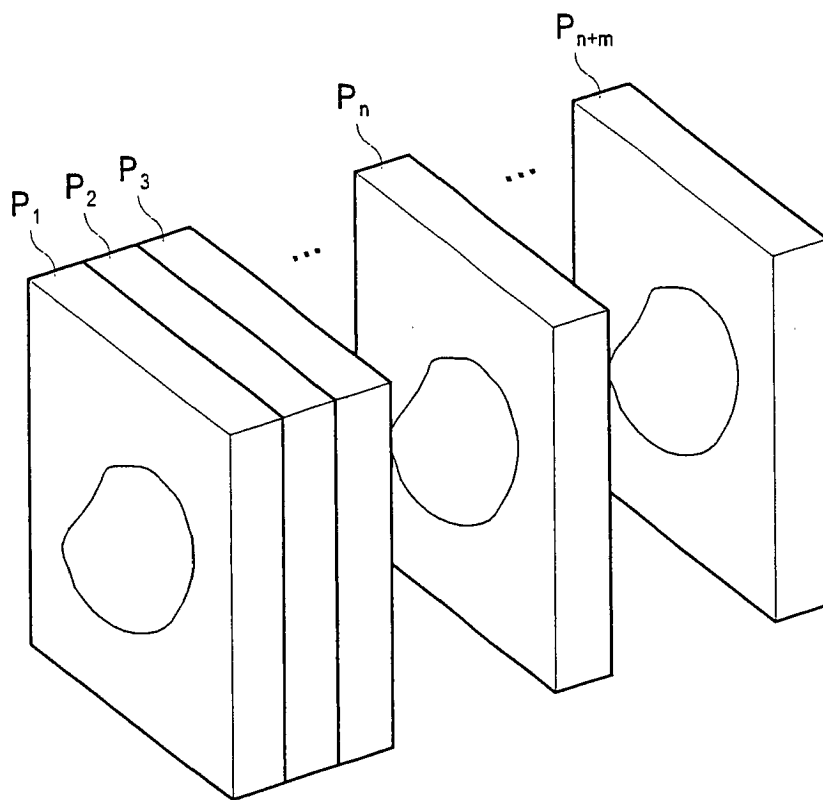

FIG. 5

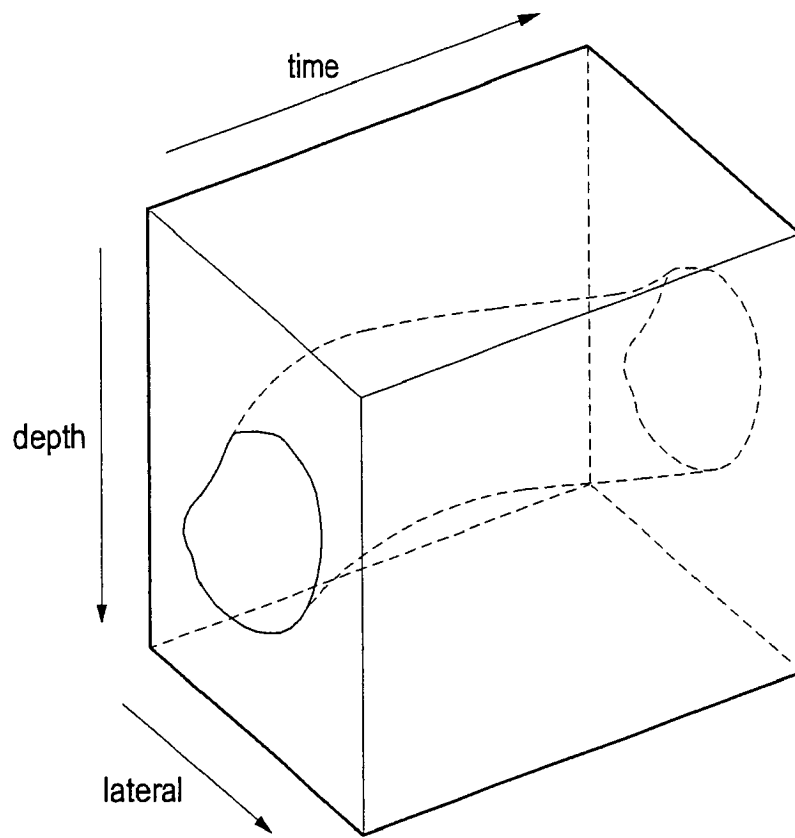

FIG. 6

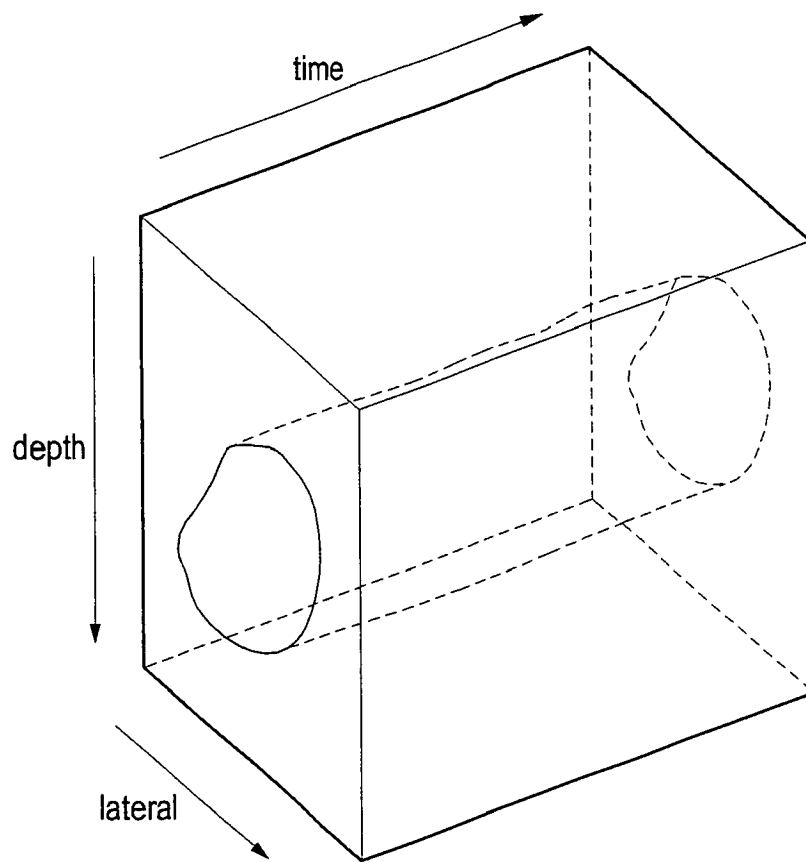
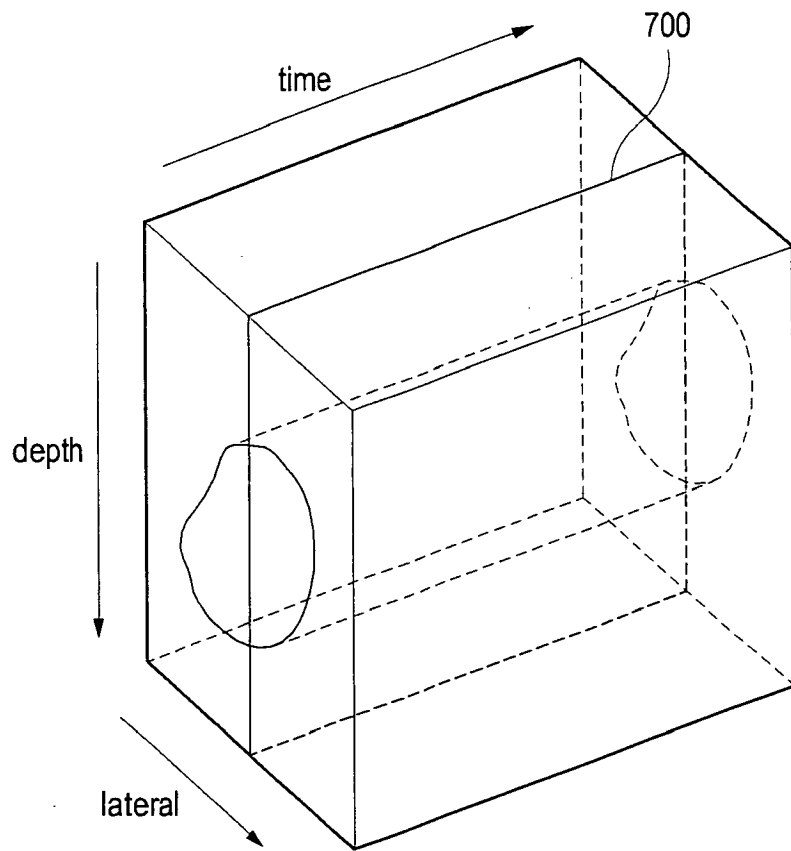

FIG. 7



REFERENCES CITED IN THE DESCRIPTION

This list of references cited by the applicant is for the reader's convenience only. It does not form part of the European patent document. Even though great care has been taken in compiling the references, errors or omissions cannot be excluded and the EPO disclaims all liability in this regard.

Patent documents cited in the description

- KR 1020060057585 [0001]

专利名称(译)	用于显示超声图像的设备和方法		
公开(公告)号	EP1873719A2	公开(公告)日	2008-01-02
申请号	EP2007008042	申请日	2007-04-20
申请(专利权)人(译)	MEDISON CO. , LTD.		
当前申请(专利权)人(译)	MEDISON CO. , LTD.		
[标]发明人	SHIN SEONG CHUL		
发明人	SHIN, SEONG CHUL		
IPC分类号	G06T7/20 G06T15/00 A61B8/00 G06T15/08		
CPC分类号	G06T19/00 A61B8/08 A61B8/0883 A61B8/483 G06T7/20 G06T2219/008		
代理机构(译)	LORENZ , WERNER		
优先权	1020060057585 2006-06-26 KR		
其他公开文献	EP1873719A3		
外部链接	Espacenet		

摘要(译)

本发明的实施例可以提供一种在超声诊断系统中显示基于二维超声图像形成的三维超声图像的装置和方法。在超声诊断系统中显示超声图像的方法包括：a) 基于从目标对象的预定区域反射的超声回波信号形成多个连续的2维超声图像；b) 补偿在二维超声图像之间发生的运动；c) 从运动补偿的二维超声图像中选择预定数量的连续二维超声图像；d) 叠加所选择的二维超声图像以形成三维超声图像；e) 在三维超声图像上设置至少一条线并沿着线切割三维超声图像以获得多个切割平面；f) 从切割平面中选择一个切割平面；g) 渲染选定的切割平面并显示渲染的切割平面。

FIG. 1

