



(51) International Patent Classification:

A61B 1/00 (2006.01) A61B 8/08 (2006.01)  
A61B 1/008 (2006.01) A61B 8/12 (2006.01)  
A61B 1/313 (2006.01) A61B 8/00 (2006.01)

(21) International Application Number:

PCT/IB2014/061083

(22) International Filing Date:

29 April 2014 (29.04.2014)

(25) Filing Language:

English

(26) Publication Language:

English

(71) Applicant: B-K MEDICAL APS [DK/DK]; Mileparken 34, DK-2730 Herlev (DK).

(72) Inventors: HANSEN, Bo; Norager Plads 19, DK-2720 Vanlose (DK). SASADY, Niels-Christian; Solbjerghave 28-105, DK-2000 Frederiksberg (DK). NYGAARD, Per Ehrenreich; Nordahl Griegs vej 90, DK-2860 Soeborg (DK).

(81) Designated States (unless otherwise indicated, for every kind of national protection available): AE, AG, AL, AM, AO, AT, AU, AZ, BA, BB, BG, BH, BN, BR, BW, BY, BZ, CA, CH, CL, CN, CO, CR, CU, CZ, DE, DK, DM, DO, DZ, EC, EE, EG, ES, FI, GB, GD, GE, GH, GM, GT, HN, HR, HU, ID, IL, IN, IR, IS, JP, KE, KG, KN, KP, KR,

KZ, LA, LC, LK, LR, LS, LT, LU, LY, MA, MD, ME, MG, MK, MN, MW, MX, MY, MZ, NA, NG, NI, NO, NZ, OM, PA, PE, PG, PH, PL, PT, QA, RO, RS, RU, RW, SA, SC, SD, SE, SG, SK, SL, SM, ST, SV, SY, TH, TJ, TM, TN, TR, TT, TZ, UA, UG, US, UZ, VC, VN, ZA, ZM, ZW.

(84) Designated States (unless otherwise indicated, for every kind of regional protection available): ARIPO (BW, GH, GM, KE, LR, LS, MW, MZ, NA, RW, SD, SL, SZ, TZ, UG, ZM, ZW), Eurasian (AM, AZ, BY, KG, KZ, RU, TJ, TM), European (AL, AT, BE, BG, CH, CY, CZ, DE, DK, EE, ES, FI, FR, GB, GR, HR, HU, IE, IS, IT, LT, LU, LV, MC, MK, MT, NL, NO, PL, PT, RO, RS, SE, SI, SK, SM, TR), OAPI (BF, BJ, CF, CG, CI, CM, GA, GN, GQ, GW, KM, ML, MR, NE, SN, TD, TG).

Declarations under Rule 4.17:

- as to the identity of the inventor (Rule 4.17(i))
- as to applicant's entitlement to apply for and be granted a patent (Rule 4.17(ii))
- of inventorship (Rule 4.17(iv))

Published:

- with international search report (Art. 21(3))



WO 2015/166302 A1

(54) Title: ULTRASOUND IMAGING PROBE

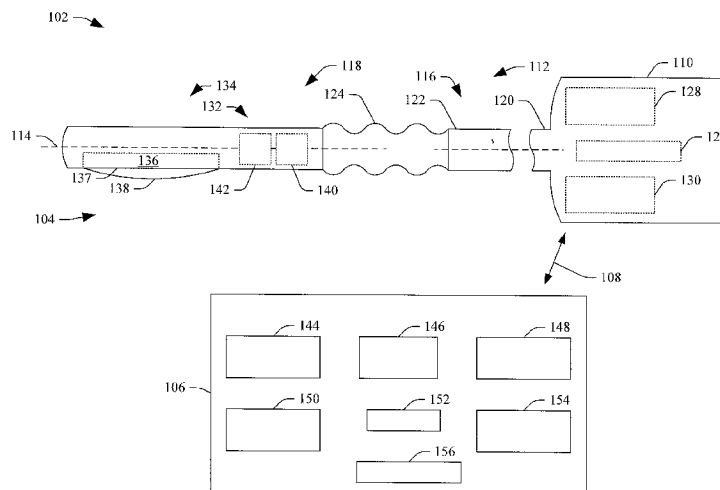

FIGURE 1

(57) Abstract: An ultrasound probe (104) includes a probe head (134). The probe head includes a transducer array (136) with a transducing surface (137), an instrument guide (142), and a light source (140). A method includes emitting a light beam, from a light source disposed on and adjacent to a transducer array of an ultrasound imaging probe, in a direction opposite of a transducing surface of the transducer array, at an inside wall of a cavity of a subject or object. A laparoscopic ultrasound imaging probe includes a shaft, a body, an articulating member that couples the probe head, and a handle coupled to the elongate shaft. The articulating probe head includes a transducer array that generates an ultrasound signal that traverses an image plane of the transducer array, an instrument guide, and a light source arranged to emit light in a direction opposite of the image plane.

## ULTRASOUND IMAGING PROBE

### TECHNICAL FIELD

The following generally relates to ultrasound and more particularly to an ultrasound probe and is described with particular application to ultrasound imaging.

### BACKGROUND

An ultrasound imaging system has included an ultrasound probe with a transducer array and a console. The ultrasound probe houses a transducer array, and the console includes a display monitor and a user interface. The transducer array transmits an ultrasound signal into a field of view and receives echoes produced in response to the signal interacting with structure therein. The echoes are processed, producing images of the scanned structure, which may be visually presented through the display monitor. An example ultrasound probe is a laparoscopic ultrasound probe. A laparoscopic ultrasound probe has been used to guide a needle to structure of interest inside of a cavity of an object or subject, e.g., in connection with a biopsy, radio frequency (RF) ablation, etc.

One approach includes using a needle that is wound around the ultrasound probe and supported adjacent to the transducer array. The transducer array and hence the needle are guided to the structure of interest through ultrasound or other images. In another approach, the needle is first attached to the transducer array outside of the cavity. Then, the other end of the needle is fed through a trocar into the cavity. Forceps are inserted into the cavity through another trocar and used to grasp the needle in the cavity and pull it up through the trocar. Concurrently, the ultrasound probe is fed into the cavity through the first trocar. The transducer array and hence the needle can then be guided to the structure.

Examples of the above two approaches are described in US 6,086,169, filed April 19, 1996, and entitled "Method and an apparatus for the insertion of a needle guide into a patient in order to remove tissue samples," which is incorporated by reference in its entirety herein. Unfortunately, the above approaches utilize a long flexible needle that can be expensive (e.g., relative to a free hand needle) and difficult to use. Furthermore, the second approach requires predicting where to insert the needle through the cavity wall to reach the structure of interest, which may require a high degree of skill, and may result in a less than optimal site for the guiding the needle to the structure of interest.

### SUMMARY

Aspects of the application address the above matters, and others.

In one aspect, an ultrasound probe includes a probe head. The probe head includes a transducer array with a transducing surface, an instrument guide, and a light source.

In another aspect, a method includes emitting a light beam, from a light source disposed on and adjacent to a transducer array of an ultrasound imaging probe, in a direction opposite of a transducing surface of the transducer array, at an inside wall of a cavity of a subject or object.

In another aspect, a laparoscopic ultrasound imaging probe includes a shaft, a body, an articulating member that couples the probe head, and a handle coupled to the elongate shaft. The articulating probe head includes a transducer array that generates an ultrasound signal that traverses an image plane of the transducer array, an instrument guide, and a light source arranged to emit light in a direction opposite of the image plane.

Those skilled in the art will recognize still other aspects of the present application upon reading and understanding the attached description.

### BRIEF DESCRIPTION OF THE DRAWINGS

The application is illustrated by way of example and not limitation in the figures of the accompanying drawings, in which like references indicate similar elements and in which:

Figure 1 schematically illustrates an example probe with a light source and an instrument guide;

Figure 2 illustrates example up/down movement of a head of the probe;

Figure 3 illustrates example right/left movement of the head of the probe;

Figure 4 schematically illustrates a side view of the head of the probe;

Figure 5 schematically illustrates a top down view of the head of the probe;

Figure 6 schematically illustrates a bottom up view of the head of the probe;

Figure 7 schematically illustrates a variation of the light source and the instrument guide;

Figure 8 schematically illustrates another variation of the light source and the instrument guide;

Figure 9 schematically illustrates another variation of the light source and the instrument guide;

Figure 10 schematically illustrates another variation of the light source and the instrument guide;

Figure 11 schematically illustrates another variation of the light source and the instrument guide;

Figure 12 schematically illustrates another variation of the light source and the instrument guide;

Figure 13 schematically illustrates another variation of the light source and the instrument guide;

Figure 14 schematically illustrates a variation of the instrument guide;

Figure 15 schematically illustrates another variation of the instrument guide;

Figure 16 schematically illustrates another variation of the instrument guide;

Figure 17 illustrate the probe in operation; and

Figure 18 illustrates an example method.

#### DETAILED DESCRIPTION

Figure 1 schematically illustrates an imaging system 102 such as ultrasound imaging system. The imaging system 102 includes an ultrasound probe 104 and a console 106. The ultrasound probe 104 and the console 106 are in electrical communication through a communications channel 108, which may be through a wireless or a hard wire (e.g., electro-mechanical connector, a cable, etc.) communications channel.

The ultrasound probe 104 includes a handle 110 and an elongate shaft 112 having a long axis 114. The elongate shaft 112 includes a body 116 and a head 118, both aligned along the long axis 114. The body 116 includes a first end 120 and a second opposing end 122. The first end 120 of the body is affixed to the handle 110. An articulating member 124 couples the second end 122 of the body and the head 118. The articulating member 124 articulates in at least four directions. In a variation, the articulating member 124 is omitted and the ultrasound probe 104 is a rigid, or non-articulating, probe.

The handle 110 includes electronics 126, a first actuator 128 and a second actuator 130. The electronics 126 provide power and/or data channels. The first actuator 128 actuates the articulating member 124 to control up/down movement of the head 118. The

second actuator 130 actuates the articulating member 124 to control left/right movement of the head 118. Figures 2 and 3 respectively show example actuation of the actuators 128 and 130 and corresponding up/down and left/right movement of the head 118.

An example of a transducer probe with an articulating head is the transducer data type 8666, which is a product of BK-Medical ApS, a company of Herlev, Denmark, which is a wholly owned subsidiary of Analogic Corporation, a company of MA, USA. Example approaches for articulating an articulating head of a transducer probe with an articulating head are described in patent applications PCT/IB2011/001622 and PCT/IB2013/000043, which are incorporated herein by reference in their entireties.

The head 118 includes a first end region 132 and a second opposing end region 134. A transducer array 136 is disposed in the second end region 134. The transducer array 136 includes a one-dimensional (1D) or two-dimensional (2D) array of transducer elements. Suitable arrays include linear, curved (e.g., convex), phased, etc. The transducer array 136 can be fully populated or sparses. The transducer array 136 includes a transducing surface 137. An ultrasonic window 138 is disposed adjacent to a transducing side of transducer array 136.

A light source 140 and an instrument guide 142 are disposed in the first end region 132. As described in greater detail below, the light source 140 is arranged with respect to the instrument guide 142 to illuminate, when inside a cavity, a region on an inside wall of cavity, which aligns with a path traversing the slot of the instrument guide 142. As such, a clinician, e.g., guided by a laparoscopic camera, can identify an instrument insertion point on an outside wall of the cavity. For example, the clinician can press around on the outside of the cavity until the depression on the inside wall of the cavity aligns with the illuminated region. This assures the clinician that the insertion point will allow a free hand instrument to reach the instrument guide 142, e.g., under ultrasound image guidance, for guidance of the instrument to a structure of interest inside of the cavity.

The probe 104 can be used for laparoscopic, endoscopic, and/or other ultrasound applications, and can be used to assist personnel, for example, with an interventional procedure such as a liver, gall bladder, tumor biopsy, etc., guide personnel, for example, with biopsy, RF ablation, chemical injection, etc. As shown, the probe 104 is employed with the console 106. In other embodiments, the probe 104 can be employed with other consoles and/or devices, via cable or wireless communication.

The console 106 includes a transmit circuit 144 and a receive circuit 146. The transmit circuit 144 controls the phasing and/or time of actuation of the individual elements of the transducer array 136, which allows for steering and/or focusing the transmitted beam. The receive circuit 146 receives signals indicative of the echoes received by the transducer array 136 and can beamform (e.g., delay and sum) the received echoes.

The console 106 further includes an echo processor 148 that processes received echoes. Such processing may include beamforming (e.g., delay and sum) the echoes. For example, with B-mode, the echo processor 148 can produce a sequence of focused, coherent echo samples along focused scanlines of a scanplane. Other processing may lower speckle, improve specular reflector delineation, and/or includes FIR filtering, IIR filtering, etc.

The console 106 further includes a scan converter 150 that scan converts (using analog and/or digital scan converting techniques) the frames of data to generate data for display, for example, by converting the data to the coordinate system of the display. This may include changing the vertical and/or horizontal scan frequency of signal based on the display. The console 106 further includes a display 152 that visually presents the scan converted data.

The console 106 further includes a user interface (UI) 154 with one or more input devices (e.g., a button, a knob, a touchscreen, etc.) and/or one or more output devices (e.g., a display monitor, an audio presenter, etc.), which allows for interaction with the system 102. The console 106 further includes a controller 156 that controls at least one of the transmit circuit 144, the receive circuit 146, the echo processor 148, the scan converter 150, the display 152 or the user interface 154.

At least one of the components of the console 106 can be implemented by way of computer readable instructions, encoded or embedded on computer readable storage medium (which excludes transitory medium) including physical memory and/or other non-transitory medium, which, when executed by a computer processor(s), causes the processor(s) to carry out functions. At least one of the instructions, optionally, is carried by a signal, carrier wave or other transitory medium.

Figures 4, 5 and 6 illustrate a non-limiting example of the light source 140 and the instrument guide 142. Figure 4 shows a side view, Figure 5 shows a top down view into a top 500, and Figure 6 shows a bottom up view from a bottom 600.

The instrument guide 142 includes a material free region or slot 402. The slot 402 is configured to allow an instrument to pass through the instrument guide 142. For example, where the instrument is a needle, the slot 402 may have a diameter that allows a needle having a gauge in a range from 14 to 20 G (or other over or non-overlapping range) to pass. For this, the diameter may be on the order of the largest needle gauge (1.600 mm for 14 G) plus a margin (e.g., 0.050 mm or higher).

The slot 402 is angled (with respect to the long axis of the shaft 112) and extends in a direction from the transducer array 136 towards the articulating region 124. This allows a portion of an instrument advancing from the side of the handle 100 to enter the slot 402, traverse there through, and enter a field of view 404 of the transducer array 136. As an example, Figure 4 shows an imaginary path 406 extending through the slot 402 and into the field of view 404. The angle of the illustrated slot 402 is not limiting.

The light source 140, similar to the slot 402, is angled with respect to the long axis of the shaft 112. In the illustrated embodiment, the angle of each of the light source 140 and the slot 402, with respect to the long axis of the shaft 112, is the same. The light source 140 is also off-set, along the long axis, from the slot 402. As such, the light emitted therefrom traverses a path 410, which is parallel to the path 406, in a direction from the transducer array 136 in a direction of the articulating region 124.

A window 412 provides a path for the light source 140 to exit the shaft 112. The window 412 can include a lens, a prism, a filter, and/or other optical element. With the above described configuration, a central location of the light emitted from the light source 140 will illuminate a region on the inside wall of the cavity that is off-set from the insertion point of the instrument in the cavity wall. As discussed herein, this allows the clinician to locate the insertion point for the instrument from inside the cavity.

The light source 140 can include one or more light emitting elements such as one or more of a laser, a light emitting diode (LED), an optic fiber, or the like. The light source 14 emits a light beam that generates a light spot (e.g., on an incident surface) having a diameter in a range of one (1) millimeter to fifty (50) millimeters. For example,

in one instance, the light source 140 emits a light beam that generates a light spot with a diameter in a range of two (2) millimeters to four (4) millimeters.

Power for the light source 140 can be from an internal battery (re-chargeable or disposable), capacitor, etc. located in the shaft 112, the handle 110 and/or otherwise in connection with the ultrasound probe 104, and/or from an external power supply, for example, from the console 106 and/or otherwise. Figure 4 shows an example in which power is supplied to the light source 140 through an internal electrical path 414.

Variations are described next.

Figure 7 illustrates a variation in which the light source 140 and the instrument guide 142 are at different angles. With this embodiment, the central location of the light emitted from the light source 140 will illuminate a region on the inside wall of the cavity that is closer to the insertion point and, in some instances, depending on a distance from the light source 140 and the instrument guide 142, may align with the insertion point.

Figure 8 illustrates a variation in which the location of the light source 140 and the instrument guide 142 along the long axis 114, with respect to transducer array 136, is reversed, and the light source 140 is on the transducer array 136 side and the instrument guide 142 is on the articulating member 124 side. In Figures 4-6, the light source 140 is on the articulating member 124 side and the instrument guide 142 is on the transducer array 136 side.

Figure 9 illustrates a variation in which the light source 140 emits light in a direction of the long axis 114 and an element 702 reflects the light down a light pipe 704 and out of a window 706. The element 702 may include a mirror and/or reflective surface and/or coating. Figure 10 illustrates a variation in which the light source 140 is flush 1002 with a surface of the shaft 112.

Figure 11 illustrates a variation in which the light source 140 surrounds an outer perimeter of the instrument guide 142. In this variation, a central region of the light pattern on the inside wall of the cavity identifies the insertion point. Figure 12 illustrates a variation in which the light source 140 protrudes from a surface 1202 of the shaft 112. In this variation, the window 412 is omitted.

Figure 11 illustrates a variation in which the light source 140 surrounds an outer perimeter of the instrument guide 142. In this variation, a central region of the light pattern on the inside wall of the cavity identifies the insertion point. Figure 12 illustrates a

variation in which the light source 140 protrudes from a surface 1202 of the shaft 112. In this variation, the window 412 is omitted.

Figure 13 illustrates a variation in which the light source 140 and the instrument guide 142 are not angled with respect to the head 118. In Figure 13, the head 118 is shown in an articulated position.

Figures 14, 15 and 16 illustrate non-limiting examples of the instrument guide 142. In Figure 14, the slot 402 of the instrument guide 142 is cylindrical in shape. In Figure 15, the slot 402 of the instrument guide 142 includes a "C" shape cut out 1502. In Figure 16, the slot 402 of the instrument guide 142 includes a "V" shaped cut out 1602. Other variations are also contemplated herein. In general, the slot 402 is configured to allow an instrument of interest to pass there through.

Figure 17 shows the probe 104 in use. In Figure 17, a laparoscopic camera 1700 is inserted into an abdominal cavity 1702 of a patient 1704. The abdominal cavity 1702 is held in a distended state through a gas supplied by an insufflator or the like. The laparoscopic camera 1700 is inserted into the abdomen cavity 1702 through a first trocar 1706. The laparoscopic camera 1700 is operated so that an inside wall 1708 of the abdominal cavity 1702 is in its field of view 1710.

The head 118 of shaft 112 is also inserted into the abdominal cavity 1702 of the patient 1704. The head 118 is inserted into the abdomen cavity 1702 through a second trocar 1712. The head 118 is positioned so that a structure of interest 1714 is in the field of view 404. In this position, the light source 140 emits the light 410 which illuminates a region 1716 on the inside wall 1708 of the abdominal cavity 1702. The laparoscopic camera 1700 generates an image or video which shows the illuminated region 1716.

From the illuminated region 1716, an insertion point 1718 is located on an outside wall 1720 of the abdominal cavity 1702 by pressing on the outside wall 1720 and identifying the point at which the depression inside the wall coincides with the illuminated region 1716. A needle instrument 1722 is inserted at the insertion point 1718 and is advanced along the path 404 to the slot 402 in the instrument guide 142. The needle instrument 1722 is guided along the path 404 to the slot 402 using ultrasound and/or other image data and advanced to the structure of interest 1714 using the instrument guide 142 and the ultrasound and/or other image data.

Figure 18 illustrates a method for employing the probe 104.

It is to be appreciated that the order of the following acts is provided for explanatory purposes and is not limiting. As such, one or more of the following acts may occur in a different order. Furthermore, one or more of the following acts may be omitted and/or one or more additional acts may be added.

At 1802, the head 118 of the probe 204 is inserted into a cavity of a subject or object.

At 1804, the transducer array 126 of the probe 204 is excited to acquire image data of structure in the cavity.

At 1806, the image data is visually observed to locate a structure of interest in the cavity.

At 1808, the light source 140 of the probe 104 is activated, illuminating a region on the inside wall of the cavity.

At 1810, an operator presses on an outside surface of the cavity.

At 1812, a camera in the cavity acquires data showing the illuminated region and depressions from the pressing.

At 1814, an instrument insertion point is identified in response to a depression coinciding with the illuminated region.

At 1816, an instrument is inserted at the insertion point.

At 1818, the instrument is guided to the slot 402 of the instrument guide 142, under image data and/or other guidance.

At 1820, the instrument is advanced in the instrument guide 142 to the structure of interest, under guidance of the instrument guide and image data and/or other guidance.

At 1822, a procedure is performed on the structure of interest with the instrument.

The application has been described with reference to various embodiments. Modifications and alterations will occur to others upon reading the application. It is intended that the invention be construed as including all such modifications and alterations, including insofar as they come within the scope of the appended claims and the equivalents thereof.

## CLAIMS

What is claimed is:

1. An ultrasound probe (104), comprising:  
a probe head (118), including:  
a transducer array (136) with a transducing surface (137);  
an instrument guide (142); and  
a light source (140).
2. The ultrasound probe of claim 1, further comprising:  
an elongate shaft (112) having a long axis (114), the elongate shaft, including:  
the probe head; and  
a body (116) with first and second ends (120,122), wherein one of the first or second end is coupled to the probe head; and  
a handle (110) coupled to the other of the first or second end.
3. The ultrasound probe of claim 2, the elongate shaft, further comprising:  
an articulating member (124) that couples the probe head and the one of the first or second end.
4. The ultrasound probe of any of claims 1 to 3, wherein the transducer array, the instrument guide and the light source are disposed along the long axis.
5. The ultrasound probe of claim 4, wherein the instrument guide and the light source are adjacent to each other along the long axis.
6. The ultrasound probe of claim 4, wherein the light source surrounds the instrument guide.
7. The ultrasound probe of any of claims 1 to 6, wherein a light emission path of the light source is in a direction opposite to the transducing surface.

8. The ultrasound probe of any of claims 1 to 7, wherein the light source is disposed at an angle with respect to the transducer array.
9. The ultrasound probe of any of claims 7 to 8, the ultrasound probe, comprising:  
a top (500) and a bottom (600), and the instrument guide, comprising:  
a slot (402) that extends through the ultrasound probe from the top to the bottom.
10. The ultrasound probe of claim 9, wherein the slot defines an instrument path through the instrument guide.
11. The ultrasound probe of any of claims 9 to 10, wherein the slot has a diameter in a range of 0.413 millimeters to 3.00 millimeters.
12. The ultrasound probe of any of claims 10 to 11, wherein the instrument path and the light emission path are parallel to each other.
13. The ultrasound probe of any of claims 1 to 12, wherein the light source includes one or more of a laser, a light emitting diode, or an optical fiber.
14. The ultrasound probe of any of claims 1 to 13, wherein the light source emits a light spot having a diameter in a range of one (1) millimeter to fifty (50) millimeters.
15. A method, comprising:  
emitting a light beam, from a light source disposed on and adjacent to a transducer array of an ultrasound imaging probe, in a direction opposite of a transducing surface of the transducer array, at an inside wall of a cavity of a subject or object.
16. The method of claim 15, further comprising:  
identifying an insertion point for an instrument on an outside wall of the cavity based a region of the inside wall illuminated by the light.

17. The method of claim 16, further comprising:  
identifying the insertion point as a point next to the illuminated region.
18. The method of claim 16, further comprising:  
identifying the insertion point as a central region of the illuminated region.
19. The method of any of claims 15 to 18, further comprising:  
emitting the light beam in a direction parallel to an instrument path through an instrument guide of the ultrasound imaging probe.
20. A laparoscopic ultrasound imaging probe, comprising:  
a shaft, including:  
    an articulating probe head, including:  
        a transducer array that generates an ultrasound signal that traverses  
        an image plane of the transducer array;  
        an instrument guide; and  
        a light source arranged to emit light in a direction opposite of the  
        image plane;  
a body;  
an articulating member that couples the probe head and the body and articulates the  
articulating probe head; and  
a handle coupled to the elongate shaft.

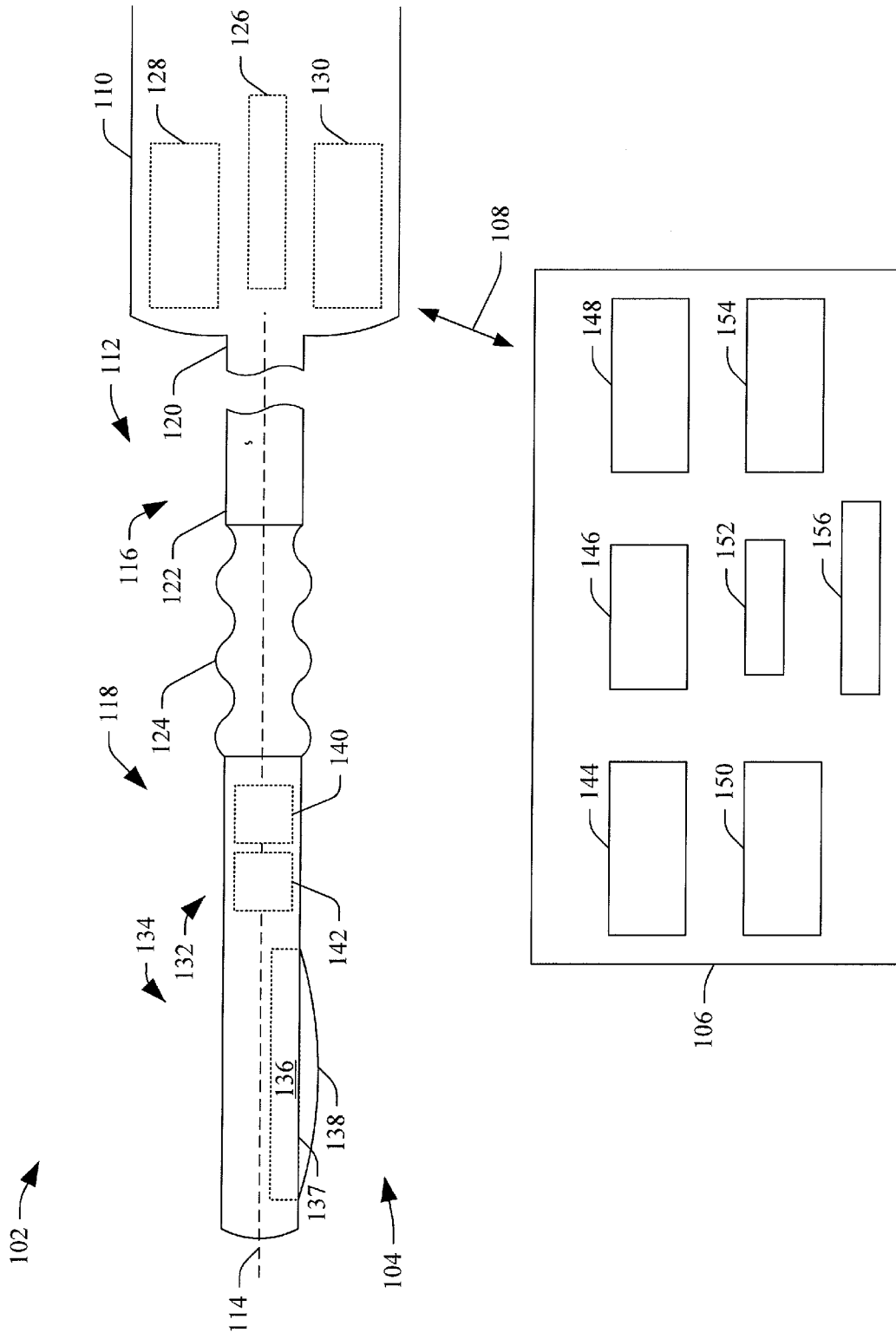

FIGURE 1

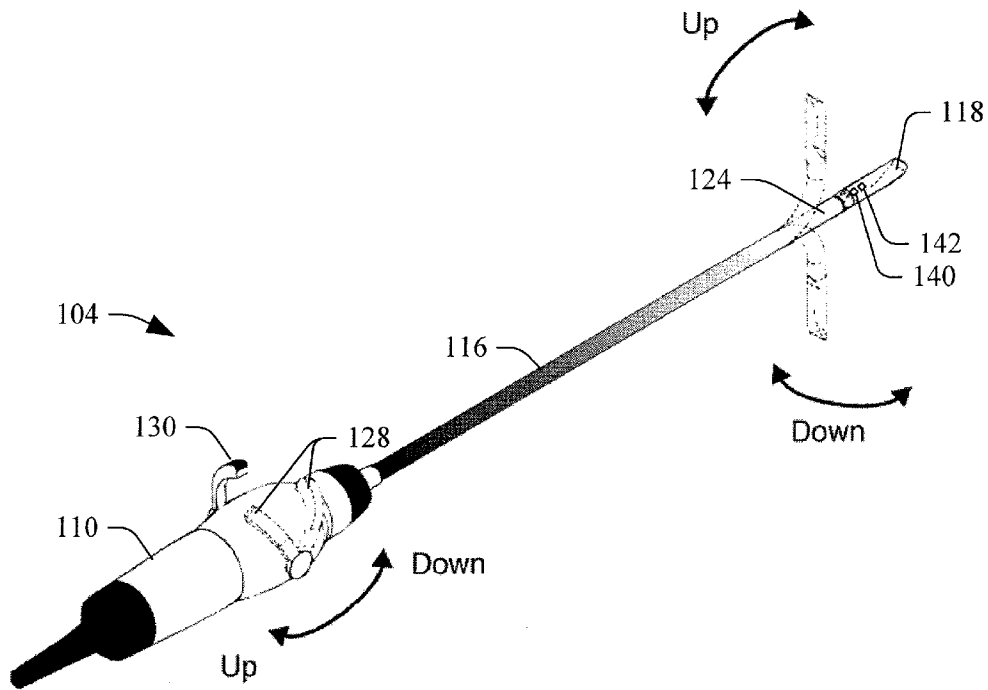

FIGURE 2

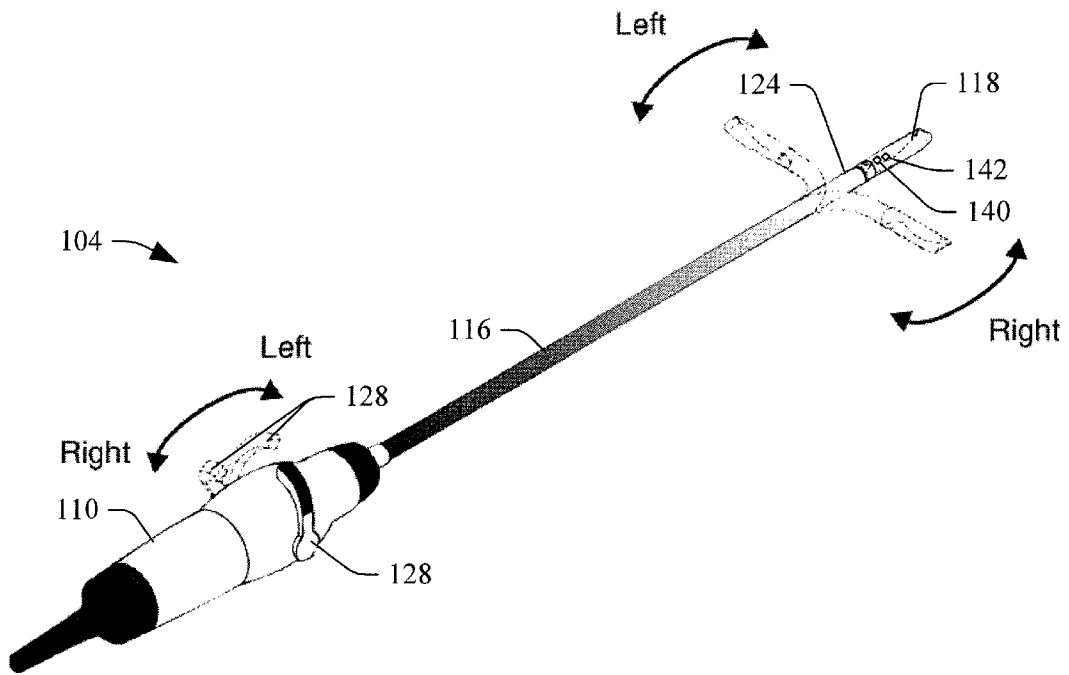

FIGURE 3

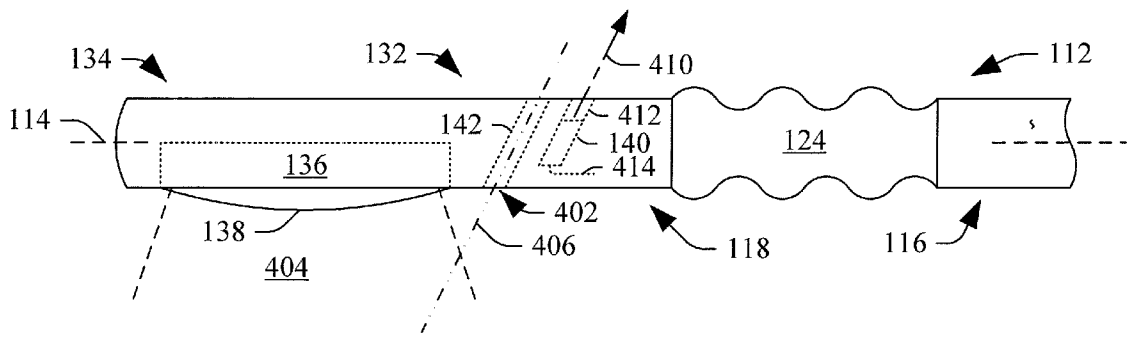

FIGURE 4

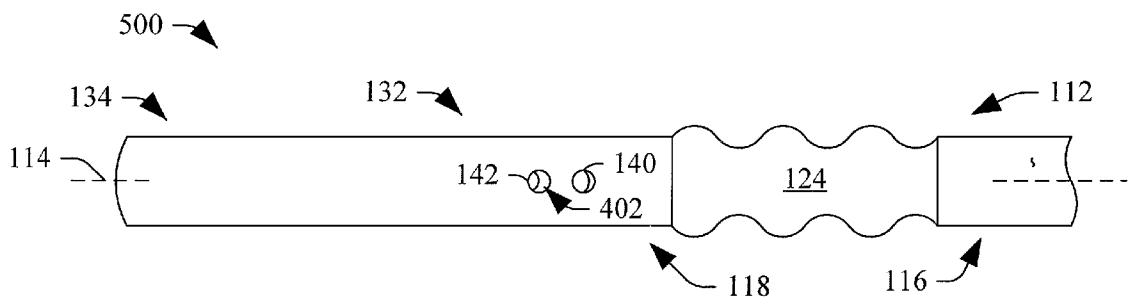

FIGURE 5

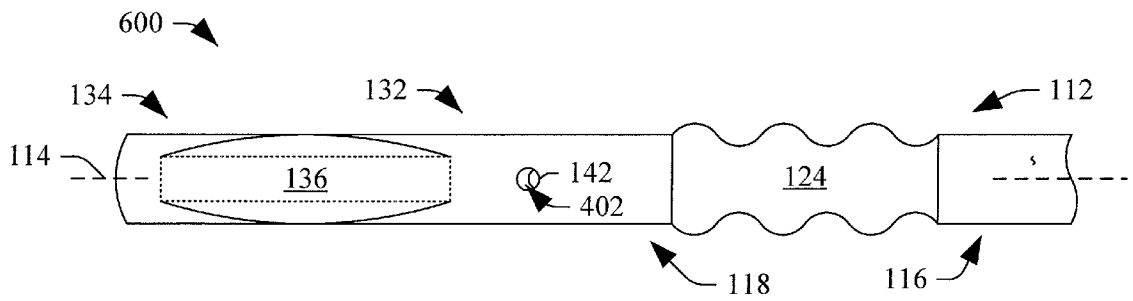

FIGURE 6

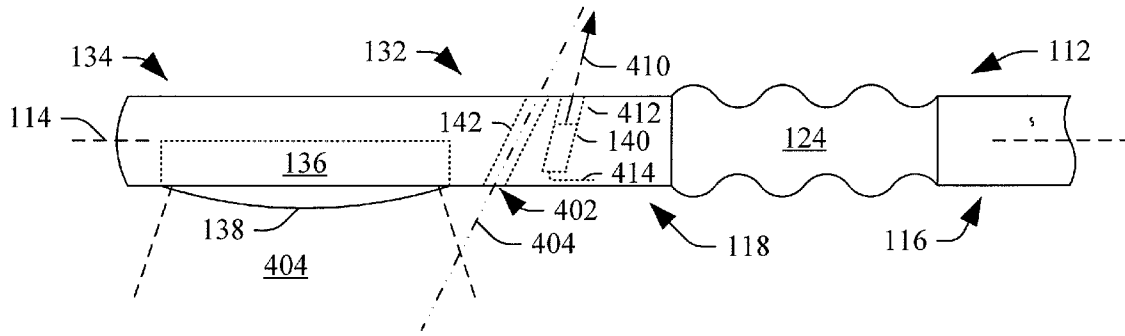

FIGURE 7

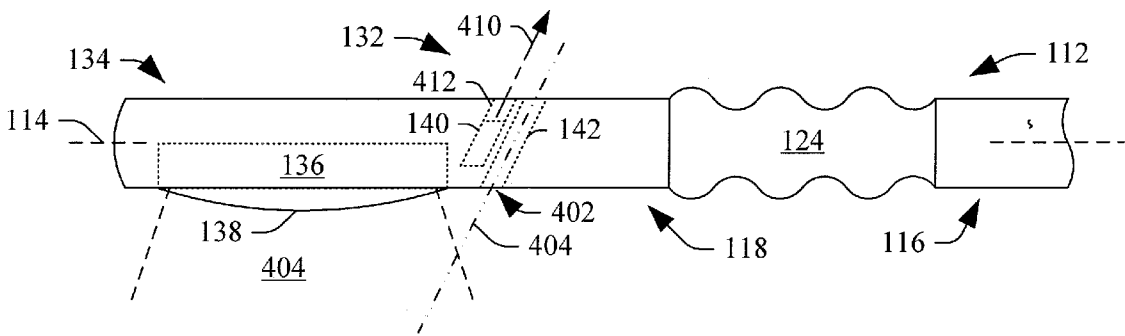

FIGURE 8

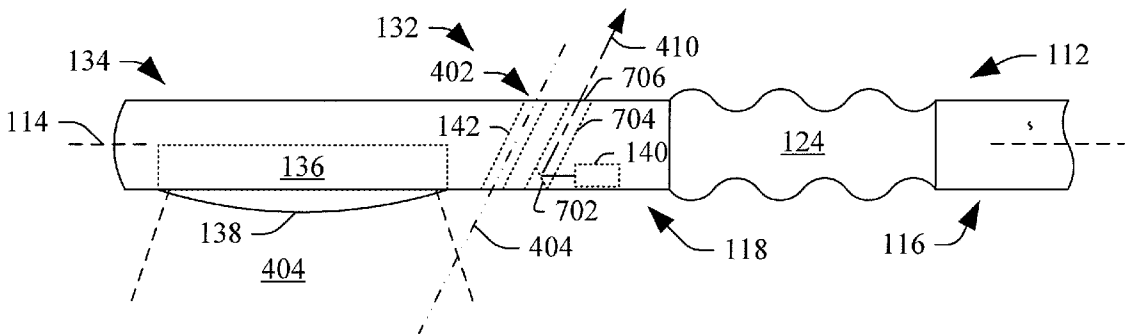

FIGURE 9

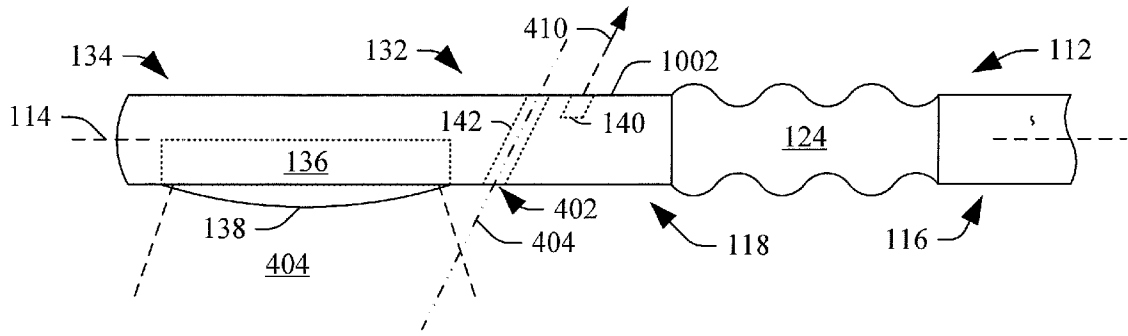

FIGURE 10

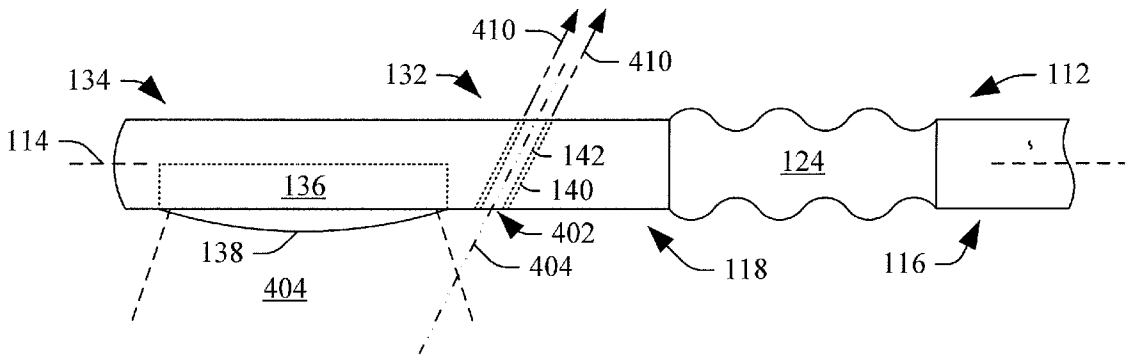

FIGURE 11

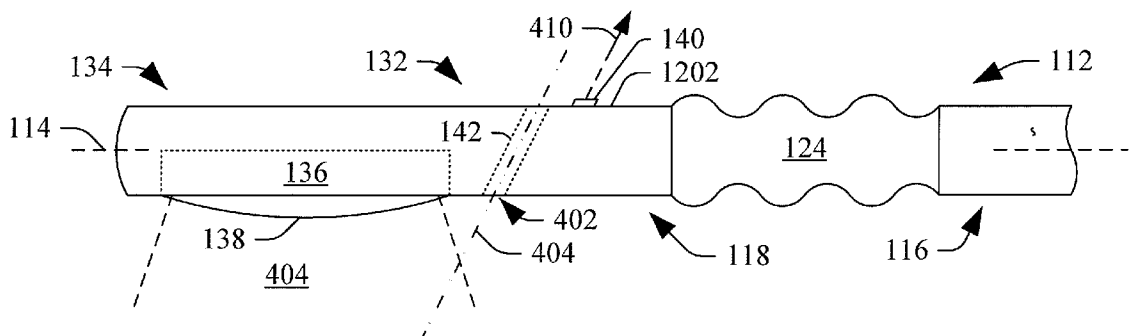

FIGURE 12

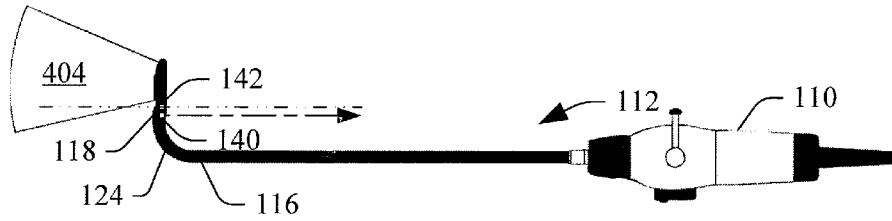

FIGURE 13

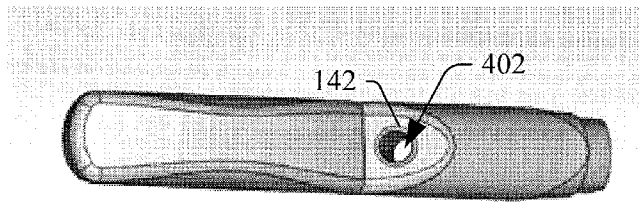

FIGURE 14

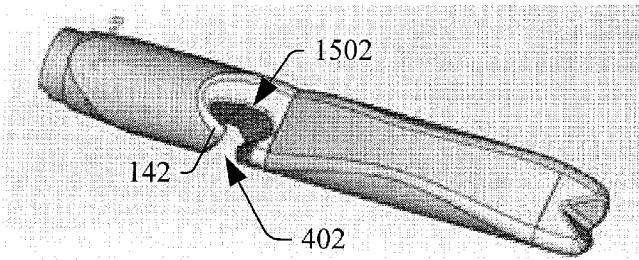

FIGURE 15

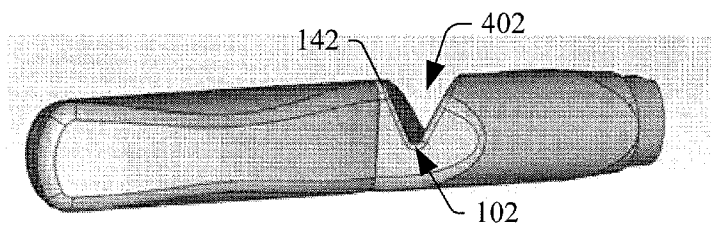

FIGURE 16

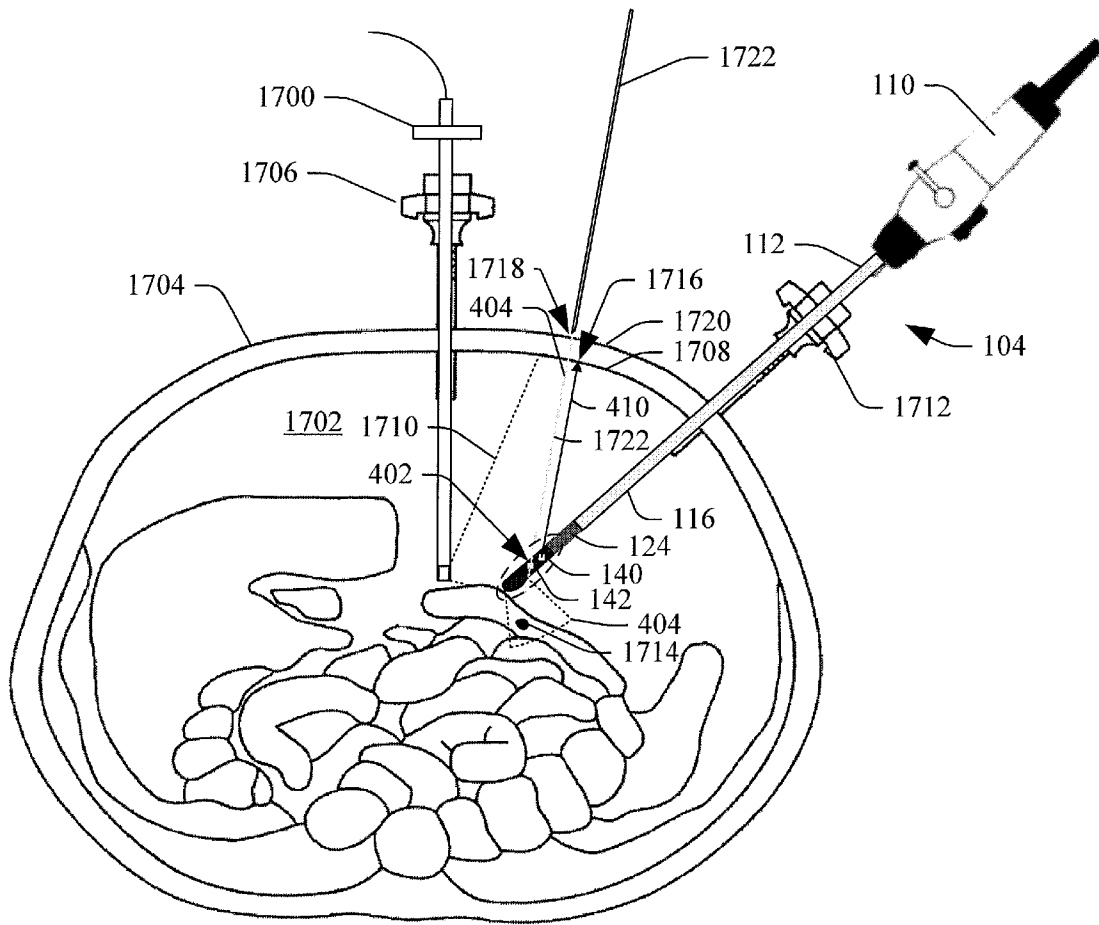

FIGURE 17

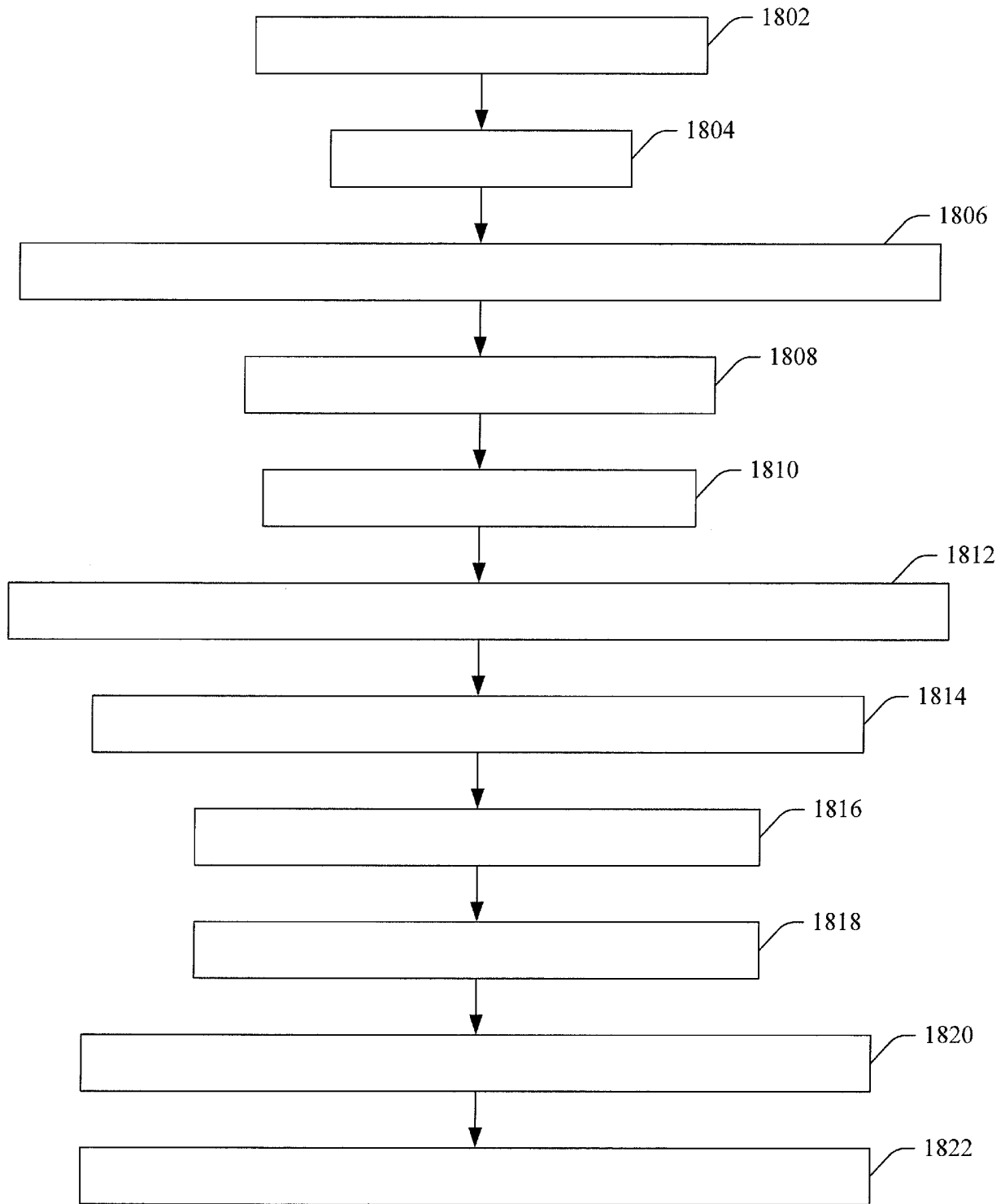

FIGURE 18

**INTERNATIONAL SEARCH REPORT**

International application No PCT/IB2014/061083
---

**A. CLASSIFICATION OF SUBJECT MATTER**  
 INV. A61B1/00 A61B1/008 A61B1/313 A61B8/08 A61B8/12  
 A61B8/00  
 ADD.  
 According to International Patent Classification (IPC) or to both national classification and IPC

**B. FIELDS SEARCHED**  
 Minimum documentation searched (classification system followed by classification symbols)  
 A61B

Documentation searched other than minimum documentation to the extent that such documents are included in the fields searched

Electronic data base consulted during the international search (name of data base and, where practicable, search terms used)  
 EPO-Internal

**C. DOCUMENTS CONSIDERED TO BE RELEVANT**

Category*	Citation of document, with indication, where appropriate, of the relevant passages	Relevant to claim No.
X	EP 2 138 092 A1 (OLYMPUS MEDICAL SYSTEMS CORP [JP]) 30 December 2009 (2009-12-30) abstract paragraph [0016] - paragraph [0036] figures 1-4	1-6,8, 13,14
X	----- US 4 763 662 A (YOKOI TAKESHI [JP]) 16 August 1988 (1988-08-16) the whole document	1-14,20
X	----- EP 0 668 052 A2 (OLYMPUS OPTICAL CO [JP]) 23 August 1995 (1995-08-23) abstract column 5, line 25 - column 16, line 58 figures 1-12 ----- -/--	1-5,8-14

Further documents are listed in the continuation of Box C.       See patent family annex.

\* Special categories of cited documents :

"A" document defining the general state of the art which is not considered to be of particular relevance	"T" later document published after the international filing date or priority date and not in conflict with the application but cited to understand the principle or theory underlying the invention
"E" earlier application or patent but published on or after the international filing date	"X" document of particular relevance; the claimed invention cannot be considered novel or cannot be considered to involve an inventive step when the document is taken alone
"L" document which may throw doubts on priority claim(s) or which is cited to establish the publication date of another citation or other special reason (as specified)	"Y" document of particular relevance; the claimed invention cannot be considered to involve an inventive step when the document is combined with one or more other such documents, such combination being obvious to a person skilled in the art
"O" document referring to an oral disclosure, use, exhibition or other means	"&" document member of the same patent family
"P" document published prior to the international filing date but later than the priority date claimed	

Date of the actual completion of the international search  15 January 2015	Date of mailing of the international search report  23/01/2015
--	--

Name and mailing address of the ISA/ European Patent Office, P.B. 5818 Patentlaan 2 NL - 2280 HV Rijswijk Tel. (+31-70) 340-2040, Fax: (+31-70) 340-3016	Authorized officer  Artikis, T
--	--------------------------------------

## INTERNATIONAL SEARCH REPORT

International application No.  
PCT/IB2014/061083

### Box No. II Observations where certain claims were found unsearchable (Continuation of item 2 of first sheet)

This international search report has not been established in respect of certain claims under Article 17(2)(a) for the following reasons:

1.  Claims Nos.: 15-19  
because they relate to subject matter not required to be searched by this Authority, namely:  
Rule 39.1(iv) PCT - Method for treatment of the human or animal body by surgery, because the claimed method involves illuminating a cavity of a subject from the inside in order to identify an external insertion point for an instrument.
2.  Claims Nos.:  
because they relate to parts of the international application that do not comply with the prescribed requirements to such an extent that no meaningful international search can be carried out, specifically:
3.  Claims Nos.:  
because they are dependent claims and are not drafted in accordance with the second and third sentences of Rule 6.4(a).

### Box No. III Observations where unity of invention is lacking (Continuation of item 3 of first sheet)

This International Searching Authority found multiple inventions in this international application, as follows:

1.  As all required additional search fees were timely paid by the applicant, this international search report covers all searchable claims.
2.  As all searchable claims could be searched without effort justifying an additional fees, this Authority did not invite payment of additional fees.
3.  As only some of the required additional search fees were timely paid by the applicant, this international search report covers only those claims for which fees were paid, specifically claims Nos.:
4.  No required additional search fees were timely paid by the applicant. Consequently, this international search report is restricted to the invention first mentioned in the claims; it is covered by claims Nos.:

#### Remark on Protest

- The additional search fees were accompanied by the applicant's protest and, where applicable, the payment of a protest fee.
- The additional search fees were accompanied by the applicant's protest but the applicable protest fee was not paid within the time limit specified in the invitation.
- No protest accompanied the payment of additional search fees.

**INTERNATIONAL SEARCH REPORT**

International application No PCT/IB2014/061083
---

C(Continuation). DOCUMENTS CONSIDERED TO BE RELEVANT		
Category*	Citation of document, with indication, where appropriate, of the relevant passages	Relevant to claim No.
X	US 6 409 666 B1 (ITO KEIJI [JP]) 25 June 2002 (2002-06-25) abstract column 3, line 51 - column 5, line 16 figures 1-6 -----	1-4,8
A	WO 2013/008047 A1 (BK MEDICAL APS [DK]; HANSEN BO [DK]) 17 January 2013 (2013-01-17) cited in the application the whole document -----	1-14,20
A	US 6 083 169 A (HANSEN NIELS STENGAARD [DK]) 4 July 2000 (2000-07-04) cited in the application abstract column 2, line 44 - column 4, line 41 figures 1-6,8 -----	1-14,20

# INTERNATIONAL SEARCH REPORT

Information on patent family members

International application No

PCT/IB2014/061083

Patent document cited in search report	Publication date	Publication date	Patent family member(s)	Publication date
EP 2138092	A1	30-12-2009	CN 101612050 A	30-12-2009
			EP 2138092 A1	30-12-2009
			JP 5153476 B2	27-02-2013
			JP 2010004945 A	14-01-2010
			US 2009318831 A1	24-12-2009
-----				
US 4763662	A	16-08-1988	DE 3618906 A1	11-12-1986
			US 4763662 A	16-08-1988
-----				
EP 0668052	A2	23-08-1995	DE 69529307 D1	13-02-2003
			DE 69529307 T2	16-10-2003
			EP 0668052 A2	23-08-1995
			US 5873828 A	23-02-1999
-----				
US 6409666	B1	25-06-2002	DE 10018673 A1	09-11-2000
			US 6409666 B1	25-06-2002
-----				
WO 2013008047	A1	17-01-2013	EP 2731505 A1	21-05-2014
			JP 2014520625 A	25-08-2014
			US 2014133269 A1	15-05-2014
			WO 2013008047 A1	17-01-2013
-----				
US 6083169	A	04-07-2000	AT 300241 T	15-08-2005
			AU 5396696 A	07-11-1996
			DE 69634980 D1	01-09-2005
			DE 69634980 T2	06-04-2006
			EP 0821568 A1	04-02-1998
			US 6083169 A	04-07-2000
			WO 9632889 A1	24-10-1996
-----				

专利名称(译)	超声成像探头		
公开(公告)号	<a href="#">EP3136940A1</a>	公开(公告)日	2017-03-08
申请号	EP2014730584	申请日	2014-04-29
[标]申请(专利权)人(译)	B-K医疗公司		
申请(专利权)人(译)	B-k医疗APS		
当前申请(专利权)人(译)	B-k医疗APS		
[标]发明人	HANSEN BO SASADY NIELS CHRISTIAN NYGAARD PER EHRENREICH		
发明人	HANSEN, BO SASADY, NIELS-CHRISTIAN NYGAARD, PER EHRENREICH		
IPC分类号	A61B1/00 A61B1/008 A61B1/313 A61B8/08 A61B8/12 A61B8/00		
CPC分类号	A61B1/00174 A61B1/008 A61B1/3132 A61B8/0833 A61B8/0841 A61B8/085 A61B8/12 A61B8/4466 A61B8/4483 A61B8/4488 A61B8/14 A61B8/461 A61B8/5215		
外部链接	<a href="#">Espacenet</a>		

#### 摘要(译)

超声探头 ( 104 ) 包括探头 ( 134 )。探头包括具有换能表面 ( 137 ) 的换能器阵列 ( 136 )，仪器引导件 ( 142 ) 和光源 ( 140 )。一种方法包括从设置在超声成像探头的换能器阵列上并与其相邻的光源，在与换能器阵列的换能表面相反的方向上，在对象的腔体的内壁处发射光束，或者目的。腹腔镜超声成像探头包括轴，主体，连接探头的铰接构件，以及连接到细长轴的手柄。铰接探针头包括换能器阵列，其产生穿过换能器阵列的图像平面的超声信号，仪器引导件，以及布置成在与图像平面相反的方向上发光的光源。