

(19)



(11)

EP 1 948 025 B1

(12)

EUROPEAN PATENT SPECIFICATION

(45) Date of publication and mention of the grant of the patent:
10.01.2018 Bulletin 2018/02

(51) Int Cl.:
A61B 8/08 (2006.01)

(21) Application number: **06821296.8**

(86) International application number:
PCT/IB2006/054067

(22) Date of filing: **02.11.2006**

(87) International publication number:
WO 2007/054861 (18.05.2007 Gazette 2007/20)

(54) ULTRASONIC DIAGNOSIS OF MYOCARDIAL SYNCHRONIZATION

ULTRASCHALLDIAGNOSE DER MYOKARD-SYNCHRONISIERUNG

DIAGNOSTIC DE LA SYNCHRONISATION MYOCARDIQUE PAR ULTRASONS

(84) Designated Contracting States:
AT BE BG CH CY CZ DE DK EE ES FI FR GB GR HU IE IS IT LI LT LU LV MC NL PL PT RO SE SI SK TR

- **SETTLEMIER, Scott**
Bothell, Washington 98041-3003 (US)
- **PRATER, David**
Bothell, Washington 98041-3003 (US)

(30) Priority: **08.11.2005 US 734662 P**

(74) Representative: **de Haan, Poul Erik et al**
Philips International B.V.
Philips Intellectual Property & Standards
High Tech Campus 5
5656 AE Eindhoven (NL)

(43) Date of publication of application:
30.07.2008 Bulletin 2008/31

(73) Proprietor: **Koninklijke Philips N.V.**
5656 AE Eindhoven (NL)

(56) References cited:
US-A1- 2002 072 670 US-A1- 2002 072 671
US-B1- 6 527 717 US-B1- 6 674 879

(72) Inventors:
• **SALGO, Ivan**
Bothell, Washington 98041-3003 (US)

EP 1 948 025 B1

Note: Within nine months of the publication of the mention of the grant of the European patent in the European Patent Bulletin, any person may give notice to the European Patent Office of opposition to that patent, in accordance with the Implementing Regulations. Notice of opposition shall not be deemed to have been filed until the opposition fee has been paid. (Art. 99(1) European Patent Convention).

Description

[0001] This invention relates to ultrasonic diagnostic imaging systems and, in particular, to the use of ultrasonic imaging to diagnose electrical stimulation of the heart.

[0002] Ideally the heart should pump blood with maximum efficiency. One characteristic of a healthy heart is the uniform manner in which the heart muscle is stimulated to contract, referred to as electromechanical transduction. The heart is commanded to contract by electrochemical signals passed by sodium and potassium channels in the muscle cells of the myocardium. These signals, dispersed as they are over the entire heart muscle, should command the heart muscle cells to contract at the same instant in time. When this happens the heart contracts from a relaxed, full volume to a contracted minimal volume, thereby pumping a maximal volume of blood with each heartbeat. This is a characteristic of a healthy heart. However, when the signals that stimulate this contraction cause different regions of the heart to contract at different times, the erratic contraction will pump less than the maximal volume of blood, producing reduced efficiency and taxing the heart over time. Thus it is desirable to be able to diagnose this condition so that the necessary treatment regime, generally the implantation of a pacemaker which forces synchronous contractions, can be performed if needed. This diagnosis and its treatment is referred to as cardiac resynchronization therapy, or CRT.

[0003] Several ultrasound techniques have been proposed for CRT. All of the ultrasound techniques detect the electrical stimulation of the heart indirectly, that is, by observing the motion of the heart resulting from the stimulation. In one technique the motion of the heart wall at different locations is plotted over time, referred to as segmental sub-volumetric analysis. When the heart is being stimulated synchronously the graphical plots will appear to be symmetrical. But when a region of the heart is being stimulated later than the rest or not at all, the graphical plot from that region will be different from the others and visually distinguishable. In another approach ultrasonic tissue Doppler imaging is used to depict the heart motion in color. When the colors change nonuniformly a problem with electromechanical transduction can be inferred. This information can be presented by a parametric image which depicts regions moving in one fashion in one color and regions with dissimilar motion in another color. In yet another approach Doppler is used to depict vectors over the heart which indicate local wall motion. In a healthy heart the vectors will act and change in synchronism. US 20020072671 A1 suggests computing a tissue Doppler image line along the endocardium or myocardium at locations defined by the automatically drawn border. The lines of Doppler values for all of the images are displayed in straight vertical lines. However these techniques present heart motion in abstract ways that often are not intuitive to the clinician. In part this is because both time-

motion and space need to be illustrated together. Accordingly it is desirable to provide an ultrasound technique for the diagnosis of heart motion synchronicity which is simple to use and intuitively understandable for the clinician.

[0004] In accordance with the principles of the present invention, an ultrasonic diagnostic apparatus and technique are provided for diagnosing the timing of stimulation of the heart muscle which is adaptable for cardiac resynchronization therapy. In the inventive method ultrasonic images of the heart are acquired over the heart cycle and the heart wall identified in at least one of the images. A series of lines are drawn across a chamber of the heart, referenced to points spaced along opposite sides of the heart. The reference points are tracked through the heart cycle and the lines displayed between the tracked points will move with the contraction and expansion of the heart. As the lines move over time, their positions are retained in the image and the buildup of depicted successive locations illustrate wall motion over the heart cycle. The line patterns are compared for uniformity to detect abnormal wall motion which may be due to asynchronous stimulation of the heart muscle.

[0005] In accordance with a further aspect of the present invention the tracked points are initially located on an automated heart wall tracing, then tracked from the speckle patterns of adjacent heart tissue. The points can also be tracked by following the movement of anatomical features or texture. In accordance with yet another aspect of the present invention the tracking of speckle patterns is done with respect to pre-scan converted ultrasound data.

[0006] In accordance with yet another aspect of the present invention the tracked points and lines can be drawn in various patterns and orientations such as an intersecting pattern crossing a short axis view of the heart or a generally orthogonal pattern of several sets of lines. The technique is applicable to different heart chambers including the left and right ventricles, and can be used with reference to both the endo- and epi-cardial borders.

[0007] In the drawings:

FIGURE 1 illustrates in block diagram form an ultrasonic diagnostic imaging system constructed in accordance with the principles of the present invention. FIGURE 2 is an ultrasound image of the left ventricle in which the changing locations of the mitral valve plane are depicted in gradated color shadings.

FIGURES 3 illustrates an end systole image with the endocardial border drawn automatically.

FIGURE 4 illustrates a plurality of color kinesis bands between pairs of reference points on opposite sides of the left ventricle in accordance with the principles of the present invention.

FIGURE 5 illustrates in block diagram form a portion of the ultrasound system of FIGURE 1 constructed in accordance with the principles of the present invention.

FIGURE 6 is an example of an ultrasound image produced in accordance with the present invention and depicting abnormal wall motion.

FIGURE 7 is an example of an ultrasound image produced in accordance with the present invention showing color kinesis bands across both the left and right ventricles.

FIGURE 8 is an example of an ultrasound image produced in accordance with the present invention showing color kinesis bands extending across a transverse (short axis) image of a heart chamber.

FIGURE 9 is an example of an ultrasound image produced in accordance with the present invention showing color kinesis bands along and between the endocardial wall and the epicardial wall.

FIGURE 10 is an example of an ultrasound image produced in accordance with the present invention showing lines drawn in orthogonal directions between pairs of heart chamber wall reference points.

[0008] Referring now to FIGURE 1, a first embodiment of an ultrasonic diagnostic imaging system constructed in accordance with the principles of the present invention is shown in block diagram form. A probe or scanhead 410 which includes a one dimensional (1D) or two dimensional (2D) array 412 of transducer elements transmits ultrasonic waves and received ultrasonic echo signals. This transmission and reception is performed under control of a beamformer 420 which processes received echo signals to form coherent beams of echo signals from the anatomy being scanned. The echo information is Doppler processed by a Doppler processor 430 when Doppler information is to be presented, and the processed Doppler information is coupled to an image processor 440 which forms 2D or 3D Doppler images. For B mode imaging of tissue structure the echo signals are image processed by amplitude detection and scan converted into the desired image format for display. The images pass through a Cineloop memory 460 from which they may be coupled directly to a video processor 470 for display on an image display 480. The images may also be applied to an automatic border detection (ABD) processor 490 which operates on the 2D or 3D images to define the anatomical borders and boundaries in the images as described below. The defined borders are overlaid on the images which are coupled to the video processor 470 for display. The system may operate to define and display borders on loops of images saved in the Cineloop memory 460, or to display borders drawn on real time images produced during live scanning of a patient.

[0009] The ultrasound system of FIGURE 1 can be used to produce static or live images depicting mitral annular motion as shown in FIGURE 2, which is an image taken from a constructed embodiment of the present invention. Those skilled in the art will recognize the four chamber apical grayscale ultrasound image of a heart in the center of FIGURE 2 which shows all four chambers of the heart in cross-section in this two dimensional im-

age. To the right of the ultrasound image is the standard grayscale bar 7 for the image showing the range of shading used in the image. This image is acquired by a probe 410 placed below the patient's ribs and directed upward toward the apex of the heart. The reference number 9 in FIGURE 2 marks the center of the LV with its apex 6 at the top of the ultrasound image. At the opposite side of the LV is the mitral valve. When the LV of a healthy heart contracts during the systolic phase of the heart cycle the myocardial walls of the LV all move smoothly and uniformly toward the center of the LV, including the side of the heart where the mitral valve is located. Thus, by this contractive action the mitral valve moves upward in the image toward the apex 6. During diastole the mitral valve moves back to its starting location as the heart muscle relaxes. Document WO2006024970 entitled "ULTRASONIC DIAGNOSIS OF ISCHEMIC CARDIODISEASE" describes an ultrasonic diagnostic technique in which the location of the mitral valve is tracked and depicted on the ultrasound image during the systolic phase, the diastolic phase, or both. In conventional practice physicians examine both the systolic contraction and diastolic relaxation of the heart with spectral Doppler to analyze motion of the mitral annulus, the ring of leaflet attachment in the left ventricle (LV). This analysis can be used to estimate the timing and overall motion of the LV during contraction as well as understanding the nature of constrictive and restrictive diseases of the myocardium. For example, late contraction of the LV lateral wall results in delayed excursion of the mitral annulus on that side. The diagnostic technique of the '486 application describes apparatus and a method for detecting and quantifying these motional aberrations of a diseased heart. The application describes the tracking of mitral annular motion for parametric display of mitral annular motion; use of this tracking information to map Doppler motion onto the parametric display; and to quantify both the timing and degree of excursion of mitral annular motion. In practice of the technique a sequence of images acquired during a heart cycle are analyzed to detect the mitral valve annulus as described below or by other known techniques. Preferably the position of the mitral annulus is detected rather than the valve leaflets to provide a more stable motional reference. The mitral valve location is graphically marked on an image as by a distinctive line or color stripe. This process is repeated for the next and all successive images in the sequence. Furthermore, the lines or stripes are accumulated so that each new image retains the lines or stripes identified in the previous images in the sequence and in the same locations in relation to a static reference in which they were detected. As the sequence progresses the lines or stripes build up, depicting the path of successive positions of the mitral valve during the sequence of contraction or expansion. A build-up of such color stripes is shown in FIGURE 2. In the actual color image from which FIGURE 2 is reproduced the build-up of stripes changes hue from orange to yellow to green, in correspondence with the color bar 8 at the top

of the display. The variations in hues or shadings of the color bar can be based upon various quantification metrics. For example, the mitral valve location of each successive image can be assigned a successive different hue or shade. Thus, each image frame in the sequence uses a successively different hue or shade. Alternatively, each successive hue or shade can correspond to a particular increment of motion such as 0.XX mm. In this embodiment a wide range of colors indicates a large range of motion as the spread of the line or strip build-up shows. As a third alternative, each successive hue or color can represent an increment in time during the heart cycle. Such a gradation can be synchronized to the frame acquisition times, for instance.

[0010] Each time the predetermined heart phase or phases have completed and the mitral valve motion 5 depicted for that heart cycle interval has been fully depicted, the build-up of lines or stripes is deleted until the predetermined phase starts again during a successive heart cycle. If the user decides to depict the mitral valve motion during systole the first line or stripe will be drawn at a lower position on the display and continually move upward as the heart contracts and the mitral valve moves toward the apex of the heart. If the user decides to depict mitral valve motion during diastole the lines or stripes will begin at a higher position on the display and progressively build up toward the bottom of the screen as the heart muscle relaxes and the mitral valve location moves away from the apex. If both heart phases are chosen the build-up of colors or shades will alternately move upward and then downward on the screen.

[0011] Several techniques for detecting the location of the mitral valve in a heart image, a fully automated technique and an assisted automated technique, are described in the '486 application. In the automated technique the ABD processor 490 first locates two key landmarks in the image, the medial mitral annulus (MMA) and the lateral mitral annulus (LMA). This is done by doing a search of areas in the vicinity of the mitral valve plane, comparing areas or volumes of pixels with a template resembling the shapes of the LV where the mitral valve is attached to the septal and lateral walls of the LV. Filter templates defining the anticipated shapes of the MMA and LMA are cross-correlated to the pixels in the MMA and LMA search areas. When this template matching identifies the MMA and LMA in the image a line is drawn connecting the two identified points as illustrated by the line 5 in the image 78 of FIGURE 3. The line 5 is colored or shaded in accordance with the gradation of a color bar for the image as previously described.

[0012] This process may be continued to identify, not only the mitral valve plane, but the complete endocardial border. The septal and lateral walls of the LV are identified by analyzing the transition in grayscale between the heart chamber and the endocardium and the angles of these walls is estimated. A line bisecting the wall angles is calculated and the apex of the LV is estimated on the bisecting line where a pixel intensity change indicates

the endocardial wall at the apex. The apex is identified as the point along a line of pixels where the maximum positive brightness gradient from the LV chamber (where there are substantially no specular reflectors) to the heart wall (where many reflectors are located) is found. Once these three major landmarks of the LV have been located, the MMA, the LMA and the apex, one of a number of predetermined standard shapes for the LV is fitted to the three landmarks and the endocardial wall. When the shape has been fitted to points along the heart wall, the border tracing is smoothed and displayed over the image with a number of control or reference points located along the tracing. These reference points are shown as X's in the image 78 of FIGURE 3, which also shows small squares at the MMA, LMA and apex of the traced endocardial border. The user can adjust the border manually if desired by "grabbing" a reference point with a display pointing tool such as a computer mouse or trackball and dragging the reference point to the desired location. The ABD processor 490 will then recalculate the local border segments to fit the border tracing to the newly located reference point. The technique may be repeated for other images taken during the same heart cycle, which is further aided by using the border tracing of the previous image to quickly find the border of a current image. The technique is applicable to both the endocardial and epicardial borders of the heart. Further details of this border tracing technique may be found in US Pat. 6,491,636 (Chenal et al.)

[0013] In accordance with the principles of the present invention the mitral valve color kinesis technique shown in FIGURE 2 is extended to simultaneously illustrate motion effects at a plurality of regions of the heart, enabling the clinician to effectively diagnose possible cardiac synchronization problems over the heart chamber. FIGURE 4 illustrates an image 76 produced in accordance with the present invention. In this example three lines 10, 12, and 14 are shown extending across the LV 9 of the image. These lines are connected between reference point pairs 11, 13, 15 located on opposite sides of the LV. The reference points are located on the same locations of the endocardium or myocardium through the heart cycle and the lines 10, 12, and 14 between them are continually drawn and accumulated in changing shades or colors as described for the mitral valve above. The lines in FIGURE 4 connect the reference point pairs 11, 13, 15 as they are shown at the instant of the image 76, which is subsequent to an end diastole starting point as shown by time marker 16 on the ECG trace 18 at the bottom of the image. Thus, the accumulated bands of color kinesis 20 show the progression of positions of the lines 10, 12, 14 over the heart cycle from end diastole to the later time of image 76. If the walls of the heart are moving in synchronism the color kinesis bands 20 should be relatively symmetrical trapezoids. In this image it is seen that the two lower bands are approximately symmetrical but that the upper band between reference points 15 is asymmetrical with lesser movement at the lateral wall on the right side

of the image. The clinician may therefore want to conduct more detailed diagnosis of this region of the heart.

[0014] An ultrasound system constructed to produce images such as that of FIGURE 4 is shown in FIGURE 5, which is a detailed block diagram of the portion of the ultrasound system between the image processor 440 and the video processor 470 of FIGURE 1. The image processor 440 produces scanline data of an image which is stored in image data memory 140. A first, starting point image is analyzed by border detection of a heart chamber by an ABD processor 144 as described above and the lines 10, 12, and 14 drawn over the mitral valve plane as described above and between pairs of control or reference points. The illustrated reference points 11, 13, 15 and lines 10, 12, 14 are produced by a graphics processor 148 for overlay over a planar or volumetric image. The image with its graphic overlay are converted to the desired display format by a scan converter 50 and stored in a Cineloop memory 460. The image such as the one shown in FIGURE 4 is then coupled to the video processor 470 for display.

[0015] The lines 10, 12, 14 for successive images can be drawn between the control or reference points on the borders of the successive images. However, in a constructed embodiment, the lines of successive images are drawn between points 11, 13, 15 located on successive images by tracking the starting anatomical positions by the speckle pattern produced by the local tissue. The locations of the reference points 11, 13, 15 in the initial image (e.g., end diastole image) are coupled from the ABD processor 144 to a speckle tracker 142, which identifies regions of pixels around the reference points in the adjacent myocardium. The speckle patterns of these pixels is saved and compared with speckle patterns in the same regions of the successive images and the speckle patterns matched by block matching. The difficulty and precision of the matching is determined by setting a correlation coefficient for the matching. The reference point locations in the images are thus tracked from image to image by following the speckle patterns around the points. When the speckle tracker 142 locates the reference points 11, 13, 15 in a new image the reference point locations are coupled to the graphics processor 148, the color lines produced and accumulated with the previously determined lines and a graphic overlay produced for the new image. The new image and its graphic overlay are scan converted and displayed on an image display which will produce an image such as image 76 of FIGURE 4. The clinician can use the displayed motional information to identify problems of cardiac motion and synchronicity.

[0016] Instead of tracking the speckle pattern of the myocardial tissue surrounding, underlying, or adjacent to the reference points, it may be appreciated that the reference point locations may be tracked by means other than speckle tracking, that is, by tracking image characteristics which are greater than a wavelength in size. For instance, the movement of specific anatomical features may be tracked. As another example, tissue texture may

be tracked. It will also be appreciated that the targeted characteristics may be tracked in either pre-scan converted or post-scan converted image data.

[0017] FIGURE 6 illustrates another image 74 produced in accordance with the principles of the present invention. In this example the clinician has elected to use ten pairs of reference points, which is done by selecting ten pairs from the control panel 150 of the ultrasound system in FIGURE 5. This reference point data is stored at 146 and applied to the ABD processor 144 and speckle tracker 142, which set the number of pairs of reference points in the initial image and track the points through subsequent images. The reference points are by default distributed at uniformly spaced distances along the heart border, but the positions can also be adjusted manually by the clinician by pointing and dragging as discussed above. The example of FIGURE 6 illustrates abnormal wall motion and possible synchronization problems. The color kinesis band 22 near the apex of the heart is seen to have very little height on the right side, resulting from little motion of the lateral wall of the heart at that location. The color kinesis band 24 near the mitral valve is seen to have only a very slight excursion at the septal wall on the left side of the heart chamber. This heart may thus be a candidate for more extensive diagnosis and analysis.

[0018] The diagnostic tools of the present invention can be used for other chambers of the heart such as the right ventricle (RV) 3 as illustrated in the example of FIGURE 7. In this example the color kinesis bands 20 reveal greater lateral motion of the RV as compared to the motion of the septum 4.

[0019] The diagnostic tools of the present invention are applicable to transverse views of the heart in addition to the previously illustrated longitudinal views. FIGURE 8 is a transverse view across the left ventricle 9 with the reference points 11 dispersed around the perimeter of the heart chamber. The lines 10 are drawn between pairs of points 11 as the locations of the points are followed by speckle tracking over the heart cycle. The positions of the lines 10 are accumulated as color kinesis bands 20. The positions of the bands with reference to the lines, such as band 26 with respect to line 27 between points 25, show a twisting motion of the heart. Since the heart is approximately a helically wound bundle of muscle fibers, there is a distinct twist to its motion as it beats, which is revealed in the example of FIGURE 8.

[0020] FIGURE 9 is an example of an image of the present invention in which reference points 11 are located along the endocardium and reference points 19 are located along the epicardium in the same transverse image of the heart. Lines 30 are drawn and their changing positions represented in color kinesis bands 30 along the endocardial and epicardial borders in the image. In addition, lines 32 are drawn across the myocardium and tracked as bands 42 in the image. Thus, the motion of several parts of the heart anatomy is tracked in different directions at the same time.

[0021] FIGURE 10 is another example of the tracking of motion in different directions in the same image. In this example lines 60 are drawn in approximately parallel orientations between one set of reference points 61 and another group of lines 64 are drawn between reference points 65. Motion of the myocardium in approximately orthogonal directions is thus depicted in the same image.

[0022] It will also be apparent to those skilled in the art that quantified numerical measures or representations of the excursions of lines between reference points can be derived from the color coding or spacing of the successive line locations. Both heart wall positions and rates of change in position (derivatives of positional change or velocity) can be displayed to assist in the diagnosis. The presentation of color kinesis bands at different locations across the chamber enables the clinician to make comparative diagnoses of the motion at different locations in the chamber. It will be appreciated that the techniques of the present invention are also applicable to three dimensional images, in which the lines can appear as surfaces and the color kinesis bands as 3D regions of color-depicted locational change. In order to enable the clinician to see both the anatomy and the motion of the reference points, the volumes formed by the accumulation of surfaces during the heart cycle may be display semi-transparently so that the clinician can visualize anatomy behind the colored volumes.

[0023] It will be appreciated that, instead of or in addition to showing the motion of the heart wall in a color or shaded representation, the motion may also be indicated in a quantified form. Motion may be indicated numerically in distance or velocity units and the direction (vector) of the motion may be displayed.

[0024] Variations of the examples described above are also within the scope of the present invention. For instance, instead of identifying the starting locations of the reference points through automated or semi-automated border detection, the points can be placed manually on the starting image by the clinician using a pointing device such as a computer mouse or trackball. The selected tracking method (speckle, feature, texture or other) may then be used to track the locations of the manually placed reference points through the sequence of images.

Claims

1. A method for depicting the functioning of the heart from a sequence of images acquired during a phase of a heart cycle comprising:

acquiring a sequence of images of the heart during a selected phase or phases of the heart cycle;

identifying in a heart image the locations of reference points on opposite sides of a chamber of the heart;

tracking positions of the reference points during

the selected phase or phases of the heart cycle; producing at least one line across the chamber of the heart, wherein said line is referenced to a pair of the identified points spaced along opposite sides;

characterized in that

the method further comprises

accumulating positional changes of the line during the selected phase or phases of the heart cycle, based on the tracked changes in the positions of the referenced points;

and

displaying the accumulated changes of the positions of the lines during the selected phase or phases of the heart cycle.

2. The method of Claim 1, wherein displaying further comprises displaying the accumulated changes of the positions of the lines in different colors.
3. The method of Claim 2, wherein acquiring comprises acquiring a sequence of three dimensional images of the heart, wherein the lines comprise surfaces.
4. The method of Claim 1, wherein tracking further comprises tracking the reference points during the selected phase or phases of the heart cycle by speckle tracking.
5. The method of Claim 4, wherein speckle tracking further comprises tracking the speckle pattern of myocardial tissue located in the vicinity of the reference points from one image to another.
6. The method of Claim 5, wherein identifying comprises identifying the locations of reference points on an identified border of the chamber of the heart.
7. The method of Claim 6, wherein identifying further comprises identifying the border of the chamber of the heart by automated border detection.
8. The method of Claim 1, wherein tracking further comprises tracking the reference points during the selected phase or phases of the heart cycle by automated border detection of successive heart images.
9. The method of Claim 1, wherein tracking further comprises tracking the reference points during the selected phase or phases of the heart cycle by feature tracking.
10. The method of Claim 1, wherein tracking further comprises tracking the reference points during the selected phase or phases of the heart cycle by texture

tracking.

11. The method of Claim 1, wherein displaying comprises displaying the motion of the reference points quantitatively.

5

12. An ultrasonic diagnostic imaging system for diagnosing the synchronicity of cardiac motion comprising:

an ultrasound probe (410);
an image processor (440);
a border detector operable to identify points on opposite sides of a heart chamber in an ultrasound image;

10

a speckle tracker (142) operable to track the changes in the positions of the points during at least a portion of a cardiac cycle;
a display processor; and
a graphics processor (148) arranged to produce at least one line across the chamber of the heart, said line being referenced to a pair of the identified points spaced along opposite sides,

15

characterized in that

the graphics processor is further arranged to accumulate the positional changes of the line based on the tracked changes in the positions of the referenced points; wherein the display processor is arranged to display the accumulated changes of the positions of the line after at least a portion of a heart cycle.

20

25

30

13. The ultrasonic diagnostic imaging system of Claim 12, further comprising a scan converter (50) for scan converting ultrasonic image data into a desired display format, wherein the speckle tracker is operable to track changes in the positions of the points in image data prior to scan conversion.

35

14. The ultrasonic diagnostic imaging system of Claim 12, wherein the border detector comprises a manual user input by which points can be manually placed on opposite sides of a heart chamber in the ultrasound image.

40

Patentansprüche

1. Verfahren zur Darstellung der Funktionsweise des Herzens anhand einer während einer Phase eines Herzzyklus erfassten Bildsequenz, wobei das Verfahren Folgendes umfasst:

50

Erfassen einer Sequenz von Bildern des Herzens während einer ausgewählten Phase oder Phasen des Herzzyklus;
Identifizieren der Orte von Referenzpunkten auf gegenüberliegenden Seiten einer Herzkammer

55

in einem Herzbild;

Verfolgen von Positionen der Referenzpunkte während der ausgewählten Phase oder Phasen des Herzzyklus;

Erzeugen von mindestens einer Linie quer durch die Herzkammer, wobei die genannte Linie auf ein Paar von identifizierten Punkten referenziert ist, die entlang gegenüberliegender Seiten beabstandet sind;

dadurch gekennzeichnet, dass das Verfahren weiterhin Folgendes umfasst:

Kumulieren von Positionsänderungen der Linie während der ausgewählten Phase oder Phasen des Herzzyklus basierend auf den verfolgten Positionsänderungen der referenzierten Punkte;
und

Anzeigen der kumulierten Positionsänderungen der Linien während der ausgewählten Phase oder Phasen des Herzzyklus.

2. Verfahren nach Anspruch 1, wobei das Anzeigen weiterhin das Anzeigen der kumulierten Positionsänderungen der Linien in verschiedenen Farben umfasst.

3. Verfahren nach Anspruch 2, wobei das Erfassen das Erfassen einer Sequenz von dreidimensionalen Bildern des Herzens umfasst, wobei die Linien Oberflächen umfassen.

4. Verfahren nach Anspruch 1, wobei das Verfolgen weiterhin das Verfolgen von Referenzpunkten während der ausgewählten Phase oder Phasen des Herzzyklus durch Speckle-Verfolgung umfasst.

5. Verfahren nach Anspruch 4, wobei die Speckle-Verfolgung weiterhin das Verfolgen des Speckle-Musters von Myokardgewebe, das sich in der Nähe der Referenzpunkte befindet, von einem Bild zum andern umfasst.

6. Verfahren nach Anspruch 5, wobei das Identifizieren das Identifizieren der Orte von Referenzpunkten an einem identifizierten Rand der Herzkammer umfasst.

7. Verfahren nach Anspruch 6, wobei das Identifizieren weiterhin das Identifizieren des Rands der Herzkammer durch automatisierte Randdetektion umfasst.

8. Verfahren nach Anspruch 1, wobei das Verfolgen weiterhin das Verfolgen der Referenzpunkte während der ausgewählten Phase oder Phasen des Herzzyklus durch automatisierte Randdetektion von aufeinanderfolgenden Herzbildern umfasst.

9. Verfahren nach Anspruch 1, wobei das Verfolgen weiterhin das Verfolgen der Referenzpunkte während der ausgewählten Phase oder Phasen des Herzzyklus durch Merkmalsverfolgung umfasst.

5

10. Verfahren nach Anspruch 1, wobei das Verfolgen weiterhin das Verfolgen der Referenzpunkte während der ausgewählten Phase oder Phasen des Herzzyklus durch Texturverfolgung umfasst.

10

11. Verfahren nach Anspruch 1, wobei das Anzeigen das quantitative Anzeigen der Bewegung der Referenzpunkte umfasst.

12. Ultraschallsystem zur diagnostischen Bildgebung zum Diagnostizieren der Synchronizität von Herzbe-
wegung, wobei das Ultraschallsystem Folgendes umfasst:

15

eine Ultraschallsonde (410);
einen Bildprozessor (440);
einen Randdetektor, der betriebsfähig ist, um Punkte auf gegenüberliegenden Seiten einer Herzkammer in einem Ultraschallbild zu identifizieren;
einen Speckle-Verfolger (142), der betriebsfähig ist, um die Positionsänderungen der Punkte während mindestens eines Teils eines Herzzyklus zu verfolgen;
einen Anzeigeprozessor; und
einen Grafikprozessor (148), der dafür vorgesehen ist, mindestens eine Linie quer durch die Herzkammer zu erzeugen, wobei die genannte Linie auf ein Paar von identifizierten Punkten referenziert ist, die entlang gegenüberliegender Seiten beabstandet sind,

20

25

30

35

dadurch gekennzeichnet, dass

der Grafikprozessor weiterhin dafür vorgesehen ist, die Positionsänderungen der Linie basierend auf den verfolgten Positionsänderungen der referenzierten Punkte zu kumulieren; wobei der Anzeigeprozessor dafür vorgesehen ist, die kumulierten Positionsänderungen der Linie nach mindestens einem Teil des Herzzyklus anzuzeigen.

40

45

13. Ultraschallsystem zur diagnostischen Bildgebung nach Anspruch 12, weiterhin umfassend einen Scan-Konverter (50) zum Scan-Konvertieren von Ultraschalldaten in ein gewünschtes Anzeigeformat, wobei der Speckle-Verfolger betriebsfähig ist, um Positionsänderungen der Punkte in Bilddaten vor der Scan-Konvertierung zu verfolgen.

50

55

14. Ultraschallsystem zur diagnostischen Bildgebung nach Anspruch 12, wobei der Randdetektor eine ma-

nuelle Benutzereingabe umfasst, durch die Punkte in dem Ultraschallbild manuell auf gegenüberliegenden Seiten einer Herzkammer platziert werden können.

Revendications

1. Procédé de représentation du fonctionnement du coeur, à partir d'une séquence d'images acquises pendant une phase d'un cycle cardiaque, comprenant :

l'acquisition d'une séquence d'images du coeur pendant une ou des phases sélectionnée(s) du cycle cardiaque ;

l'identification dans une image cardiaque des emplacements de points de repère, sur les côtés opposés d'une cavité cardiaque ;

le suivi des positions des points de repère pendant la ou les phases sélectionnées du cycle cardiaque ;

la production d'au moins une ligne à travers la cavité cardiaque, dans laquelle ladite ligne est référencée selon une paire des points identifiés espacés le long de côtés opposés ;

caractérisé en ce que

le procédé comprend en outre

le cumul des changements de position de la ligne, pendant la ou les phases sélectionnées du cycle cardiaque, sur la base des changements suivis des positions des points de repère ;

et

l'affichage des changements cumulés des positions des lignes pendant la ou les phases sélectionnées du cycle cardiaque.

2. Procédé selon la revendication 1, dans lequel l'affichage comprend en outre l'affichage des changements cumulés des positions des lignes dans différentes couleurs.

3. Procédé selon la revendication 2, dans lequel l'acquisition comprend l'acquisition d'une séquence d'images en trois dimensions du coeur, dans lequel les lignes comprennent des surfaces.

4. Procédé selon la revendication 1, dans lequel le suivi comprend en outre le suivi des points de repère pendant la ou les phases sélectionnées du cycle cardiaque par un suivi du chatoiement.

5. Procédé selon la revendication 4, dans lequel le suivi du chatoiement comprend le suivi du motif de chatoiement du tissu myocardique situé à proximité des points de repère, d'une image à une autre.

6. Procédé selon la revendication 5, dans lequel l'iden-

tification comprend l'identification des emplacements des points de repère sur un contour identifié de la cavité cardiaque.

7. Procédé selon la revendication 6, dans lequel l'identification comprend en outre l'identification du contour de la cavité cardiaque par une détection de contour automatisée. 5
8. Procédé selon la revendication 1, dans lequel le suivi comprend en outre le suivi des points de repère pendant la ou les phases sélectionnées du cycle cardiaque, par une détection de contour automatisée d'images cardiaques successives. 10
9. Procédé selon la revendication 1, dans lequel le suivi comprend en outre le suivi des points de repère pendant la ou les phases sélectionnées du cycle cardiaque par un suivi des fonctions. 15
10. Procédé selon la revendication 1, dans lequel le suivi comprend en outre le suivi des points de repère pendant la ou les phases sélectionnées du cycle cardiaque par un suivi de la texture. 20
11. Procédé selon la revendication 1, dans lequel l'affichage comprend l'affichage du mouvement des points de repère quantitativement. 25
12. Système d'imagerie diagnostique à ultrasons pour diagnostiquer la synchronicité du mouvement cardiaque, comprenant : 30
- une sonde à ultrasons (410) ;
 - un processeur d'image (440) ; 35
 - un détecteur de contour pouvant être actionné pour identifier des points sur des côtés opposés d'une cavité cardiaque, dans une image à ultrasons ;
 - un système de suivi du chatoiement (142) pouvant être actionné pour suivre les changements de positions des points pendant au moins une partie du cycle cardiaque : 40
 - un processeur d'affichage ; et 45
 - un processeur graphique (148) disposé de façon à produire au moins une ligne à travers la cavité cardiaque, ladite ligne étant référencée selon une paire des points identifiés espacés le long des côtés opposés, 50
- caractérisé en ce que**
- le processeur graphique est en outre disposé de façon à cumuler les changements de position de la ligne, sur la base des changements suivis dans les positions des points de repère ; dans lequel le processeur d'affichage est disposé de façon à afficher les changements cumulés des positions de 55

la ligne après au moins une partie d'un cycle cardiaque.

13. Système d'imagerie diagnostique à ultrasons selon la revendication 12, comprenant en outre un convertisseur de balayage (50) pour convertir le balayage des données d'images à ultrasons en un format d'affichage souhaité, dans lequel le système de suivi de chatoiement peut être actionné pour suivre les changements des positions des points dans les données de l'image avant la conversion de balayage.
14. Système d'imagerie diagnostique à ultrasons selon la revendication 12, dans lequel le détecteur de contour comprend une entrée manuelle de l'utilisateur, moyennant quoi les points peuvent être manuellement placés sur des côtés opposés d'une cavité cardiaque dans l'image à ultrasons.

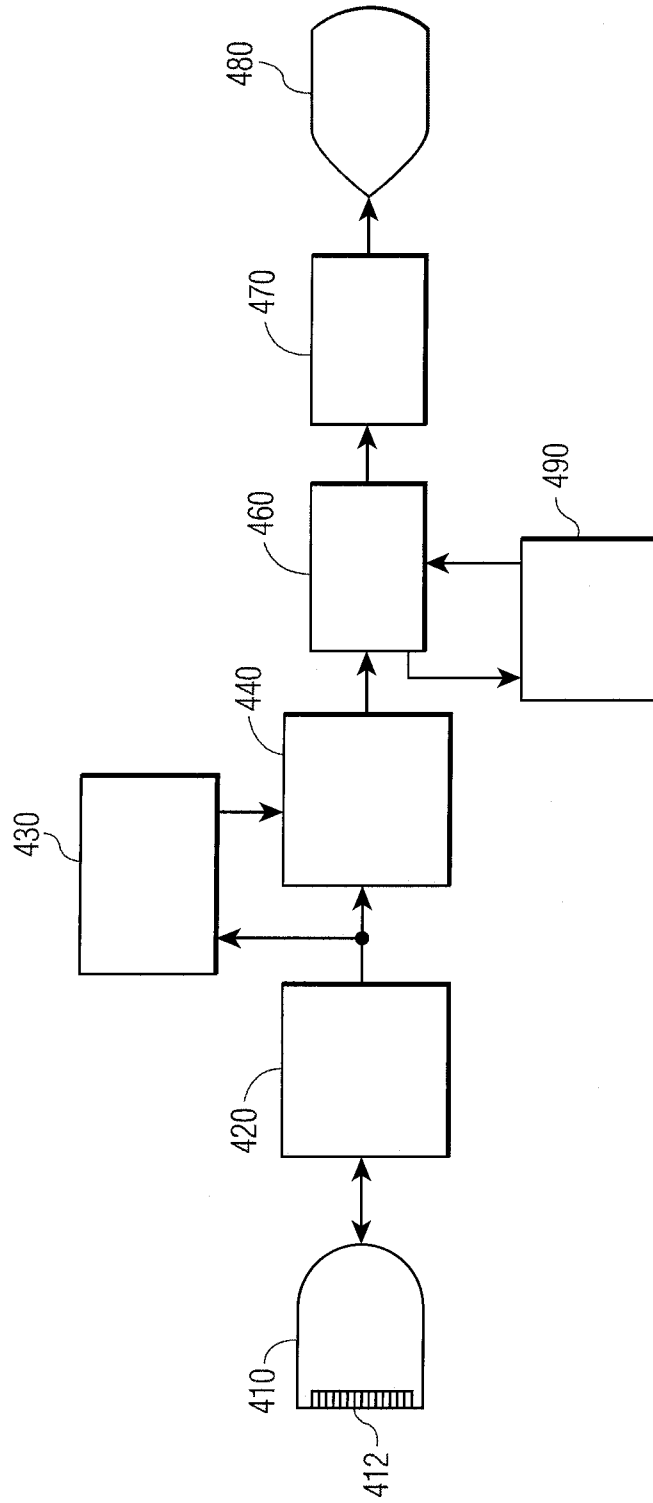

FIG. 1

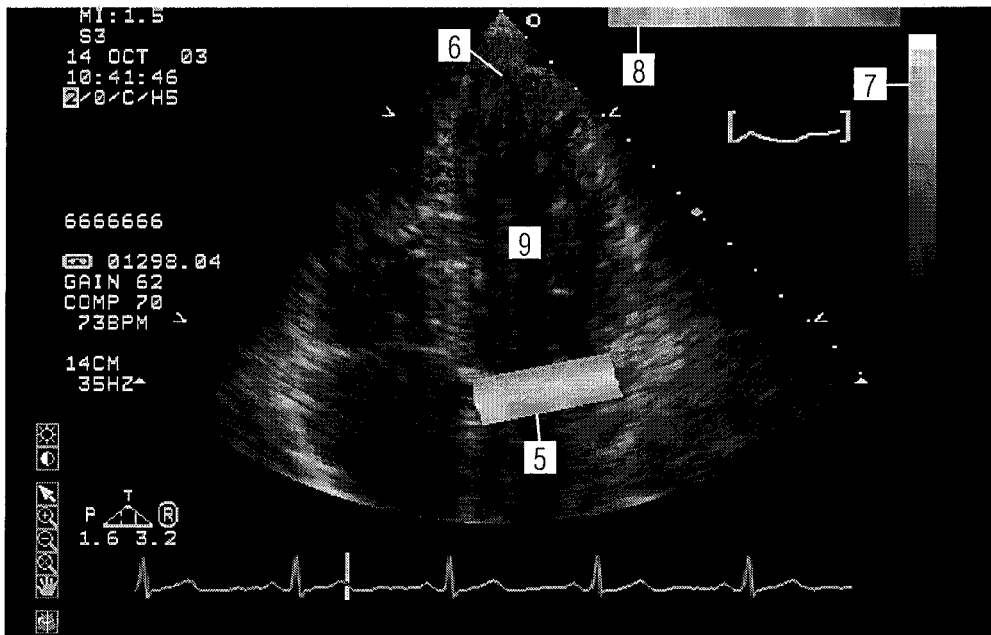

FIG. 2

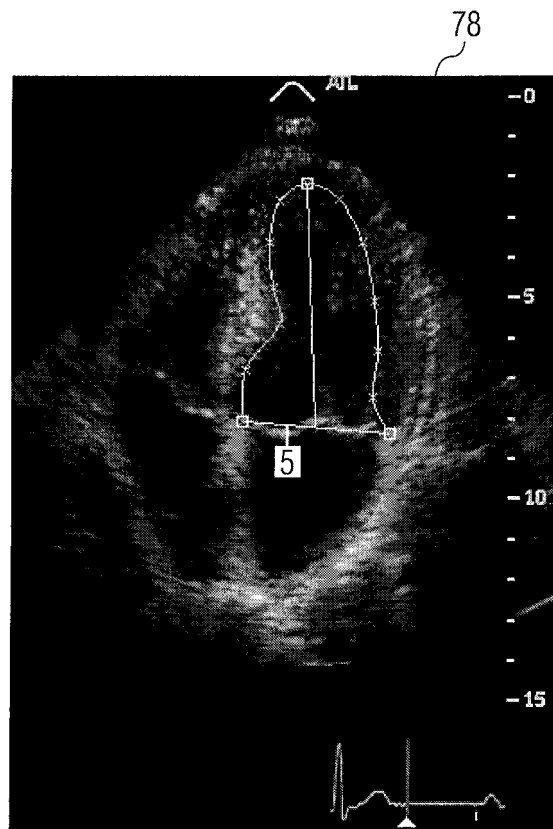

FIG. 3

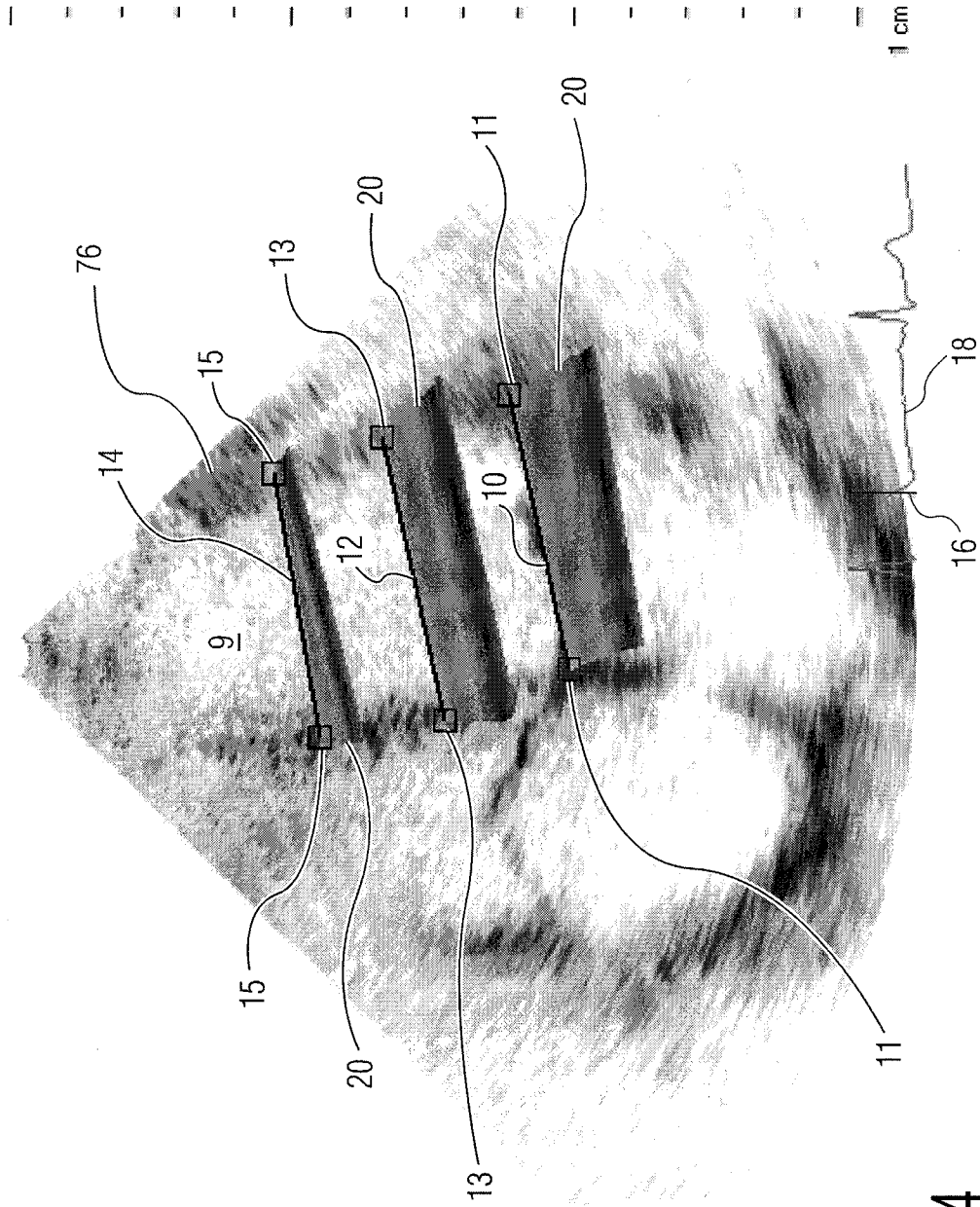

FIG. 4

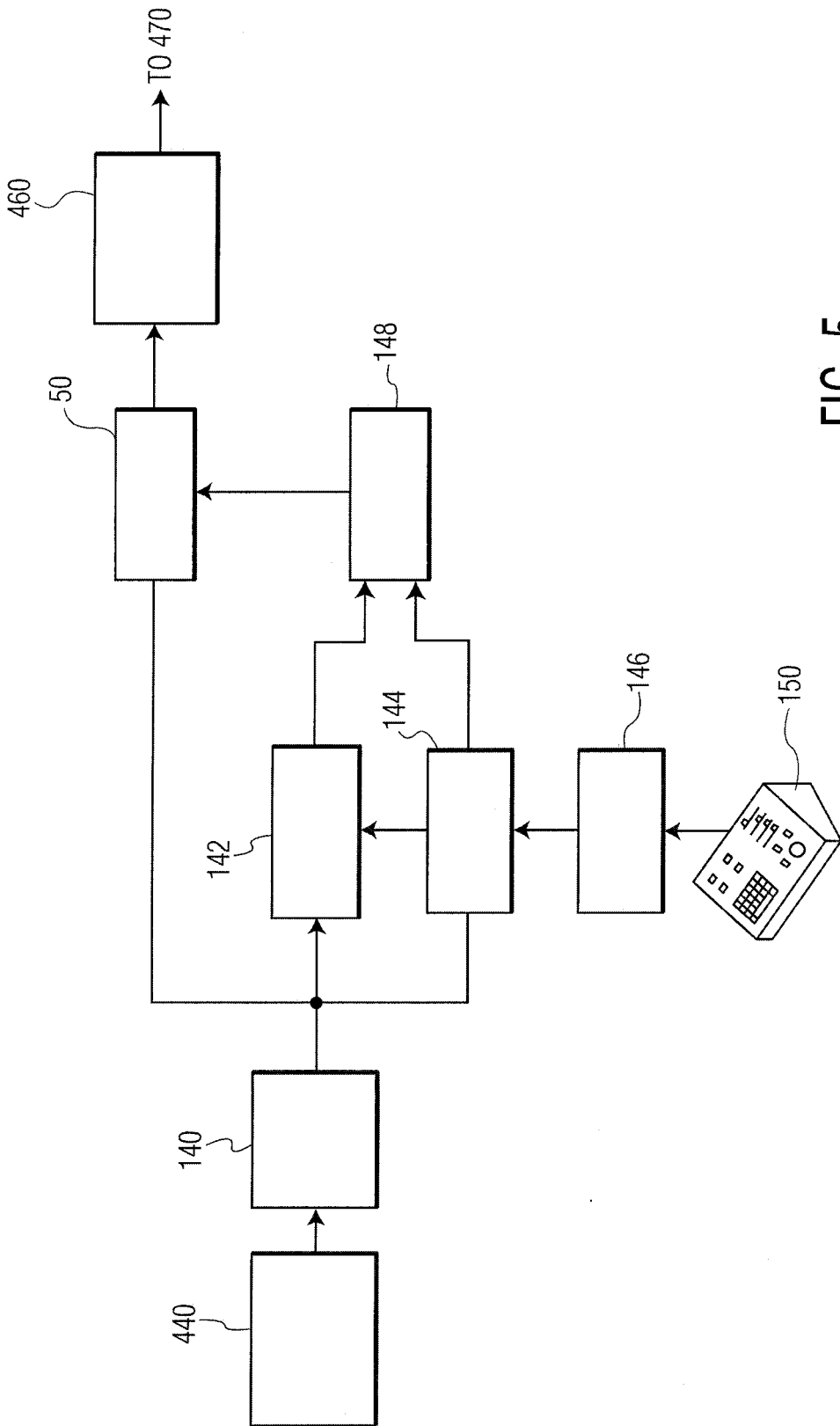

FIG. 5

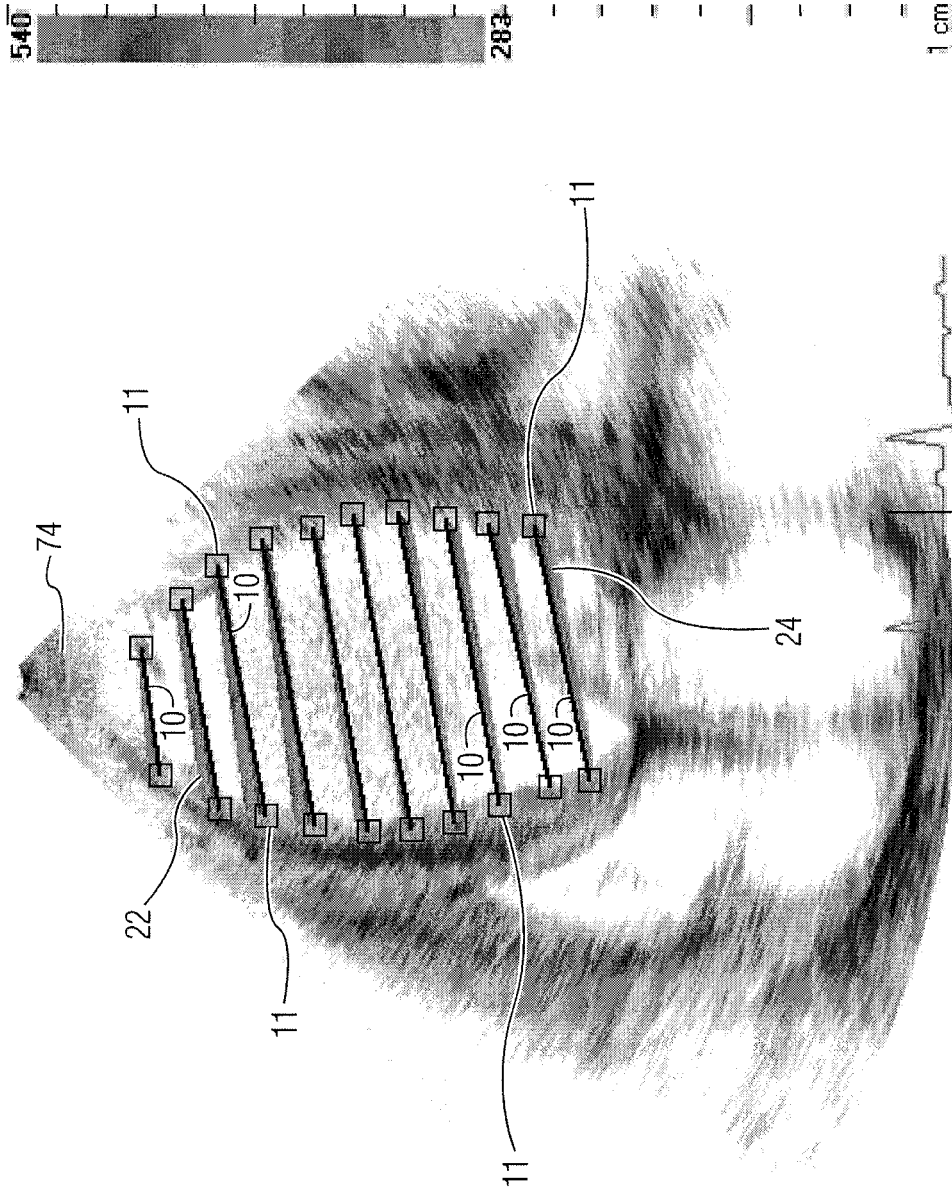

FIG. 6

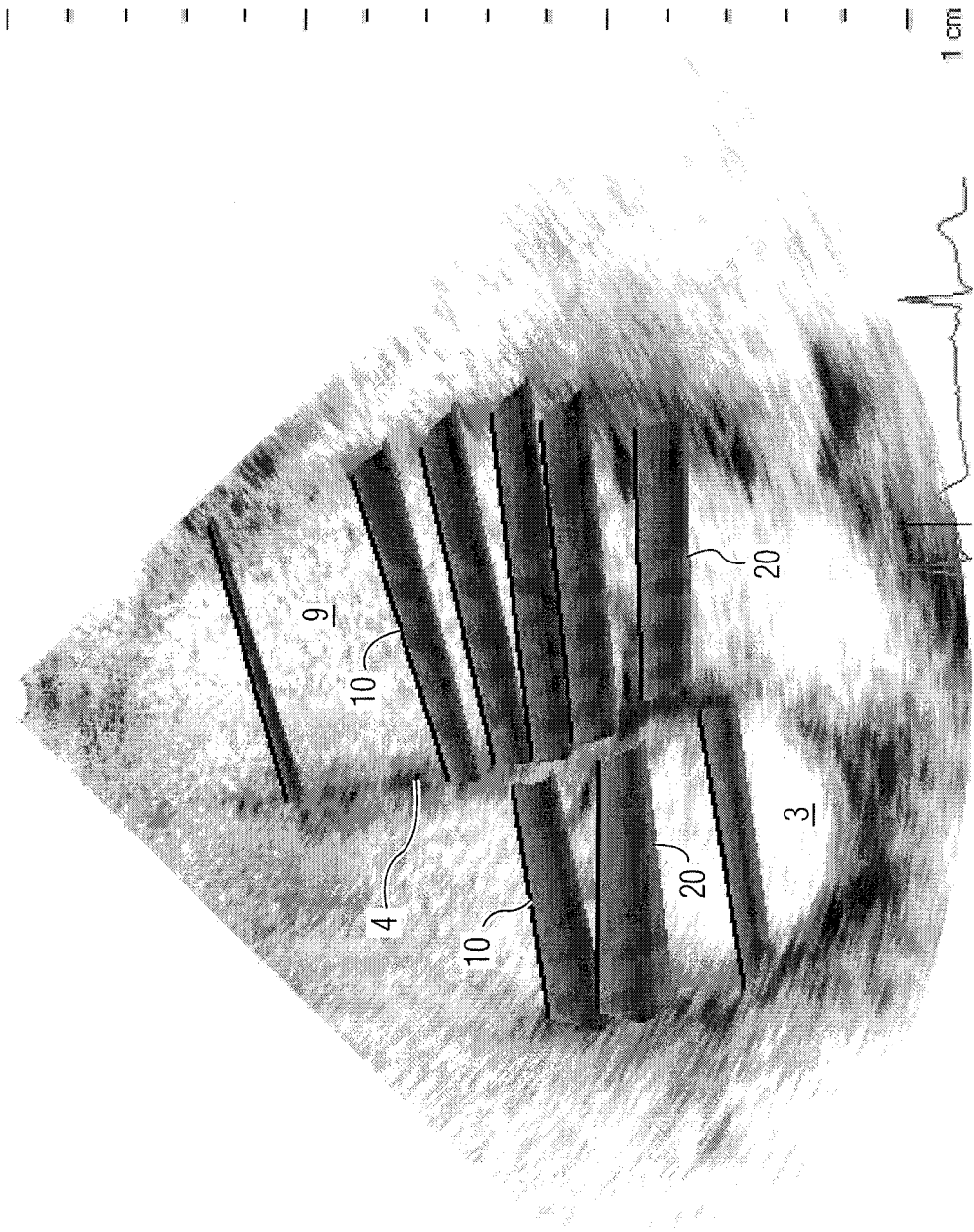
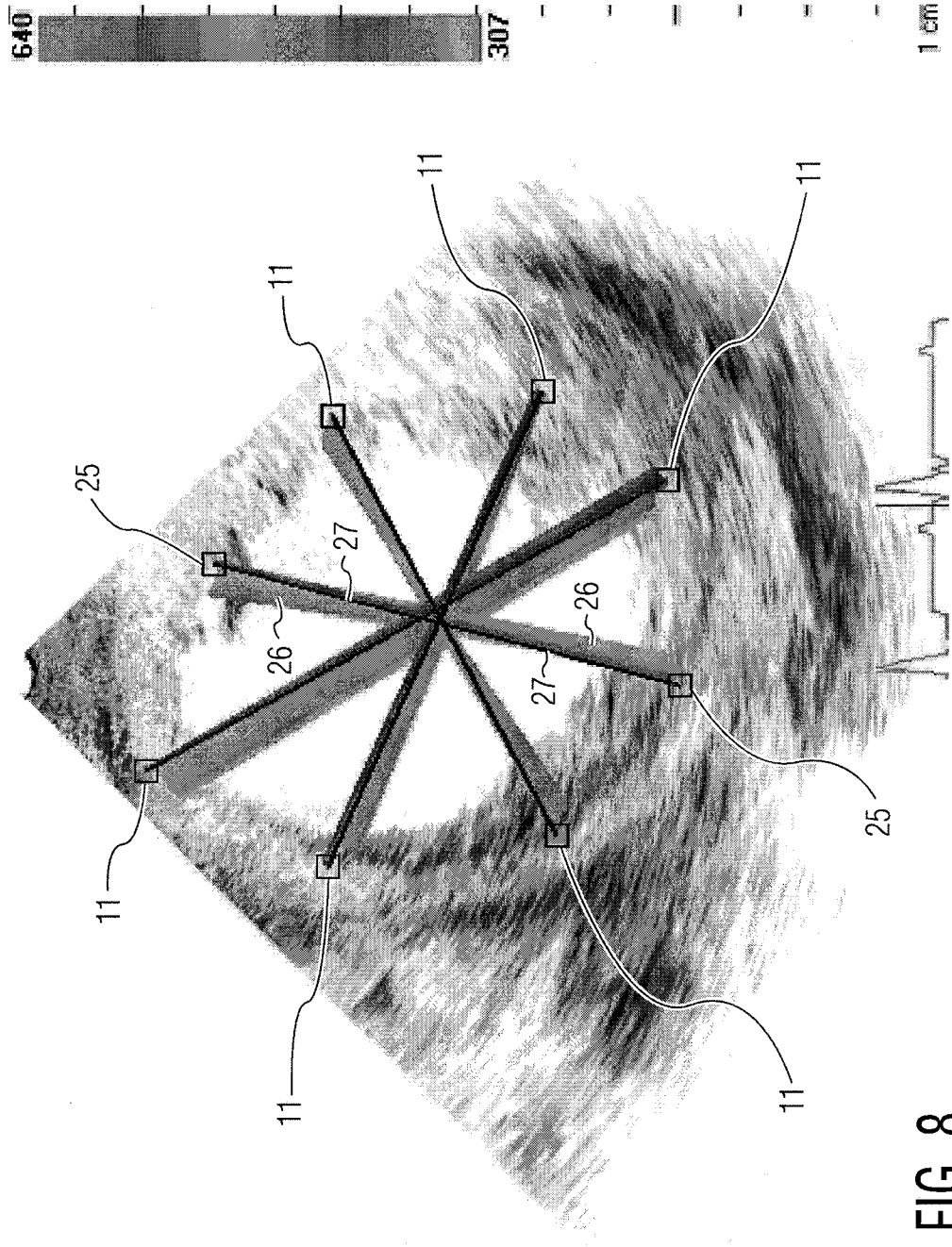

FIG. 7



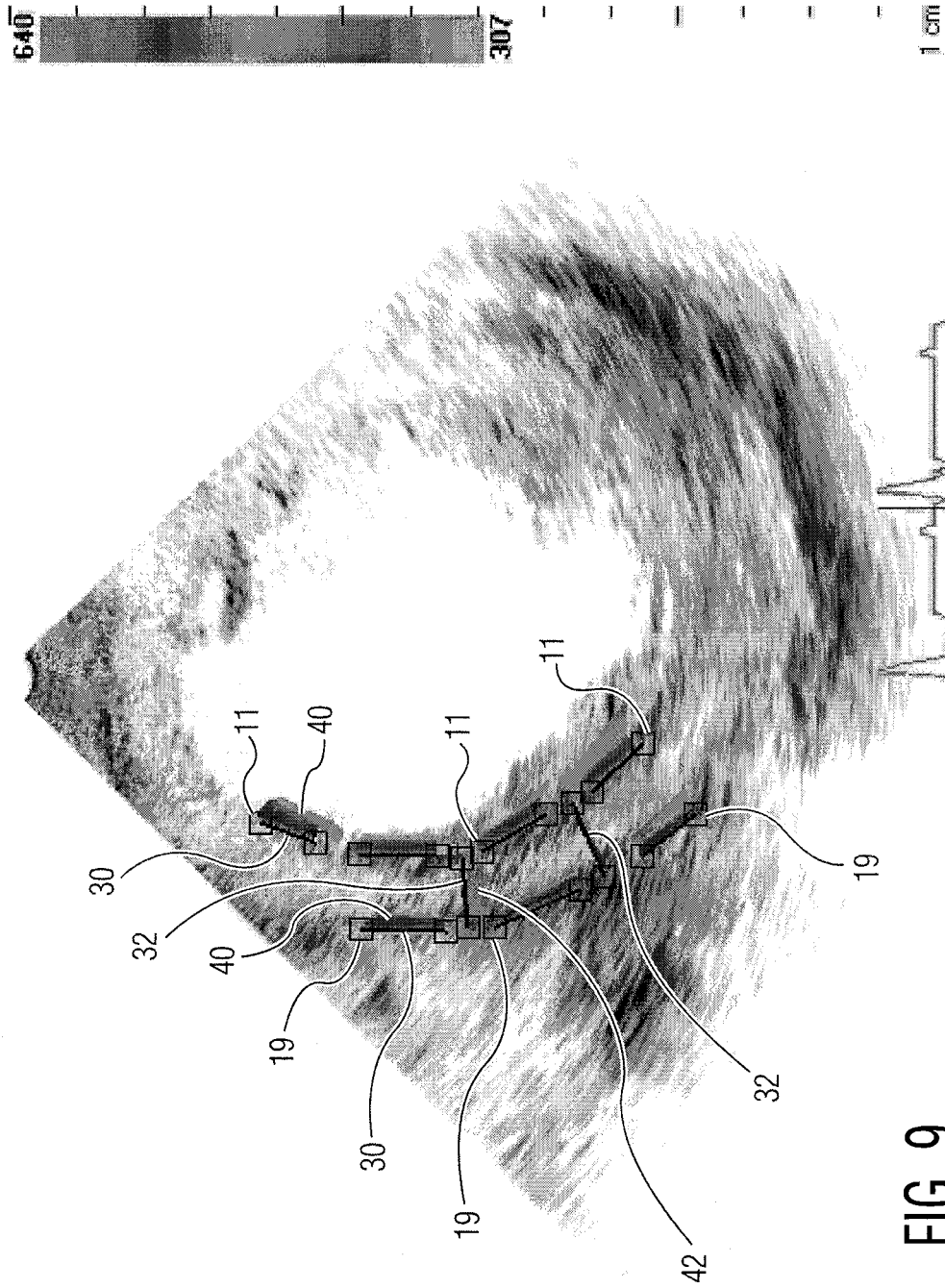

FIG. 9

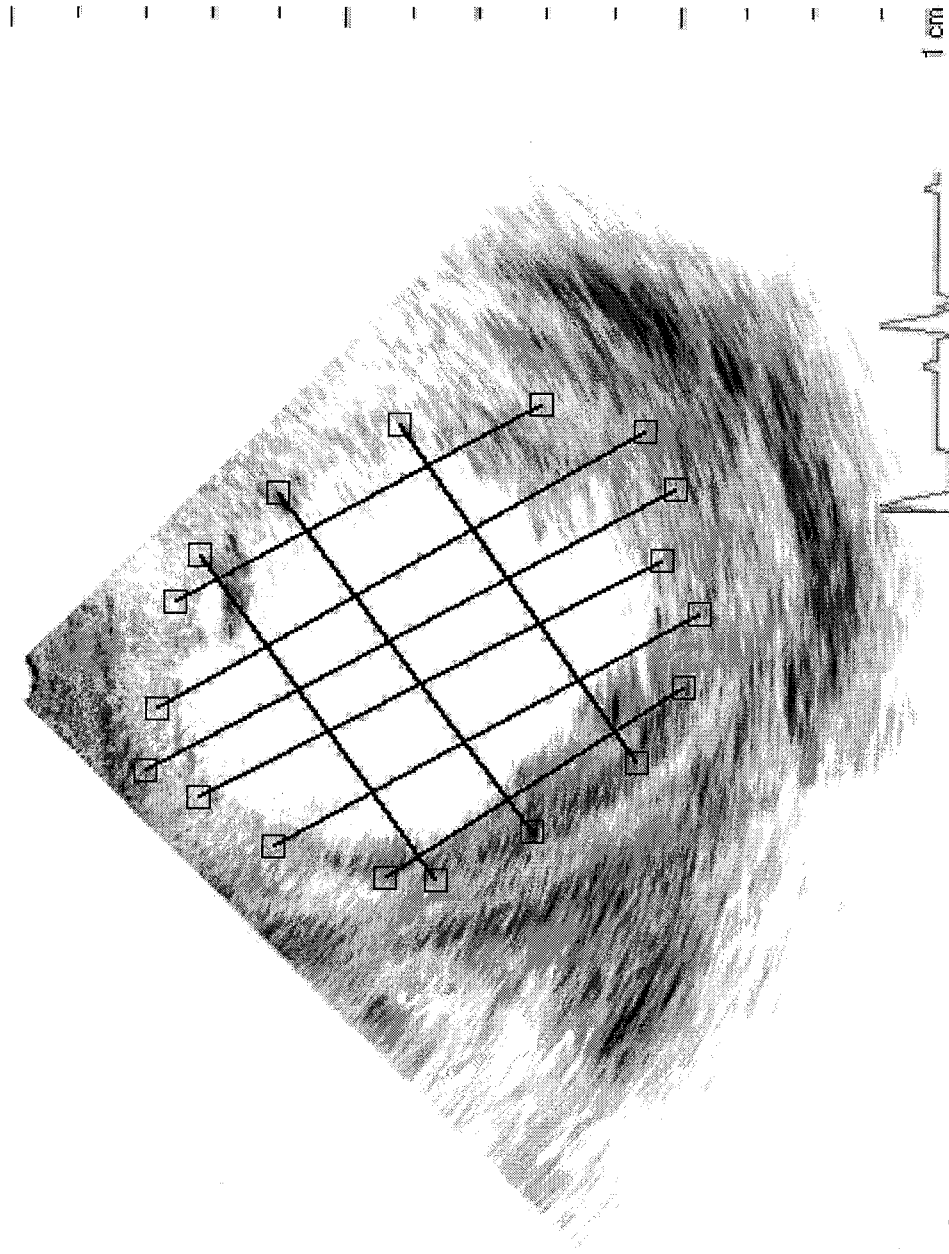

FIG. 10

REFERENCES CITED IN THE DESCRIPTION

This list of references cited by the applicant is for the reader's convenience only. It does not form part of the European patent document. Even though great care has been taken in compiling the references, errors or omissions cannot be excluded and the EPO disclaims all liability in this regard.

Patent documents cited in the description

- US 20020072671 A1 [0003]
- WO 2006024970 A [0009]
- US 6491636 B, Chenal [0012]

专利名称(译)	超声诊断心肌同步		
公开(公告)号	EP1948025B1	公开(公告)日	2018-01-10
申请号	EP2006821296	申请日	2006-11-02
[标]申请(专利权)人(译)	皇家飞利浦电子股份有限公司		
申请(专利权)人(译)	皇家飞利浦电子N.V.		
当前申请(专利权)人(译)	皇家飞利浦N.V.		
[标]发明人	SALGO IVAN SETTLEMIER SCOTT PRATER DAVID		
发明人	SALGO, IVAN SETTLEMIER, SCOTT PRATER, DAVID		
IPC分类号	A61B8/08		
CPC分类号	A61B8/08 A61B8/0883 G06T7/251 G06T2207/10132 G06T2207/30048		
代理机构(译)	德哈恩波尔ERIK		
优先权	60/734662 2005-11-08 US		
其他公开文献	EP1948025A2		
外部链接	Espacenet		

摘要(译)

描述了一种用于检测心壁刺激同步性异常的超声诊断成像方法和系统。在起始超声图像中识别心脏腔室的相对侧上的点，然后通过心脏周期的至少一部分进行跟踪。在各对点之间延伸的线的变化位置被累积并显示在彩色运动显示中，其中每种颜色描绘了心动周期中特定点处的线的位置。在示出的示例中，通过相邻心肌组织的散斑图案的斑点追踪，跟踪特定解剖结构或跟踪组织纹理，通过心动周期跟踪点。

