

(19)



(11)

EP 2 627 257 B1

(12)

EUROPEAN PATENT SPECIFICATION

(45) Date of publication and mention of the grant of the patent:
17.04.2019 Bulletin 2019/16

(51) Int Cl.:
A61B 8/00 (2006.01) A61B 8/08 (2006.01)
A61B 8/14 (2006.01) B06B 1/06 (2006.01)
G01S 7/52 (2006.01) G01S 15/89 (2006.01)

(21) Application number: **11833340.0**

(86) International application number:
PCT/US2011/055976

(22) Date of filing: **12.10.2011**

(87) International publication number:
WO 2012/051308 (19.04.2012 Gazette 2012/16)

(54) **CONCAVE ULTRASOUND TRANSDUCERS AND 3D ARRAYS**

KONKAVE ULTRASCHALLWANDLER UND 3D-ARRAYS

TRANSDUCTEURS À ULTRASONNS CONCAVES ET RÉSEAUX 3D

(84) Designated Contracting States:
AL AT BE BG CH CY CZ DE DK EE ES FI FR GB GR HR HU IE IS IT LI LT LU LV MC MK MT NL NO PL PT RO RS SE SI SK SM TR

- **CABRERA, Linda, V.**
Sunnyvale, CA 94089 (US)
- **BREWER, Kenneth, D.**
Sunnyvale, CA 94089 (US)
- **SPECHT, David, J.**
Sunnyvale, CA 94089 (US)

(30) Priority: **13.10.2010 US 392896 P**

(43) Date of publication of application:
21.08.2013 Bulletin 2013/34

(74) Representative: **Potter Clarkson**
The Belgrave Centre
Talbot Street
Nottingham NG1 5GG (GB)

(73) Proprietor: **Maui Imaging, Inc.**
Sunnyvale, CA 94089 (US)

(56) References cited:
JP-A- 2001 245 884 US-A- 5 797 845
US-A1- 2005 113 694 US-A1- 2005 124 883
US-A1- 2008 103 393 US-B1- 7 497 828

- (72) Inventors:
- **SMITH, David, M.**
Sunnyvale, CA 94089 (US)
 - **SPECHT, Donald, F.**
Sunnyvale, CA 94089 (US)

EP 2 627 257 B1

Note: Within nine months of the publication of the mention of the grant of the European patent in the European Patent Bulletin, any person may give notice to the European Patent Office of opposition to that patent, in accordance with the Implementing Regulations. Notice of opposition shall not be deemed to have been filed until the opposition fee has been paid. (Art. 99(1) European Patent Convention).

Description

FIELD

[0001] The present invention relates generally to imaging techniques used in medicine, and more particularly to medical ultrasound, and still more particularly to an apparatus for producing ultrasonic images using multiple apertures.

BACKGROUND

[0002] In conventional ultrasonic imaging, a focused beam of ultrasound energy is transmitted into body tissues to be examined and the returned echoes are detected and plotted to form an image. In echocardiography, the beam is usually stepped in increments of angle from a center probe position, and the echoes are plotted along lines representing the paths of the transmitted beams. In abdominal ultrasonography, the beam is usually stepped laterally, generating parallel beam paths, and the returned echoes are plotted along parallel lines representing these paths.

[0003] The basic principles of conventional ultrasonic imaging are described in the first chapter of Echocardiography, by Harvey Feigenbaum (Lippincott Williams & Wilkins, 5th ed., Philadelphia, 1993). It is well known that the average velocity v of ultrasound in human tissue is about 1540 m/sec, the range in soft tissue being 1440 to 1670 m/sec (P. N. T. Wells, Biomedical Ultrasonics, Academic Press, London, New York, San Francisco, 1977). Therefore, the depth of an impedance discontinuity generating an echo can be estimated as the round-trip time for the echo multiplied by $v/2$, and the amplitude is plotted at that depth along a line representing the path of the beam. After this has been done for all echoes along all beam paths, an image is formed. The gaps between the scan lines are typically filled in by interpolation.

[0004] In order to insonify the body tissues, a beam formed by an array of transducer elements is scanned over the tissues to be examined. Traditionally, the same transducer array is used to detect the returning echoes. The use of the same transducer array to both produce the beam and detect returning echoes is one of the most significant limitations in the use of ultrasonic imaging for medical purposes; this limitation produces poor lateral resolution. Theoretically, the lateral resolution could be improved by increasing the aperture of the ultrasonic probe, but the practical problems involved with aperture size increase have kept apertures small and lateral resolution diminished. Unquestionably, ultrasonic imaging has been very useful even with this limitation, but it could be more effective with better resolution.

[0005] In the practice of cardiology, for example, the limitation on single aperture size is dictated by the space between the ribs (the intercostal spaces). For scanners intended for abdominal and other use, the limitation on aperture size is a serious limitation as well. The problem

is that it is difficult to keep the elements of a large aperture array in phase because the speed of ultrasound transmission varies with the type of tissue between the probe and the area of interest. According to Wells (*Biomedical Ultrasonics*, as cited above), the transmission speed varies up to plus or minus 10% within the soft tissues. When the aperture is kept small, the intervening tissue is assumed to be homogeneous, and any variation is consequently ignored. When the size of the aperture is increased to improve the lateral resolution, the additional elements of a phased array may be out of phase and may actually degrade the image rather than improve it.

[0006] In the case of abdominal imaging, it has also been recognized that increasing the aperture size could improve the lateral resolution. Although avoiding the ribs is not a problem, beam forming using a sparsely filled array and, particularly, tissue speed variation needs to be compensated. With single aperture ultrasound probes, it has been commonly assumed that the beam paths used by the elements of the transducer array are close enough together to be considered similar in tissue density profile, and therefore that no compensation was necessary. The use of this assumption, however, severely limits the size of the aperture that can be used.

[0007] The problems of limited total aperture size have been addressed by the development of multiple aperture ultrasound imaging techniques as shown and described for example in US Patent 8,007,439, and US Patent Application Publication 2011/0201933.

[0008] US 5,797,845 discloses an ultrasound apparatus for three dimensional image reconstruction. The apparatus comprises one or more transmit arrays and one or more receive arrays that are separated from one another.

[0009] US 2005/124883 discloses an ultrasound imaging device comprising a transducer array for (i) emitting acoustic pulses over a plurality of transmit channels and (ii) receiving echoes of those pulses over a plurality of receive channels.

SUMMARY OF THE DISCLOSURE

[0010] The present invention provides an ultrasound imaging system according to claim 1 and an ultrasound imaging method according to claim 9.

[0011] Although the term "embodiment" is frequently used in the brief description of the figures and in the detailed description it is understood that only those embodiments which fall under the scope of the appended claims are embodiments of the invention.

BRIEF DESCRIPTION OF THE FIGURES

[0012]

FIG. 1 is an illustration of an ultrasound system control panel with aperture view angle and aperture width controls.

FIG. 2 is a schematic diagram of a concave curvilinear transducer array where various elements are designated as transmit and receive apertures.

FIG. 2A is a schematic diagram of a concave curvilinear transducer array where elements are put to use in the reciprocal transmit or receive function relative to FIG. 2.

FIG. 2B is a schematic diagram of an embodiment of a concave curvilinear transducer array where elements of transmit and receive apertures are pre-designated to insonify each other in rapid succession using like sized apertures.

FIG. 2C is a schematic diagram of an embodiment of a concave curvilinear transducer array demonstrating how transmit and receive apertures can be widened around a desired view angle to achieve greater resolution of the target area.

FIG. 3 is a schematic diagram of an embodiment of a concave curvilinear transducer array illustrating a pulse transmitted by a single designated transmit aperture and being received by multiple designated receive apertures.

FIG. 3A is a schematic diagram of an embodiment of a concave curvilinear transducer array where the transmit aperture and multiple receive apertures can be electronically controlled to operate in different positions.

FIG. 4 is a schematic diagram of an embodiment a concave curvilinear matrix with curvature in two orthogonal directions, also referred to as a Three Dimensional (3D) array. Each element in a 3D array is displaced relative to adjacent elements in all of x, y, and z axes. In this illustration, an element or elements of a transmit aperture is designated to insonify the medium. Multiple targets in the medium are illustrated for the purpose of demonstrating how volumetric data may be gathered. Multiple receive apertures are illustrated to demonstrated how simultaneous gathering of data may involve timing and tissue speed of sound adjustments.

FIG. 4A schematically illustrates an embodiment of a 3D array. Multiple transmit apertures T_1 through T_N are indicated for the purpose of demonstrating transmit pulses being received on one or more receive apertures R_2 and/or R_3 . A single target is indicated for the purpose of demonstrating how data may be gathered.

FIG. 4B schematically illustrates an embodiment of a 3D array being used to collect data for a 2D longitudinal slice along the x axis. In this instance, a line of elements in the transverse axis z are being used to form transmit aperture T_1 . Data along the longitudinal slice may be collected by elements located in receive aperture R_2 . Multiple transmit apertures, identified as T_1 through T_5 that can be used along the length of the longitudinal slice to assist in data collection over time. Another receive aperture R_3 is indicated that can be used to collect either simulta-

neous data for the same transverse slice, or separate data for a different longitudinal slice.

FIG. 4C schematically illustrates an embodiment of a 3D array being used to collect data for a 2D transverse slice along the z axis. In this instance, a line of elements in the longitudinal axis x are being used to form transmit aperture T_1 . Data along the transverse slice may be collected by elements located in receive aperture R_2 . Multiple transmit apertures T_1 through T_5 are indicated that can be used along the length of the longitudinal slice to assist in data collection over time. Another receive aperture R_3 is indicated that can be used to collect either simultaneous data for the same transverse slice, or separate data for a different transverse slice.

FIG. 4D illustrates a data volume with a 2D longitudinal slice of data highlighted within the volume. This illustrates a capability of multiple aperture imaging to interchange volumetric 3D/4D imaging with higher resolution 2D imaging in near real time to allow for simultaneous presentation on a display.

FIG. 4E illustrates a data volume with a 2D transverse slice of data highlighted within the volume. This illustrates a capability of multiple aperture imaging to interchange volumetric 3D/4D imaging with higher resolution 2D imaging in near real time to allow for simultaneous presentation on a display.

FIG. 5 is a schematic view showing a concave curvilinear probe over a medium of tissue with a relatively large radius curvature (e.g. abdomen, pelvis, etc.).

FIG. 5A is a bottom view of an embodiment of a curvilinear array (e.g., 1D, 1.5D or 2D) in a probe such as that shown in FIG. 5.

FIG. 5B is a bottom view of an embodiment of a matrix array (e.g., 2D or 3D) in a probe such as that shown in FIG. 5.

FIG. 5C is a bottom view of an embodiment of a CMUT array in a probe such as that shown in FIG. 5.

FIG. 6 is a schematic view showing an embodiment of a concave curvilinear probe over a medium of tissue with relatively small radius curvature (e.g. arm, leg, neck, wrist, ankle, etc.).

FIG. 6A is a schematic view of an embodiment of a concave curvilinear array similar to that of FIG. 6, but in a probe housing with flex connections that allow for cable connections to be made on the side of the probe housing.

FIG. 6B is a bottom view of an embodiment of a curvilinear array (e.g., 1D, 1.5D or 2D) in a probe such as those shown in FIGS. 6 and 6A.

FIG. 6C is a bottom view of an embodiment of a curved matrix (e.g., 2D or 3D) array in a probe such as those shown in FIGS. 6 and 6A.

FIG. 6D is a bottom view of an embodiment of a CMUT array in a probe such as those shown in FIGS. 6 and 6A.

FIG. 7 is a plan view of a concave transducer housing

of an embodiment of the probe of FIG. 6A with an adjustable handle aligned with the longitudinal axis of the array.

FIG. 7A is a plan view of a concave transducer housing of an embodiment of the probe of FIG. 6A with an adjustable handle aligned with the transverse axis of the array.

FIG. 7B is a side schematic view showing a concave curvilinear probe of FIG. 7A over a medium of tissue with a relatively large-radius curvature (e.g. abdomen, pelvis, etc.).

FIG. 7C is a bottom view of a curvilinear array (e.g., 1D, 1.5D or 2D) available for use with the probe styles illustrated in FIGS. 7A - 7B.

FIG. 7D is a bottom view of a matrix array (e.g., 2D or 3D) available for use with the probe styles illustrated in FIGS. 7A - 7B.

FIG. 7E is a bottom view of a CMUT array available for use with the probe style illustrated in FIGS. 7A - 7B.

FIG. 7F is a bottom view of a concave curved transducer array (e.g., 3D or CMUT) arranged in an elliptical pattern, as used in a probe such as that shown in FIGS. 7A - 7B.

FIG. 7G is a plan view of a concave array probe housing identifying the section line for FIG. 7H.

FIG. 7H is a sectional view of the concave array probe housing of FIG. 7G taken along line A-B. This embodiment illustrates flex connectors and cabling connections on the right side or bottom of the probe. A calibration chip, synchronization module, probe position displacement sensor are also shown in the probe handle.

FIG. 8 is a diagram showing an embodiment of an adjustable ultrasound probe. This version of an adjustable probe has five arrays, each having an associated flex connector. A calibration chip, synchronization module, probe position displacement sensor are also shown in the probe handle.

FIG. 8A is a diagram showing the five arrays of the probe of FIG. 8 deployed in a custom contoured arrangement to match the desired physiology.

FIG. 8B is a side view of two of the arrays of the probe of FIG. 8, showing details of an embodiment of adjustable hinges between the arrays and a tension cable. The adjustable hinges are shown connected to the backing block of each array.

FIG. 8C is a bottom view illustrating an embodiment of the individual arrays (e.g., 1D or 1.5D) in a probe such as that shown in FIG. 8.

FIG. 8D is a bottom view illustrating an embodiment of the individual arrays as matrix arrays (e.g., 2D) in a probe such as that shown in FIG. 8.

FIG. 8E is a bottom view illustrating an embodiment of the individual arrays as CMUT arrays in a probe such as that shown in FIG. 8.

DETAILED DESCRIPTION

[0013] Some embodiments herein provide systems and methods for designing, building and using ultrasound probes having continuous arrays of ultrasound transducers which may have a substantially continuous concave curved shape in two or three dimensions (i.e. concave relative to an object to be imaged). Other embodiments herein provide systems and methods for designing, building and using ultrasound imaging probes having other unique configurations, such as adjustable probes and probes with variable configurations.

[0014] The use of calibrated multiple aperture array or arrays combined with multiple aperture imaging methods allow for custom shaped, concave or even adjustable probes to be utilized in ultrasound imaging. Further, uniquely shaped ultrasound probe solutions are desirable in order to overcome the various shortcomings in the conventional rectangular linear, matrix or capacitive micromachined ultrasonic transducer or "CMUT" arrays in order to maintain information from an extended phased array "in phase", and to achieve a desired level of imaging lateral resolution.

[0015] In some embodiments, the ultrasound imaging system may be configured to allow for manual or automatic control of view angle, beam width and aperture size. This feature can be very advantageous when attempting to image tissue obscured by gas, bone or other ultrasound-opaque structures (e.g. vertebrae, joints, peripheral vasculature, organs located inside the thoracic cavity, etc.). With a shaped probe placed over the region of interest, the sonographer may control view angle of the target. Once the desired view angle is selected, the sonographer may electronically control aperture width in order to achieve the best resolution at the desired depth.

[0016] In one embodiment, there is a medical ultrasound apparatus having: (a) electronics configured for pulsing piezoelectric elements to transmit ultrasonic waves into human (or animal) tissue; (b) electronics configured to receive the resulting echo signals; (c) electronics configured to process the echo signals to form images; and (d) a probe having a plurality of receive elements within a receive subaperture, where the receive subaperture is sufficiently small that speed of sound variations in the paths from scatterers to each of the receive elements are sufficiently small to avoid phase cancellation when coherent averaging is used based on the assumption of uniform speed of sound profile over all paths. In addition, the probe may have a transmit element or plurality of transmit elements within a transmit subaperture, with at least one of the transmit elements being separated from the receive subaperture(s).

[0017] In another embodiment, the separation of transmit elements from elements of a receive subaperture is imposed for the purpose of increasing the total aperture width which determines the lateral resolution of the system without making the receive subaperture so large that phase cancellation degrades the image.

[0018] In another embodiment, the transmit subaperture may be sufficiently small that speed of sound variations in the paths from the transmit elements to scatterers are sufficiently small that the differences between the actual transmit times along these paths and the theoretical times assuming a constant nominal speed of sound vary from each other by a substantially small amount. In some embodiments, an acceptable variation in actual vs. theoretical travel times is less than one period of the ultrasound pulse. In some embodiments, the imaging control electronics insonifies the tissue to be imaged with a single ping, and beamforming and image processing electronics may form images by coherent addition of images formed by each single ping. In other embodiments, the beamforming and image processing electronics may form images by incoherent addition of images formed by each single ping.

[0019] Imaging transmit control electronics, beamforming electronics and image processing electronics may be collectively referred to herein as multiple aperture ultrasound imaging (or MAUI) electronics.

[0020] In still another embodiment, the MAUI electronics may form images by using image alignment such as cross correlation to align images and then adding the images incoherently.

[0021] In still another embodiment, the transmit aperture is not necessarily small and may include a receive subaperture. The MAUI electronics may insonify the tissue to be imaged with a single ping and may form images by incoherent addition of complete images formed by each single ping. Still further, the MAUI electronics may be configured to form images by using cross correlation to align images and then adding the images incoherently. In another embodiment, the system controller may include the processing capability where images formed with the different groups can be averaged together to form images with reduced noise and artifacts.

[0022] The improvements described herein are applicable to a wide variety of probe types including, for example, a general radiology concaved multiple aperture probe, a bracelet multiple aperture probe, a palm multiple aperture probe, and an adjustable multiple aperture probe.

[0023] In other alternative embodiments, aspects of the present provide for using unfocused pings for transmit, the transmit aperture can be much wider than the receive aperture and can enclose it.

[0024] In additional embodiments, receive elements of only one aperture can be used to construct an image when a transmit pulse or wave comes from an element or array of elements located outside and away from the receive elements' aperture, without using speed of sound correction in order to achieve a coherently averaged image.

[0025] Although several embodiments herein are described with reference to medical ultrasound imaging, the skilled artisan will recognize that features and advantages of the embodiments herein may also be achieved

in non-medical ultrasound imaging applications, or in non-imaging applications of ultrasound.

[0026] As used herein the terms "ultrasound transducer" and "transducer" may carry their ordinary meanings as understood by those skilled in the art of ultrasound imaging technologies, and may refer without limitation to any single component capable of converting an electrical signal into an ultrasonic signal and/or vice versa. For example, in some embodiments, an ultrasound transducer may comprise a piezoelectric device. In other embodiments, ultrasound transducers may comprise capacitive micromachined ultrasound transducers (CMUT).

[0027] Transducers are often configured in arrays of multiple individual transducer elements. As used herein, the terms "transducer array" or "array" generally refers to a collection of transducer elements mounted to a common backing plate. Such arrays may have one dimension (1D), two dimensions (2D), 1.5 dimensions (1.5D) or three dimensions (3D). Other dimensioned arrays as understood by those skilled in the art may also be used. Transducer arrays may also be CMUT arrays. An element of a transducer array may be the smallest discretely functional component of an array. For example, in the case of an array of piezoelectric transducer elements, each element may be a single piezoelectric crystal or a single machined section of a piezoelectric crystal.

[0028] A 2D array can be understood to refer to a substantially planar structure comprising a grid of ultrasound transducer elements. Such a 2D array may include a plurality of individual elements (which may be square, rectangular or any other shape) arranged in rows and columns along the surface of the array. Often, a 2D array is formed by cutting element sections into a piezoelectric crystal.

[0029] As used herein, references to curved 1D, 1.5D or 2D transducer arrays are intended to describe ultrasound transducer arrays with curved surfaces having a curvature about only one axis (e.g., a transverse axis of a rectangular array). Thus, embodiments of 1D, 1.5D or 2D curved arrays may be described as partial cylindrical sections.

[0030] As used herein, the term "3D array" or "3D curved array" may be understood to describe any ultrasound transducer array with a curved surface having curvature about two or more axes (e.g., both transverse and longitudinal axes of a rectangular array). Elements of a 3D curved array may be displaced relative to all adjacent elements in three dimensions. Thus, 3D curved arrays may be described as having a 3-dimensional quadric surface shape, such as a paraboloid or a section of a spherical surface. In some cases, the term 3D array may refer to curved CMUT arrays in addition to machined piezoelectric arrays.

[0031] As used herein, the terms "transmit element" and "receive element" may carry their ordinary meanings as understood by those skilled in the art of ultrasound imaging technologies. The term "transmit element" may refer without limitation to an ultrasound transducer ele-

ment which at least momentarily performs a transmit function in which an electrical signal is converted into an ultrasound signal. Similarly, the term "receive element" may refer without limitation to an ultrasound transducer element which at least momentarily performs a receive function in which an ultrasound signal impinging on the element is converted into an electrical signal. Transmission of ultrasound into a medium may also be referred to herein as "insonifying." An object or structure which reflects ultrasound waves may be referred to as a "reflector" or a "scatterer."

[0032] As used herein, the term "aperture" may refer to a conceptual "opening" through which ultrasound signals may be sent and/or received. In actual practice, an aperture is simply a group of transducer elements that are collectively managed as a common group by imaging control electronics. For example, in some embodiments an aperture may be a physical grouping of elements which may be physically separated from elements of an adjacent aperture. However, adjacent apertures need not necessarily be physically separated.

[0033] It should be noted that the terms "receive aperture," "insonifying aperture," and/or "transmit aperture" are used herein to mean an individual element, a group of elements within an array, or even entire arrays with in a common housing, that perform the desired transmit or receive function from a desired physical viewpoint or aperture. In some embodiments, such transmit and receive apertures may be created as physically separate components with dedicated functionality. In other embodiments, any number of send and/or receive apertures may be dynamically defined electronically as needed. In other embodiments, a multiple aperture ultrasound imaging system may use a combination of dedicated-function and dynamic-function apertures.

[0034] As used herein, the term "total aperture" refers to the total cumulative size of all imaging apertures. In other words, the term "total aperture" may refer to one or more dimensions defined by a maximum distance between the furthest-most transducer elements of any combination of send and/or receive elements used for a particular imaging cycle. Thus, the total aperture is made up of any number of sub-apertures designated as send or receive apertures for a particular cycle. In the case of a single-aperture imaging arrangement, the total aperture, subaperture, transmit aperture, and receive aperture will all have the same dimensions. In the case of a multiple aperture imaging arrangement, the dimensions of the total aperture includes the sum of the dimensions of all send and receive apertures.

[0035] In some embodiments, two apertures may be located adjacent one another on a continuous array. In still other embodiments, two apertures may overlap one another on a continuous array, such that at least one element functions as part of two separate apertures. The location, function, number of elements and physical size of an aperture may be defined dynamically in any manner needed for a particular application. Constraints on these

parameters for a particular application will be discussed below and/or will be clear to the skilled artisan.

[0036] Multiple aperture ultrasound imaging techniques can benefit substantially from the physical and logical separation of ultrasound transmitting and receiving functions. In some embodiments, such systems may also substantially benefit from the ability to receive echoes substantially simultaneously at two or more separate receive apertures which may be physically spaced from a transmit aperture. Further benefits may be achieved by using one or more receive apertures located on a different scan plane than elements of a transmit aperture.

[0037] Elements and arrays described herein may also be multi-function. That is, the designation of transducer elements or arrays as transmitters in one instance does not preclude their immediate redesignation as receivers in the next instance. Moreover, embodiments of the control system herein include the capabilities for making such designations electronically based on user inputs, pre-set scan or resolution criteria, or other automatically determined criteria.

[0038] In some embodiments, each echo detected at a receive aperture may be stored separately in volatile or non-volatile memory within the imaging electronics. If the echoes detected at a receive aperture are stored separately for each pulse from the insonifying aperture, an entire two-dimensional image can be formed from the information received by as few as just one element. Additional copies of the image can be formed by additional receive apertures collecting data from the same set of insonifying pulses. Ultimately, multiple images can be created substantially simultaneously from one or more apertures and combined to achieve a comprehensive 2D or 3D image.

[0039] Multiple Aperture Ultrasound Imaging (MAUI) methods and systems have been previously introduced in Applicants' prior US patent applications referenced above. These applications describe multiple aperture imaging techniques and systems including embodiments which consider each individual receive element as an independent aperture from which a complete 2D image can be formed. Many such receive apertures can form many reconstructions of the same 2D image but with different point spread functions and different noise components. A combination of these images provides a vastly-improved overall image in terms of both lateral resolution and reduction of speckle noise.

[0040] As discussed in Applicant's previous applications, in order for the images from multiple receive apertures to be combined coherently, the relative acoustic position of each element relative to the transmit element(s) (or some other fixed coordinate system relative to the probe) must be known precisely to a desired degree of accuracy. Traditionally, the position of transducer elements is typically assumed to correspond to a geometric center of a structure forming an element. For example, in the case of a conventional 1D phased array probe, the mechanical position of the elements may determined by

the size of the cuts inside the crystal wafer 110, in FIG. 6B. The acoustic center is generally assumed to be at the center of the shaped crystalline structure; (e.g., a parabolic channel running down the mid portion of the elements, 120, FIG. 6B).

[0041] However, the acoustic position of transducer elements may not necessarily correspond exactly to their geometric or mechanical positions. Therefore, in some embodiments, the true acoustic position of each element in an array can be determined by a calibration system and process, as described in Applicants' previous applications.

[0042] Substantial imaging and practical use benefits may be achieved by using multiple aperture imaging processes with a concave curved ultrasound transducer array. In some embodiments, a concave transducer array may have a relatively large radius of curvature, as shown for example in FIG. 6. In other embodiments, as shown for example in FIG. 7 a concave transducer array may have a relatively small radius of curvature. In some embodiments, such a concave curvature may be substantially continuous as shown, or a similar concave structure may be formed by joining a plurality of linear segments. With adequate calibration, virtually any array shape may be formed and utilized.

[0043] Although the following embodiments are described with reference to a single, continuous transducer array, the skilled artisan will recognize that the same basic structures, features and benefits may be achieved by using a plurality of separate transducer arrays, each of which may have a planar or curved shape as desired. Thus, it is to be appreciated that any number of elements or blocks of arrays may be used in a multiple aperture probe using the systems and methods described herein.

[0044] As will be discussed in more detail below, in some embodiments, a concave ultrasound imaging probe may be used in combination with imaging control electronics having a number of unique adjustment and control parameters. For example, by providing a substantially continuous concave curved transducer array in combination with suitable control electronics, the physical location of transmit and/or receive apertures may be changed dynamically without moving the probe. Additionally, the size and number of elements assigned to a transmit and/or receive aperture may be changed dynamically. Such adjustments may allow an operator to adapt a system for a broad range of variations in use and patient physiology.

[0045] FIG. 1 illustrates an embodiment of a multiple aperture ultrasound imaging system control panel configured for use with at least one ultrasound imaging array and a control system configured to drive and control ultrasound imaging with the array(s). The control system can be referred herein to as MAUI electronics, and can include such features as a computer processor, memory, a pulse generator, software configured to control any attached ultrasound arrays. The MAUI electronics are illustrated throughout this application, and it should be un-

derstood that the various embodiments of ultrasound arrays illustrated herein can each be driven and controlled by MAUI electronics. In some embodiments, a MAUI control panel may include aperture controls such as an aperture view angle control 410 and an aperture width control 420. A MAUI control panel may also include element controls 430 and 440 configured to adjust the number of elements used for each transmit aperture and each receive aperture, respectively. In some embodiments, the controls 410, 420, 430, 440 may include buttons, knobs, scroll wheels, trackballs, touch pads, sliders or any other suitable human interface device.

[0046] FIG. 2 illustrates one embodiment of a concave curvilinear array of ultrasound transducer elements during a single multiple aperture ultrasound imaging cycle. In this illustration, one or more elements in a transmit aperture T_1 are shown transmitting energy into a medium. Transmit beamforming may utilize either a phased array or be a simple ping. In either case, energy is transmitted toward region of interest which has at least one reflector 170. Receive aperture elements R_1 may be electronically designated to collect data for this transmit cycle by the MAUI Electronics 140.

[0047] Based on calibrated acoustic position data defining the position of each element, individual distances of all receive elements in R_1 from the element(s) of the transmit aperture T_1 for this capture period may be computed in firmware or hardware. This allows data from the receive aperture R_1 to be assembled into an aligned image in real time immediately upon receipt. Image compounding or post processing is not required and may be omitted.

[0048] The size (e.g. width) of the single aperture of a conventional phased array probe, and hence the resolution, can be severely limited by the variation of speed of sound in the tissue between the transducer and the organ of interest. Although speed of sound in various soft tissues throughout the body can vary by +/-10%, it is usually assumed that the speed of sound is constant in the path between the transducer and the organ of interest. This assumption is valid for narrow transducer arrays in systems using one transducer array (e.g., a single array used for both transmit and receive). However, the constant speed of sound assumption breaks down as the probe's total aperture becomes wider because the ultrasound pulses pass through more tissue and possibly diverse types of tissue. Tissue diversity under the length of the transducer array may affect both the transmit and the receive functions.

[0049] When a reflector such as reflector 170 in FIG. 2 is insonified by either a focused pulse from a group of transmit elements or a ping from a single transmit element, the reflector 170 reflects an echo back to all of the elements of a designated receive aperture R_1 . Coherent addition of images collected by elements in this receive aperture can be effective if the speed of sound variations in the paths from reflector 170 to each of the receiver elements in R_1 do not exceed +/-180 degrees phase shift

relative to one path chosen as reference.

[0050] The maximum physical size of the aperture R_1 for which coherent addition can be effective is dependent on tissue variation within the patient and cannot be computed accurately in advance. Conventional ultrasound imaging systems are typically designed with an aperture width that is a compromise for a wide range of possible patients, studies and view angles so as to avoid phase conflicts for a wide range of expected uses. However, because they involve compromise, such conventional probes do not necessarily produce an optimum image. Phase coherence is equally important when using a group of elements to generate a focused transmit beam, and again is often a compromise in conventional transducer array widths and operation.

[0051] Thus, in some embodiments, the size (e.g., width in terms of number of designated elements) of transmit and/or receive apertures may be controlled either automatically or manually using controls such as the multiple aperture ultrasound imaging system control panel shown in FIG. 1. Adjusting the aperture size may allow the operator to find the best aperture for each individual patient. In alternative embodiments, an optimum aperture size may be found automatically by programming the control electronics to rapidly try several array sizes and pick the one yielding best image acuity (e.g. sharpness, high frequency content). Thus, in some embodiments, a control panel may include button or other control to initiate such an automatic aperture-size-determination procedure. In some embodiments, such aperture size adjustments may be applied to a total aperture size for a probe or application. Alternatively or in addition, such aperture size adjustments may be applied to individual transmit or receive apertures.

[0052] An optimum receive aperture size for a particular patient or application may be determined electronically or controlled manually. The optimum aperture is the aperture size that retains the best signal to noise ratio while still in phase. An aperture that is too wide will lose one or both of these qualities, and degrade the image. Therefore in some embodiments, the sonographer may control the size of the group of receiver elements used for each receiver group R_1 in FIG. 2 by manipulating controls 410, 420, 430 and 440 until he/she sees no further improvement in image quality. In another embodiment, a controller in the MAUI electronics 140 can be configured to automatically select the size of the group of receiver elements used for receiver group R_1 by determining the best signal to noise ratio while still in phase.

[0053] The size of the group of transmitter elements T_1 depends on whether the transmitted pulse is a focused beam formed from the phased firing of a group of transducer elements or an unfocused pulse from just one or a few elements at a time. In the first case, the transmit aperture size may be limited to the same size as the optimum receive aperture size. In embodiments using unfocused pings, the transmit aperture size is much less critical since variation in the path time from transmitter

elements to a reflector such as 170 will change only the displayed position of the point corresponding to the reflector 170. For example, a variation resulting in a phase shift of 180 degrees in the receive paths results in complete phase cancellation, whereas the same variation on the transmit paths results in a displayed position error of only a half wavelength (typically 0.2 mm), a distortion that would typically not be noticed.

[0054] Thus, with continued reference to FIG. 2, the speed of sound along the paths from element(s) of the transmit aperture T_1 to the reflector 170 need not be accounted for in the coherent addition of the received signals. The aperture size of the receiver group R_1 , on the other hand, may be as large as for a conventional phased array (e.g. about 2cm) in some embodiments. But unlike a conventional array, the total aperture 190 (e.g. the maximum distance from the furthest-left transmit element of T_1 to the furthest-right receive element of R_1 in the FIG. 2 embodiment) determining the lateral resolution of the system is much larger.

[0055] A single image can be formed by coherent averaging of all of the signals arriving at the receiver elements as a result of a single insonifying ping. Summation of these images resulting from multiple pings may be accomplished either by coherent addition, incoherent addition, or a combination of coherent addition by groups and incoherent addition of the images from the groups. Coherent addition (retaining the phase information before addition) maximizes resolution whereas Incoherent addition (using the magnitude of the signals and not the phase) minimizes the effects of registration errors and averages out speckle noise. Some combination of the two modes is probably best. Coherent addition can be used to average ping images resulting from transmit elements that are close together and therefore producing pulses transmitted through very similar tissue layers. Incoherent addition can then be used where phase cancellation would be a problem. In the extreme case of transmission time variation due to speed of sound variations, 2D image correlation can be used to align ping images prior to addition.

[0056] The wide aperture achieved by separating the transmit and receive apertures is what allows for the higher resolution imaging associated with Multiple Aperture Ultrasound Imaging (MAUI). However, this wide aperture does not by itself reduce another significant detractor of ultrasound imaging; speckle noise.

[0057] Speckle noise patterns are associated with the transmit source. That is, during receive beamforming, the speckle noise pattern from a steady state phased array or ping transmit source appear as constant "snow" in the displayed image as long as the probe or tissue being imaged is not turned or moved significantly during imaging. If the probe is moved or twisted, the speckle noise or "snow" on the image will obscure a new portion of the image. Hence, data collected at a single receive aperture from transmissions from alternate transmit apertures will subsequently have many different speckle

noise patterns.

[0058] In the embodiment illustrated in FIG. 2 data collected at receive aperture R_1 is coming from a single transmit source T_1 , and therefore will have a singular consistent speckle noise pattern. By itself, this is the same limiting factor of conventional ultrasound today. However, by initiating a second insonification from the reciprocal positions T_{1R} and R_{1R} of FIG. 2A upon the completion of the first image capture, a second image may be obtained almost immediately. This second image (from transmit source T_{1R}) will have a different speckle noise pattern than the first (from transmit source T_1). Thus, by combining the two images, both speckle noise patterns may be substantially identified and eliminated. The ability to invert the roles of transmitter and receiver in array elements produces differing noise patterns which will substantially cancel each other out once combined. The result of this array role reversal is a much clearer ultrasound image while still maintaining the same high resolution from the wider total aperture 190.

[0059] FIG. 2B demonstrates an embodiment in which a concave curved multiple aperture array cycles through a number of different views of the region of interest 170. The advantage of this process is to gain sequential images of the same target and then combine the images for a more comprehensive presentation to the sonographer. In this case, the MAUI Electronics 140 may simply cycle through a programmable sequence of transmit and receive apertures across the entire width of the array or collective arrays while maintaining a fixed maximum total aperture width.

[0060] In some embodiments, an array of this type may be configured to include transmit and receive elements with different frequency ranges interspersed in the array. As an example, T_1 and R_1 could be tuned to 2 MHz, T_2 and R_2 could be tuned to 5 MHz, and T_3 and R_3 could be tuned to 10 MHz. This technique would further reduce speckle noise in the images.

[0061] FIG. 2B also demonstrates another unique feature of some embodiments of multiple aperture arrays called view angle control. The view angle may be defined as the angle α between lines 180 and 190 that could be drawn from T_1 to 170 and from R_1 to 170. In some embodiments, the MAUI electronics 140 may be configured to automatically move the transmit T_1 and receive R_1 apertures along the array or arrays without changing the total distance between the transmit T_1 and receive R_1 apertures. In other embodiments, the transmit and receive apertures can be moved manually, such as with the view angle control 410 of FIG. 1.

[0062] In some embodiments, further improvements of the images can sometimes be obtained by rapidly changing the positions of the groups (including switching the designations of the groups relative to transmit and receive functions) and adding the resulting images incoherently.

[0063] An array placed near a physiology that creates an obstruction (e.g. a vertebrae, rib, wrist bone, etc.)

would not be able to combine or compound a complete image. With a conventional probe, a sonographer would physically move the probe on the patient's skin to obtain a clear ultrasound window. However, with a dynamic multiple aperture ultrasound probe, the view angle of the probe can be adjusted to compensate for an obstruction in the field of view. For example, if the view created by T_2 and R_2 is obstructed by a bone or other obstruction 150, then the MAUI electronics 140 can automatically rotate that view angle over to T_1 and R_1 , or alternatively to T_3 and R_3 , until the region of interest is un-obscured. In other embodiments, this technique can be performed manually by a sonographer.

[0064] FIG. 2C illustrates another important capability of some embodiments of multiple aperture arrays, referred to herein as total aperture size control. In this embodiment, the view angle created by T_{1A} and R_{1A} provides an obstruction-free view of the region of interest including reflector 170 which avoids obstruction 150. In this example, the system is providing multiple aperture imaging with a total aperture width of A_{1A} . Using total aperture size control, the total aperture width can be varied either inward or outward on the array, while maintaining a fixed view angle center. Thus, in some embodiments, as a total aperture size is adjusted, both transmit and receive apertures may be electronically moved at the same rate outward or inward from the fixed view angle center so as to maintain the original view angle.

[0065] Radian resolution is proportional to λ/d , where λ is wavelength and d is total aperture width. The wider the total aperture, the higher the resolution; the smaller the total aperture, the lower the resolution. The total aperture width can be varied to get the best possible resolution for a chosen view angle. For example, in the embodiment of FIG. 2C, the total aperture width can be maximized by selecting the total aperture width between T_{1B} and R_{1B} , resulting in a total aperture width of A_{1B} .

[0066] In additional embodiments, data may be collected at multiple receive apertures for a single transmit pulse, as illustrated in FIGS. 3 and 3A. Data collection in this fashion provides the added benefit of increased aperture width A_1 during real time data collection.

[0067] In FIG. 3, total aperture width A_1 is determined by the distance between the outer most elements of receive apertures R_1 and R_2 . In FIG. 3A, the total aperture width A_1 is determined by the distance between the outer most elements of transmit aperture T_1 and receive aperture R_2 . Since multiple apertures are being used in the receive beamformer simultaneously, higher resolution can be attained in real time. This capability allows for precise data capture on moving objects, like coronary valves.

[0068] However, unlike embodiments using only a single receive aperture, multiple receive aperture beamforming often requires a speed of sound correction to accommodate differing tissue attenuation speeds situated along multiple "lines of sight" to the region of interest (e.g., referring to FIGS. 3 and 3A, a first line of sight being

from reflector 170 to R_1 , and a second line of sight being from reflector 170 to R_2). This calculation should be made if data collected nearly simultaneously from different receive apertures is to be coherently combined. Embodiments of techniques and methods for such speed of sound corrections are described in Applicants' prior patent applications referenced above.

[0069] The examples in FIGS. 2 - 3A demonstrate embodiments of multiple aperture imaging using a multiple aperture array or arrays with elements that are aligned within the same scan plan. Such arrays may be 1D, 1.5D, or 2D or CMUT concave curved arrays. 3D volumes can be constructed by piecing together 2D slices generated using such systems into a 3D volume. This is a post processing function, so data from a 1D multiple aperture array cannot image 3D data in real time (also known as 4D imaging).

[0070] Embodiments of concave curved arrays of 1.5D, 2D, 3D and CMUT transducer arrays have more capabilities which will now be examined. Such arrays may have concave curvature about one or two or more axes. Although many of the following embodiments are described with reference to arrays having curvature about two axes, similar methods may be applied using transducer arrays having curvature about only one axis.

[0071] FIG. 4 illustrates a concave 3D transducer array 300 having curvature about two orthogonal axes. In some embodiments, a 3D concave curved array 300 may be constructed using machined piezoelectric transducers. In other embodiments, the array 300 may be constructed using CMUT transducers such as those illustrated in FIGS. 6C, 7E or 8E. Calibration of a 3D array may be needed as each element of the array will have slightly different positions in the x axis 301, y axis 302 and z axis 303.

[0072] In some embodiments, calibration data including element position information may be stored in a calibration chip onboard each MAUI probe so that it can be used by MAUI electronics during processing. In other embodiments, calibration data including element position information may be stored in a remote database which may be accessed electronically by communications components within the probe or within an ultrasound imaging system. For example, calibration data may be stored in an Internet-accessible database which may be accessed by an ultrasound imaging system. In such embodiments, the probe may include a chip storing a unique identifier which may be associated with corresponding calibration data in a remote database.

[0073] In the illustration of FIG. 4, a snap shot of multiple aperture data collection is depicted en route to building an image of an entire volume 310. Here, an element or elements of a transmit aperture T_1 transmit a pulse into the volume that includes scatterers such as 321 and 322. The elements making up receive aperture R_2 may be assembled in a variety of shapes. Here, a square of elements makes up the receive apertures R_2 and R_3 . As mentioned above, the speed of sound along the path

from the transmit aperture T_1 to the reflector 321 or 322 is irrelevant to the coherent addition of the received signals as long as a single aperture is used to receive, however, speed of sound corrections can be made to improve image quality when using multiple receive apertures R_1 and R_2 .

[0074] In some embodiments, the size of the receive aperture R_2 may be as large as for a conventional phased array (e.g., about 2cm). But unlike a conventional array, the total aperture 340 determining the lateral and transverse resolution of the system is much larger comprising the distance from the transmitter T_1 to the group of receiver elements R_2 , and could be as wide as the entire array 300 or wider if a transmitter was located on another array within the probe (or in a separate probe in electronic communication). The elements located in the receive aperture R_2 each collect volumetric data from the T_1 transmit pulse. Since a speed of sound correction is not required for data collected from a single transmit pulse at a single aperture, data from each element of R_2 may be coherently averaged with the other elements in pre-processing.

[0075] A speed of sound correction may or may not be required for averaging volume renderings for multiple pulses depending on the size of the transmit aperture (i.e. a total distance between furthest elements of a transmit aperture). If the transmit aperture is small enough that the transmit elements transmit through substantially the same types of tissue, coherent addition may still be possible. If the transmit aperture is larger, a speed of sound correction in the form of incoherent addition may be required.

[0076] If the transmit aperture is large enough that the transmit elements are still farther apart, the correction may take the form of incoherent addition of echoes received at each element, but alignment may be accomplished by cross correlation or some form of adjustment to maximize acuity, such as adjustment of the view angle, individual aperture size and/or total aperture size. A 3D concave array may provide mechanically better view angles of a region of interest than conventional coplanar 2D arrays because of its concave curvature and width.

[0077] In some embodiments, a 3D array may also image tissues of varying density. FIG. 4 illustrates a second receive R_3 aperture that can be used simultaneously with R_2 during a single transmit pulse from a transmit aperture T_1 . However, unlike the single receive aperture situation, multiple receive aperture beamforming may require a speed of sound correction to accommodate differing tissue attenuation speeds situated along multiple "lines of sight" to the region of interest.

[0078] In this case, the elements located in aperture R_3 may collect volumetric data from the T_1 transmit pulse. Again, since a speed of sound correction is not required for echoes received by multiple elements of the single receive aperture R_3 , data from each element in R_3 may be coherently averaged with the other elements of R_3 in pre-processing.

[0079] Volumes for R_2 and R_3 may be stored in memory and may then be incoherently averaged with one another to create a single 3D volume. While only receive apertures R_2 and R_3 are illustrated here, any number of receive apertures can be used. In some embodiments, receive apertures may use the entire array 300 as a total aperture. Using multiple receive apertures greatly reduces noise as well as increases total aperture size to provide higher resolution.

[0080] Like 2D multiple aperture imaging, the 3D multiple aperture imaging made possible by a 3D concave curved array may use many transmit apertures. Even with a 3D array, the noise patterns associated with T_1 will have a singular consistent speckle noise pattern. FIG. 4A demonstrates transmit pulses from multiple apertures T_1 through T_N . In the illustrated case, alternate transmit locations may be utilized, but only a single receive aperture R_2 is used so speed of sound corrections are not needed. Data collected at R_2 can be coherently averaged for each element in that receive aperture and subsequently for each transmit pulse, and finally placed into memory. Once all transmit pulses are completed, volumetric data may be incoherently combined. Data from the differing transmit elements will produce differing noise patterns that will cancel each other out once combined to provide a much clearer 3D ultrasound image.

[0081] FIGS. 4B and 4C illustrate a 3D array being used to collect a 2D slice of data. In the case of FIG. 4B, the slice 320 is along the longitudinal axis of the array. In the case of FIG. 4C, the slice 330 is along the transverse axis of the array. 2D slices may also be obtained at any other angle relative to the probe. In some embodiments, the probe may use a partial line of elements to create transmit aperture T_1 . In some embodiments, elements may be energized in phase to focus a beam onto the plane 320 in FIG. 4B or the plane 330 in FIG. 4C. In these cases, the elements of T_1 may be narrow so that the energy is unfocused in the direction of the plane. The length of the partial line of elements in T_1 may be chosen to be long enough to focus the width of the plane.

[0082] Referring again to FIGS. 4B and 4C, receive aperture R_2 can be used singularly to collect data for longitudinal slice 320. The elements located in aperture R_2 each collect data from the T_1 transmit pulse. Since a speed of sound correction is not required for this type of collection, data from each element may be coherently averaged with the other elements in pre-processing. Subsequently, transmitter groups $T_1, T_2 \dots T_N$ may each be fired to insonify the plane 320 (or 330), each with a different x (or z) position. Partial images of the plane may then be combined either coherently or incoherently with the same considerations as discussed with respect to the embodiments discussed above with reference to FIGS. 2 and 3.

[0083] As discussed above, the view angle and total aperture width can be adjusted. In some embodiments, the view angle may be adjusted in any desired direction along the 3D array.

[0084] With a 3D concave array, a 2D slice angle adjustment may also be provided to allow for selection of a 2D slice to be imaged without having to rotate a probe. A 2D slice angle adjustment may effectively allow rotation of a 2D slice around the y axis to obtain a 2D slice at any angle between that of FIG. 4B and that of FIG. 4C. Similar adjustment may also be provided to allow for a selected 2D slice to be rotated about the x or z axes.

[0085] Thus, the arrays described herein may provide an enormous range of flexibility in selecting and optimizing a 2D image without necessarily moving the probe at all. A 3D array provides mechanically better view angles of the region of interest than conventional coplanar 2D arrays because of its concave curvature and greater total width.

[0086] FIGS. 4D and 4E demonstrate embodiments of a 3D curved array being used for data collection of 3D volumetric data, alternating with a 2D high resolution slice. The sonographer can use a 3D display containing a selectable 2D longitudinal and axial reference line. When in the side-by-side display mode, the 3D image can show the entire volume, and a multiple aperture 2D image can display a high resolution slice for the reference line selected. This is made possible by the array being able to switch between ping transmit from individual elements for volumetric imaging to a shaped pulse transmit (either longitudinally or axially) for 2D slice data for a desired axis. The 2D slice data receives the benefit of concentrated multiple aperture receiving beamforming on a single slice.

[0087] Several embodiments of multi-aperture arrays and their unique transducer housings are described below with reference to FIGS. 5 - 8E. These examples represent some of the flexibility in ultrasound probe design and fabrication that may be achieved when using multi-aperture techniques. The following embodiments provide examples of some general classes of probes (e.g. concave arrays, 3D arrays, conformal and adjustable arrays); however, because of the flexibility in array configuration, a multiple aperture array allows for many conceivable probes to be constructed that are not illustrated here.

[0088] FIG. 5 illustrates one embodiment of a general radiology ultrasound probe with a continuous concave curved transducer array. This probe may be operated according to any of the methods described herein. The radius of curvature of this array may be selected to be sufficiently shallow to allow for imaging a variety of body tissues (e.g., abdomen, pelvis, peripheries, etc.). In some embodiments, the concave probe of FIG. 5 may be used to image in 2D as a curvilinear probe using a 1D array such as that shown in FIG. 5A. The probe of FIG. 5 may also operate in 3D or 4D imaging modalities using a 3D piezoelectric array such as that shown in FIG. 5B or a CMUT array such as that illustrated in FIG. 5C.

[0089] In some embodiments, a concave array such as that shown in FIG. 5 may be substantially rigidly mounted in a probe. Such an array may be held in place

by a backing plate 508. In some embodiments, a single flex connector 505 may be used to electronically connect elements of the transducer array to a cable to be connected to an ultrasound imaging system. In some embodiments, a concave array probe may also include a transmit synchronizer module 502 and probe position displacement sensor 503. In some embodiments, a transmit synchronization module 502 may be used for identifying the start of a transmit pulse when the probe is used as an add-on device with a host machine transmitting. A probe displacement sensor 503 may be an accelerometer, gyroscope or other motion-sensitive device that senses movement of the probe.

[0090] A Calibration Chip 501 may also be provided within the probe. In some embodiments, a calibration chip 501 may store calibration data describing the acoustic position of each transducer element as determined during a probe calibration process. In some embodiments, the calibration chip 501 may include non-volatile memory for storing such calibration data. The calibration chip 501 or another component within the probe may also include communication electronics configured to transmit calibration data to an ultrasound imaging system.

[0091] FIG. 6 is another embodiment of an ultrasound probe with a concave array having significantly smaller radius of curvature than the probe of FIG. 5. In some embodiments, the probe of FIG. 6 may be sized and configured to partially surround a joint or extremity. In some embodiments, the curvature of this array may allow a sonographer to image structures behind bone or other obstructions as discussed above with reference to FIGS. 2B and 2C. Similarly, the probe of FIG. 6 may be used to isolate areas of interest by manually or automatically adjusting the position and/or size of transmit and/or receive apertures without moving the entire probe.

[0092] In some embodiments, the concave array probe of FIG. 6 may be used to image in 2D as a curvilinear probe using a 1D array such as that shown in FIG. 6B. The probe can also operate in 3D or 4D imaging modalities using a 3D piezoelectric array such as that illustrated in FIG. 6C or a CMUT array such as that illustrated in FIG. 6D. Using methods described herein, the probe of FIG. 6 may be used to produce a complete 3D tomographic display of an extremity or joint while a sonographer holds the probe in one position. Such functionality is not possible with conventional ultrasound imaging arrays. In contrast, a conventional array must be moved around the joint, and images taken from a variety of view angles must be compounded together for a 3D presentation. Because of the incongruences of imaging with a coplanar array and manual movement, a tomographic 3D display from a conventional array is typically not physiologically contiguous.

[0093] In some embodiment, the probe of FIG. 6 may be constructed substantially similarly to the probe of FIG. 5. For example, the transducer array(s) may be rigidly mounted to the probe and held in place by a backing plate 508, and may include a flex connector 505. FIG.

6A illustrates an embodiment of a bracelet multiple aperture probe, which may be substantially similar to the probe of FIG. 6, except that the cable connector exits from a side or bottom section of the probe housing. The embodiments of FIGS. 6 and 6A may also include transmit synchronizer modules 502, probe position displacement sensors 503, Calibration Chips 501 and other features discussed elsewhere herein.

[0094] FIG. 7 illustrates an embodiment of a general radiology probe configured to fit into the palm of a sonographer's hand. The probe of FIG. 7 may include a curved array such as those shown in FIGS. 5 and 6. The probe of FIG. 7 is made possible by the ability to construct and calibrate a concave ultrasound transducer array. Probes such as this may significantly reduce ergonomic strain on sonographers. The probe of FIG. 7 may also be constructed with a substantially limited elevation or thickness (e.g., as shown in FIG. 7B). Such reduced thickness may allow a sonographer to reach in behind or underneath patients that cannot be moved and still achieve an image over the areas of interest.

[0095] In some embodiments, the probe of FIG. 7 may include an adjustable hand support for either right or left handed use. In some embodiments, the hand support may be configured to rotate relative to the probe body to allow the sonographer more flexibility. For example, FIG. 7 illustrates the probe with the hand support in a longitudinal orientation, and FIGS. 7A and 7B show the probe with the hand support rotated to a transverse position.

[0096] In some embodiments, the radius of curvature of the array in the probe of FIG. 7 may be adequately shallow to allow for imaging a variety of body tissues (e.g. abdomen, pelvis, peripheries, etc.). The probe of FIG. 7 can image in 2D as a curvilinear probe using a concave 1D array such as that shown in FIG. 7C. The probe of FIG. 7 may also be operated in 3D or 4D imaging modalities using a 3D piezoelectric array such as that shown in FIG. 7D or a CMUT array such as that shown in FIG. 7E.

[0097] FIG. 7F illustrates an embodiment of a 3D piezoelectric or CMUT array that may be used to collect cylindrical volumes of data. The array of FIG. 7F may be operated according to the methods discussed above with reference to FIGS. 4A - 4E.

[0098] In some embodiments, the probe of FIG. 7F may be configured and/or controlled to function as an annular array in which transducer elements are fired in concentric patterns to improve imaging depth.

[0099] As shown in FIG. 7G, embodiments of probes such as that shown in FIGS. 7 - 7G may be constructed substantially similarly to probes discussed above with reference to FIGS. 5 and 6. For example, the FIG. 7 probe may include a backing plate 508, a flex connector 505, transmit synchronizer module 502, a probe position displacement sensor 503, a Calibration Chip 501, and any other suitable components.

[0100] FIG. 8 illustrates one embodiment of an adjustable probe with a plurality of adjustable ultrasound arrays that may be adjusted to conform to a variety of surface

shapes. For example, a sonographer may place the adjustable probe around a physiology of interest, allowing the arrays to conform to the shape of the structure. The sonographer may then lock the arrays into the conformed orientations. Once the arrays are locked in a desired orientation, the probe may be calibrated using a suitable calibration system and the probe may be used to image the physiology of interest.

[0101] FIG. 8 illustrates one embodiment of an array adjustment and locking mechanism. Many other mechanical adjustment and locking mechanisms may alternatively be used. The mechanism of FIG. 8 includes a bellows 810 configured to provide positive pressure on the five adjustable arrays 812, biasing the arrays toward the orientation shown in FIG. 8. The backing blocks 504 of each of the adjustable arrays may be connected to each other by hinge mechanisms 820. As the sonographer places pressure on the probe to overcome the resistance of the bellows, the arrays conform to the shape of the desired physiology as illustrated in FIG. 8A.

[0102] At this time, the sonographer may turn the tightening handle 830 to lock all of the hinge mechanisms in place. The tightening handle may be connected to the hinge mechanisms 820 via hinge cables 840. The cables 840 may comprise an outer conduit 850 and an inner tension wire 860 as illustrated in FIG. 8B. The wire 860 may be attached to a pivot pin 870, and configured such that when the locking ring 830 is rotated, the wire 860 drawn upwards, compressing the pivot pin 870 and hinge 820 for the entire length of the hinge. When the conformed position no longer needed, the tightening handle may be relaxed and the bellows may push all of the arrays out to their fully extended position.

[0103] In some embodiments, each array 812 in the adjustable probe may have its own backing block 504 and flex connector 505. The type of arrays used in an adjustable array can vary. For example, FIG. 8C illustrates an adjustable probe with 1D probes. In some embodiments, an adjustable probe may include transducer arrays of different frequencies. For instance, in some embodiments arrays that use lower frequencies may be located on lateral ends of the probe, and arrays using higher frequencies may be located towards the center. 2D or CMUT arrays may also be used, as shown in FIGS. 8D and 8E. In some embodiments, each array 812 of an adjustable probe may have a planar shape. In other embodiments, each array 812 may have a concave shape with curvature in one or two or more axes.

[0104] An adjustable probe may include similar electronic components to other static-position probes described herein. For example, an adjustable probe may include a Calibration Chip 501, a transmit synchronizer module 502 and probe position displacement sensor 503.

[0105] An adjustable probe such as that shown in FIG. 8 may be operated in 2D, 3D or 4D imaging modalities according to any of the methods described herein.

[0106] Terms such as "optimized," "optimum," "precise," "exact" and similar terms used in relation to quan-

titative parameters are merely intended to indicate design parameters which may be controlled or varied in accordance with general engineering principles. Use of these terms is not intended to imply or require that the parameters or components thereof are designed for the best possible or theoretical performance.

[0107] The above disclosure is sufficient to enable one of ordinary skill in the art to practice the invention, and provides the best mode of practicing the invention presently contemplated by the inventor. While there is provided herein a full and complete disclosure of the preferred embodiments of this invention, it is not desired to limit the invention to the exact construction, dimensional relationships, and operation shown and described.

Claims

1. An ultrasound imaging system, comprising:

a continuous ultrasound transducer array (300), the ultrasound transducer array having a concave curvature about at least one axis;
 a first transmit aperture (T_1) in the ultrasound transducer array comprising a transmitter group of at least one transducer element configured to insonify a scatterer with unfocused ultrasound pings;
 a second transmit aperture (T_2) in the ultrasound transducer array configured to insonify the scatterer with unfocused ultrasound pings;
 a first receive aperture (R_2) in the ultrasound transducer array comprising a first receiver group of transducer elements configured to receive volumetric data from the unfocused ultrasound pings, the first receive aperture being located apart from the first transmit aperture;
 a second receive aperture (R_3) in the ultrasound transducer array comprising a second receiver group of transducer elements configured to receive volumetric data from the unfocused ultrasound pings, the second receive aperture being located apart from the first transmit aperture and the first receive aperture; and
 a control system (140) in electronic communication with the ultrasound transducer array, the control system configured to:

adjust a receive aperture size of the first receive aperture and of the second receive aperture to determine an optimum receive aperture size that retains the best signal to noise ratio while still in phase,
 coherently average the volumetric data from each of the transducer elements of the first receiver group to create a first volume,
 coherently average the volumetric data from each of the transducer elements of the

- second receiver group to create a second volume, and incoherently average the first and second volumes to create a 3D volume, and
- change an aperture view angle of the system by switching from transmitting ultrasound energy with the first transmit aperture to transmitting ultrasound energy with the second transmit aperture, and switching from receiving echoes with the first receive aperture to receiving echoes with the second receive aperture, wherein a transmit/receive angle between the first transmit aperture and the first receive aperture is approximately the same as the transmit/receive angle between the second transmit aperture and the second receive aperture.
2. The system of claim 1, wherein the control system (140) is further configured to access calibration data describing a position and orientation of the first transmit aperture (T_1) and the first receive aperture (R_2).
 3. The system of claim 1, wherein the ultrasound transducer array (300) has a concave curvature about at least two axes.
 4. The system of claim 1, wherein the control system (140) is further configured to access calibration data describing a position and orientation of the at least one transducer element of the first transmit aperture (T_1) and the transducer elements of the first receive aperture (R_2), wherein the calibration data is stored remotely from the control system or in a chip housed within a probe housing along with the array.
 5. The system of claim 1, wherein the control system (140) is configured to change the total aperture size automatically upon detection of an obstruction.
 6. The system of claim 1, wherein the control system (140) is configured to change the aperture view angle automatically upon detection of an obstruction.
 7. The system of claim 1, wherein the first receiver group of transducer elements of the first aperture (R_2) is assembled in a square shape.
 8. The system of claim 7, wherein the second receiver group of transducer elements of the second aperture (R_3) is assembled in a square shape.
 9. A method of ultrasound imaging, comprising:
 - transmitting unfocused ultrasound pings towards a scatterer with first and second transmit apertures (T_1 , T_2) on continuous ultrasound transducer array (300) having a concave curvature about at least one axis;
 - receiving volumetric data from the unfocused ultrasound pings with each of a plurality of transducer elements of a first receive aperture (R_2) located apart from the first transmit aperture on the ultrasound transducer array;
 - receiving volumetric data from the unfocused ultrasound pings with each of a plurality of transducer elements of a second receive aperture (R_3) located apart from the first transmit aperture and the first receive aperture on the ultrasound transducer array;
 - adjusting a receive aperture size of the first receive aperture and of the second receive aperture to determine an optimum receive aperture size that retains the best signal to noise ratio while still in phase;
 - coherently averaging the volumetric data from each of the plurality of transducer elements of the first receive aperture to create a first volume;
 - coherently averaging the volumetric data from each of the plurality of transducer elements of the second receive aperture to create a second volume;
 - incoherently averaging the first and second volumes to create a 3D volume;
 - changing an aperture view angle of the system by switching from transmitting ultrasound energy with the first transmit aperture (T_1) to transmitting ultrasound energy with the second transmit aperture (T_2), and by switching from receiving echoes with the first receive aperture to receiving echoes with the second receive aperture, wherein a transmit/receive angle between the first transmit aperture and the first receive aperture is approximately the same as the transmit/receive angle between the second transmit aperture and the second receive aperture.
 10. The method of claim 9 further comprising obtaining calibration data containing a position and orientation of ultrasound transducer elements in the first transmit aperture (T_1) and the first receive aperture (R_2).
 11. The method of claim 9 further comprising obtaining calibration data containing a position and orientation of ultrasound transducer elements in the second receive aperture (R_3).
 12. The method of claim 9, further comprising detecting an obstruction between the scatterer and the first receive aperture (R_2); and after detecting the obstruction, receiving ultrasound echoes from the scatterer with the second receive aperture (R_3) on the ultrasound transducer array (300), wherein the obstruction is not located between the scatterer and the second receive aperture.

13. The method of claim 12, wherein the detecting step is performed by a sonographer or automatically by a control system (140).

14. The method of claim 12, wherein the transducer array (300) has a concave curvature about at least two axes.

Patentansprüche

1. Ultraschallbildgebungssystem, Folgendes umfassend:

eine kontinuierliche Ultraschallwandleranordnung (300), wobei die Ultraschallwandleranordnung eine konkave Krümmung um wenigstens eine Achse aufweist;
 eine erste Sendeöffnung (T_1) in der Ultraschallwandleranordnung, umfassend eine Sendergruppe aus wenigstens einem Wandlerelement, konfiguriert, einen Streuer mit unkonzentrierten Ultraschall-Pings zu beschallen;
 eine zweite Sendeöffnung (T_2) in der Ultraschallwandleranordnung, konfiguriert, den Streuer mit unkonzentrierten Ultraschall-Pings zu beschallen;
 eine erste Öffnung (R_2) in der Ultraschallwandleranordnung, umfassend eine erste Empfängergruppe aus Wandlerelementen, konfiguriert, volumetrische Daten aus den unkonzentrierten Ultraschall-Pings zu empfangen, wobei die erste Empfangsöffnung von der ersten Sendeöffnung entfernt angeordnet ist;
 eine zweite Öffnung (R_3) in der Ultraschallwandleranordnung, umfassend eine zweite Empfängergruppe aus Wandlerelementen, konfiguriert, volumetrische Daten aus den unkonzentrierten Ultraschall-Pings zu empfangen, wobei die zweite Empfangsöffnung von der ersten Sendeöffnung und der ersten Empfangsöffnung entfernt angeordnet ist; und
 ein Steuersystem (140) in elektronischer Kommunikation mit der Ultraschallwandleranordnung, wobei das Steuersystem konfiguriert ist zum:

Einstellen einer Empfangsöffnungsgröße der ersten Empfangsöffnung und der zweiten Empfangsöffnung zum Bestimmen einer optimalen Empfangsöffnungsgröße, die das beste Signal-Rausch-Verhältnis bereitstellt, während sie weiterhin phasengleich ist,
 kohärenten Mitteln der volumetrischen Daten von jedem der Wandlerelemente der ersten Empfängergruppe zum Erzeugen eines ersten Volumens, kohärenten Mitteln

der volumetrischen Daten von jedem der Wandlerelemente der zweiten Empfängergruppe zum Erzeugen eines zweiten Volumens, und inkohärenten Mitteln des ersten und des zweiten Volumens, um ein 3D-Volumen zu erzeugen, und
 Ändern eines Öffnungsblickwinkels des Systems durch Umschalten vom Senden von Ultraschallenergie mit der ersten Sendeöffnung zum Senden von Ultraschallenergie mit der zweiten Sendeöffnung, und Umschalten vom Empfangen von Echos mit der ersten Empfangsöffnung zum Empfangen von Echos mit der zweiten Empfangsöffnung, wobei ein Sende-/Empfangswinkel zwischen der ersten Sendeöffnung und der ersten Empfangsöffnung nahezu derselbe ist wie der Sende-/Empfangswinkel zwischen der zweiten Sendeöffnung und der zweiten Empfangsöffnung.

2. System nach Anspruch 1, wobei das Steuersystem (140) ferner konfiguriert ist, auf Kalibrierungsdaten zuzugreifen, die eine Position und eine Ausrichtung der ersten Sendeöffnung (T_1) und der ersten Empfangsöffnung (R_2) beschreiben.

3. System nach Anspruch 1, wobei die Ultraschallwandleranordnung (300) eine konkave Krümmung um wenigstens zwei Achsen aufweist.

4. System nach Anspruch 1, wobei das Steuersystem (140) ferner konfiguriert ist, auf Kalibrierungsdaten zuzugreifen, die eine Position und eine Ausrichtung des wenigstens einen Wandlerelements der ersten Sendeöffnung (T_1) und der Wandlerelemente der ersten Empfangsöffnung (R_2) beschreiben, wobei die Kalibrierungsdaten entfernt von dem Steuersystem oder in einem Chip in einem Sondengehäuse gemeinsam mit der Anordnung gespeichert sind.

5. System nach Anspruch 1, wobei das Steuersystem (140) konfiguriert ist, die Gesamtöffnungsgröße nach Erfassen eines Hindernisses automatisch zu ändern.

6. System nach Anspruch 1, wobei das Steuersystem (140) konfiguriert ist, den Blickwinkel der Öffnungsgröße nach Erfassen eines Hindernisses automatisch zu ändern.

7. System nach Anspruch 1, wobei die erste Empfängergruppe aus Wandlerelementen der ersten Öffnung (R_2) in einer quadratischen Form angeordnet ist.

8. System nach Anspruch 7, wobei die zweite Empfängergruppe aus Wandlerelementen der zweiten Öff-

nung (R_3) in einer quadratischen Form angeordnet ist.

9. Verfahren für Ultraschallbildgebung, Folgendes umfassend:

Senden von unkonzentrierten Ultraschall-Pings hin zu einem Streuer mit einer ersten und einer zweiten Sendeöffnung (T_1 , T_2) an eine kontinuierliche Ultraschallwandleranordnung (300) mit einer konkaven Krümmung um wenigstens eine Achse;

Empfangen von volumetrischen Daten aus den unkonzentrierten Ultraschall-Pings mit jedem von mehreren Wandlerelementen einer ersten Empfangsöffnung (R_2), die entfernt von der ersten Sendeöffnung der Ultraschallwandleranordnung angeordnet ist;

Empfangen von volumetrischen Daten aus den unkonzentrierten Ultraschall-Pings mit jedem von mehreren Wandlerelementen einer ersten Empfangsöffnung (R_3), die entfernt von der ersten Sendeöffnung der Ultraschallwandleranordnung angeordnet ist;

Einstellen einer Empfangsöffnungsgröße der ersten Empfangsöffnung und der zweiten Empfangsöffnung zum Bestimmen einer optimalen Empfangsöffnungsgröße, die das beste Signal-Rausch-Verhältnis bereitstellt, während sie weiterhin phasengleich ist;

kohärentes Mitteln der volumetrischen Daten von jedem der mehreren Wandlerelemente der ersten Empfangsöffnung zum Erzeugen eines ersten Volumens;

kohärentes Mitteln der volumetrischen Daten von jedem der mehreren Wandlerelemente der zweiten Empfangsöffnung zum Erzeugen eines zweiten Volumens;

inkohärentes Mitteln des ersten und des zweiten Volumens, um ein 3D-Volumen zu erzeugen;

Ändern eines Öffnungsblickwinkels des Systems durch Umschalten vom Senden von Ultraschallenergie mit der ersten Sendeöffnung (T_1) zum Senden von Ultraschallenergie mit der zweiten Sendeöffnung (T_2), und durch Umschalten vom Empfangen von Echos mit der ersten Empfangsöffnung zum Empfangen von Echos mit der zweiten Empfangsöffnung, wobei ein Sende-/Empfangswinkel zwischen der ersten Sendeöffnung und der ersten Empfangsöffnung nahezu derselbe ist wie der Sende-/Empfangswinkel zwischen der zweiten Sendeöffnung und der zweiten Empfangsöffnung.

10. Verfahren nach Anspruch 9, ferner umfassend das Erhalten von Kalibrierungsdaten, die eine Position und eine Ausrichtung von Ultraschallwandlerelementen in der ersten Sendeöffnung (T_1) und der ers-

ten Empfangsöffnung (R_2) enthalten.

11. Verfahren nach Anspruch 9, ferner umfassend das Erhalten von Kalibrierungsdaten, die eine Position und eine Ausrichtung von Ultraschallwandlerelementen in der zweiten Empfangsöffnung (R_3) enthalten.

12. Verfahren nach Anspruch 9, ferner Folgendes umfassend:

Erfassen eines Hindernisses zwischen dem Streuer und der ersten Empfangsöffnung (R_2); und

nach dem Erfassen des Hindernisses, Empfangen von Ultraschallechos von dem Streuer mit der zweiten Empfangsöffnung (R_3) der Ultraschallwandleranordnung (300), wobei das Hindernis nicht zwischen dem Streuer und der zweiten Empfangsöffnung angeordnet ist.

13. Verfahren nach Anspruch 12, wobei der Erfassungsschritt durch einen Ultraschalldiagnostiker oder automatisch durch ein Steuersystem (140) ausgeführt wird.

14. Verfahren nach Anspruch 12, wobei die Wandleranordnung (300) eine konkave Krümmung um wenigstens zwei Achsen aufweist.

Revendications

1. Système d'imagerie par ultrasons, comprenant :

un réseau continu de transducteurs à ultrasons (300), le réseau de transducteurs à ultrasons comportant une courbure concave autour d'au moins un axe ;

une première ouverture de transmission (T_1) dans le réseau de transducteurs à ultrasons comprenant un groupe d'émetteurs d'au moins un élément de transducteurs conçu pour insonifier un diffuseur avec des impulsions ultrasonores non focalisées ;

une seconde ouverture de transmission (T_2) dans le réseau de transducteurs à ultrasons conçue pour insonifier le diffuseur avec des impulsions ultrasonores non focalisées ;

une première ouverture de réception (R_2) dans le réseau de transducteurs à ultrasons comprenant un premier groupe de récepteurs d'éléments de transducteurs conçus pour recevoir des données volumétriques provenant des impulsions ultrasonores non focalisées, la première ouverture de réception étant située en dehors de la première ouverture de transmission ;

une seconde ouverture de réception (R_3) dans

le réseau de transducteurs à ultrasons comprenant un second groupe de récepteurs d'éléments de transducteurs conçus pour recevoir des données volumétriques provenant des impulsions ultrasonores non focalisées, la seconde ouverture de réception étant située en dehors de la première ouverture de transmission et de la première ouverture de réception ; et un système de commande (140) en communication électronique avec le réseau de transducteurs à ultrasons, le système de commande étant conçu pour :

régler une taille d'ouverture de réception de la première ouverture de réception et de la seconde ouverture de réception afin de déterminer une taille optimale d'ouverture de réception qui retient le meilleur rapport signal/bruit tout en restant en phase, faire la moyenne de manière cohérente des données volumétriques provenant de chacun des éléments de transducteurs du premier groupe de récepteurs afin de créer un premier volume, faire la moyenne de manière cohérente des données volumétriques provenant de chacun des éléments de transducteurs du second groupe de récepteurs afin de créer un second volume, et faire la moyenne de manière incohérente des premier et second volumes afin de créer un volume tridimensionnel, et changer un angle de vue d'ouverture du système en remplaçant la transmission d'énergie ultrasonore avec la première ouverture de transmission par la transmission d'énergie ultrasonore avec la seconde ouverture de transmission, et en remplaçant la réception d'échos avec la première ouverture par la réception d'échos avec la seconde ouverture de réception, un angle de transmission/réception entre la première ouverture de transmission et la première ouverture de réception étant approximativement le même que l'angle de transmission/réception entre la seconde ouverture de transmission et la seconde ouverture de réception.

2. Système selon la revendication 1, dans lequel le système de commande (140) est en outre conçu pour accéder à des données de calibration décrivant une position et une orientation de la première ouverture de transmission (T_1) et la première ouverture de réception (R_2).
3. Système selon la revendication 1, dans lequel le réseau de transducteurs à ultrasons (300) comporte une courbure concave autour d'au moins deux axes.

4. Système selon la revendication 1, dans lequel le système de commande (140) est en outre conçu pour accéder à des données de calibration décrivant une position et une orientation de l'au moins un élément de transducteurs de la première ouverture de transmission (T_1) et des éléments de transducteurs de la première ouverture de réception (R_2), les données de calibration étant stockées à distance du système de commande ou dans une puce logée à l'intérieur d'un boîtier de sonde conjointement au réseau.

5. Système selon la revendication 1, dans lequel le système de commande (140) est conçu pour changer de manière automatique la taille d'ouverture totale après la détection d'une obstruction.

6. Système selon la revendication 1, dans lequel le système de commande (140) est conçu pour changer de manière automatique l'angle de vue d'ouverture après la détection d'une obstruction.

7. Système selon la revendication 1, dans lequel le premier groupe de récepteurs d'éléments de transducteurs de la première ouverture (R_2) est assemblé en une forme carrée.

8. Système selon la revendication 7, dans lequel le second groupe de récepteurs d'éléments de transducteurs de la seconde ouverture (R_3) est assemblé en une forme carrée.

9. Procédé d'imagerie par ultrasons, comprenant :

la transmission d'impulsions ultrasonores non focalisées en direction d'un diffuseur avec les première et seconde ouvertures de transmission (T_1 , T_2) sur un réseau continu de transducteurs à ultrasons (300) comportant une courbure concave autour d'au moins un axe ;

la réception de données volumétriques provenant des impulsions ultrasonores non focalisées avec chacun d'une pluralité d'éléments de transducteurs d'une première ouverture de réception (R_2) située en dehors de la première ouverture de transmission sur le réseau de transducteurs à ultrasons ;

la réception de données volumétriques provenant des impulsions ultrasonores non focalisées avec chacun d'une pluralité d'éléments de transducteurs d'une seconde ouverture de réception (R_3) située en dehors de la première ouverture de transmission et de la première ouverture de réception sur le réseau de transducteurs à ultrasons ;



le réglage d'une taille d'ouverture de réception de la première ouverture de réception et de la seconde ouverture de réception afin de déterminer une taille optimale d'ouverture de réception.

- tion qui retient le meilleur rapport au signal/bruit tout en restant en phase ;
 le calcul de la moyenne de manière cohérente des données volumétriques à partir de chacun de la pluralité d'éléments de transducteurs de la première ouverture de réception afin de créer un premier volume ;
 le calcul de la moyenne de manière cohérente des données volumétriques à partir de chacun de la pluralité d'éléments de transducteurs de la seconde ouverture de réception afin de créer un second volume ;
 le calcul de la moyenne de manière incohérente des premier et second volumes afin de créer un volume tridimensionnel ;
 le changement d'un angle de vue d'ouverture du système en remplaçant la transmission d'énergie ultrasonore avec la première ouverture de transmission (T_1) par la transmission d'énergie ultrasonore avec la seconde ouverture de transmission (T_2), et en remplaçant la réception d'échos avec la première ouverture de réception par la réception d'échos avec la seconde ouverture de réception, un angle de transmission/réception entre la première ouverture de transmission et la première ouverture de réception étant approximativement le même que l'angle de transmission/réception entre la seconde ouverture de transmission et la seconde ouverture de réception.
10. Procédé selon la revendication 9, comprenant en outre l'obtention de données de calibration contenant une position et une orientation d'éléments de transducteurs à ultrasons dans la première ouverture de transmission (T_1) et la première ouverture de réception (R_2).
11. Procédé selon la revendication 9, comprenant en outre l'obtention de données de calibration contenant une position et une orientation d'éléments de transducteurs à ultrasons dans la seconde ouverture de réception (R_3).
12. Procédé selon la revendication 9, comprenant en outre la détection d'une obstruction entre le diffuseur et la première ouverture de réception (R_2) ; et après la détection de l'obstruction, la réception d'échos ultrasonores provenant du diffuseur pourvus de la seconde ouverture de réception (R_3) sur le réseau de transducteurs à ultrasons (300), l'obstruction n'étant pas située entre le diffuseur et la seconde ouverture de réception.
13. Procédé selon la revendication 12, dans lequel l'étape de détection est réalisée au moyen d'un échographiste ou de manière automatique au moyen d'un système de commande (140).
14. Procédé selon la revendication 12, dans lequel le réseau de transducteurs (300) comporte une courbure concave autour d'au moins deux axes.

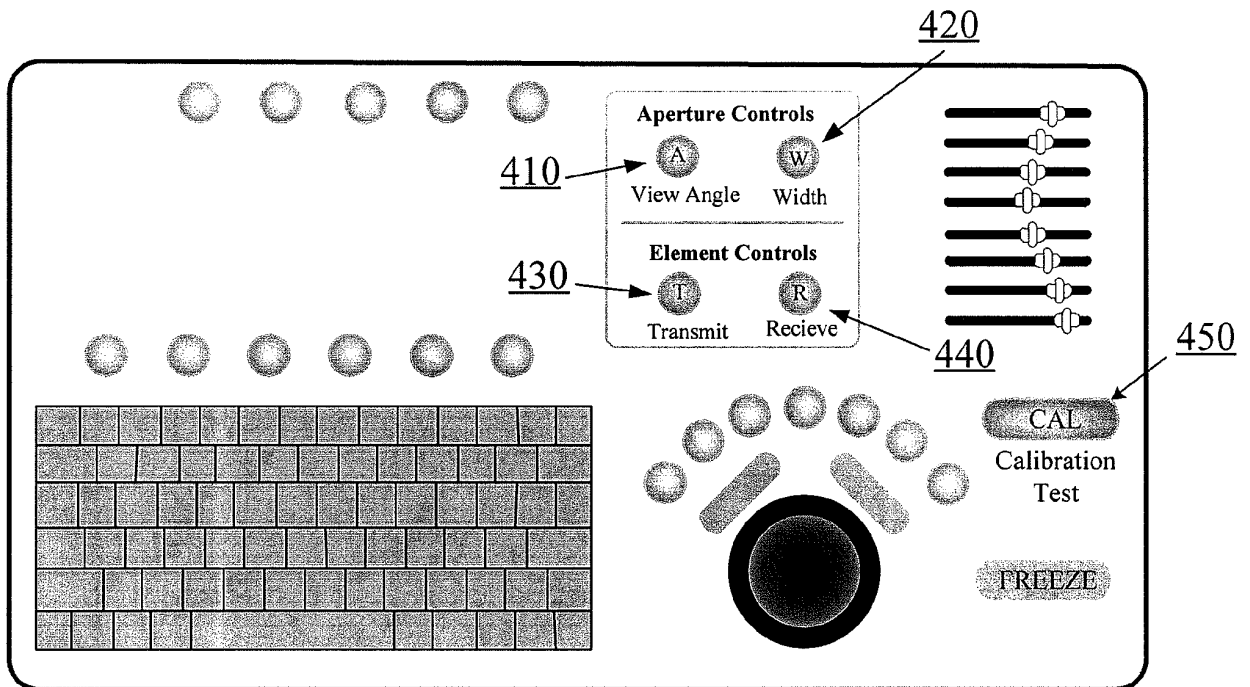
FIG. 1

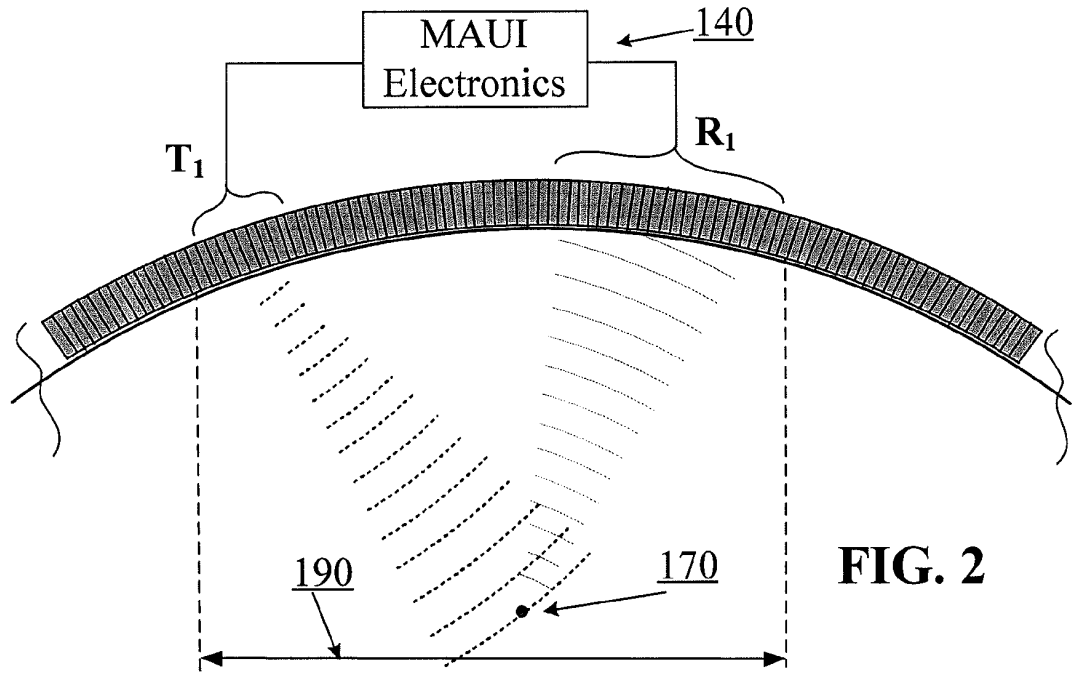

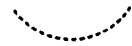

Transmitted Energy 
Reflected Energy 

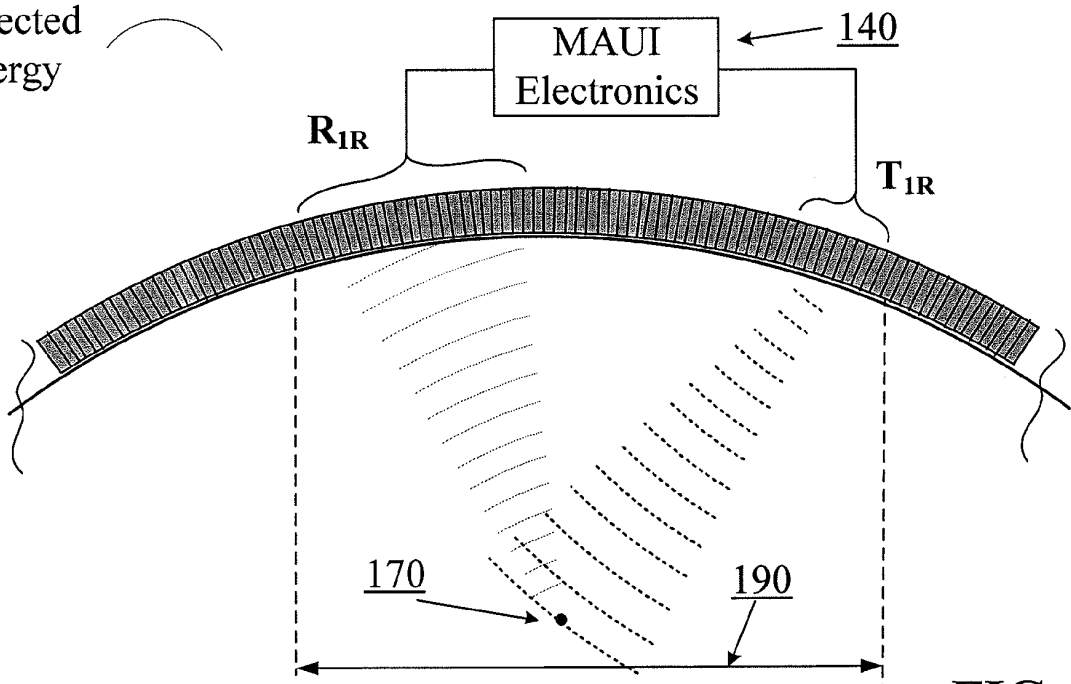

FIG. 2B

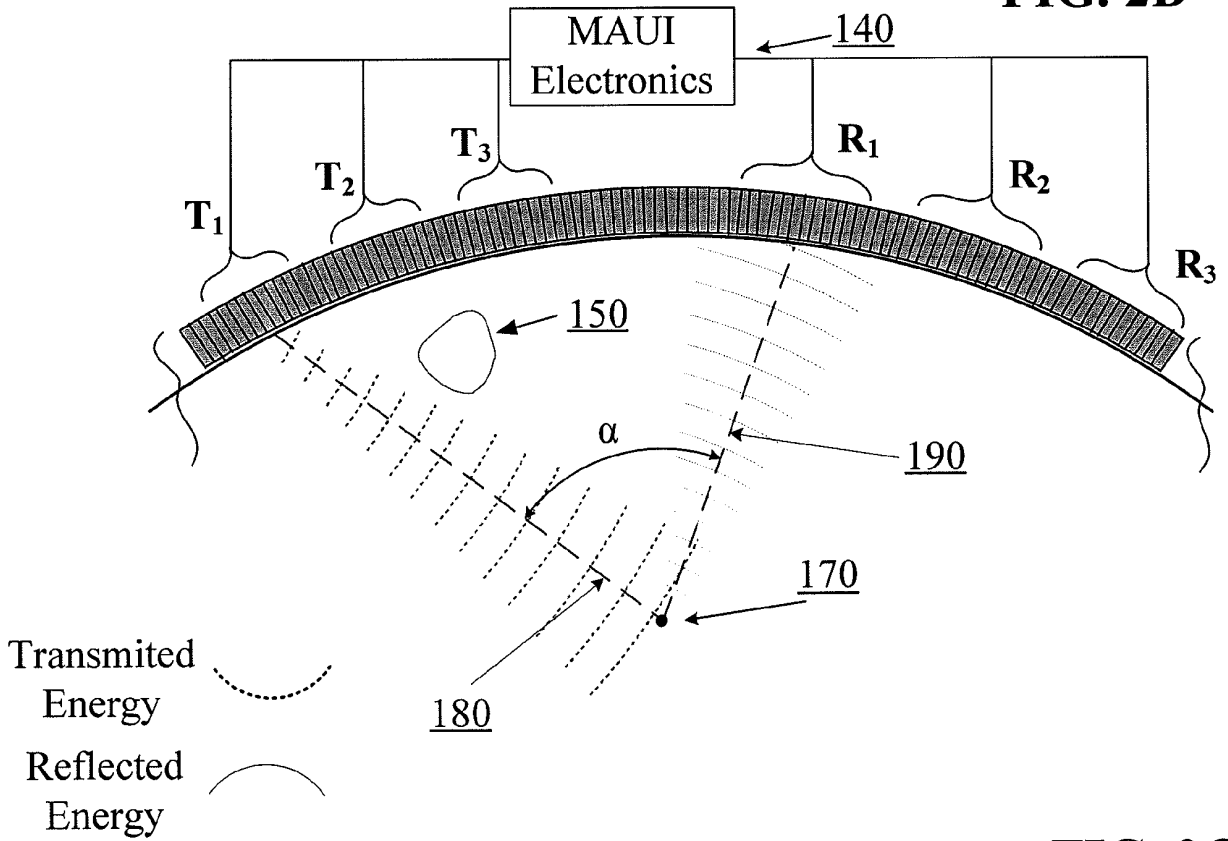
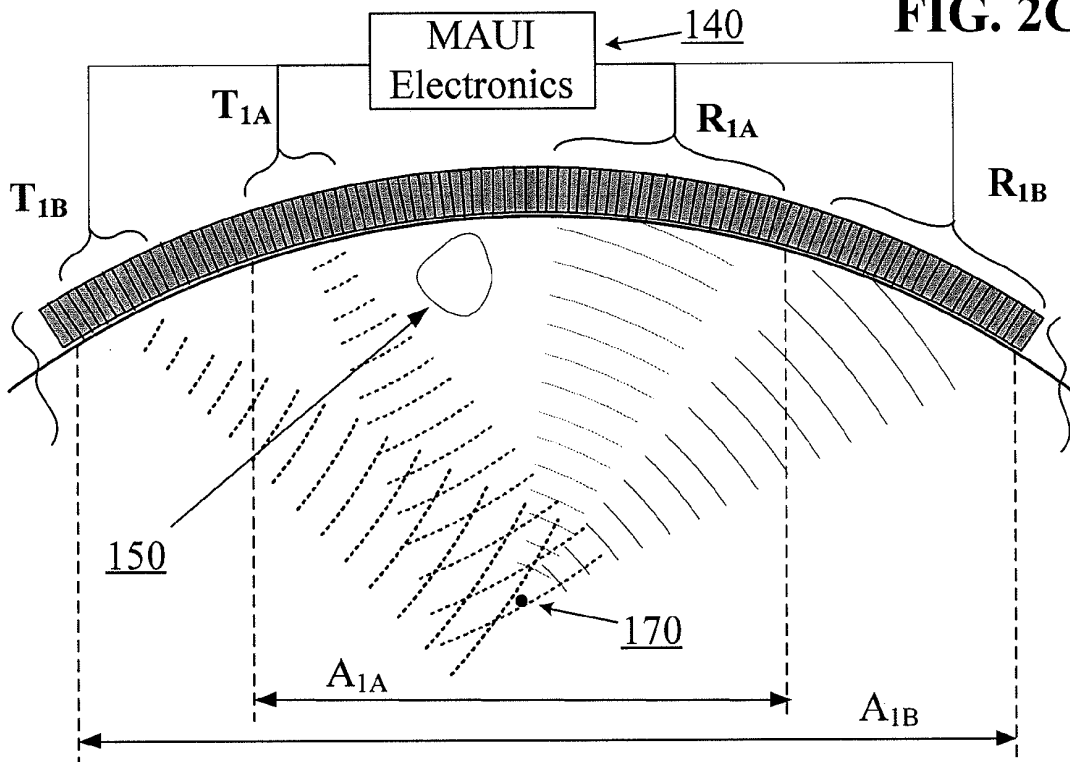
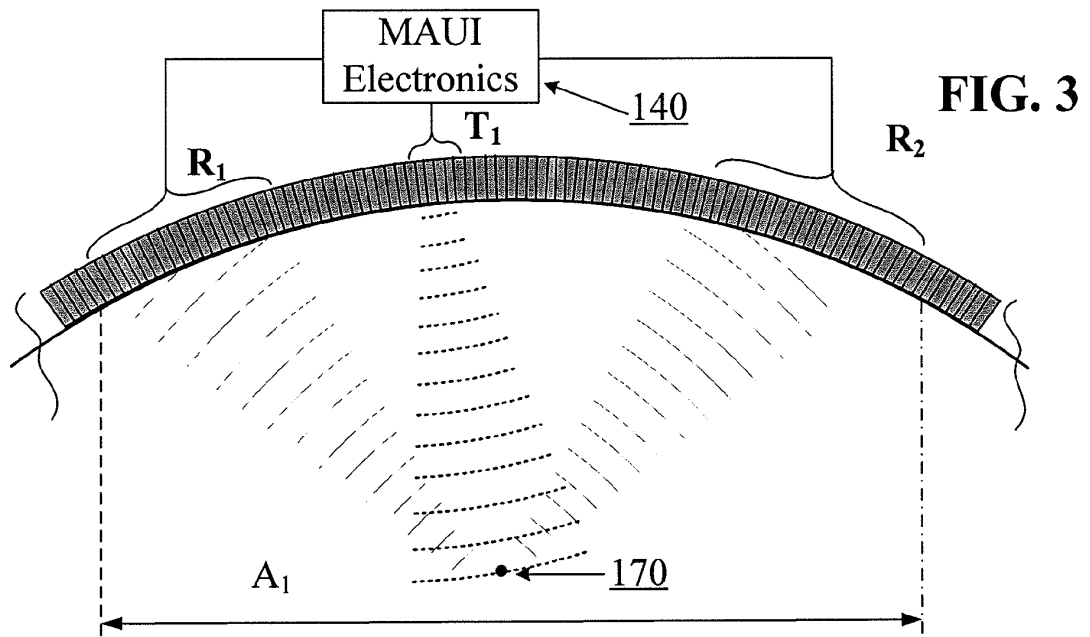

FIG. 2C





Transmitted Energy
Reflected Energy

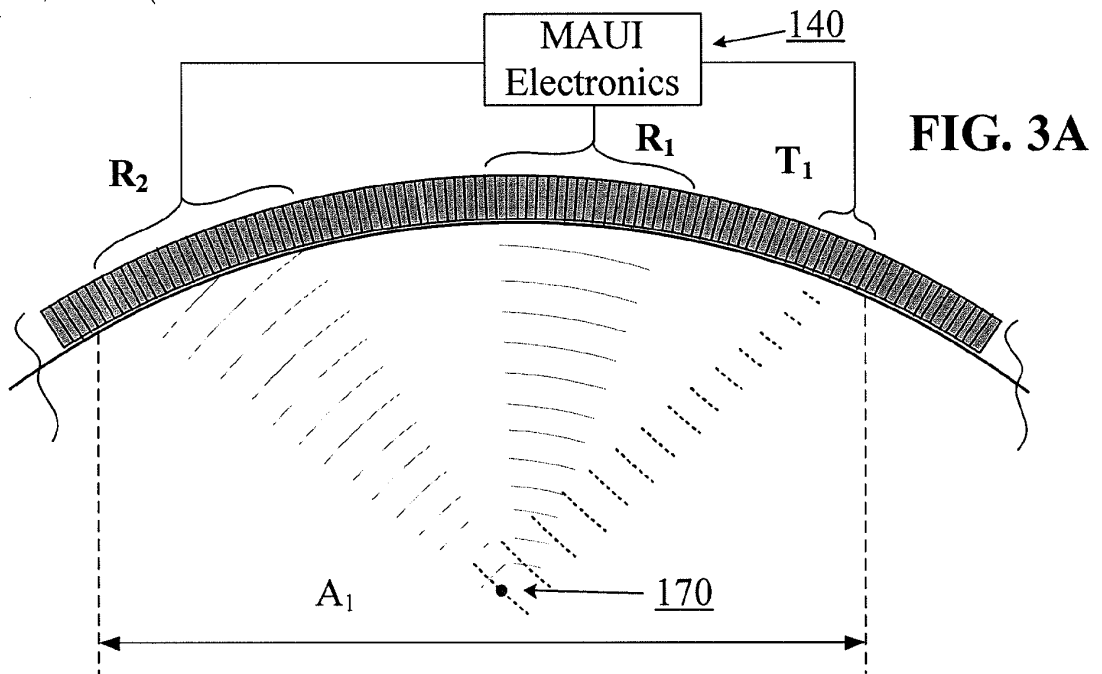

FIG. 4

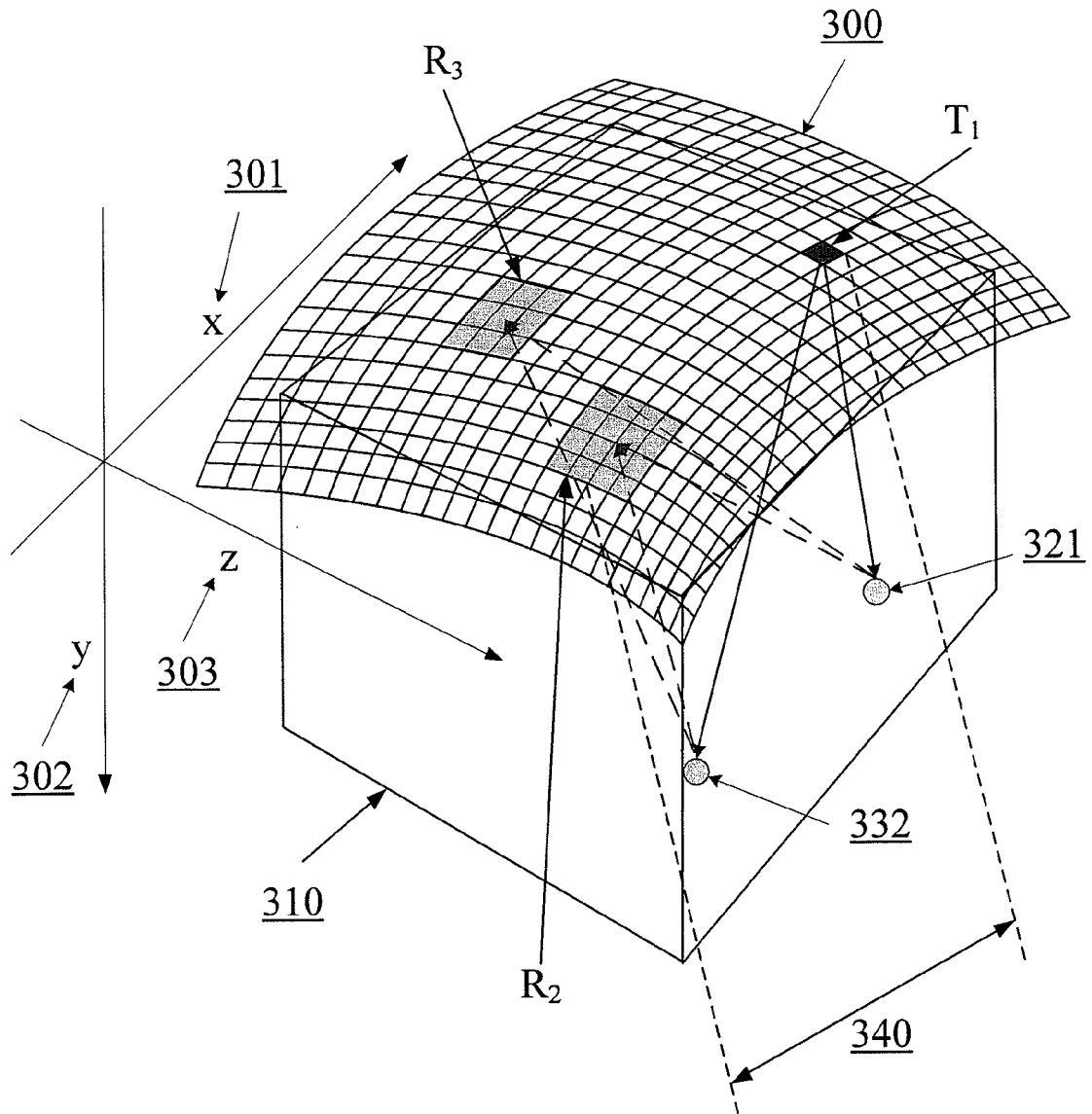
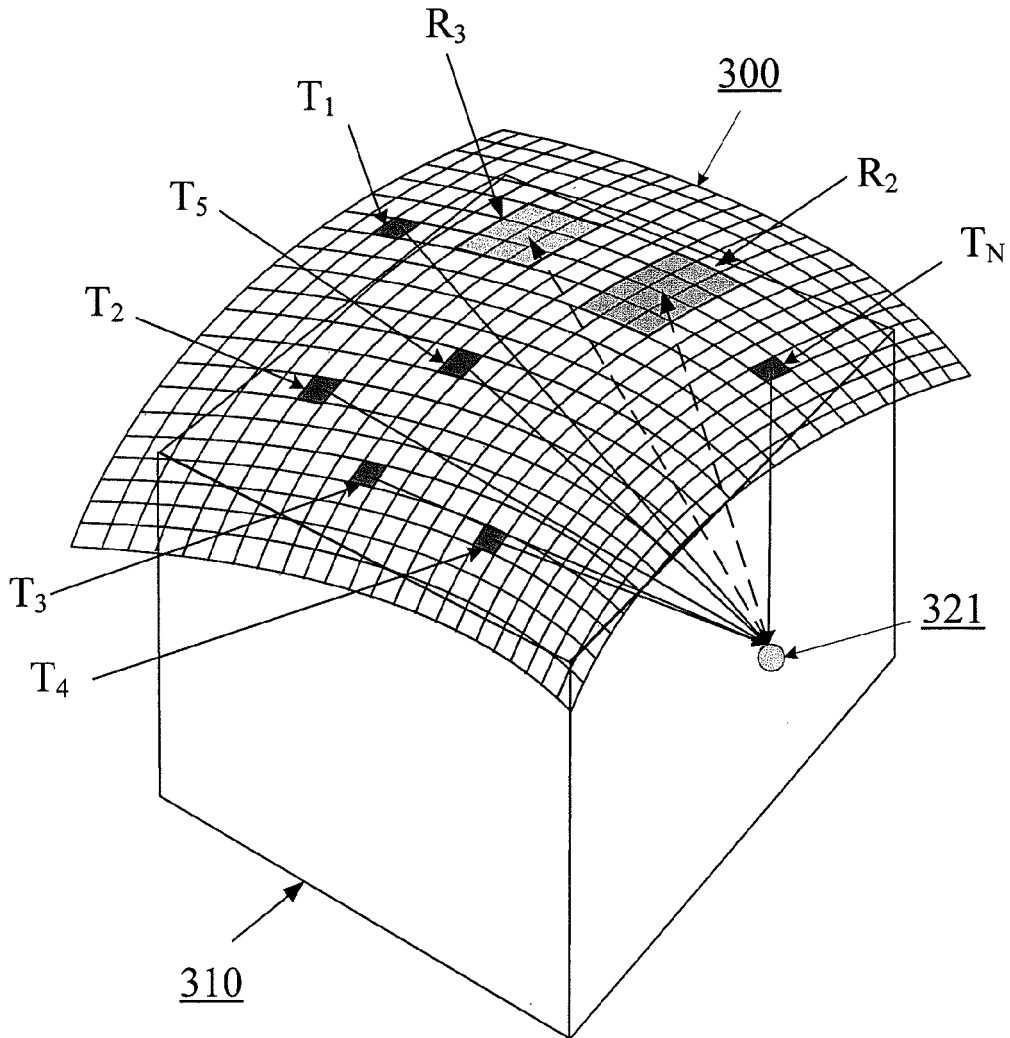

FIG. 4A



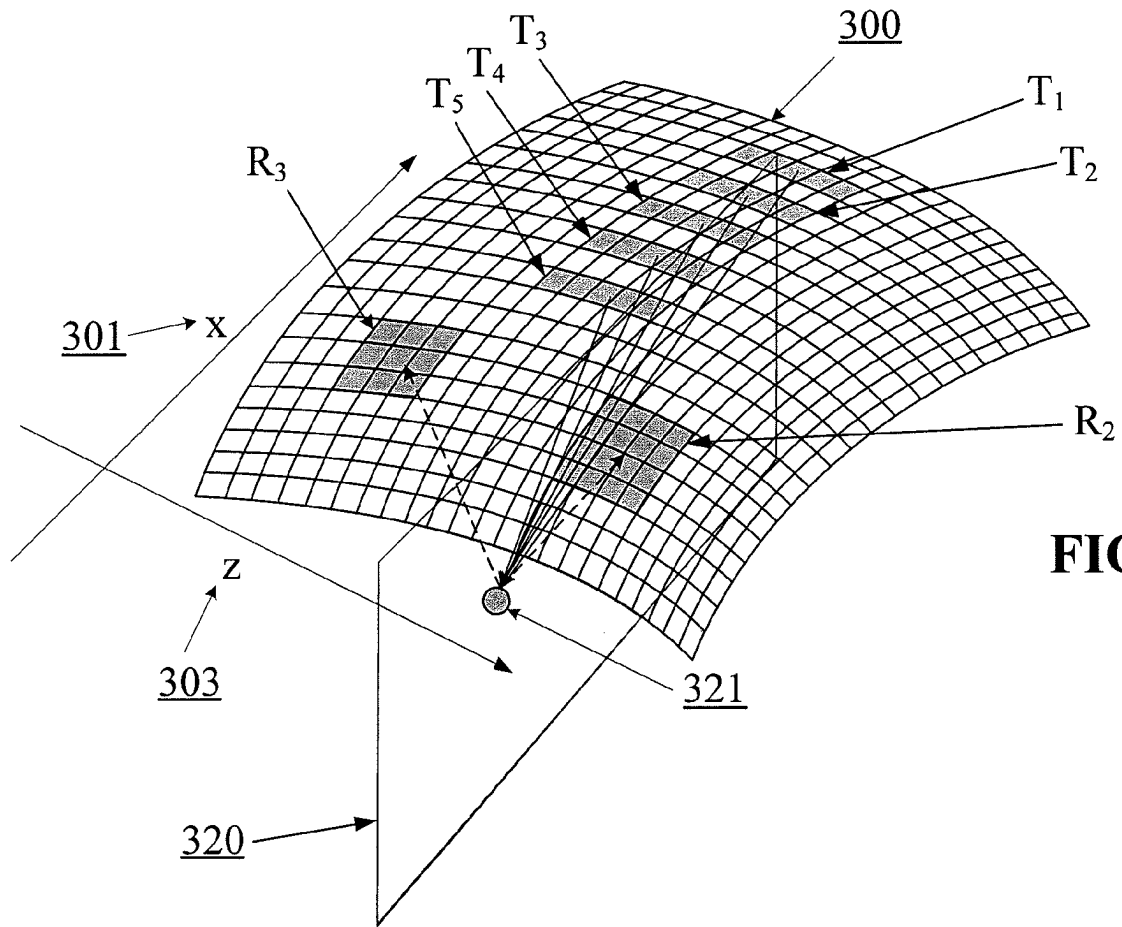

FIG. 4B

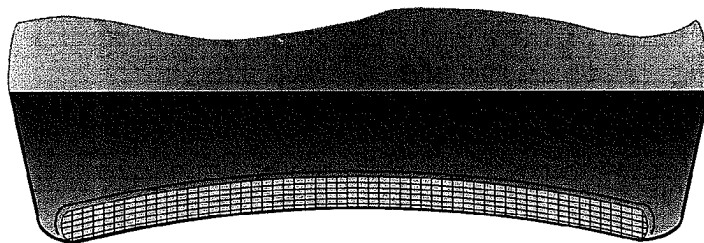
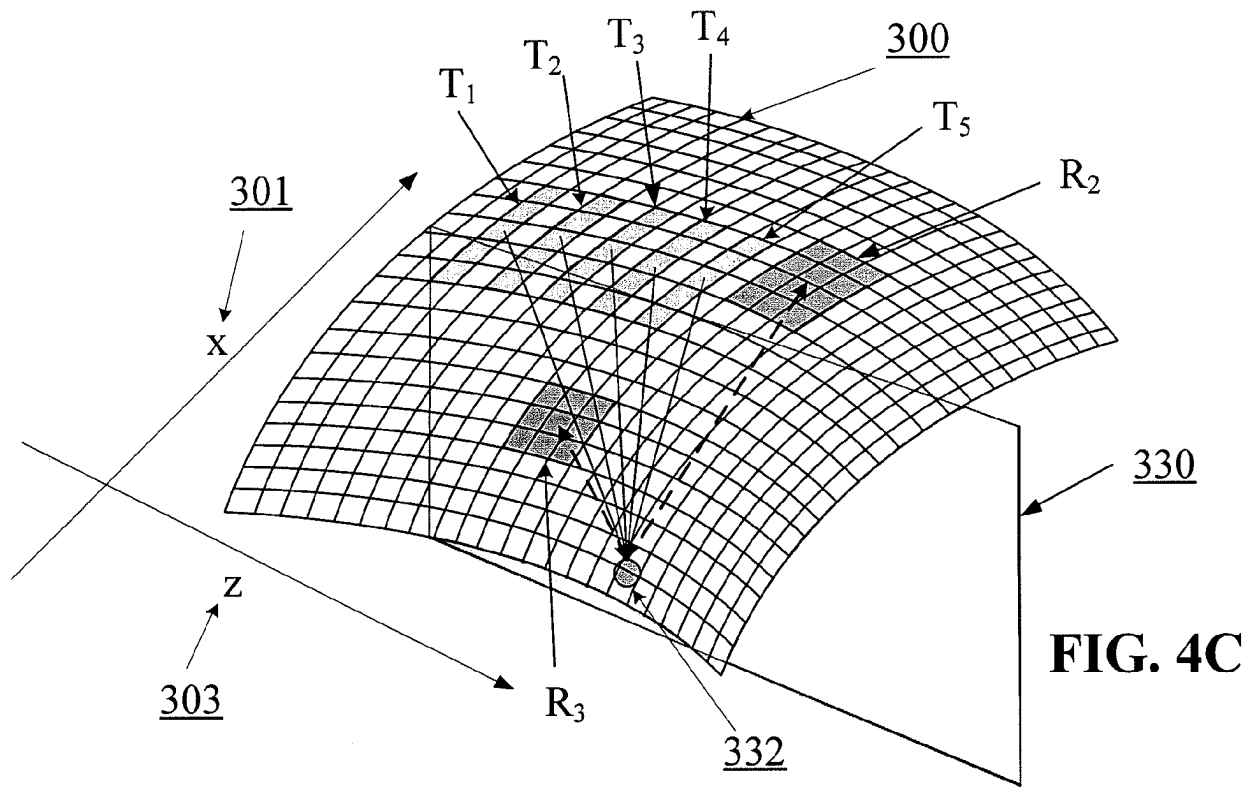
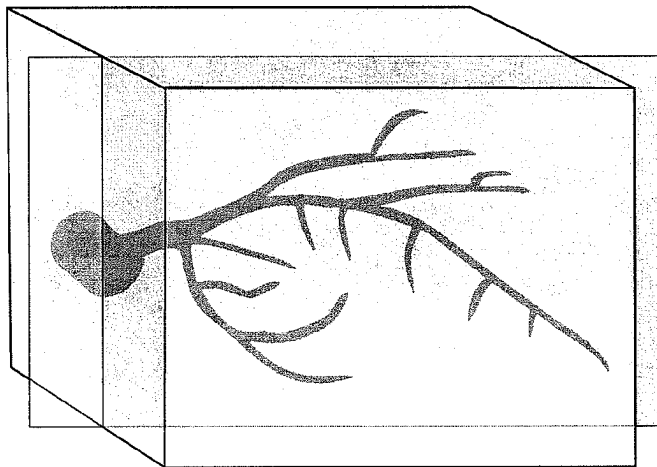

FIG. 4D



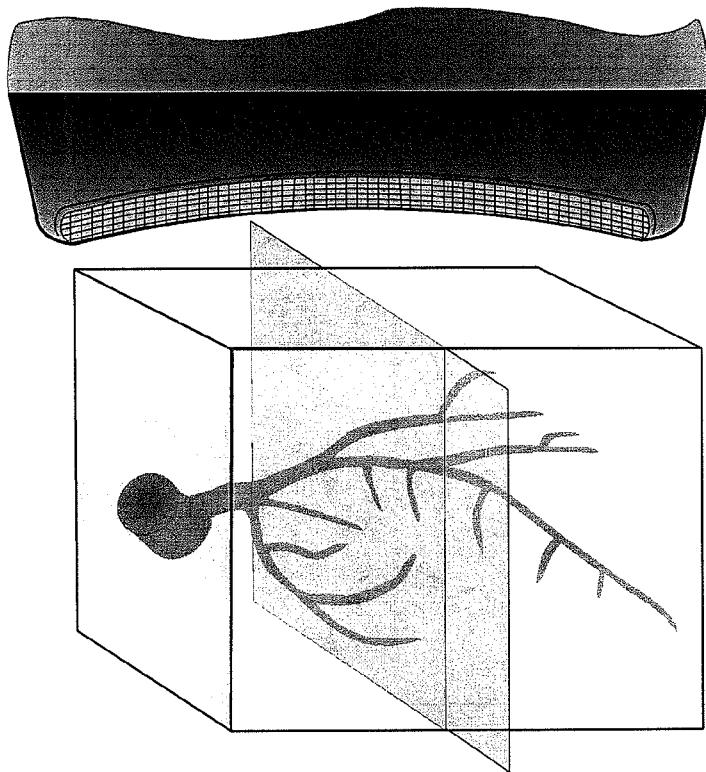
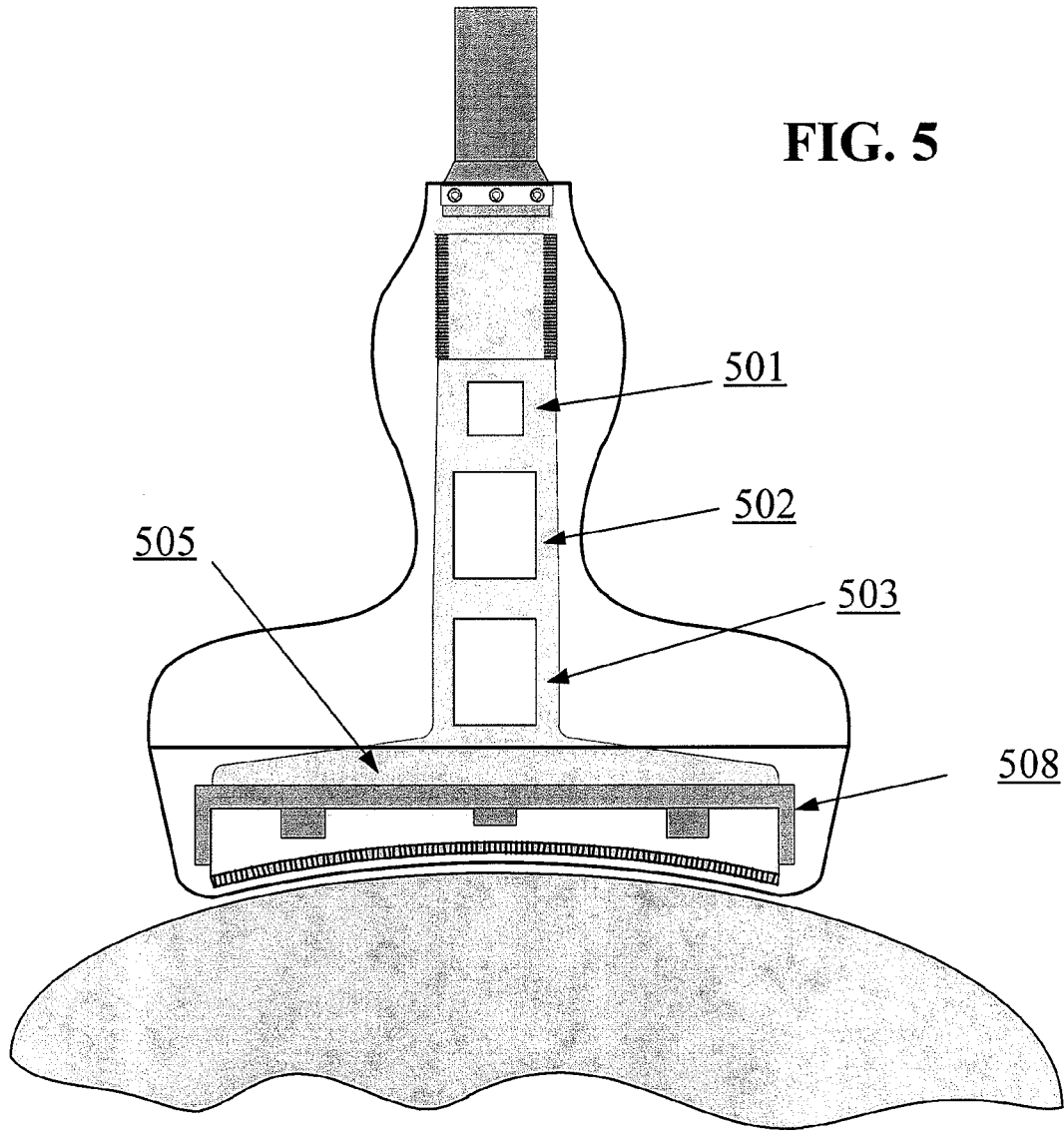

FIG. 4E



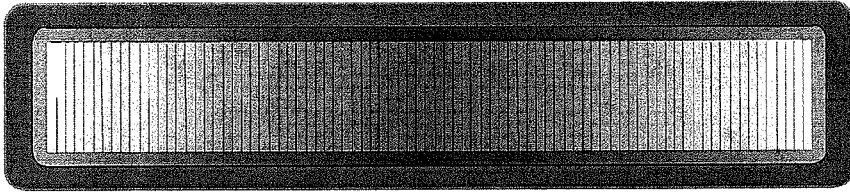

FIG. 5A

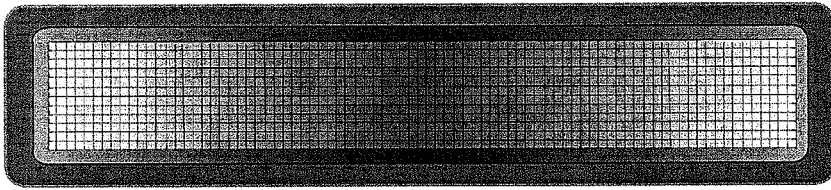

FIG. 5B

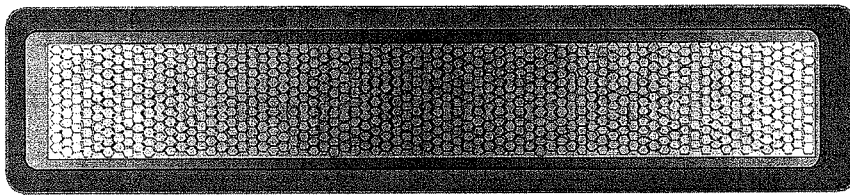

FIG. 5C

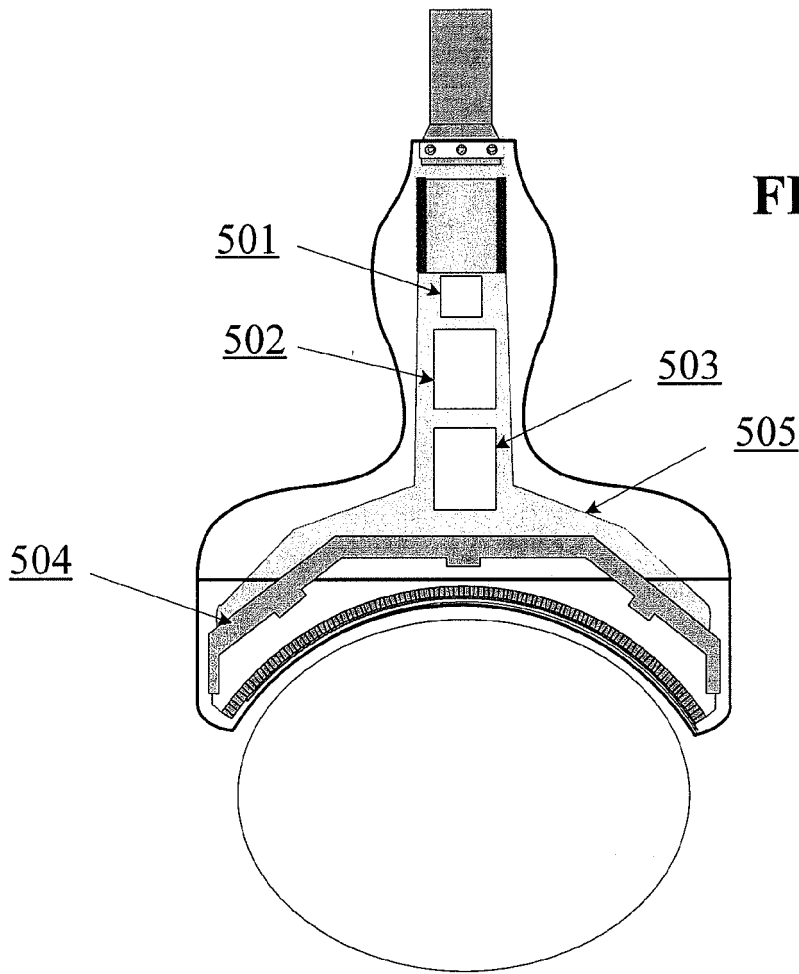

FIG. 6

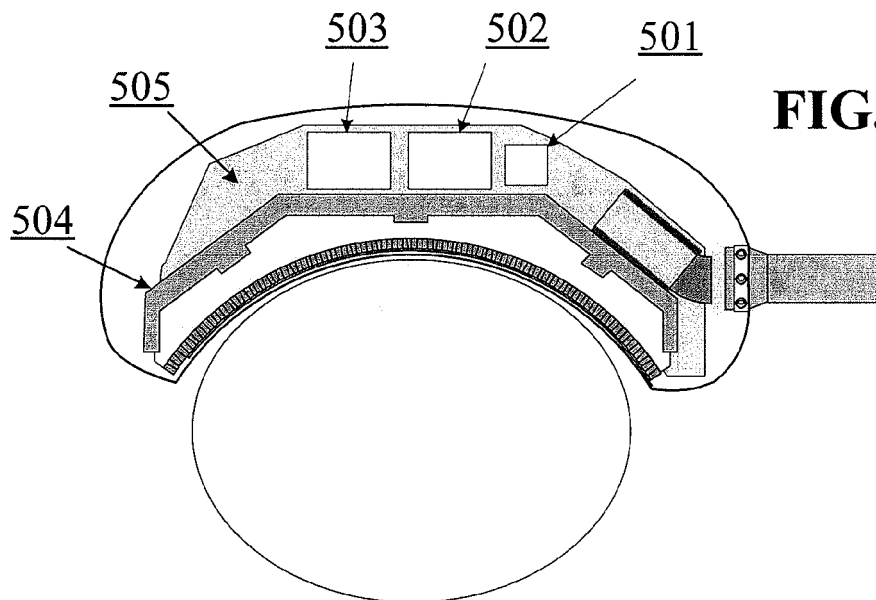
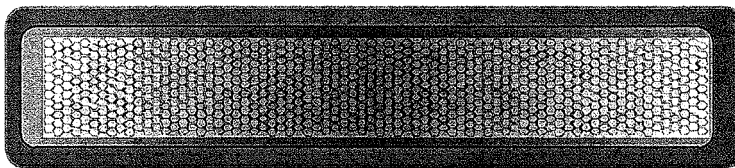
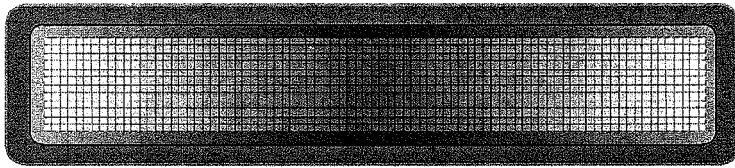
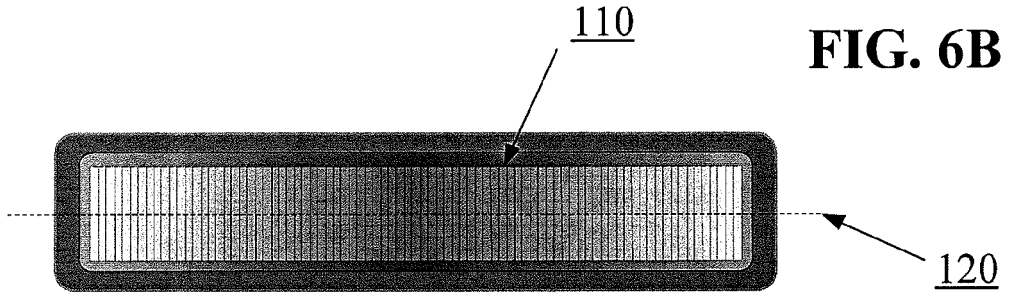

FIG. 6A



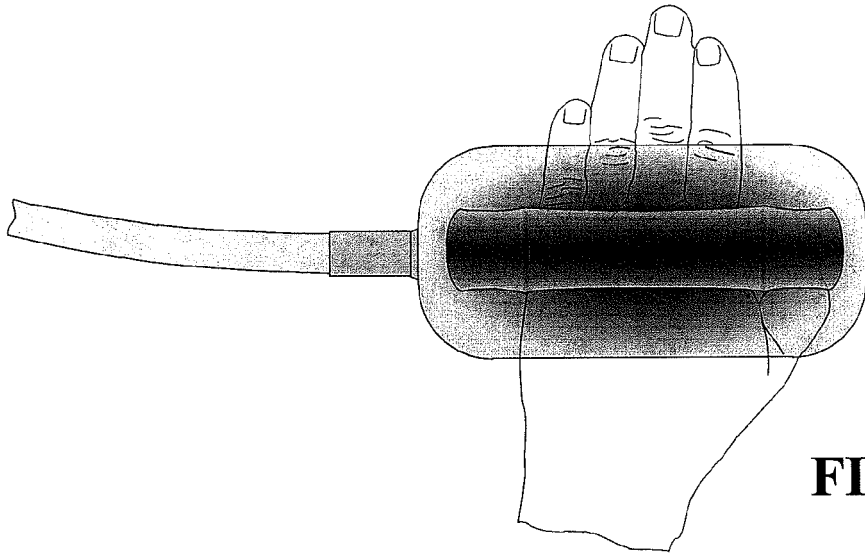

FIG. 7

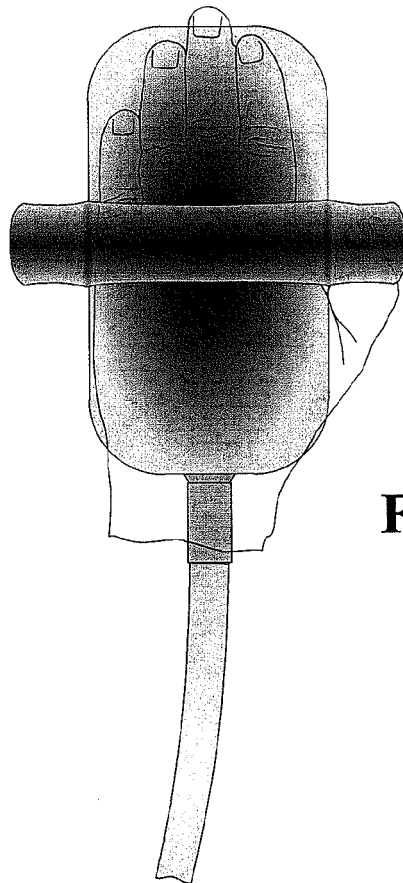

FIG. 7A

FIG. 7B

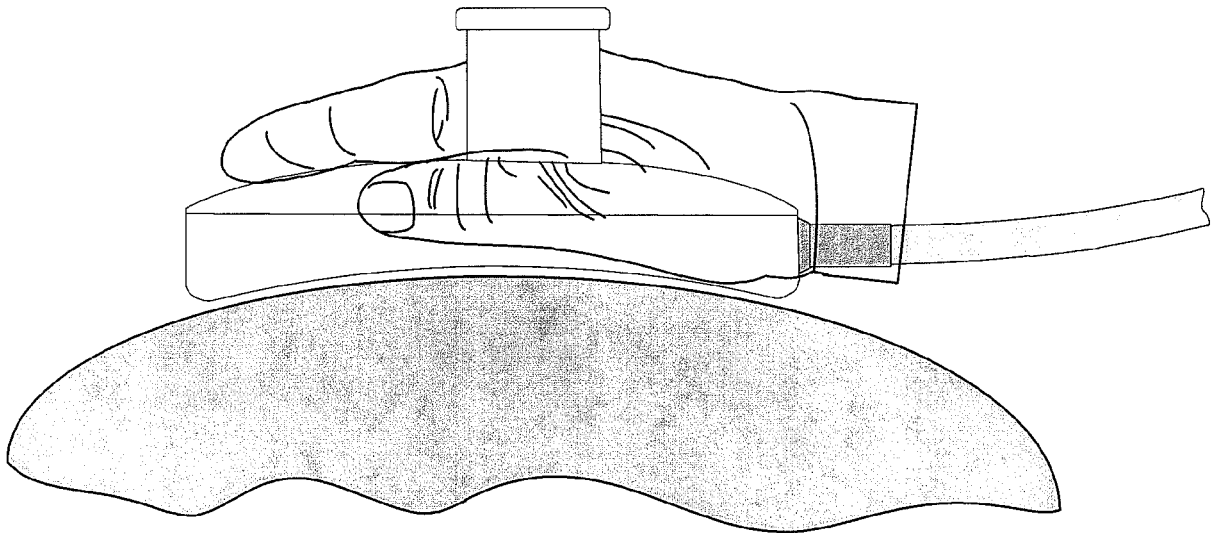

FIG. 7C

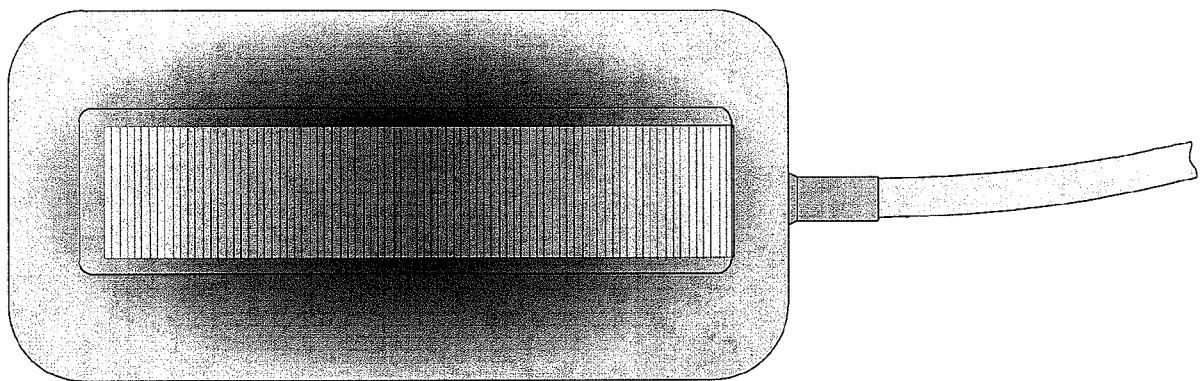

FIG. 7D

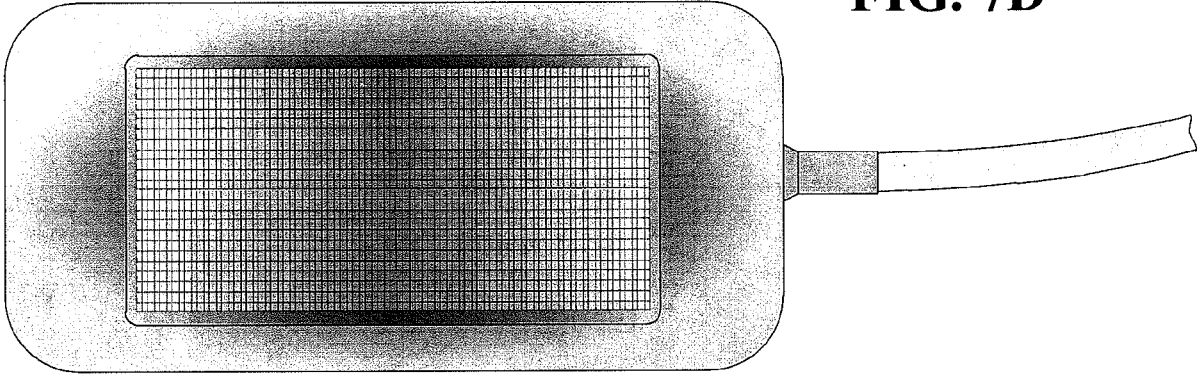
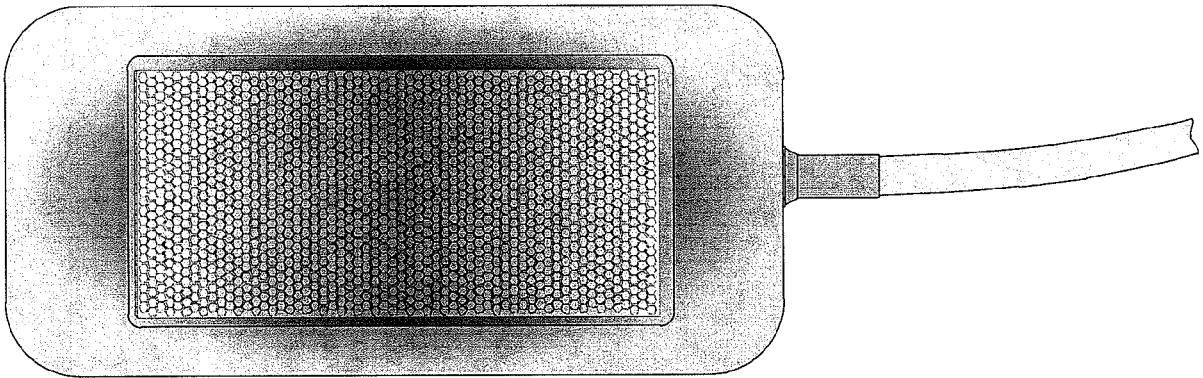

FIG. 7E



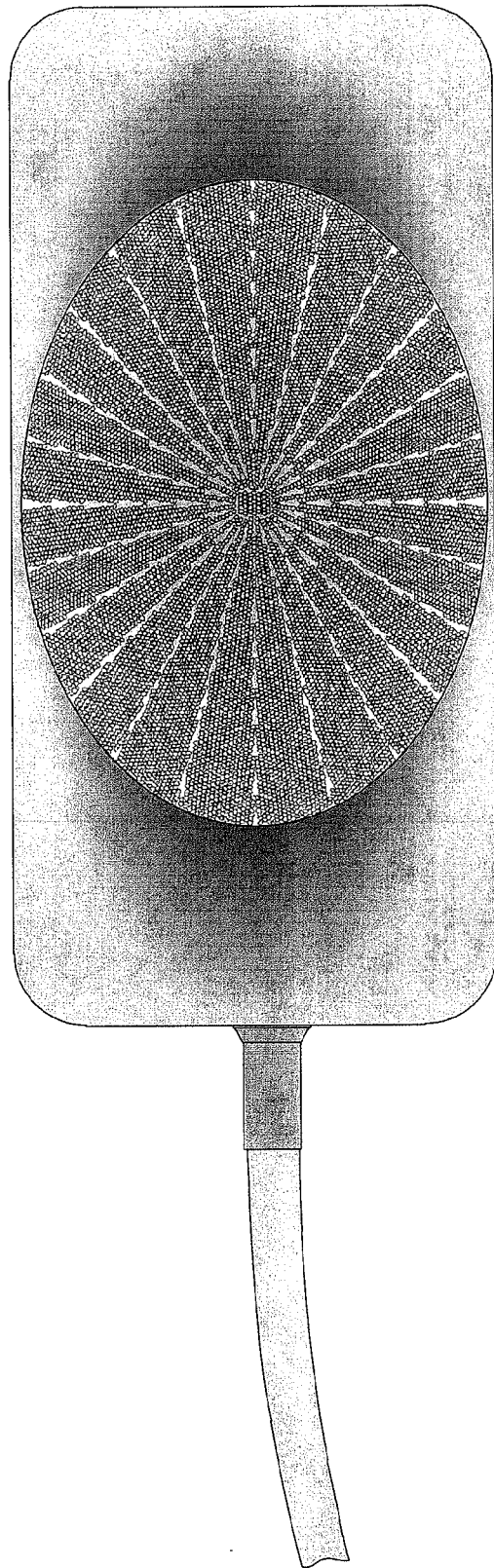

FIG. 7F

FIG. 7G

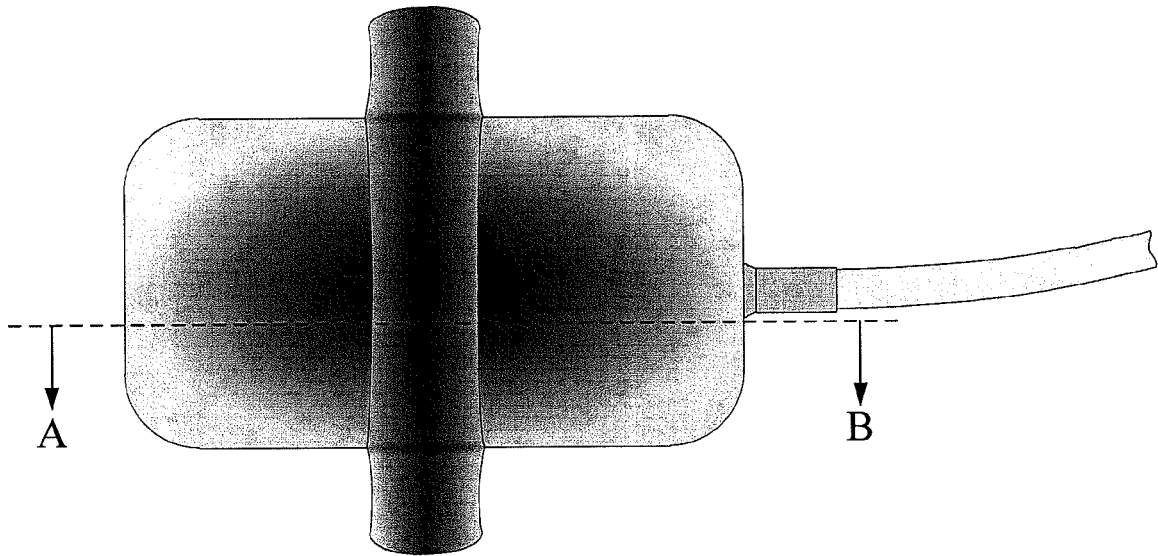

FIG. 7H

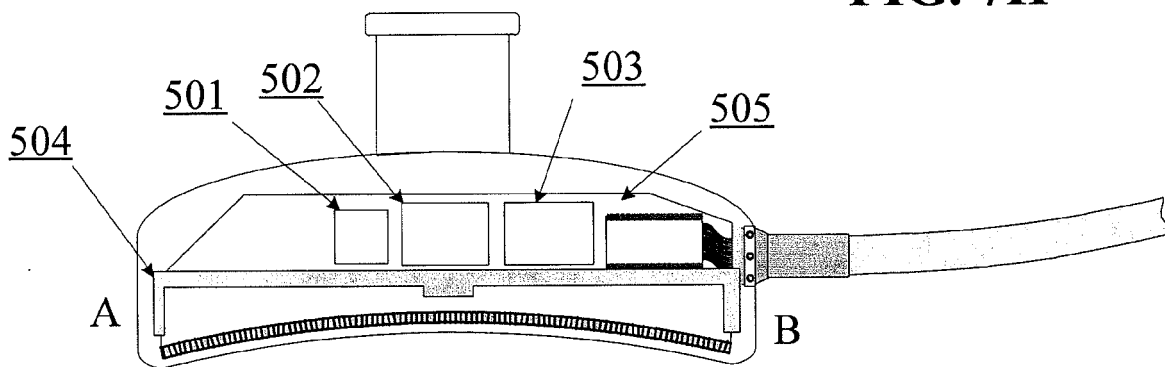

FIG. 8

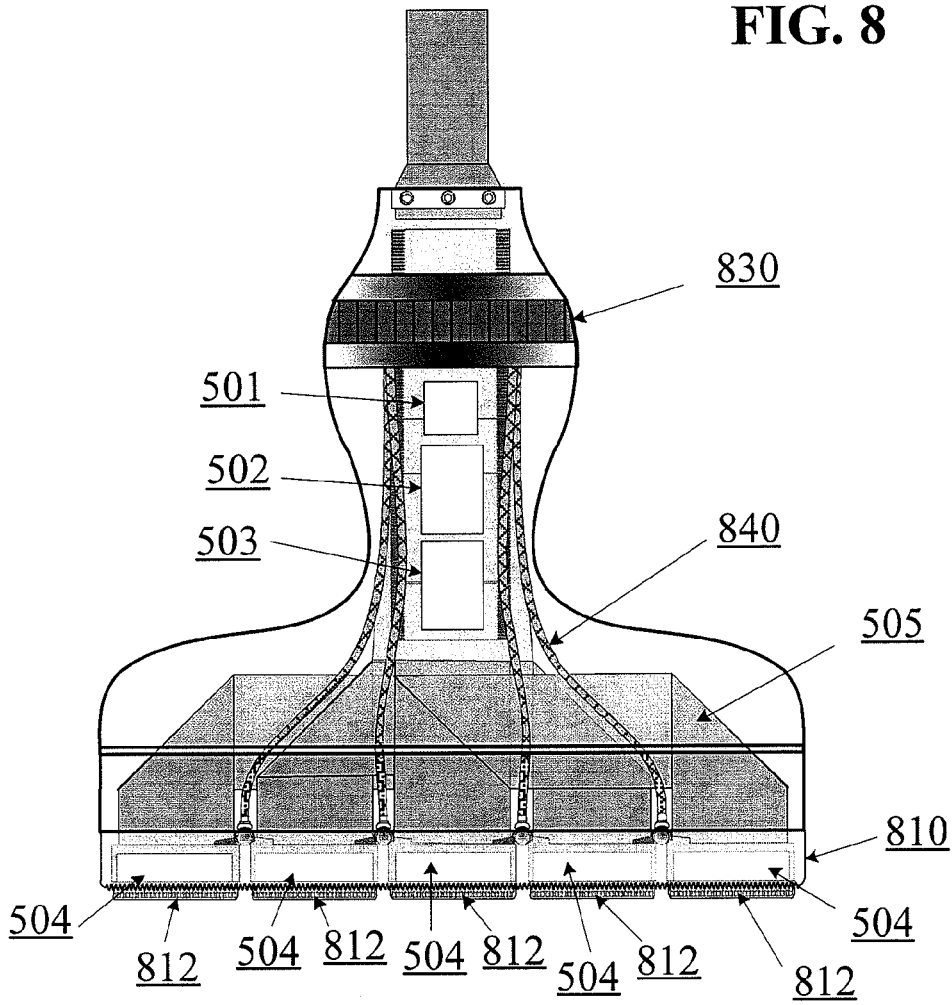
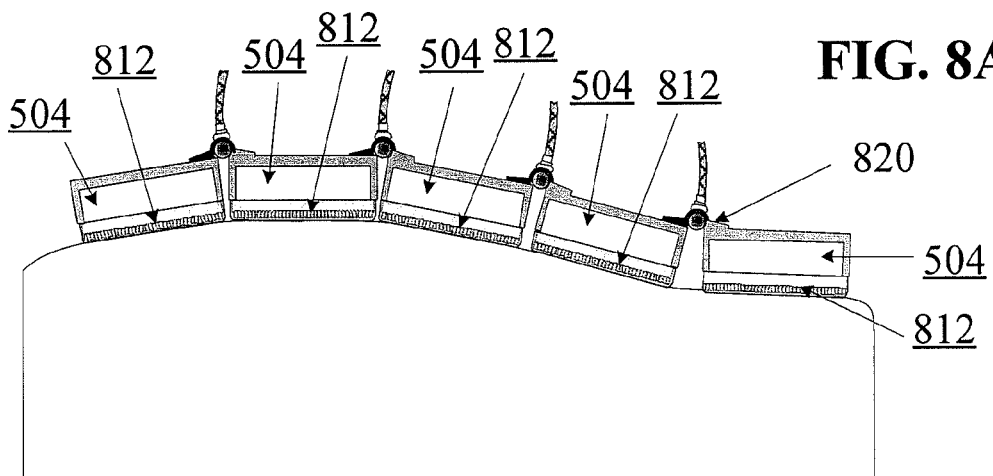

FIG. 8A



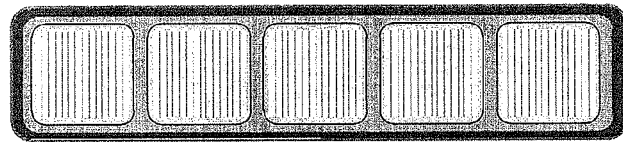
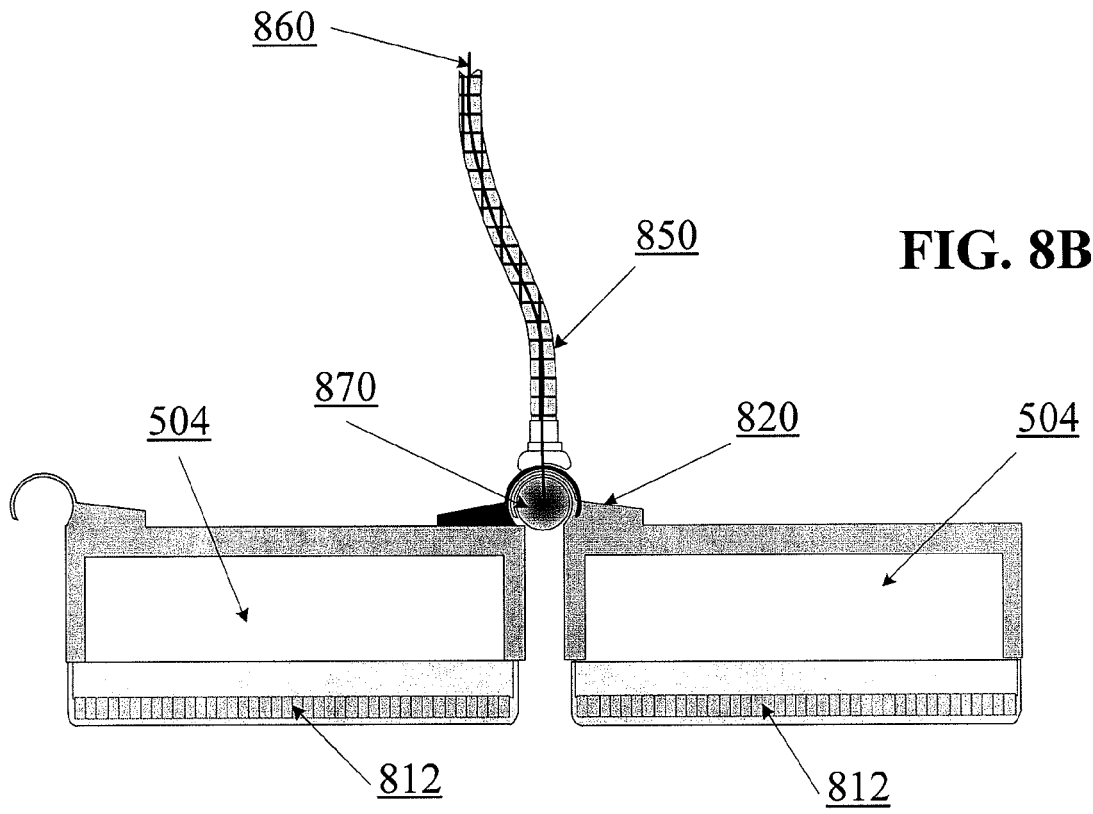

FIG. 8C

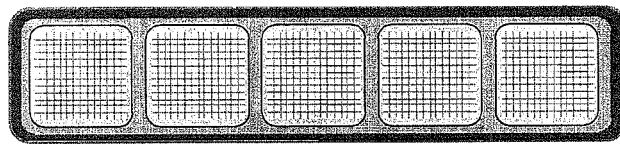

FIG. 8D

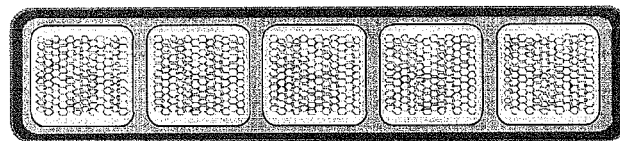

FIG. 8E

REFERENCES CITED IN THE DESCRIPTION

This list of references cited by the applicant is for the reader's convenience only. It does not form part of the European patent document. Even though great care has been taken in compiling the references, errors or omissions cannot be excluded and the EPO disclaims all liability in this regard.

Patent documents cited in the description

- US 8007439 B [0007]
- US 20110201933 A [0007]
- US 5797845 A [0008]
- US 2005124883 A [0009]

Non-patent literature cited in the description

- **HARVEY FEIGENBAUM.** Echocardiography. Lippincott Williams & Wilkins, 1993 [0003]
- **P. N. T. WELLS.** Biomedical Ultrasonics. Academic Press, 1977 [0003]

专利名称(译)	凹面超声换能器和3D阵列		
公开(公告)号	EP2627257A2	公开(公告)日	2013-08-21
申请号	EP2011833340	申请日	2011-10-12
[标]申请(专利权)人(译)	茂伊成像股份有限公司		
申请(专利权)人(译)	MAUI IMAGING , INC.		
当前申请(专利权)人(译)	MAUI IMAGING , INC.		
[标]发明人	SMITH DAVID M SPECHT DONALD F CABRERA LINDA V BREWER KENNETH D SPECHT DAVID J		
发明人	SMITH, DAVID, M. SPECHT, DONALD, F. CABRERA, LINDA, V. BREWER, KENNETH, D. SPECHT, DAVID, J.		
IPC分类号	A61B8/00 G01N29/24 G01S7/52 G01S15/89		
CPC分类号	A61B8/14 A61B8/4483 B06B1/0622 G01S7/5205 G01S7/52084 G01S15/8913 G01S15/892 G01S15/8927 G01S15/8929 G01S15/8934 A61B8/145 A61B8/4444 A61B8/4494 A61B8/461 A61B8/467 A61B8/5207 A61B8/523 A61B8/58		
优先权	61/392896 2010-10-13 US		
其他公开文献	EP2627257A4 EP2627257B1		
外部链接	Espacenet		

摘要(译)

多孔径超声成像 (MAUI) 探针或换能器独特地能够从超声阵列的单独孔径同时成像感兴趣区域。一些实施例提供用于设计, 构建和使用具有连续超声换能器阵列的超声探头的系统和方法, 所述超声换能器阵列可具有二维或三维的基本上连续的凹形弯曲形状 (即, 相对于待成像的物体凹入)。本文的其他实施例提供用于设计, 构建和使用具有其他独特配置的超声成像探针的系统和方法, 例如可调节探针和具有可变配置的探针。