



(51) International Patent Classification:
A61B 8/00 (2006.01)

(21) International Application Number:
PCT/US2013/045999

(22) International Filing Date:
14 June 2013 (14.06.2013)

(25) Filing Language: English

(26) Publication Language: English

(30) Priority Data:
61/660,201 15 June 2012 (15.06.2012) US

(71) Applicant: C.R. BARD, INC. [US/US]; 730 Central Avenue, Murray Hill, NJ 07974 (US).

(72) Inventors: COHEN, Benjamin, A.; 2170 Minton Drive, Phoenix, AZ 85202 (US). COX, Jeremy, B.; 685 Eighth Avenue, Salt Lake City, UT 84103 (US). SOUTHARD, Jeanette, E.; 120 Paradise Road, Park City, UT 84098 (US). MESSERLY, Shayne; 172 East 650 South, Kaysville, UT 84037 (US). MUSE, Jay, A.; 1555 Pony Express Way, Centerville, UT 84014 (US). STINGER, Kevin, W.; 963 Mary Margret Drive, Kaysville, UT 84037 (US).

(74) Agent: WIGHT, Todd, W.; Rutan & Tucker LLP, 611 Anton Boulevard, Suite 1400, Costa Mesa, CA 92626 (US).

(81) Designated States (unless otherwise indicated, for every kind of national protection available): AE, AG, AL, AM, AO, AT, AU, AZ, BA, BB, BG, BH, BN, BR, BW, BY, BZ, CA, CH, CL, CN, CO, CR, CU, CZ, DE, DK, DM, DO, DZ, EC, EE, EG, ES, FI, GB, GD, GE, GH, GM, GT, HN, HR, HU, ID, IL, IN, IS, JP, KE, KG, KN, KP, KR, KZ, LA, LC, LK, LR, LS, LT, LU, LY, MA, MD, ME, MG, MK, MN, MW, MX, MY, MZ, NA, NG, NI, NO, NZ, OM, PA, PE, PG, PH, PL, PT, QA, RO, RS, RU, RW, SC, SD, SE, SG, SK, SL, SM, ST, SV, SY, TH, TJ, TM, TN, TR, TT, TZ, UA, UG, US, UZ, VC, VN, ZA, ZM, ZW.

(84) Designated States (unless otherwise indicated, for every kind of regional protection available): ARIPO (BW, GH, GM, KE, LR, LS, MW, MZ, NA, RW, SD, SL, SZ, TZ, UG, ZM, ZW), Eurasian (AM, AZ, BY, KG, KZ, RU, TJ, TM), European (AL, AT, BE, BG, CH, CY, CZ, DE, DK, EE, ES, FI, FR, GB, GR, HR, HU, IE, IS, IT, LT, LU, LV, MC, MK, MT, NL, NO, PL, PT, RO, RS, SE, SI, SK, SM, TR), OAPI (BF, BJ, CF, CG, CI, CM, GA, GN, GQ, GW, KM, ML, MR, NE, SN, TD, TG).

[Continued on next page]

(54) Title: APPARATUS AND METHODS FOR DETECTION OF A REMOVABLE CAP ON AN ULTRASOUND PROBE

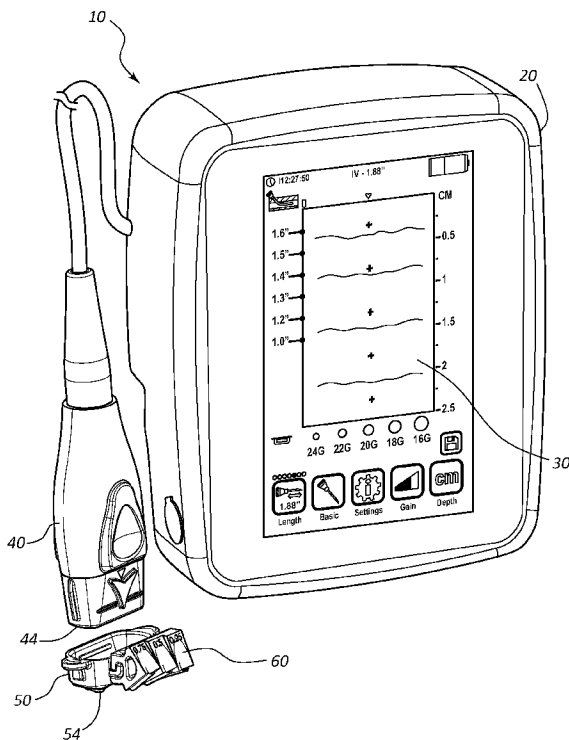

(57) Abstract: An ultrasound imaging device including the ability to determine when a component, such as a removable probe cap, is attached to a portion of an ultrasound probe. Such a cap is employed in one embodiment to act as a spacer component to provide a stand-off for the probe head. Detection of probe cap attachment to the ultrasound probe enables the resultant ultrasound image to be adjusted automatically by the ultrasound imaging system. In one embodiment, an ultrasound imaging system comprises an ultrasound probe, a cap or other component that is attachable to the probe, and a component attachment detection system for detecting attachment of the component to the probe. Once the cap is detected, an aspect of an ultrasound image produced by the imaging system is modified, such as cropping the image to remove undesired portions of the cap, such as the spacer component.

WO 2013/188833 A2



Declarations under Rule 4.17:

— *of inventorship (Rule 4.17(iv))*

Published:

— *without international search report and to be republished upon receipt of that report (Rule 48.2(g))*

**APPARATUS AND METHODS FOR DETECTION OF A REMOVABLE CAP ON
AN ULTRASOUND PROBE**

CROSS-REFERENCE TO RELATED APPLICATIONS

[0001] This application claims the benefit of U.S. Provisional Patent Application No. 61/660,201, filed June 15, 2012, and titled “Apparatus and Methods for Detection of a Removable Cap on an Ultrasound Probe,” which is incorporated herein by reference in its entirety.

BRIEF SUMMARY

[0002] Briefly summarized, embodiments of the present invention are directed to an ultrasound imaging device that includes the ability to determine when a component, such as a removable probe cap, is attached to a portion of an ultrasound probe thereof. Such a cap can include a spacer component to provide a standoff for the probe head, which enables relatively shallow subcutaneous structures of the patient’s body to be suitably imaged. The spacer component of the probe cap is implemented in one embodiment as an acoustically transparent hydrogel insert that enables the cap to slide easily over the skin of a patient during ultrasound imaging procedures. The probe cap is configured to be removably attachable to the head portion of the probe so as to be disposed of after use, in one embodiment.

[0003] Detection of probe cap attachment to the ultrasound probe enables the resultant ultrasound image to be adjusted automatically by the ultrasound imaging system. In one embodiment, adjustment of the image includes removing from the image the portion thereof corresponding to the hydrogel probe cap. By so doing, the top of the ultrasound image displayed by the imaging device will correspond with the surface of the patient’s skin, thus facilitating relatively easy interpretation of the image by the clinician performing the imaging procedure.

[0004] In one embodiment, an ultrasound imaging system comprises an ultrasound probe, a cap or other component attachable to the probe, and a component attachment detection system for detecting attachment of the component to the probe. Once the cap is detected, an aspect of an ultrasound image produced by the imaging system is modified, including cropping of the image to remove undesired portions of the cap, such as the spacer component.

[0005] These and other features of embodiments of the present invention will become more fully apparent from the following description and appended claims, or may be learned by the practice of embodiments of the invention as set forth hereinafter.

BRIEF DESCRIPTION OF THE DRAWINGS

[0006] A more particular description of the present disclosure will be rendered by reference to specific embodiments thereof that are illustrated in the appended drawings. It is appreciated that these drawings depict only typical embodiments of the invention and are therefore not to be considered limiting of its scope. Example embodiments of the invention will be described and explained with additional specificity and detail through the use of the accompanying drawings in which:

[0007] FIG. 1 is a perspective view of an ultrasound imaging system according to one embodiment;

[0008] FIG. 2 is a block diagram depicting elements of the ultrasound imaging system of FIG. 1;

[0009] FIG. 3 is partial cross sectional side view showing use of the ultrasound probe of FIG. 1 in accessing a vessel with a needle;

[0010] FIGS. 4A and 4B show exploded views of the ultrasound probe of FIG. 1, including an attachable cap and hydrogel insert;

[0011] FIG. 5 is a cross sectional side view of a portion of the ultrasound probe and attachable cap of FIG. 1;

[0012] FIGS. 6A and 6B show ultrasound images taken by the ultrasound imaging system of FIG. 1 according to one embodiment;

[0013] FIG. 7 is a screenshot from the ultrasound imaging system of FIG. 1 according to one embodiment;

[0014] FIG. 8 is a screenshot from the ultrasound imaging system of FIG. 1 according to one embodiment;

[0015] FIG. 9 is an ultrasound image showing sampling zones according to one embodiment;

[0016] FIG. 10 is a table showing aspects of a method for detecting the attachable cap of the ultrasound imaging system of FIG. 1 according to one embodiment;

[0017] FIGS. 11A and 11B are various views of an ultrasound probe and hydrogel insert according to one embodiment;

[0018] FIG. 12 is a simplified side view of an ultrasound probe and imaged portion of body tissue in accordance with one embodiment;

[0019] FIG. 13 is a simplified side view of an ultrasound probe and attachable cap according to one embodiment;

[0020] FIG. 14 is a simplified side view of an ultrasound probe and attachable cap according to one embodiment;

[0021] FIG. 15 is a simplified side view of an ultrasound probe and attachable cap according to one embodiment;

[0022] FIG. 16 is a simplified side view of an ultrasound probe and attachable cap according to one embodiment;

[0023] FIG. 17 is an ultrasound image showing sampling zones according to one embodiment;

[0024] FIG. 18 shows various stages of a method for detecting attachment of a spacer component to an ultrasound probe according to one embodiment;

[0025] FIG. 19 is a perspective view of an ultrasound probe according to one embodiment;

[0026] FIG. 20 shows elements of a cap detection system according to one embodiment;

[0027] FIG. 21 shows elements of a cap detection system according to one embodiment;
and

[0028] FIG. 22 shows elements of a cap detection system according to one embodiment.

DETAILED DESCRIPTION OF SELECTED EMBODIMENTS

[0029] Reference will now be made to figures wherein like structures will be provided with like reference designations. It is understood that the drawings are diagrammatic and schematic representations of exemplary embodiments of the present invention, and are neither limiting nor necessarily drawn to scale.

[0030] For clarity it is to be understood that the word “proximal” refers to a direction relatively closer to a clinician using the device to be described herein, while the word “distal” refers to a direction relatively further from the clinician. For example, the end of a catheter placed within the body of a patient is considered a distal end of the catheter, while the catheter end remaining outside the body is a proximal end of the catheter. Also, the words “including,” “has,” and “having,” as used herein, including the claims, shall have the same meaning as the word “comprising.”

[0031] Embodiments of the present invention are generally directed to an ultrasound imaging device including an ultrasound probe for ultrasonically imaging subcutaneous tissues of a body of a patient. More particularly, apparatus and methods are disclosed for determining when a component, such as a removable probe cap, is attached to a portion of an ultrasound probe. Such a cap is employed in one embodiment to act as a spacer component to provide a standoff for the probe head, which enables relatively shallow subcutaneous structures of the patient’s body to be suitably imaged. The spacer component of the probe cap is implemented in one embodiment as an acoustically transparent hydrogel insert that enables the cap to slide easily over the skin of a patient during ultrasound imaging procedures. The probe cap is configured to be removably attachable to the head portion of the probe so as to be disposed of after use, in one embodiment.

[0032] Detection of probe cap attachment to the ultrasound probe enables the resultant ultrasound image to be adjusted automatically by the ultrasound imaging system. In one embodiment, adjustment of the image includes removing from the image the portion thereof corresponding to the hydrogel probe cap. By so doing, the top of the ultrasound image displayed by the imaging device will correspond with the surface of the patient’s skin, thus facilitating relatively easy interpretation of the image by the clinician performing the imaging procedure.

[0033] FIG. 1 shows various components of an ultrasound imaging system (“system”) 10, according to one embodiment. As shown, the system 10 includes a console 20 housing various electronic and other components necessary for processing and depicting ultrasonic images. The console 20 includes a touchscreen display 30 for depicting ultrasonic images and for enabling touch-based input by a clinician to control the device and its functionality. A probe 40, containing one or more transducer elements in a head 44 thereof for emitting and receiving ultrasonic signals, is operably attached to the console 20 via a cable or other suitable interface.

[0034] An optional probe cap (“cap”) 50 is shown for removable attachment to the head 44 of the probe 40 so as to cover the transducer elements disposed therein. The cap 50 in one embodiment includes a hydrogel insert 54 or other suitable ultrasonically transparent material, such as silicone, for providing an ultrasonically transparent interface between the probe head 44 and the skin surface. The hydrogel insert 54 also acts as a spacer component to provide a standoff distance between the surface of the probe head 44 and the surface of the patient’s skin. Optionally, a needle guide 60 is slidably attached to the cap 50 to assist with guiding needles through the patient’s skin and into the vessel being imaged by the system 10. Further details regarding the probe cap, hydrogel insert, and needle guide can be found in: U.S. Patent Application Nos. 13/206,396, filed August 9, 2011, and entitled “Support and Cover Structures for an Ultrasound Probe Head;” 13/531,406, filed June 22, 2012, and entitled “Needle Guide with Selectable Aspects;” and 13/671,382, filed November 7, 2012, and entitled “Ruggedized Ultrasound Hydrogel Insert.” Each of the foregoing applications is incorporated herein by reference in its entirety. Note that other ultrasound imaging devices and systems that differ from that shown here can also benefit from the embodiments described herein.

[0035] FIG. 2 shows a block diagram of the system 10 of FIG. 1, according to one embodiment. In detail, the console 20, display 30, and probe 40 are represented, as in FIG. 1. The console 20 includes therein a motherboard 64 for governing system functionality and includes a processor or other general or special purpose computer, memory, storage locations, and other components for system operation. A power button 66 is included, as are USB ports 68 for interfacing with other devices. An external power supply 70, as well as a battery 72 and speaker 74, are provided for operation. The display 30 in the present embodiment includes an LCD screen 78 or other suitable screen, and a touchscreen 80 to enable touch-

based functionality via the display 30. Note that the system 10 can include different, fewer, or more components than those listed here, including those components that enable the system to operate in a networked manner with other local or remote computing or network systems.

[0036] FIG. 3 shows use of the system 10 in accessing a vessel 86 with a needle 84 in preparation for inserting a catheter into the vessel, according to one embodiment. The probe 40, equipped with the head-covering cap 50 and attached needle guide 60, is placed against the skin so as to ultrasonically image a slice of internal body tissue of the patient below the surface of the skin 82. As shown, a target location 88 of the vessel 86 imaged by the probe 40 is disposed a substantially vertical depth “x” below the end of the probe, corresponding to the skin surface 82. An image of the body tissue including the target location 88 is depicted as an ultrasound image on the display 30 of the imaging system 10. Though shown here as a central portion of the vessel 86, the target location 88 can be any one of various subcutaneous locations within the body.

[0037] The needle 84, disposed in the needle guide 60, follows an angled catheter insertion path a distance “y” to intercept the target location 88. This catheter insertion path, initially defined by the needle 84, is the same path to be subsequently followed by the catheter in order to gain access to and enter into the vessel 86. The vertical depth x from probe head 44 to the target location 88 can be calculated by a processor or other suitable component of the motherboard 64 of the system 10. Further, the system 10 can be loaded with appropriate data to know the distance y of the catheter insertion path to reach a given target location 88 at a depth x. In the present embodiment, these data are known by virtue of the position of the needle guide with respect to the probe head 44 and the angles in which the needle 84 can be oriented in the needle guide 60 in order to enable the needle to intercept the target location 88. As mentioned, such data can be loaded into the system memory for use by the processor during ultrasonic imaging, as will be described. In another embodiment, the system computes the distance y in real time based on the vertical depth x and other relevant factors.

[0038] FIGS. 4A and 4B depict further details of the probe 40 and probe cap 50 of the imaging system 10, according to one embodiment. In detail, the removable cap 50 is shown in position for attachment to the probe 40 so as to substantially cover the probe head 44. The cap 50 is secured to the probe 40 via a snap-fit arrangement in the present embodiment.

FIGS. 4A and 4B show in greater detail the hydrogel insert 54 that provides both a physical stand-off distance between the patient's skin and a head surface 44A of the probe head 44 as well as a lubricious surface to enable smooth movement of the probe 40 over the skin without further need of lubricating substances. Note that the probe cap can be attached and secured to the probe head by any one of many attachment/securement schemes. Note further that the particular size, shape, and configuration of the probe, probe cap, and hydrogel insert can vary from what is explicitly shown and described herein. In yet another embodiment a separate acoustic standoff is interposed between the ultrasound probe head and the patient's skin. The principles of the present disclosure can therefore be applied to this and other acoustic standoff scenarios.

[0039] FIG. 5 depicts the positional relationship between the probe head surface 44A and the hydrogel insert 54 when the cap 50 is attached to the probe 40 in the manner shown in FIG. 3. In particular, the cap 50 includes a body 90 that defines a cavity 92 into which the probe head 44 is received when the cap is removably mated with the probe 40. Note that a standoff distance 94 exists between the probe head surface 44A and the distal end of the hydrogel insert 54. So configured, the hydrogel insert 54 acts as a spacer component between the head surface 44A and the skin of the patient.

[0040] FIGS. 6A and 6B show an ultrasound image 96 produced by the imaging system 10. FIG. 6A shows the image 96 when no cap is attached to the probe 40. In contrast, FIG. 6B shows the image 96 when the cap 50 is attached to the probe 40, as shown in FIG. 5. Because of its standoff distance 94 (FIG. 5), the hydrogel insert 54 of the cap 50 is shown in the image 96, as indicated at 98. The patient's skin surface is also seen at 82. In one embodiment, it is desirable to remove this portion so as to provide an ultrasound image whose top corresponds with the skin surface 82 and not the standoff region 98.

[0041] In accordance with one embodiment, a cap detection system ("detection system") is disclosed to enable the imaging system 10 (FIG. 1) to automatically determine whether a cap, such as the probe cap 50 or other component, has been attached to the probe 40. If so, the imaging system can adjust the ultrasound image it produces to desirably remove the standoff region 98 (FIG. 6B) from the image.

[0042] In particular, in one embodiment the imaging system 10 can be configured such that full functionality of the imaging system is dependent on the cap 50 being attached to the

probe 40. For instance, in the present embodiment and as depicted in FIG. 7, a notification can be presented to alert the user to attach the cap 50 to the probe 40 to enable imaging system functionality. FIG. 7 shows a sample depiction 100 of the display 30 of the imaging system 10. The depiction 100 includes an ultrasound image 102 produced by the probe 40, and a control button field 104. A pop-up window 106 is depicted atop the ultrasound image 102, prompting the user to attach the cap 50 to the probe 40. The pop-up window 106 remains on the display until the detection system detects that the cap 50 has been suitably attached to the probe 40, as depicted in FIG. 3. Once cap attachment is detected by the detection system, the pop-up window 106 is removed and the depiction 100 can include an indicator showing the cap 50 is suitably attached, such as a cap attachment indicator 108, shown in FIG. 8. Of course, other notifications and indicators than the pop-up window 106 and indicator 108, including audio alerts, lights, etc., can be employed. Use of the cap detection system to determine whether the cap 50 has been attached to the probe 40 enables the above functionality.

[0043] In other embodiments, functionality of the imaging system to image and display ultrasonic images is not dependent upon whether the cap or other component to be detected is attached to the probe. In yet other embodiments, imaging system functionality is affected in other ways according to whether the cap is attached, such as changing the orientation of the ultrasound image when the cap is detected as being attached. These and other variations are therefore contemplated.

[0044] Inspection of the screenshot depiction 100 of FIG. 8 will indicate that the ultrasound image 102 has been adjusted such that the top of the image substantially corresponds with the patient's skin. In other words, the portion of the image corresponding to the cap 50 and hydrogel insert 54 has been removed. As discussed above, in one embodiment it is desirable to remove this portion so as to provide the ultrasound image beginning at the surface of the patient's skin.

[0045] FIGS. 9 and 18 depict various details regarding a method 400 employed by a cap detection system for detecting attachment of the cap 50 to the probe 40 so as to cover the head 44 according to one embodiment. In the present embodiment the cap detection system employs various components of the imaging system, including a motherboard processor or other suitable component of the imaging system 10 (FIG. 2) and the probe 40 to execute an algorithm for automatic cap detection.

[0046] In the present embodiment, and with continuing reference to FIGS. 9 and 18, the above-mentioned algorithm performs the method 400 for detecting whether the cap 50 is suitably attached to the probe 40 by first, at stage 402, dividing a predetermined portion of an ultrasound image 112 into a plurality of sampling zones 114, here shown a series of horizontally extending virtual slices that are vertically stacked atop one another and descending a predetermined distance from the top of the image. The predetermined portion of the image 112 that is covered by the sampling zones corresponds in one embodiment to the expected zone in which the standoff region 98, *i.e.*, the portion of the image that includes the imaged cap 50 and hydrogel insert 54, is expected to be found. The predetermined portion may be pre-programmed into or may be dynamically determined by the system 10. In one embodiment, for example, the standoff distance 94 of the hydrogel insert (FIG 5) is about 3.9 mm, while the predetermined portion of the ultrasound image that will be covered by sampling zones is about 2.8 mm measured down from the top of the ultrasound image. An example number *n* of sampling zones 114 is shown in FIG. 9, descending down to and including a portion of the imaged skin surface 82. The number, size, etc. of the sampling zones can vary according to design, user input, etc., and can be dynamically or user-adjustable.

[0047] Another sampling zone configuration that can be employed is depicted in FIG. 17, showing the ultrasound image 112 including a plurality of sampling zones 114 as a series of vertically extending virtual slices that vertically extend downward from the top of the image and are horizontally stacked aside one another across the image to cover the expected or designated standoff region 98. In one embodiment, the number of sampling zones is 20, though other numbers of zones can be employed.

[0048] In stage 404, a threshold for image intensity is determined. The image intensity threshold determines the level at which the algorithm considers an ultrasonic signal to represent detected matter. Thus, for each sampling zone 114 an ultrasound signal detected by the probe 40 that includes an image intensity level exceeding the threshold indicates the presence ultrasonically detectable matter for that sampling zone, while those zones having image intensities below the threshold are considered to have no ultrasonically detectable material in them. As the hydrogel insert 54 that forms the standoff region 98 is ultrasonically transparent, sampling zones that include a sufficient portion of the insert will have image intensities below the determined threshold. Note that the image intensity threshold can be

pre-programmed into the imaging system 10, user-adjustable, or dynamically determined by the imaging system. In one embodiment, the image intensity can numerically vary between about 0 (low image intensity) and about 255 (high image intensity), and the image intensity threshold is about 5. In another embodiment, the image intensity threshold is about 20. These values, of course, can vary in other embodiments.

[0049] In stage 406, an average image intensity for each sampling zone 114 is then measured by the system 10 on the same intensity scale given above. In stage 408, the average image intensities for the sampling zones 114 are then evaluated to determine whether a sufficient number of sampling zones have image intensities equal to or below the threshold image intensity discussed above. Table 120 in FIG. 10 shows the collection of such data by the imaging system 10 in one embodiment. If a sufficient number of sampling zones have image intensities equal to or below the threshold value, it is determined by the system 10 that the standoff region 98 is being detected and thus the probe cap 50 is suitably attached to the probe 40. If an insufficient number of sampling zones have image intensities equal to or below the threshold image intensity, the system 10 determines that no cap is attached to the probe 40.

[0050] The number of sampling zones 114 that must have image intensities equal to or below the threshold image intensity can be pre-programmed into the imaging system 10, user-adjustable, or dynamically determined by the imaging system. In one embodiment, if at least 19 sampling zones 114 are found to have image intensities equal to or below the threshold image intensity, the system 10 can determine that the cap 50 is attached to the probe 40. Correspondingly, if less than two sampling zones 114 are found to have to have image intensities equal to or below the threshold image intensity, the system 10 can determine that the cap 50 is not attached to the probe 40. These numbers can vary in other embodiments.

[0051] The above process is iterated by the system 10 for each imaging cycle during ultrasound imaging such that evaluations for the presence of the probe cap are repeatedly performed during system operation. Each imaging cycle produces a corresponding ultrasound image, or frame, and multiple frames per second can be produced by the system 10, in one embodiment. In another embodiment, the above process can be iterated at a regular or user-defined interval, if desired.

[0052] In one embodiment, a certain number of consecutive ultrasound images frames having a suitable number of sampling zones 114 that are equal to or below the threshold image intensity must be encountered for the system 10 to determine that the cap 50 is attached to the probe 40. For instance, in the present embodiment, at least five ultrasound image frames in a row that are sequentially produced by the system 10 must each have a suitable number of sampling zones 114 that are equal to or below the threshold image intensity for the system 10 to determine that the cap 50 is attached to the probe 40, though this number can vary.

[0053] For example, and in light of the above, the system 10 in one embodiment will determine that the cap 50 is suitably attached to the probe 40 if, for five consecutive ultrasound image frames, more than 18 sampling zones 114 are found to have image intensities equal to or below the threshold image intensity. Correspondingly, the system 10 will determine that the cap 50 is not suitably attached to the probe 40 if, for five consecutive ultrasound image frames, less than two sampling zones 114 are found to have to have image intensities equal to or below the threshold image intensity. Once the cap attachment status is set by the system 10 as just described, it will not change unless the above more-than-18 or less-than-two sampling zone conditions are met for five consecutive ultrasound image frames. Should the number of qualifying sampling zones fall within 2-18 for a given ultrasound image frame, the cap attachment status is not changed from its previous setting and the counter for determining five consecutive image frames is reset.

[0054] Once it determines that the cap 50 is suitably attached to the probe 40 as described above, the system 10 adjusts the image 112 to crop or remove the region determined to correspond to the standoff region 98 representing the hydrogel insert 54. This results in a view similar to the depiction 100 shown in FIG. 8 wherein the skin surface 82 is positioned proximate the top of the ultrasound image 102.

[0055] As mentioned above, during iterative execution of the above process the system 10 can determine that the cap 50 has been removed from or is not currently attached to the probe 40. Once the system 10 determines that the cap 50 is not suitably attached to the probe 40, the cropping of the image described above is not performed, and the full ultrasound image is depicted.

[0056] In addition to ultrasound image cropping, it is appreciated that other/additional actions can be taken by the system 10 once the cap 50 is determined either to be attached or detached from the probe 40. For instance, in one embodiment, the orientation of the ultrasound image can be flipped and image characteristics such as grayscale can be modified when the cap is detected as suitably attached. FIG. 19 shows one example of a probe 440 that can utilize such functionality. As shown, the probe 440 includes a head portion 444 and a fixture 462 for receiving thereon a detachable needle guide. The fixture 462 can be adapted to receive thereon needle guides such as those disclosed in U.S. Patent No. 5,235,987, entitled "Needle Guide," and U.S. Patent Application No. 12/642,456, filed December 18, 2009, and entitled "Needle Guides for a Sonographic Imaging Device." Each of the aforementioned documents is incorporated herein by reference in its entirety.

[0057] Note that in addition to the above-described, other algorithms can be executed by the system 10 to determine attachment of the cap to the probe. One possible algorithm employs a Hough transform to identify and locate the interface between the skin surface and the hydrogel insert in the ultrasound image in a predetermined or programmed area of the image. If the interface is detected with sufficient certainty, the system 10 can determine that the cap is suitably attached to the probe.

[0058] FIGS. 11A and 11B depict details of a cap detection system according to another embodiment, wherein a probe 140 including a head 144 in which a transducer 160 of multiple transducer elements 160A is disposed. A hydrogel insert 154 is shown as operably positioned proximate the probe head 144 such that ultrasonic signals from the transducer 160 can pass through the hydrogel insert 154 to and from the body tissue. In the present embodiment, the hydrogel insert 154 acts as a spacer component and is included in a cap that is removably attachable to the probe 140.

[0059] As shown in FIG. 11B, one or more ultrasonically reflective markers 156 can be included in the hydrogel insert 154 in one or more detection regions 162 of the insert. In the present embodiment, two detection regions 162 are longitudinally defined in the hydrogel insert 154 and extend in the direction of travel of ultrasonic signals emitted from the probe head transducer 160. The system 10 is configured to detect the reflective marker(s) 156 when the hydrogel insert-including cap is suitably attached to the probe 140. Thus, if the reflective markers 156 are detected, the imaging system 10 can determine that the cap is suitably attached to the probe 140. No detection of the reflective markers 156 by the imaging system

10 indicates that no cap is attached. The number, types, position, and other configuration of the hydrogel insert and its reflective markers/detection regions can vary from what is explicitly shown and described herein.

[0060] FIG. 12 depicts details of a cap detection system according to another embodiment, wherein a probe 240 including a head 244 in which a plurality of transducer elements 260A is disposed. Note that, for clarity, only the end transducer elements 260A are shown in FIG. 12. A hydrogel insert 254 is shown as operably positioned proximate the probe head 244 such that ultrasonic signals from the transducer can pass through the hydrogel insert 254 to and from the body tissue. In the present embodiment, the hydrogel insert 154 acts as a spacer component and is included in a cap that is removably attachable to the probe 140.

[0061] As shown, one or more transducer elements – in this embodiment, the end transducer elements 260A – can be designated by the imaging system 10 to continuously emit ultrasound signals and monitor the reflected signals. Instead of being used for ultrasonic imaging of tissue, the end transducer elements 260A are used to monitor for the presence of the hydrogel insert, and thus cap attachment. Should no reflection be detected in the standoff region corresponding to the hydrogel insert 254, the system 10 determines that the cap including the hydrogel insert is suitably attached. Correspondingly, a relatively strong ultrasonic reflection within the expected standoff region indicates that no cap and hydrogel insert is present. The region to be monitored for the presence of ultrasonic reflections can be user-defined, dynamically defined, or pre-programmed into the imaging system 10.

[0062] In one embodiment, multiple transducer elements along the length of the transducer can be utilized to monitor for the hydrogel insert and associated cap, as just described, in contrast to using only the end transducers. For instance, a transducer element at or near the middle of the transducer can be employed, in addition to the end transducer elements. In another embodiment, the end transducer elements 260A are utilized to identify and locate the hydrogel-skin surface interface, i.e., a depth where a substantially acoustically transparent region transitions abruptly to an acoustically non-transparent region in a region of interest that is pre-programmed, dynamically determined by the system, input by a user, etc. If such an interface is encountered at a depth in accordance with expected values, the imaging system 10 can determine that the cap is suitably attached to the probe.

[0063] Note further that, in at least the present embodiment, the imaging system can dynamically determine the height of the hydrogel insert acting as a spacer component. In such cases, the imaging system can alter the ultrasound image once the cap has been detected as being attached to the probe so as to crop only that portion of the image corresponding to the determined height of the hydrogel insert. In other embodiments, a look-up table including the measure of image cropping distances can be stored and accessed by the system once the size of the hydrogel insert or other suitable spacer component has been determined so as to crop a desired portion of the ultrasound image.

[0064] FIG. 13 depicts details of a cap detection system according to another embodiment, wherein a probe 340 including a head 344 in which a transducer is disposed. A cap 350 including a hydrogel insert 354 that acts as a spacer component is shown as ready for attachment to the probe 340. A magnetic element, such as a permanent magnet 360, is included with the cap 350. A magnetic sensor 362, such as a Hall Effect sensor, is included with the probe 340 and is configured to detect the magnetic field of the magnet 360 when the cap 350 is attached to probe 340. Note that the type, size, position, and other configuration of the magnetic elements and magnetic sensor can vary from what is shown and described herein.

[0065] FIG. 14 depicts details of a cap detection system according to another embodiment, wherein an infrared or other electromagnetic wave-based transceiver 370 is included with the head 344 of the probe 340. An infrared or other suitable reflector 372 is optionally included on the cap 350 and positioned to reflect infrared signals produced by the transceiver 370 when the cap 350 is suitably attached to probe 340. Note that the type, size, position, and other configuration of the transceiver and reflector can vary from what is shown and described herein.

[0066] FIG. 15 depicts details of a cap detection system according to another embodiment, wherein a mechanical switch 380 is included on the probe such that it is depressed or otherwise actuated when the cap 350 is suitably attached to the probe. This will indicate to the imaging system 10 that the cap is suitably attached. The type, size, position, and other configurations of the switch can vary from what is shown and described here. For instance, in one embodiment an optical switch can be used to indicate when the cap is suitably attached to the probe.

[0067] FIG. 16 depicts details of a cap detection system according to another embodiment, wherein the cap 350 includes an RFID 390 chip that is detectable by a corresponding RFID reader 392 disposed in the head 344 or other portion of the probe 340 when the cap 350 is suitably attached to the probe. The RFID chip 390 can include one of various types, including active and passive chips, etc.

[0068] FIGS. 20-22 depict yet other cap detection systems according to other embodiments. In detail, FIG. 20 shows a cap detection system including light source/detector 470 capable of emitting and detecting light or other suitable form of electromagnetic radiation, and a retro reflector 472 configured to reflect light back in the direction of the light impinging upon it. The light source/detector 470 and retro reflector 472 can be respectively placed on the probe and cap in an offset configuration as shown in FIG. 20 to enable cap detection to occur only when both components are suitably positioned with respect to one another. If the light is not reflected back, then the cap is considered not attached.

[0069] FIG. 21 shows a cap detection system including light source/detector 480 capable of emitting and detecting light or other suitable form of electromagnetic radiation, and a phosphorous-coated element 482 that is configured to emit light at a particular wavelength and in a predetermined timeframe after the impingement of light from the light source/detector. In operation, light is emitted from the light source/detector 480 and impinges on phosphorous-coated element 482, both components being respectively positioned on the probe and the cap in a suitable configuration. The impinging light causes the phosphorous-coated element 482 to re-emit light of a particular wavelength, which can be detected by the light source/detector 480. Additionally, the re-emitted light can emit from the phosphorous-coated element 482 at a decay rate that can be detected by the light source/detector 480 and analyzed by the system 10 to determine that the cap is suitably attached. If the light re-emission and/or decay rate are not detected, then the cap is considered not attached.

[0070] FIG. 22 shows a cap detection system including light source/detector 490 capable of emitting and detecting light or other suitable form of electromagnetic radiation, and a polarizing reflector 492 configured to reflect back polarized light to the light source/detector. A polarizing filter 494 is interposed between the light source/detector 490 and the polarizing reflector 492 and can prevent transmission of light that has a polarization of 90 degrees from that of the filter. By properly orienting the reflector 492 and filter 494 with respect to each

other as respectively attached to the probe and cap (or via versa), the system 10 can determine whether the cap is suitably attached to the probe by analyzing the characteristics of the light detected by the light source/detector 490 after reflection by the reflector and passage through the filter. Note that in this and the other embodiments above, the light source/detector can be separate components, in one embodiment. Note also that the embodiments discussed above, including the discussion relating to FIGS. 20-22, can be useful for eliminating false positive detections of cap attachment and for preventing use of non-authorized components with the probe, in one embodiment.

[0071] In addition to the foregoing, other cap detection systems can be employed, including manual input to the imaging system 10 by a user after visually determining that the cap or other component is suitably attached to the probe, in one embodiment.

[0072] Embodiments described herein may comprise a special purpose or general-purpose computer including computer hardware, as discussed in greater detail below. Embodiments within the scope of the present disclosure also include computer-readable media for carrying or having computer-executable instructions or data structures stored thereon. Such computer-readable media can be any available media that can be accessed by a general purpose or special purpose computer. By way of example, and not limitation, computer-readable media can comprise physical (or recordable-type) computer-readable storage media, such as, RAM, ROM, EEPROM, CD-ROM or other optical disk storage, magnetic disk storage or other magnetic storage devices, or any other medium which can be used to store desired program code means in the form of computer-executable instructions or data structures and which can be accessed by a general purpose or special purpose computer.

[0073] A “network” is defined herein as one or more data links that enable the transport of electronic data between computer systems and/or modules. When information is transferred or provided over a network or another communications connection (either hardwired, wireless, or a combination of hardwired or wireless) to a computer, the computer properly views the connection as a computer-readable medium. Thus, by way of example, and not limitation, computer-readable media can also comprise a network or data links which can be used to carry or store desired program code means in the form of computer-executable instructions or data structures and which can be accessed by a general purpose or special purpose computer.

[0074] Computer-executable instructions comprise, for example, instructions and data which cause a general purpose computer, special purpose computer, or special purpose processing device to perform a certain function or group of functions. The computer executable instructions may be, for example, binaries, intermediate format instructions such as assembly language, or even source code. Although the subject matter has been described in language specific to structural features and/or methodological acts, it is to be understood that the subject matter defined in the appended claims is not necessarily limited to the described features or acts described above. Rather, the described features and acts are disclosed as example forms of implementing the claims.

[0075] Those skilled in the art will appreciate that the embodiments herein may be practiced in network computing environments with many types of computer system configurations, including, personal computers, desktop computers, laptop computers, message processors, hand-held or portable devices, multi-processor systems, microprocessor-based or programmable consumer electronics, network PCs, minicomputers, mainframe computers, mobile telephones and devices, PDAs, pagers, and the like. The embodiments may also be practiced in distributed system environments where local and remote computer systems, which are linked (either by hardwired data links, wireless data links, or by a combination of hardwired and wireless data links) through a network, both perform tasks. In a distributed system environment, program modules may be located in both local and remote memory storage devices.

[0076] Embodiments of the invention may be embodied in other specific forms without departing from the spirit of the present disclosure. The described embodiments are to be considered in all respects only as illustrative, not restrictive. The scope of the embodiments is, therefore, indicated by the appended claims rather than by the foregoing description. All changes that come within the meaning and range of equivalency of the claims are to be embraced within their scope.

What is claimed is:

CLAIMS

1. An ultrasound imaging system, comprising:
an ultrasound probe;
a component attachable to the probe; and
a component attachment detection system for detecting attachment of
the component to the probe,
wherein an aspect of an ultrasound image produced by the imaging
system is modified according to detection of component
attachment to the probe.
2. The system as defined in claim 1, wherein the component is removably
attachable to the probe.
3. The system as defined in claim 2, wherein the component includes a
cap that at least partially covers a head portion of the probe, the cap including a spacer
component that is interposed between the head portion and the skin of a patient during use of
the probe.
4. The system as defined in claim 3, wherein the component attachment
detection system uses a processor to detect image intensity levels of a plurality sampling
zones of an ultrasound image produced by the imaging system, the sampling zones disposed
in a region of the ultrasound image where the spacer component is expected to be located.
5. The system as defined in claim 4, wherein the attachment detection
system determines the cap is attached to the probe when a minimum number of sampling
zones include image intensity levels below a particular threshold level.
6. The system as defined in claim 3, wherein the spacer component of the
cap includes a hydrogel insert.
7. The system as defined in claim 6, wherein the component detection
system includes at least one reflective marker disposed in the hydrogel insert, the at least one
reflective marker detectable by at least one transducer element of a transducer array of the
probe.

8. The system as defined in claim 6, wherein the component detection system includes at least two transducer elements of a transducer array disposed in the head portion of the probe, the transducer elements used by the component detection system to detect a transition from an acoustically transparent region to an acoustically non-transparent region in a region of interest.

9. The system as defined in claim 6, wherein the component detection system includes a magnetic sensor included with the probe that detects a magnetic element included with the cap when the cap is attached to the probe.

10. The system as defined in claim 6, wherein the component detection system includes an infrared transceiver included with the probe that detects the cap via infrared reflection when the cap is attached to the probe.

11. The system as defined in claim 6, wherein the component detection system includes a mechanical switch included on the probe, the mechanical switch actuated when the cap is attached to the probe.

12. The system as defined in claim 6, wherein the component detection system includes a RFID reader included with the probe that detects an RFID chip included with the cap when the cap is attached to the probe.

13. The system as defined in claim 3, wherein the aspect of the ultrasound image that is modified according to detection of the cap attachment to the probe includes removal from the ultrasound image a portion thereof corresponding to the imaged spacer component, and wherein the component attachment detection system includes a light source, a light detector, and at least one of a retro reflector, a phosphorus element, and a polarizing reflector.

14. A method for detecting attachment of a substantially acoustically transparent spacer component to a probe of an ultrasound imaging device, the method comprising:

dividing an area of an ultrasound image produced by the imaging device into a plurality of sampling zones, the sampling zones corresponding to an area of the ultrasound image occupied by the spacer component when attached to the probe;
measuring an image intensity for each sampling zone; and
determining that the spacer component is attached to the probe when the intensities of a sufficient number of the sampling zones are less than or equal to a threshold image intensity.

15. The method as defined in claim 14, wherein dividing, calculating, and determining are performed on a single image frame produced by the imaging device.

16. The method as defined in claim 14, wherein the method is iteratively performed on each of consecutive image frames produced by the imaging device.

17. The method as defined in claim 14, wherein the spacer component is gel-based and is included with a cap that removably attaches to cover at least a portion of a head portion of the probe.

18. The method as defined in claim 14, wherein the method further comprises:

determining that the removable component is detached from the probe when the image intensities of a sufficient number of the sampling zones exceed the threshold image intensity.

19. The method as defined in claim 14, further comprising:
after determining the cap is attached to the probe, altering the ultrasound image.

20. The method as defined in claim 19, wherein altering the ultrasound image includes removing a portion of the image corresponding to the spacer component such that an imaged skin surface of the patient is proximate the top of the ultrasound image.

21. The method as defined in claim 14, wherein a shape of the sampling zones is one of a virtual slice horizontally extending across the ultrasound image and a virtual slice vertically extending down from a top portion of the ultrasound image.

22. The method as defined in claim 14, wherein each of at least five successive ultrasound images produced by the ultrasound imaging device must include a sufficient number of sampling zones that are less than or equal to the threshold image intensity to determine that the spacer component is attached to the probe.

23. A method for using an ultrasound imaging system, the system including an ultrasound probe, a display for depicting ultrasound images produced by the probe, and a cap that is attachable to the probe, the method comprising:

by a cap attachment detection system of the ultrasound imaging system, detecting whether the cap is attached to the ultrasound probe; and

when the cap is detected as attached to the ultrasound probe, altering an image produced by the ultrasound imaging system in a predetermined manner.

24. The method as defined in claim 23, wherein altering the image includes changing the orientation of the image from a first image orientation corresponding to no attachment of the cap to a second image orientation when the cap is detected as attached to the probe.

25. The method as defined in claim 24, further comprising cropping a first portion of the ultrasound image and adjusting a grayscale or other image characteristic of the ultrasound image when the ultrasound image is oriented in the second image orientation.

26. The method as defined in claim 23, wherein the cap includes a hydrogel-based spacer component that separates a head portion of the probe from a skin surface of a patient, and wherein altering the image includes cropping a portion of the image corresponding to imaging of the spacer component.

27. The method as defined in claim 23, wherein the cap attaches to the probe so as to cover a head portion of the probe, and wherein the method further comprises:

when the cap is not attached to the ultrasound probe, a message is conveyed to a user of the ultrasound imaging system.

28. The method as defined in claim 27, wherein the message includes a popup window depicted on the display.

29. The method as defined in claim 23, wherein the method is implemented by a processor executing computer executable instructions, and wherein uninhibited use of the ultrasound imaging system is enabled after the cap is detected as being attached to the probe.

30. The method as defined in claim 23, wherein the method is implemented by a processor executing a Hough transform algorithm.

31. The method as defined in claim 23, wherein the component attachment detection system includes a light source, a light detector, and at least one of a retro reflector, a phosphorus element, and a polarizing reflector.

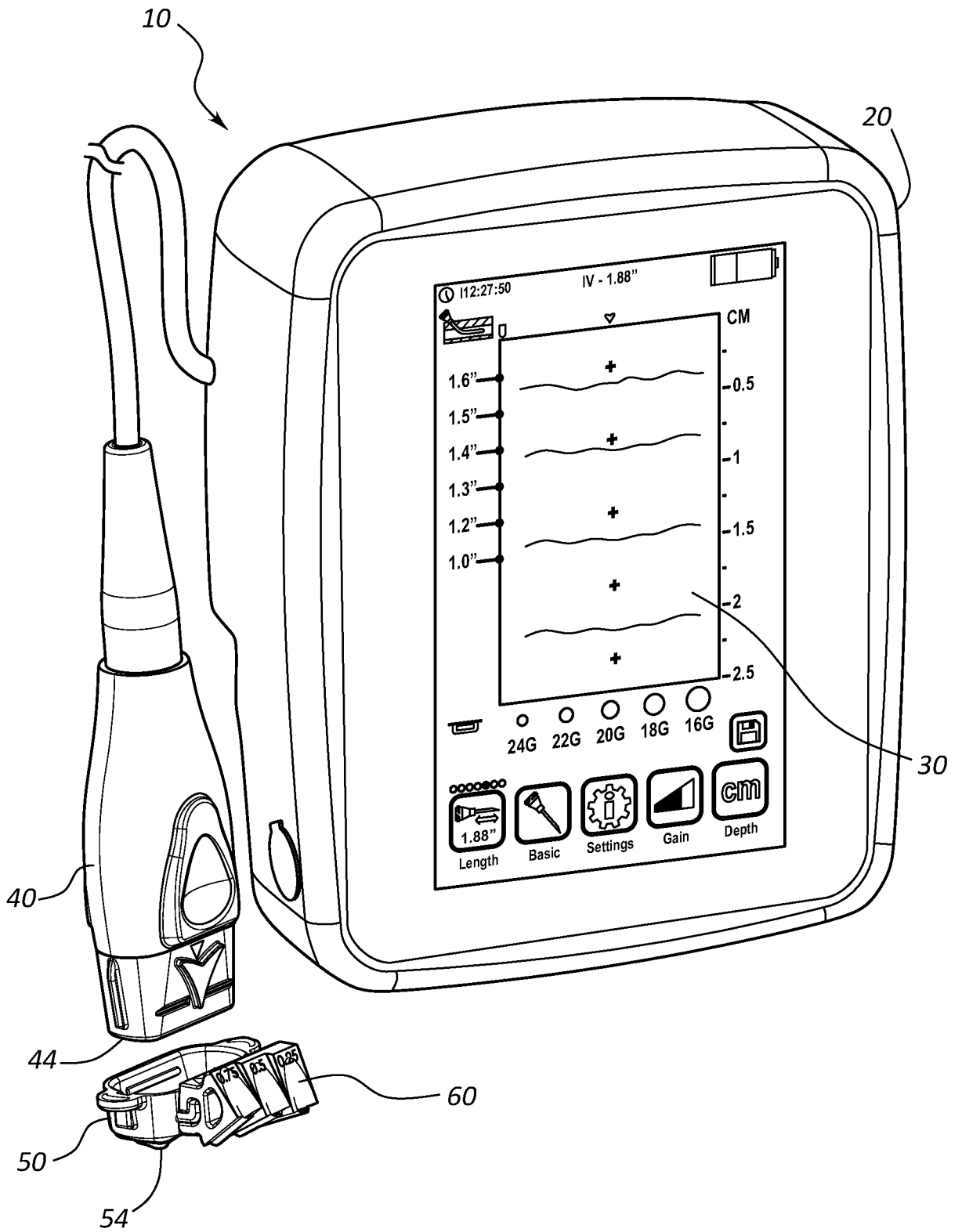

FIG. 1

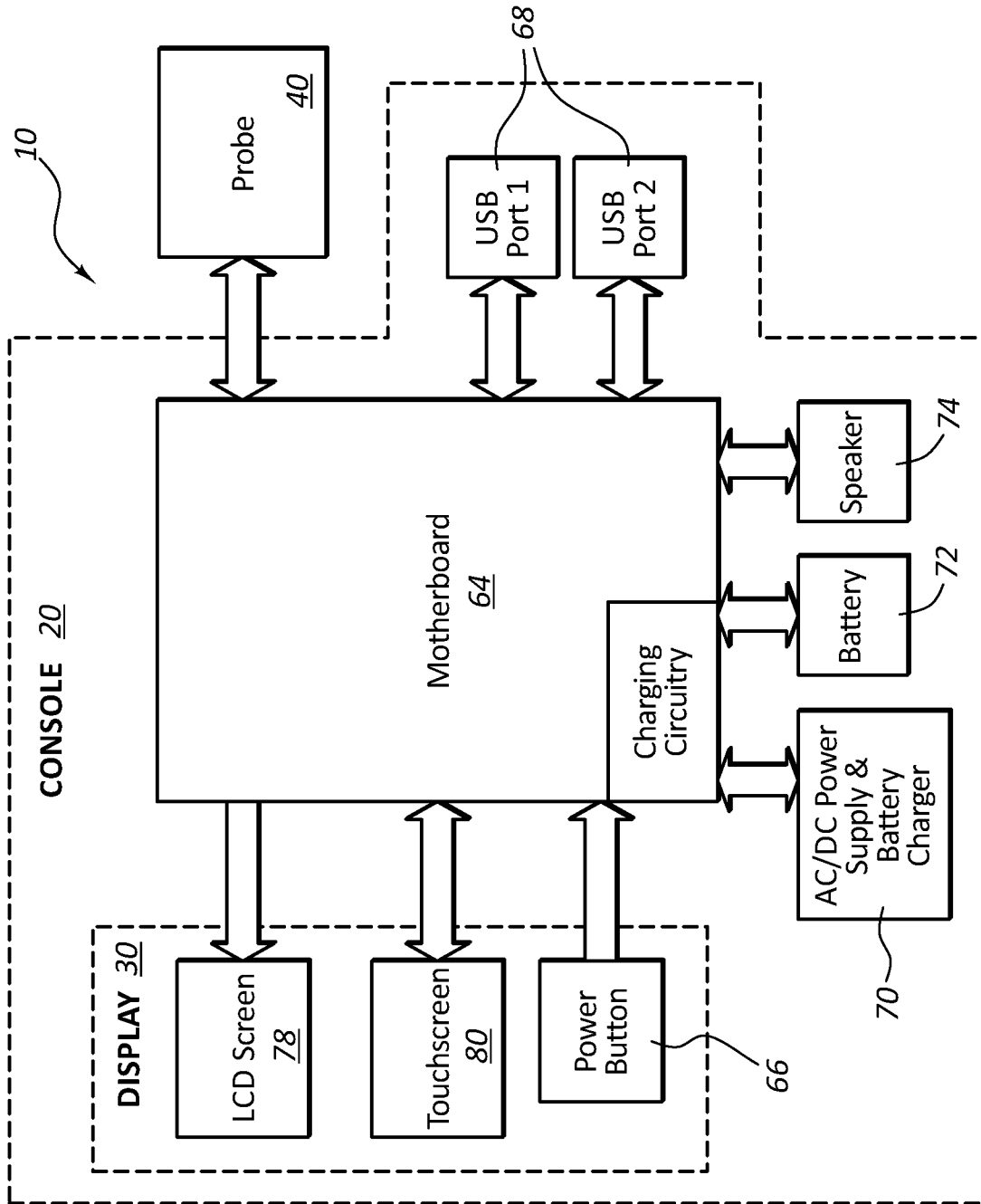

FIG. 2

3/18

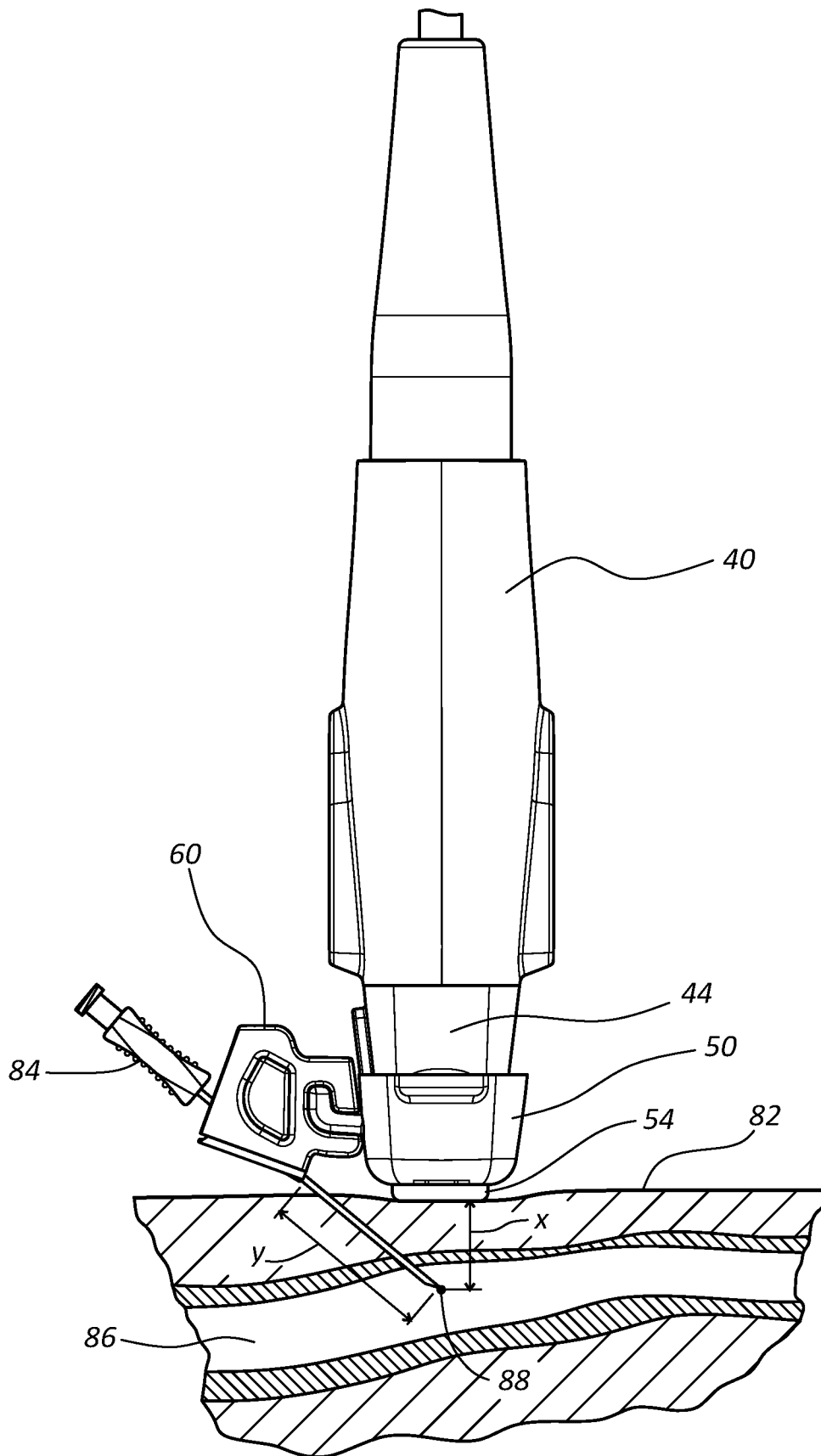

FIG. 3

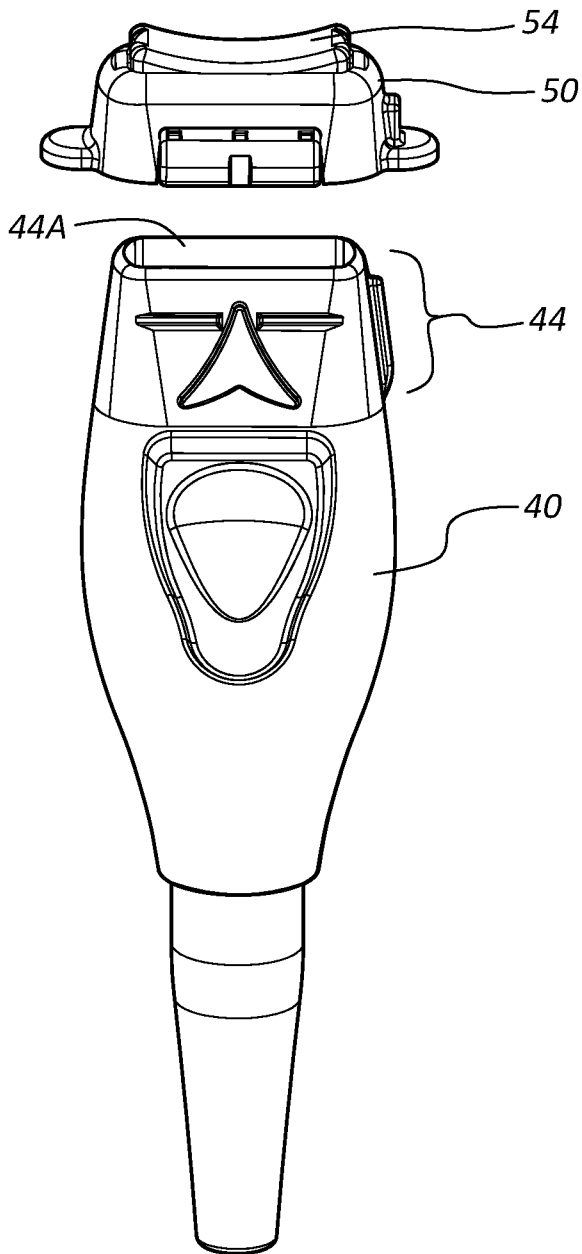

FIG. 4A

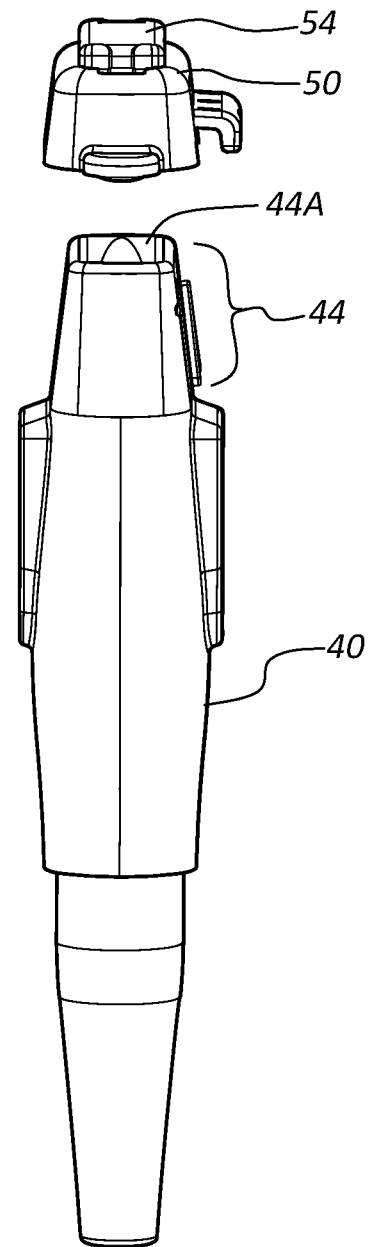

FIG. 4B

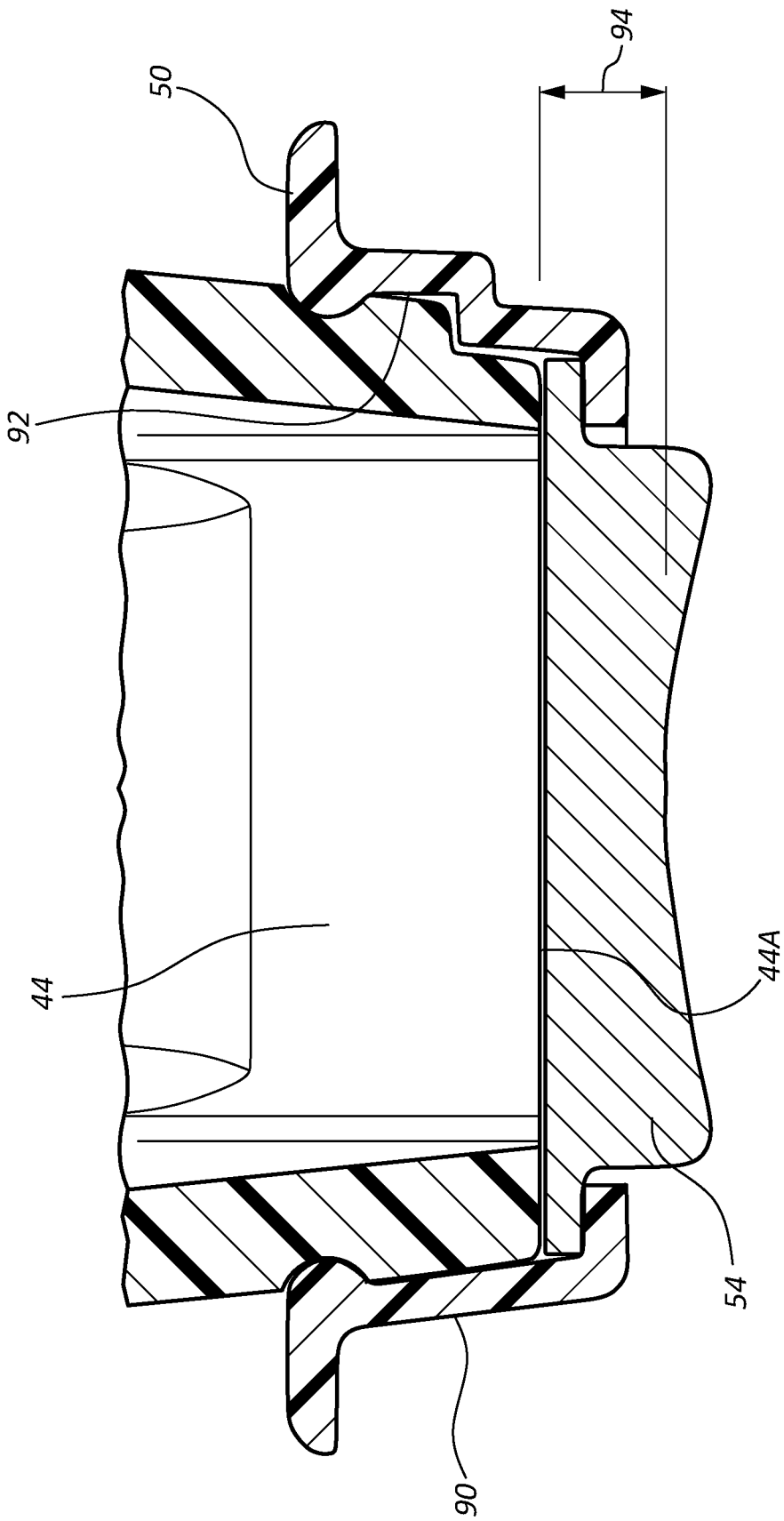

FIG. 5

6/18

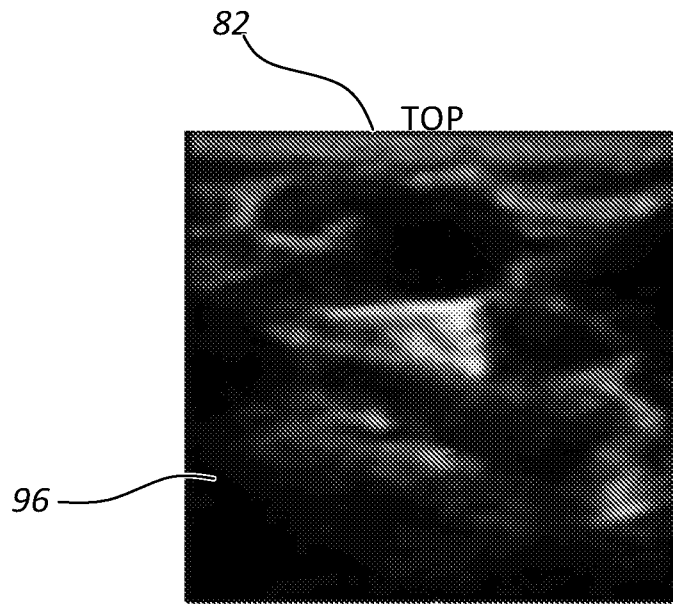

FIG. 6A

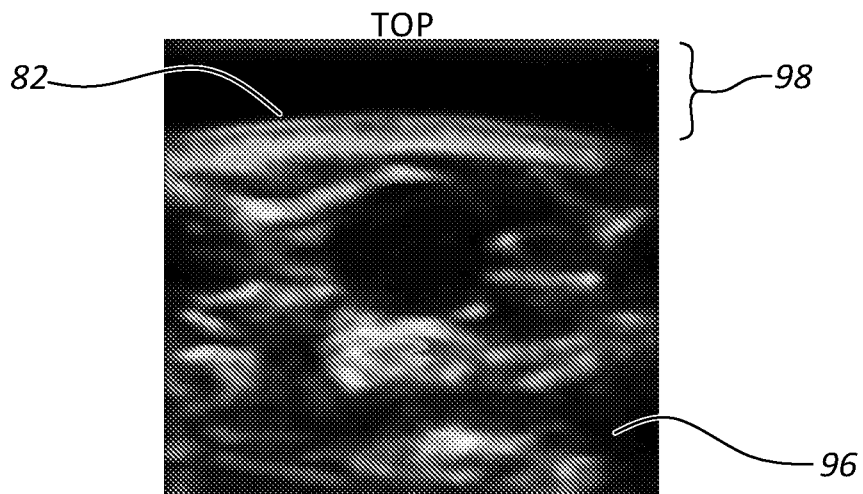

FIG. 6B

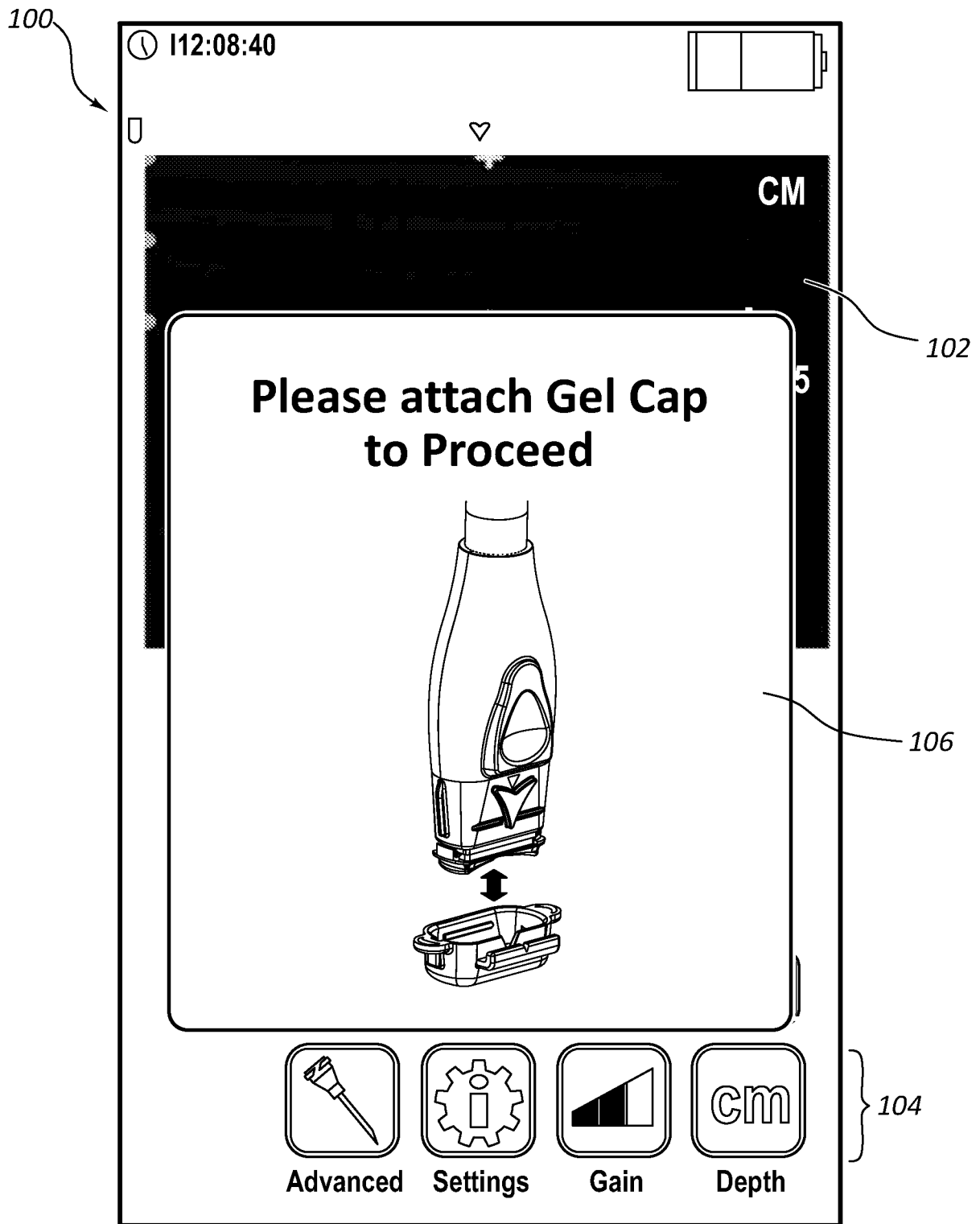

FIG. 7

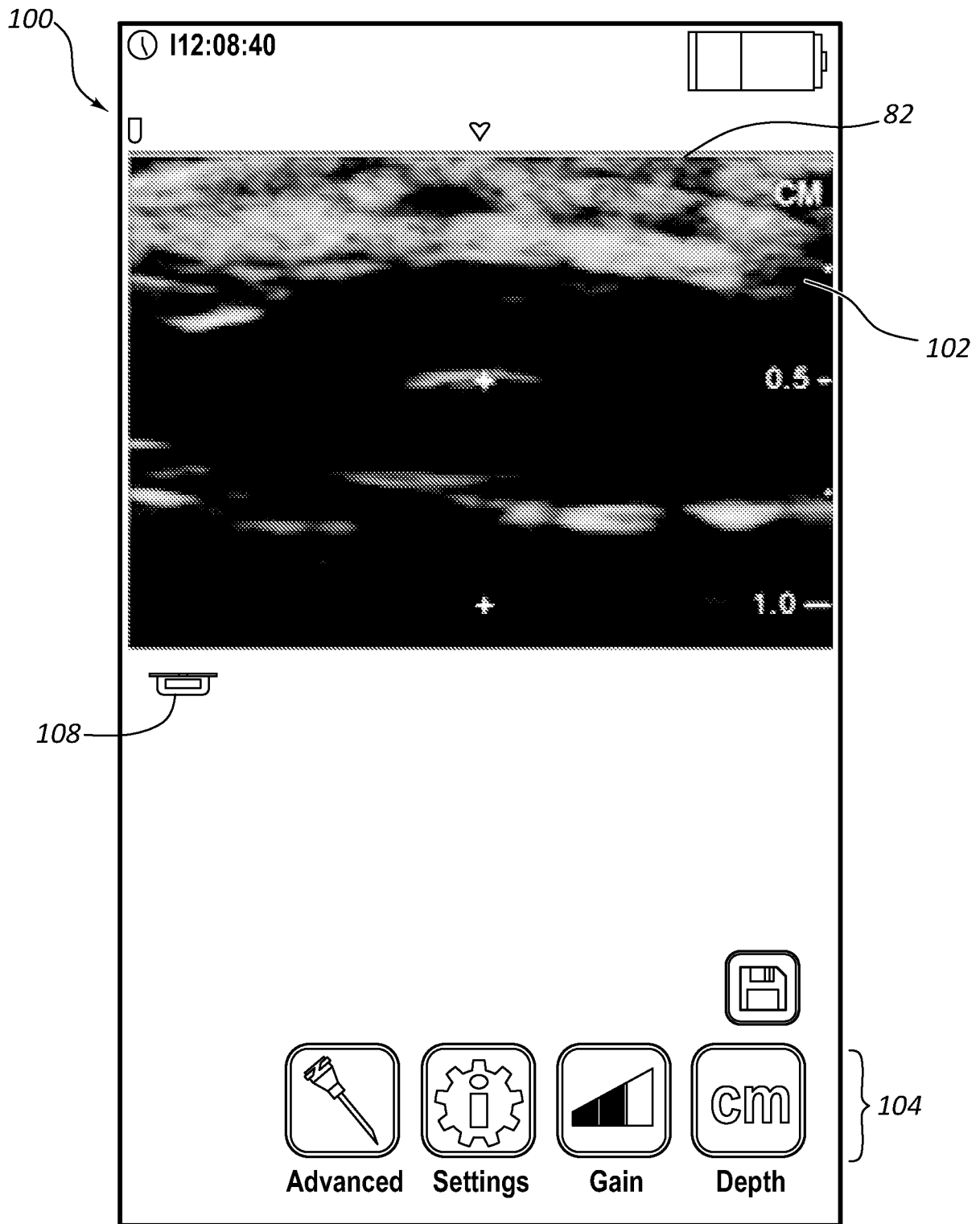

FIG. 8

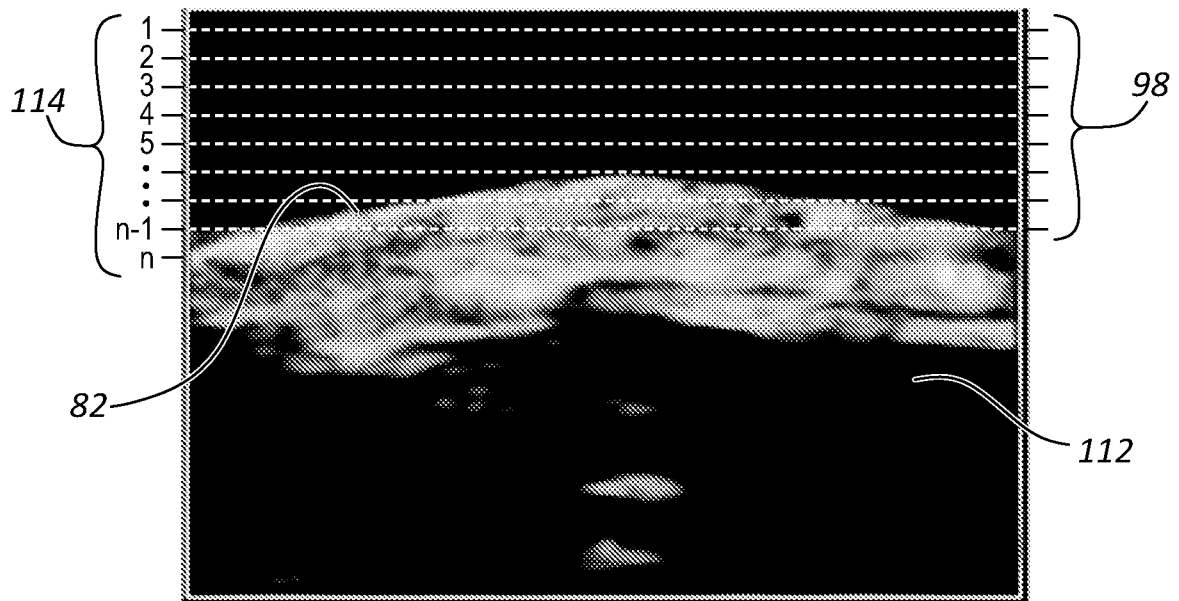

FIG. 9

10/18

120

Zone	Average Image Intensity	\leq Threshold Intensity
1	X_1	YES
2	X_2	YES
3	X_3	NO
⋮	⋮	⋮
N	X_n	YES

FIG. 10

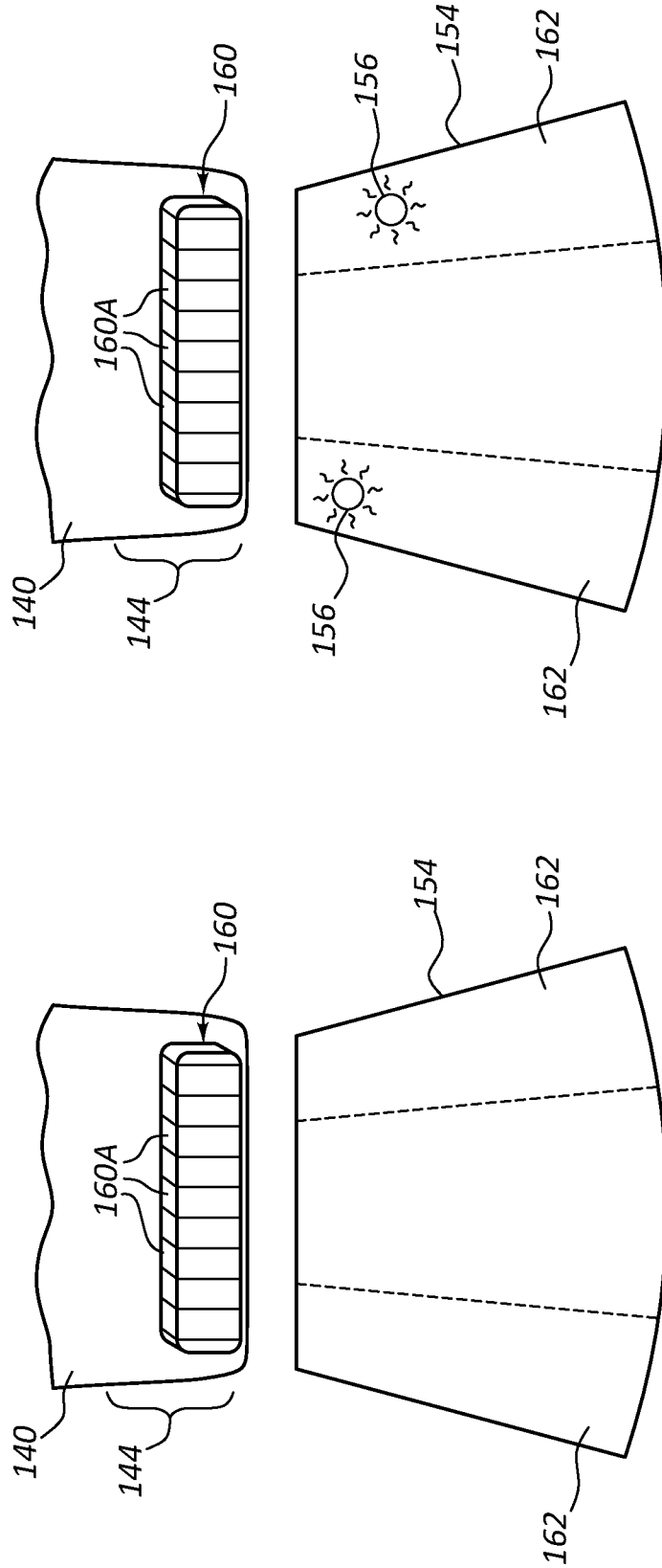

FIG. 11B

FIG. 11A

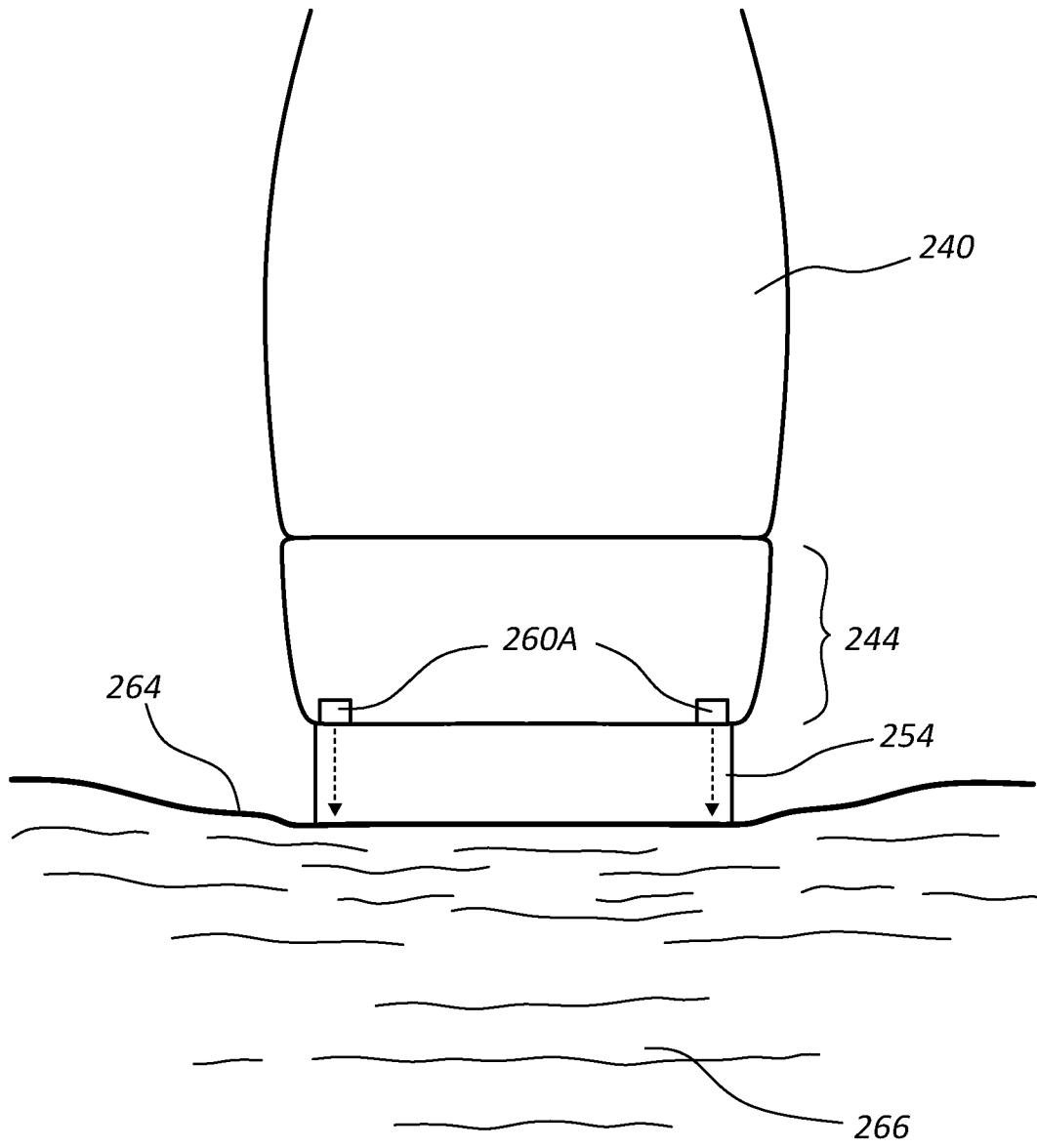

FIG. 12

13/18

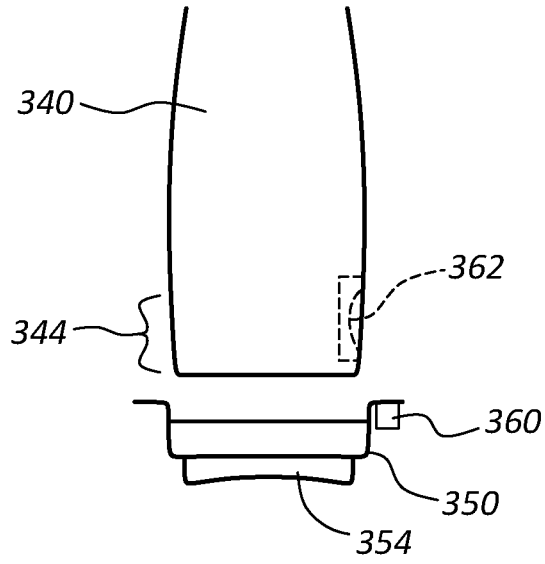

FIG. 13

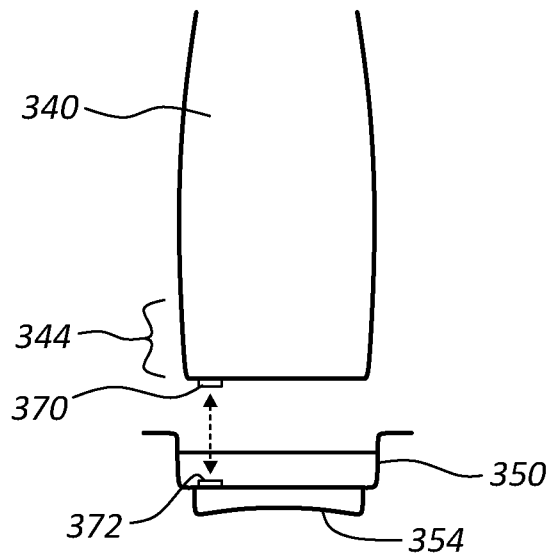

FIG. 14

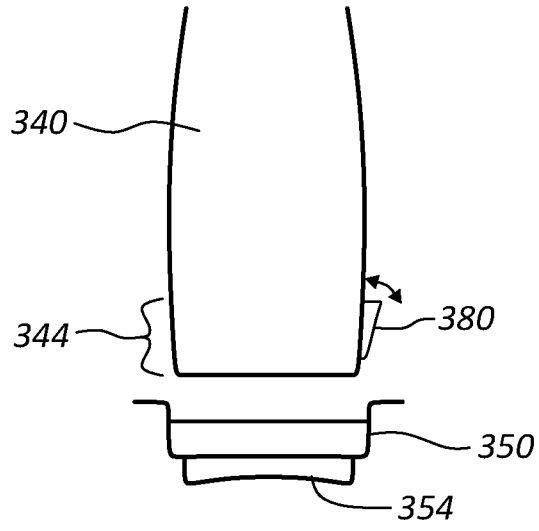

FIG. 15

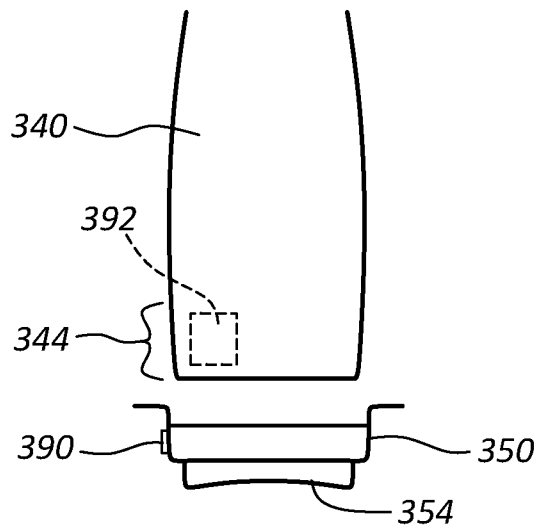

FIG. 16

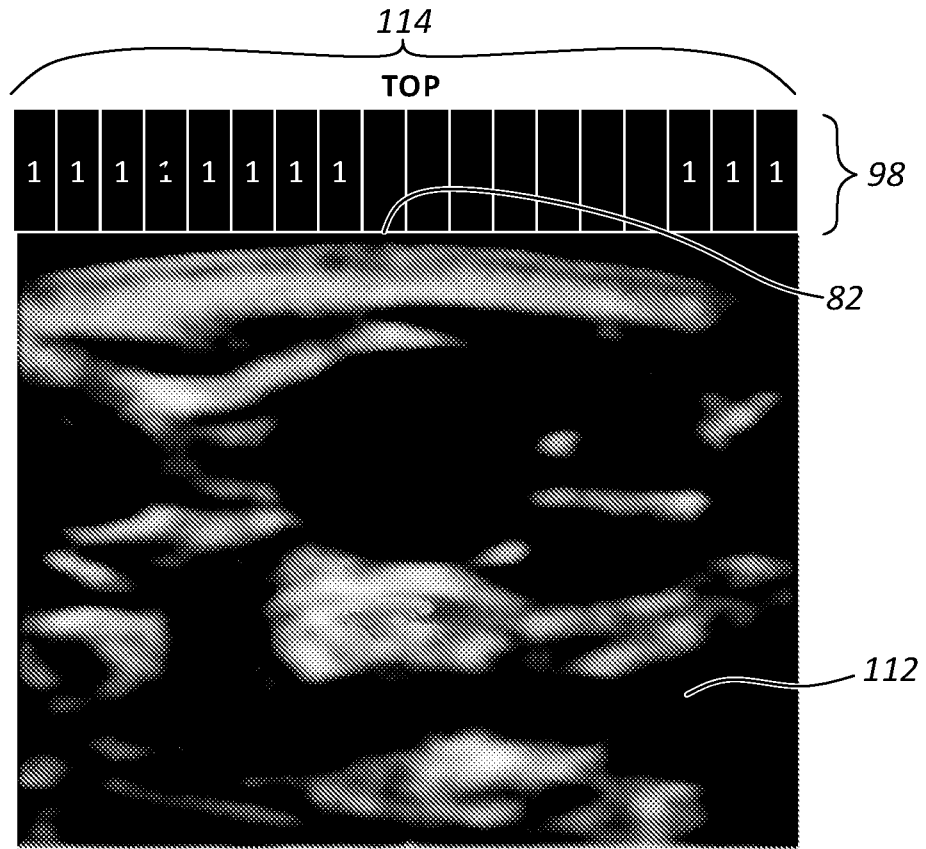
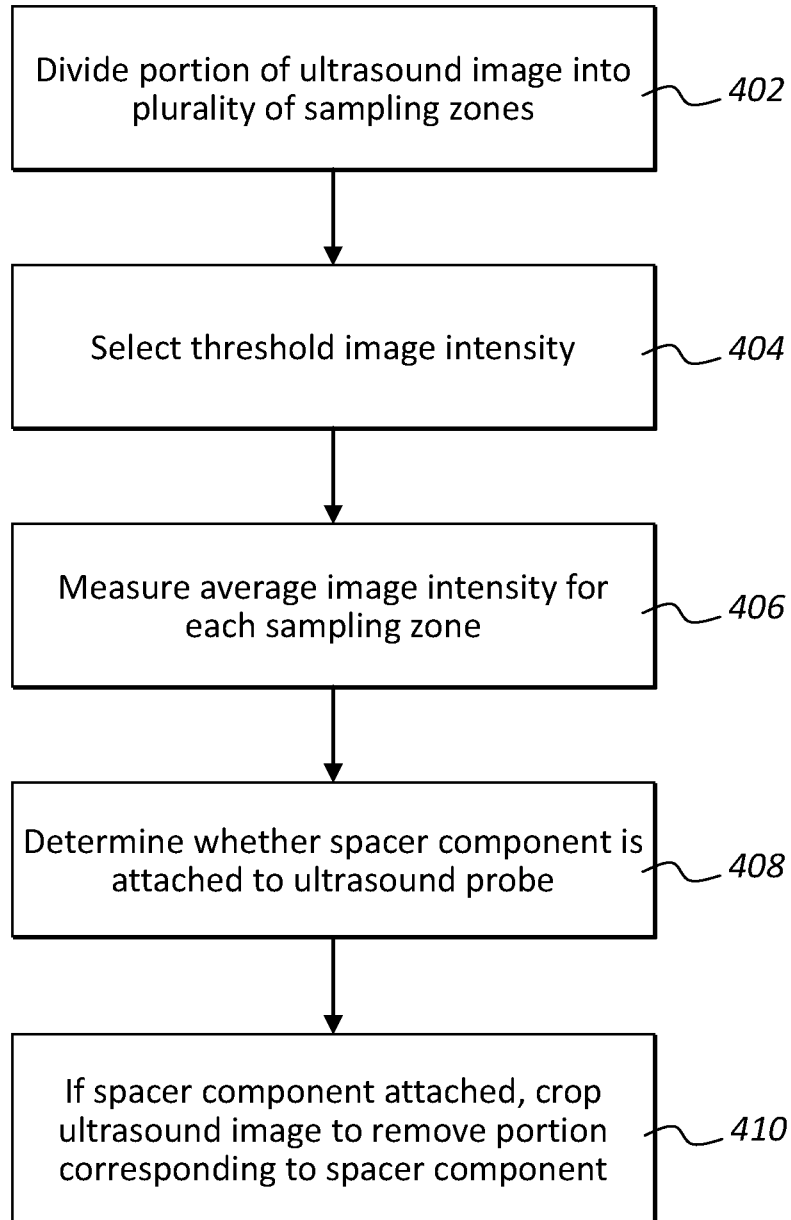

FIG. 17

16/18**FIG. 18**

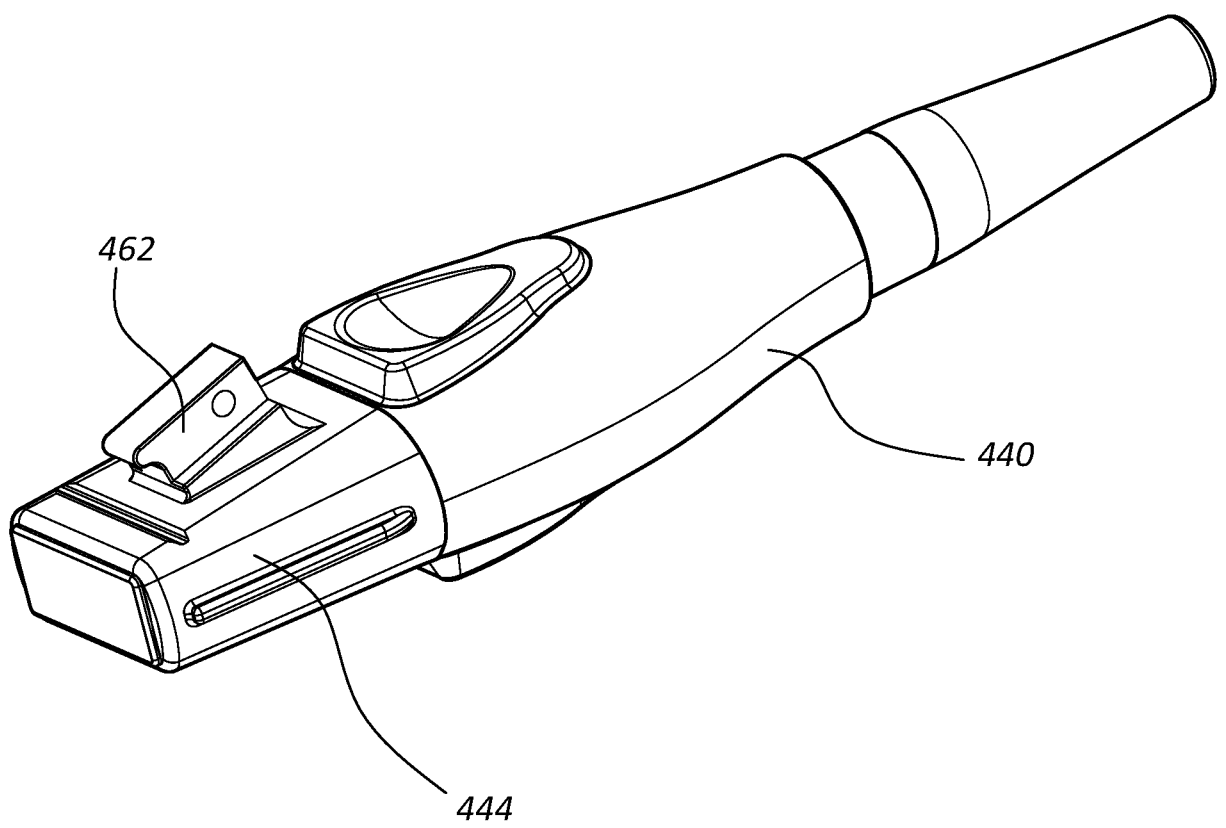

FIG. 19

18/18

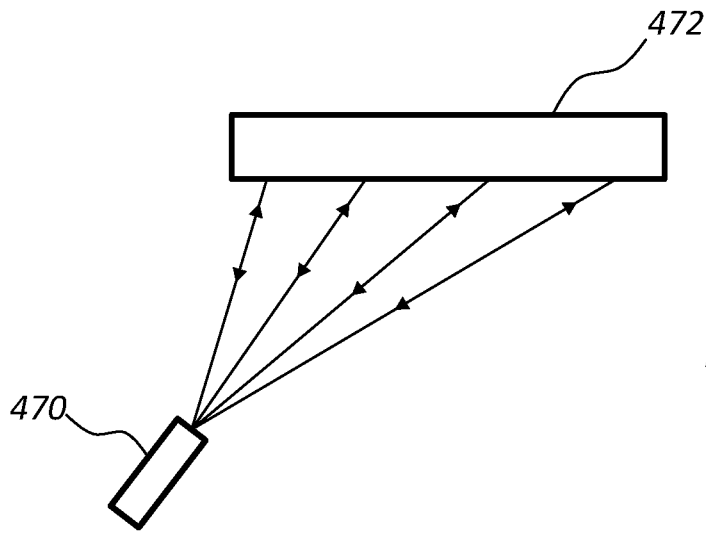

FIG. 20

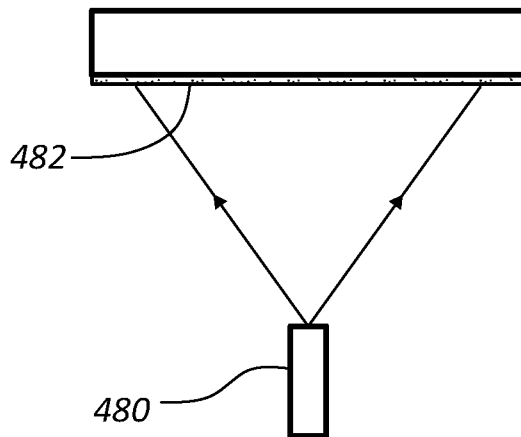

FIG. 21

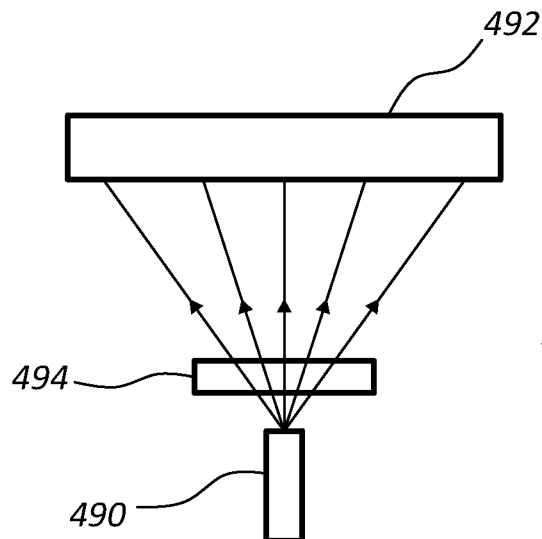

FIG. 22

专利名称(译)	用于检测超声探头上的可移除帽的装置和方法		
公开(公告)号	EP2861153A2	公开(公告)日	2015-04-22
申请号	EP2013804474	申请日	2013-06-14
申请(专利权)人(译)	C.R. BARD , INC.		
当前申请(专利权)人(译)	C.R. BARD , INC.		
[标]发明人	COHEN BENJAMIN A COX JEREMY B SOUTHARD JEANETTE E MESSERLY SHAYNE MUSE JAY A STINGER KEVIN W		
发明人	COHEN, BENJAMIN, A. COX, JEREMY, B. SOUTHARD, JEANETTE, E. MESSERLY, SHAYNE MUSE, JAY, A. STINGER, KEVIN, W.		
IPC分类号	A61B8/00 A61B8/14 A61B8/08		
CPC分类号	A61B8/4411 A61B8/0841 A61B8/4281 A61B8/429 A61B8/4438 A61B8/5292 A61B8/585		
优先权	61/660201 2012-06-15 US		
其他公开文献	EP2861153A4		
外部链接	Espacenet		

摘要(译)

一种超声成像设备，包括确定何时将诸如可移除探针帽的部件附接到超声探头的一部分的能力。在一个实施例中采用这种盖子作为间隔件，以为探头提供支座。探测到超声探头的探头帽附件使得所得到的超声图像能够由超声成像系统自动调节。在一个实施例中，超声成像系统包括超声探头，可附接到探头的帽或其他部件，以及用于检测部件与探头的附接的部件附接检测系统。一旦检测到帽，就修改由成像系统产生的超声图像的一个方面，例如裁剪图像以去除帽的不期望部分，例如间隔部件。