

(19) World Intellectual Property Organization
International Bureau



(43) International Publication Date
10 March 2011 (10.03.2011)

PCT

(10) International Publication Number
WO 2011/028603 A2

(51) International Patent Classification:

A61N 7/00 (2006.01) *A61B 8/13* (2006.01)
A61B 8/00 (2006.01) *B25J 7/00* (2006.01)

(21) International Application Number:

PCT/US2010/046794

(22) International Filing Date:

26 August 2010 (26.08.2010)

(25) Filing Language:

English

(26) Publication Language:

English

(30) Priority Data:

61/237,017 26 August 2009 (26.08.2009) US
12/868,768 26 August 2010 (26.08.2010) US

(71) Applicant (for all designated States except US): **THE REGENTS OF THE UNIVERSITY OF MICHIGAN** [US/US]; 1214 S. University Avenue, 2nd Floor, Ann Arbor, MI 48104-2594 (US).

(72) Inventors; and

(75) Inventors/Applicants (for US only): **ROBERTS, William, W.** [US/US]; 388 Amherst Circle, Saline, MI 48176 (US). **HALL, Timothy, L.** [US/US]; 637 Fifth Street, Ann Arbor, MI 48104 (US). **CAIN, Charles, A.** [US/US]; 4801 Starak Lane, Ann Arbor, MI 48105 (US). **FOWLKES, J., Brian** [US/US]; 627 Sciomeadow Drive, Ann Arbor, MI 48103 (US). **XU, Zhen** [CN/US]; 242 Village Green Blvd., Apt. 202, Ann Arbor, MI 48105 (US). **KUSNER, Michael, Thomas, Jr.** [US/US]; 26659 Sheringham Road, Perrysburg, OH 43551 (US). **TE-**

OFILOVIC, Dejan [US/US]; 6400 Vineyard Avenue, Ann Arbor, MI 48108 (US).

(74) Agents: **SNYDER, Jeffrey, L.** et al.; Harness, Dickey & Pierce, P.L.C., P.O. Box 828, Bloomfield Hills, MI 48303 (US).

(81) Designated States (unless otherwise indicated, for every kind of national protection available): AE, AG, AL, AM, AO, AT, AU, AZ, BA, BB, BG, BH, BR, BW, BY, BZ, CA, CH, CL, CN, CO, CR, CU, CZ, DE, DK, DM, DO, DZ, EC, EE, EG, ES, FI, GB, GD, GE, GH, GM, GT, HN, HR, HU, ID, IL, IN, IS, JP, KE, KG, KM, KN, KP, KR, KZ, LA, LC, LK, LR, LS, LT, LU, LY, MA, MD, ME, MG, MK, MN, MW, MX, MY, MZ, NA, NG, NI, NO, NZ, OM, PE, PG, PH, PL, PT, RO, RS, RU, SC, SD, SE, SG, SK, SL, SM, ST, SV, SY, TH, TJ, TM, TN, TR, TT, TZ, UA, UG, US, UZ, VC, VN, ZA, ZM, ZW.

(84) Designated States (unless otherwise indicated, for every kind of regional protection available): ARIPO (BW, GH, GM, KE, LR, LS, MW, MZ, NA, SD, SL, SZ, TZ, UG, ZM, ZW), Eurasian (AM, AZ, BY, KG, KZ, MD, RU, TJ, TM), European (AL, AT, BE, BG, CH, CY, CZ, DE, DK, EE, ES, FI, FR, GB, GR, HR, HU, IE, IS, IT, LT, LU, LV, MC, MK, MT, NL, NO, PL, PT, RO, SE, SI, SK, SM, TR), OAPI (BF, BJ, CF, CG, CI, CM, GA, GN, GQ, GW, ML, MR, NE, SN, TD, TG).

Published:

— without international search report and to be republished upon receipt of that report (Rule 48.2(g))



WO 2011/028603 A2

(54) Title: MICROMANIPULATOR CONTROL ARM FOR THERAPEUTIC AND IMAGING ULTRASOUND TRANSDUCERS

(57) Abstract: A medical imaging and therapy device is provided that may include any of a number of features. One feature of the device is that it can image a target tissue volume and apply ultrasound energy to the target tissue volume. In some embodiments, the medical imaging and therapy device is configured controllably apply ultrasound energy into the prostate by maintaining a cavitation bubble cloud generated by an ultrasound therapy system within an image of the prostate generated by an imaging system. The medical imaging and therapy device can be used in therapeutic applications such as Histotripsy, Lithotripsy, and HIFU, for example. Methods associated with use of the medical imaging and therapy device are also covered.

MICROMANIPULATOR CONTROL ARM FOR THERAPEUTIC AND IMAGING ULTRASOUND TRANSDUCERS

CROSS REFERENCE TO RELATED APPLICATIONS

5 [0001] This application claims priority to U.S. Patent Application No. 12/868,768,
filed August 26, 2010, titled "MICROMANIPULATOR CONTROL ARM FOR
THERAPEUTIC AND IMAGING ULTRASOUND TRANSDUCERS", and claims the
benefit under 35 U.S.C. 119 of U.S. Provisional Patent Application No. 61/237,017, filed
August 26, 2009, titled "MICROMANIPULATOR CONTROL ARM FOR
10 THERAPEUTIC AND IMAGING ULTRASOUND TRANSDUCERS". These
applications are herein incorporated by reference in their entirety.

INCORPORATION BY REFERENCE

15 [0002] All publications, including patents and patent applications, mentioned in this
specification are herein incorporated by reference in their entirety to the same extent as if
each individual publication was specifically and individually indicated to be incorporated
by reference.

FIELD OF THE INVENTION

20 [0003] The present invention generally relates to imaging and treating tissue with
ultrasound devices. More specifically, the present invention relates to imaging and
ablating tissue with Histotripsy devices.

BACKGROUND OF THE INVENTION

25 [0004] Histotripsy and Lithotripsy are non-invasive tissue ablation modalities that
focus pulsed ultrasound from outside the body to a target tissue inside the body.
Histotripsy mechanically damages tissue through cavitation of micro bubbles which
homogenizes cellular tissues into an acellular liquid that can be expelled or absorbed by
the body, and Lithotripsy is typically used to fragment urinary stones with acoustic
30 shockwaves.

[0005] Histotripsy is the mechanical disruption via acoustic cavitation of a target
tissue volume or tissue embedded inclusion as part of a surgical or other therapeutic

procedure. Histotripsy works best when a whole set of acoustic and transducer scan parameters controlling the spatial extent of periodic cavitation events are within a rather narrow range. Small changes in any of the parameters can result in discontinuation of the ongoing process.

5 [0006] Histotripsy requires high peak intensity acoustic pulses which in turn require large surface area focused transducers. These transducers are often very similar to the transducers used for Lithotripsy and often operate in the same frequency range. The primary difference is in how the devices are driven electrically.

[0007] Histotripsy pulses consist of a (usually) small number of cycles of a sinusoidal driving voltage whereas Lithotripsy is (most usually) driven by a single high voltage pulse with the transducer responding at its natural frequencies. Even though the Lithotripsy pulse is only one cycle, its negative pressure phase length is equal to or greater than the entire length of the Histotripsy pulse, lasting tens of microseconds. This negative pressure phase allows generation and continual growth of the bubbles, resulting in bubbles of sizes up to 1 mm. The Lithotripsy pulses use the mechanical stress produced by a shockwave and these 1 mm bubbles to cause tissue damage or fractionate stones.

[0008] In comparison, each negative and positive cycle of a Histotripsy pulse grows and collapses the bubbles, and the next cycle repeats the same process. The maximal sizes of bubbles reach approximately tens to hundreds of microns. These micron size bubbles interact with a tissue surface to mechanically damage tissue.

[0009] In addition, Histotripsy delivers hundreds to thousands of pulses per second, i.e., 100-1kHz pulse repetition frequency. Lithotripsy only works well within a narrow range of pulse repetition frequency (usually 0.5-1Hz). Studies show that the efficacy and efficiency of lithotripsy decreases significantly when the pulse repetition frequency is increased to 10-100Hz. The reduced efficiency is likely due to the increased number of mm size bubbles blocking the shock waves and other energy from reaching the stone.

[0010] Histotripsy typically comprises delivering acoustic pulses that operate at a frequency between approximately 50 KHz and 5MHz, having a pulse intensity with a peak negative pressure of approximately 8-40 MPa, a peak positive pressure of more than 10 MPa, a pulse length shorter than 50 cycles, a duty cycle between approximately 0.1% and 5% and in some embodiments less than 5%, and a pulse repetition frequency of less than 5 KHz.

[0011] Diagnostic ultrasound can be used during Histotripsy procedures to visualize the surgical anatomy and monitor the process in real time. The Histotripsy cavitation bubble cloud can appear very clearly on diagnostic ultrasound as a hyperechoic (light) region and ablated homogenized tissue can appear as a hypoechoic (dark) region. Large and irregular tissue volumes can be ablated using Histotripsy by electronically changing the focus of a therapeutic array or by mechanically moving the focus of the therapeutic transducer within the surgical target area.

SUMMARY OF THE INVENTION

10 [0012] The present invention relates to an imaging and therapy system comprising a micro-manipulator system, an ultrasound therapy system supported by the micro-manipulator system, and an imaging system supported by the micro-manipulator system apart from the ultrasound therapy system, the micro-manipulator system being adapted and configured to maintain a focal point of the ultrasound therapy system within a field of
15 view of the imaging system.

[0013] In some embodiments, the micro-manipulator is adapted and configured to position the imaging system within a rectum of a human male patient and to position the ultrasound therapy system in acoustic contact with a perineum of the patient while the imaging system is in the rectum. In one embodiment, the imaging system comprises a
20 trans-rectal probe.

[0014] In some embodiments, the focal point of the ultrasound therapy system is approximately 0.8 cm to 4 cm from the imaging system.

[0015] In many embodiments of the imaging and therapy system, the ultrasound therapy system comprises a histotripsy system. The ultrasound therapy system can
25 comprise an ultrasound therapy transducer configured to generate cavitation micro bubbles in tissue. In some embodiments, the ultrasound therapy system comprises an ultrasound therapy transducer configured to deliver acoustic pulses that operate at a frequency between approximately 50 KHz and 5MHz, having a pulse intensity with a peak negative pressure of approximately 8-40 MPa, a peak positive pressure of more than 10
30 MPa, a pulse length shorter than 50 cycles, a duty cycle of less than 5% and in some embodiments less than 5%, and a pulse repetition frequency of less than 5 KHz.

[0016] In some embodiments, the micro-manipulator system comprises a robotic arm. The robotic arm can move in up to six degrees of freedom, for example. In another

embodiment, the micro-manipulator system comprises at least four stepper motors configured to move the micro-manipulator system in up to four degrees of freedom. In one embodiment, one of the at least four stepper motors is configured to rotate the imaging system along a roll axis. In another embodiment, one of the at least four stepper motors is
5 configured to rotate the ultrasound therapy system along a pitch axis. In yet another embodiment, one of the at least four stepper motors is configured to rotate the ultrasound therapy system along a yaw axis. In an additional embodiment, one of the at least four stepper motors is configured to advance the ultrasound therapy system along a forward/back axis.

10 [0017] In some embodiments, the imaging and therapy system can further comprise a control system configured to automatically control the micro-manipulator system to maintain the focal point of the ultrasound therapy system within the field of view of the imaging system. The control system can include a controller, such as a computer, as well as an input device and a display.

15 [0018] Methods of using an imaging and therapy device are also provided. In one embodiment, a method of ablating tissue in a prostate of a patient comprises supporting an imaging system and an ultrasound therapy system on micro-manipulator system, inserting the imaging system into the patient's rectum, generating an image of the prostate with the imaging system, and controllably applying ultrasound energy from the ultrasound therapy
20 system into the prostate by maintaining a bubble cloud generated by the ultrasound therapy system within the image of the prostate generated by the imaging system.

[0019] In some embodiments, the method further comprises placing the ultrasound therapy system in acoustic contact with the patient's perineum.

25 [0020] In another embodiment, the method further comprises maintaining the bubble cloud generated by the ultrasound therapy system within approximately 0.8 cm to 4 cm of the imaging system.

[0021] In an additional embodiment, the controllably applying ultrasound energy step comprises controllably applying Histotripsy therapy. In another embodiment, the controllably applying ultrasound energy step comprises delivering acoustic pulses that
30 operate at a frequency between approximately 50 KHz and 5MHz, having a pulse intensity with a peak negative pressure of approximately 8-40 MPa, a peak positive pressure of more than 10 MPa, a pulse length shorter than 50 cycles, a duty cycle of less than 5% and in some embodiments less than 5%, and a pulse repetition frequency of less than 5 KHz.

In another embodiment, the controllably applying ultrasound energy step further comprises automatically maintaining the bubble cloud generated by the ultrasound therapy system within the image of the prostate generated by the imaging system with a control system.

5 [0022] In some embodiments, the method further comprises mechanically damaging tissue in the prostate. The method can further comprise mechanically damaging tissue in the prostate to treat BPH. In an additional embodiment, the method comprises mechanically damaging tissue in the prostate to treat prostate cancer.

[0023] In one embodiment, the method comprises rotating the imaging system to
10 create a 3D image of the prostate.

BRIEF DESCRIPTION OF THE DRAWINGS

[0024] Fig. 1 illustrates one embodiment of an imaging and therapy system including a micro-manipulator system.

15 [0025] Figs. 2A-2B illustrate an imaging system inside a patient.

[0026] Figs. 3A-3B and 4A-4B illustrate an imaging system and a therapeutic ultrasound transducer attached to a micro-manipulator system.

[0027] Fig. 5 is an ultrasound image of tissue damaged with a Histotripsy procedure.

[0028] Figs. 6A-6B are two views of a micro-manipulator system.

20

DETAILED DESCRIPTION OF THE INVENTION

[0029] Histotripsy may be used to ablate or damage tissue for treatment of a variety of disorders. Particularly, Histotripsy can be used to ablate tissue for the treatment of benign prostate hyperplasia (BPH) and prostate cancer. In one Histotripsy system, an imaging
25 system and an ultrasound therapy system are held and positioned by an electromechanical micro-manipulator system. The micro-manipulator system can be attached to a procedure table or can be held above the procedure table and secured to the ceiling. In some embodiments, the micro-manipulator system can be joystick controlled or controlled by a computer tracking and positioning program. A trans-rectal (TR) ultrasound imaging
30 system can be inserted in the patient's rectum to confirm accurate targeting and localization of the bubble cloud formed by the therapy system during treatment, and for imaging of target tissue during the Histotripsy procedure. The imaging system can be

attached to the micro-manipulator system and repositioned axially and rotated radially during the procedure to image and track therapy.

[0030] One aspect of the invention provides a new micro-manipulator system and method of use for therapeutic and imaging systems in the fields of Histotripsy, Lithotripsy, 5 or HIFU tissue ablation. The micro-manipulator system can be a small, portable and easy to use system and can include attachment points for both an ultrasound therapy system and an imaging system. The micro-manipulator system can be configured to independently control movement of both the therapy system and the imaging system.

[0031] Referring now to Fig. 1, imaging and therapy system 100 can comprise micro- 10 manipulator system 102, control system 104, ultrasound therapy system 106, and imaging system 108. Micro-manipulator system 102 can be adapted and configured to attach to and move the ultrasound therapy system 106 in up to six degrees of freedom (e.g., forward/back, left/right, up/down, yaw, pitch, and roll in the x, y, and z planes shown in Fig. 1). It should be understood that some systems may not require all six degrees of 15 freedom of movement. The micro-manipulator system can also be configured to attach to and move the imaging system in up to six degrees of freedom, however, typically only the forward/back and roll degrees of freedom are required for the imaging system. In some embodiments, the micro-manipulator system comprises a robotic arm with up to six degrees of freedom. The robotic arm can be configured to hold the weight of both the 20 imaging system and the ultrasound therapy system steady during positioning and treatment. In the embodiment of Fig. 1, micro-manipulator system 102 is attached to a separate mobile stand 116. Alternatively, the micro-manipulator system can be mounted on a procedure table (not shown).

[0032] Control system 104 can include controller 110, input device 112, and display 25 114. The controller can be a computer having hardware and software configured to control movement of the micro-manipulator system. For example, the controller can comprise a CPU, memory, operating system, and other computing essentials required to load software and control attached hardware. The input device 112 can be a keyboard and mouse or a joystick, for example. Display 114 can be, for example, an electronic display or a 30 graphical user interface (GUI).

[0033] Ultrasound therapy system 106 can comprise an ultrasound therapy transducer or transducers configured to deliver ultrasound energy to a target tissue volume. In some embodiments, the ultrasound therapy transducer can be a Histotripsy ultrasound transducer

configured to generate cavitation micro bubbles in tissue. In some embodiments, the Histotripsy ultrasound transducer can be configured to deliver acoustic pulses that operate at a frequency between approximately 50 KHz and 5MHz, having a pulse intensity with a peak negative pressure of approximately 8-40 MPa, a peak positive pressure of more than
5 10 MPa, a pulse length shorter than 50 cycles, a duty cycle between approximately 0.1% and 5% and in some embodiments less than 5%, and a pulse repetition frequency of less than 5 KHz. In other embodiments, the ultrasound therapy system 106 can comprise a Lithotripsy ultrasound transducer or a HIFU transducer. The ultrasound therapy system 106 can include a coupling mechanism 118 for acoustically coupling the transducer to a
10 patient, such as a bellows. Alternatively, the coupling mechanism can be separate from the ultrasound therapy system and attached to the patient instead. Several embodiments of a suitable coupling mechanism are described in U.S. Pat. App. No. 12/858,242, filed 8/17/2010, titled "Disposable Acoustic Coupling Medium Container".

[0034] In some embodiments, the imaging system 108 is configured to image the target tissue volume and comprises a C-mode diagnostic ultrasound imaging system. In some embodiments, the imaging system can be a trans-rectal imaging probe. The imaging system can be configured to image tissue in 2D or 3D. In some embodiments, a trans-rectal imaging probe can be configured to be inserted into the rectum of a patient to image the prostate and surrounding tissues. In other embodiments, a secondary imaging
15 transducer may be held in the center of the ultrasound therapy system 106.

[0035] Methods of using a imaging and therapy system will now be described. Fig. 2A illustrates an imaging system 208 inserted in the rectum R of a patient. Imaging transducer 220 of imaging system 208 can be positioned adjacent to the prostate P of the patient. Fig. 2B illustrates the imaging system 208 coupled to a micro-manipulator system
20 202, such as the micro-manipulator system described above. In some embodiments, the imaging system and the micro-manipulator system can be positioned manually at the beginning of the procedure. In some embodiments, the imaging system 208 can be positioned in the rectum, as shown in Fig. 2A, then the micro-manipulator system can be positioned and attached to the imaging system, as shown in Fig. 2B. The imaging system
25 can be advanced in the rectum so that its imaging aperture defined by imaging transducer 220 is adjacent to the prostate and is configured to acquire an image of the prostate in the transverse plane. The imaging system can also be positioned by rotating radially along the
30

longitudinal axis of the probe so as to acquire an image of the prostate in the medial sagittal plane.

[0036] As shown in Figs. 3A-B, ultrasound therapy system 306 can mount on micro-manipulator system 302 such that it is facing the perineal region between the anus and scrotum of the patient. The ultrasound therapy system 306 can be configured to have a focal point of approximately 0.8 cm to 4 cm (such as, e.g., 1 cm) away from the front of the ultrasound therapy system. Thus, referring to Fig. 3B for treatment of the prostate, the ultrasound therapy system can be positioned so as to locate the focal point 322 of the ultrasound therapy system 302 within the field of view of the imaging system 308 and within the prostate to be treated. In Figs. 3A-3B, the micro-manipulator system is adapted and configured to position the imaging system within a rectum of the patient and to position the ultrasound therapy system in acoustic contact with the perineum while the imaging system is in the rectum.

[0037] Movement of the micro-manipulator system, imaging of the target tissue with the imaging system, and treatment of the target tissue with the ultrasound therapy system can be managed, observed, and controlled with a control system, such as control system 104 described above and illustrated in Fig. 1. Referring now to Figs. 4A-B and Fig. 1, the initial positioning of focal point 422 can be established mechanically by the micro-manipulator system 402. As shown in Fig. 4A, ultrasound therapy system 406 can be moved by micro-manipulator system 402 to position focal point 422 on target tissues in the prostate P and within the field of view of the imaging system. The micro-manipulator system is configured to position the focal point 422 on one or both lobes of the prostate, as shown in Figs. 4A-B.

[0038] The micro-manipulator system 402 can be manually positioned by the user, such as a physician, by using input device 112 while under visual guidance from an imaging system 108 and display 114 of Fig. 1. In other embodiments, the micro-manipulator system can also be positioned automatically with a controller, such as controller 110 of Fig. 1. The controller can be programmed with software and/or hardware according to a surgical plan to automatically position and move the micro-manipulator system and the ultrasound therapy system to locate the focal point in the target tissue and ablate the desired tissues within the target tissue volume.

[0039] Referring still to Fig. 1, the imaging system 108 can be integrated with the ultrasound therapy system 106 and control system 104 for surgical planning. Surgical

planning can be facilitated by acquiring multiple transverse or sagittal images of the target tissue volume, such as the prostate, with imaging system 108, and storing these images in controller 110 of control system 104. In some embodiments, scanned images can be spaced approximately 1-10 mm apart. These images can be stored in the controller 110 and inputted into surgical planning software within the controller. The images can be retrieved by the surgical planning software, and the treatment area can then be drawn or marked on each image to identify a desired ablation volume, as illustrated by the ablation volume 524 outlined in Fig. 5.

[0040] In other embodiments, scanning the target tissue volume can comprise rotating the imaging system through the sagittal (longitudinal) plane to acquire images through the entire volume in order to reconstruct a three-dimensional (3D) image of the target tissue volume. Transverse or sagittal plane images can then be acquired and examined by the user or the control system for detailed surgical planning. The treatment volume can be drawn or marked on the image, as described above.

[0041] In some embodiments, the surgical planning software or the user can create a surgical plan within the target tissue volume, such as within the prostate, with subsequent treatment volumes separated by 1 mm increments (e.g., total range 0.2 mm-1 cm). Each treatment target can be assigned a different dose of ultrasound therapy. The ultrasound dose can be determined, e.g., by the number of pulses delivered or the treatment duration in each treatment target. In some embodiments, the ultrasound therapy comprises Histotripsy therapy. Histotripsy can be performed within the planned treatment volume. The treatment can be tracked on the control system display, which can also display the images from the imaging system. In some embodiments, the focal point of the ultrasound therapy transducer can be automatically moved by the micro-manipulator system through the surgical treatment volume (e.g., of the prostate) to ablate the treatment volume under real time imaging from the imaging system. In some embodiments, the ultrasound therapy system is configured to ablate or mechanically damage the treatment volume. The ultrasound therapy system can be configured to ablate or mechanically damage tissue of the prostate to treat BPH or prostate cancer, for example.

[0042] In some embodiments, the initial default position of the imaging system is in the middle of the prostate, and the initial default position of the ultrasound therapy system focal point is within the transverse and sagittal field of view of the imaging system. In some embodiments, the default positions of the imaging and therapy systems may be re-

established by pressing a default control element (e.g., a button or a key) on the control system.

[0043] Referring still to Figs. 4A-B and Fig. 1, the imaging system 408 can be advanced and rotated manually during a Histotripsy procedure to keep the cavitation bubble cloud in the imaging field and to facilitate real time monitoring. Alternatively, the control system can automatically position the micro-manipulator system, imaging system, and the ultrasound therapy system to keep the cavitation bubble cloud in the imaging field. For example, the micro-manipulator system can be rotated and/or advanced in the axial direction automatically by the control system to a degree that is calculated based on the movement of the therapy system and the field of view of the imaging system. As another alternative, imaging feedback can be used to guide the rotation of the imaging system. The imaging system can rotate for small steps, until the imaging feedback indicates a hyperechoic zone (i.e., high backscatter amplitude) in the treatment region, which would indicate a Histotripsy cavitation bubble cloud.

[0044] In some embodiments, the ultrasound therapy system can generate an ultrasonically induced cavitation bubble cloud in a tissue volume using pulsed ultrasound at a frequency of between about 100 kHz and about 5 MHz having high amplitude pressure waves with peak negative pressure above 5 MPa, an ultrasound pulse duration of 1-1000 cycles, a pulse repetition frequency of less than about 5 kHz and a duty cycle less than about 5%.

[0045] In other embodiments, the focused ultrasound therapy transducer generates an ultrasonically induced cavitation bubble cloud in a tissue volume using an ultrasound frequency between about 250 kHz and about 1.5 MHz, high amplitude pressure waves with intensities exceeding 2000 W/cm^2 and peak positive pressure above 20 MPa (such as, e.g., between 30 MPa and 500 MPa) and peak negative pressure less than 5 MPa (such as, e.g., between 5 MPa and 40 MPa), ultrasound pulse duration of less than 30 cycles (such as, e.g., between $0.2 \mu\text{s}$ and $30 \mu\text{s}$ (1 to 20 cycles)), a pulse repetition frequency of less than about 5 kHz and a duty cycle less than about 5%.

[0046] Figs. 1-4 above described and illustrated the micro-manipulator system as a robotic arm. However, Figs. 6A-B illustrate an alternative embodiment of a micro-manipulator system 602. As described above, ultrasound therapy system 606 and imaging system 608 can be attached to the micro-manipulator system. The micro-manipulator system as shown in Figs. 6A can be configured to move the ultrasound therapy system 606

in up to three degrees of freedom (e.g., forward/back, yaw, and pitch) and can be configured to move the imaging system 608 in one degree of freedom (e.g., roll). The micro-manipulator system 602 of Figs. 6A-B can further be automatically controlled by a control system, such as control system 104 of Fig. 1, to automatically position and control
5 the ultrasound therapy system and the imaging systems described herein.

[0047] To achieve rotation along the yaw axis, defined by arrow 626, stepper motor 628 can be attached to slide-block 630 with screw rod 632. The screw rod and slide-block can include mating external and internal threading, respectively. When stepper motor 628 rotates screw rod 632, the threading of screw rod causes slide-block to move linearly along
10 slot 634. Slide-block 630 can be attached to rotation tray 636 with connecting rod 638. The connecting rod can be attached to rotation tray at a position away from rotation pin 640 of the tray. When slide-block moves linearly along slot 634, connecting rod 638 pushes against rotation tray 636, causing the tray, and thus the ultrasound therapy system 606, to rotate in the yaw axis around rotation pin 640.

[0048] The micro-manipulator system can achieve rotation along the pitch axis, defined by arrow 642, in a similar manner. In Fig. 6A, stepper motor 644 can rotate screw rod 646, causing slide-block 648 to move linearly in slot 650. This can cause connecting rod 652 to push against ultrasound therapy system 606 to rotate in the pitch axis around rotation pins 654.
15

[0049] The micro-manipulator system can achieve movement along the forward/back axis, defined by arrow 656, in a similar manner. In Figs. 6A-6B, stepper motor 658 can rotate screw rod 660, causing slide-block 662 to move linearly in slot 664. Slide-block 662 can be attached to frame 666, which is attached to ultrasound therapy system 606. Thus, linear movement of the slide block can cause the frame to move linearly along
20 wheels 668, thereby advancing ultrasound therapy system 606 in the forward/back direction 656.

[0050] The micro-manipulator system can achieve movement of the imaging system 608 in the roll axis, defined by arrow 676 in a similar manner. Stepper motor 670 can be attached directly to imaging system 608 with screw rod 672. Stepper motor 670 can rotate
30 screw rod 672, causing rotation of imaging system 606. The stepper motor 670 may further include knob 674 to allow for manual rotation of imaging system 608.

[0051] As for additional details pertinent to the present invention, materials and manufacturing techniques may be employed as within the level of those with skill in the

relevant art. The same may hold true with respect to method-based aspects of the invention in terms of additional acts commonly or logically employed. Also, it is contemplated that any optional feature of the inventive variations described may be set forth and claimed independently, or in combination with any one or more of the features
5 described herein. Likewise, reference to a singular item, includes the possibility that there are plural of the same items present. More specifically, as used herein and in the appended claims, the singular forms "a," "and," "said," and "the" include plural referents unless the context clearly dictates otherwise. It is further noted that the claims may be drafted to exclude any optional element. As such, this statement is intended to serve as
10 antecedent basis for use of such exclusive terminology as "solely," "only" and the like in connection with the recitation of claim elements, or use of a "negative" limitation. Unless defined otherwise herein, all technical and scientific terms used herein have the same meaning as commonly understood by one of ordinary skill in the art to which this invention belongs. The breadth of the present invention is not to be limited by the subject
15 specification, but rather only by the plain meaning of the claim terms employed.

CLAIMS

What is claimed is:

1. An imaging and therapy system comprising:
a micro-manipulator system;
an ultrasound therapy system supported by the micro-manipulator system; and
an imaging system supported by the micro-manipulator system apart from the ultrasound therapy system;
the micro-manipulator system being adapted and configured to maintain a focal point of the ultrasound therapy system within a field of view of the imaging system.
2. The imaging and therapy system of claim 1 wherein the micro-manipulator is adapted and configured to position the imaging system within a rectum of a human male patient and to position the ultrasound therapy system in acoustic contact with a perineum of the patient while the imaging system is in the rectum.
3. The imaging and therapy system of claim 2 wherein the focal point of the ultrasound therapy system is approximately 0.8 cm to 4 cm from the imaging system.
4. The imaging and therapy system of claim 1 wherein the ultrasound therapy system comprises a histotripsy system.
5. The imaging and therapy system of claim 1 wherein the ultrasound therapy system comprises an ultrasound therapy transducer configured to generate cavitation microbubbles in tissue.
6. The imaging and therapy system of claim 1 wherein the ultrasound therapy system comprises an ultrasound therapy transducer configured to deliver acoustic pulses that operate at a frequency between approximately 50 KHz and 5MHz, having a pulse intensity with a peak negative pressure of approximately 8-40 MPa, a peak positive pressure of more than 10 MPa, a pulse length shorter than 50 cycles, a duty cycle of less than 5%, and a pulse repetition frequency of less than 5 KHz.

7. The imaging and therapy system of claim 1 wherein the imaging system comprises a trans-rectal probe.

8. The imaging and therapy system of claim 1 wherein the micro-manipulator system comprises a robotic arm.

9. The imaging and therapy system of claim 8 wherein the robotic arm can move in up to six degrees of freedom.

10. The imaging and therapy system of claim 1 wherein the micro-manipulator system comprises at least four stepper motors configured to move the micro-manipulator system in up to four degrees of freedom.

11. The imaging and therapy system of claim 10 wherein one of the at least four stepper motors is configured to rotate the imaging system along a roll axis.

12. The imaging and therapy system of claim 10 wherein one of the at least four stepper motors is configured to rotate the ultrasound therapy system along a pitch axis.

13. The imaging and therapy system of claim 10 wherein one of the at least four stepper motors is configured to rotate the ultrasound therapy system along a yaw axis.

14. The imaging and therapy system of claim 10 wherein one of the at least four stepper motors is configured to advance the ultrasound therapy system along a forward/back axis.

15. The imaging and therapy system of claim 1 further comprising a control system configured to automatically control the micro-manipulator system to maintain the focal point of the ultrasound therapy system within the field of view of the imaging system.

16. A method of ablating tissue in a prostate of a patient, comprising:
supporting an imaging system and an ultrasound therapy system on micro-manipulator system;
inserting the imaging system into the patient's rectum;
generating an image of the prostate with the imaging system; and
controllably applying ultrasound energy from the ultrasound therapy system into the prostate by maintaining a bubble cloud generated by the ultrasound therapy system within the image of the prostate generated by the imaging system.

17. The method of claim 16 further comprising placing the ultrasound therapy system in acoustic contact with the patient's perineum.

18. The method of claim 16 wherein the controllably applying ultrasound energy step further comprises maintaining the bubble cloud generated by the ultrasound therapy system within approximately 0.8 cm to 4 cm of the imaging system.

19. The method of claim 16 wherein the controllably applying ultrasound energy step comprises controllably applying Histotripsy therapy.

20. The method of claim 16 wherein the controllably applying ultrasound energy step comprises delivering acoustic pulses that operate at a frequency between approximately 50 KHz and 5MHz, having a pulse intensity with a peak negative pressure of approximately 8-40 MPa, a peak positive pressure of more than 10 MPa, a pulse length shorter than 50 cycles, a duty cycle of less than 5%, and a pulse repetition frequency of less than 5 KHz.

21. The method of claim 16 wherein the controllably applying ultrasound energy step further comprises automatically maintaining the bubble cloud generated by the ultrasound therapy system within the image of the prostate generated by the imaging system with a control system.

22. The method of claim 16 further comprising mechanically damaging tissue in the prostate.

23. The method of claim 22 further comprising mechanically damaging tissue in the prostate to treat BPH.

24. The method of claim 22 further comprising mechanically damaging tissue in the prostate to treat prostate cancer.

25. The method of claim 22 further comprising rotating the imaging system to create a 3D image of the prostate.

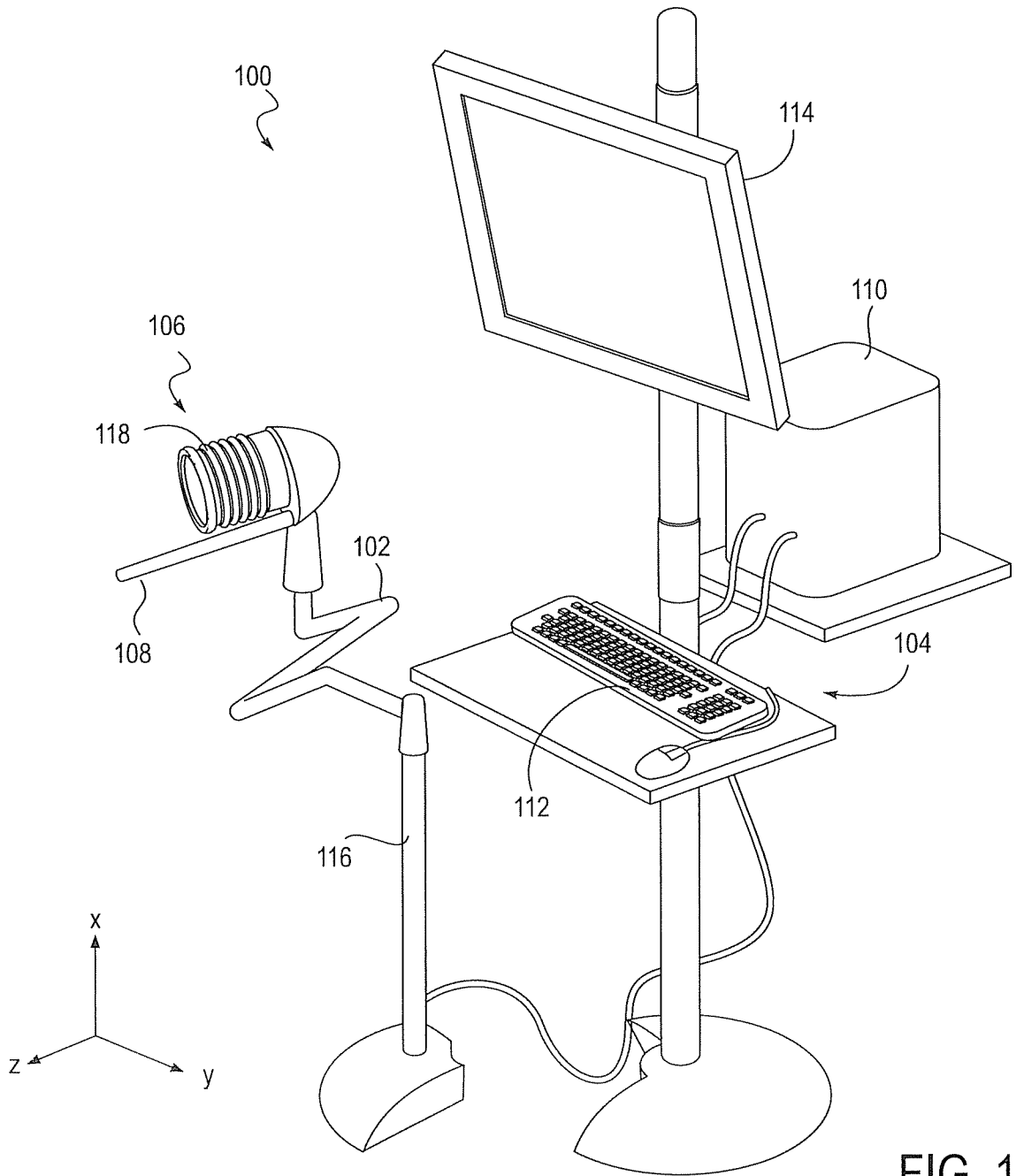

FIG. 1

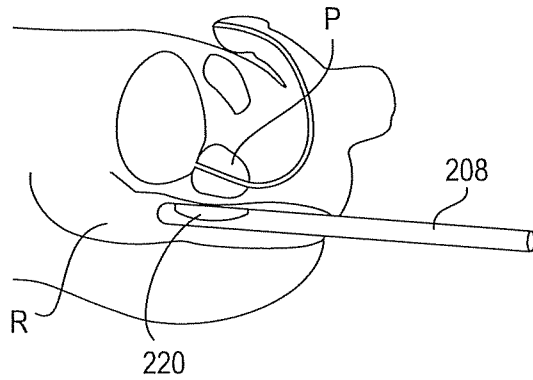

FIG. 2A

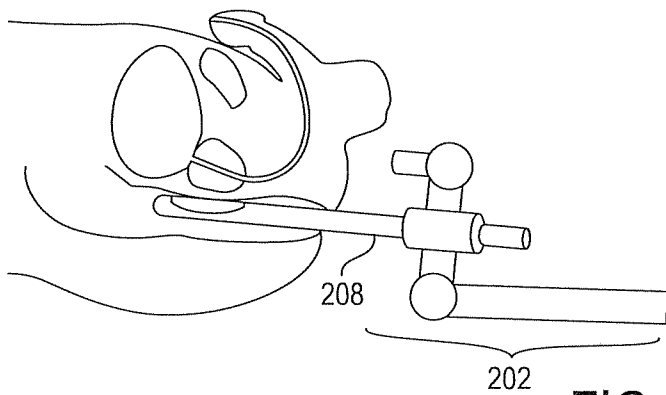

FIG. 2B

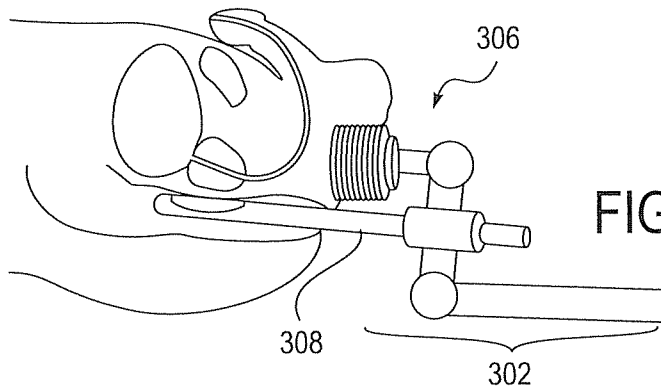

FIG. 3A

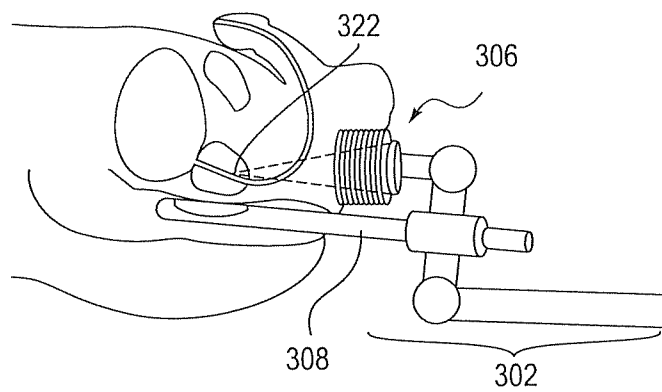
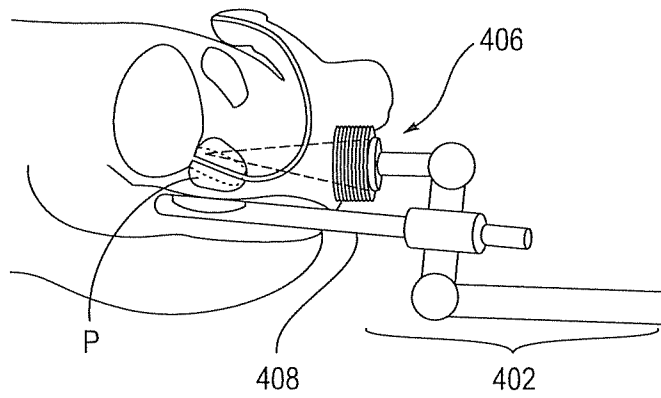
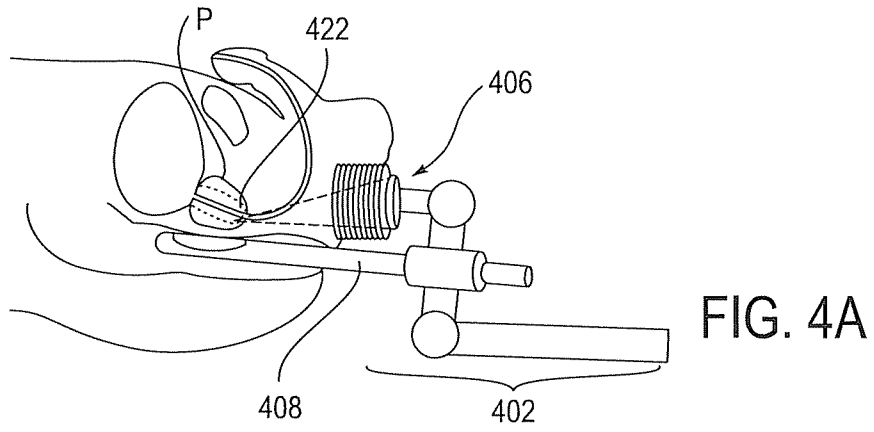

FIG. 3B



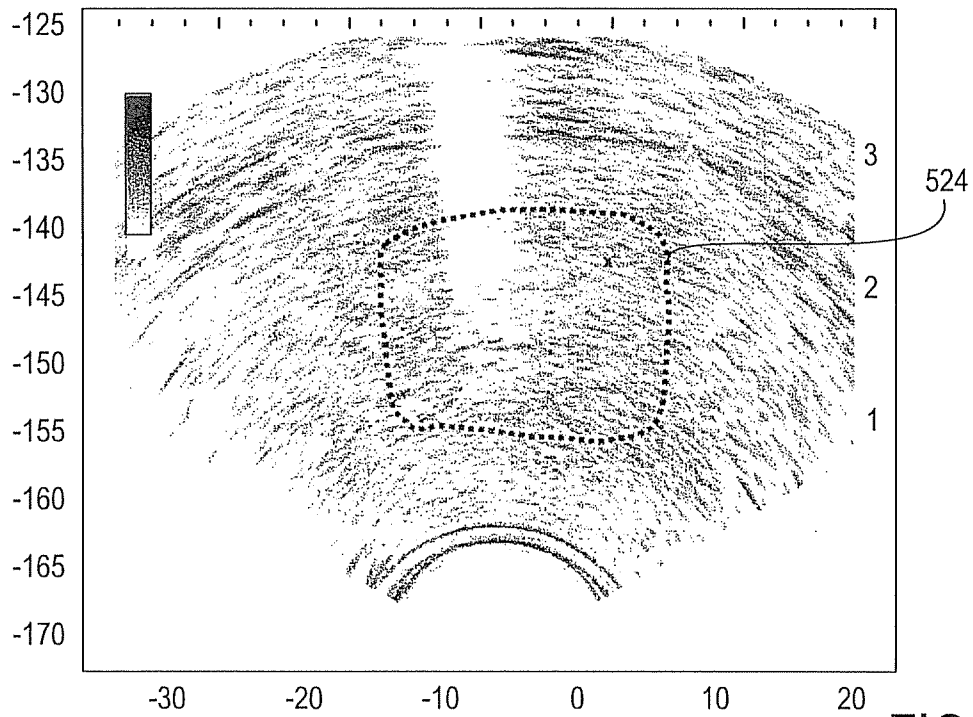

FIG. 5

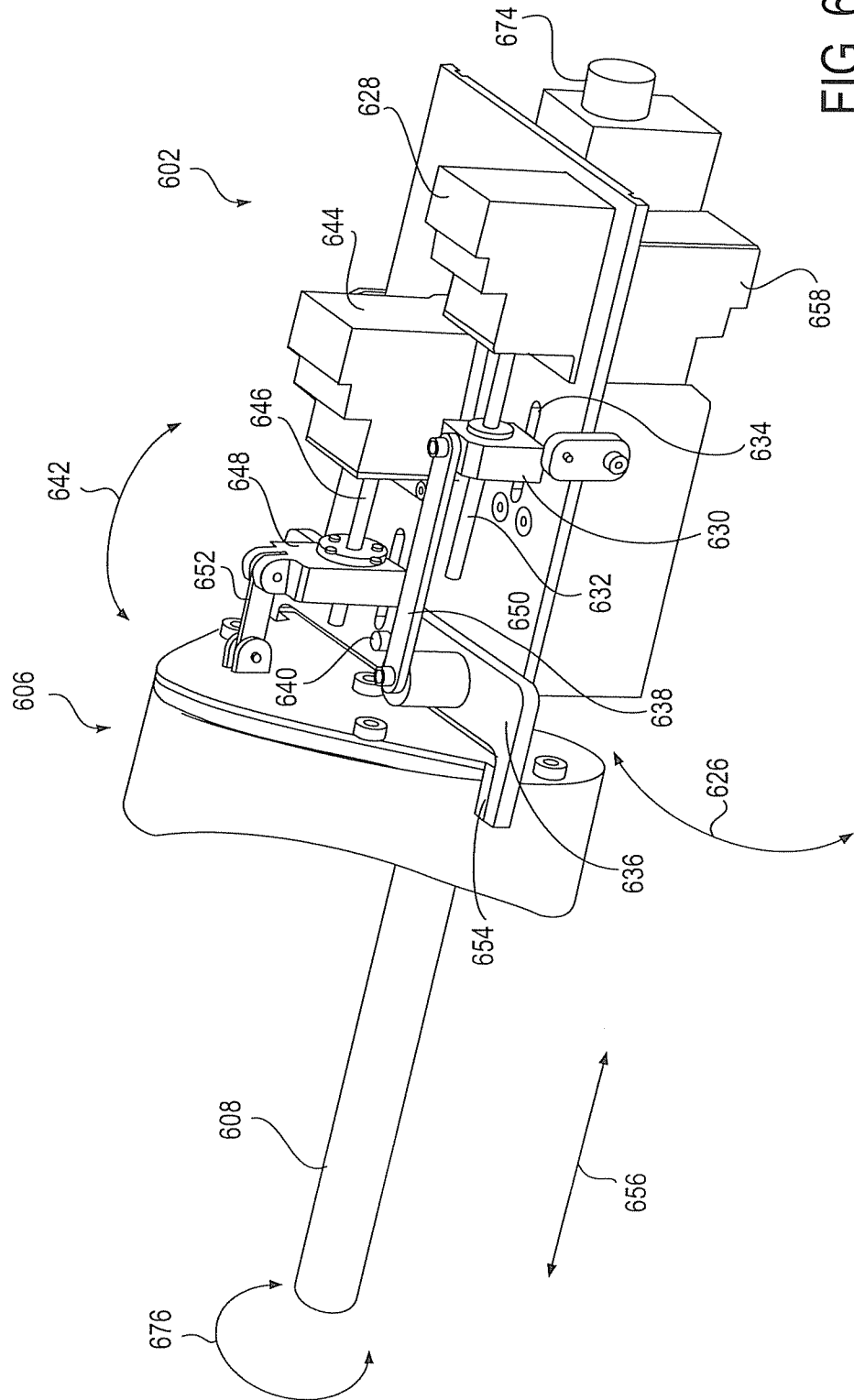

FIG. 6A

Attorney Docket No. 2115-4271POA
HistoSonics Docket No.: 10860-500.200

6/6

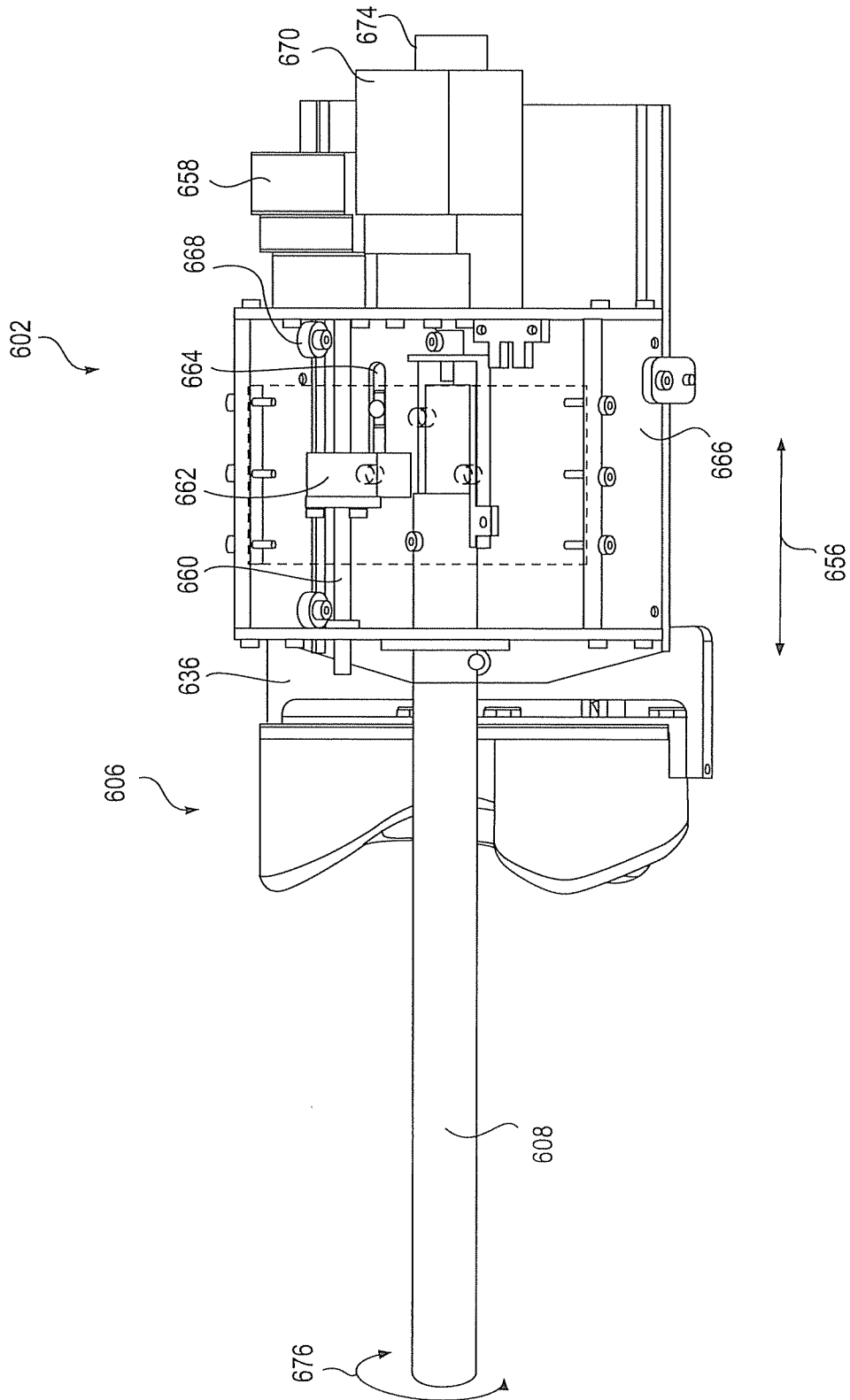

FIG. 6B

专利名称(译)	用于治疗 and 成像超声换能器的微操纵器控制臂		
公开(公告)号	EP2470267A2	公开(公告)日	2012-07-04
申请号	EP2010814299	申请日	2010-08-26
[标]申请(专利权)人(译)	密歇根大学 HISTOSONICS		
申请(专利权)人(译)	密歇根大学董事会 HISTOSONICS INC.		
当前申请(专利权)人(译)	密歇根大学董事会 HISTOSONICS INC.		
[标]发明人	ROBERTS WILLIAM W HALL TIMOTHY L CAIN CHARLES A FOWLKES J BRIAN XU ZHEN KUSNER MICHAEL THOMAS JR TEOFILOVIC DEJAN		
发明人	ROBERTS, WILLIAM, W. HALL, TIMOTHY, L. CAIN, CHARLES, A. FOWLKES, J., BRIAN XU, ZHEN KUSNER, MICHAEL, THOMAS, JR. TEOFILOVIC, DEJAN		
IPC分类号	A61N7/00 A61B8/00 A61B8/13 B25J7/00		
CPC分类号	A61N7/02 A61B8/12 A61B8/4218 A61B34/72 A61B90/50 A61B2017/22008 A61B2090/378		
优先权	61/237017 2009-08-26 US		
其他公开文献	EP2470267B1 EP2470267A4		
外部链接	Espacenet		

摘要(译)

提供了一种医学成像和治疗设备，其可以包括许多特征中的任何一个。该装置的一个特征是它可以成像目标组织体积并将超声能量施加到目标组织体积。在一些实施例中，医学成像和治疗设备被配置为通过维持由成像系统产生的前列腺图像内的超声治疗系统产生的空化气泡云来可控地将超声能量施加到前列腺中。医学成像和治疗装置可用于治疗应用，例如Histotripsy，Lithotripsy和HIFU。还涉及与使用医学成像和治疗装置相关的方法。