

(19) World Intellectual Property Organization
International Bureau



(43) International Publication Date
5 August 2004 (05.08.2004)

PCT

(10) International Publication Number
WO 2004/064619 A2

- (51) International Patent Classification⁷: **A61B**
 - (21) International Application Number: PCT/US2004/000887
 - (22) International Filing Date: 14 January 2004 (14.01.2004)
 - (25) Filing Language: English
 - (26) Publication Language: English
 - (30) Priority Data:

60/440,020	14 January 2003 (14.01.2003)	US
60/439,990	14 January 2003 (14.01.2003)	US
60/440,262	15 January 2003 (15.01.2003)	US
 - (71) Applicant (for all designated States except US): **UNIVERSITY OF VIRGINIA PATENT FOUNDATION** [US/US]; 1224 West Main Street, Suite 1-110, Charlottesville, VA 22903 (US).
 - (72) Inventors; and
 - (75) Inventors/Applicants (for US only): **BLALOCK, Travis, N.** [US/US]; 3085 Beaumont Farm Road, Charlottesville, VA 22901 (US). **WALKER, William, F.** [US/US]; 3822 Burnley Station Road, Barboursville, VA 22923 (US). **HOSSACK, John, A.** [GB/US]; 617 Davis Avenue, Charlottesville, VA 22901 (US).
 - (74) Agents: **MCKIERNAN, Thomas, E.** et al.; 1425 K Street N.W., Suite 800, Washington, DC 20005 (US).
 - (81) Designated States (unless otherwise indicated, for every kind of national protection available): AE, AG, AL, AM, AT, AU, AZ, BA, BB, BG, BR, BW, BY, BZ, CA, CH, CN, CO, CR, CU, CZ, DE, DK, DM, DZ, EC, EE, EG, ES, FI, GB, GD, GE, GH, GM, HR, HU, ID, IL, IN, IS, JP, KE, KG, KP, KR, KZ, LC, LK, LR, LS, LT, LU, LV, MA, MD, MG, MK, MN, MW, MX, MZ, NA, NI, NO, NZ, OM, PG, PH, PL, PT, RO, RU, SC, SD, SE, SG, SK, SL, SY, TJ, TM, TN, TR, TT, TZ, UA, UG, US, UZ, VC, VN, YU, ZA, ZM, ZW.
 - (84) Designated States (unless otherwise indicated, for every kind of regional protection available): ARIPO (BW, GH, GM, KE, LS, MW, MZ, SD, SL, SZ, TZ, UG, ZM, ZW), Eurasian (AM, AZ, BY, KG, KZ, MD, RU, TJ, TM), European (AT, BE, BG, CH, CY, CZ, DE, DK, EE, ES, FI, FR, GB, GR, HU, IE, IT, LU, MC, NL, PT, RO, SE, SI, SK, TR), OAPI (BF, BJ, CF, CG, CI, CM, GA, GN, GQ, GW, ML, MR, NE, SN, TD, TG).
- Published:**
— without international search report and to be republished upon receipt of that report
- For two-letter codes and other abbreviations, refer to the "Guidance Notes on Codes and Abbreviations" appearing at the beginning of each regular issue of the PCT Gazette.*

(54) Title: ULTRASOUND IMAGING BEAM-FORMER APPARATUS AND METHOD

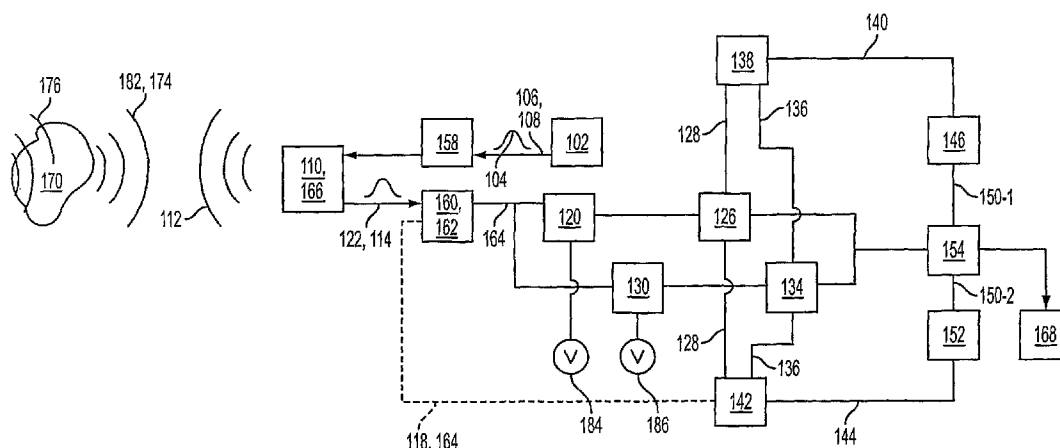

(57) Abstract: In some illustrative embodiments, an incoming signal from a transducer in an ultrasound imaging beam-former apparatus is applied to an in-phase sample-and-hold and a quadrature sample-and-hold. The quadrature sample-and-hold may be clocked a quarter period behind the in-phase sample-and-hold. The output of the sample-and-holds are applied to in-phase and quadrature analog-to-digital converters. A magnitude calculator receives the in-phase and quadrature digital values, and outputs a magnitude. A phase calculator receives the in-phase and quadrature digital values, and outputs a phase. An apodizer applies a difference between an amplitude of the outgoing signal and the magnitude and applies a first illumination to a image point in substantial proportion to the difference, and a phase rotator applies a second illumination to the image point in substantial proportion to the phase.

WO 2004/064619 A2

ULTRASOUND IMAGING BEAM-FORMER APPARATUS AND METHOD

Cross-reference to Related Applications:

5 [0001] This application claims priority from U.S. Provisional Applications Serial Nos. 60/440,020 filed on January 14, 2003, 60/439,990 filed on January 14, 2003, and 60/440,262 filed on January 15, 2003 the entire disclosures of which are incorporated herein by reference.

10 [0002] This application is related to the co-pending PCT International application by the present inventors entitled "Ultrasonic Transducer Drive," filed January 14, 2004 and claiming priority from the above-mentioned U.S. Provisional Application Serial No. 60/440,020, the entire disclosure of which is incorporated herein by reference.

15 [0003] The present application is also related to International Application No. PCT/US03/06607, filed March 6, 2003, entitled "An Intuitive Ultrasonic Imaging System and Related Method Thereof," of which is assigned to the present assignee and is hereby incorporated by reference herein in its entirety. The present invention may be implemented with the technology discussed throughout aforementioned International Application No. PCT/US03/06607.

20

BACKGROUND

Field of the Invention:

25 [0004] The present invention relates to ultrasonic diagnostic imaging systems and methods. More specifically, the preferred embodiments relate to a device and method for ultrasound imaging beam-forming that may be incorporated in a substantially integrated hand-held ultrasonic diagnostic imaging instrument.

Introduction:

30 [0005] Medical imaging is a field dominated by high cost systems that may be so complex as to require specialized technicians for operation and the services of experienced medical doctors and nurses for image interpretation. Medical ultrasound, which is considered a low cost modality, utilizes imaging systems costing as much as \$250K. These systems may be operated by technicians with

two years of training or specialized physicians. This high-tech, high-cost approach works very well for critical diagnostic procedures. However it makes ultrasound impractical for many of the routine tasks for which it would be clinically useful.

5 [0006] A number of companies have attempted to develop low cost, easy to use systems for more routine use. The most notable effort is that by Sonosite. Their system produces very high quality images at a system cost of approximately \$20,000. While far less expensive than high- end systems, these systems are still very sophisticated and require a well-trained operator. Furthermore, at this price few new applications may be opened.

10 [0007] Many ultrasonic imaging systems utilize an array transducer that is connected to beamformer circuitry through a cable, and a display that is usually connected directly to or integrated with the beam-former. This approach is attractive because it allows the beamformer electronics to be as large as is needed to produce an economical system. In addition, the display may be of a very high
15 quality.

[0008] Some conventional system architectures have been improved upon through reductions in beam-former size. One of the most notable efforts has been undertaken by Advanced Technologies Laboratories and then continued by a spin-off company, Sonosite. U.S. Patent No. 6,135,961 to Pflugrath et al., entitled
20 "Ultrasonic Signal Processor for a Hand Held Ultrasonic Diagnostic Instrument," hereby incorporated by reference herein in its entirety, describes some of the signal processing employed to produce a highly portable ultrasonic imaging system. The Pflugrath '961 patent makes reference to an earlier patent, U.S. Patent No. 5,817,024 to Ogle et al., entitled, "Hand Held Ultrasonic Diagnostic instrument with
25 Digital Beamformer," hereby incorporated by reference herein in its entirety. In U.S. Patent No. 6,203,498 to Bunce et al., entitled "Ultrasonic Imaging Device with Integral Display," hereby incorporated by reference herein in its entirety, however, the transducer, beamformer, and display may be all integrated to produce a very small and convenient imaging system.

30 [0009] Other references of peripheral interest are US 6,669,641 to Poland, et al., entitled "Method of and system for ultrasound imaging," which describes an ultrasonic apparatus and method in which a volumetric region of the body is imaged

by biplane images. One biplane image has a fixed planar orientation to the transducer, and the plane of the other biplane image can be varied in relation to the fixed reference image.

5 [0010] US 6,491,634 to Leavitt, et al., entitled "Sub-beam-forming apparatus and method for a portable ultrasound imaging," describes a sub-beam-forming method and apparatus that is applied to a portable, one-dimensional ultrasonic imaging system. The sub-beam-forming circuitry may be included in the probes assembly housing the ultrasonic transducer, thus minimizing the number of signals that are communicated between the probe assembly and the portable processor included in
10 the imaging system.

[0011] US 6,380,766 to Savord, entitled "Integrated circuitry for use with transducer elements in an imaging system," describes integrated circuitry for use with an ultrasound transducer of an ultrasound imaging system.

15 [0012] US 6,013,032 to Savord, entitled "Beam-forming methods and apparatus for three-dimensional ultrasound imaging using two-dimensional transducer array," describes an ultrasound imaging system including a two-dimensional array of ultrasound transducer elements that define multiple sub-arrays, a transmitter for transmitting ultrasound energy into a region of interest with transmit elements of the array, a sub-array processor and a phase shift network associated with each of the
20 sub-arrays, a primary beam-former and an image generating circuit.

[0013] US 6,126,602 to Savord, et al., entitled "Phased array acoustic systems with intra-group processors," describes an ultrasound imaging apparatus and method that uses a transducer array with a very large number of transducer elements or a transducer array with many more transducer elements than beam-
25 former channels.

[0014] US 5,997,479 to Savord, et al., entitled "Phased array acoustic systems with intra-group processors," describes an ultrasound imaging apparatus and method that uses a transducer array with a very large number of transducer elements or a transducer array with many more transducer elements than beam-
30 former channels.

[0015] US 6,582,372 to Poland, entitled "Ultrasound system for the production of 3-D images," describes an ultrasound system that utilizes a probe in conjunction

with little or no specialized 3-D software/hardware to produce images having depth cues.

5 [0016] US 6,179,780 to Hossack, et al., entitled "Method and apparatus for medical diagnostic ultrasound real-time 3-D transmitting and imaging," describes a medical diagnostic ultrasound real-time 3-D transmitting and imaging system that generates multiple transmit beam sets using a 2-D transducer array.

10 [0017] US 6,641,534 to Smith, et al., entitled "Methods and devices for ultrasound scanning by moving sub-apertures of cylindrical ultrasound transducer arrays in two dimensions," describes methods of scanning using a two dimensional (2-D) ultrasound transducer array.

[0018] US 4,949,310 to Smith, et al., entitled "Maltese cross processor: a high speed compound acoustic imaging system," describes an electronic signal processing device which forms a compound image for any pulse-echo ultrasound imaging system using a two-dimensional array transducer.

15 [0019] US 6,276,211 to Smith, entitled "Methods and systems for selective processing of transmit ultrasound beams to display views of selected slices of a volume," describes the selection of a configuration of slices of a volume, such as B slices, I slices, and/or C slices.

20 [0020] Commercial ultrasound systems have been limited to one-dimensional (1-D) or linear transducer arrays until fairly recently. A typical number of transducers in such an array may be 128. Providing separate multiplex and receive circuitry is manageable with this many transducers, albeit with significant use of expensive high-voltage switches. Newer arrays, however, may be likely to be two-dimensional (2-D) or square arrays. The number of transducers in a two-dimensional array may range up to 128 X 128 or 16,384, and is often in the thousands. Maintaining separate receive, transmit, and multiplex partitioning for the transducers in such an array creates a tremendous burden in terms of cost, space, and complexity. The power consumption and heat dissipation of thousands high-voltage multiplexers is enough to discourage the use of two-dimensional arrays in portable ultrasound
25
30 imaging systems.

[0021] Current beam-forming strategies can be broadly classified into the two approaches depicted in Fig. 5. One approach is to use digital time delays to focus

the data, as illustrated in 5(a). Geometric delays are calculated and applied to the digitized data on each channel. In such beam-formers, the data needs to either be sampled at a very high sampling rate or interpolated. Implementation of time delays requires sufficient memory to hold a few hundred samples per channel to implement an adequate delay envelope, constraining system complexity.

[0022] In the second approach, systems combine time delays with complex phase rotation, as depicted in 5(b). Coarse focusing is implemented by delaying the digitized data on each channel. Fine focusing is accomplished by phase rotation of data that has undergone complex demodulation at the center frequency. Such systems require circuitry to perform complex demodulation on every channel. Time delay beam-forming requires significant fast memory to implement a reasonable delay envelope.

[0023] Conventional approaches to generating I/Q data may also include analog/digital baseband demodulation, or use a Hilbert transform. Using a demodulation based approach to generate I/Q data may necessitate significant extra circuitry on each channel, while use of the Hilbert transform may require a significant amount of memory to hold the raw RF data.

[0024] Accordingly, existing ultrasound systems with thousands of separate transmit and receive switches may be too expensive for many applications. While a variety of systems and methods may be known, there remains a need for improved systems and methods.

BRIEF DESCRIPTION OF THE DRAWINGS

[0025] The preferred embodiments of the present invention are shown by a way of example, and not limitation, in the accompanying figures, in which:

FIG. 1 is a schematic diagram of an ultrasound imaging beam-forming apparatus according to a first embodiment of the invention;

FIG. 2 is a schematic diagram of a protection circuit for use with an embodiment of the invention;

FIG. 3 is a schematic diagram of a protection circuit for use with an

embodiment of the invention;

FIG. 4 is a schematic diagram of an ultrasound imaging beam-forming apparatus according to a second embodiment of the invention;

5 FIG. 5 is a schematic diagram of a conventional ultrasound imaging beam-forming apparatus;

FIG. 6 are graphs of signals for use with an embodiment of the invention; and

FIG. 7 is a schematic diagram of a signal receiver for use with an embodiment of the invention.

10

SUMMARY OF THE INVENTION

[0026] The present invention ultrasound imaging beam-former may be incorporated in an ultrasonic imaging system convenient enough to be a common component of nearly every medical examination and procedure. The present invention ultrasound imaging beam-former provides the potential to have a broad and significant impact in healthcare. The instant document identifies various clinical applications of the present invention ultrasound imaging beam-forming apparatus, but should not be limited thereto, and other applications will become attained as clinicians gain access to the system and method.

15
20 [0027] The preferred embodiments of the present invention may improve significantly upon existing methods and/or apparatuses. In particular, the present invention comprises an ultrasound imaging beam-former that may be used in a hand held ultrasonic instrument such as one provided in a portable unit which performs B-mode or C-Mode imaging and/or collects three dimensional (3-D) image data.

25
30 [0028] According to some embodiments, an ultrasound imaging beam-former is provided that includes, in a first aspect of the invention, an ultrasound imaging beam-former apparatus includes a signal generator for producing an outgoing signal, a transducer for converting the outgoing signal to outgoing ultrasound and for converting at least a portion of the outgoing ultrasound that is reflected to an incoming signal, the incoming signal having a period, and a signal receiver for processing the incoming signal, the signal receiver including, an in-phase sample-

and-hold connected receivably to the transducer for sampling the incoming signal at an incoming time and outputting an in-phase amplitude of the incoming signal at substantially the incoming time, a quadrature sample-and-hold connected receivably to the transducer for sampling the incoming signal at substantially one-quarter of the period after the incoming time, the quadrature sample-and-hold outputting a quadrature amplitude of the incoming signal at substantially one-quarter of the period after the incoming time, a phase calculator connected receivably to the in-phase sample-and-hold and the quadrature sample-and-hold for receiving the incoming time, the in-phase amplitude, and the quadrature amplitude and outputting a phase, and a phase rotator for applying an illumination to the image point in substantial proportion to the phase.

[0029] In a second aspect, a method of beam-forming for ultrasound imaging includes generating an outgoing signal, transducing the outgoing signal to outgoing ultrasound, receiving at least a portion of reflected outgoing ultrasound, transducing the reflected ultrasound to an incoming signal having a period, sampling the incoming signal at an incoming time to produce an in-phase amplitude of the incoming signal, sampling the incoming signal at substantially one-quarter of the period after the incoming time to produce a quadrature amplitude of the incoming signal, calculating a phase at the incoming time based on the in-phase amplitude and the quadrature amplitude, and applying an illumination to the image point in substantial proportion to the phase.

[0030] In a third aspect, a system for beam-forming for ultrasound imaging includes means for generating an outgoing signal, means for transducing the outgoing signal to outgoing ultrasound, means for transducing at least a portion of reflected outgoing ultrasound to an incoming signal having a period, means for sampling the incoming signal at an incoming time and outputting an in-phase amplitude of the incoming signal, means for sampling the incoming signal at substantially one-quarter of the period after the incoming time and outputting a quadrature amplitude of the incoming signal, means for calculating a phase at the incoming time, based on the in-phase amplitude and the quadrature amplitude and outputting the phase, means for measuring a difference between the outgoing amplitude and the magnitude, means for applying a first illumination to a image

point in substantial proportion to the difference, and means for applying a second illumination to the image point in substantial proportion to the phase.

5 [0031] The above and/or other aspects, features and/or advantages of various embodiments will be further appreciated in view of the following description in conjunction with the accompanying figures. Various embodiments can include and/or exclude different aspects, features and/or advantages where applicable. In addition, various embodiments can combine one or more aspect or feature of other embodiments where applicable. The descriptions of aspects, features and/or advantages of particular embodiments should not be construed as limiting other
10 embodiments or the claims.

DETAILED DESCRIPTION OF THE PREFERRED EMBODIMENTS

15 [0032] The device and method for ultrasound imaging beam-forming may be utilized with various products and services as discussed below, but is not limited thereto. Technicians may attempt to insert needles into a vein based on the surface visibility of the vein coupled with their knowledge of anatomy. While this approach works quite well in thin, healthy individuals, it can prove extremely difficult in patients who may be ill or obese. It may be desirable to have a relatively small,
20 inexpensive, and portable ultrasound imaging system for guiding the insertion of intravenous (IV) devices like needles and catheters into veins, or for drawing blood.

25 [0033] Sleep apnea (obstruction of the air passage in the of the throat) may affect more than eighteen million Americans. Obstructive sleep apnea may be among the most common variants of sleep apnea. Obstructive sleep apnea may represent a significant risk to the patient. It is difficult and expensive to diagnose obstructive sleep apnea. Typical diagnostic methods require an overnight hospital stay in an instrumented laboratory. Many at-risk patients refuse this inconvenient testing regime and thus go undiagnosed. It may be desirable to have a relatively small,
30 inexpensive, and portable ultrasound imaging system to aid in the diagnosis of obstructive sleep apnea in a minimally obtrusive manner.

[0034] Manual palpation is an exceedingly common diagnostic procedure.

Clinicians use their sense of touch to feel for subcutaneous lumps or even to estimate the size of lymph nodes or other masses. While palpation undoubtedly yields valuable qualitative information, numerous studies have shown it to have extremely poor sensitivity and that quantitative size estimates may be completely unreliable. It may be desirable to have a relatively small, inexpensive, and portable ultrasound imaging system to aid in observing subcutaneous tissues.

[0035] It may be desirable to place an image display at a transducer. It may be desirable to have a relatively small, inexpensive, and portable ultrasound imaging system to aid in placing the image display at the transducer.

[0036] Ultrasound may be used to search for internal defects in metallic or ceramic parts in a broad variety of industrial applications. Current systems may be cost effective, but may be unwieldy and acquire limited data, making it difficult to ensure that a thorough search has been performed. It may be desirable to have a relatively small, inexpensive, and portable ultrasound imaging system to aid in non-destructive evaluation.

[0037] Furthermore, new users may expect ultrasound images to produce representations parallel to the skin's surface, *i.e.* C-Scan images. It would be desirable for a low cost, system to be capable of producing C-Scan images. It may further be desirable to display data in the intuitive C-scan format to allow clinicians with little or no training in reviewing ultrasound images to make use of the device.

[0038] Ultrasound imaging devices may be too expensive for some applications. It may be desirable for an ultrasound imaging device to rely primarily or exclusively on receive side beam-forming to reduce or eliminate transmit-side circuitry, enabling the beam-former to be implemented using large scale integration or as software, and enabling system to be produced at a lower cost.

[0039] It may further be desirable for an ultrasound imaging device to rely primarily or exclusively on phase rotation for focusing, enabling the beam-former to be implemented using large scale integration or as software, and enabling system to be produced at a lower cost.

[0040] Ultrasound imaging devices may be insufficiently portable for some applications. It may be desirable for an ultrasonic imaging device to be of a small size to make it easy to carry the device in a pocket or on a belt attachment. This

may make the device as convenient as a stethoscope and will thus open new applications. It may be desirable for an ultrasound imaging device to rely primarily or exclusively on receive side beam-forming to reduce or eliminate transmit-side circuitry, enabling the beam-former to be implemented using large scale integration or as software, and enabling the system to be made portable. It may further be desirable for an ultrasound imaging device to rely primarily or exclusively on phase rotation for focusing to reduce or eliminate transmit-side circuitry, enabling the beam-former to be implemented using large scale integration or as software, and enabling the system to be made portable.

[0041] Since it would be desirable for a beam-former to be simple, small, and low cost, it would be further desirable for the size and speed requirements of digital memory in such a beam-former to be minimized. It would be further desirable for focusing to be performed solely by phase rotation of I/Q data, thus eliminating the need for some circuitry, and allowing some of the remaining circuitry to be implemented as an integrated circuit. This may also allow the use of slower memory and reduce the computational complexity of the beam-former.

[0042] It would be further desirable for I/Q data to be generated by sampling an RF signal directly. In one embodiment, an analytic signal (I/Q data) is generated by sampling the received RF signal directly, in a manner analogous to the Hilbert transform. In one embodiment, focusing is implemented via phase rotation of this I/Q data.

[0043] In Fig. 1 is shown an ultrasound imaging beam-former apparatus 100 according to a first embodiment of the invention. Ultrasound imaging beam-former apparatus 100 may include a signal generator 102 for producing an outgoing signal 104 having an outgoing amplitude 106 at an outgoing time 108, as shown in Fig. 6A. In several embodiments, outgoing signal 104 may be an electrical signal, an electromagnetic signal, or an optical signal.

[0044] If outgoing signal 104 is an optical signal, cross-talk between the circuits of ultrasound imaging beam-former apparatus 100 may be reduced or eliminated, since optical signals do not, in general, interfere with one another. This may allow ultrasound imaging beam-former apparatus 100 to be made smaller than an equivalent electronic device by increasing the density of the circuits. In one case,

outgoing signal 104 may be processed as an optical signal and converted to an electrical signal to drive a transducer. An integrated circuit comprising ultrasound imaging beam-forming apparatus 100 may be implemented out of gallium-arsenide (GaAs) so that the both the optical circuits and the electrical circuits can be implemented on the same device. In another case, a transducer utilizing sonoluminescence to convert light directly into sound may be used, dispensing entirely with any need for an electrical-optical interface.

[0045] In several embodiments, signal generator 102 may be a storage device, such as a read-only memory (ROM), an oscillator such as a crystal oscillator, a resonant circuit such as a resistor-inductor-capacitor (RLC) or tank circuit, a resonant cavity such as a ruby laser or a laser diode or a tapped delay line.

[0046] In the event that signal generator 102 is a storage device, outgoing signal 104 may have been stored previously, to be read out when needed. In this embodiment, several versions of outgoing signal 104 may be stored for use with various objects 170 to be imaged. Ultrasound imaging beam-forming apparatus 100 may thus be set to produce a signal appropriate for a particular object 170 to be imaged by choosing one of the stored versions of outgoing signal 104.

[0047] In the event that signal generator 102 is an oscillator, outgoing signal 104 may be a sinusoid of varying frequencies. In this case, outgoing signal 104 may be generated at an arbitrarily high clock speed and still be forced through filters of arbitrarily small bandwidth. This may be advantageous, for example, if a wide band signal is inconvenient. A resonant circuit or a resonant cavity may work in a similar manner. Furthermore, an oscillator may be used to produce a range of frequencies, from which a frequency that generates an optimum response may be selected.

[0048] In the event that signal generator 102 is tapped delay line, outgoing signal 104 could be generated in a manner similar to a spreading code in a code division multiple access (CDMA) format cell phone system. In this case outgoing signal 104 would not need to be a pure sinusoid, but may be a code with a fixed repetition length, such as a Walsh or a Gold code. This may, for example, allow an autocorrelation length of outgoing signal 104 to be adjusted to enhance or suppress coded excitation of an incoming signal.

[0049] If signal generator 102 is a tapped delay line it may be followed by an

equalizer to bias or pre-emphasize a range of frequencies in outgoing signal 104. In one embodiment, the equalizer may be an adaptive equalizer that operates on an incoming signal analogous to the sound reflected by the imaged object 170. In this case, the incoming signal could be measured and the result applied to the adaptive
5 equalizer to compensate for frequency attenuation of the sound by amplifying one or more frequencies of the incoming signal or outgoing signal 104 as necessary. This may be useful if, for example, object 170 attenuates or absorbs sound to the point that no return signal is available for imaging. In one embodiment, the adaptive
10 equalizer could be placed in parallel with signal generator 102 and in series with the incoming signal.

[0050] In one embodiment, an equalizer could be placed in series with signal generator 102. In this case the equalizer could emphasize a particular frequency or frequencies in outgoing signal 104. The equalizer may, for example, place a bias or pre-emphasis toward lower frequencies on outgoing signal 104. This embodiment
15 may be appropriate if, for example, object 170 to be imaged is expected to have features that attenuate lower frequencies significantly more than higher frequencies to the extent that imaging may be difficult. The converse may be true as well, in that the equalizer may have a bias or pre-emphasis toward higher frequencies.

[0051] In one embodiment, outgoing signal 104 may be amplified. In one
20 embodiment, signal generator 102 may include a generator amplifier 158 for amplifying outgoing signal 104. Generator amplifier 158 may pre-emphasize certain frequencies of outgoing signal 104 to suit the attenuation characteristics of object 170 to be imaged as well. Signal generator 102 may also include an oscillator to produce an appropriate modulation frequency, such as a radio frequency (RF)
25 signal, with which to modulate outgoing signal 104.

[0052] A transducer 110 may convert outgoing signal 104 to outgoing ultrasound 112. In several embodiments, transducer 110 may be a piezoelectric element, a voice coil, a crystal oscillator or a Hall effect transducer 110. In one embodiment, reversals of outgoing signal 104 produce vibration of a surface of transducer 110 at
30 substantially the frequency of outgoing signal 104. In another embodiment, reversals of outgoing signal 104 produce vibrations of a surface of transducer 110 at frequencies that are significantly higher or lower than the frequency of outgoing

signal 104, such as harmonics of outgoing signal 104. This vibration may, in turn, produce successive compressions and rarefactions of an atmosphere surrounding the surface of transducer 110, also at substantially the frequency of outgoing signal 104. If the frequency of outgoing signal 104 is substantially higher than a frequency at which sound may be heard, the successive compressions and rarefactions of the atmosphere may be termed ultrasound.

[0053] In one embodiment, transducer 110 may include a plurality of transducers 110. In one embodiment, plurality of transducers 110 may be arranged in an array 166. In several embodiments, array 166 may be a linear array, a phased array, a curvilinear array, an unequally sampled 2-D array, a 1.5-D array, an equally sampled 2D array, a sparse 2D array, or a fully sampled 2D array.

[0054] If outgoing ultrasound 112 is reflected by object 170, some of outgoing ultrasound 112 may return to ultrasound imaging system 100 as reflected ultrasound 182. Reflected ultrasound 182 may be converted to an incoming signal 114 having a period 116, as shown in Fig. 6B. In several embodiments, incoming signal 114 may be an electro-magnetic signal, an electrical signal or an optical signal. In several embodiments, incoming signal 114 may be amplified, pre-amplified, or stored.

[0055] In one embodiment, outgoing ultrasound 112 may be delayed or attenuated partially by object 170. A first portion 174 of outgoing ultrasound 112, for example, may be reflected immediately upon encountering a nearer surface 178 of object 170 while a second portion 176 of outgoing ultrasound 112 is not reflected until it encounters a further surface 180 of object 170. A round trip of second portion 176 will thus be longer than a round trip of first portion 174, resulting in a delay of second portion 176 relative to first portion 174, as well as delays of both first and second portions 174, 176 relative to outgoing ultrasound 112. Furthermore, second portion 176 may be damped or attenuated by a material of object 170. The delays may be measured for disparate points of object 170, producing an image 168 of object 170.

[0056] Apparatus 100 may include a signal receiver 118 for processing incoming signal 114. In one embodiment, signal receiver 118 may be implemented as a digital signal processor 164. In one embodiment, signal receiver 118 may be

implemented as an integrated circuit.

[0057] Ultrasonic transducers associated with ultrasound imaging systems may be driven from a single terminal with the second terminal grounded. A transducer may be used to transmit ultrasound signals as well as receive reflected ultrasound.

5 A signal received at a transducer may typically be several orders of magnitude smaller than the signal that was transmitted due to, inter alia, signal attenuation by the target tissue. Some of the signal may be lost due to transducer inefficiencies as well. It may be thus necessary to couple the transducer to a high-voltage transmit signal while the ultrasound is being transmitted, and then to a sensitive low-noise
10 pre-amplifier while the reflected ultrasound is being received.

[0058] A switch that couples the transducer to the transmit and receive signals must be capable of withstanding high peak transmit voltages (typically 50-200 volts) while isolating the pre-amplifier input from those voltage levels, since they would otherwise destroy the pre-amplifier. If a receiver for the signals from the
15 transducers is implemented as a high-density, low-voltage integrated circuit (IC), the switches themselves may need to be implemented off-chip in a separate package from materials and devices that can withstand the high voltage transmit pulses.

[0059] In one embodiment, ultrasound imaging system 100 may include a protection circuit 172 to allow both transmit and receive operations, as shown in Fig.
20 2. A piezoelectric transducer array 202, shown on the left, acts as an interface to a signal processor by converting electrical signals to acoustic pulses and vice versa. Images may be formed by transmitting a series of acoustic pulses from the transducer array 202 and displaying signals representative of the magnitude of the echoes received from these pulses. A beam-former 214 applies delays to the
25 electrical signals to steer and focus the acoustic pulses and echoes.

[0060] Image formation begins when a state of a transmit / receive switch (TX/RX switch) 204 is altered to connect the transducer elements 202 to individual transmit circuits. Next, transmit generators 206 output time varying waveforms with delay and amplitude variations selected to produce a desired acoustic beam.
30 Voltages of up to 200 Volts may be applied to the transducer elements 202. Once transmission is complete, the state of the TX/RX switch 204 is altered again to connect the transducer elements 202 to individual receive circuitry associated with

each element.

[0061] Signals representative of incoming echoes may be amplified by pre-amplifiers 208 and time gain control (TGC) 210 circuits to compensate for signal losses due to diffraction and attenuation. Note that the transducer array 202 shown in Fig. 2 has one common electrode 212, and the non-common electrodes may be multiplexed between high-voltage transmit and low-voltage receive signals. This conventional TX/RX switch 204 is the source of considerable expense and bulk in typical ultrasound systems.

[0062] In Fig. 3 is shown an alternative ultrasound imaging beam-forming apparatus 300 with a protection circuit for use with an embodiment of the invention. Ultrasound imaging beam-forming apparatus 300 may include a signal generator 302 for producing an outgoing signal 304.

[0063] Ultrasound imaging beam-forming apparatus 300 may also include a transducer 306 for converting outgoing signal 304 to outgoing ultrasound 308 at a frequency of outgoing signal 304. In one embodiment, transducer 306 may have a transmit side 314 forming an interface with outgoing signal 304.

[0064] In one embodiment, transmit side 314 may be connected operably to a transmit switch 318. In several embodiments, transmit switch 318 may be an electronic switch, an optical switch, a micro-mechanical switch, a transistor, a field-effect transistor (FET), a bi-polar transistor, a metal-oxide-semiconductor (MOS) transistor, a complementary metal-oxide-semiconductor (CMOS) transistor, or a metal-oxide-semiconductor field-effect transistor (MOSFET). Transmit switch 318 may be connected switchably to signal generator 302 and a ground 320.

[0065] In one embodiment, transducer 306 may convert at least a portion of reflected ultrasound 310 to an incoming signal 312. In several embodiments, incoming signal 312 may be an electro-magnetic signal, an electrical signal, or an optical signal. In one embodiment, transducer 306 may have a receive side 316 forming an interface with incoming signal 312.

[0066] In one embodiment, receive side 316 may be connected operably to a receive switch 322. In several embodiments, receive switch 322 may be an electronic switch, an optical switch, a micro-mechanical switch, a transistor, a field-effect transistor, a bi-polar transistor, a MOS transistor, a CMOS transistor, or a

MOSFET transistor. Receive switch 322 may be connected switchably to a signal receiver 324 and ground 320.

5 [0067] In one embodiment, transmit switch 318 may connect transmit side 314 to signal generator 302 for a first predetermined period of time while signal generator 302 generates outgoing signal 304. In this embodiment, receive switch 322 may connect receive side 316 to signal receiver 324 for a second predetermined period of time while signal receiver 324 receives incoming signal 312. Transmit switch 318 may connect transmit side 314 to ground 320 during substantially second
10 predetermined period of time while signal receiver 324 receives incoming signal 312, and receive switch 322 may connect receive side 316 to ground 320 during substantially first predetermined period of time while signal generator 302 generates outgoing signal 304. In one embodiment, transmit side 314 and receive side 316 are on separate transducers 306.

15 [0068] In one embodiment, signal receiver 118 may include a receiver amplifier 160 for amplifying incoming signal 114. In one embodiment, signal receiver 118 may include a receiver pre-amplifier 162 for amplifying incoming signal 114. In one embodiment, signal receiver 118 may include a band-pass filter 164 for filtering incoming signal 114.

20 [0069] In one embodiment, signal receiver 118 may include an in-phase sample-and-hold 120 connected receivably to transducer 110 for sampling incoming signal 114 at an incoming time 122 and outputting an in-phase amplitude 124 of incoming signal 114 at substantially incoming time 122. In one embodiment, signal receiver 118 may include an in-phase analog-to-digital converter 126 connected receivably to in-phase sample-and-hold 120 for assigning an in-phase digital value 128 to in-phase amplitude 124 and outputting in-phase digital value 128.
25

30 [0070] In one embodiment, signal receiver 118 may include a quadrature sample-and-hold 130 connected receivably to transducer 110 for sampling incoming signal 114 at substantially one-quarter of period 116 after incoming time 122, quadrature sample-and-hold 130 outputting a quadrature amplitude 132 of incoming signal 114 at substantially one-quarter of period 116 after incoming time 122. One-quarter of period 116 is merely exemplary. Incoming signal 114 may be sampled at any appropriate interval or fraction of period 116. In one embodiment, signal receiver

118 may include a quadrature analog-to-digital converter 134 connected receivably to quadrature sample-and-hold 130 for assigning a quadrature digital value 136 to quadrature amplitude 132 and outputting quadrature digital value 136.

[0071] In one embodiment, signal receiver 118 may include a magnitude calculator 138 connected receivably to in-phase analog-to-digital converter 126 and quadrature analog-to-digital converter 134 for receiving incoming time 122, in-phase digital value 128, and quadrature digital value 136 and outputting a magnitude 140.

In one embodiment, signal receiver 118 may include a phase calculator 142 connected receivably to in-phase analog-to-digital converter 126 and quadrature analog-to-digital converter 134 for receiving incoming time 122, in-phase digital value 128, and quadrature digital value 136 and outputting a phase 144.

[0072] In one embodiment, incoming signal 114 may be band-pass filtered by band-pass filter 164 and diverted to in-phase sample-and-hold 120 and quadrature sample-and-hold 130. An in-phase clock signal 184 driving in-phase sample-and-hold 120 may be of the same frequency as a quadrature clock signal 186 driving quadrature sample-and-hold 130. Quadrature clock signal 186 may, however, be offset by a quarter of period 116 with respect to in-phase clock signal 184 at an assumed center frequency of incoming signal 114. An output of in-phase sample-and-hold 120 may be digitized by in-phase analog-to-digital converter 126 while an output of quadrature sample-and-hold 130 is digitized in quadrature analog-to-digital converter 134, forming I and Q channel data.

[0073] Reflected ultrasound 182 may be considered to be real part of an amplitude and phase modulated complex exponential signal, or analytic signal. The modulating signal may be expressed mathematically as $A(t)e^{j\phi(t)}$ with instantaneous amplitude $A(t)$ and phase $\phi(t)$. This is superimposed on a carrier signal $e^{-j\omega_0 t}$, where $\omega_0 = 2\pi f_0$ and f_0 is the frequency of the signal. Therefore the analytic signal $S(t)$ can be written as,

$$\begin{aligned} S(t) &= A(t)e^{-j(\omega_0 t - \phi(t))} \\ &= A(t)\cos(\omega_0 t - \phi(t)) - jA(t)\sin(\omega_0 t - \phi(t)) \end{aligned} \quad (1)$$

[0074] Only the real part of $S(t)$, which is equivalent to reflected ultrasound 182,

is able to be acquired experimentally.

$$I(t) = \text{Re}\{S(t)\} = A(t) \cos(\omega_0 t - \phi(t)) \quad (2)$$

[0075] The output of in-phase analog-to-digital converter 126 is the signal in equation 2 after sampling, or

$$5 \quad \hat{I}(nT) = I(nT) = A(nT) \cos(\omega_0 nT - \phi(nT)), n = 0, 1, 2, 3, \dots \quad (3)$$

where T is the sample interval. However, we also require the imaginary component of $S(t)$, shown below in equation 4, to perform beam-forming.

$$Q(t) = \text{Im}\{S(t)\} = -A(t) \sin(\omega_0 t - \phi(t)) \quad (4)$$

10 [0076] Quadrature clock signal 186 has a time lag of a quarter period at the assumed center frequency relative to the in-phase clock signal 184, as shown schematically in Fig. 7. Therefore the relative time lag is $\frac{1}{4f_0}$, or $\frac{\pi}{2\omega_0}$.

[0077] The output of quadrature sample-and-hold 130 is,

$$\begin{aligned} \hat{Q}(nT) &= I\left\{nT + \frac{\pi}{2\omega_0}\right\} \\ &= A\left(nT + \frac{\pi}{2\omega_0}\right) \cos\left(\omega_0\left(nT + \frac{\pi}{2\omega_0}\right) - \phi\left(nT + \frac{\pi}{2\omega_0}\right)\right) \end{aligned} \quad (5)$$

15 [0078] We assume that the modulating signal $A(t)e^{j\phi(t)}$ varies slowly with time and approximate,

$$A\left(nT + \frac{\pi}{2\omega_0}\right) \approx A(nT) \quad (6)$$

and

$$\phi\left(nT + \frac{\pi}{2\omega_0}\right) \approx \phi(nT) \quad (7)$$

[0079] Equation 5 can now be rewritten as follows.

$$\begin{aligned}
\hat{Q}(nT) &\approx A(nT) \cos\left(\omega_0\left(nT + \frac{\pi}{2\omega_0}\right) - \phi(nT)\right), n = 0,1,2,3\dots \\
&\approx -A(nT) \sin(\omega_0 nT - \phi(nT)) \\
&\approx Q(nT)
\end{aligned}
\tag{8}$$

[0080] We therefore approximate the imaginary component of $S(t)$, or $Q(t)$ in equation 4, by estimating it to be the output of quadrature sample-and-hold 130.

[0081] Geometric time delays may be calculated and converted to phase delays at the assumed center frequency. Complex weights that implement apodization and focus with the calculated phase delays may be applied to the I/Q data. In one embodiment, signal receiver 118 may include an apodizer 146 for applying a difference 148 between outgoing amplitude 106 and magnitude 140 and applying a first illumination 150-1 to an image points 154 in substantial proportion to difference 148. In one embodiment, signal receiver 118 may include a phase rotator 152 for applying a second illumination 150-2 to image point 154 in substantial proportion to phase 144.

[0082] In a second embodiment of the invention, shown in Fig. 4, apparatus 100 may include a second transducer 110-2 for converting outgoing signal 104 to second outgoing ultrasound 112-2. Some of second outgoing ultrasound 112-2 may return to second transducer 110-2 if it is reflected by object 170 as well. Second transducer 110-2 may convert at least a portion of outgoing ultrasound 112 and second outgoing ultrasound 112-2 to a second incoming signal 114-2 having a second period 116-2, as shown in Fig. 6C.

[0083] In one embodiment, signal receiver 118 may include a second in-phase sample-and-hold 120-2 connected receivably to second transducer 110-2 for sampling second incoming signal 114-2 at incoming time 122 and outputting a second in-phase amplitude 124-2 of second incoming signal 114-2 at substantially incoming time 122. In one embodiment, signal receiver 118 may include a second in-phase analog-to-digital converter 126-2 connected receivably to second in-phase sample-and-hold 120-2 for assigning a second in-phase digital value 128-2 to second in-phase amplitude 124-2 and outputting second in-phase digital value 128-

2.

[0084] In one embodiment, signal receiver 118 may include a second quadrature sample-and-hold 130-2 connected receivably to second transducer 110-2 for sampling second incoming signal 114-2 at substantially one-quarter of second period 116-2 after incoming time 122, second quadrature sample-and-hold 130-2 outputting a second quadrature amplitude 132-2 of second incoming signal 114-2 at substantially one-quarter of second period 116-2 after incoming time 122. In one embodiment, signal receiver 118 may include a second quadrature analog-to-digital converter 134-2 connected receivably to second quadrature sample-and-hold 130-2 for assigning a second quadrature digital value 136-2 to second quadrature amplitude 132-2 and outputting second quadrature digital value 136-2.

[0085] In one embodiment, signal receiver 118 may include a second magnitude calculator 138-2 connected receivably to second in-phase analog-to-digital converter 126-2 and second quadrature analog-to-digital converter 134-2 for receiving incoming time 122, second in-phase digital value 128-2, and second quadrature digital value 136-2 and outputting a second magnitude 140-2. In one embodiment, signal receiver 118 may include a second phase calculator 142-2 connected receivably to second in-phase analog-to-digital converter 126-2 and second quadrature analog-to-digital converter 134-2 for receiving incoming time 122, second in-phase digital value 128-2, and second quadrature digital value 136-2 and outputting a second phase 144-2.

[0086] In one embodiment, signal receiver 118 may include a second apodizer 146-2 for applying a second difference 148-2 between outgoing amplitude 106 and second magnitude 140-2 and applying a third illumination 150-3 to an image point 154 in substantial proportion to second difference 148-2. In one embodiment, signal receiver 118 may include a second phase rotator 152-2 for applying a fourth illumination 150-4 to image point 154 in substantial proportion to second phase 144-2. In one embodiment, signal receiver 118 may include a summer 156 for combining difference 148, second difference 148-2, phase 144, and second phase 144-2 before first, second, third, and fourth illuminations 150-1 - 150-4 are applied to image point 154.

[0087] In a third embodiment, a method of beam-forming for ultrasound imaging

may include the steps of generating an outgoing signal 104 having an outgoing amplitude 106 at an outgoing time 108, transducing outgoing signal 104 to outgoing ultrasound 112, receiving at least a portion of reflected outgoing ultrasound 112, transducing reflected ultrasound to an incoming signal 114 having a period 116, sampling incoming signal 114 at an incoming time 122 to produce an in-phase amplitude 124 of incoming signal 114, assigning an in-phase digital value 128 to in-phase amplitude 124 sampling incoming signal 114 at substantially one-quarter of period 116 after incoming time 122 to produce a quadrature amplitude 132 of incoming signal 114, assigning a quadrature digital value 136 to quadrature amplitude 132, calculating a magnitude 140 at incoming time 122 based on in-phase digital value 128 and quadrature digital value 136, calculating a phase 144 at incoming time 122 based on in-phase digital value 128 and quadrature digital value 136, measuring a difference 148 between outgoing amplitude 106 and magnitude 140, applying a first illumination 150-1 to an image point 154 in substantial proportion to difference 148, and applying a second illumination 150-2 to image point 154 in substantial proportion to phase 144.

[0088] In one embodiment, the method of beam-forming for ultrasound imaging may further include the steps of transducing outgoing signal 104 to second outgoing ultrasound 112-2, receiving at least a portion of reflected outgoing ultrasound 112 and second outgoing ultrasound 112-2, transducing reflected outgoing ultrasound 112 and second outgoing ultrasound 112-2 to a second incoming signal 114-2 having a second period 116-2, sampling second incoming signal 114-2 at incoming time 122 to produce a second in-phase amplitude 124-2 of second incoming signal 114-2, assigning a second in-phase digital value 128-2 to second in-phase amplitude 124-2, sampling second incoming signal 114-2 at substantially one-quarter of second period 116-2 after incoming time 122 to produce a second quadrature amplitude 122-2 of second incoming signal 114-2, assigning a second quadrature digital value 136-2 to second quadrature amplitude 122-2, calculating a second magnitude 140-2 at incoming time 122 based on second in-phase digital value 128-2 and second quadrature digital value 136-2, calculating a second phase 144-2 at incoming time 122 based on second in-phase digital value 128-2 and second quadrature digital value 136-2, measuring a second difference 148-2

between outgoing amplitude 106 and second magnitude 140-2, summing difference 148, second difference 148-2, phase 144, and second phase 144-2, applying a third illumination 150-3 to image point 154 in substantial proportion to second difference 148-2, and applying a fourth illumination 150-4 to image point 154 in substantial
5 proportion to second phase 144-2.

[0089] In one embodiment, the method of beam-forming may be repeated to produce a plurality of image points 154 forming an image 168. In several
embodiments, image 168 may be viewed, used to guide insertion of a needle, used
to guide insertion of a catheter, used to guide insertion of an endoscope, used to
10 estimate blood flow, or used to estimate tissue motion. In one embodiment, plurality
of image points 154 may be focused. In one embodiment, focusing may be
repeated on reflected outgoing ultrasound 112 at plurality of image points 154.

[0090] In one embodiment, plurality of image points 154 may be along a line at a
range of interest. In one embodiment, a line may be formed at a plurality of ranges
15 to form a planar image. In one embodiment, the planar image may be a B-mode
image. In one embodiment, plurality of image points 154 may lie within a plane at a
range of interest. In one embodiment, plurality of image points 154 may form a C-
scan. In one embodiment, the plane may be formed at multiple ranges. In one
embodiment, several planes may form a complex 1-D image.

[0091] In one embodiment, an envelope of magnitude 140 may be displayed. In
20 one embodiment, phase 144 may be used to compensate for a path difference 148
between various transducers and object 170. In one embodiment, a main lobe
resolution and a side lobe level may be balanced based on magnitude 140. In one
embodiment, a sum squared error between a desired system response and a true
25 system response may be minimized.

[0092] One skilled in the art would appreciate that a variety of tissue information
may be obtained through judicious pulse transmission and signal processing of
received echoes with the current invention. Such information could be displayed in
conjunction with or instead of the aforementioned echo information.

[0093] One such type of information is referred to as color flow Doppler as
30 described in U.S. Patent No. 4,573,477 to Namekawa et al., entitled "Ultrasonic
Diagnostic Apparatus," hereby incorporated by reference herein in its entirety.

Another useful type of information is harmonic image data as described in U.S. Patent No. 6,251,074 to Averkiou et al., entitled "Ultrasonic Tissue Harmonic Imaging" and U.S. Patent no. 5,632,277 to Chapman et al., entitled "Ultrasound Imaging System Employing Phase Inversion Subtraction to Enhance the Image," both of which are hereby incorporated by reference herein in their entirety. Yet another type of information that may be obtained and displayed is known as Power Doppler as described in U.S. Patent No. 5,471,990 to Thirsk, entitled "Ultrasonic Doppler Power Measurement and Display System, " hereby incorporated by reference herein in its entirety.

[0094] Angular scatter information might also be acquired using a method described in a co-pending U.S. Patent Application No. 10/030,958, entitled "Angular Scatter Imaging System Using Translating Apertures Algorithm and Method Thereof," filed June 3, 2002, of which is hereby incorporated by reference herein in its entirety.

Speckle is a common feature of ultrasound images. While it is fundamental to the imaging process, many users find its appearance confusing and it has been shown to limit target detectability. A variety of so called compounding techniques have been described which could be valuable for reducing the appearance of speckle in ultrasound transducer drive images. These techniques include spatial compounding and frequency compounding, both of which are well described in the literature.

[0095] One skilled in the art would appreciate that the common practice of frequency compounding could be readily applied to the current invention. By transmitting a plurality of pulses at different frequencies and forming separate detected images using the pulses one may obtain multiple unique speckle patterns from the same target. These patterns may then be averaged to reduce the overall appearance of speckle.

[0096] The well known techniques of spatial compounding may also be applied to the current invention. The most conventional form of spatial compounding, which we call two-way or transmit-receive spatial compounding, entails the acquisition of multiple images with the active transmit and receive apertures shifted spatially between image acquisitions. This shifting operation causes the speckle patterns obtained to differ from one image to the next, enabling image averaging to reduce

the speckle pattern.

[0097] In another technique, which we term one-way or receive-only spatial compounding, the transmit aperture is held constant between image acquisitions while the receive aperture is shifted between image acquisitions. As with two-way spatial compounding, this technique reduces the appearance of speckle in the final image.

[0098] In many ultrasound applications the received echoes from tissue have very small amplitude, resulting in an image with poor signal to noise ratio. This problem may be addressed through the use of a technique known as coded excitation. In this method the transmitted pulse is long in time and designed so that it has a very short auto-correlation length. In this manner the pulse is transmitted and received signals are correlated with the transmitted pulse to yield a resultant signal with good signal to noise ratio, but high axial resolution (short correlation length). This method could be readily applied in the present invention ultrasound transducer drive device and method to improve the effective signal to noise ratio. The coded excitation technique is described in U.S. Patent No. 5,014,712 to O'Donnell, entitled "Coded Excitation for Transmission Dynamic Focusing of Vibratory Energy Beam," hereby incorporated by reference herein in its entirety.

[0099] An aspect in fabricating a system like the present invention ultrasound imaging beam-forming apparatus is in construction of the transducer array. Both cost and complexity could be reduced by incorporating a transducer implemented using photolithographic techniques, i.e. the transducer is formed using micro electro mechanical systems (MEMS). One particularly attractive approach has been described in U.S. Patent No. 6,262,946 to Khuri-Yakub et al., entitled "Capacitive Micromachined Ultrasonic Transducer Arrays with Reduced Cross-Coupling," hereby incorporated by reference herein in its entirety.

[0100] While the present invention may be embodied in many different forms, a number of illustrative embodiments are described herein with the understanding that the present disclosure is to be considered as providing examples of the principles of the invention and such examples are not intended to limit the invention to preferred embodiments described herein and/or illustrated herein.

Broad Scope of the Invention:

[0101] While illustrative embodiments of the invention have been described herein, the present invention is not limited to the various preferred embodiments described herein, but includes any and all embodiments having equivalent elements, modifications, omissions, combinations (e.g., of aspects across various
5 embodiments), adaptations and/or alterations as would be appreciated by those in the art based on the present disclosure. The limitations in the claims are to be interpreted broadly based on the language employed in the claims and not limited to examples described in the present specification or during the prosecution of the application, which examples are to be construed as non-exclusive. For example, in
10 the present disclosure, the term "preferably" is non-exclusive and means "preferably, but not limited to." In this disclosure and during the prosecution of this application, means-plus-function or step-plus-function limitations will only be employed where for a specific claim limitation all of the following conditions are present in that limitation: a) "means for" or "step for" is expressly recited; b) a
15 corresponding function is expressly recited; and c) structure, material or acts that support that structure are not recited. In this disclosure and during the prosecution of this application, the terminology "present invention" or "invention" may be used as a reference to one or more aspect within the present disclosure. The language
20 present invention or invention should not be improperly interpreted as an identification of criticality, should not be improperly interpreted as applying across all aspects or embodiments (i.e., it should be understood that the present invention has a number of aspects and embodiments), and should not be improperly interpreted as limiting the scope of the application or claims. In this disclosure and during the
25 prosecution of this application, the terminology "embodiment" can be used to describe any aspect, feature, process or step, any combination thereof, and/or any portion thereof, etc. In some examples, various embodiments may include overlapping features. In this disclosure, the following abbreviated terminology may be employed: "e.g." which means "for example;" and "NB" which means "note well."

What is claimed is:

1. An ultrasound imaging beam-former apparatus, comprising:
 - a signal generator for producing an outgoing signal;
 - a transducer for converting said outgoing signal to outgoing ultrasound and for converting at least a portion of said outgoing ultrasound that is reflected to an incoming signal, said incoming signal having a period; and
 - a signal receiver for processing said incoming signal, said signal receiver comprising:
 - an in-phase sample-and-hold connected receivably to said transducer for sampling said incoming signal at an incoming time and outputting an in-phase amplitude of said incoming signal at substantially said incoming time;
 - a quadrature sample-and-hold connected receivably to said transducer for sampling said incoming signal at substantially one-quarter of said period after said incoming time, said quadrature sample-and-hold outputting a quadrature amplitude of said incoming signal at substantially one-quarter of said period after said incoming time;
 - a phase calculator connected receivably to said in-phase sample-and-hold and said quadrature sample-and-hold for receiving said incoming time, said in-phase amplitude, and said quadrature amplitude and outputting a phase; and
 - a phase rotator for applying an illumination to said image point in substantial proportion to said phase.
2. The ultrasound imaging beam-former apparatus of claim 1, comprising further:
 - an in-phase analog-to-digital converter connected receivably to said in-phase sample-and-hold for assigning an in-phase digital value to said in-phase amplitude and outputting said in-phase digital value.
3. The ultrasound imaging beam-former apparatus of claim 1, comprising further:
 - a quadrature analog-to-digital converter connected receivably to said quadrature sample-and-hold for assigning a quadrature digital value to said quadrature amplitude and outputting said quadrature digital value.
4. The ultrasound imaging beam-former apparatus of claim 1, wherein signal

has an outgoing amplitude;

a magnitude calculator connected receivably to said in-phase analog-to-digital converter and said quadrature analog-to-digital converter for receiving said incoming time, said in-phase digital value, and said quadrature digital value and outputting a magnitude; and

an apodizer for applying a difference between an outgoing amplitude of said outgoing signal at an outgoing time and said magnitude and applying a second illumination to a image point in substantial proportion to said difference.

5. The ultrasound imaging beam-former apparatus of claim 1, comprising further:

a second transducer for converting said outgoing signal to second outgoing ultrasound and for converting at least a portion of said outgoing ultrasound and said second outgoing ultrasound that is reflected to a second incoming signal, said second incoming signal having a second period; and

a second signal receiver for processing said second incoming signal, said second signal receiver comprising:

a second in-phase sample-and-hold connected receivably to said second transducer for sampling said second incoming signal at a second incoming time and outputting a second in-phase amplitude of said second incoming signal at substantially said second incoming time;

a second quadrature sample-and-hold connected receivably to said second transducer for sampling said second incoming signal at substantially one-quarter of said second period after said second incoming time, said second quadrature sample-and-hold outputting a second quadrature amplitude of said second incoming signal at substantially one-quarter of said second period after said second incoming time;

a second phase calculator connected receivably to said second in-phase sample-and-hold and said second quadrature sample-and-hold for receiving said second incoming time, said second in-phase amplitude, and said second quadrature amplitude and outputting a second phase; and

a second phase rotator for applying a second illumination to said second image point in substantial proportion to said second phase; and

a summer for combining said difference, said second difference, said phase, and said second phase before said illumination and said second illumination are applied to said image point.

6. The ultrasound imaging beam-former apparatus of claim 1, wherein said signal generator comprises further a generator amplifier for amplifying said outgoing signal.

7. The ultrasound imaging beam-former apparatus of claim 1, wherein said signal receiver comprises further a receiver amplifier for amplifying said incoming signal.

8. The ultrasound imaging beam-former apparatus of claim 1, wherein said signal receiver comprises further a receiver pre-amplifier for amplifying said incoming signal.

9. The ultrasound imaging beam-former apparatus of claim 1, wherein said signal receiver comprises further a band-pass filter for filtering said incoming signal.

10. The ultrasonic imaging beam-former apparatus of claim 1, wherein said signal receiver comprises a digital signal processor.

11. The ultrasonic imaging beam-former apparatus of claim 1, wherein said outgoing signal is selected from the group consisting of:

- an electro-magnetic signal,
- an electrical signal, and
- an optical signal.

12. The ultrasonic imaging beam-former apparatus of claim 1, wherein said incoming signal is selected from the group consisting of:

- an electro-magnetic signal,
- an electrical signal, and
- an optical signal.

13. The ultrasonic imaging beam-former apparatus of claim 1, wherein said transducer is selected from the group consisting of:

- a piezoelectric element,
- a voice coil,
- a MEMS device,
- a capacitive micro-machined transducer,

a crystal oscillator, and
a Hall effect transducer.

14. The ultrasonic imaging beam-former apparatus of claim 1, wherein said signal receiver is implemented as an integrated circuit.

15. The ultrasonic imaging beam-former apparatus of claim 1, wherein the transducer comprises further a plurality of transducers.

16. The ultrasonic imaging beam-former apparatus of claim 12, wherein said plurality of transducers forms an array selected from the group consisting of:

a linear array,
a phased array
a curvilinear array,
an unequally sampled 2-D array,
a 1.5-D array,
a catheter based array,
an intra-cavity array,
an equally sampled 2D,
a sparse 2D array, and
fully sampled 2D array.

17. The ultrasonic imaging beam-former apparatus of claim 1, comprising further a protection circuit to allow both transmit and receive operations.

18. A method of beam-forming for ultrasound imaging, comprising:
generating an outgoing signal;
transducing said outgoing signal to outgoing ultrasound;
receiving at least a portion of reflected outgoing ultrasound;
transducing said reflected ultrasound to an incoming signal having a period;
sampling said incoming signal at an incoming time to produce an in-phase amplitude of said incoming signal;

sampling said incoming signal at substantially one-quarter of said period after said incoming time to produce a quadrature amplitude of said incoming signal;

calculating a phase at said incoming time based on said in-phase amplitude and said quadrature amplitude; and

applying a illumination to an image point in substantial proportion to said

phase.

19. The method of beam-forming for ultrasound imaging of claim 18, comprising further:

assigning an in-phase digital value to said in-phase amplitude.

20. The method of beam-forming for ultrasound imaging of claim 18, comprising further:

assigning a quadrature digital value to said quadrature amplitude.

21. The method of beam-forming for ultrasound imaging of claim 18, comprising further:

calculating a magnitude at said incoming time, based on said in-phase amplitude and said quadrature amplitude;

measuring a difference between an outgoing amplitude of said outgoing signal and said magnitude; and

applying a second illumination to said image point in substantial proportion to said difference.

22. The method of beam-forming for ultrasound imaging of claim 18, comprising further:

transducing said outgoing signal to second outgoing ultrasound;

receiving at least a portion of reflected outgoing ultrasound and second outgoing ultrasound;

transducing said reflected outgoing ultrasound and second outgoing ultrasound to a second incoming signal having a second period;

sampling said second incoming signal at said incoming time to produce a second in-phase amplitude of said second incoming signal;

sampling said second incoming signal at substantially one-quarter of said second period after said incoming time to produce a second quadrature amplitude of said second incoming signal;

calculating a second phase at said incoming time based on said second in-phase amplitude and said second quadrature amplitude;

summing said phase and said second phase; and

applying a second illumination to said image point in substantial proportion to said second phase.

23. The method of beam-forming for ultrasound imaging of claim 18, comprising further amplifying said outgoing signal.

24. The method of beam-forming for ultrasound imaging of claim 18, comprising further an operation selected from the group consisting of:

amplifying said incoming signal,
pre-amplifying said incoming signal, and
storing said incoming signal.

25. The method of beam-forming for ultrasound imaging of claim 18, comprising further repeating the method of beam-forming to produce a plurality of image points forming an image.

26. The method of beam-forming for ultrasound imaging of claim 25, comprising further an operation selected from the group consisting of:

viewing said image,
guiding insertion of a needle based on said image,
guiding insertion of a catheter based on said image,
guiding insertion of an endoscope based on said image,
estimating blood flow based on said image, and
estimating tissue motion based on said image.

27. The method of beam-forming for ultrasound imaging of claim 25, further comprising focusing said plurality of image points.

28. The method of beam-forming for ultrasound imaging of claim 25, wherein said focusing is repeated on said reflected outgoing ultrasound at said plurality of image points.

29. The method of beam-forming for ultrasound imaging of claim 25, wherein the plurality of image points are along a line at a range of interest.

30. The method of beam-forming for ultrasound imaging of claim 29, wherein the line is formed at a plurality of ranges to form a planar image.

31. The method of beam-forming for ultrasound imaging of claim 30, wherein the planar image is a B-mode image.

32. The method of beam-forming for ultrasound imaging of claim 25, wherein the plurality of image points lie within a plane at a range of interest.

33. The method of beam-forming for ultrasound imaging of claim 32, wherein

the plurality of image points form a C-scan.

34. The method of beam-forming for ultrasound imaging of claim 32, wherein the plane is formed at multiple ranges.

35. The method of beam-forming for ultrasound imaging of claim 32, wherein the planes form a complex 3D image.

36. The method of beam-forming for ultrasound imaging of claim 18, wherein an envelope of the magnitude is displayed.

37. The method of beam-forming for ultrasound imaging of claim 18, further comprising compensating for a path difference based on the phase.

38. The method of beam-forming for ultrasound imaging of claim 18, wherein a main lobe resolution and a side lobe level is balanced based on the magnitude.

39. The method of beam-forming for ultrasound imaging of claim 18, wherein a sum squared error between a desired system response and a true system response is minimized.

40. A system for beam-forming for ultrasound imaging, comprising:
means for generating an outgoing signal having an outgoing amplitude at an outgoing time;
means for transducing said outgoing signal to outgoing ultrasound;
means for transducing at least a portion of reflected outgoing ultrasound to an incoming signal having a period;
means for sampling said incoming signal at an incoming time and outputting an in-phase amplitude of said incoming signal;
means for sampling said incoming signal at substantially one-quarter of said period after said incoming time and outputting a quadrature amplitude of said incoming signal;
means for calculating a phase at said incoming time, based on said in-phase amplitude and said quadrature amplitude and outputting said phase;
and
means for applying a second illumination to said image point in substantial proportion to said phase.
means for calculating a magnitude at said incoming time, based on said in-phase amplitude and said quadrature amplitude and outputting said magnitude;

means for measuring a difference between an outgoing amplitude of said outgoing signal and said magnitude; and

means for applying a first illumination to a image point in substantial proportion to said difference.

41. The system for beam-forming for ultrasound imaging of claim 40, comprising further:

second means for transducing said outgoing signal to second outgoing ultrasound;

second means for transducing said reflected outgoing ultrasound and second outgoing ultrasound to a second incoming signal having a second period;

second means for sampling said second incoming signal at said incoming time and outputting a second in-phase amplitude of said second incoming signal;

second means for sampling said second incoming signal at substantially one-quarter of said second period after said incoming time and outputting a second quadrature amplitude of said second incoming signal;

second means for calculating a second phase at said incoming time based on said second in-phase amplitude and said second quadrature amplitude and outputting said second phase;

second means for summing said difference, said second difference, said phase, and said second phase; and

second means for applying a fourth illumination to said image point in substantial proportion to said second phase.

42. The system for beam-forming for ultrasound imaging of claim 40, comprising further means for amplifying said outgoing signal.

43. The system for beam-forming for ultrasound imaging of claim 40, comprising further means for amplifying said incoming signal.

44. The system for beam-forming for ultrasound imaging of claim 40, comprising further means for pre-amplifying said incoming signal.

45. The system for beam-forming for ultrasound imaging of claim 40, comprising further means for storing said incoming signal.

46. The system for beam-forming for ultrasound imaging of claim 40, comprising further means for viewing an image comprising said image point.

47. The system for beam-forming for ultrasound imaging of claim 40, comprising further means for guiding insertion of a needle, a catheter, or an endoscope based on an image comprising said image point.

48. An ultrasound beamformer apparatus, comprising:

a signal generator for producing an outgoing signal having an outgoing amplitude at an outgoing time;

a transducer for converting said outgoing signal to outgoing ultrasound;

a plurality of transducers for converting at least a portion of said outgoing ultrasound that is reflected to incoming signals, said incoming signals having oscillations in time;

a plurality of signal receivers for converting each of said incoming signals to a pair, or time series of pairs of in phase and quadrature samples;

a focusing apparatus for combining said in phase and quadrature samples to yield a focused in phase / quadrature sample.

49. The ultrasound beamformer apparatus of claim 48, wherein:

complex demodulated echo data obtained from a single range from each transducer array element are sampled;

complex echo signals are multiplied by complex weightings; and

the results are summed to focus at a specific point at the range of interest.

50. The ultrasound beamformer apparatus of claim 48, wherein:

the complex demodulation is performed using an analog demodulation circuit on each element.

51. The ultrasound beamformer apparatus of claim 48, wherein:

the complex demodulation is performed by sampling the incoming signal at two points separated in time by approximately 1/4 of a period.

52. The ultrasound beamformer apparatus of claim 48, wherein:

the complex demodulation is performed via digital means.

53. The ultrasound beamformer apparatus of claim 48, wherein:

the focusing operation is repeated on the same set of echo data at a plurality of points to form complex image data at that range.

54. The ultrasound beamformer apparatus of claim 53, wherein:

the plurality of image points are along a line at the range of interest.

55. The ultrasound beamformer apparatus of claim 53, wherein:
the plurality of image points lie within a plane at the range of interest and
thereby form a complex c-scan.

56. The ultrasound beamformer apparatus of claim 53, wherein:
the process of forming image lines is repeated at numerous ranges to form a
planar ultrasound image, possibly being a b-mode image.

57. The ultrasound beamformer apparatus of claim 53, wherein:
the process of forming image planes is repeated at multiple ranges to form a
complex 3D image.

58. The ultrasound beamformer apparatus of claim 48, wherein:
the envelope of the magnitude of the complex image is taken for display to
the user.

59. The ultrasound beamformer apparatus of claim 48, wherein:
the phases of the complex weightings used for focusing are determined so as
to compensate for path length differences between different transducer array
elements and the focal point.

60. The ultrasound beamformer apparatus of claim 48, wherein:
the magnitude of applied complex weightings are selected to maintain a
reasonable balance between main-lobe resolution and side-lobe levels in the
system response.

61. The ultrasound beamformer apparatus of claim 48, wherein:
the complex weightings used for focusing are determined so as to minimize
the sum squared error between some desired system response and the true system
response following the method described by Ranganathan and Walker in "A Novel
Beamformer Design Method for Medical Ultrasound: Part I: Theory" a paper in press
for IEEE Trans. Ultrason. Ferroelec. Freq. Contr.

62. The ultrasound beamformer apparatus of claim 48, wherein:
the transducer array employed for imaging consists of a plurality of array
elements transducer elements placing in a linear configuration selected from the
group consisting of:

a linear array,

a phased array, and

a curvilinear array.

63. The ultrasound beamformer apparatus of claim 48, wherein:
the transducer array employed for imaging consists of a plurality of elements arranged in an unequally sampled 2D configuration or a 1.5-D array.

64. The ultrasound beamformer apparatus of claim 48, wherein:
the transducer array employed for imaging consists of a plurality of elements that are placed in an equally sampled 2D configuration.

65. The ultrasound beamformer apparatus of claim 64, wherein a fraction of the elements of the array are utilized such that the resulting array is a sparse 2D array.

66. The ultrasound beamformer apparatus of claim 64, wherein:
all elements of the array are utilized such that the resulting array is a fully sampled 2D array.

67. The ultrasound beamformer apparatus of claim 48, wherein:
connections are made to individual array elements such that individual elements may be used for either transmission or reception, but not both, thereby eliminating the need for receive protection circuitry.

68. The ultrasound beamformer apparatus of claim 48, wherein:
only a fraction of elements are used to form any given image point.

69. The ultrasound beamformer apparatus of claim 48, wherein:
the focusing operation is repeated for different fractions of the aperture thereby obtaining multiple redundant views of the same target location.

70. The ultrasound beamformer apparatus of claim 48, wherein:
the multiple looks are averaged after taking their magnitudes so as to reduce the appearance of speckle in the resulting image.

71. The ultrasound beamformer apparatus of claim 48, wherein: the complex image points are used over successive acquisitions to estimate blood flow or tissue motion.

72. The ultrasound beamformer apparatus of claim 48, wherein: the sampling operation is performed at multiple ranges for a single transmit event, thereby increasing the image formation rate.

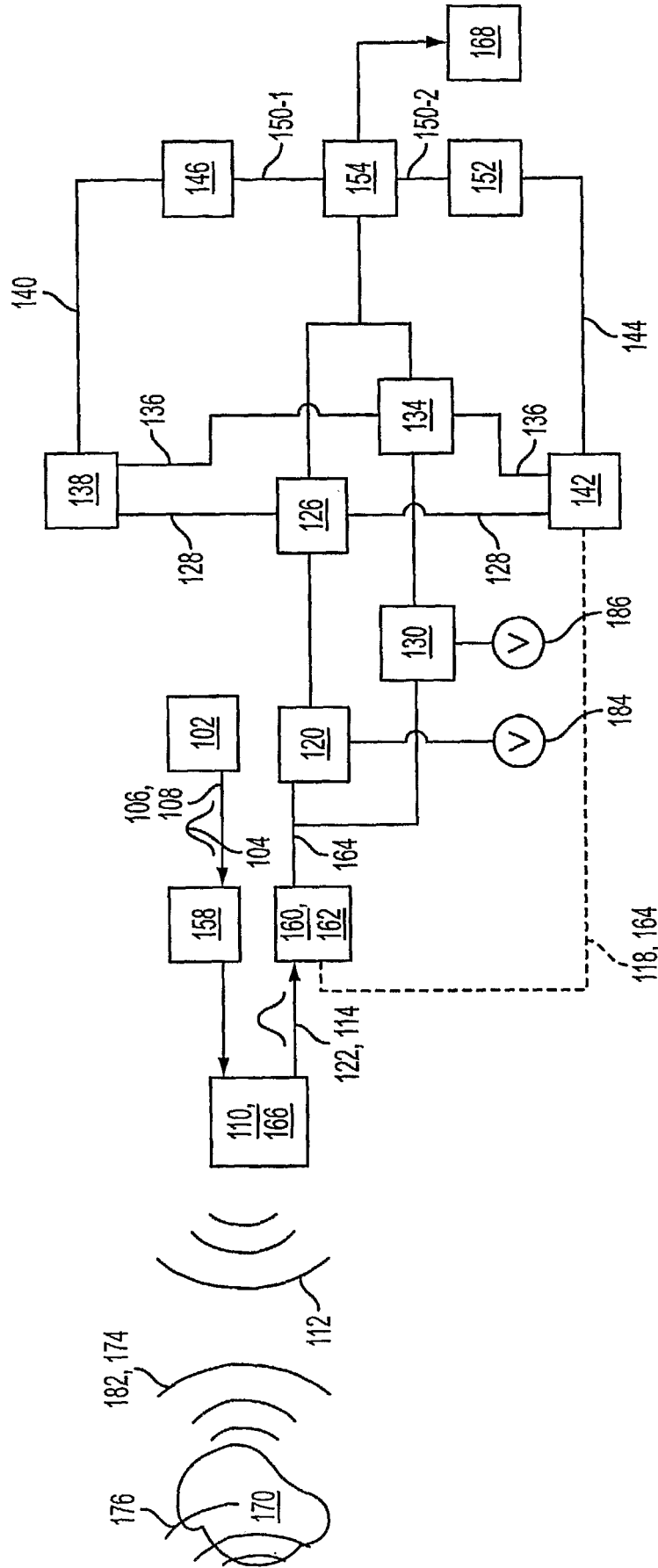

FIG. 1

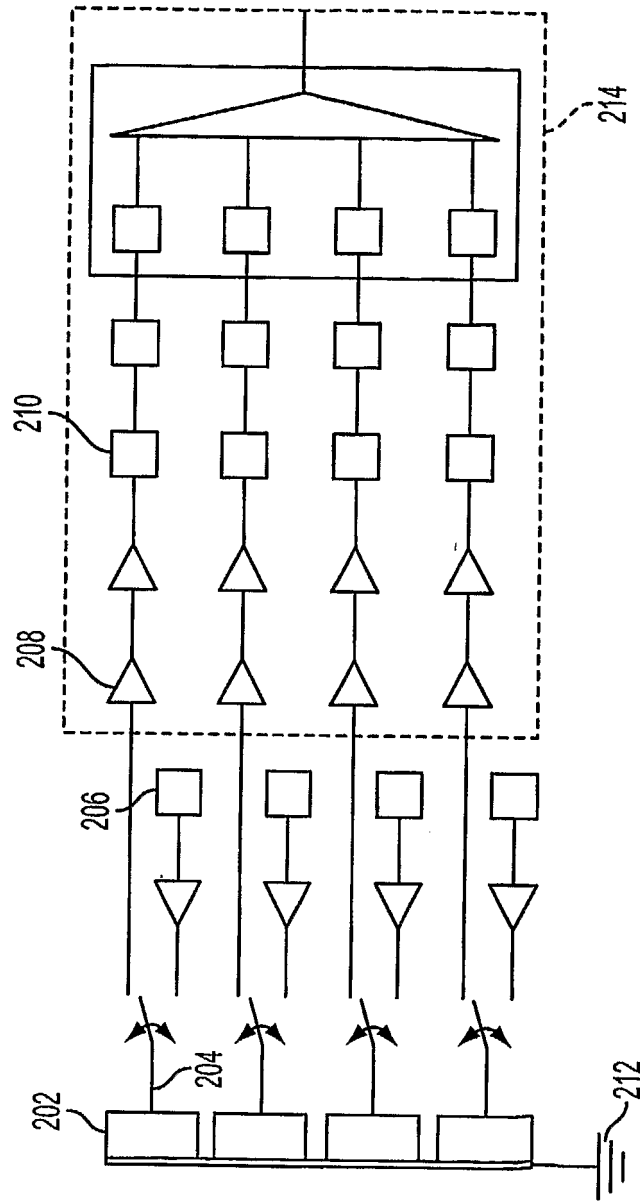

FIG. 2

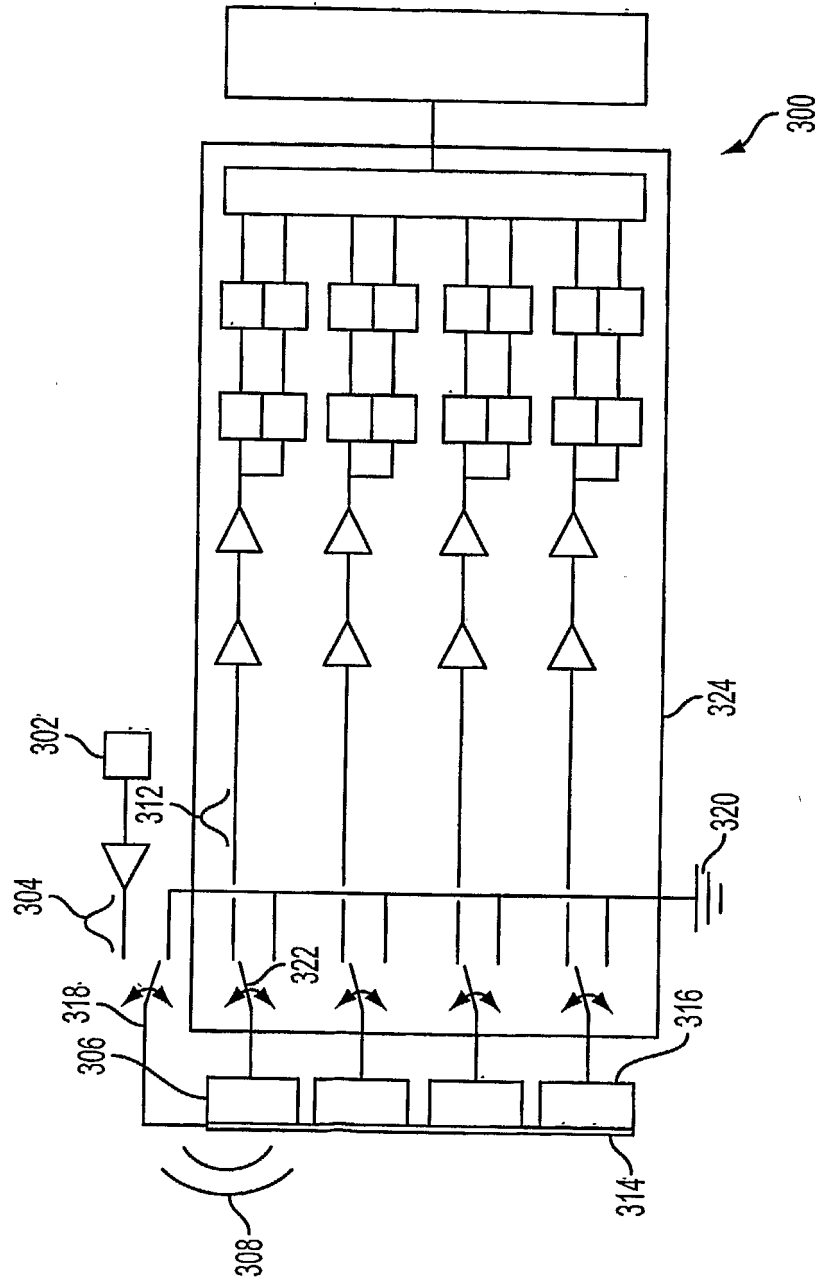

FIG. 3

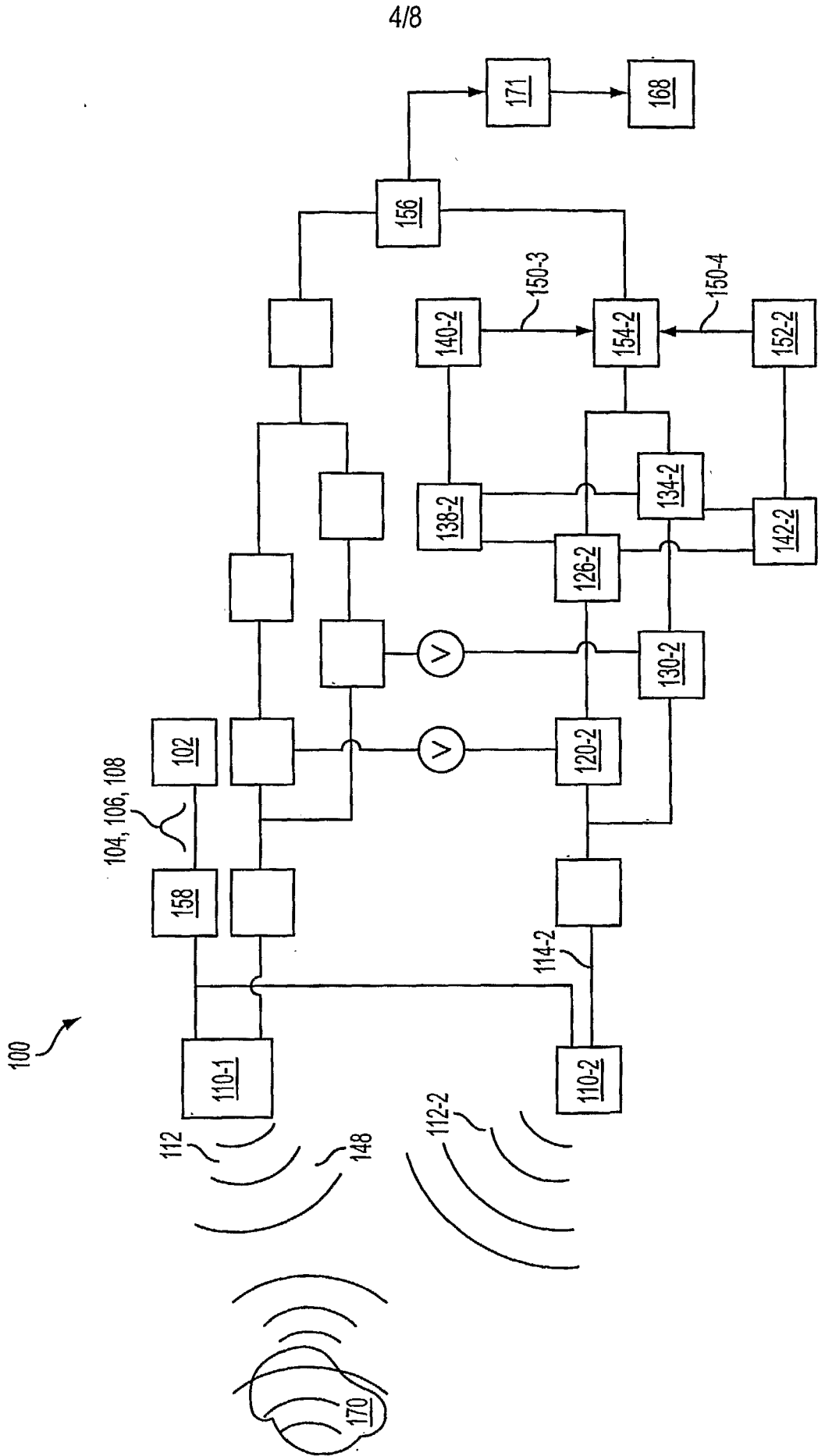
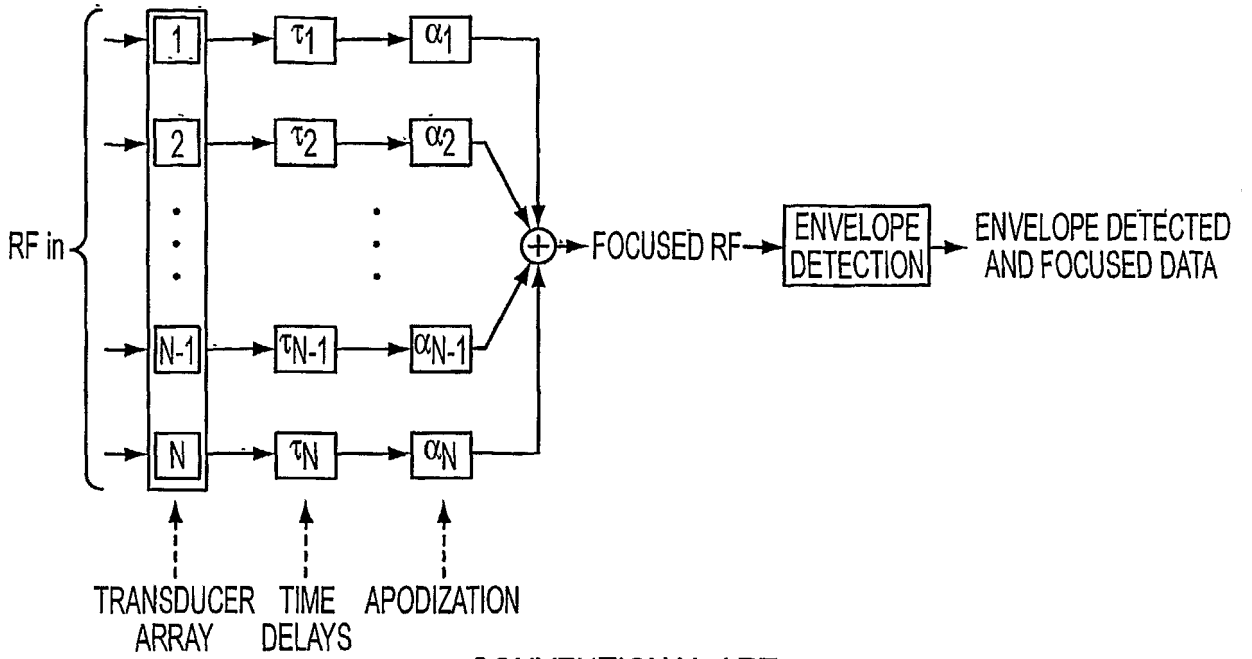
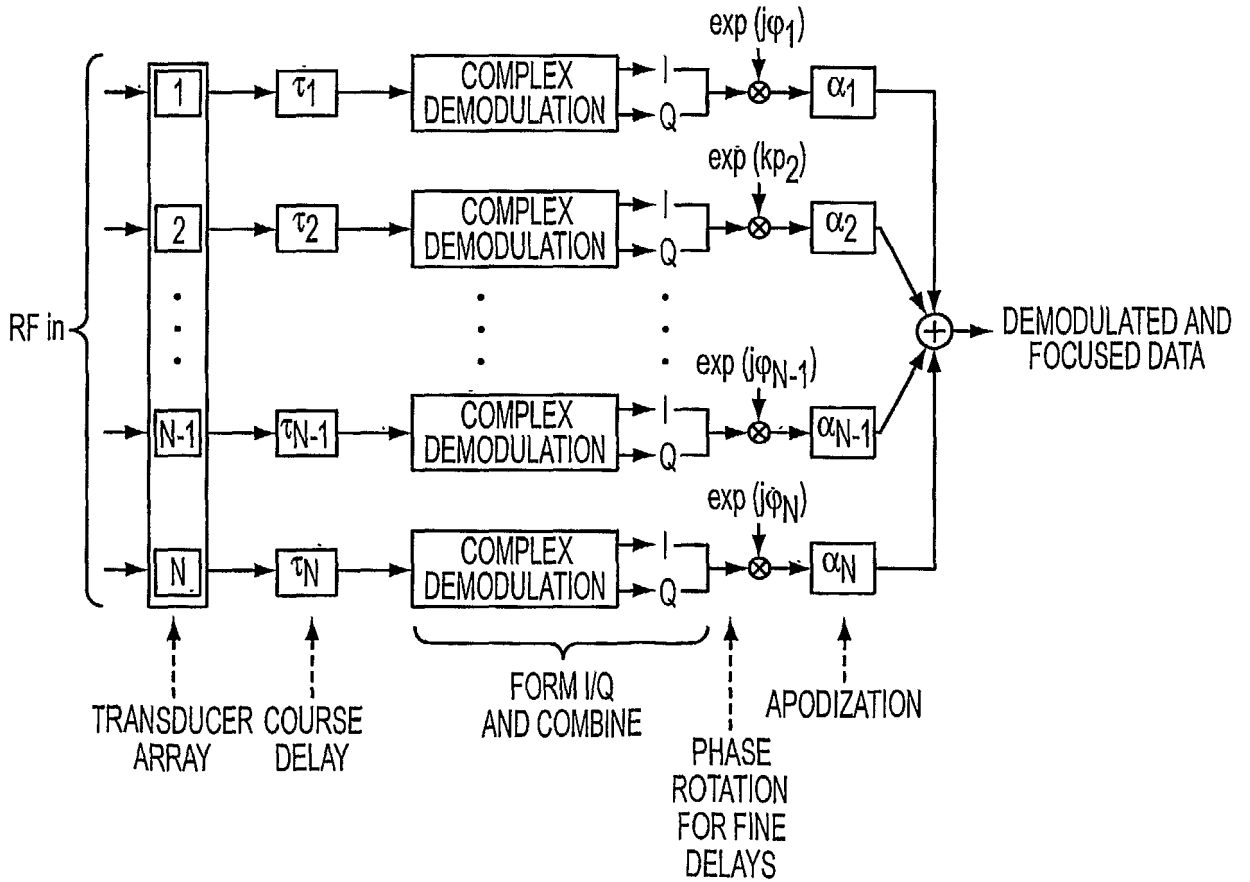

FIG. 4

5/8



CONVENTIONAL ART
FIG. 5A



CONVENTIONAL ART
FIG. 5B

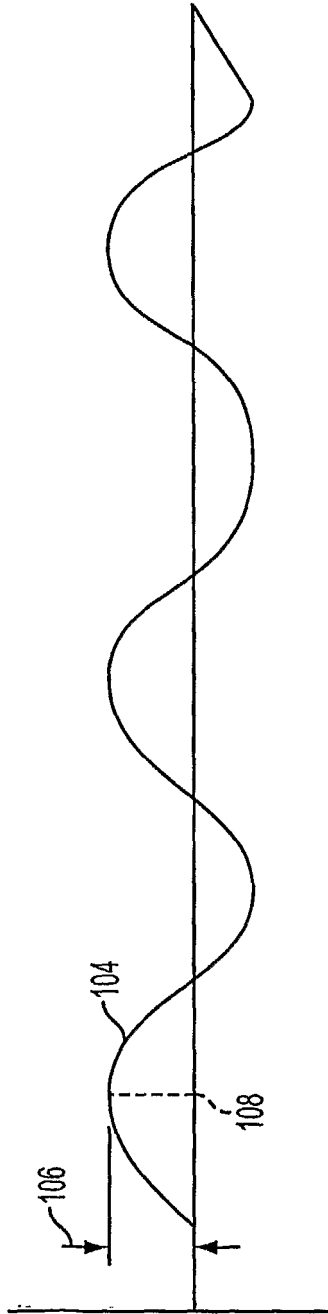

FIG. 6A

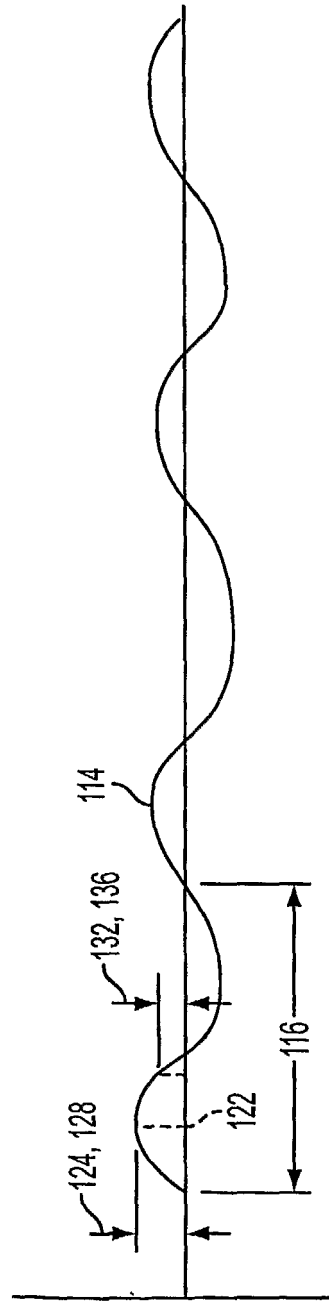

FIG. 6B

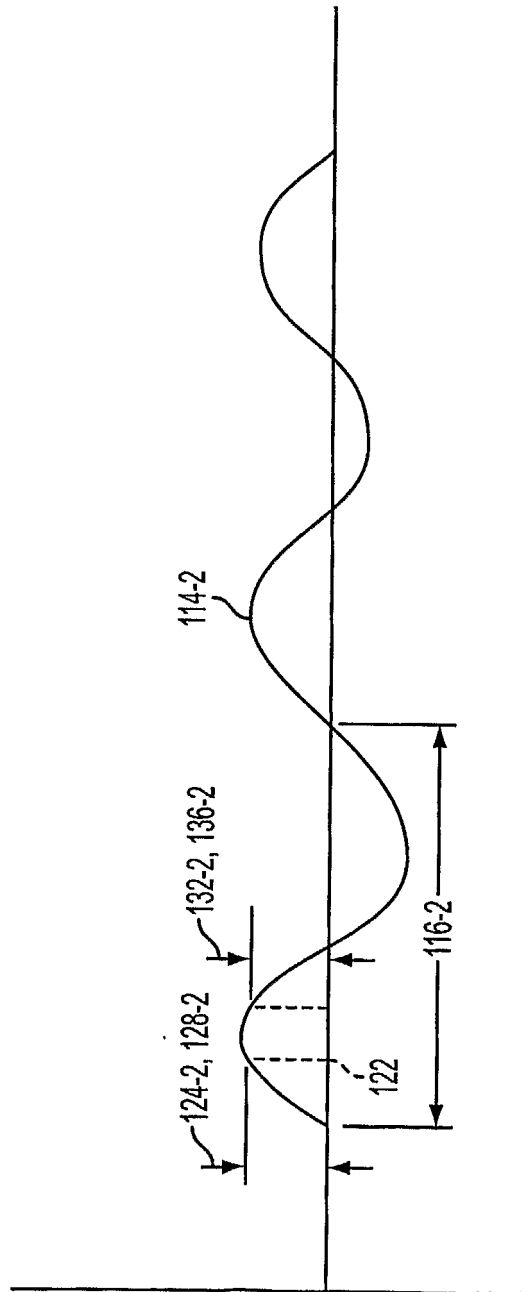

FIG. 6C

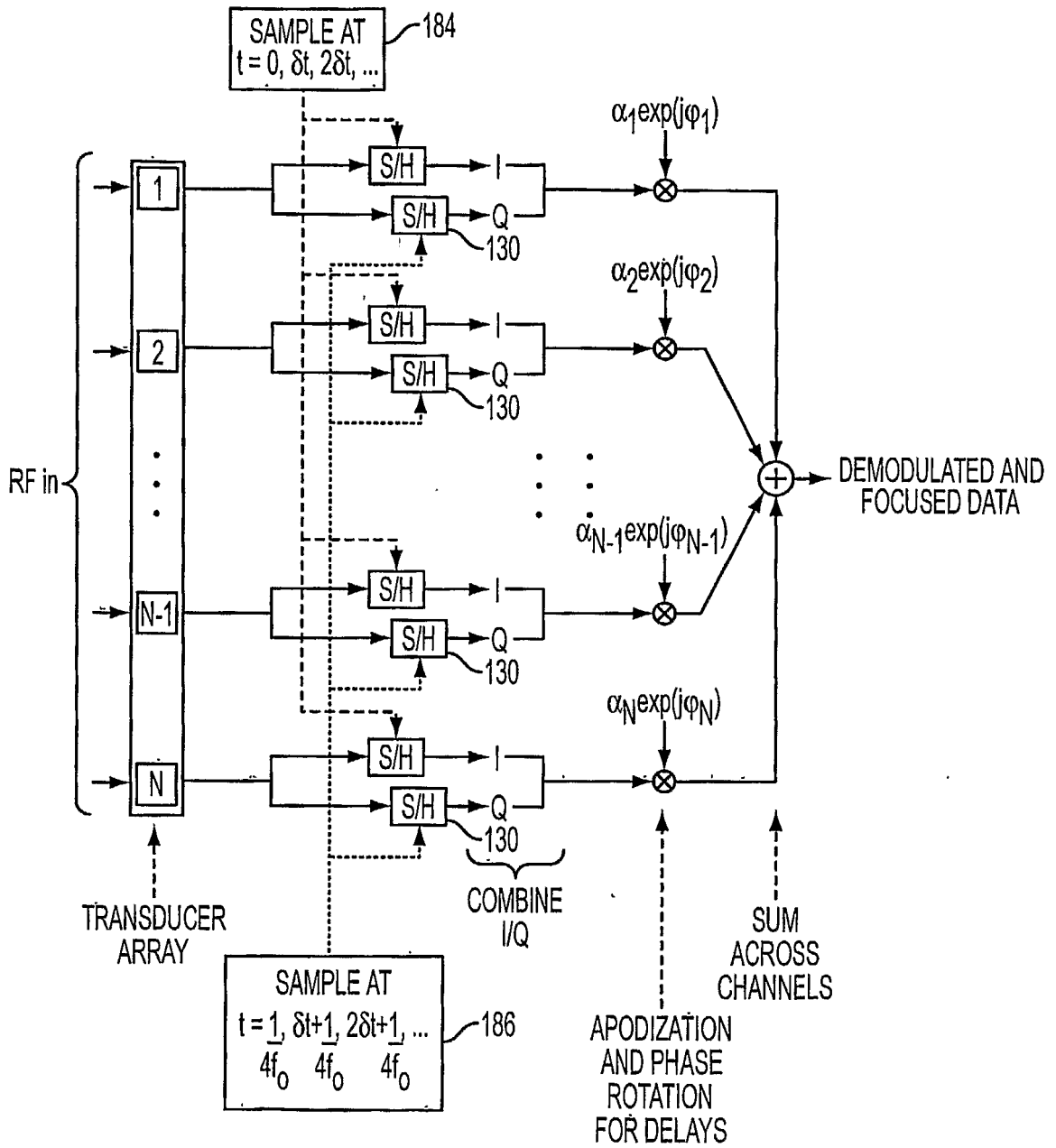

FIG. 7

专利名称(译)	超声成像光束成形装置和方法		
公开(公告)号	EP1622514A2	公开(公告)日	2006-02-08
申请号	EP2004702168	申请日	2004-01-14
[标]申请(专利权)人(译)	弗吉尼亚大学专利基金会		
申请(专利权)人(译)	VIRGINIA专利大学基金会		
当前申请(专利权)人(译)	VIRGINIA专利大学基金会		
[标]发明人	BLALOCK TRAVIS N WALKER WILLIAM F HOSSACK JOHN A		
发明人	BLALOCK, TRAVIS, N. WALKER, WILLIAM, F. HOSSACK, JOHN, A.		
IPC分类号	A61B8/00 G01S15/89 A61B A61B8/14 G10K11/34		
CPC分类号	A61B8/4494 A61B8/00 A61B8/145 A61B8/4483 A61B8/4488 A61B8/461 A61B8/5207 G01S7/52028 G01S7/52034 G01S7/5208 G01S7/52085 G01S15/8915 G01S15/8959 G01S15/8995 G10K11/346		
优先权	60/440262 2003-01-15 US 60/440020 2003-01-14 US 60/439990 2003-01-14 US		
其他公开文献	EP1622514A4 EP1622514B1		
外部链接	Espacenet		

摘要(译)

在一些说明性实施例中，来自超声成像光束成形器装置 (100) 中的换能器 (110) 的输入信号被应用于同相采样 - 保持 (120) 和正交采样 - 保持 (130)。)。正交采样和保持 (130) 可以在同相采样和保持 (120) 之后的四分之一周期计时。采样和保持的输出应用于同相和正交模数转换器 (126)。幅度计算器 (138) 接收同相和正交数字值，并输出幅度。相位计算器 (142) 接收同相和正交数字值，并输出相位。变迹器 (146) 应用输出信号的幅度与幅度之间的差值，并且将第一照度 (150-1) 应用于与差值成大比例的图像点 (154)，并且相位旋转器 (152) 适用第二次照射 (150-2) 到图像点 (154)，与相位成大比例。