

(19)



(11)

**EP 2 424 440 B1**

(12)

**EUROPEAN PATENT SPECIFICATION**

(45) Date of publication and mention of the grant of the patent:  
**08.01.2014 Bulletin 2014/02**

(51) Int Cl.:  
**G01S 15/89** <sup>(2006.01)</sup>      **G01S 7/52** <sup>(2006.01)</sup>  
**A61B 8/08** <sup>(2006.01)</sup>      **A61B 17/34** <sup>(2006.01)</sup>

(21) Application number: **10725868.3**

(86) International application number:  
**PCT/IB2010/051782**

(22) Date of filing: **23.04.2010**

(87) International publication number:  
**WO 2010/125505 (04.11.2010 Gazette 2010/44)**

(54) **BIOPSY GUIDE SYSTEM WITH AN ULTRASOUND TRANSDUCER AND METHOD OF USING SAME**

BIOPSIEFÜHRUNGSSYSTEM MIT EINEM SCHALLKOPF UND ANWENDUNGSVERFAHREN DAFÜR

SYSTEME DE GUIDAGE POUR BIOPSIE AVEC TRANSDUCTEUR ULTRASONORE ET PROCEDE D'UTILISATION ASSOCIE

(84) Designated Contracting States:  
**AT BE BG CH CY CZ DE DK EE ES FI FR GB GR HR HU IE IS IT LI LT LU LV MC MK MT NL NO PL PT RO SE SI SK SM TR**

(72) Inventor: **ROBINSON, Andrew L.**  
**NL-5656 AE Eindhoven (NL)**

(30) Priority: **28.04.2009 US 173285 P**

(74) Representative: **van Velzen, Maaïke Mathilde Philips**  
**Intellectual Property & Standards**  
**P.O. Box 220**  
**5600 AE Eindhoven (NL)**

(43) Date of publication of application:  
**07.03.2012 Bulletin 2012/10**

(73) Proprietor: **Koninklijke Philips N.V.**  
**5656 AE Eindhoven (NL)**

(56) References cited:  
**EP-A2- 1 323 380**      **EP-A2- 1 804 079**  
**WO-A1-2006/109219**      **WO-A2-2007/027511**  
**US-A- 5 623 931**      **US-A1- 2002 156 376**  
**US-A1- 2002 173 719**

**EP 2 424 440 B1**

Note: Within nine months of the publication of the mention of the grant of the European patent in the European Patent Bulletin, any person may give notice to the European Patent Office of opposition to that patent, in accordance with the Implementing Regulations. Notice of opposition shall not be deemed to have been filed until the opposition fee has been paid. (Art. 99(1) European Patent Convention).

## Description

### FIELD OF THE INVENTION

**[0001]** The invention relates to a biopsy guide system for guiding a biopsy needle along a biopsy path while monitoring with an ultrasound transducer. Furthermore, the invention relates to a method of controlling guidance of a biopsy needle using such biopsy guide.

### BACKGROUND OF THE INVENTION

**[0002]** A biopsy is a medical test involving the removal of cells or tissues from a region of interest such as a lesion for medical examination purposes. The removed cells or tissues may be examined in order to detect the presence or extent of a disease.

**[0003]** For removing the cells or tissues, a biopsy needle has to be introduced into a patient's body and has to be guided to the region of interest. In order to enable monitoring of the introduction and guidance of the biopsy needle, ultrasound transducers are frequently used to observe the region of interest during the insertion of the biopsy needle.

**[0004]** As described for example in WO2006/060657-A2, a biopsy needle guide adapted for guiding a biopsy needle along a biopsy path may be coupled to a conventional ultrasound transducer device.

**[0005]** As schematically shown in Figs. 1-3, a conventional ultrasound transducer 103 comprises a one-dimensional (1D) transducer face 104 from which ultrasonic signals may be emitted. Thereby, an image plane underneath the transducer face may be observed by detecting echoes of reflected ultrasonic signals coming from inhomogeneities of the observed region. By correctly positioning the ultrasound transducer 103, a region of interest comprising for example a lesion 108 may be observed. A biopsy needle guide 105 may be attached close to the transducer face 104 and may be adapted to guide a biopsy needle along a biopsy path 107 into the lesion 108.

**[0006]** Conventional one-dimensional ultrasound transducers comprise an array of elements 109 arranged in a line. A division of elements 109 in a line allows each element 109 to transmit and receive separate ultrasound signals, which may be combined to generate an image. The transducers array face 104 is usually a rectangle, where the long direction is generally referred to as the "azimuth" direction and the orthogonal direction is generally referred to as the "elevation" direction. Because the elements 109 are arranged in a single line, the ultrasound beam can be steered and focused in a region that is orthogonal to the face 104 of the transducer 103 but which is most simply described as a plane. This plane extends in the azimuth direction and in the "range" direction, where the range direction is orthogonal to the transducer array face and therefore orthogonal to both the azimuth and elevation directions. Although the transducer face is usually a rectangle, the field of view may be a

triangle, rectangle or trapezoid that is orthogonal to the array face 104 and extends in the azimuth and range directions; this is generally referred to as the azimuthal plane.

**[0007]** In the example shown in Fig.2, the field of view 110 is trapezoidal. The length of the transducer array in the elevation direction may determine, in conjunction with a mechanical lens, the focal characteristics in the elevation direction generally referred to as "slice thickness". Ideally, slice thickness would be zero so that the image represents a cross-section of the patient orthogonal to the face of the array, but in practice, slice thickness cannot be zero. The image presented on the ultrasound system screen, while portrayed in a single plane, is in fact a projection of the ultrasound information contained in the non-zero slice in the azimuth plane. The slice thickness is not constant throughout the depth of the image. At the face of the transducer, it is equal to the elevation direction; as depth increases the slice thickness decreases as the elevation direction and lens curvature are combined to focus the ultrasound energy; past the focal depth, i.e. the depth at which the slice thickness is smallest, the ultrasound beam diverges and the slice thickness increases. To further complicate matters, the ultrasound beam does not have perfectly sharp boundaries. In the below description, simple planar structures will be used to illustrate ultrasound imaging fields of view that are in fact a fairly complex sampling of a three-dimensional space.

**[0008]** While in Fig. 1, the ultrasound transducer 103 is shown with a planar one-dimensional array face 104, the one-dimensional array can also be formed on a curved surface, in which case it is generally referred to as a "curved linear array" (CLA). This is illustrated in Fig.3. Such a CLA, rather than being a rectangle, is a section of a cylinder. The resulting field of view 110' is a section of a circle with the inner boundary being the array face 104'. Although, in the following description, most of the examples presented are for a flat array, the ideas of the invention may be equally applicable to a curved array.

**[0009]** As in conventional biopsy guide systems the ultrasound transducer acquires an image of the observed tissue only along an azimuthal plane, the biopsy needle guide attached to the ultrasound transducer is usually designed to support needle entry on the azimuthal plane. A different needle guide location could be used, but since the biopsy needles path would not fall within the single available imaging plane, no guidance imaging may be available as the needle will not be visible until it passes through the imaging plane.

**[0010]** Accordingly, in conventional biopsy procedures, the biopsy guide system including the ultrasound transducer will be moved along the surface above the region of interest until the actual region of interest (including e.g. a lesion) may be seen on the acquired ultrasound image, i.e. until the imaging plane crosses the region of interest. Then, the biopsy needle may be introduced into the tissue along the azimuthal plane. As the

needle moves along the imaging plane, the current location of the needle may be monitored in the ultrasound image. A biopsy may be taken as soon as the region of interest has been reached.

**[0011]** Document US 2002/0173719 A1 discloses a method, system, computer program product, and user interface for real-time ultrasonic visualization enhancement of a biopsy needle are disclosed in which a wide range of needle positions with respect to the ultrasound probe axis and with respect to the imaged plane are accommodated. Ordinary frames are compounded with special purpose frames, the special purpose frames having transmit and receive parameters adapted to highlight reception of echoes from the biopsy needle. Preferably, an elevation beam width associated with the special purpose ultrasound frames is wider than an elevation beam width associated with the ordinary ultrasound frames. Preferably, the beams of the special purpose ultrasound frames are steered such that they are incident upon the biopsy needle at an increased angle as compared to the angle of incidence for ordinary ultrasound frames. A method for automatically and adaptively determining the depth and orientation of a biopsy needle is also described, whereby beam steering parameters, focus parameters, etc. may be automatically and adaptively computed. The user may optionally provide selected beam steering parameters to the ultrasound imaging system using a simple, intuitive user interface.

**[0012]** Document EP 1 804 079 A2 discloses an ultrasonic diagnosis apparatus according to the present invention includes an ultrasonic endoscope having ultrasonic transducers for scanning ultrasonic wave in a living body three-dimensionally, an ultrasonic image creating portion of an ultrasonic observing apparatus for creating ultrasonic volume data based on an ultrasonic signal captured by the ultrasonic endoscope, a two-dimensional image select knob, keyboard, trackball, computing/control portion and display control portion for selecting a tomographic plane from the ultrasonic volume data by designating the angle of rotation about the straight line through two points designated on the ultrasonic volume data as the axis of rotation, and a monitor for displaying the tomographic plane selected during a scanning operation as a two-dimensional ultrasonic image.

**[0013]** Document US 2002/0156376 A1 discloses an instrument guide for mounting the instrument to an imaging probe, controlling its position, monitoring its position, and/or predictively displaying its position on a user display of the medical imaging system. A plurality of substantially rigid segments are hingeably connected to the probe, to an instrument handle, and to each other such that movement of the biopsy needle is restricted to within the imaged plane. However, substantial freedom of movement within the imaged plane is provided such that the instrument may be inserted into the patient over a wide range of angles. In one preferred embodiment, angle detectors are provided at each segment intersection and provided to the medical imaging system for comput-

ing and displaying the position and orientation of the instrument on the user display. The instrument guide/position monitor is preferably made with low-cost components such that it is disposable after a single use. In another preferred embodiment, a predictive user display is provided in which the throw of a spring-loaded instrument is shown on the user display, the throw corresponding to the space that the instrument will occupy after a spring trigger is activated.

## SUMMARY OF THE INVENTION

**[0014]** The inventor has considered that a desirable point of entry for the biopsy needle may be constrained by acoustic access or other features on the patient's body. Therefore, it may be desirable to be able to image needle entry from another position. For example, it may be desirable to image the entry of a needle introduced from a position different to the azimuthal position.

**[0015]** It is an object of the invention to provide a biopsy guide system which allows for an improved flexibility in selecting an entry location for a biopsy needle while enabling monitoring an insertion of the biopsy needle. It is another object of the invention to provide a method of controlling the guidance of a biopsy needle using such biopsy guide system.

**[0016]** The invention is defined by the independent claims. Advantageous embodiments are defined in the dependent claims.

**[0017]** According to a first aspect of the present invention, a multi-position biopsy guide system is proposed. It comprises a 2D matrix ultrasound transducer and at least two biopsy needles along biopsy paths extending in different planes; the multiposition biopsy guide system being adapted to controllably guide the biopsy needle along biopsy paths at variable locations with respect to the 2D matrix ultrasound transducer, and to acquire ultrasound images in respective image planes aligned with the biopsy paths of each of the biopsy needle guides.

**[0018]** According to a second aspect of the present invention, a method of controlling guidance of a biopsy needle along a biopsy path using the multi-position biopsy guide system according to the first aspect of the invention is proposed. The method comprises (a) determining a location of at least two biopsy needle guides with respect to the 2D matrix ultrasound transducer, and (b) acquiring ultrasound images in image planes aligned with the biopsy path corresponding to the determined location of the biopsy needle guides.

**[0019]** The present invention may be seen as based on the following idea:

**[0020]** In conventional biopsy guide systems using one-dimensional ultrasound transducer arrays, a biopsy needle has to be guided such that it enters into the tissue in alignment with the imaging plane of the ultrasound transducer. Accordingly, only biopsy needles introduced along a biopsy path correctly aligned may be monitored.

**[0021]** The multi-position biopsy guide system accord-

ing to the first aspect of the present invention comprises a two-dimensional matrix ultrasound transducer. Such transducer may comprise an array of ultrasound transducer elements arranged in columns and rows. The transducer array face may still be rectangular as in the case of a one-dimensional ultrasound transducer but the array of transducer elements is separated into a two-dimensional matrix. This additional complexity may allow for ultrasound beams to be steered and focused through a three-dimensional space rather than in only a nominal plane.

**[0022]** Thus, the field of view, rather than being a single trapezoid, may be a volume that is generally a truncated pyramid or, in the case of a sector transducer, an entire pyramid with its apex at the transducer face. Information from within the field of view may be acquired and displayed in many ways. The user may choose to view one or more planes in an azimuth or elevation direction. It is also possible to illustrate so-called X-plane imaging, where an azimuth and an elevation plane are displayed simultaneously. Furthermore, diagonal planes may be imaged. Finally, ultrasound information can be rendered into a 3D or volume representation, the best known example of which is the so-called "baby face". This list of potential display planes may not be complete but illustrates the capability of matrix transducers to display information acquired from within the volume field of view.

**[0023]** An idea of the present invention is to exploit this capability of flexible image acquisition and display from within the volume field of view. Using a 2D matrix ultrasound transducer enables alignment of an image plane with an arbitrary biopsy path along which a biopsy needle is guided into a patient's tissue. Accordingly, a biopsy needle guide may be arranged at any desired location for example along a circumference of the matrix ultrasound transducer and the ultrasound transducer may be controlled such as to acquire an ultrasound image in an imaging plane coinciding with a biopsy path along which a biopsy needle is guided by the biopsy needle guide.

**[0024]** Accordingly, the proposed biopsy guide system that provides for multiple needle entry locations would allow a user to choose the most appropriate location for a given situation. Multiple needle entry locations may take advantage of imaging capabilities of a matrix transducer, in particular the ability to image multiple planes simultaneously or alternatively (e.g. X-planes), planes that do not align to the transducers primary axis (azimuth or elevation), or volumes.

**[0025]** In accordance with specific embodiments of the present invention described further below in more detail, it is also possible to adapt the location and/or orientation of an imaging plane to a varying location of a biopsy needle for example in a case, where a flexible biopsy needle is deflected from its originally intended biopsy path due to inhomogeneities in the patient's tissue or due to other mechanical obstacles. Furthermore, it is also possible to monitor the insertion of two or more biopsy needles introduced simultaneously or alternately along different bi-

opsy paths.

**[0026]** Possible features and advantages of embodiments of the present invention will be described in more detail in the following.

5 **[0027]** The two-dimensional matrix ultrasound transducer used in the proposed multiposition biopsy guide system may comprise a multiplicity of ultrasound transceiver elements adapted for emitting ultrasound waves and receiving echoes thereof. The elements may be arranged in a matrix fashion such that each row and each column comprises a plurality of adjacent transducer elements. The size of each transducer element as well as the overall size and geometry of the matrix ultrasound transducer may be adapted to a specific application. For example, the matrix ultrasound transducer may comprise a rectangular array of transducer elements. The transducer elements may be arranged and controlled such as to enable steering and focusing of an emitted ultrasound wave in any arbitrary direction or plane within a three-dimensional region of observation.

10 **[0028]** The biopsy needle guide of the proposed multiposition biopsy guide system may be adapted such that the biopsy needle may be introduced into a patient's tissue along a biopsy path wherein the location of the biopsy path may be controllably varied. For example, the biopsy needle guide may be either located in an azimuth position with respect to a rectangular 2D matrix ultrasound transducer or, alternatively, in an elevation position. It may also be positioned at any other location with respect to the ultrasound transducer. Alternatively, a multiplicity of biopsy needle guides may be arranged at different locations with respect to the ultrasound transducer such that each of the biopsy needle guides may introduce a biopsy needle along a different biopsy path.

15 **[0029]** According to an embodiment of the present invention, the two-dimensional matrix ultrasound transducer is adapted to acquire ultrasound images in an image plane which image plane is controllably variable. In other words, the ultrasound transducer may be controlled, e.g. by a control device, in a manner that addresses the transducer elements of the matrix transducer in such a way that ultrasound signals are emitted in a selectable imaging plane. From the detected echoes, an image of the region of observation in this imaging plane can be acquired.

20 **[0030]** According to another embodiment of the present invention, the multi-position biopsy guide system is adapted to mount the biopsy needle guide in variable locations with respect to the 2D matrix ultrasound transducer. In other words, one or more biopsy needle guides may be mounted at one of a plurality of possible mounting locations for example along a circumference around the matrix ultrasound transducer. Then, for example depending on space requirements occurring in a specific medical application, a biopsy needle may be guided along a preferred biopsy path using a biopsy needle guide located in one of the provided possible locations.

25 **[0031]** According to a further embodiment of the

present invention, the multi-position biopsy guide system is adapted to determine the location of the biopsy needle guide with respect to the 2D matrix ultrasound transducer. For example, the location of the biopsy needle guide may be input manually by a user after previous mounting of the biopsy needle guide at a specific location. Alternatively, the proposed multi-position biopsy guide system may automatically determine the location of the biopsy needle guide. For example, switches may be provided at possible mounting locations for the biopsy needle guide such that, when a biopsy needle guide is mounted at a specific location, a respective switch is operated and indicates the location.

**[0032]** According to a further embodiment of the present invention, the multi-position biopsy guide system is adapted to acquire an ultrasound image in an image plane aligned with the biopsy path corresponding to the determined location of a biopsy needle guide. In other words, the proposed multi-position biopsy guide system may have a control device which is, on the one hand, able to determine the location of the biopsy needle guide and which, on the other hand, is able to control the 2D matrix ultrasound transducer such that an ultrasound image is acquired in an imaging plane which is aligned with the biopsy path of a biopsy needle guided by the biopsy needle guide in the determined location. Accordingly, ultrasound imaging may be automatically aligned with the biopsy path thereby allowing easy and fast monitoring of the process of introducing the biopsy needle.

**[0033]** According to a further embodiment of the present invention, the proposed multiposition biopsy guide system comprises at least two biopsy needle guides. In such embodiment, the two biopsy needle guides may be arranged such that biopsy needles may be introduced into a patient's tissue along biopsy paths extending in different planes. For example, one biopsy needle guide may be arranged in an azimuth direction and another biopsy needle guide may be arranged in an elevation direction. Alternatively, further biopsy needle guides may be provided for example in a diagonal direction. Each of the biopsy needle guides may be used alternatively depending on specific requirements of a medical application. For example, in one medical application, it may be advantageous to introduce a biopsy needle along an azimuthal direction whereas in another medical application the elevation direction may be preferred.

**[0034]** It may also be advantageous to use the at least two biopsy needle guides to introduce two or more biopsy needles simultaneously. For example, it may be desired to introduce a first biopsy needle to a region of interest for application of a medical, pharmaceutical or contrast agent. A second biopsy needle may be used to actually acquire a biopsy sample from the region of interest. Alternatively, two biopsy needles may be guided to a region of interest to apply therapy treatment in order to destroy deteriorated tissue.

**[0035]** According to a further embodiment of the present invention, the multi-position biopsy guide system

is adapted to acquire ultrasound images in respective image planes aligned with the biopsy paths of each of the biopsy needle guides. In other words, as the 2D matrix ultrasound transducer may be able to acquire ultrasound images in any arbitrary image plane, it may be advantageous to acquire ultrasound image in imaging planes coinciding with each of the possible biopsy paths such that introduction of one or preferably several biopsy needles along the several possible biopsy paths may be observed quasi-simultaneously or alternately.

**[0036]** According to a further embodiment of the present invention, the biopsy needle guide is adapted for guiding the biopsy needle along a biopsy path at controllably variable angles. In other words, a biopsy needle guide may include provisions to allow for different tilting of a guided biopsy needle such that the biopsy needle may be introduced into a patient's tissue under a selectable angle. Accordingly, the introduction angle of the biopsy needle can be chosen such that a specific location of a region of interest may be reached with the biopsy needle. This may be particularly advantageous in case a biopsy needle guide may be mounted at the proposed multi-position biopsy guide system at different selected locations such as at azimuth locations or at elevation locations. Depending on the selected location, a different introduction angle may be required for the biopsy needle in order to reach a region of interest.

**[0037]** According to a further embodiment of the present invention, the biopsy needle guide is adapted for guiding different types of biopsy needles. The type of biopsy needle may be adapted for a specific medical application. For example, the biopsy needles may differ in length, shape or diameter.

**[0038]** According to a further embodiment of the present invention, the 2D matrix ultrasound transducer is adapted to acquire 3D ultrasound images. The ability of a 2D matrix ultrasound transducer to acquire ultrasound images from a volume may allow for the ability of deriving 3D ultrasound images. Thereby, it is possible to provide a 3D or volume representation of a region of interest. Such 3D representation may even be time-dependent (sometimes referred to as "live 3D " or "4D") by concatenating a plurality of 3D representations acquired in a time sequence. Biopsy needles may be guided within an acquired 3D image. Biopsy guidance in live 3D may provide better awareness of nearby structures and may thereby help to avoid mistakes during the procedure.

**[0039]** A biopsy arrangement comprising a multi-position biopsy guide system as described above and further comprising a display device for displaying ultrasound images acquired by the 2D matrix ultrasound transducer may be used to assist a physician in finding a region of interest and/or monitoring the guidance of a biopsy needle towards the region of interest. For example, an ultrasound image may be displayed on the display device wherein the location and orientation of the image plane in which the ultrasound image is acquired may be manually aligned by the surgeon or automatically aligned by

the biopsy arrangement itself such that a process of introducing the biopsy needle may be effectively monitored. Alternatively, two or more ultrasound images may be acquired and displayed. For example, a first ultrasound image may be acquired in a direction coinciding with the biopsy path while a second ultrasound image may be acquired in a direction orthogonal thereto. From the second ultrasound image a surgeon may learn where the biopsy needle crosses the region of interest in a plane perpendicular to the biopsy path. Alternatively, two or more biopsy needles may be monitored. The two or more ultrasound images may be displayed simultaneously, for example side-by-side, or alternately. Accordingly, a surgeon may acquire image information and monitor a biopsy process in different imaging planes without the necessity to move the ultrasound transducer.

**[0040]** According to an embodiment of the method according to the above second aspect of the invention, at least two biopsy needles are guided using separate biopsy needle guides and each biopsy needle is visualized in respective corresponding imaging planes using the 2D matrix ultrasound transducer (3). Both needles may be visualized simultaneously or alternately.

**[0041]** It has to be noted that aspects and embodiments of the present invention have been described with reference to different subject-matters. In particular, some embodiments have been described with reference to apparatus-type claims whereas other embodiments or features have been described with reference to method-type claims. However, a person skilled in the art will gather from the above and the following description that, unless other notified, in addition to any combination of features belonging to one type of subject-matter also any combination between features relating to different subject-matters, in particular between features of the apparatus-type claims and features of the method-type claims, is considered to be disclosed with this application.

#### BRIEF DESCRIPTION OF THE DRAWINGS

**[0042]** Features and advantages of the present invention will be further described with respect to specific embodiments as shown in the accompanying figures but to which the invention shall not be limited.

Fig.1 shows a perspective view of a conventional biopsy guide.

Fig.2 shows a schematical side view of a conventional biopsy guide system with a one-dimensional ultrasound transducer.

Fig.3 schematically shows a one-dimensional ultrasound transducer surface with a curved linear array (CLA).

Fig.4 schematically shows a two-dimensional matrix ultrasound transducer usable in a multi-position biopsy guide system according to an embodiment of the present invention.

Figs. 5a, 5b illustrate azimuthal and elevational ori-

ented imaging planes of the two-dimensional matrix ultrasound transducer shown in Fig. 4.

Fig.6 schematically shows a top view on a multi-position biopsy guide system according to an embodiment of the present invention.

Fig.7 schematically shows imaging planes corresponding to locations of biopsy needle guides of the embodiment of the present invention shown in Fig.6.

Fig.8 shows a schematic representation of a 3D view of a lesion and a diagonal biopsy needle path for a multi-position biopsy guide system according to an embodiment of the present invention.

Figs. 9a-9c show 2D cross-sections through the 3D volume of Fig.8 in an azimuthal, elevational and diagonal direction.

Figs. 10a-10c show the cross-sections of Figs. 9a-9c with the addition of a biopsy path appropriate to each plane.

**[0043]** The drawings are only schematical and not to scale. Similar elements are indicated with similar reference signs.

#### DETAILED DESCRIPTION OF INVENTION

**[0044]** The conventional biopsy guide system 100 shown in Fig.1 comprises a 1D ultrasound transducer 103. A biopsy guide bracket 106 is arranged around the transducer face 104. In an azimuthal position with respect to the longitudinal transducer face 104, a biopsy needle guide 105 is attached to the biopsy guide bracket 106. As indicated in Fig.2, the ultrasound transducer 103 with the one-dimensional transducer face 104 is adapted to acquire an image from within a trapezoidal region included in an image plane 110 coinciding with and orthogonal to the transducer face 104.

**[0045]** While with the conventional biopsy guide system shown in Fig.1 and 2 the image plane 110 has to be moved together with the biopsy guide system until it coincides with a region of interest 108 such that a biopsy needle may be guided along a biopsy path 107 using the biopsy needle guide 105, Fig.4 illustrates an advantage which may be obtained when using a two-dimensional matrix ultrasound transducer for the biopsy guide system in accordance with an embodiment of the present invention. Using such two-dimensional matrix ultrasound transducer 3 having a matrix of transducer elements 9 arranged in rows and columns it is possible to provide a field of view 10 in a shape of a truncated pyramid. Accordingly, the field of view is not restricted to a single plane but covers a three-dimensional space.

**[0046]** Information from within the field of view 10 can be displayed in many ways. As illustrated in Fig.5a, a user may choose to view one or more planes 10' in the azimuth direction. Alternatively, as shown in Fig.5b, image planes 10" in an elevation direction may be provided. Also any other orientation of image planes may be provided using a two-dimensional matrix ultrasound trans-

ducer.

[0047] As schematically indicated in the top view shown in Fig.6, one or more biopsy needle guides 5', 5", 5''' may be provided at different locations around the two-dimensional matrix ultrasound transducer 3. With reference to Fig.7, a first biopsy needle guide 5' in an azimuthal position may be aligned with an azimuth image plane 10'. A second biopsy needle guide 5'' arranged in a corner of the rectangular transducer face of the matrix transducer 3 may be aligned with a diagonal image plane 10''. A third biopsy needle guide 5''' arranged at an elevation position may be aligned with an elevation imaging plane 10'''.

[0048] Fig.8 is a schematic representation of a three-dimensional field of view of a matrix transducer 3. Within the field of view is a lesion 8 to be biopsied. Around an edge of the transducer's 3 lens three small rectangle 5', 5", 5''' are illustrated to indicate potential locations for a biopsy needle guide with biopsy paths in the azimuth, elevation and diagonal planes, respectively. Figs.9a-9c show two-dimensional cross-sections through the three-dimensional volume shown in Fig.8, and Figs.10a-10c show the same cross-sections with the addition of the biopsy path 7 appropriate to each plane.

[0049] With the multi-position biopsy guide system according to embodiments of the present invention, it is the ability of the 2D matrix transducer to view the other planes or the 3D view that make the multiple biopsy needle guide locations useful. Biopsy guidance in three dimensions may also provide better awareness of nearby structures and help to avoid mistakes during the procedure.

[0050] Finally, it should be noted that the biopsy paths in the different imaging planes shown for example in Figs. 10a-10c are all at different angles to pass through the lesion 8. Accordingly, it is useful to provide biopsy needle guides 5 which may be adapted to variable angles of the biopsy path.

[0051] It should be noted that the above-mentioned embodiments illustrate rather than limit the invention, and that those skilled in the art will be able to design many alternative embodiments without departing from the scope of the appended claims. The term "comprising" does not exclude other elements or steps and the term "a" or "an" does not exclude a plurality of elements. It should also be noted that reference signs in the claims should not be construed as limiting the scope of the claims. The invention may be implemented by means of hardware comprising several distinct elements, and/or by means of a suitably programmed processor. The mere fact that certain measures are recited in mutually different dependent claims does not indicate that a combination of these measures cannot be used to advantage.

List of reference signs

[0052]

3 2D matrix ultrasound transducer

5	Biopsy needle guide
7	Biopsy path
5 8	Lesion
9	Transducer elements
10	Image plane
10 100	biopsy guide
103	Ultrasound transducer
15 104	Transducer face
105	Biopsy needle guide
106	Bracket
20 107	Biopsy path
108	Lesion
25 109	Transducer elements
110	Imaging plane

30 **Claims**

1. A multiposition biopsy guide system, comprising:
  - a 2D matrix ultrasound transducer (3); **characterized in that** the system further comprises at least two biopsy needle guides (5) for guiding at least two biopsy needles along biopsy paths (7) extending in different planes; the multiposition biopsy guide system being adapted to controllably guide the biopsy needles along biopsy paths (7) at variable locations with respect to the 2D matrix ultrasound transducer (3), and to acquire ultrasound images in respective image planes (10) for each of the biopsy needle guides, wherein the image planes are aligned with the biopsy paths (7) of each of the biopsy needle guides (5).
2. The multiposition biopsy guide system according to claim 1, wherein the 2D matrix ultrasound transducer (3) is adapted to acquire ultrasound images in an image plane (10), which image plane is controllably variable.
3. The multiposition biopsy guide system according to claim 1 or 2, wherein the multiposition biopsy guide system is

adapted to mount the biopsy needle guides (5) in variable locations with respect to the 2D matrix ultrasound transducer (3).

4. The multiposition biopsy guide system according to one of claims 1 to 3, wherein the multiposition biopsy guide system is adapted to determine the locations of the biopsy needle guides (5) with respect to the 2D matrix ultrasound transducer (3).
5. The multiposition biopsy guide system according to claim 4, wherein the multiposition biopsy guide system is adapted to acquire ultrasound images in image planes (10) aligned with the biopsy paths (7) corresponding to the determined locations of the biopsy needle guides (5).
6. The multiposition biopsy guide system according to claims 1 to 5, wherein the biopsy needle guide (5) is adapted for guiding the biopsy needles along biopsy paths (7) at controllably variable angles.
7. The multiposition biopsy guide system according to one of claims 1 to 6, wherein the biopsy needle guides (5) are adapted for guiding different types of biopsy needles.
8. The multiposition biopsy guide system according to one of claims 1 to 7, wherein the 2D matrix ultrasound transducer (3) is adapted to acquire 3D ultrasound images.
9. A biopsy arrangement comprising:
  - a multiposition biopsy guide system according to one of claims 1 to 8; and
  - a display device for displaying ultrasound images acquired by the 2D matrix ultrasound transducer.
10. A method of monitoring guidance of at least two biopsy needles along biopsy paths (7) using the multiposition biopsy guide system according to one of claims 1 to 8, the method comprising:
  - determining locations of the at least two biopsy needle guides (5) with respect to the 2D matrix ultrasound transducer (3); and
  - acquiring ultrasound images in image planes (10) aligned with the biopsy path (7) corresponding to the determined locations of the biopsy needle guides (5).

## Patentansprüche

1. Multipositions-Biopsieführungssystem, das Folgen-

des umfasst:

- einen 2D-Matrix-Schallkopf (3),  
**dadurch gekennzeichnet, dass** das System ferner Folgendes umfasst:  
zumindest zwei Biopsienadelführungen (5) zur Führung von zumindest zwei Biopsienadeln entlang von Biopsiewegen (7), die in verschiedenen Ebenen verlaufen,  
wobei das Multipositions-Biopsieführungssystem für die kontrollierte Führung der Biopsienadel entlang von Biopsiewegen (7) an verschiedenen Positionen hinsichtlich des 2D-Matrix-Schallkopfes (3) und für die Erfassung von Ultraschallbildern in entsprechenden Bildebenen (10) für jede der Biopsienadelführungen ausgelegt ist, wobei die Bildebenen zu den Biopsiewegen (7) jeder der Biopsienadelführungen (5) ausgerichtet sind.
2. Multipositions-Biopsieführungssystem nach Anspruch 1, wobei der 2D-Matrix-Schallkopf (3) für die Erfassung von Ultraschallbildern in einer Bildebene (10) ausgelegt ist, wobei die Bildebene kontrolliert variiert werden kann.
3. Multipositions-Biopsieführungssystem nach Anspruch 1 oder 2, wobei das Multipositions-Biopsieführungssystem für die Montage der Biopsienadelführungen (5) an verschiedenen Positionen hinsichtlich des 2D-Matrix-Schallkopfes (3) ausgelegt ist.
4. Multipositions-Biopsieführungssystem nach einem der Ansprüche 1 bis 3, wobei das Multipositions-Biopsieführungssystem für die Ermittlung der Positionen der Biopsienadelführungen (5) hinsichtlich des 2D-Matrix-Schallkopfes (3) ausgelegt ist.
5. Multipositions-Biopsieführungssystem nach Anspruch 4, wobei das Multipositions-Biopsieführungssystem für die Erfassung von Ultraschallbildern in Bildebenen (10) ausgelegt ist, die zu den Biopsiewegen (7) ausgerichtet sind, die den ermittelten Positionen der Biopsienadelführungen (5) entsprechen.
6. Multipositions-Biopsieführungssystem nach den Ansprüchen 1 bis 5, wobei die Biopsienadelführung (5) für die Führung der Biopsienadeln entlang von Biopsiewegen (7) unter kontrolliert variablen Winkeln ausgelegt ist.
7. Multipositions-Biopsieführungssystem nach einem der Ansprüche 1 bis 6, wobei die Biopsienadelführungen (5) für die Führung unterschiedlicher Arten von Biopsienadeln ausgelegt sind.

8. Multipositions-Biopsieführungssystem nach einem der Ansprüche 1 bis 7, wobei der 2D-Matrix-Schallkopf (3) für die Erfassung von 3D-Ultraschallbildern ausgelegt ist.

9. Biopsieanordnung, die Folgendes umfasst:

ein Multipositions-Biopsieführungssystem nach einem der Ansprüche 1 bis 8 und eine Anzeigevorrichtung zur Anzeige von durch den 2D-Matrix-Schallkopf erfassten Ultraschallbildern.

10. Verfahren zur Überwachung der Führung von zumindest zwei Biopsienadeln entlang von Biopsiewegen (7) anhand des Multipositions-Biopsieführungssystems nach einem der Ansprüche 1 bis 8, wobei das Verfahren Folgendes umfasst:

Ermitteln von Positionen der zumindest zwei Biopsienadelführungen (5) hinsichtlich des 2D-Matrix-Schallkopfes (3) und Erfassen von Ultraschallbildern in Bildebenen (10), die zu dem Biopsieweg (7) ausgerichtet sind, der den ermittelten Positionen der Biopsienadelführungen (5) entspricht.

## Revendications

1. Système de guides de biopsie à plusieurs positions, comprenant :

un transducteur ultrasonore à matrice bidimensionnelle (3) ;

**caractérisé en ce que** le système comprend en outre :

au moins deux guides d'aiguilles de biopsie (5) pour guider au moins deux aiguilles de biopsie le long de voies de biopsie (7) s'étendant dans des plans différents ;

le système de guides de biopsie à plusieurs positions étant apte à guider de manière contrôlable les aiguilles de biopsie le long de voies de biopsie (7) à des emplacements variables par rapport au transducteur ultrasonore à matrice bidimensionnelle (3), et à acquérir des images ultrasonore dans des plans d'images respectifs (10) pour chacun des guides d'aiguilles de biopsie, dans lequel les plans d'images sont alignés avec les voies de biopsie (7) de chacun des guides d'aiguilles de biopsie (5).

2. Système de guides de biopsie à plusieurs positions selon la revendication 1, dans lequel le transducteur ultrasonore à matrice bidimensionnelle (3) est apte à acquérir des images ultrasonores dans un plan d'image (10), ledit plan d'image étant variable de ma-

nière contrôlable.

3. Système de guides de biopsie à plusieurs positions selon la revendication 1 ou 2, dans lequel le système de guides de biopsie à plusieurs positions est apte à monter les guides d'aiguilles de biopsie (5) à des emplacements variables par rapport au transducteur ultrasonore à matrice bidimensionnelle (3).

4. Système de guides de biopsie à plusieurs positions selon l'une quelconque des revendications 1 à 3, dans lequel le système de guides de biopsie à plusieurs positions est apte à déterminer les emplacements des guides d'aiguilles de biopsie (5) par rapport au transducteur ultrasonore à matrice bidimensionnelle (3).

5. Système de guides de biopsie à plusieurs positions selon la revendication 4, dans lequel le système de guides de biopsie à plusieurs positions est apte à acquérir des images ultrasonores dans des plans d'images (10) alignés avec les voies de biopsie (7) correspondant aux emplacements déterminés des guides d'aiguilles de biopsie (5).

6. Système de guides de biopsie à plusieurs positions selon l'une quelconque des revendications 1 à 5, dans lequel le guide d'aiguilles de biopsie (5) est apte à guider les aiguilles de biopsie le long de voies de biopsie (7) à des angles variables de manière contrôlable.

7. Système de guides de biopsie à plusieurs positions selon l'une quelconque des revendications 1 à 6, dans lequel les guides d'aiguilles de biopsie (5) sont aptes à guider différents types d'aiguilles de biopsie.

8. Système de guides de biopsie à plusieurs positions selon l'une quelconque des revendications 1 à 7, dans lequel le transducteur ultrasonore à matrice bidimensionnelle (3) est apte à acquérir des images ultrasonores tridimensionnelles.

9. Agencement de biopsie, comprenant :

un système de guides de biopsie à plusieurs positions selon l'une des revendications 1 à 8 ; et un dispositif d'affichage pour afficher des images ultrasonores acquises par le transducteur ultrasonore à matrice bidimensionnelle.

10. Procédé de surveillance de guidage d'au moins deux aiguilles de biopsie le long de voies de biopsie (7) en utilisant le système de guides de biopsie à plusieurs positions selon l'une des revendications 1 à 8, le procédé comprenant :

la détermination d'emplacements d'au moins deux guides d'aiguilles de biopsie (5) par rapport au transducteur ultrasonore à matrice bidimensionnelle (3) ; et

l'acquisition d'images ultrasonore dans des plans d'images (10) alignés avec la voie de biopsie (7) correspondant aux emplacements déterminés des guides d'aiguilles de biopsie (5).

10

15

20

25

30

35

40

45

50

55

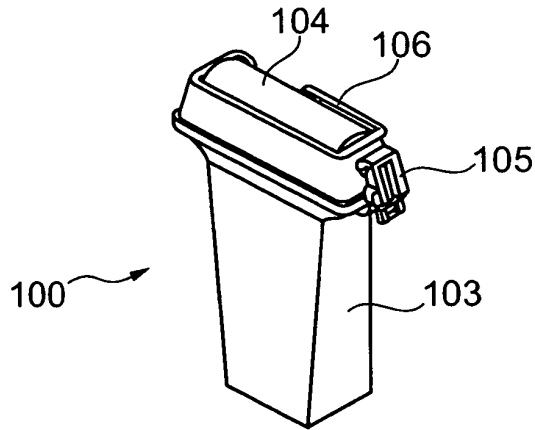

Fig. 1  
(prior art)

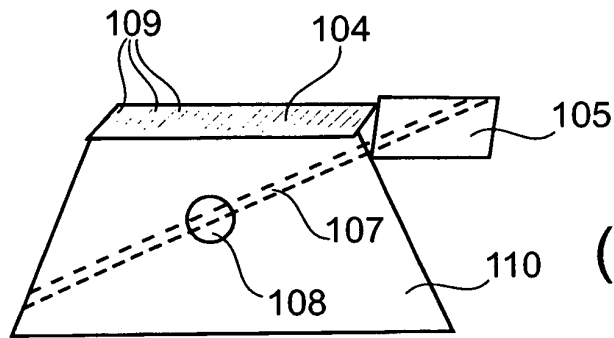

Fig. 2  
(prior art)

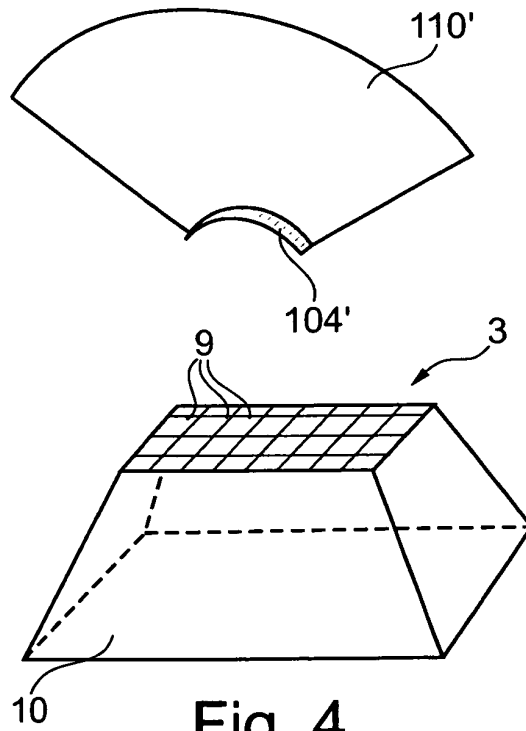

Fig. 3  
(prior art)

Fig. 4

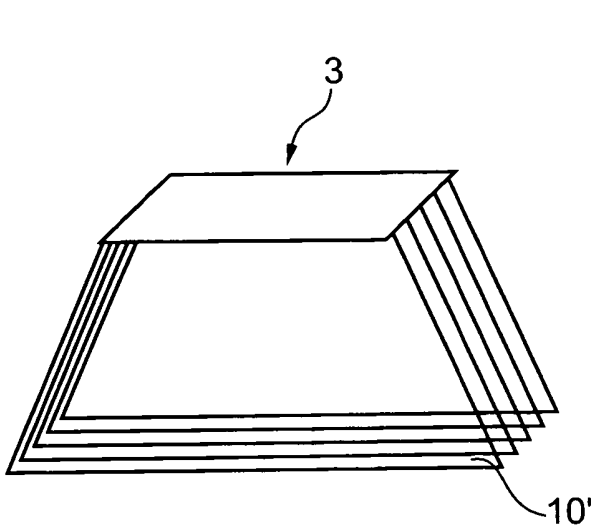

Fig. 5a

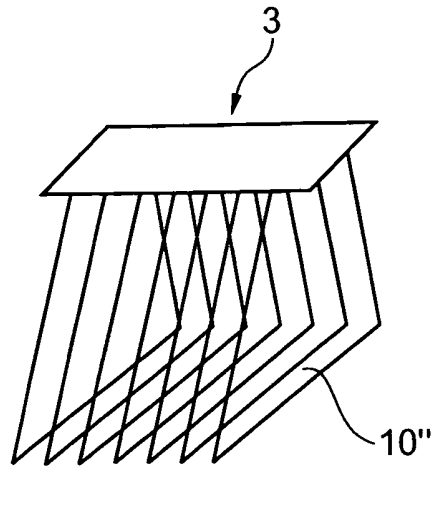

Fig. 5b

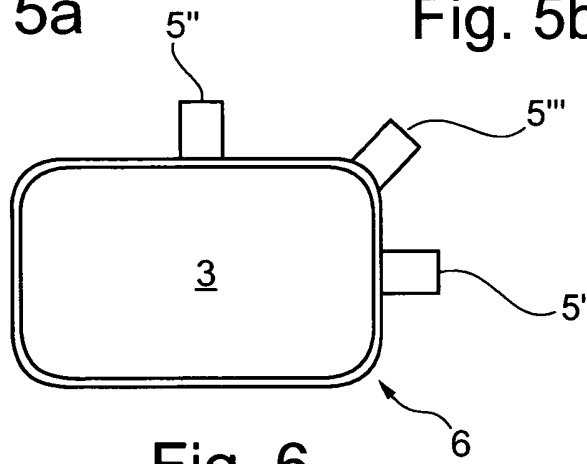

Fig. 6

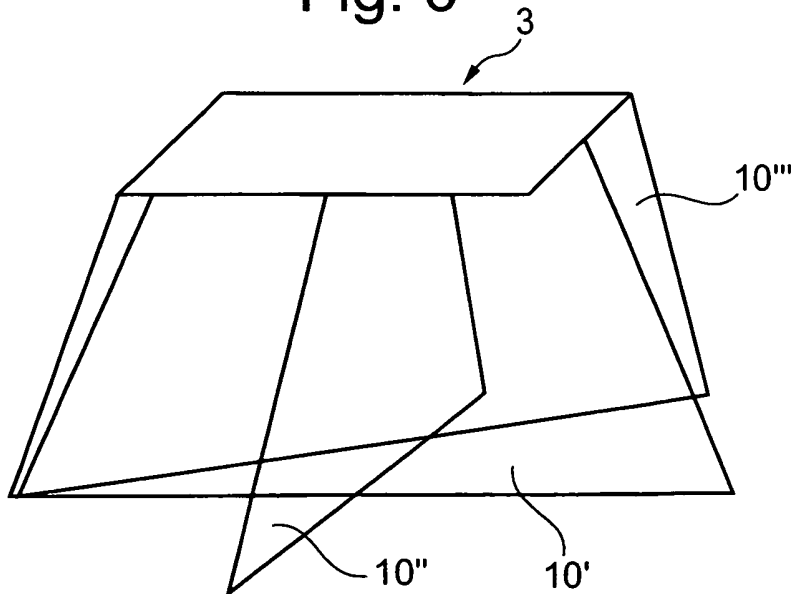

Fig. 7

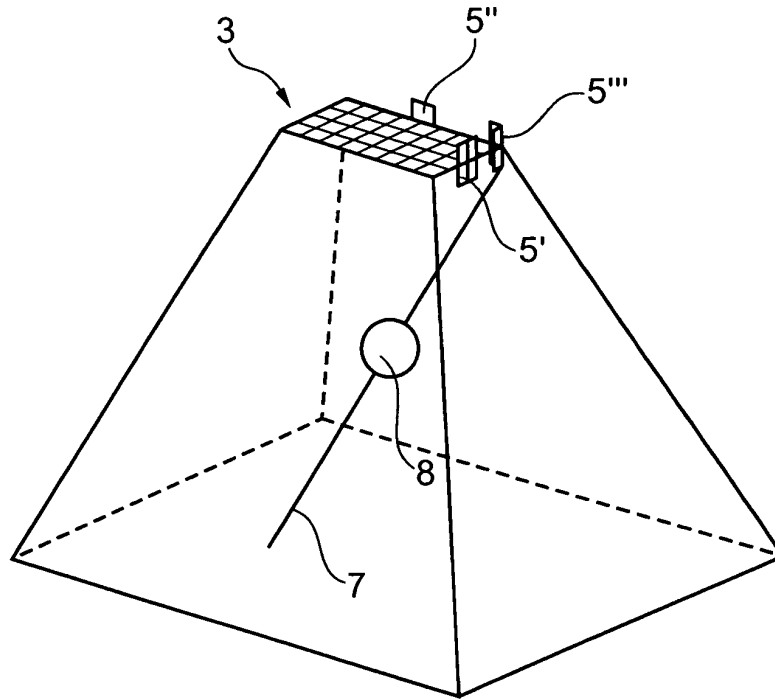

Fig. 8

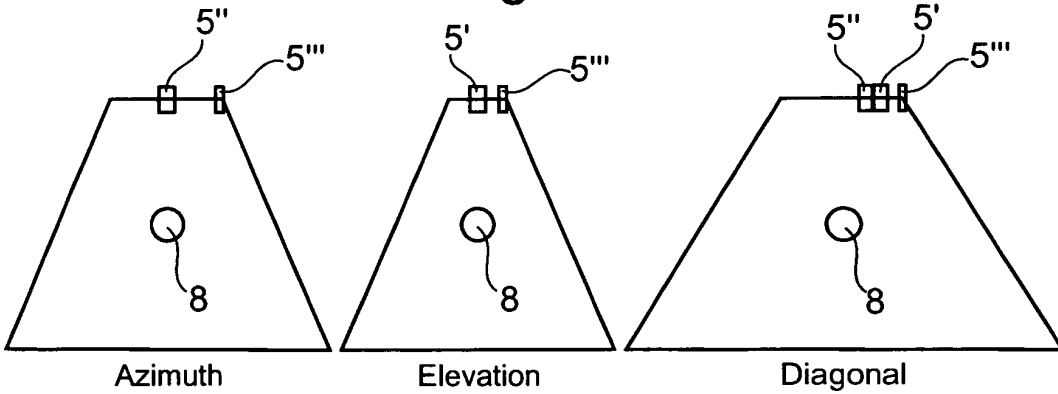

Fig. 9a

Fig. 9b

Fig. 9c

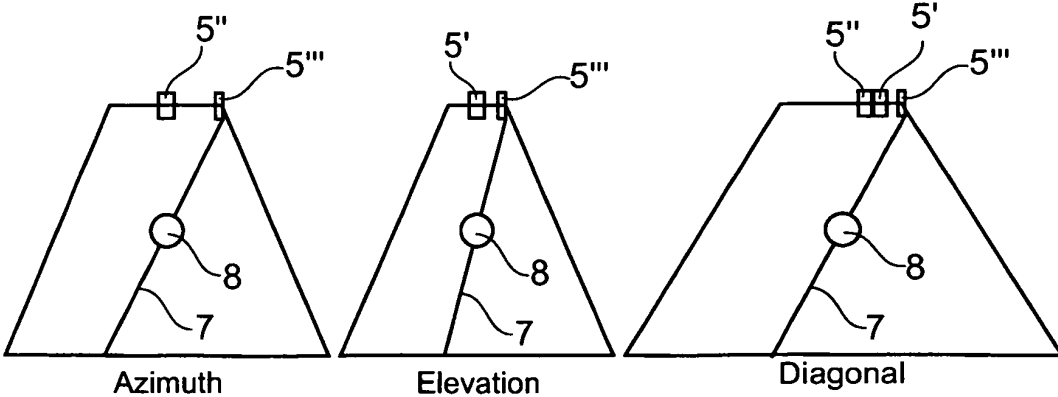

Fig. 10a

Fig. 10b

Fig. 10c

**REFERENCES CITED IN THE DESCRIPTION**

*This list of references cited by the applicant is for the reader's convenience only. It does not form part of the European patent document. Even though great care has been taken in compiling the references, errors or omissions cannot be excluded and the EPO disclaims all liability in this regard.*

**Patent documents cited in the description**

- WO 2006060657 A2 **[0004]**
- US 20020173719 A1 **[0011]**
- EP 1804079 A2 **[0012]**
- US 20020156376 A1 **[0013]**

专利名称(译)	具有超声换能器的活组织检查导向系统及其使用方法		
公开(公告)号	<a href="#">EP2424440B1</a>	公开(公告)日	2014-01-08
申请号	EP2010725868	申请日	2010-04-23
[标]申请(专利权)人(译)	皇家飞利浦电子股份有限公司		
申请(专利权)人(译)	皇家飞利浦电子N.V.		
当前申请(专利权)人(译)	皇家飞利浦N.V.		
[标]发明人	ROBINSON ANDREW L		
发明人	ROBINSON, ANDREW L.		
IPC分类号	G01S15/89 G01S7/52 A61B8/08 A61B17/34		
CPC分类号	A61B17/3403 A61B8/0833 A61B8/0841 A61B8/483 A61B2017/3413 G01S7/52073 G01S7/52074 G01S15/8993		
优先权	61/173285 2009-04-28 US		
其他公开文献	EP2424440A1		
外部链接	<a href="#">Espacenet</a>		

摘要(译)

提出了一种多位置活组织检查引导系统和使用这种活检引导系统的方法。活组织检查引导系统包括2D矩阵超声换能器(3)并且包括至少一个活检针引导件(5)，其适于沿活检路径(7)引导活检针。其中，多位置活检导向系统适于相对于2D矩阵超声换能器在可变位置处沿活检路径可控制地引导活检针。优选地，可以确定活检针引导件(5)相对于矩阵超声换能器的位置，并且可以获取与对应于所确定的活检针引导件的位置的活检路径对准的图像平面中的超声图像。因此，可以针对引导的活检针的各种位置和取向监测活组织检查过程。

