



(12) **EUROPEAN PATENT SPECIFICATION**

(45) Date of publication and mention
of the grant of the patent:
21.07.2004 Bulletin 2004/30

(51) Int Cl.⁷: **A61B 8/06**, A61B 8/08,
G01S 15/89, G01S 7/52

(21) Application number: **00991603.2**

(86) International application number:
PCT/EP2000/012764

(22) Date of filing: **13.12.2000**

(87) International publication number:
WO 2001/047421 (05.07.2001 Gazette 2001/27)

(54) **ULTRASONIC IMAGE PROCESSING METHOD AND SYSTEM FOR DISPLAYING AN
ULTRASONIC COLOR-CODED IMAGE SEQUENCE OF AN OBJECT HAVING MOVING PARTS**

ULTRASCHALLBILDVERARBEITUNGSVERFAHREN UND -SYSTEM ZUR DARSTELLUNG EINER
FARBKODIERTEN ULTRASCHALLBILSEQUENZ EINES KÖRPERS MIT BEWEGLICHEN TEILEN

PROCEDE ET SYSTEME DE TRAITEMENT D'IMAGES ULTRASONORES POUR AFFICHER UNE
SEQUENCE D'IMAGE A CODAGE COULEUR D'UN OBJET POURVU DE PARTIES MOBILES

(84) Designated Contracting States:
DE FR GB NL

(56) References cited:
WO-A-99/25250 **US-A- 5 355 887**
US-A- 5 797 843 **US-A- 5 800 356**
US-A- 5 882 315

(30) Priority: **28.12.1999 EP 99403309**

(43) Date of publication of application:
05.12.2001 Bulletin 2001/49

(73) Proprietor: **Koninklijke Philips Electronics N.V.**
5621 BA Eindhoven (NL)

• **BONNEFOUS O ET AL: "NON INVASIVE
ECHOGRAPHIC TECHNIQUES FOR ARTERIAL
WALL CHARACTERIZATION" PROCEEDINGS
OF THE IEEE ULTRASONICS
SYMPOSIUM,US,NEW YORK, IEEE, 3 November
1996 (1996-11-03), pages 1059-1064,
XP000753520 ISBN: 0-7803-3616-X**

(72) Inventor: **BONNEFOUS, Odile**
NL-5656 AA Eindhoven (NL)

(74) Representative: **Lottin, Claudine**
Philips Corporate Intellectual Property,
156 Boulevard Haussmann
75008 Paris (FR)

Description

[0001] The invention relates to an ultrasonic image processing method for displaying an ultrasonic examination color-coded image sequence of an object having moving parts in a medium. The invention also relates to an ultrasonic examination imaging system for carrying out this method.

[0002] The invention is used in the field of ultrasonic diagnostic imaging, for providing cardio-vascular non-invasive diagnostic tools for studying anomalies of arteries and notably stenoses. A basic diagnostic criterion for a stenosis is an abrupt reduction of the diameter of a suspect artery segment observed in an artery image. A more elaborate criterion is the study of the artery wall displacements in function of the instants of the cardiac cycle and in function of the location along the artery segment. Therefore, in order to early diagnosing stenosed arteries, the medical field has a need for non-invasive means for providing artery images together with readily visible indications related to the arterial wall displacements.

[0003] An ultrasonic image processing method for calculating wall displacements of an artery segment is already known from the patent US-05,579,771 (Bonnefous, Dec. 3, 1996). This document describes a method for characterizing an artery segment by ultrasonic imaging, using an array of ultrasonic transducers that produces a sectional frame, which is formed by image lines of a number of successive parallel excitation lines extending perpendicularly to the artery axis. Said array is coupled to a transmitter/receiver circuit, which provides high frequency signals to a signal processing system. Said system determines the arterial wall velocities and displacements, in the arterial radial direction Z, at a given location corresponding to an excitation line along the longitudinal X-axis of the artery, in function of excitation instants t, during a cardiac cycle. So, FIG.1 of this document shows a system in a block diagram form, apt to carry out this method.

[0004] An ultrasonic image processing method is known of WO 99/25250. This document describes a method for forming a first sequence of color-coded blood flow images, a second sequence of images where the shape and amplitude of artery wall displacements are represented by superimposed graphic lines and a third sequence of images composed of the synchronized combined first and second sequences.

[0005] An ultrasonic image processing method relating to 2-D displacements of organ walls is known of US5 355 887. This document describes a method for displaying the instants of the cardiac cycle when different points of a body organ wall reach a local maximum of displacement. This problem is solved by calculating the gradients of time of ultrasound data related to the body organ and displaying images for instance showing superimposed arrows relating to amplitude and direction of the time gradients.

[0006] So, under the influence of the pulsating wave of the blood in the artery during a cardiac cycle, the walls of the artery are subject to periodic radial movements whose amplitude and velocity can be determined. Depending on the state of the arterial walls, the pressure variations induced by the pulsating wave create either a uniform arterial dilatation or distorted parietal movements. Evaluating the distortions or non-distortions of the artery walls permits of deriving the presence and seriousness of stenosis, or elasticity defects, in real time, enabling optimization of the diagnosis. To that end, it is important to obtain information about the arterial wall movements and it is still more important to obtain information about the wall movement variations, i. e the movement gradients.

[0007] So, a problem lies in the fact that the movement gradients are not readily exploitable by a cardiologist. Not only the arterial wall movement variations must be made easily available and exploitable, but also, concomitantly, a standard grayscale image of the corresponding artery segment must be displayed, in order to perform a successful study and a precise diagnosis of the suspect zone of artery.

[0008] Now, a further problem lies in the fact that the gradient information, which is to be further added to the grayscale image, must not make this grayscale image unreadable.

[0009] These problems are solved by means of a method as claimed in Claim 1.

[0010] An advantage of this method is that the arterial wall behavior is made clearly visible together with the gradient information that is strongly related to arterial wall lesions and is most useful to establish the diagnosis. An other advantage is that non-invasive means are used, which permits of avoiding modification of the artery pressure, hence the actual wall movements, as would be the case using invasive means.

[0011] An ultrasonic diagnostic system having means for carrying out the method is claimed in Claim 7.

BRIEF DESCRIPTION OF THE FIGURES

[0012] Specific embodiments of the invention will be described in detail hereinafter with reference to the accompanying diagrammatic drawings ; therein :

FIG.1A, 1B, 1C show block diagrams of an ultrasonic diagnostic imaging system for carrying out a color-coded image sequence construction method; FIG.2A and 2B show respectively artery wall displacement and displacement gradient curves; and FIG.2C illustrates the construction of a color-coded image; FIG.3 shows an image constructed using the method.

DESCRIPTION OF THE PREFERRED EMBODIMENTS

[0013] Referring to FIG.1A and 1B, an ultrasonic diagnostic imaging system, shown in a block diagram form, is used as a tool for the examination of an artery 7 located in a medium 8 and comprises sub-systems 1, 100, 200 to perform an image processing method for the construction and display of a sequence of images, which permits of visualizing together:

an arterial segment whose walls have radial displacements occurring under the influence of the blood pressure, in function of the different time instants of a cardiac cycle,
and color-coded information related to the displacement variations along the longitudinal axis of the artery, as illustrated by FIG.3.

[0014] Referring to FIG.1A and FIG.1B, this image processing method comprises a step 1 of acquiring ultrasonic signals related to the artery segment, said artery segment having a longitudinal axis denoted X-axis and a radial axis denoted Z-axis, a step 100 of determining the arterial wall displacement gradients and a step 200 of constructing and displaying a sequence of color-coded images comprising a display of a grayscale image sequence representing said artery segment, in which specific zones of the arterial walls, are color-coded in function of the values of the wall displacement gradients. In the sequence of color-coded images, which is registered during a whole cardiac cycle, each image is acquired at a given instant n of said cardiac cycle.

[0015] The grayscale sequence images show that each arterial wall has radial displacements denoted $D(Z,X,n)$, from one image to the other; it means that a point situated on the internal boundary of the wall, at a given location X , is submitted to a displacement along the Z-axis. The color-coded representation of the specific zones of the walls, preferably in red, gives the information constituted by the local wall displacement variations, meaning the variation Δ of the estimated radial displacements $D(Z,X,n)$ around said location X .

[0016] Referring to FIG1A and 1B, the method of forming the sequence of ultrasonic color-coded images by forming an ultrasonic grayscale image sequence of the moving artery, where the zones of high movement gradients related to local high strains in the arterial walls are displayed in color, for example red, comprises the particular steps of :

acquisition 30 of the ultrasonic gray image sequence;
segmentation 62 of the gray image sequence to identify the arterial walls by determining transition lines 3a, 3b between the interior of the artery and the artery walls;
computation 68, 69 of the arterial wall displacements $D(Z,X,n)$ at each instant n ;

computation 71,73 of the wall displacement gradients $\Delta = d(D)/dX$ at each instant n ;

[0017] Illustrated by FIG.2C, this method further comprises a step 140 performing the normalization of the gray images on the location of arterial wall in order to solve a problem lying in that the ultrasonic grayscale image must remain visible when the specific zones are colored; this step comprises sub-steps of making whiter the boundary zones of the artery walls and assuring sufficient transparency of the colored zones, wherein :

evaluation of ribbon-shaped zones P1, P2 spanning both sides of each transition line 3a, 3b, for instance 1 mm each side, that is 2mm wide and computation of the mean gray values denoted G_{mean} for each pixel in the ribbon-shaped zones, which is performed by evaluating the mean gray value on each excitation line L parallel to the Z-axis in said zones; estimation of new gray values G for each pixel in the ribbon-shaped zones P1, P2, based on the original gray values denoted G_0 , taking into account the mean gray values G_{mean} , in order to reinforce the white in said zones, for example using the following formula in an image supposed to have 256 gray levels : $G = 128 (G_0 / G_{mean})$. As G is made larger, the image in made whiter in the ribbon-shaped zones.

[0018] Illustrated by FIG.3, the step 140 of the method further performs coloring the points in said ribbon-shaped zones P1, P2 in function of the displacement gradients. Before coloring the zones, the gray value of each point results of the association of three color components as follows : $G = V = B = R$ where G is for gray, V for green, B for blue and R for red. For coloring of the gradient zones, the level of each color component is modified as follows : $R = G$, $V = G (1 - \Delta/256)$, $B = G (1 - \Delta/256)$, if the number of gray-levels is 256, so as a point in the boundary zone has a color C given by associating the new levels of the components R, V, B. Other color-coding methods are possible to those skilled in the art. However, the proposed method gives good results for studying the displacement variations based on the display of the artery grayscale images with color-coded wall displacement gradients. FIG.3 illustrates a resulting image by representing the different color-coded zones by different striped zones Q1 to Q7, corresponding to different displacement gradients.

[0019] FIG.1A shows the ultrasonic diagnostic imaging system for the formation and display of the sequences of composite images as above-described, comprising the display of grayscale images with color-coded information of the movement gradients of the artery walls over at least one cardiac cycle. So, this ultrasonic diagnostic imaging system constitutes a tool for the diagnosis of lesions of arterial walls. This ultrasonic diagnostic imaging system comprises sub-systems 1, 100, 200.

[0020] Referring to Fig.1A, the operation of the sub-system 1 involves an ultrasonic probe 10 in contact with the medium 8 observed. The ultrasonic probe 10 transmits, via periodic excitations, ultrasonic signals to the medium scanned, in a direction OZ, and receives, in the same direction OZ, the echoes returned by the obstacles encountered in the medium. The probe is preferably composed of ultrasonic transducers which are assembled in a linear array parallel to the X-axis. A respective excitation line corresponds to each transducer.

[0021] Referring to Fig.1B, the examination of the medium by the ultrasonic probe 10 is performed in such a manner that the artery 7 is scanned longitudinally in the direction parallel to OX in order to obtain longitudinal cross-sectional intensity images, enabling the visualization of the front wall 2a and the rear wall 2b. The direction of the transducer array is represented by the direction OX and the direction of the excitation lines is represented by the direction OZ. Therefore, the echographic image is scanned along the excitation lines of direction OZ which are the columns of the image. The probe is connected in 19 to an emitter/receiver stage 20. In a transmission step, the medium is scanned along the directions of the excitation lines. In a receiving step, the image of each excitation line is formed, taking into account the propagation time in the medium and the amplitude of the echoes returned by the obstacles encountered along the excitation line considered. Preferably, in order to obtain a suitable resolution for the image, the ultrasonic excitations are focused during transmission as well as reception. The emitter/receiver stage 20 provides acoustic high-frequency signals $S(X,Z,n)$ which enable the formation, as a function of the instant n , of a sequence of intensity images $I(X,Z,n)$ by way of an operation 30, n being the number of the image of the sequence. Each intensity image $I(X,Z,n)$ 21 is thus formed by the scanning of the excitation lines of the probe. The behavior of the artery is observed at least over a full cardiac cycle. Therefore, a sequence of a number N of images covering a time interval which is at least equal to a cardiac cycle is formed, N being a number $1 \leq N$. The number of image excitation lines may be, for example 68 or 112 with a scanning step (distance between excitation lines) of 0.5 mm or 0.25 mm. These characteristics enable visualization of an arterial segment of 28 mm.

[0022] Referring to FIG.1A, the intensity images $I(X,Z,n)$ 21 referred to as grayscale images are stored in an image memory 50 denoted Cinelooop for further construction of the display of color-coded images. For the evaluation of the displacement gradients, it is necessary to determine the velocity and the amplitude of the displacements of the walls.

[0023] The sub-system 100 includes a processor which executes the steps of processing the high-frequency signals $S(X,Z,n)$. The sub-system 100 first performs a temporal correlation operation 120. The successive ultrasonic echoes are compared by way of their cor-

relation function. The displacement of the biological structures from one ultrasonic emission to the next is estimated while taking into account the displacement of the correlation peak corresponding to the delay introduced by this displacement upon reception. For all objects scanned, the correlation operation 120 provides velocity measurements in the form of two-dimensional velocity images $V(X,Z,n)$ denoted 121. The correlation function is performed between the images of the image sequence. So, a rather large memory 119 denoted MEM3 must be available at the input of the module 120 performing the correlation operation for providing the necessary delay between two correlated signals.

[0024] Besides the velocity images 121 $V(X,Z,n)$, echo amplitude images 111 $A(X,Z,n)$, used as segmentation means, are also necessary to perform the further extraction and localization of the parietal velocities of the two-dimensional velocity images. These amplitude images 111 $A(X,Z,n)$ are obtained, in the sub-system 100, by means of an amplitude measurer 110. The memory 122 called MEM1 and the memory 112 called MEM2 store the results of the sub-system 100, which are respectively the velocity images $V(X,Z,n)$ and the echo amplitude images $A(X,Z,n)$.

[0025] Referring to FIG.1C, the sub-system 200 comprises a processor, which executes the post-processing operation 130 applied to the results of the preceding operations 110 and 120 in order to determine the upper and lower wall displacements respectively $D1(X,n)$ and $D2(X,n)$, and the corresponding displacement gradients $\Delta1(X,n)$, $\Delta2(X,n)$. The operation 130 comprises steps of:

application 62 of an adaptable threshold for each amplitude image 111 $A(X,Z,n)$ in order to perform the identification of the internal parietal boundary of the artery : this threshold produces digital images with black/white transitions between the interior and the exterior of the artery corresponding to the lower and upper internal parietal boundaries 3a, 3b; these transitions are filtered to eliminate discontinuities; determination 63 of the respective thickness of each arterial walls. In the current implementation, a thickness value amounts to approximately 1 mm; determination 66, 67 of an average value of the velocities through the thickness of the arterial wall, for example through the given thickness of 1 mm; determination 68, 69 of the displacements $D1(X,n)$ and $D2(X,n)$ between each image, related to each wall, by a temporal integration, such as shown by the curve of FIG.2A; and determination of the corresponding displacement gradients $\Delta1(X,n)$, $\Delta2(X,n)$ for each wall, calculated by an adder 71 as the difference between two displacement values, such as shown by the curve of FIG.2B.

[0026] After corrections in 73, taking into account the starting instants $n1$, $n2$ of the cardiac cycles determined in 72, where the artery has zero parietal displacements,

the display sequence images, as shown in FIG.3, are constructed by the module 140, which constructs the color-coded zones corresponding to the parietal displacement gradients $\Delta 1(X,n)$, $\Delta 2(X,n)$ at the instant n in the grayscale images $I(X,Z,n)$ fetched from the memory 50 Cineloop.

[0027] Referring to FIG. 1A, the ultrasonic processing system also comprises an interface 170 for the user to control the display of the images of the sequence in function of the time instants n . The display system, the processors and the memories may respectively be the screen 40, the processor 130 and the memory of a workstation as known of those skilled in the art. The workstation may also comprise a keyboard and a mouse used as an interface for the user to control the image of the screen. A color display system is used to display the color-coded zones.

[0028] The invention can be applied to the processing of signals different from ultrasonic signals, for example electric, electromagnetic signals, etc, and to the processing of other objects other than an artery, for example objects having moving parts with regularly recurring displacements. During the display of the sequence on the display device 40, the physician can qualitatively and quantitatively evaluate the distortions or non-distortions of the displacements of the walls and derive therefrom the presence and the seriousness of stenosis, or elasticity defects, linked to the arterial walls of the adjacent grayscale image, in real time, which enables optimization of the diagnosis.

Claims

1. Ultrasonic image processing method, comprising steps of:
 - acquiring ultrasonic signals related to an object having moving parts in a medium; constructing an ultrasonic grayscale 2-D image sequence representing a cross-section of a segment of the object with respect to a longitudinal axis (X) perpendicular to the grayscale image lines (Z); estimating the displacements and the displacement gradients of a boundary of the object and:
 - normalizing the gray levels in the boundary zone and color-coding the points of the boundary zone of the image sequence in function of the displacement gradients, in order to provide color-coded information of displacement variations of the object moving parts.
2. A method as claimed in Claim 1, wherein the grayscale image normalization step comprises sub-steps of segmentation of the grayscale images to determine a boundary transition line, estimation of

the boundary zone as a zone spanning each side of the boundary transition line, estimation of the mean gray (G_{mean}) level in the boundary zone and calculation of new gray values (G) for the points of the boundary zone, based on the estimated mean gray values and on the original gray values (G_0), which are in average whiter than the original gray values.

3. A method as claimed in Claim 2, wherein the new gray values G for the points of the boundary zone are estimating using the following relation : $G = 128 (G_0 / G_{\text{mean}})$ where G_0 is the original gray value and G_{mean} is the mean gray value on the corresponding line of the grayscale image in the boundary zone.
4. A method as claimed in Claim 2 or 3, wherein the color-coding step comprises sub-steps of estimating the new color of the points in the boundary zone by varying the levels of the color components (R, B, V) of the new gray color levels (G) at said points in function of the displacement gradients (Δ).
5. A method as claimed in Claim 4, wherein, each gray point being formed by association of three color components as follows : $G = V = B = R$ where G is for gray, V for green, B for blue and R for red, the levels of each color component is modified and the new levels are given by the following relations : $R = G$, $V = G (1 - \Delta/256)$, $B = G (1 - \Delta/256)$, if the number of gray-levels is 256, so as a point in the boundary zone has a new color C, preferably in the red, given by associating the new levels of the components R, V, B.
6. A method as claimed in any one of Claims 1 to 5, wherein the object is an artery, the moving parts are the artery walls moving under the blood pressure, the displacements are periodic due to the cardiac cycles, the grayscale image longitudinal axis (X) is the artery axis, the displacements are the radial arterial displacements and the gradients of wall displacement are color-coded, preferably in red, to provide information on the arterial wall displacement variations.
7. An ultrasonic examination imaging system comprising an ultrasonic probe coupled to an ultrasonic system for emitting and receiving ultrasonic signals from a medium with an object having moving parts, and comprising ultrasonic sub-systems to process the received ultrasonic signals with processors having processing means for carrying out the method of one of Claims 1 to 6, further comprising means to construct the color-coded images, memories to store the images, and a display system to display the color-coded images formed, said sub-systems comprising :

means for acquiring ultrasonic signals related to an object having moving parts in a medium; means for constructing an ultrasonic grayscale 2-D image sequence representing a cross-section of a segment of the object with respect to a longitudinal axis (X) perpendicular to the grayscale image lines (Z); means for estimating the displacements and the displacement gradients of a boundary of the object and means for normalizing the gray levels in the boundary zone and color-coding the points of the boundary zone of the image sequence in function of the displacement gradients, in order to provide color-coded information of displacement variations the object moving parts.

8. A system as claimed in Claims 7, wherein the display system is a color system.
9. A system as claimed in one of Claims 7 or 8, comprising a suitably programmed computer of a workstation or a special purpose processor having circuit means, which are arranged to process ultrasonic signals according to the method, said system having means to display the images constructed according to said method, and having an user interface such as a mouse or a keyboard to permit the user of controlling the display.
10. A computer program product comprising a set of instructions for carrying out a method as claimed in one of Claims 1 to 6, when said program product is run on a computer.

Patentansprüche

1. Ultraschallbildverarbeitungsverfahren, das folgende Schritte umfasst:

Erfassen von Ultraschallsignalen, die sich auf einen Körper mit beweglichen Teilen in einem Medium beziehen;
 Konstruieren einer Sequenz von 2D-Graustufen-Ultraschallbildern, die einen Querschnitt eines Segments des Körpers in Bezug auf eine Längsachse (X) darstellen, die senkrecht zu den Graustufenbildzeilen (Z) verläuft;
 Schätzen der Bewegungen und der Bewegungsgradienten einer Grenze des Körpers und
 Normalisieren der Graustufen in der Grenzzone und Farbcodieren der Punkte der Grenzzone der Bildsequenz als Funktion der Bewegungsgradienten, um farbcodierte Informationen der Bewegungsschwankungen der beweglichen Teile des Körpers zu schaffen.

2. Verfahren nach Anspruch 1, wobei der Schritt der Normalisierung der Graustufenbilder folgende Teilschritte umfasst: Segmentieren der Graustufenbilder zur Bestimmung einer Grenzübergangslinie, Schätzen der Grenzzone als eine Zone, die sich auf jeder Seite der Grenzübergangslinie erstreckt, Schätzen der mittleren Graustufe (G_{mean}) in der Grenzzone und Berechnen neuer Grauwerte (G) für die Punkte der Grenzzone auf der Grundlage der geschätzten mittleren Grauwerte und der ursprünglichen Grauwerte (G_0), die im Durchschnitt weißer als die ursprünglichen Grauwerte sind.
3. Verfahren nach Anspruch 2, wobei die neuen Grauwerte G für die Punkte der Grenzzone mittels der folgenden Beziehung geschätzt werden: $G = 128 (G_0/G_{\text{mean}})$, wobei G_0 der ursprüngliche Grauwert und G_{mean} der mittlere Grauwert auf der entsprechenden Zeile des Graustufenbildes in der Grenzzone ist.
4. Verfahren nach Anspruch 2 oder 3, wobei der Schritt der Farbcodierung folgende Teilschritte umfasst: Schätzen der neuen Farbe der Punkte in der Grenzzone durch Verändern der Stufen der Farbkomponenten (R, B, V) der neuen Graustufen (G) an den genannten Punkten als Funktion der Bewegungsgradienten (Δ).
5. Verfahren nach Anspruch 4, wobei wenn jeder Graupunkt durch Zuordnung von drei Farbkomponenten nach $G = V = B = R$ gebildet wird, wobei G für Grau, V für Grün, B für Blau und R für Rot steht, die Stufen jeder Farbkomponente verändert werden und sich die neuen Stufen aus den folgenden Beziehungen ergeben: $R = G$, $V = G (1-\Delta/256)$, $B = G (1-\Delta/256)$, wenn die Anzahl der Graustufen 256 beträgt, so dass ein Punkt in der Grenzzone eine neue Farbe C, vorzugsweise Rot, hat, die sich aus der Zuordnung der neuen Stufen der Komponenten R, V, B ergibt.
6. Verfahren nach einem der Ansprüche 1 bis 5, wobei der Körper eine Arterie ist, die beweglichen Teile die sich unter dem Blutdruck bewegenden Arterienwände sind, die Bewegungen aufgrund der Herzzyklen periodisch sind, die Längsachse (X) der Graustufenbilder die Arterienachse ist, die Bewegungen radiale Arterienbewegungen sind und die Gradienten der Wandbewegungen vorzugsweise in Rot farbcodiert werden, um Informationen über die Schwankungen der Arterienwandbewegungen zu liefern.
7. Ultraschalluntersuchungs-Bilddarstellungssystem, das eine Ultraschallsonde umfasst, die mit einem Ultraschallsystem verbunden ist, um Ultraschallsignale an ein Medium mit einem Körper mit beweg-

lichen Teilen zu senden und von ihm zu empfangen, und das Ultraschallsysteme umfasst, um die empfangenen Ultraschallsignale mit Prozessoren zu verarbeiten, die Verarbeitungsmittel zur Durchführung des Verfahrens nach einem der Ansprüche 1 bis 6 umfassen, und das ferner Mittel zum Konstruieren der farbcodierten Bilder, Speicher zum Speichern der Bilder und ein Anzeigesystem zum Anzeigen der erzeugten farbcodierten Bilder umfasst, wobei die genannten Subsysteme Folgendes umfassen:

Mittel zum Erfassen von Ultraschallsignalen, die sich auf einen Körper mit beweglichen Teilen in einem Medium beziehen;

Mittel zum Konstruieren einer Sequenz von 2D-Graustufen-Ultraschallbildern, die einen Querschnitt eines Segments des Körpers in Bezug auf eine Längsachse (X) darstellen, die senkrecht zu den Graustufenbildzeilen (Z) verläuft;

Mittel zum Schätzen der Bewegungen und der Bewegungsgradienten einer Grenze des Körpers und

Mittel zum Normalisieren der Graustufen in der Grenzzone und Farbcodieren der Punkte der Grenzzone der Bildsequenz in Abhängigkeit von den Bewegungsgradienten, um farbcodierte Informationen der Bewegungsschwankungen der beweglichen Teile des Körpers zu schaffen.

8. System nach Anspruch 7, wobei das Anzeigesystem ein Farbsystem ist.
9. System nach einem der Ansprüche 7 oder 8, das einen in geeigneter Weise programmierten Computer einer Workstation oder einen Spezialprozessor mit Schaltungsmitteln umfasst, die so ausgelegt sind, dass sie Ultraschallsignale gemäß dem Verfahren verarbeiten, wobei das genannte System über Mittel zum Anzeigen der gemäß dem genannten Verfahren konstruierten Bilder und über eine Benutzerschnittstelle wie eine Maus oder eine Tastatur verfügt, mit der der Benutzer die Anzeige steuern kann.
10. Computerprogrammprodukt, das einen Befehlssatz zur Ausführung eines Verfahrens nach einem der Ansprüche 1 bis 6 umfasst, wenn das genannte Programmprodukt auf einem Computer läuft.

Revendications

1. Procédé de traitement d'images ultrasonores, comprenant les étapes suivantes :

l'acquisition de signaux ultrasonores liés à un objet comportant des parties en mouvement dans un milieu ; la construction d'une séquence d'images bidimensionnelles à niveaux de gris ultrasonores représentant une coupe transversale d'un segment de l'objet par rapport à un axe longitudinal (X) perpendiculaire aux lignes de l'image à niveaux de gris (Z) ; l'estimation des déplacements et des gradients de déplacement d'une limite de l'objet, et la normalisation des niveaux de gris dans la zone limitrophe et le codage couleur des points de la zone limitrophe de la séquence d'images en fonction des gradients de déplacement, afin de fournir des informations à codage couleur des variations de déplacement des parties en mouvement de l'objet.

2. Procédé suivant la revendication 1, dans lequel l'étape de normalisation des images à niveaux de gris comprend les sous-étapes de segmentation des images à niveaux de gris pour déterminer une ligne de transition limitrophe, d'estimation de la zone limitrophe comme une zone s'étendant de chaque côté de la ligne de transition limitrophe, d'estimation du niveau de gris moyen (G_{mean}) dans la zone limitrophe et de calcul de nouvelles valeurs de gris (G) pour les points de la zone limitrophe, sur la base des valeurs de gris moyennes estimées et des valeurs originales de gris (G_0), qui sont en moyenne plus blanches que les valeurs originales de gris .
3. Procédé suivant la revendication 2, dans lequel les nouvelles valeurs de gris G pour les points de la zone limitrophe sont estimées en utilisant la relation suivante : $G = 128 (G_0 / G_{\text{mean}})$, où G_0 est la valeur originale de gris et G_{mean} est la valeur de gris moyenne sur la ligne correspondante de l'image à niveaux de gris dans la zone limitrophe.
4. Procédé suivant la revendication 2 ou 3, dans lequel l'étape de codage couleur comprend les sous-étapes d'estimation de la nouvelle couleur des points dans la zone limitrophe en faisant varier les niveaux des composantes de couleur (R, B, V) des nouveaux niveaux de couleur de gris (G) auxdits points en fonction des gradients de déplacement (Δ).
5. Procédé suivant la revendication 4, dans lequel, chaque point de gris étant formé par l'association de trois composantes de couleur comme suit : $G = V = B = R$, où G signifie gris, V vert, B bleu et R rouge, les niveaux de chaque composante de couleur sont modifiés et les nouveaux niveaux sont donnés par les relations suivantes : $R = G$, $V = G (1 - \Delta/256)$, $B = G (1 - \Delta/256)$, si le nombre de niveaux de gris est 256, de sorte qu'un point dans la

zone limitrophe présente une nouvelle couleur C, de préférence dans les rouges, donnée en associant les nouveaux niveaux des composantes R, V, B.

6. Procédé suivant l'une quelconque des revendications 1 à 5, dans lequel l'objet est une artère, les parties en mouvement sont les parois artérielles se déplaçant sous l'effet de la pression sanguine, les déplacements sont périodiques en raison des cycles cardiaques, l'axe longitudinal de l'image à niveaux de gris (X) est l'axe artériel, les déplacements sont les déplacements artériels radiaux et les gradients de déplacement pariétal sont codés en couleur, de préférence en rouge, pour fournir des informations concernant les variations de déplacement de paroi artérielle.
7. Système d'imagerie d'examen à ultrasons comprenant une sonde ultrasonore connectée à un système à ultrasons pour émettre et recevoir des signaux ultrasonores d'un milieu avec un objet comportant des parties en mouvement, et comprenant des sous-systèmes à ultrasons pour traiter les signaux ultrasonores reçus au moyen de processeurs comprenant des moyens de traitement pour exécuter le procédé suivant l'une quelconque des revendications 1 à 6, comprenant en outre des moyens pour construire les images à codage couleur, des mémoires pour stocker les images et un système d'affichage pour afficher les images à codage couleur formées, lesdits sous-systèmes comprenant :
- des moyens pour l'acquisition de signaux ultrasonores liés à un objet comportant des parties en mouvement dans un milieu ; des moyens pour la construction d'une séquence d'images bidimensionnelles à niveaux de gris ultrasonores représentant une coupe transversale d'un segment de l'objet par rapport à un axe longitudinal (X) perpendiculaire aux lignes d'image à niveaux de gris (Z) ; des moyens pour l'estimation des déplacements et des gradients de déplacement d'une limite de l'objet, et des moyens pour la normalisation des niveaux de gris dans la zone limitrophe et le codage couleur des points de la zone limitrophe de la séquence d'images en fonction des gradients de déplacement, afin de fournir des informations à codage couleur de variations de déplacement des parties en mouvement de l'objet.
8. Système suivant la revendication 7, dans lequel le système d'affichage est un système couleur.
9. Système suivant la revendication 7 ou 8, comprenant un ordinateur programmé de manière appropriée d'une station de travail ou un processeur spé-

cialisé comprenant des moyens de circuit, qui sont agencés pour traiter des signaux ultrasonores suivant le procédé, ledit système comprenant des moyens pour afficher les images construites suivant ledit procédé, et comprenant une interface utilisateur comme une souris ou un clavier pour permettre à l'utilisateur de contrôler l'affichage.

10. Produit sous la forme d'un programme informatique comprenant un jeu d'instructions pour exécuter un procédé suivant l'une quelconque des revendications 1 à 6 lorsque ledit produit sous la forme d'un programme est exécuté sur un ordinateur.

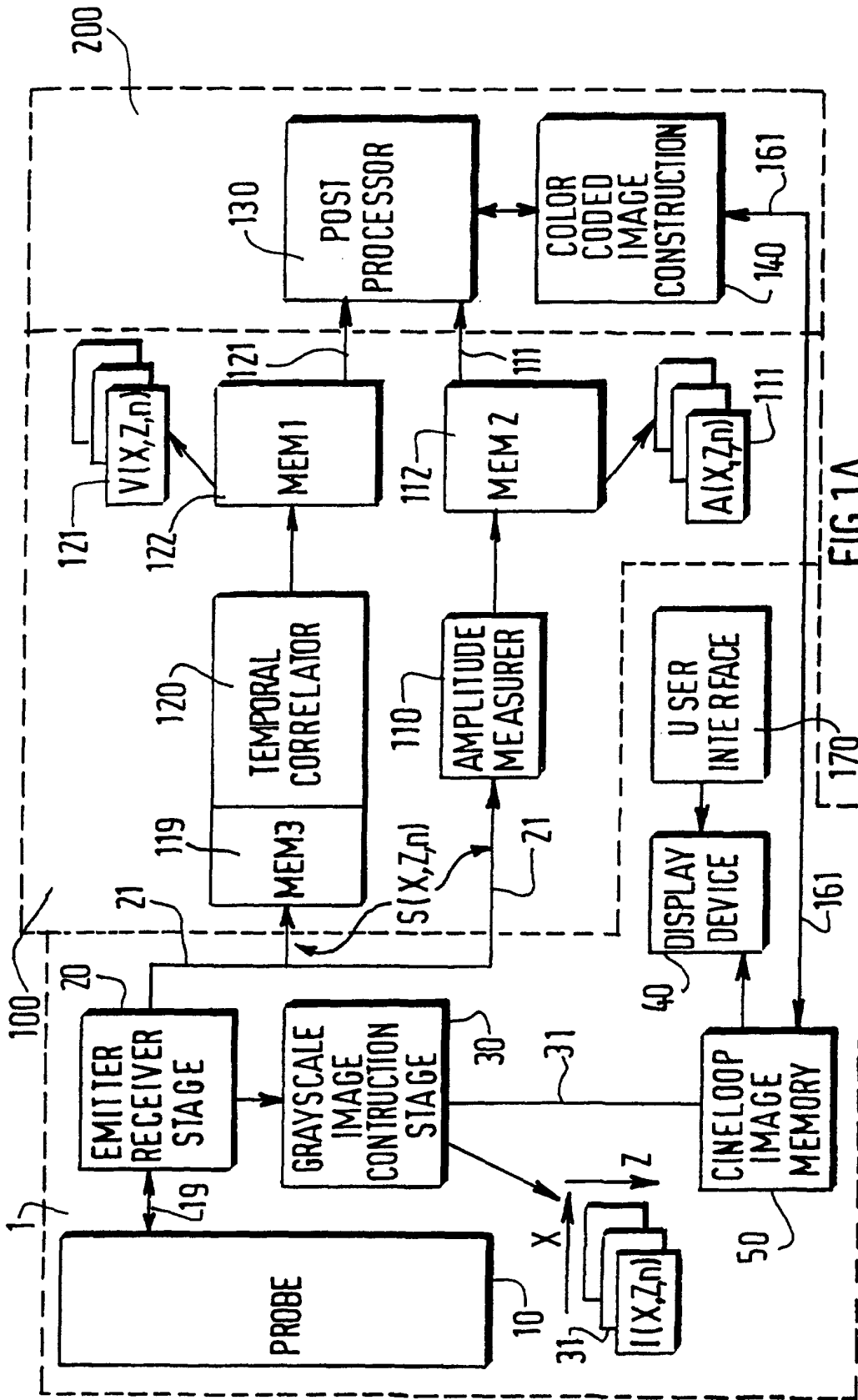
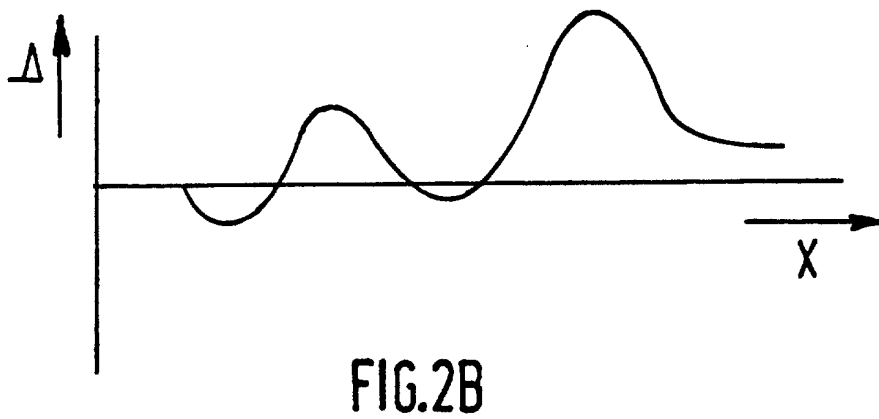
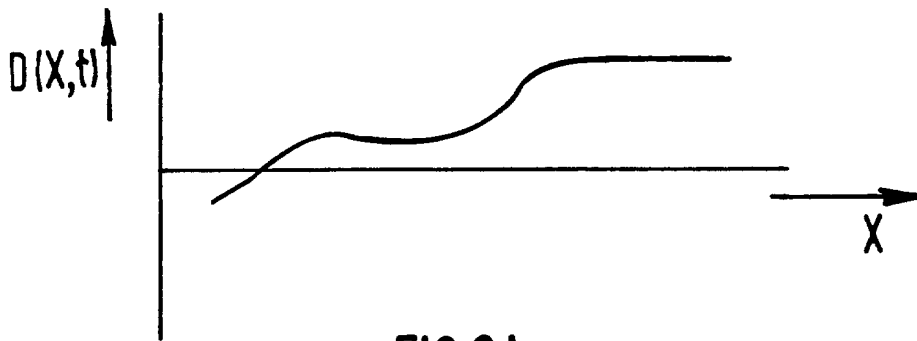
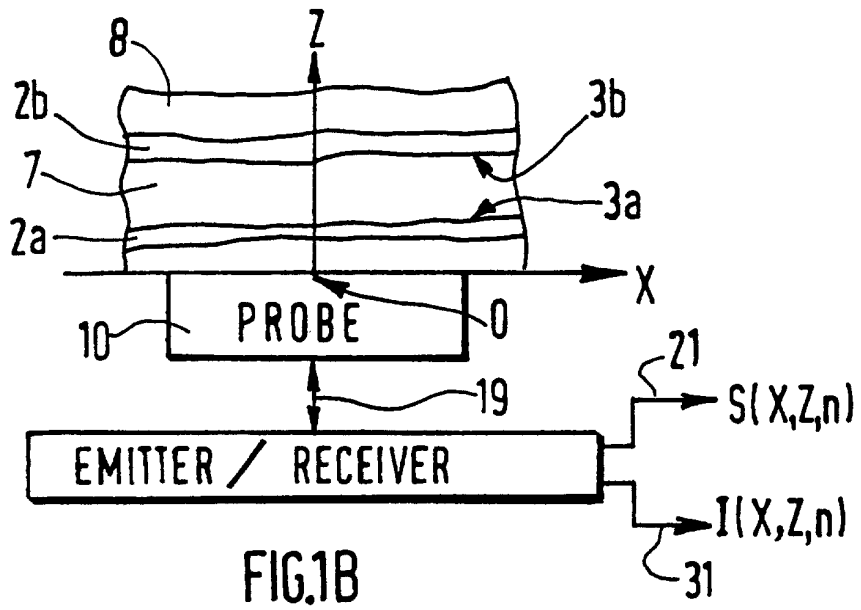

FIG. 1A



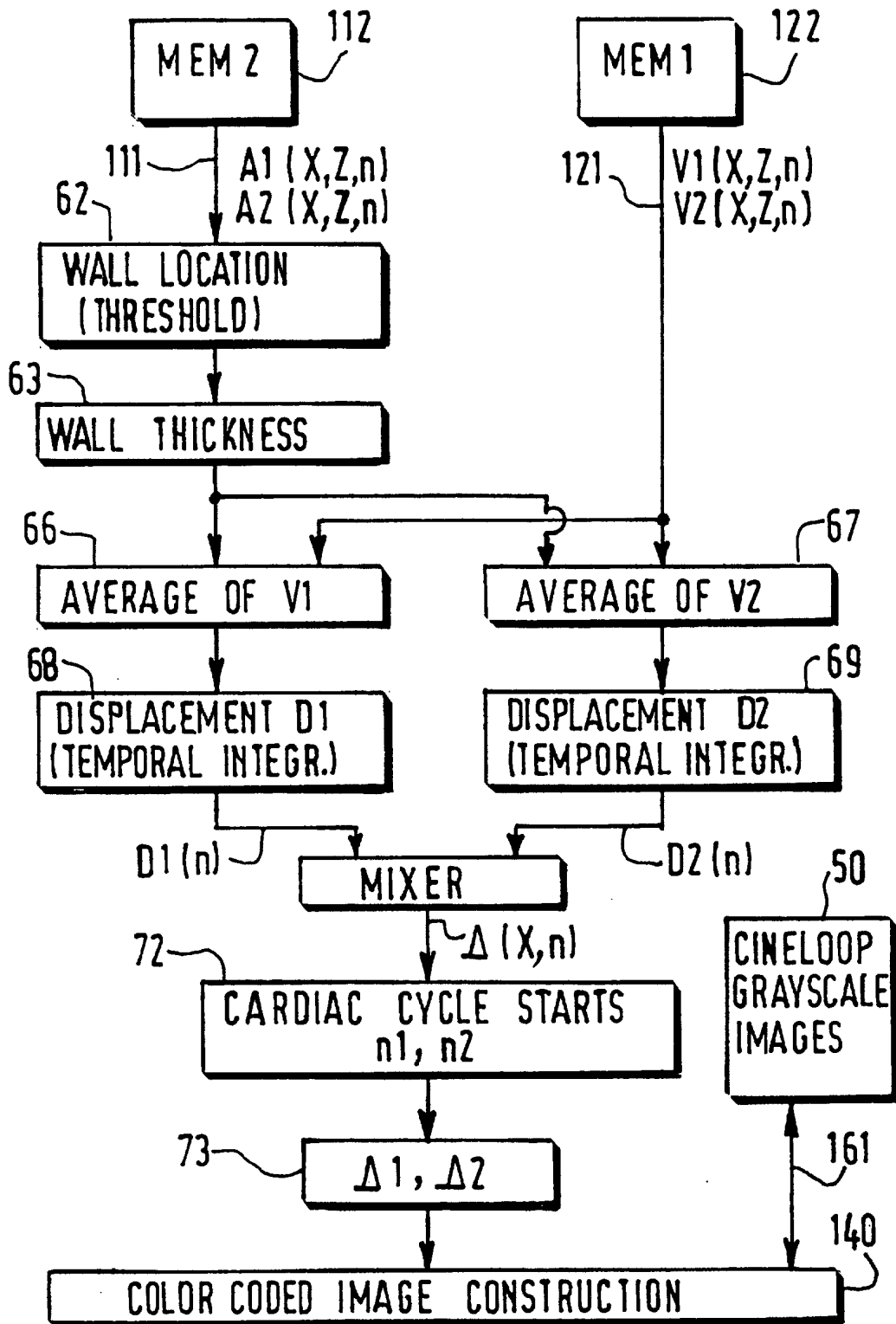

FIG.1C

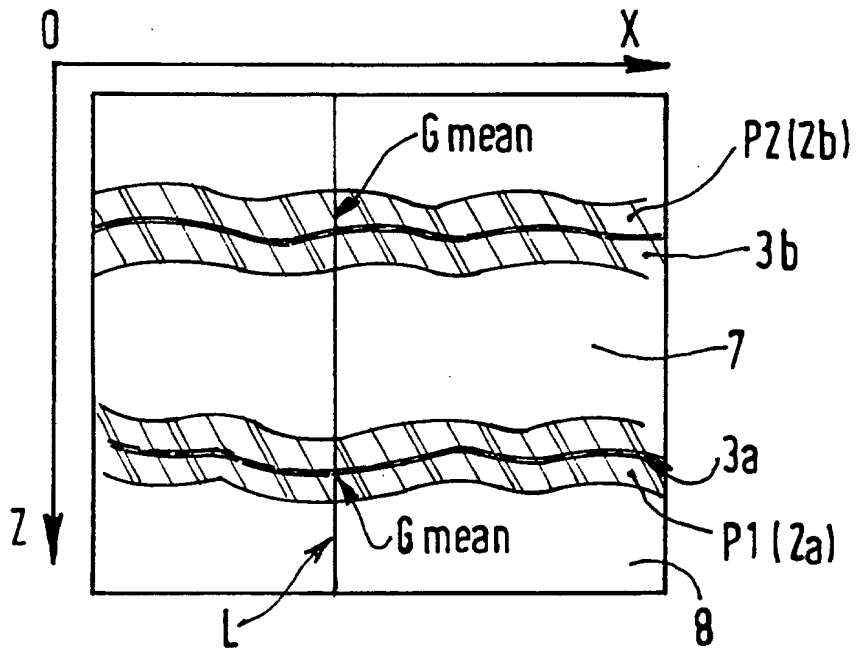

FIG. 2C

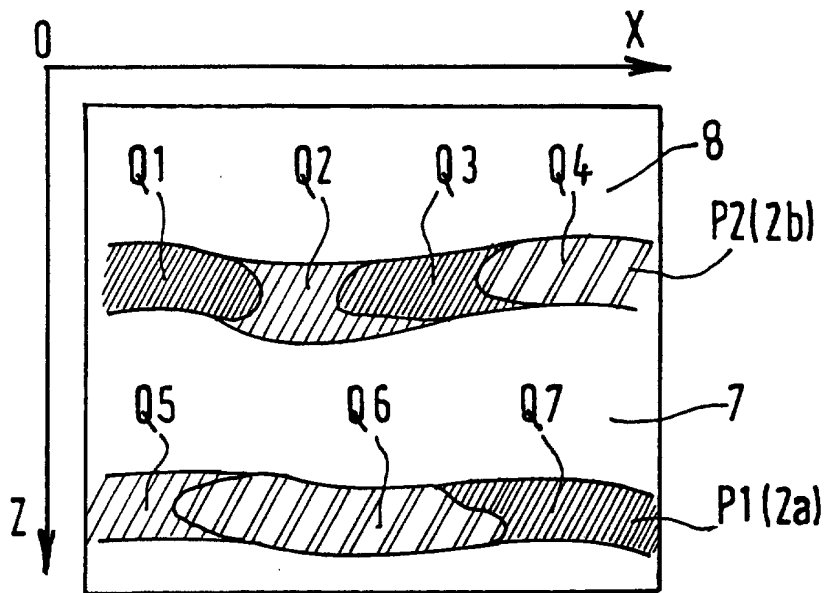

FIG. 3

专利名称(译)	用于显示具有移动部件的物体的超声波颜色编码图像序列的超声波图像处理方法和系统		
公开(公告)号	EP1158904B1	公开(公告)日	2004-07-21
申请号	EP2000991603	申请日	2000-12-13
[标]申请(专利权)人(译)	皇家飞利浦电子股份有限公司		
申请(专利权)人(译)	皇家飞利浦电子N.V.		
当前申请(专利权)人(译)	皇家飞利浦电子N.V.		
[标]发明人	BONNEFOUS ODILE		
发明人	BONNEFOUS, ODILE		
IPC分类号	A61B8/06 A61B8/08 G01S7/52 G01S15/89 G06T1/00 G06T7/20		
CPC分类号	A61B5/02007 A61B8/06 A61B8/13 A61B8/463 A61B8/488 G01S7/52071 G01S7/52074 G01S15/8979		
代理机构(译)	LOTTIN, CLAUDINE		
优先权	1999403309 1999-12-28 EP		
其他公开文献	EP1158904A1		
外部链接	Espacenet		

摘要(译)

本发明涉及一种超声波图像处理方法，其具有以下步骤：获取与介质中具有移动部件的物体相关的超声波信号；构造超声灰度2-D图像序列，表示物体的一段相对于垂直于灰度图像线（Z）的纵轴（X）的横截面；估计物体边界的位移和位移梯度，并且：对边界区域中的灰度级进行归一化，并根据位移梯度值对图像序列的边界区域的点进行颜色编码，以便提供物体运动部件位移变化的颜色编码信息。本发明还涉及一种用于执行具有彩色显示系统的所述方法的超声波检查成像系统。

