



US010424370B2

(12) **United States Patent**
Le Gallo-Bourdeau et al.

(10) **Patent No.:** **US 10,424,370 B2**
(45) **Date of Patent:** **Sep. 24, 2019**

(54) **SENSOR DEVICE WITH RESISTIVE MEMORY FOR SIGNAL COMPRESSION AND RECONSTRUCTION**

H04N 5/378 (2013.01); *A61B 5/0033* (2013.01); *G06K 9/40* (2013.01); *G06T 9/00* (2013.01); *G11C 2213/79* (2013.01); *H03M 1/12* (2013.01)

(71) Applicant: **International Business Machines Corporation**, Armonk, NY (US)

(58) **Field of Classification Search**
CPC ... H03M 1/12; G06K 9/40; G06T 9/00; A61B 5/0033

(72) Inventors: **Manuel Le Gallo-Bourdeau**, Zurich (CH); **Abu Sebastian**, Adliswil (CH); **Giovanni Cherubini**, Rueschlikon (CH)

USPC 341/126, 155; 382/232, 275, 299, 131
See application file for complete search history.

(73) Assignee: **International Business Machines Corporation**, Armonk, NY (US)

(56) **References Cited**

(*) Notice: Subject to any disclaimer, the term of this patent is extended or adjusted under 35 U.S.C. 154(b) by 0 days.

U.S. PATENT DOCUMENTS

8,749,422 B1 6/2014 Moore
8,982,260 B2 3/2015 Eshraghian et al.
(Continued)

(21) Appl. No.: **16/031,041**

OTHER PUBLICATIONS

(22) Filed: **Jul. 10, 2018**

Massoud, Y., et al., "A Memristor-Based Random Modulator for Compressive Sensing Systems", Conference Paper, May 2012, pp. 2245-2448.

(65) **Prior Publication Data**

US 2019/0122727 A1 Apr. 25, 2019

(Continued)

Related U.S. Application Data

Primary Examiner — Joseph J Lauture

(60) Provisional application No. 62/576,084, filed on Oct. 24, 2017.

(74) *Attorney, Agent, or Firm* — Scully, Scott, Murphy & Presser, P.C.; Daniel P. Morris, Esq.

(51) **Int. Cl.**
G11C 13/00 (2006.01)
G06F 17/16 (2006.01)
H04N 5/378 (2011.01)
G06T 9/00 (2006.01)
G06K 9/40 (2006.01)
H03M 1/12 (2006.01)
A61B 5/00 (2006.01)

(57) **ABSTRACT**

A sensor device comprising a computational memory and electronic circuitry. The sensor device is configured to receive an input signal, to compress the input signal into a compressed signal and to compute a reconstructed signal from the compressed signal. The electronic circuitry is configured to perform a reconstruction algorithm to compute the reconstructed signal. The computational memory is configured to compute the compressed signal and partial results of the reconstruction algorithm. A related method and a related design structure may be provided.

(52) **U.S. Cl.**
CPC *G11C 13/0004* (2013.01); *G06F 17/16* (2013.01); *G11C 13/004* (2013.01); *G11C 13/0064* (2013.01); *G11C 13/0069* (2013.01);

18 Claims, 5 Drawing Sheets

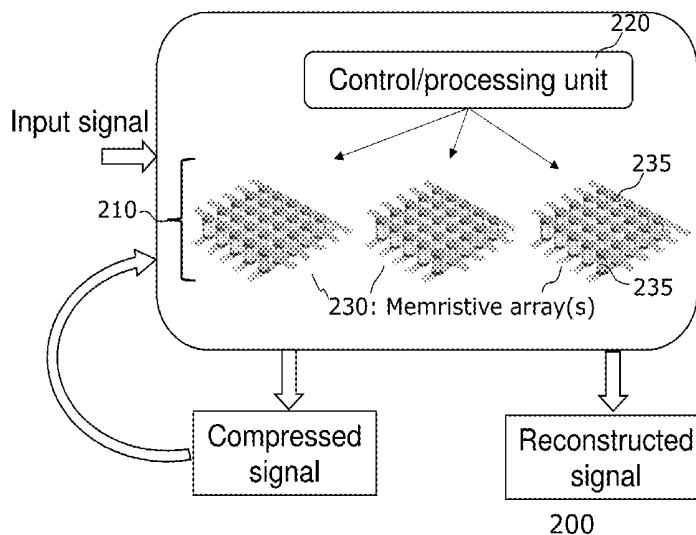

(56)

References Cited

U.S. PATENT DOCUMENTS

2006/0029279 A1* 2/2006 Donoho G06K 9/0057
382/232
2015/0372805 A1 12/2015 Yoon
2018/0046598 A1 2/2018 Le Gallo et al.
2018/0067720 A1 3/2018 Bekas et al.

OTHER PUBLICATIONS

Shukai, D., et al., "Analog memristive memory with applications in audio signal processing", Science China Information Sciences, Research Paper, Received Jan. 14, 2013, Accepted Feb. 19, 2013, pp. 1-15.

Liu S. et al., "Ultra-Fast Robust Compressive Sensing Based on Memristor Crossbars", Draft, Sep. 19, 2016, pp. 1-10.

Oike, Y., et al., "CMOS Image Sensor With Per-Column $\Sigma\Delta$ ADC and Programmable Compressed Sensing", IEEE Journal of Solid-State Circuits, Jan. 2013, pp. 318-328, vol. 48, No. 1.

Maechler, P., et al., "VLSI Design of Approximate Message Passing for Signal Restoration and Compressive Sensing", IEEE Journal on Emerging and Selected Topics in Circuits and Systems, Oct. 2012, 11 pages, vol. 2, No. 3.

Borghetti, J., et al., "Memristive' switches enable 'stateful' logic operations via material implication", Nature, Apr. 8, 2010, pp. 873-976, vol. 464.

Ievlev, A.V., et al., "Intermittency, quasiperiodicity and chaos in probe-induced ferroelectric domain switching", Nature Physics, Published online Nov. 17, 2013, Jan. 2014, pp. 59-66, vol. 10.

Di Ventra, M., et al., "The parallel approach", Nature Physics, Apr. 2013, pp. 200-202, vol. 9.

Hosseini, C., et al., "An optoelectronic framework enabled by low-dimensional phase-change films", Nature, Jul. 10, 2014, pp. 206-211, vol. 511.

Burr, G.W., et al., "Experimental demonstration and tolerancing of a large-scale neural network (165,000 synapses), using phase-change memory as the synaptic weight element", Proc. IEDM, Dec. 17, 2014, pp. 29.5.4-29.5-4.

Prezioso, M., et al., "Training and operation of an integrated neuromorphic network based on metal-oxide memristors", Nature, May 7, 2015, pp. 61-64, vol. 521.

Gupta, S., et al., "Deep Learning with Limited Numerical Precision", arXiv, Feb. 9, 2015, pp. 1-10.

Donoho, D., et al., "Message-passing algorithms for compressed sensing", PNAS, Sent for review Jul. 21, 2009, Nov. 10, 2009, pp. 18914-18919, vol. 106, No. 45.

Bayati, M., et al., "The Dynamics of Message Passing on Dense Graphs, with Applications to Compressed Sensing", IEEE Transactions on Information Theory, Feb. 2011, pp. 764-785, vol. 57, No. 2.

* cited by examiner

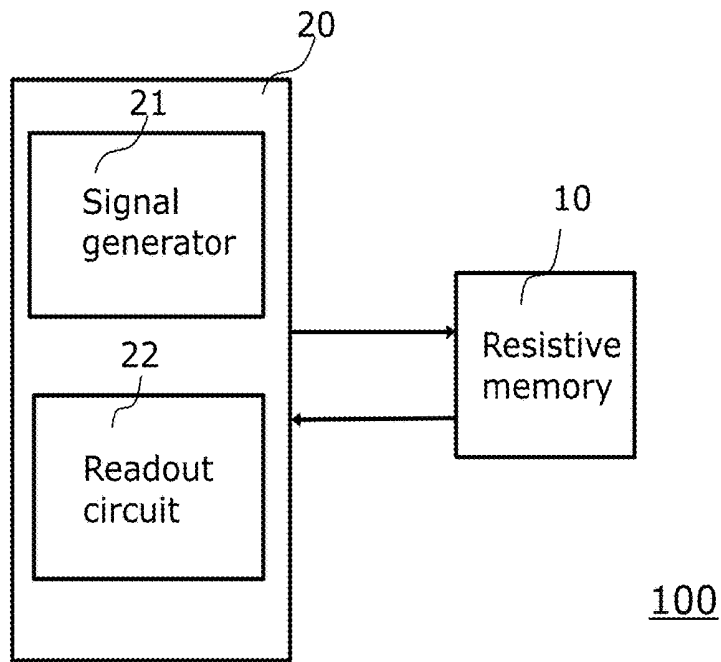

FIG. 1

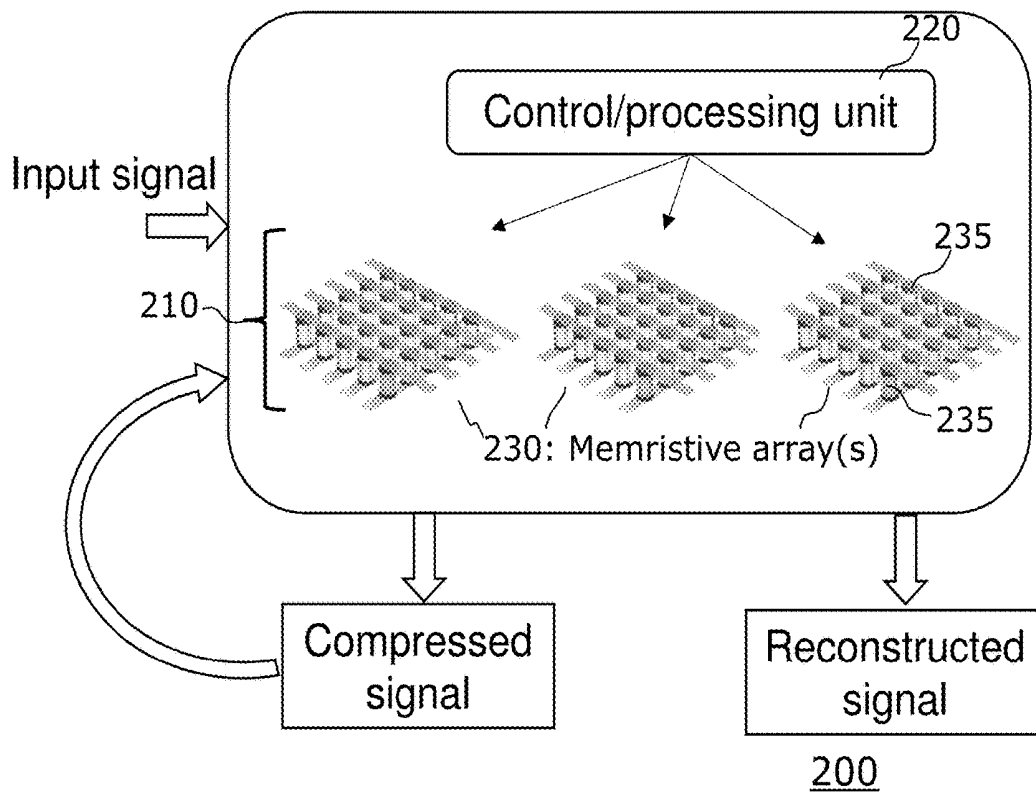
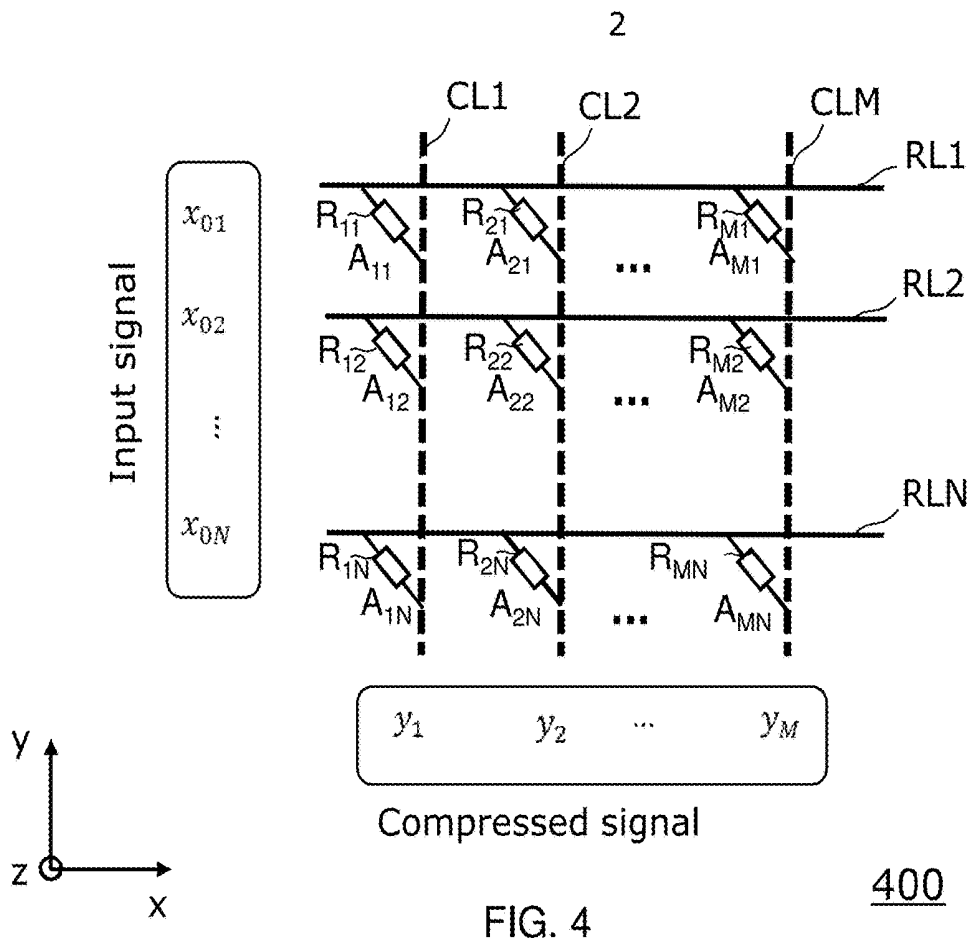
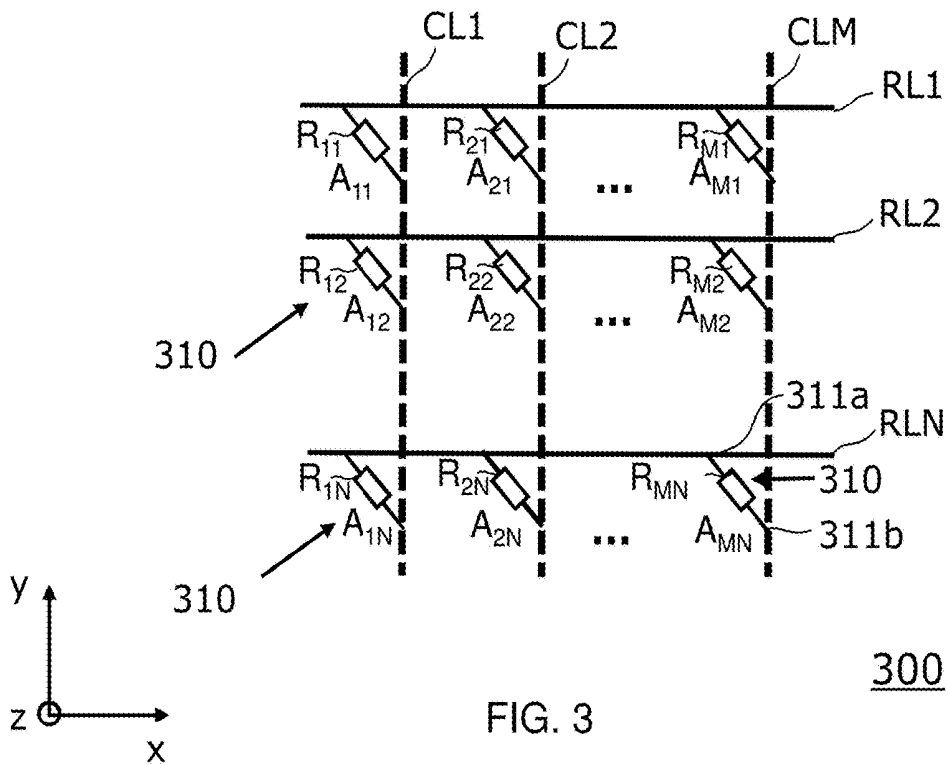

FIG. 2



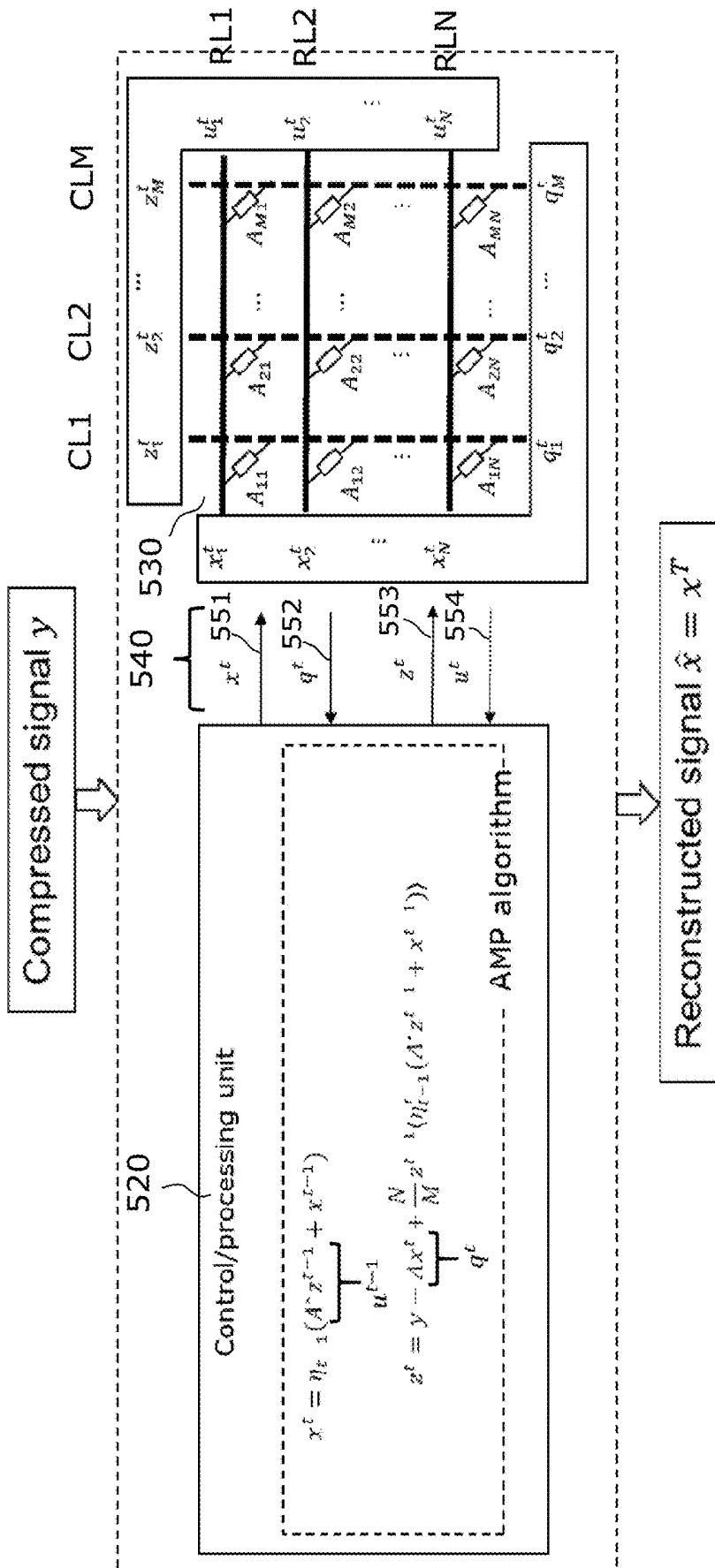

FIG. 5

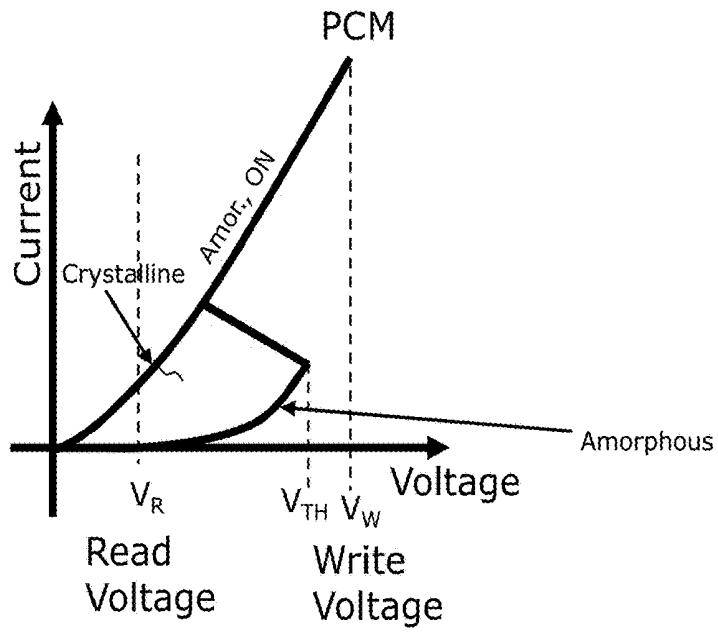

FIG. 6

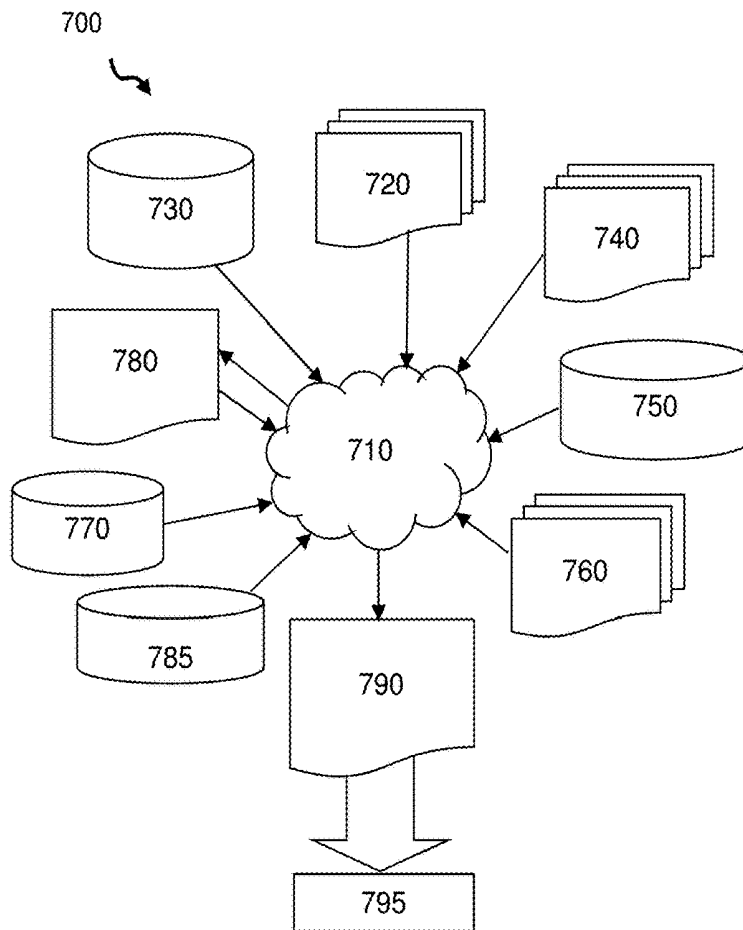
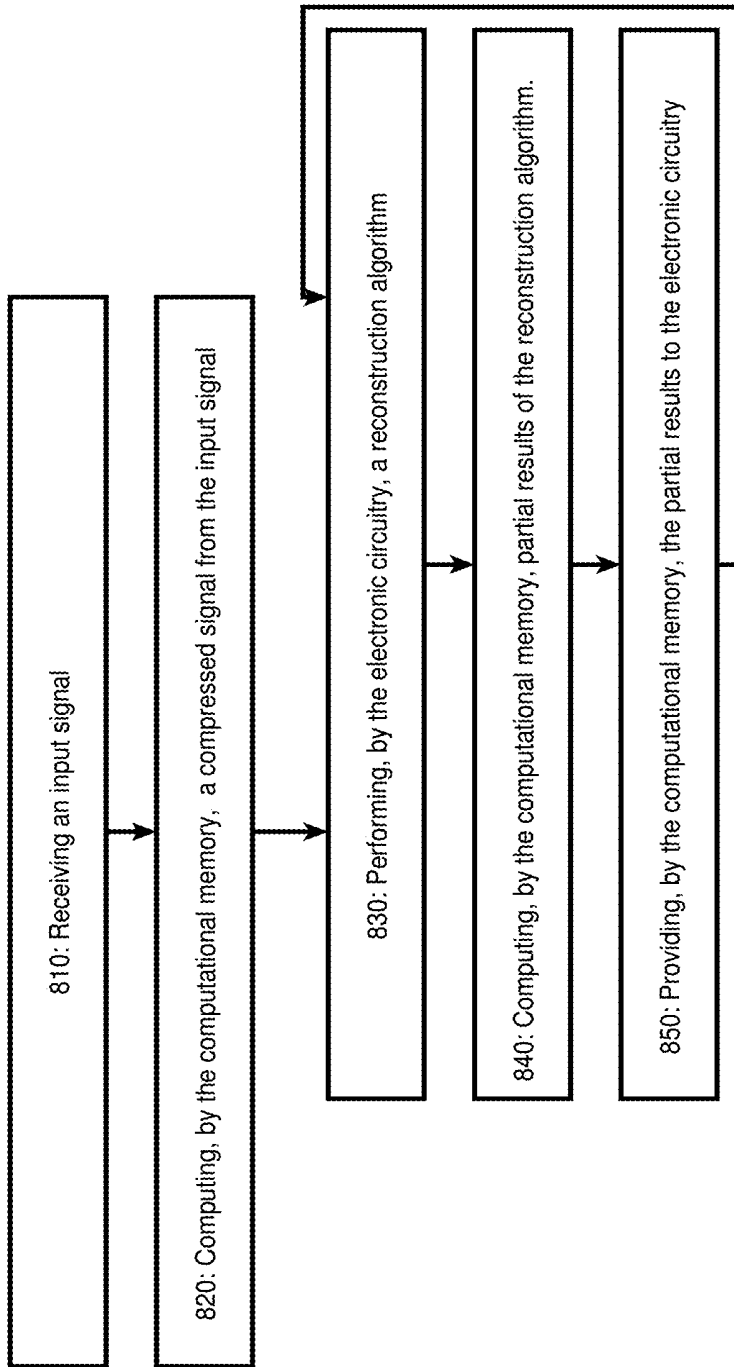

FIG. 7



800

FIG. 8

SENSOR DEVICE WITH RESISTIVE MEMORY FOR SIGNAL COMPRESSION AND RECONSTRUCTION

BACKGROUND

The basic idea of compressed sensing is to reconstruct a high-dimensional signal from a small number of measurements. The compressive measurements can be thought of as a linear mapping of a signal x_0 of length N to a measurement vector y of length $M < N$. This process can be modeled by a $M \times N$ measurement matrix A .

The compressed sensing reconstruction problem is to determine the signal x_0 from the measurements y when sampled as

$$y = Ax_0 + w;$$

wherein w represents the measurement noise.

Compressed sensing asserts that signals can be recovered from fewer samples than dictated by the Shannon-Nyquist theorem if they are sparse, that is, it allows to reconstruct a signal by finding a solution to an underdetermined linear system if the signal is sparse in some transform domain. If the signal x_0 is sparse in some transform domain, i.e. $x_0 = \Psi \xi$ where ξ is sparse, it can be shown that if Ψ is incoherent with A , then ξ can be recovered when $M < N$. Ψ represents the inverse transform matrix, for example an inverse Wavelet transform.

Compressed sensing can be used in various applications such as MRI, facial recognition, holography, audio restoration or in mobile phone camera sensors. In a camera sensor, the approach allows e.g. to significantly reduce the acquisition energy per image (or equivalently increase the image frame rate) by capturing only few measurements (e.g. 10%) instead of the whole image. However, this comes at the cost of complex reconstruction algorithms.

SUMMARY

According to a first aspect, the invention is embodied as a sensor device comprising a computational memory and electronic circuitry. The sensor device is configured to receive an input signal, to compress the input signal into a compressed signal and to compute a reconstructed signal from the compressed signal. The electronic circuitry is configured to perform a reconstruction algorithm to compute the reconstructed signal. The computational memory is configured to compute the compressed signal and partial results of the reconstruction algorithm.

According to an embodiment of another aspect of the invention, a method for signal compression and reconstruction is provided. The method is performed by a sensor device which comprises a computational memory and electronic circuitry. The method comprises steps of receiving, by the sensor device, an input signal and computing, by the computational memory, a compressed signal from the input signal. The method comprises a further step of performing, by the electronic circuitry, a reconstruction algorithm to compute a reconstructed signal from the compressed signal. Further steps include computing, by the computational memory, partial results of the reconstruction algorithm and providing, by the computational memory, the partial results to the electronic circuitry for a further processing of the reconstruction algorithm.

According to another aspect a design structure is provided. The design structure is tangibly embodied in a machine readable medium for designing, manufacturing, or

testing an integrated circuit. The design structure comprises a sensor device comprising a computational memory and electronic circuitry. The sensor device is configured to receive an input signal, to compress the input signal into a compressed signal and to compute a reconstructed signal from the compressed signal. The electronic circuitry is configured to perform a reconstruction algorithm to compute the reconstructed signal. The computational memory is configured to compute the compressed signal and partial results of the reconstruction algorithm.

Embodiments of the invention will be described in more detail below, by way of illustrative and non-limiting examples, with reference to the accompanying drawings.

BRIEF DESCRIPTION OF THE SEVERAL VIEWS OF THE DRAWINGS

FIG. 1 is a simplified schematic block diagram of a sensor device according to embodiments of the invention;

FIG. 2 illustrates schematically the operation of a sensor device according to an embodiment of the invention;

FIG. 3 illustrates schematically a memristive array of a computational memory according to an embodiment of the invention that has been programmed as a measurement matrix $M \times N$;

FIG. 4 illustrates the computation of a compressed signal from an input signal with a memristive array according to an embodiment of the invention;

FIG. 5 illustrates an example embodiment of a computation of a reconstructed signal from the compressed signal by means of the sensor device;

FIG. 6 is a schematic illustration of the current/voltage characteristics of the material components of a phase change memory cell;

FIG. 7 shows a block diagram of an example design flow; and

FIG. 8 shows a flowchart of method steps of a method for signal compression and reconstruction.

DETAILED DESCRIPTION

In reference to FIGS. 1-8, some general aspects and terms of embodiments of the invention are described.

According to embodiments of the invention, a resistive memory element may be defined as a memory element whose electrical resistance can be changed by applying an electrical programming signal to the resistive memory element. The electrical programming signal may be e.g. a current flowing through the resistive memory element, or an electrical voltage applied to the resistive memory element. The current and/or voltage may be e.g. applied to the resistive memory element in the form of pulses. As a result, the electrical resistance of a resistive memory element depends on the history of current that had previously flown through the memory element and/or the history of the electric signal that had been applied to the resistive memory element.

Resistive memory elements are based on a physical phenomenon occurring in a material that changes its resistance under action of a current or electric field. The change is usually non-volatile and reversible. Several classes of resistive memory elements are known, ranging from metal oxides to chalcogenides. Typical resistive memory elements are metal/insulator/metal structures where the metallic components serve as the electrodes and the insulator is a resistive switching material, e.g. a chalcogenide. These resistive

memory elements exhibit good performance in terms of power consumption, integration density potential, retention, and endurance.

Memcomputing is a non-Von Neumann approach being researched. An element in this computing paradigm is a computational memory. The computational memory may comprise high-density, low-power, variable state, programmable and non-volatile memory devices.

A computational primitive is a matrix-vector multiplication. This primitive is of particular interest as it forms the basis of several linear algebraic operations and it is one of the most commonly used mathematical operations in science and engineering. A matrix is usually represented by a two-dimensional array of matrix elements and a vector by a one-dimensional array of vector elements. A matrix may be considered as array of vectors. Hence a matrix-vector multiplication can be generalized to a matrix-matrix multiplication and to a vector-vector multiplication.

According to embodiments of the invention a computational memory may be used to perform certain low-level computational tasks of sensor devices, in particular matrix vector multiplications for signal compression and reconstruction.

Such computational memory may, for example, be implemented as an interconnected array of nanoscale resistive memory devices, or memristor arrays. These arrays may be made compact due to the density of the memristors within the array, and the overall energy efficiency of the devices may be better than that achieved by systems using von Neumann architectures to perform similar computations.

FIG. 1 is a simplified schematic block diagram of a sensor device **100** according to embodiments of the invention. The sensor device **100** comprises electronic circuitry **20** and a resistive memory **10** having a plurality of resistive memory elements. The resistive memory **10** serves as computational memory and may accordingly also be denoted as computational memory **10**. The electronic circuitry **20** encompasses a signal generator **21** and a readout circuit **22**. The signal generator **21** is configured to apply electrical programming signals to the resistive memory elements of the resistive memory **10**. The signal generator **21** comprises circuitry for programming the resistive memory cells during data write or programming operations such that a multiplication of a matrix with a vector can be performed. During these write operations, the signal generator **21** can address individual memory cells by applying appropriate control signals to an array of row lines and column lines in the resistive memory **10**. The row lines and column lines may also be denoted as word and bit lines.

The signal generator **21** may be configured to receive a matrix **A**, in particular a measurement matrix, as input and to apply programming signals to the memory elements to program conductance values of the resistive memory elements as a measurement matrix for subsequent matrix-vector multiplications. The conductance values represent measurement matrix values of the measurement matrix that shall be multiplied with the respective vectors.

In addition, the device **100** comprises a readout circuit **22** configured to read out resistance values of the resistive memory elements during data read operations. More particularly, the sensor device **100** is configured to apply read out voltages to the rows and/or columns of memristive arrays of the resistive memory **10**. The read out voltages represent vector elements of the vector that shall be multiplied with the matrix. The device is further configured to read out current values of columns and/or rows of the

memristive array. The current values represent result values of vector elements of a result vector of the respective matrix-vector multiplication.

The resistive memory **10** may be generally any kind of resistive memory as described above. In particular it may be a phase change memory (PCM) or a resistive random access memory (RRAM). In the following it assumed that the resistive memory **10** is embodied as PCM. Accordingly the resistive memory **10** may comprise a plurality of PCM cells as resistive memory elements. The PCM cells of memory **10** may comprise $s=2$ or $s>2$ programmable resistance states, the latter providing multilevel operation. The s programmable resistance-states correspond to different relative proportions of the amorphous and crystalline phases within the PCM material of the cell. These states may include a high-resistance, fully-amorphous RESET state, a low-resistance, fully-crystalline SET state, and a number of intermediate states corresponding to increasing size of the crystalline phase within the otherwise amorphous PCM material. The s programmable cell-states are typically defined in terms of predetermined reference values, or ranges of values, of the resistance metric used for read detection by the readout circuit **22**.

To perform a matrix-vector multiplication, the PCM cells are programmed according to embodiments in a kind of write operation. More particularly, the signal generator **21** applies a voltage to the cell via the column lines and row lines such that the resulting programming signal sets the cell to a state (conductance value) that represents a matrix element of the measurement matrix that shall be multiplied with the respective vector in subsequent operations. In a read operation, (lower) read voltages are applied to the row and/or column lines. Then the resulting column current values row and/or row current values are read/measured to obtain the result vector.

FIG. 2 illustrates schematically the operation of a sensor device **200** according to an embodiment of the invention. The sensor device **200** comprises a control/processing unit **220** which includes electronic circuitry and a computational memory **210** embodied as resistive memory **210**. The resistive memory **210** comprises a plurality of memristive arrays **230** comprising a plurality of resistive memory elements **235**. The resistive memory elements **235** are arranged in a crossbar topology.

In operation the sensor device **200** receives an input signal, in particular a measurement signal from a sensor measurement, and compresses the input signal into a compressed signal. The compression is performed by means of the computational memory **210**. More particularly, the computational memory **210** compresses the input signal by performing a matrix-vector multiplication of the input signal with a measurement matrix that has been programmed to one of the memristive arrays **230**.

Furthermore, the sensor device **200** computes a reconstructed signal from the compressed signal. More particularly, the electronic circuitry of the control/processing unit **220** performs a reconstruction algorithm, in particular an approximate message passing algorithm. During the execution of the reconstruction algorithm, the computational memory **210** computes partial results of the reconstruction algorithm and provides these partial results back to the control/processing unit **220**. More particularly, the computational memory **210** computes the partial results of the reconstruction algorithm by performing matrix-vector multiplications with the measurement matrix. The partial results may establish intermediate state variables of the reconstruction algorithm. The control/processing unit **220** uses then

these partial results for the further processing of the reconstruction algorithm. After a sufficient number of T iterations of the reconstruction algorithm, the control/processing unit 220 may output the final reconstructed signal.

Hence such an embodied sensor provides the advantage that the compression as well as the reconstruction is performed on the sensor device itself. This is in contrast to conventional sensor devices that often require an off-device implementation of the reconstruction algorithm.

This is in particular useful for Internet of Things (IoT systems). The processing of the compressed signal and the partial results of the reconstruction algorithm may be performed by the computational memory with very low power. This allows energy-efficient signal acquisition while at the same time avoiding to send the compressed signal e.g. to the cloud for reconstruction.

Accordingly, compared with compression and reconstruction techniques based on the conventional Von-Neumann approach, sensor devices according to embodiments of the invention may bring significant power and/or speed advantages.

FIG. 3 illustrates schematically a memristive array 300 of a computational memory according to an embodiment of the invention that has been programmed as a measurement matrix MxN.

The memristive array 300 comprises a plurality of row lines RL1, RL2, . . . , RLN and a plurality of column lines CL1, CL2, . . . , CLM. The row lines are arranged above the column lines which are indicated by dotted lines. More particularly, the row lines extend in a first x-y-plane and the column lines extend in a second x-y plane, wherein the first x-y plane is arranged in the vertical z-direction above the second x-y-plane.

The row lines and the column lines are connected to each other via vertical junctions 310. The junctions 310 extend in the vertical z-direction between upper cross points 311a of the row lines and lower cross points 311b of the column lines.

Each junction 310 comprises a serial arrangement of a resistive memory element R_{mn} and a transistor. For ease of illustration, the transistors are not shown in FIG. 3.

In order to program the measurement matrix A, the signal generator 21 (see FIG. 1) applies programming signals, in particular current pulses, to the resistive memory elements R_{mn} and thereby programs the conductance values for subsequent matrix-vector multiplications with the measurement matrix A. More particularly, the conductance values of the resistive memory elements R_{mn} represent matrix values A_{mn} of the measurement matrix A. As an example, the conductance of the resistive memory element R₁₁ is programmed to the matrix value A₁₁, the conductance of the resistive memory element R₁₂ is programmed to the matrix value A₁₂, or more generally the conductance of the resistive memory R_{mn} is programmed to a corresponding matrix value A_{mn}.

According to embodiments, the MxN measurement matrix A may be programmed as device conductance values in one or multiple memristive arrays. In particular, according to embodiments the transpose A* of the measurement matrix A can be programmed in a separate memristive array.

One possible method to program the conductance values is using an iterative program-and-verify procedure. According to embodiments, the elements A_{mn} of the measurement matrix A can be programmed on multiple devices/arrays, and the average conductance of the multiple devices/arrays may be used to represent one element of the measurement matrix A.

According to embodiments, A may contain negative elements and those negative elements may be coded separately from the positive ones together with a subtraction circuit.

FIG. 4 illustrates a compression of an input signal x₀ according to an embodiment of the invention. The compression is performed by means of a matrix-vector multiplication with the measurement matrix A.

The matrix-vector multiplication uses Ohm's law and Kirchhoff's law in a memristive array 400 which corresponds to the memristive array 300 as described with reference to FIG. 3.

The input signal x₀ comprises as vector elements the elements x₀₁, x₀₂, . . . , x_{0N}. The readout circuit 22 (see FIG. 1) applies read voltages to the row lines. More particularly, the readout circuit 22 applies a read voltage x₀₁ to the row line RL1, a read voltage x₀₂ to the row line RL2 or generally a read voltage x_{0n} to the row line RLn. Hence the read voltages represent vector values of the vector of the matrix-vector multiplication.

Furthermore, the readout circuit 22 reads out current values of the column lines CLm. As an example, the readout circuit 22 reads out a current value y₁ from the column line CL1 which is the sum of N multiplications, namely

$$y_1 = A_{11}x_{01} + A_{12}x_{02} + \dots + A_{1N}x_{0N}$$

Accordingly, the readout circuit 22 reads out a current value y₂ from the column line CL2 and generally a current value y_m from the column line CLm. The current values represent the result values of the vector elements of the product vector y. The product vector y forms the compressed signal of the input signal x₀.

Hence the input signal x₀ is compressed by applying it as voltage values at the input of the corresponding memristive array(s). The compressed signal y is obtained as the current signal at the output of the corresponding memristive array (s). The memristive crossbar array(s) essentially perform the operation

$$y = Ax_0$$

FIG. 5 illustrates an example embodiment of the computation of a reconstructed signal $\hat{x} = x^T$ from the compressed signal y by means of a sensor device 500. The compressed signal y may be computed e.g. as illustrated with reference to FIG. 4. The computation of the reconstructed signal $\hat{x} = x^T$ is performed by executing a reconstruction algorithm. According to the example embodiment of FIG. 5, the reconstruction algorithm is an approximate message passing algorithm.

In general, an approximate message passing (AMP) algorithm solves the problem of reconstructing a vector x₀ ∈ ℝ^N from a vector of linear observations y ∈ ℝ^M.

For example, a vector x₀ ∈ ℝ^N may be reconstructed from a vector of linear observations y ∈ ℝ^M, such that y = Ax₀ + w. A ∈ ℝ^{MxN} is the known measurement matrix and w ∈ ℝ^M is a noise vector w ~ N(0, σ²). The approximate message passing algorithm is an approximation to the following sum-product message passing algorithm. For all n, n' ∈ [N] = {1, 2, . . . , N} and m, m' ∈ [M] = {1, 2, . . . , M} start at time t=0 with messages x_{n→m}⁰ = 0 and proceed by

$$z_{m \rightarrow n}^t = y_m - \sum_{n' \neq n} A_{m n'} x_{n' \rightarrow m}^t \text{ and}$$

-continued

$$x_{n \rightarrow m}^{t+1} = \eta_t \left(\sum_{m' \neq m} A_{m'n} z_{m' \rightarrow n}^t \right),$$

where $z_{m \rightarrow n}^t$ represents the message passed from a function node g_m to a variable node x_{0n} , $x_{n \rightarrow m}^t$ represents the message passed from a variable node to a function node and $\eta_t(\cdot)$ is a function.

An approximate message passing algorithm/technique may approximate a sum-product message passing technique in the large system limit, allowing updates of only $O(N)$ variables instead of $O(MN)$.

For example, a first order approximate message passing technique for reconstructing x_0 given A and y (Donoho et al., PNAS, 2009) may be represented as

$$z^t = y - Ax^t + \frac{N}{M} z^{t-1} \langle \eta'_{t-1}(A * z^{t-1} + x^{t-1}) \rangle;$$

$$x^{t+1} = \eta_t(A * z^t + x^t);$$

wherein A^* is the transpose of A , $\eta_t(\cdot)$ is a function, $\eta'_t(\cdot)$ its derivative, $\langle \cdot \rangle$ denotes the mean and $x^0=0$. The final value of x^t may provide the estimate of x_0 .

The AMP algorithm/technique may be equivalently formulated as an iterative thresholding process, which may provide the reconstruction power of other approaches, when sparsity of the solution may be assumed, at a much lower complexity. The AMP algorithm has a relatively simple formulation and requires only multiplications and additions.

For example, the AMP technique may be used to reconstruct a random vector $x_0 \in \mathbb{R}^N$, $x_{0n} \sim N(0, \rho^2)$, $\forall n$, from a vector of linear observations $y \in \mathbb{R}^M$, where $y = Ax_0 + w$, and $A \in \mathbb{R}^{M \times N}$ is a known measurement matrix. If a linear function $\eta_t(\cdot) = \lambda_t \times (\cdot)$ is chosen, the AMP technique/algorithm may be represented as

$$x^{t+1} = \lambda_t(A * z^t + x^t);$$

$$z^t = y - Ax^t + \frac{N}{M} z^{t-1} \lambda_{t-1};$$

wherein A^* is the transpose of A , $x^0=0$ and

$$\lambda_t = \frac{1}{1 + \tau_t^2};$$

$$\tau_{t+1}^2 = \sigma^2 + \frac{N}{M} \frac{\tau_t^2}{\tau_t^2 + 1};$$

with

$$\tau_0^2 = \sigma^2 + \frac{N}{M} \rho^2.$$

Here, z^t and x^t are the outgoing means of the random variables associated with the g and x_0 nodes, respectively, and λ_t is a state variable. If

$$A_{mn} \sim N\left(0, \frac{1}{M}\right)$$

(iid normalized Gaussian matrix), the convergence behavior of this algorithm may be given by

$$\lim_{N \rightarrow \infty} \frac{1}{N} \|x^t - x_0\|^2 = (\tau_t^2 - \sigma^2) \frac{M}{N}.$$

The sensor device **500** comprises a control/processing unit **520** and a memristive array **530**. The control/processing unit **520** and the memristive array **530** are coupled via a communication link **540** and may exchange data, in particular state variables and partial results of the reconstruction algorithm, via the communication link **540**.

The control/processing unit **520** may control the operation and processing performed by the sensor device **500** and may typically be implemented by electronic circuitry including digital combinational logic. Memristive array **530** performs a portion of the computations that implement the AMP technique/algorithm, and may communicate with control/processing unit **520** using communication link **540**, in particular to provide partial results of the reconstruction algorithm to the control/processing unit **520**.

To reconstruct the compressed signal y , the AMP algorithm is run in the control/processing unit **520** for T iterations. The control/processing unit **520** provides x^t at a step **551** to the memristive array **530**. x^t may be considered as a state variable of the AMP algorithm. More particularly, it provides x^t to the row lines RL1, RL2, . . . , RLN of the memristive array **530**. Then the memristive array **530** performs at a step **552** a matrix-vector multiplication of the measurement matrix A and x^t and provides as partial result

$$q^t = Ax^t$$

to the control/processing unit **520**. More particularly, the memristive array **530** provides $q^t = Ax^t$ at the column lines CL1, CL2, . . . , CLM of the memristive array **530**.

At a step **553**, the control/processing unit **520** computes

$$z^t = y - q^t + \frac{N}{M} z^{t-1} \langle \eta'_{t-1}(A * z^{t-1} + x^{t-1}) \rangle$$

by utilizing the partial result

$$q^t = Ax^t$$

and provides z^t to the memristive array **510**. More particularly, it provides z^t as input to the column lines CL1, CL2, . . . , CLM of the memristive array **530**.

At a step **554**, the memristive array **530** performs a matrix-vector multiplication of the transpose A^* of the measurement matrix and z^t and provides as partial result

$$u^t = A^* z^t$$

to the control/processing unit **520**. More particularly, the memristive array **510** provides $u^t = A^* z^t$ at the row lines RL1, RL2, . . . , RLN.

Finally, the control/processing unit **520** computes

$$x^{t+1} = \eta_t(u^t + x^t)$$

by utilizing the partial result

$$u^t = A^* z^t$$

and provides x^{t+1} to the memristive array **510** for the next AMP iteration.

Hence the computation of q^t and u^t is done using the one single memristive array **530**, assuming appropriate read/write circuitry to apply voltages x^t and z^t , and measure currents q^t and u^t .

According to other embodiments, two separate memristive arrays may be provided, one for the computation of q^t and one for the computation of u^t .

After T iterations, the reconstructed signal $\hat{x}=x^T$ is obtained.

According to embodiments, the reconstruction algorithm may comprise an integrated de-noising functionality. A general methodology for compressive imaging with AMP is introduced in [Metzler et al., From Denoising to Compressed Sensing, arXiv, 2014]. The algorithm may be written as

$$\begin{aligned} z^t &= y - Ax^t + z^{t-1} \text{div}D_{v_t^2}(A * z^{t-1}) \\ x^{t+1} &= D_{v_t^2}(A * z^t) \\ \text{div}D(x) &= \sum_{i=1}^N \frac{\partial D(x)_i}{\partial x_i} \end{aligned}$$

In this representation of the reconstruction algorithm $D(x)$ denotes the denoiser and v_t^2 is an estimate of the variance of the noisy signal which is input to the denoiser.

Using a denoiser within AMP improves the signal reconstruction quality in the presence of measurement noise and also in the presence of the computational errors from the memristive array. According to embodiments, a denoiser may be designed which is specifically aimed at removing the errors due to computation in the memristive array in the reconstructed signal. Examples of denoisers are BM3D and wavelet denoisers with soft-thresholding. A wavelet denoiser transforms the signal into a wavelet basis, thresholds the coefficients, and then inverts the transform. An example is a Haar Wavelet transform and a soft-threshold function, defined as $D_{v_t^2}(x)=W^{-1} \eta_t(Wx)$, where:

$$\eta_t(x) = \begin{cases} x - \lambda v_t, & x \geq \lambda v_t \\ x + \lambda v_t, & x \leq -\lambda v_t \\ 0, & \text{otherwise} \end{cases}$$

The term $\text{div}D_{v_t^2}(A * z^{t-1} + x^{t-1})$ can be calculated explicitly and given by $\|\eta_{t-1}(W(A * z^{t-1} + x^{t-1}))\|_{\lambda_0}$ (number of non-zero elements of thresholded sparsified estimate) where W denotes the wavelet transform.

According to another embodiment, a BM3D denoiser may be used. Block matching 3D collaborative filtering can be considered as a combination of non-local means (averaging neighboring weighted pixels) and wavelet thresholding. The term $\text{div}D_{v_t^2}(A * z^{t-1} + x^{t-1})$ cannot be calculated explicitly and may be estimated using a Monte-Carlo procedure as described e.g. in [Metzler et al., From Denoising to Compressed Sensing, arXiv, 2014]. BM3D may perform better on images than Wavelet thresholding because images are not exactly sparse in the Wavelet domain.

According to another embodiment, the sensor device is configured to perform a block-based compression and reconstruction. To compress and reconstruct e.g. a 128x128

image, the size of the vector x_0 (pixel intensities of the image) is $N=16384$. For such a large value of N it may require a very large number of devices (at least 10M) to code a Gaussian $M \times N$ matrix in the memristive array. According to one embodiment, a $M_s \times N_s$ Gaussian measurement matrix H may be used, in particular a much smaller measurement matrix, and consecutive measurements on pixel blocks may be performed using the same measurement matrix H. According to an embodiment, for example 16x16 pixels blocks may be used, and thus $N_s=256$. To ensure convergence of the AMP algorithm, a strategy according to an embodiment is to do a (fixed) random permutation P of the pixel intensities before doing the measurements. According to such an embodiment, each iteration of the AMP algorithm will require one permutation and one inverse permutation. More particularly, the matrix A may be given by

A

A*

wherein

$$\text{Blockdiag}(H) = \begin{bmatrix} H & \dots & 0 \\ \vdots & \ddots & \vdots \end{bmatrix}$$

FIG. 6 is a schematic illustration of the current/voltage (and hence resistance) characteristics of the material components of a PCM cell. The solid lines indicate variation of current with voltage for the PCM material, starting from the fully-crystalline SET state (upper curve) and also the fully-amorphous RESET state (lower curve). These two curves reflect the large (typically 3 orders of magnitude) variation in resistivity between the crystalline and amorphous phases. The amorphous phase exhibits a non-linear characteristic with a threshold switching phenomenon that is field induced. At a certain threshold voltage V_{TH} , this phase switches to a very low "ON-state" resistance corresponding to that of the crystalline PCM material. The cell programming (write) voltage is selected to be above this threshold voltage as indicated.

FIG. 7 shows a block diagram of an example design flow **700** used for example, in semiconductor IC logic design, simulation, test, layout, and manufacture. Design flow **700** includes processes, machines and/or mechanisms for processing design structures or devices to generate logically or otherwise functionally equivalent representations of the design structures and/or devices described above and shown e.g. in FIGS. **1** to **5**. The design structures processed and/or generated by design flow **700** may be encoded on machine-readable transmission or storage media to include data and/or instructions that when executed or otherwise processed on a data processing system generate a logically, structurally, mechanically, or otherwise functionally equivalent representation of hardware components, circuits, devices, or systems. Machines include, but are not limited to, any machine used in an IC design process, such as designing, manufacturing, or simulating a circuit, component, device, or system. For example, machines may include: lithography machines, machines and/or equipment for generating masks (e.g. e-beam writers), computers or equipment for simulating design structures, any apparatus used in the manufacturing or test process, or any machines for programming functionally equivalent representations of the design structures into any medium (e.g. a machine for programming a programmable gate array).

Design flow **700** may vary depending on the type of representation being designed. For example, a design flow **700** for building an application specific IC (ASIC) may differ from a design flow **700** for designing a standard component or from a design flow **700** for instantiating the design into a programmable array, for example a programmable gate array (PGA) or a field programmable gate array (FPGA) offered by Altera® Inc. or Xilinx® Inc.

FIG. 7 illustrates multiple such design structures including an input design structure **720** that is, for example, processed by a design process **710**. Design structure **720** may be a logical simulation design structure generated and processed by design process **710** to produce a logically equivalent functional representation of a hardware device. Design structure **720** may also or alternatively comprise data and/or program instructions that when processed by design process **710**, generate a functional representation of the physical structure of a hardware device. Whether representing functional and/or structural design features, design structure **720** may be generated using electronic computer-aided design (ECAD) such as implemented by a core developer/designer. When encoded on a machine-readable data transmission, gate array, or storage medium, design structure **720** may be accessed and processed by one or more hardware and/or software modules within design process **710** to simulate or otherwise functionally represent an electronic component, circuit, electronic or logic module, apparatus, device, or system such as those shown in FIGS. 1 to 5. As such, design structure **720** may comprise files or other data structures including human and/or machine-readable source code, compiled structures, and computer-executable code structures that when processed by a design or simulation data processing system, functionally simulate or otherwise represent circuits or other levels of hardware logic design. Such data structures may include hardware-description language (HDL) design entities or other data structures conforming to and/or compatible with lower-level HDL design languages such as Verilog and VHDL, and/or higher level design languages such as C or C++.

Design process **710**, for example, employs and incorporates hardware and/or software modules for synthesizing, translating, or otherwise processing a design/simulation functional equivalent of the components, circuits, devices, or logic structures shown in FIGS. 1-5 to generate a Netlist **780** which may contain design structures such as design structure **720**. Netlist **780** may comprise, for example, compiled or otherwise processed data structures representing a list of wires, discrete components, logic gates, control circuits, I/O devices, models, etc. that describes the connections to other elements and circuits in an integrated circuit design. Netlist **780** may be synthesized using an iterative process in which netlist **780** is resynthesized one or more times depending on design specifications and parameters for the device. As with other design structure types described herein, netlist **780** may be recorded on a machine-readable data storage medium or programmed into a programmable gate array. The medium may be a non-volatile storage medium such as a magnetic or optical disk drive, a programmable gate array, a compact flash, or other flash memory. Additionally, or in the alternative, the medium may be a system or cache memory, buffer space, or electrically or optically conductive devices and materials on which data packets may be transmitted and intermediately stored via the Internet, or other networking suitable means.

Design process **710** may include hardware and software modules for processing a variety of input data structure types including Netlist **780**. Such data structure types may

reside, for example, within library elements **730** and include a set of commonly used elements, circuits, and devices, including models, layouts, and symbolic representations, for a given manufacturing technology (e.g., different technology nodes, 32 nm, 45 nm, 90 nm, etc.). The data structure types may further include design specifications **740**, characterization data **750**, verification data **760**, design rules **770**, and test data files **785** which may include input test patterns, output test results, and other testing information. Design process **710** may further include, for example, standard mechanical design processes such as stress analysis, thermal analysis, mechanical event simulation, process simulation for operations such as casting, molding, and die press forming, etc. One of ordinary skill in the art of mechanical design can appreciate the extent of possible mechanical design tools and applications used in design process **710** without deviating from the scope and spirit of the invention. Design process **710** may also include modules for performing standard circuit design processes such as timing analysis, verification, design rule checking, place and route operations, etc.

Design process **710** employs and incorporates logic and physical design tools such as HDL compilers and simulation model build tools to process design structure **720** together with some or all of the depicted supporting data structures along with any additional mechanical design or data (if applicable), to generate a second design structure **770**. Design structure **790** resides on a storage medium or programmable gate array in a data format used for the exchange of data of mechanical devices and structures (e.g. information stored in a IGES, DXF, Parasolid XT, JT, DRG, or any other suitable format for storing or rendering such mechanical design structures). Similar to design structure **720**, design structure **790**, for example, comprises one or more files, data structures, or other computer-encoded data or instructions that reside on transmission or data storage media and that when processed by an ECAD system generate a logically or otherwise functionally equivalent form of one or more of the embodiments of the invention shown in FIGS. 1 to 5. In one embodiment, design structure **790** may comprise a compiled, executable HDL simulation model that functionally simulates the devices shown in FIGS. 1-5.

Design structure **790** may also employ a data format used for the exchange of layout data of integrated circuits and/or symbolic data format (e.g. information stored in a GDSII (GDS2), GL1, OASIS, map files, or any other suitable format for storing such design data structures). Design structure **790** may comprise information such as, for example, symbolic data, map files, test data files, design content files, manufacturing data, layout parameters, wires, levels of metal, vias, shapes, data for routing through the manufacturing line, and any other data required by a manufacturer or other designer/developer to produce a device or structure as described above and shown in FIGS. 1-5. Design structure **790** may then proceed to a stage **795** where, for example, design structure **790**: proceeds to tape-out, is released to manufacturing, is released to a mask house, is sent to another design house, is sent back to the customer, etc.

FIG. 8 shows a flowchart of method steps of a method **800** for signal compression and reconstruction. The sensor device comprises a computational memory and electronic circuitry and may be embodied as described above with reference to FIGS. 1 to 5.

At a step **810**, the sensor device receives an input signal, e.g. a measurement signal measured by the sensor device.

At a step **820**, the computational memory computes a compressed signal from the input signal.

At a step **830**, the electronic circuitry performs a reconstruction algorithm to compute a reconstructed signal from the compressed signal.

At a step **840**, the computational memory computes partial results of the reconstruction algorithm.

At a step **850**, the computational memory provides the partial results to the electronic circuitry which may use them for the further execution of the reconstruction algorithm.

The steps **830**, **840** and **850** may be repeated in an iterative manner.

The descriptions of the various embodiments of the present invention have been presented for purposes of illustration, but are not intended to be exhaustive or limited to the embodiments disclosed. Many modifications and variations will be apparent to those of ordinary skill in the art without departing from the scope and spirit of the described embodiments. The terminology used herein was chosen to best explain the principles of the embodiments, the practical application or technical improvement over technologies found in the marketplace, or to enable others of ordinary skill in the art to understand the embodiments disclosed herein.

In general, modifications described for one embodiment may be applied to another embodiment as appropriate.

What is claimed is:

1. A sensor device comprising a computational memory; and electronic circuitry; the sensor device being configured to receive an input signal; compress the input signal into a compressed signal; and compute a reconstructed signal from the compressed signal; wherein the electronic circuitry is configured to perform a reconstruction algorithm to compute the reconstructed signal; and the computational memory is configured to compute the compressed signal and partial results of the reconstruction algorithm, wherein the computational memory comprises at least one memristive array comprising a plurality of resistive memory elements, the resistive memory elements being arranged in a crossbar topology.
2. A sensor device according to claim 1, wherein the electronic circuitry is configured to apply programming signals to the resistive memory elements to program conductance values as a measurement matrix; and the computational memory is configured to compress the input signal by performing a matrix-vector multiplication of the input signal with the measurement matrix; and compute the partial results of the reconstruction algorithm by performing matrix-vector multiplications with the measurement matrix.
3. A sensor device according to claim 2, wherein the electronic circuitry is configured to program the conductance values of the resistive memory elements by an iterative program and verify procedure.
4. A sensor device according to claim 1, wherein the memristive array comprises a plurality of row lines; a plurality of column lines; and a plurality of junctions arranged between the plurality of row lines and the plurality of column lines,

wherein each junction comprises a programmable resistive memory element.

5. A sensor device according to claim 4, wherein the electronic circuitry comprises a readout circuit configured to apply read voltages to the row lines and/or column lines of the memristive array; read out current values of the row lines and/or column lines of the memristive array; wherein the read voltages represent vector values of a vector of a matrix-vector multiplication; and the current values represent result values of vector elements of a product vector of the matrix-vector multiplications.
6. A sensor device according to claim 4, wherein the plurality of junctions comprise a serial arrangement of a resistive memory element and a transistor.
7. A sensor device according to claim 1, wherein the computational memory comprises a first memristive array for programming a measurement matrix and a second memristive array for programming a transpose of the measurement matrix.
8. A sensor device according to claim 1, wherein the reconstruction algorithm is an approximate message passing algorithm.
9. A sensor device according to claim 1, wherein the reconstruction algorithm comprises an integrated de-noising functionality.
10. A sensor device according to claim 1, wherein the device is configured to perform a block-based compression and reconstruction.
11. A sensor device as claimed in claim 1, wherein the resistive memory elements are one of Phase change memory (PCM) elements, Conductive bridge resistive memory elements, Metal-oxide resistive random access memory (RRAM) elements, Magneto-resistive random access memory (MRAM) elements, Ferroelectric random access memory (FeRAM) elements, optical memory elements, and a system device, the system device comprising transistors, resistors, capacitors, and/or inductors configured to jointly emulate a behavior of a resistive memory element.
12. A sensor device as claimed in claim 11, wherein the resistive memory elements are phase change memory elements and wherein the device is configured to: apply a Reset-pulse to the phase change memory elements in order to bring the phase change memory elements in the amorphous state; apply as programming signals current pulses to the phase change memory elements that heat the phase change memory elements above the crystallization temperature, thereby lowering the conductance of the phase change memory elements to a desired conductance value.
13. A method for signal compression and reconstruction, the method comprising: receiving, by a sensor device, an input signal, the sensor device comprising at least a computational memory and electronic circuitry, wherein the computational memory comprises at least one memristive array comprising at least a plurality of resistive memory elements, the resistive memory elements being arranged in a crossbar topology; computing, by the computational memory, a compressed signal from the input signal; performing, by the electronic circuitry, a reconstruction algorithm to compute a reconstructed signal from the compressed signal;

15

computing, by the computational memory, partial results of the reconstruction algorithm; and providing, by the computational memory, the partial results to the electronic circuitry.

14. A method according to claim 13, further comprising applying programming signals to the resistive memory elements of the computational memory to program conductance values as a measurement matrix; compressing the input signal by performing a matrix-vector multiplication of the input signal with the measurement matrix; and computing the partial results of the reconstruction algorithm by performing matrix-vector multiplications with the measurement matrix.

15. A method according to claim 13, further comprising: applying read voltages to row lines and/or column lines of the memristive array of the computational memory; reading out current values of the row lines and/or column lines of the memristive array; wherein the read voltages represent vector values of a vector of a matrix-vector multiplication; and the current values represent result values of vector elements of a product vector of the matrix-vector multiplication.

16. A method according to claim 13, wherein the reconstruction algorithm is an approximate message passing algorithm.

16

17. A design structure tangibly embodied in a machine readable medium for designing, manufacturing, or testing an integrated circuit, the design structure comprising:

a sensor device comprising a computational memory and electronic circuitry;

the sensor device being configured to receive an input signal;

compress the input signal into a compressed signal; and compute a reconstructed signal from the compressed signal;

wherein the electronic circuitry is configured to perform a reconstruction algorithm to compute the reconstructed signal; and

the computational memory is configured to compute the compressed signal and partial results of the reconstruction algorithm,

wherein the computational memory comprises at least one memristive array comprising a plurality of resistive memory elements, the resistive memory elements being arranged in a crossbar topology.

18. A design structure according to claim 17, wherein the memristive array comprises:

a plurality of row lines;

a plurality of columns lines; and

a plurality of junctions arranged between the plurality of row lines and the plurality of column lines, wherein each junction comprises a programmable resistive memory element.

* * * * *

专利名称(译)	具有电阻存储器的传感器设备，用于信号压缩和重建		
公开(公告)号	US10424370	公开(公告)日	2019-09-24
申请号	US16/031041	申请日	2018-07-10
[标]申请(专利权)人(译)	国际商业机器公司		
申请(专利权)人(译)	国际商业机器公司		
当前申请(专利权)人(译)	国际商业机器公司		
[标]发明人	LE GALLO BOURDEAU MANUEL SEBASTIAN ABU CHERUBINI GIOVANNI		
发明人	LE GALLO-BOURDEAU, MANUEL SEBASTIAN, ABU CHERUBINI, GIOVANNI		
IPC分类号	G11C13/00 G06F17/16 H04N5/378 H03M1/12 G06T9/00 G06K9/40 A61B5/00		
CPC分类号	G06F17/16 G11C13/004 G11C13/0004 G11C13/0064 G11C13/0069 H04N5/378 G06K9/40 G11C2213/79 A61B5/0033 H03M1/12 G06T9/00 A61B5/7203 A61B5/726 A61B2560/0475 G06F17/10 G06K9/20 G11C7/1006 G11C13/0002 G11C2213/15 G11C2213/77 H03M7/3062 H04N5/335 H04N19/60 H04N19/90 H03M7/30		
代理机构(译)	斯卡利SCOTT，墨菲和压脚，P.C.		
优先权	62/576084 2017-10-24 US		
其他公开文献	US20190122727A1		
外部链接	Espacenet		

摘要(译)

一种传感器设备，包括计算存储器和电子电路。传感器设备被配置为接收输入信号，将输入信号压缩为压缩信号并从压缩信号计算重构信号。电子电路被配置为执行重构算法以计算重构的信号。计算存储器被配置为计算压缩信号和重建算法的部分结果。可以提供相关的方法和相关的设计结构。

