



US010299755B2

(12) **United States Patent**
Tieu

(10) **Patent No.:** **US 10,299,755 B2**
(45) **Date of Patent:** **May 28, 2019**

(54) **SYSTEM AND METHOD FOR LOCATING DETACHMENT ZONE OF A DETACHABLE IMPLANT**

A61B 17/12109; A61B 17/12113; A61B 17/1214; A61B 17/12122; A61B 2017/1205; A61B 2017/12054; A61B 2017/12068

(71) Applicant: **MicroVention, Inc.**, Tustin, CA (US)

See application file for complete search history.

(72) Inventor: **Tai D. Tieu**, Fountain Valley, CA (US)

(56) **References Cited**

(73) Assignee: **MicroVention, Inc.**, Aliso Viejo, CA (US)

U.S. PATENT DOCUMENTS

(*) Notice: Subject to any disclaimer, the term of this patent is extended or adjusted under 35 U.S.C. 154(b) by 336 days.

4,346,712 A 8/1982 Handa et al.
4,364,392 A 12/1982 Strother et al.
(Continued)

(21) Appl. No.: **14/975,224**

FOREIGN PATENT DOCUMENTS

(22) Filed: **Dec. 18, 2015**

AU 2005/276980 B2 3/2006
CA 2493016 A1 2/2004
(Continued)

(65) **Prior Publication Data**

US 2016/0100819 A1 Apr. 14, 2016

OTHER PUBLICATIONS

Related U.S. Application Data

United States Patent and Trademark Office, Notice of Allowance dated Sep. 28, 2015 in U.S. Appl. No. 12/340,546, 9 pages.

(62) Division of application No. 12/340,546, filed on Dec. 19, 2008, now Pat. No. 9,242,070.

(Continued)

(Continued)

Primary Examiner — Katherine M Rodjom

(74) *Attorney, Agent, or Firm* — Inskeep IP Group, Inc.

(51) **Int. Cl.**

A61B 5/00 (2006.01)
A61F 2/966 (2013.01)

(Continued)

(57) **ABSTRACT**

A system and method for quickly detaching an implant and for locating the detachment zone of a detachable implant. A sensor determines a sudden change in the local environment as the sensor passes from within a microcatheter to being exposed to the vasculature. The sensor may be a temperature sensor, ultrasonic sensor, pressure sensor or the like. If the detachable implant assembly uses a heater coil to detach the implant, the heater coil may be used as a sensor. Additionally, the implant itself may be used as a sensor if a change in electrical resistance is detectable as the implant exits the microcatheter and changes shape.

(52) **U.S. Cl.**

CPC **A61B 8/0841** (2013.01); **A61B 17/1214** (2013.01); **A61B 17/12022** (2013.01); **A61B 17/12109** (2013.01); **A61B 17/12113** (2013.01); **A61B 17/12122** (2013.01); **A61B 17/12154** (2013.01); **A61F 2/95** (2013.01);

(Continued)

(58) **Field of Classification Search**

CPC ... A61F 2/95; A61B 8/0841; A61B 17/12022;

6 Claims, 6 Drawing Sheets

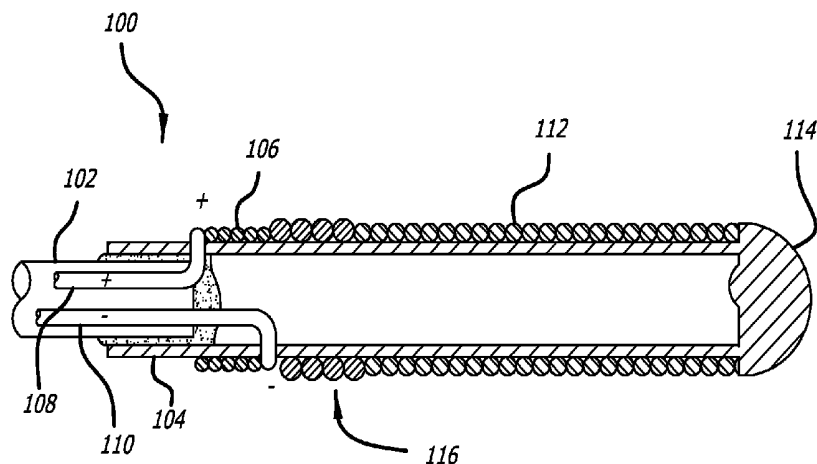

Related U.S. Application Data					
		5,443,454 A	8/1995	Tanabe et al.	
		5,443,478 A	8/1995	Purdy	
		5,443,495 A	8/1995	Buscemi et al.	
(60)	Provisional application No. 61/016,154, filed on Dec. 21, 2007.	5,469,867 A	11/1995	Schmitt	
		5,470,338 A	11/1995	Whitfield et al.	
		5,476,472 A	12/1995	Dormandy	
(51)	Int. Cl.	5,498,227 A	3/1996	Mawad	
	<i>A61B 8/08</i> (2006.01)	5,498,250 A	3/1996	Prather	
	<i>A61B 17/12</i> (2006.01)	5,522,836 A	6/1996	Palermo	
	<i>A61F 2/95</i> (2013.01)	5,525,334 A	6/1996	Ito et al.	
	<i>A61M 25/00</i> (2006.01)	5,529,653 A	6/1996	Glastra	
	<i>A61M 25/01</i> (2006.01)	5,540,680 A	6/1996	Guglielmi et al.	
	<i>A61F 2/30</i> (2006.01)	5,536,274 A	7/1996	Neuss	
	<i>A61M 25/06</i> (2006.01)	5,569,245 A	10/1996	Guglielmi et al.	
	<i>A61B 17/00</i> (2006.01)	5,578,074 A	11/1996	Mirigian	
	<i>A61B 34/20</i> (2016.01)	5,580,568 A	12/1996	Greff et al.	
		5,582,619 A	12/1996	Ken	
(52)	U.S. Cl.	5,593,412 A	1/1997	Martinez et al.	
	CPC	5,601,600 A	2/1997	Ton	
	<i>A61F 2/966</i> (2013.01); <i>A61M 25/0082</i>	5,609,608 A	3/1997	Benett et al.	
	(2013.01); <i>A61M 25/0108</i> (2013.01); <i>A61B</i>	5,612,050 A	3/1997	Rowe et al.	
	<i>2017/00292</i> (2013.01); <i>A61B 2017/12068</i>	5,614,204 A	3/1997	Cochrum	
	(2013.01); <i>A61B 2034/2053</i> (2016.02); <i>A61B</i>	5,624,449 A	4/1997	Pham et al.	
	<i>2562/0247</i> (2013.01); <i>A61B 2562/0257</i>	5,624,461 A	4/1997	Mariant	
	(2013.01); <i>A61B 2562/0271</i> (2013.01); <i>A61F</i>	5,624,685 A	4/1997	Takahashi et al.	
	<i>2002/30668</i> (2013.01); <i>A61F 2002/9505</i>	5,634,936 A	6/1997	Linden et al.	
	(2013.01); <i>A61F 2250/0001</i> (2013.01); <i>A61M</i>	5,639,277 A	6/1997	Mariant et al.	
	<i>25/0068</i> (2013.01); <i>A61M 2025/0042</i>	5,645,558 A	7/1997	Horton	
	(2013.01); <i>A61M 2025/0681</i> (2013.01); <i>A61M</i>	5,658,308 A	8/1997	Snyder	
	<i>2205/3331</i> (2013.01); <i>A61M 2205/3368</i>	5,667,767 A	9/1997	Greff et al.	
	(2013.01); <i>A61M 2205/3375</i> (2013.01); <i>A61M</i>	5,669,931 A	9/1997	Kupiecki et al.	
	<i>2205/3653</i> (2013.01)	5,690,667 A	11/1997	Gia	
		5,690,671 A	11/1997	McGurk et al.	
		5,700,258 A	12/1997	Mirigian et al.	
		5,702,361 A	12/1997	Evans et al.	
		5,718,711 A	2/1998	Berenstein et al.	
(56)	References Cited	5,722,989 A	3/1998	Fitch et al.	
	U.S. PATENT DOCUMENTS	5,725,568 A	3/1998	Hastings	
		5,733,329 A	3/1998	Wallace et al.	
		5,743,905 A	4/1998	Eder et al.	
		5,749,891 A	5/1998	Ken et al.	
		5,749,894 A	5/1998	Engelson	
		5,749,921 A	5/1998	Lenker et al.	
		5,750,585 A	5/1998	Park et al.	
		5,759,161 A	6/1998	Ogawa et al.	
		5,766,204 A	6/1998	Porter et al.	
		5,766,219 A	6/1998	Horton	
		5,792,154 A	8/1998	Doan et al.	
		5,800,454 A	9/1998	Jacobsen et al.	
		5,800,455 A	9/1998	Palermo et al.	
		5,814,062 A	9/1998	Sepetka et al.	
		5,823,198 A	10/1998	Jones et al.	
		5,830,178 A	11/1998	Jones et al.	
		5,830,230 A	11/1998	Berryman et al.	
		5,846,210 A	12/1998	Ogawa et al.	
		5,846,247 A	12/1998	Unsworth et al.	
		5,851,206 A	12/1998	Guglielmi et al.	
		5,851,508 A	12/1998	Greff et al.	
		5,853,418 A	12/1998	Ken et al.	
		5,891,058 A	4/1999	Taki et al.	
		5,891,130 A	4/1999	Palermo et al.	
		5,895,385 A	4/1999	Guglielmi et al.	
		5,902,254 A	5/1999	Magram	
		5,911,737 A	6/1999	Lee et al.	
		5,925,037 A	7/1999	Guglielmi et al.	
		5,925,059 A	7/1999	Palermo et al.	
		5,925,061 A	7/1999	Ogi et al.	
		5,941,888 A	8/1999	Wallace et al.	
		5,944,733 A	8/1999	Engelson	
		5,947,963 A	9/1999	Guglielmi	
		5,964,771 A	10/1999	Beyar et al.	
		5,964,797 A	10/1999	Ho	
		5,976,126 A	11/1999	Guglielmi et al.	
		5,976,131 A	11/1999	Guglielmi et al.	
		5,984,629 A	11/1999	Brodersen et al.	
		6,010,498 A	1/2000	Guglielmi	
		6,013,084 A	1/2000	Ken et al.	
		6,015,424 A	1/2000	Rosenbluth et al.	
		6,033,423 A	3/2000	Ken et al.	

(56)

References Cited

U.S. PATENT DOCUMENTS

6,048,338	A	4/2000	Larson et al.	7,137,990	B2	11/2006	Herbert et al.
6,053,873	A	4/2000	Govari et al.	7,147,618	B2	12/2006	Kurz
6,056,759	A	5/2000	Fiedler	7,166,122	B2	1/2007	Aganon et al.
6,059,815	A	5/2000	Lee et al.	7,179,276	B2	2/2007	Barry et al.
6,063,070	A	5/2000	Eder	7,182,774	B2	2/2007	Barry et al.
6,063,100	A	5/2000	Diaz et al.	7,198,613	B2	4/2007	Gandhi et al.
6,066,133	A	5/2000	Guglielmi et al.	7,201,768	B2	4/2007	Diaz et al.
6,068,644	A	5/2000	Lulo et al.	7,208,003	B2	4/2007	Davis et al.
6,083,220	A	7/2000	Guglielmi et al.	7,238,194	B2	7/2007	Monstdt et al.
6,086,599	A	7/2000	Lee et al.	7,255,707	B2	8/2007	Ramzipoor et al.
6,091,980	A	7/2000	Squire et al.	7,264,628	B2	9/2007	Jones et al.
6,102,932	A	8/2000	Kurz	7,270,674	B2	9/2007	Jones et al.
6,117,142	A	9/2000	Goodson et al.	7,309,345	B2	12/2007	Wallace
6,159,206	A	12/2000	Ogawa	7,323,000	B2	1/2008	Monstdt et al.
6,165,178	A	12/2000	Bashiri et al.	7,344,558	B2	3/2008	Lorenzo et al.
6,193,728	B1	2/2001	Ken et al.	7,351,254	B2	4/2008	Magers
6,221,066	B1	4/2001	Ferrera et al.	7,357,809	B2	4/2008	Jones et al.
6,224,609	B1	5/2001	Ressemann et al.	7,367,987	B2	5/2008	Balgobin et al.
6,238,403	B1	5/2001	Greene, Jr. et al.	7,371,251	B2	5/2008	Mitelberg et al.
6,238,415	B1	5/2001	Sepetka et al.	7,371,252	B2	5/2008	Balgobin et al.
6,277,126	B1	8/2001	Barry et al.	7,377,932	B2	5/2008	Mitelberg et al.
6,293,960	B1	9/2001	Ken	7,513,878	B2	4/2009	Hamilton
6,296,622	B1	10/2001	Kurz et al.	7,553,321	B2	6/2009	Litzenberg et al.
6,299,619	B1	10/2001	Greene, Jr. et al.	7,575,582	B2	8/2009	Gandhi et al.
6,319,267	B1	11/2001	Kurz	7,578,826	B2	8/2009	Gandhi et al.
6,338,657	B1	1/2002	Harper et al.	7,582,101	B2	9/2009	Jones et al.
6,361,547	B1	3/2002	Hieshima	7,591,833	B2	9/2009	Jones et al.
6,371,979	B1	4/2002	Beyar et al.	7,608,089	B2	10/2009	Wallace et al.
6,375,668	B1	4/2002	Gifford et al.	7,628,797	B2	12/2009	Tieu et al.
6,375,669	B1	4/2002	Rosenbluth et al.	7,651,513	B2	1/2010	Teoh et al.
6,383,204	B1	5/2002	Ferrera et al.	7,691,118	B2	4/2010	Gorospe
6,425,893	B1	7/2002	Guglielmi	7,708,754	B2	5/2010	Balgobin et al.
6,428,557	B1	8/2002	Hilaire	7,708,755	B2	5/2010	Davis, III et al.
6,440,098	B1	8/2002	Luscher	7,740,637	B2	6/2010	Gandhi et al.
6,447,522	B2	9/2002	Gambale et al.	7,771,451	B2	8/2010	Ramzipoor
6,478,773	B1	11/2002	Gandhi	7,776,054	B2	8/2010	Gandhi et al.
6,494,884	B2	12/2002	Gifford, III et al.	7,780,680	B2	8/2010	Gandhi et al.
6,500,149	B2	12/2002	Gandhi et al.	7,789,891	B2	9/2010	Wallace
6,514,264	B1	2/2003	Naglireiter	2001/0029352	A1	10/2001	Gandhi et al.
6,526,979	B1	3/2003	Nikolchev et al.	2002/0091380	A1	7/2002	Wheelock et al.
6,544,225	B1	4/2003	Lulo et al.	2002/0107534	A1	8/2002	Schaefer et al.
6,554,849	B1	4/2003	Jones et al.	2002/0188341	A1	12/2002	Elliott
6,602,261	B2	8/2003	Greene, Jr. et al.	2003/0023262	A1	1/2003	Welch
6,602,269	B2	8/2003	Wallace et al.	2003/0045901	A1	3/2003	Opolski
6,607,538	B1	8/2003	Ferrera et al.	2003/0069539	A1	4/2003	Gandhi et al.
6,610,046	B1	8/2003	Usami et al.	2003/0125790	A1	7/2003	Fastovsky et al.
6,634,361	B1	10/2003	Nikolchev et al.	2004/0002731	A1	1/2004	Aganon et al.
6,645,240	B2	11/2003	Yee	2004/0002733	A1	1/2004	Teoh
6,656,173	B1	12/2003	Palermo	2004/0034363	A1	2/2004	Wilson et al.
6,684,884	B2	2/2004	Nikolchev et al.	2004/0044385	A1	3/2004	Fenn et al.
6,689,141	B2	2/2004	Ferrera et al.	2004/0204701	A1	10/2004	Cox et al.
6,705,323	B1	3/2004	Nikolchev et al.	2005/0021023	A1	1/2005	Guglielmi et al.
6,716,238	B2	4/2004	Elliott	2005/0043755	A1	2/2005	Wilson et al.
6,740,073	B1	5/2004	Saville	2005/0118865	A1	6/2005	Henningsen
6,743,236	B2	6/2004	Bary et al.	2005/0131523	A1	6/2005	Bashiri et al.
6,743,251	B1	6/2004	Eder	2005/0149108	A1	7/2005	Cox
6,807,446	B2	10/2004	Fenn et al.	2005/0154417	A1	7/2005	Sepetka et al.
6,849,081	B2	2/2005	Sepetka et al.	2005/0171572	A1	8/2005	Martinez
6,849,087	B1	2/2005	Chuter	2005/0222580	A1	10/2005	Gifford, III et al.
6,855,125	B2	5/2005	Shanley	2005/0283182	A1	12/2005	Pierce et al.
6,905,503	B2	6/2005	Gifford, III et al.	2006/0025801	A1	2/2006	Lulo et al.
6,953,465	B2	10/2005	Dieck et al.	2006/0025803	A1	2/2006	Mitelberg et al.
6,953,473	B2	10/2005	Porter	2006/0036280	A1	2/2006	French et al.
6,958,068	B2	10/2005	Hieshima	2006/0052815	A1	3/2006	Fitz et al.
6,964,671	B2	11/2005	Cheng et al.	2006/0079923	A1	4/2006	Chhabra et al.
6,966,892	B2	11/2005	Gandhi et al.	2006/0116708	A1	6/2006	Ogawa et al.
6,989,020	B2	1/2006	Jones et al.	2006/0135986	A1	6/2006	Wallace et al.
7,001,422	B2	2/2006	Escamilla et al.	2006/0173488	A1	8/2006	Takeuchi et al.
7,014,645	B2	3/2006	Greene, Jr. et al.	2006/0184092	A1	8/2006	Atanasoska et al.
7,048,719	B1	5/2006	Monetti	2006/0200192	A1	9/2006	Fitz et al.
7,063,671	B2	6/2006	Couvillon, Jr.	2006/0241682	A1	10/2006	Kurz
7,063,707	B2	6/2006	Bose et al.	2006/0241684	A1	10/2006	Wilson et al.
7,066,904	B2	6/2006	Rosenthal et al.	2006/0241685	A1	10/2006	Wilson et al.
7,070,609	B2	7/2006	West	2006/0253023	A1	11/2006	Lewis et al.
7,108,708	B2	9/2006	Cheng et al.	2006/0253149	A1	11/2006	Gandhi et al.
				2006/0271098	A1	11/2006	Peacock, III
				2006/0271099	A1	11/2006	Marks et al.
				2006/0276826	A1	12/2006	Mitelberg et al.
				2007/0055302	A1	3/2007	Henry et al.

(56)

References Cited

U.S. PATENT DOCUMENTS

2007/0100419 A1 5/2007 Licata et al.
 2007/0104752 A1 5/2007 Lee et al.
 2007/0167911 A1 7/2007 Gandhi et al.
 2007/0185443 A1 8/2007 Euteneuer et al.
 2007/0185457 A1 8/2007 Euteneuer et al.
 2007/0191879 A1 8/2007 Gandhi et al.
 2007/0208276 A1 9/2007 Kornkven Volk et al.
 2007/0239141 A1 10/2007 Hartley et al.
 2007/0239193 A1 10/2007 Simon et al.
 2008/0103585 A1 5/2008 Monstadt et al.
 2008/0119887 A1 5/2008 Que et al.
 2008/0125855 A1 5/2008 Henkes et al.
 2008/0133028 A1 6/2008 Wilson et al.
 2008/0140111 A1 6/2008 Wilson et al.
 2008/0140178 A1 6/2008 Rasmussen et al.
 2008/0147201 A1 6/2008 Wilson et al.
 2008/0172119 A1 7/2008 Yamasaki et al.
 2008/0221554 A1 9/2008 O'Connor et al.
 2008/0283066 A1 11/2008 Delgado et al.
 2008/0287982 A1 11/2008 Harreld
 2009/0018653 A1 1/2009 Bashiri et al.
 2009/0054905 A1 2/2009 Levy
 2009/0062726 A1 3/2009 Ford et al.
 2009/0076540 A1 3/2009 Marks et al.
 2009/0099592 A1 4/2009 Buiser et al.
 2009/0138036 A1 5/2009 Nardone et al.
 2009/0143786 A1 6/2009 Bashiri et al.
 2009/0163780 A1 6/2009 Tieu
 2009/0163986 A1 6/2009 Tieu et al.
 2009/0177261 A1 7/2009 Teoh et al.
 2009/0270901 A1 10/2009 Kelleher et al.
 2009/0270903 A1 10/2009 Litzenberg et al.
 2009/0275971 A1 11/2009 Kelleher et al.
 2009/0299275 A1 12/2009 Gandhi et al.
 2009/0318892 A1 12/2009 Aboytes et al.
 2010/0004731 A1 1/2010 Gandhi et al.
 2010/0042133 A1 2/2010 Ramzipoor et al.
 2010/0069838 A1 3/2010 Weber et al.
 2010/0094395 A1 4/2010 Kellett
 2010/0106162 A1 4/2010 Jaeger et al.
 2010/0152650 A1 6/2010 Schrodt
 2010/0152828 A1 6/2010 Pakbaz et al.
 2010/0160944 A1 6/2010 Teoh et al.
 2010/0160953 A1 6/2010 Ngo et al.
 2010/0234872 A1 9/2010 Guo et al.
 2010/0249823 A1 9/2010 Gandhi et al.
 2010/0256666 A1 10/2010 Chen et al.
 2010/0268158 A1 10/2010 Porter
 2010/0268201 A1 10/2010 Tieu et al.
 2010/0268204 A1 10/2010 Tieu et al.
 2010/0268252 A1 10/2010 Chen et al.

FOREIGN PATENT DOCUMENTS

CN 101589972 A 12/2009
 CN 20110506 A 5/2011
 EP 0547530 A1 6/1993
 EP 0707830 A1 4/1996
 EP 0719522 A1 7/1996
 EP 0941703 A1 9/1999
 EP 0941704 A1 9/1999
 EP 0948935 A1 10/1999
 EP 0992220 A1 10/1999
 EP 1010396 A1 6/2000
 EP 1073377 A1 2/2001
 EP 0824010 B1 2/2003
 EP 1188413 A3 7/2003
 EP 0830873 B1 4/2004
 EP 1513461 A 3/2005
 EP 1538997 B1 6/2005
 EP 1266629 B1 11/2006
 EP 1738698 A2 1/2007
 EP 1791590 A 6/2007
 EP 1797832 A1 6/2007
 EP 1797833 A1 6/2007

EP 1621150 B1 9/2007
 EP 1621148 B1 10/2007
 EP 1339328 B1 2/2008
 EP 1621149 B1 2/2008
 EP 1889577 A1 2/2008
 EP 1738694 B1 7/2008
 EP 1743600 B1 7/2008
 EP 1738696 B1 8/2008
 EP 1255492 B1 10/2008
 EP 1792576 B1 10/2008
 EP 1795133 B1 10/2008
 EP 1255493 B1 11/2008
 EP 1738693 B1 11/2008
 EP 1992308 A2 11/2008
 EP 1813196 B1 12/2008
 EP 1120088 B1 4/2009
 EP 1825823 B1 6/2009
 EP 1738697 B1 4/2010
 EP 1792575 B1 6/2010
 EP 2131754 B1 6/2010
 EP 2231030 A 9/2010
 EP 2234562 A 10/2010
 EP 1985240 B1 2/2011
 EP 1886632 B1 4/2011
 EP 2319455 A2 5/2011
 EP 1813213 B1 12/2011
 EP 2111828 B1 2/2012
 JP 52141092 A 11/1977
 JP 56043962 A 4/1981
 JP 01-238874 A 9/1989
 JP 5158069 A 6/1992
 JP 07-265431 A 10/1995
 JP H08506033 A 7/1996
 JP 2008-250576 A 4/1998
 JP 2003-521991 A 7/2003
 JP 2005-524479 A 8/2005
 JP 2008-510594 A 4/2008
 JP 2011-507636 A 3/2011
 JP 2011-507638 A 3/2011
 WO WO1991/013592 A1 9/1991
 WO WO1994/006503 A1 3/1994
 WO WO1994/010936 A1 5/1994
 WO WO1995/007667 A1 3/1995
 WO WO1995/023558 A1 9/1995
 WO WO1995/027443 A1 10/1995
 WO WO1996/000034 A1 1/1996
 WO WO1996/000104 A1 1/1996
 WO WO1997/026939 A1 7/1997
 WO WO1997/027888 A1 8/1997
 WO WO1998/029042 A1 7/1998
 WO WO1998/037816 A1 9/1998
 WO WO1998/040033 A3 9/1998
 WO WO1999/002094 A1 1/1999
 WO WO1999/006097 A1 2/1999
 WO WO1999/009894 A1 3/1999
 WO WO1999/029260 A2 6/1999
 WO WO1999/040852 A1 8/1999
 WO WO1999/042059 A2 8/1999
 WO WO1999/055239 A1 11/1999
 WO WO2000/012031 A1 3/2000
 WO WO2000/021443 A1 4/2000
 WO WO2000/053105 A1 9/2000
 WO WO2000/072781 A2 12/2000
 WO WO 2001/021244 A1 3/2001
 WO WO2001/058366 A1 8/2001
 WO WO2002/032326 A2 4/2002
 WO WO2003/094751 A1 11/2003
 WO WO2005/035020 A2 4/2005
 WO WO2005/077281 A1 8/2005
 WO WO2005/113035 A3 12/2005
 WO WO2006/024040 A2 3/2006
 WO WO2006/047748 A2 5/2006
 WO WO2006/069123 A1 6/2006
 WO WO2006/081448 A1 8/2006
 WO WO2006/104881 A2 10/2006
 WO WO2006/114325 A2 11/2006
 WO WO2006/130743 A1 12/2006
 WO WO2007/041407 A1 4/2007
 WO WO2007/053568 A1 5/2007

(56)

References Cited

FOREIGN PATENT DOCUMENTS

WO WO2007/070788 A2 6/2007
 WO WO2007/070792 A2 6/2007
 WO WO2007/070793 A2 6/2007
 WO WO2007/070797 A2 6/2007
 WO WO2007/118015 A2 10/2007
 WO WO2007/121405 A2 10/2007
 WO WO2007/123657 A2 11/2007
 WO WO 2007/124289 11/2007
 WO WO2008/064205 A2 5/2008
 WO WO2008/064206 A2 5/2008
 WO WO2008/064209 A1 5/2008
 WO WO2008/066923 A1 6/2008
 WO WO2008/085606 A1 7/2008
 WO WO2008/109394 A2 9/2008
 WO WO2008/115544 A2 9/2008
 WO WO2009/012057 A2 1/2009
 WO WO2009/014883 A1 1/2009
 WO WO2009/073398 A1 6/2009
 WO WO2009/082716 A1 7/2009
 WO WO2009/086214 A1 7/2009
 WO WO2009/088969 A2 7/2009
 WO WO2009/154844 A1 12/2009
 WO WO2010/030348 A1 3/2010
 WO WO2010/045079 A1 4/2010
 WO WO2010/104955 A1 9/2010
 WO WO2010/117883 A1 10/2010
 WO WO2010/120653 A1 10/2010
 WO WO2010/120694 A1 10/2010
 WO WO2010/121037 A1 10/2010
 WO WO2010/121049 A1 10/2010

OTHER PUBLICATIONS

United States Patent and Trademark Office, Final Office Action dated Oct. 9, 2014 in U.S. Appl. No. 12/340,546, 8 pages.
 United States Patent and Trademark Office, Final Office Action dated Jun. 9, 2014 in U.S. Appl. No. 12/340,546, 6 pages.
 United States Patent and Trademark Office, Office Action dated Dec. 6, 2013 in U.S. Appl. No. 12/340,546, 7 pages.
 United States Patent and Trademark Office, Final Office Action dated Aug. 15, 2012 in U.S. Appl. No. 12/340,546, 9 pages.
 United States Patent and Trademark Office, Notice of Allowance dated Feb. 15, 2012 in U.S. Appl. No. 12/340,616, 17 pages.
 United States Patent and Trademark Office, Office Action dated Jan. 23, 2012 in U.S. Appl. No. 12/340,546, 6 pages.

United States Patent and Trademark Office, Final Office Action dated Oct. 26, 2011 in U.S. Appl. No. 12/340,616, 13 pages.
 United States Patent and Trademark Office, Office Action dated Apr. 12, 2011 in U.S. Appl. No. 12/340,616, 13 pages.
 United States Patent and Trademark Office, Office Action dated Sep. 3, 2010 in U.S. Appl. No. 12/340,616, 14 pages.
 WIPO, U.S. International Search Authority, International Search Report dated Mar. 19, 2009 in International Patent Application No. PCT/US2008/087855, 2 pages.
 PCT International Search Report and Written Opinion for International Patent Application No. PCT/US2008/071325, dated Oct. 20, 2008, 10 pages, ISA/US, Alexandria, Virginia.
 United States Patent and Trademark Office, Office Action dated Nov. 20, 2008 in U.S. Appl. No. 12/275,126, 11 pages.
 Canadian Intellectual Property Office, Notice of Allowance dated Nov. 28, 2007 in Canadian Patent Application No. CA2425544, 1 page.
 Canadian Intellectual Property Office, Examiner's Report dated Feb. 19, 2007 in Canadian Patent Application No. CA2425544, 2 pages.
 Canadian Intellectual Property Office, Examiner's Report dated Sep. 29, 2005 in Canadian Patent Application No. CA2325544, 4 pages.
 IP Australia, Examination Report dated Jun. 27, 2005 in Australian Patent Application No. AU2002214623, 3 pages.
 United States Patent and Trademark Office, Notice of Allowance dated Oct. 2, 2003 in U.S. Appl. No. 10/143,724, 11 pages.
 WIPO, U.S. International Search Authority, International Search Report dated May 28, 2002 in International Patent Application No. PCT/US2001/032588, 5 pages.
 Graves, V.B. et al., "Endovascular Occlusion of the Carotid or Vertebral Artery with Temporary Proximal Flow Arrest and Microcoils: Clinical Results," *AJNR Am J Neuroradiol*, vol. 18, American Society of Neuroradiology, Aug. 1997, 6 pages.
 Schmutz, F. et al., "Embolization of Cerebral Arteriovenous Malformations with Silk: Histopathologic Changes and Hemorrhagic Complications," *AJNR Am J Neuroradiol*, vol. 18, American Society of Neuroradiology, Aug. 1997, 5 pages.
 Rosenthal M.D., D. et al., "Endovascular infrainguinal in situ saphenous vein bypass: A multicenter preliminary report," *J. Vasc Surg* Sep. 1992, vol. 3, No. 16, pp. 453-458, 6 pages.
 Rosenthal, D. et al., "Angioscope-assisted endovascular occlusion of venous tributaries: preclinical studies," *Cardiovasc Surg* Jun. 1993, vol. 1, No. 3, pp. 225-227, 3 pages.
 Vinuela M.D., F. et al., "Guglielmi detachable coil embolization of acute intracranial aneurysm: perioperative anatomical and clinical outcome in 403 patients," *J. Neurosurg*, vol. 86, Mar. 1997, 8 pages.

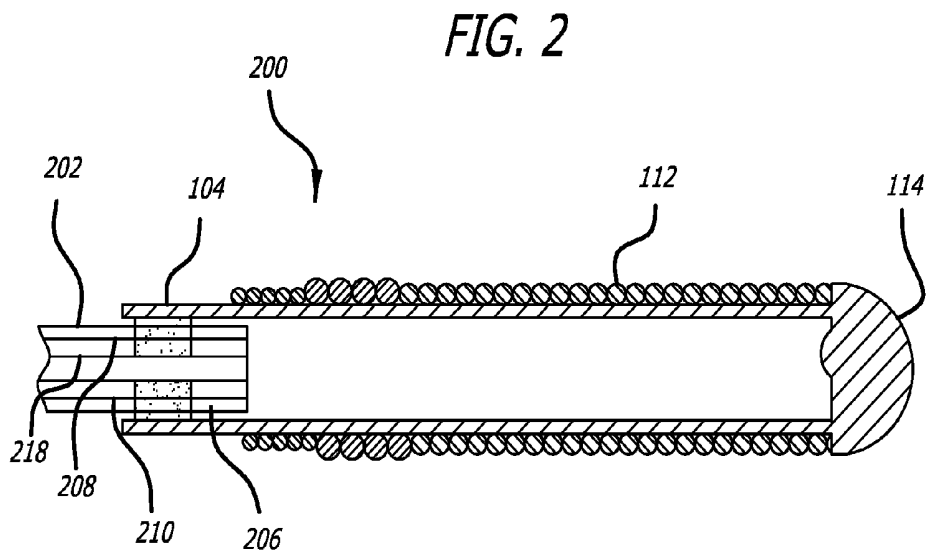
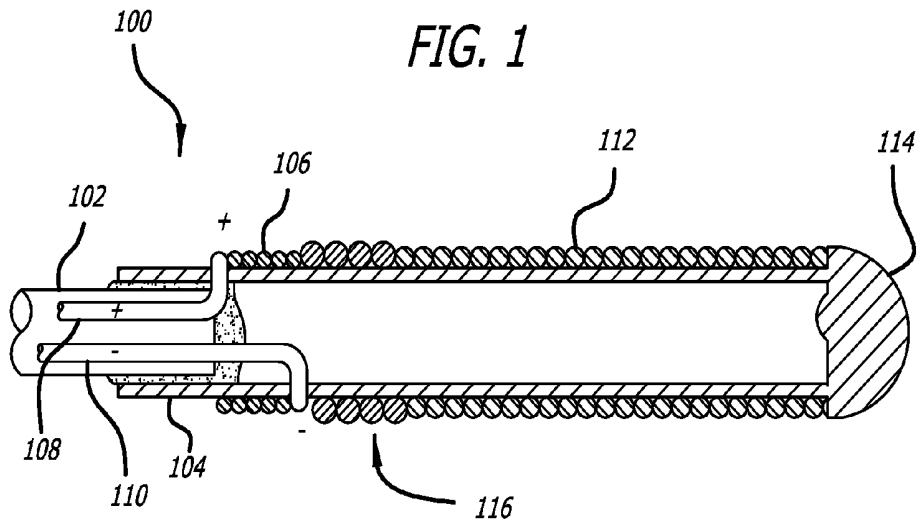

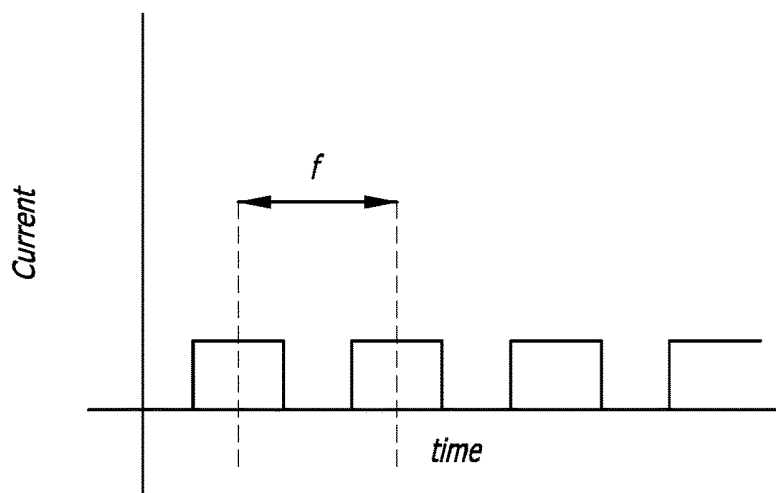

*Direct Current (DC)
Signaling*

FIG. 3A

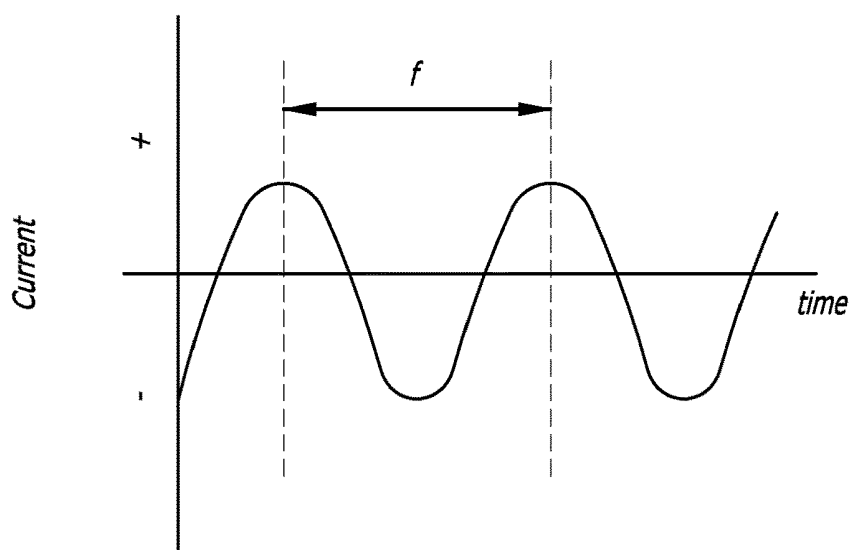

*Alternating Current (AC)
Signaling*

FIG. 3B

FIG. 4

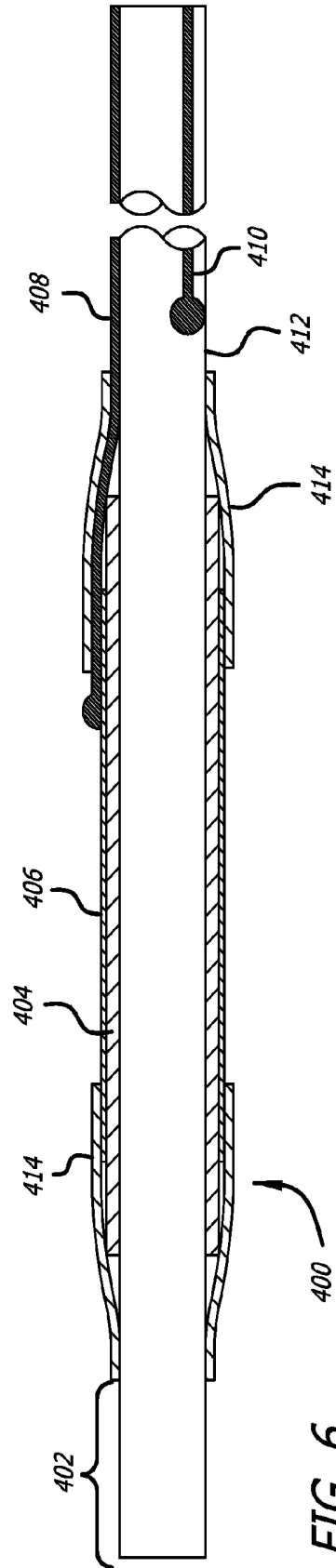
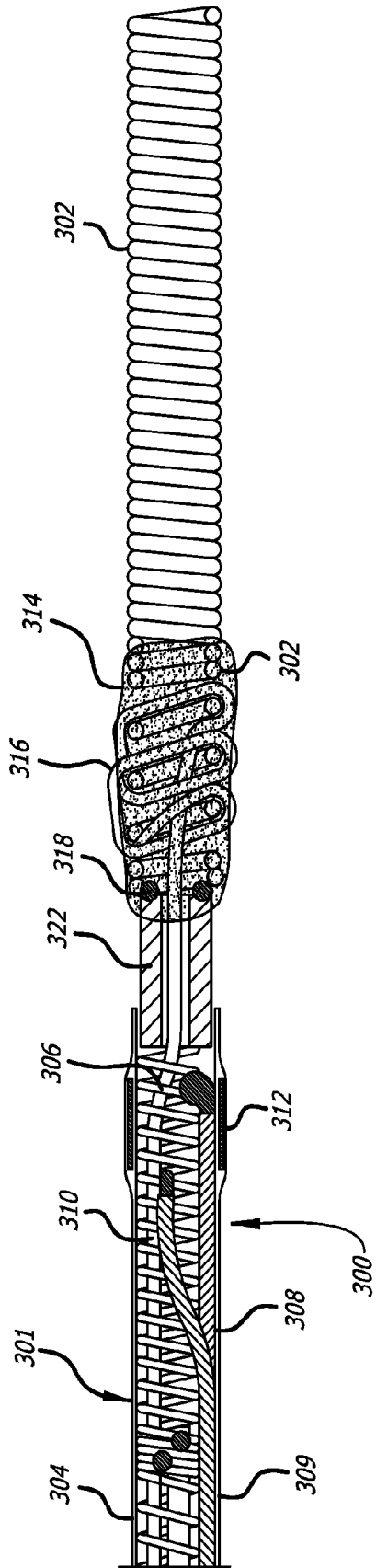

FIG. 6

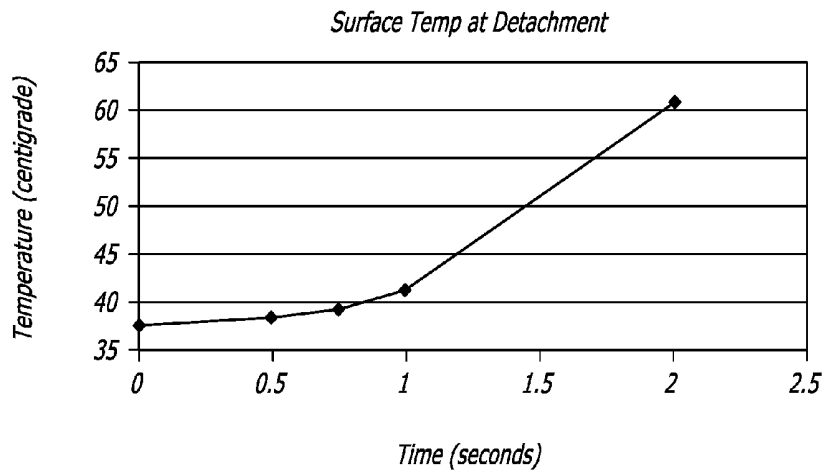

FIG. 5

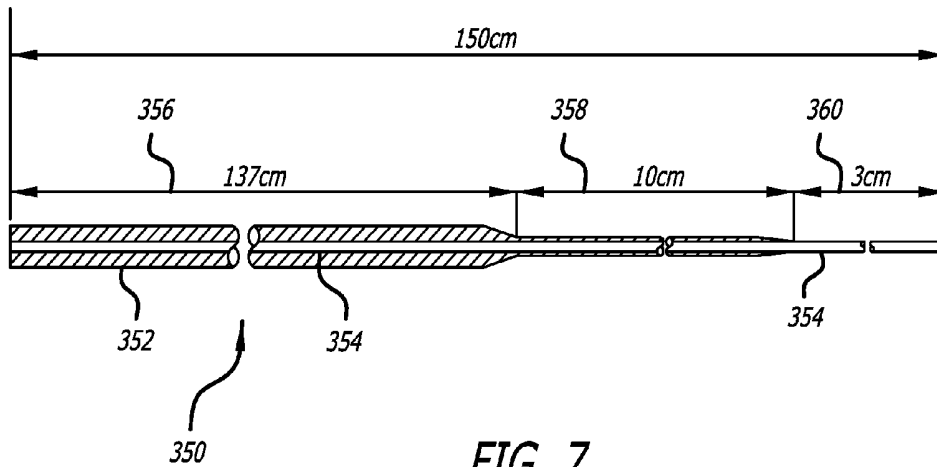
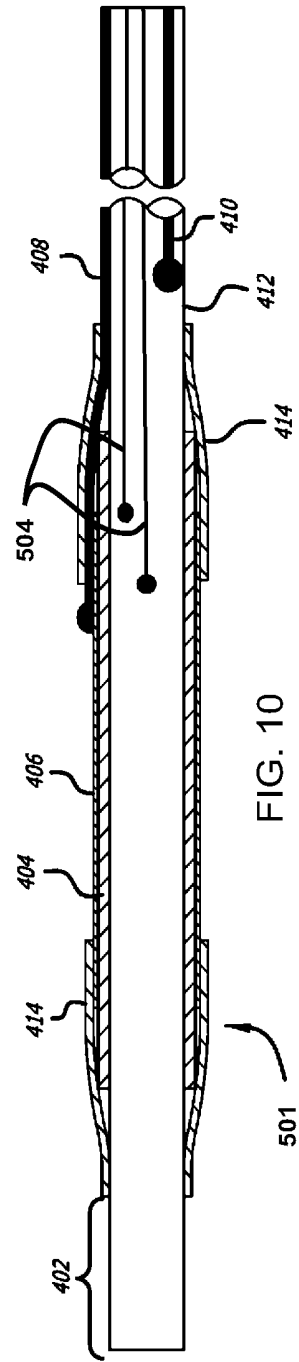
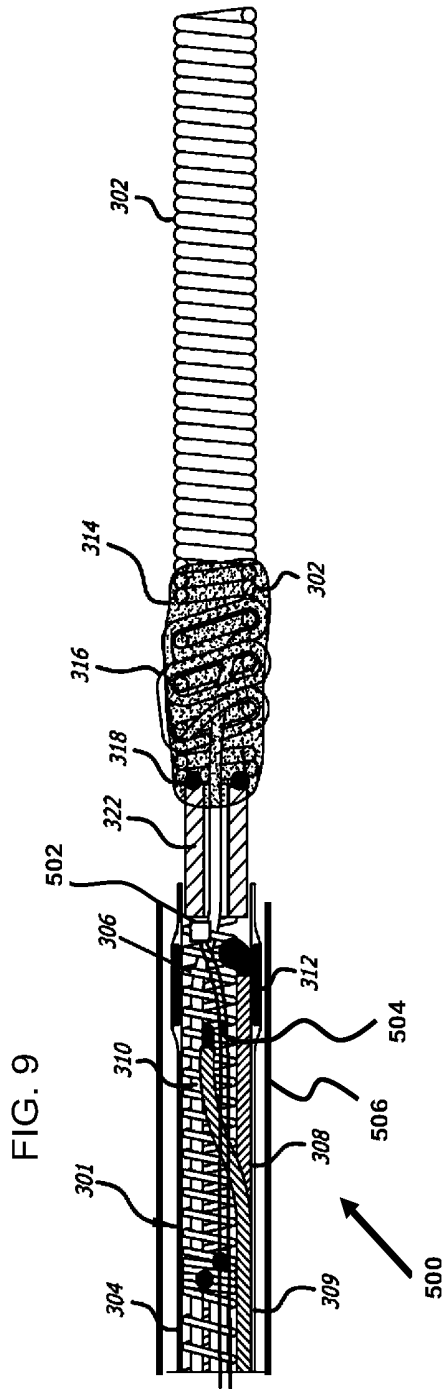

FIG. 7



SYSTEM AND METHOD FOR LOCATING DETACHMENT ZONE OF A DETACHABLE IMPLANT

RELATED APPLICATIONS

The present application is a divisional of U.S. patent application Ser. No. 12/340,546 filed Dec. 19, 2008 entitled System And Method For Locating Detachment Zone Of A Detachable Implant, which claims priority from U.S. Provisional Application Ser. No. 61/016,154, filed Dec. 21, 2007 entitled System and Method for Locating Detachment Zone of a Detachable Implant, both of which are incorporated by reference herein in their entireties. This application also incorporates by reference U.S. Provisional Application Ser. No. 60/604,671, filed Aug. 25, 2004 entitled Thermal Detachment System For Implantable Devices; U.S. Provisional Application Ser. No. 60/685,342 filed May 27, 2005 entitled Thermal Detachment System For Implantable Devices; U.S. patent application Ser. No. 11/212,830 filed Aug. 25, 2005 entitled Thermal Detachment System For Implantable Devices; U.S. Provisional Application Ser. No. 61/016,180, filed Dec. 21, 2007 entitled Method of Detecting Implant Detachment.

FIELD OF THE INVENTION

The present invention relates to systems and methods for delivering implant devices to a target site within the body of a patient. The present invention also relates to systems and methods for detecting a location of a detachment zone of a delivered implant device.

BACKGROUND OF THE INVENTION

Delivery of implantable therapeutic devices by less invasive means has been demonstrated to be desirable in numerous clinical situations. For example, vascular embolization has been used to control vascular bleeding, to occlude the blood supply to tumors, to occlude fallopian tubes, and to occlude vascular aneurysms, particularly intracranial aneurysms. In recent years, vascular embolization for the treatment of aneurysms has received much attention. As another example, the use of mesh or scaffold devices such as stents to open blocked vessels or to retain embolic coils have also received much attention.

Several different treatment modalities have been employed in the prior art for deploying implant devices. For example, numerous repositionable detachment systems for implant devices have been described in the prior art including U.S. Pat. No. 5,895,385 to Guglielmi et al. and U.S. Pat. No. 5,108,407 to Geremia et al., the contents of which are hereby incorporated by reference. Several systems, such as those disclosed in U.S. Pat. No. 6,500,149 to Gandhi et al. and U.S. Pat. No. 4,346,712 to Handa et al., the contents of which are hereby incorporated by reference, describe the use of a heater to detach and deploy the implant device.

Some percutaneously delivered detachable implant systems, such as those used to deliver occlusive coils to aneurysms, include a detachable implant that is temporarily attached to a pusher mechanism within a microcatheter. The pusher mechanism is used to advance the implant out of the distal end of the microcatheter. Once the implant has been advanced to a desired location relative to the microcatheter, referred to herein as a detachment zone, a detachment mechanism is employed to detach the implant from the pusher. It is important not to detach the implant prior to

reaching the detachment zone as the implant may get hung up in the end of the catheter and subsequently get deployed at an undesirable location in the body.

Typically, in order to determine whether the implant has been advanced to the detachment zone relative to the microcatheter, radiopaque markers are used on both the microcatheter and either the pusher, the implant, or both. Thus, an operator uses the radiopaque markers to monitor the relative positions of the microcatheter and the implant as the implant is being advanced with the pusher. Monitoring the positions of the radiopaque markers requires the use of an x-ray device during the procedure. Using an x-ray imaging machine adds expense, complicates the procedure, and adds another space-consuming machine to the area surrounding the patient. Additionally, due to the coiled nature of the implant, the view of the radiopaque markers can become blocked by the coil.

SUMMARY OF THE INVENTION

The present invention is an implant delivery and detachment system used to position and deploy implantable devices such as coils, stents, filters, and the like within a body cavity including, but not limited to, blood vessels, fallopian tubes, malformations such as fistula and aneurysms, heart defects (e.g. left atrial appendages and septal openings), and other luminal organs.

The system comprises an implant, a delivery catheter (generically referred to as the pusher or delivery pusher), a detachable joint for coupling the implant to the pusher, a heat generating apparatus (generically referred to as the heater), and a power source to apply energy to the heater.

In one aspect of the present invention, the implant is coupled to the pusher using a tether, string, thread, wire, filament, fiber, or the like. Generically this is referred to as the tether. The tether may be in the form of a monofilament, rod, ribbon, hollow tube, or the like. Many materials can be used to detachably join the implant to the pusher. One class of materials are polymers such as polyolefin, polyolefin elastomer such as those made by Dow marketed under the trade name Engage or Exxon marketed under the trade name Affinity, polyethylene, polyester (PET), polyamide (Nylon), polyurethane, polypropylene, block copolymer such as PEBAX or Hytrel, and ethylene vinyl alcohol (EVA); or rubbery materials such as silicone, latex, and Kraton. In some cases, the polymer may also be cross-linked with radiation to manipulate its tensile strength and melt temperature. Another class of materials is metals such as nickel titanium alloy (Nitinol), gold, and steel. The selection of the material depends on the capacity of the material to store potential energy, the melting or softening temperature, the power used for detachment, and the body treatment site. The tether may be joined to the implant and/or the pusher by welding, knot tying, soldering, adhesive bonding, or other means known in the art. In one embodiment where the implant is a coil, the tether may run through the inside lumen of the coil and be attached to the distal end of the coil. This design not only joins the implant to the pusher, but also imparts stretch resistance to the coil without the use of a secondary stretch resistant member. In other embodiments where the implant is a coil, stent, or filter; the tether is attached to the proximal end of the implant.

In another aspect of the present invention, the tether detachably coupling the implant to the pusher acts as a reservoir of stored (i.e. potential) energy that is released during detachment. This advantageously lowers the time and energy required to detach the implant because it allows the

tether to be severed by application of heat without necessarily fully melting the material. The stored energy also may exert a force on the implant that pushes it away from the delivery catheter. This separation tends to make the system more reliable because it may prevent the tether from re-solidifying and holding the implant after detachment. Stored energy may be imparted in several ways. In one embodiment, a spring is disposed between the implant and pusher. The spring is compressed when the implant is attached to the pusher by joining one end of the tether to one of either the pusher or implant, pulling the free end of the tether until the spring is at least partially compressed, then affixing the free end of the tether to the other of the implant or the pusher. Since both ends of the tether are restrained, potential energy in the form of tension on the tether (or compression in the spring) is stored within the system. In another embodiment, one end of the tether is fixed as in the previous embodiment, and then the tether is placed in tension by pulling on the free end of the tether with a pre-determined force or displacement. When the free end of the tether is then affixed, the elongation (i.e. elastic deformation) of the tether material itself stores energy.

In another aspect of the present invention, a heater is disposed on or within the pusher, typically, but not necessarily, near the distal end of the pusher. The heater may be attached to the pusher by, for example, soldering, welding, adhesive bonding, mechanical bonding, or other techniques known in the art. The heater may be in the form of a wound coil, heat pipe, hollow tube, band, hypotube, solid bar, toroid, or similar shape. The heater may be made from a variety of materials such as steel, chromium cobalt alloy, platinum, silver, gold, tantalum, tungsten, manganin, chromium nickel alloy available from California Fine Wire Company under the trade name Stable Ohm, conductive polymer, or the like. The tether is disposed in proximity to the heater. The tether may pass through the lumen of a hollow or coil-type heater or may be wrapped around the heater. Although the tether may be disposed in direct contact with the heater, this is not necessary. For ease of assembly, the tether may be disposed in proximity to, but not actually touching, the heater.

The delivery catheter or pusher is an elongate member with distal and proximal ends adapted to allow the implant to be maneuvered to the treatment site. The pusher comprises a core mandrel and one or more electrical leads to supply power to the heater. The pusher may taper in dimension and/or stiffness along the length, with the distal end usually being more flexible than the proximal end. In one embodiment, the pusher is adapted to be telescopically disposed within a delivery conduit such as a guide catheter or microcatheter. In another embodiment, the pusher contains an inner lumen allowing it to be maneuvered over a guide wire. In still another embodiment, the pusher can be maneuvered directly to the treatment site without a secondary device. The pusher may have a radiopaque marking system visible with fluoroscopy that allows it to be used in conjunction with radiopaque markings on the microcatheter or other adjunctive devices.

In another aspect of the present invention, the core mandrel is in the form of a solid or hollow shaft, wire, tube, hypotube, coil, ribbon, or combination thereof. The core mandrel may be made from plastic materials such as PEEK, acrylic, polyamide, polyimide, Teflon, acrylic, polyester, block copolymer such as PEBAX, or the like. The plastic member(s) may be selectively stiffened along the length with reinforcing fibers or wires made from metal, glass, carbon fiber, braid, coils, or the like. Alternatively, or in

combination with plastic components, metallic materials such as stainless steel, tungsten, chromium cobalt alloy, silver, copper, gold, platinum, titanium, nickel titanium alloy (Nitinol), and the like may be used to form the core mandrel.

Alternatively, or in combination with plastic and/or metallic components, ceramic components such as glass, optical fiber, zirconium, or the like may be used to form the core mandrel. The core mandrel may also be a composite of materials. In one embodiment, the core mandrel comprises an inner core of radiopaque material such as platinum or tantalum and an outer covering of kink-resistant material such as steel or chromium cobalt. By selectively varying the thickness of the inner core, radiopaque identifiers can be provided on the pusher without using secondary markers. In another embodiment, a core material, for example stainless steel, with desirable material properties such as kink resistance and/or compressive strength is selectively covered (by, for example, plating, drawing, or similar methods known in the art) with a low electrical resistance material such as copper, aluminum, gold, or silver to enhance its electrical conductivity, thus allowing the core mandrel to be used as an electrical conductor. In another embodiment, a core material, for example, glass or optical fiber, with desirable properties such as compatibility with Magnetic Resonance Imaging (MRI), is covered with a plastic material such as PEBAX or polyimide to prevent the glass from fracturing or kinking.

In another aspect of the present invention, the heater is attached to the pusher, and then one or more electrical conductors are attached to the heater. In one embodiment a two of conductive wires run substantially the length of the pusher and are coupled to the heater near the distal end of the pusher and to electrical connectors near the proximal end of the pusher. In another embodiment, one conductive wire runs the substantially the length of the pusher and the core mandrel itself is made from a conductive material or coated with a conductive material to act as a second electrical lead. The wire and the mandrel are coupled to the heater near the distal end and to one or more connectors near the proximal end of the pusher. In another embodiment, a bipolar conductor is coupled to the heater and is used in conjunction with radiofrequency (RF) energy to power the heater. In any of the embodiments, the conductor(s) may run in parallel to the core mandrel or may pass through the inner lumen of a substantially hollow core mandrel (for example, a hypotube).

In another aspect of the present invention, an electrical and/or thermally insulating cover or sleeve may be placed over the heater. The sleeve may be made from insulating materials such as polyester (PET), Teflon, block copolymer, silicone, polyimide, polyamide, and the like.

In another aspect of the present invention, electrical connector(s) are disposed near the proximal end of the pusher so that the heater can be electrically connected to a power source through the conductors. In one embodiment, the connectors are in the form of a plug with one or more male or female pins. In another embodiment, the connector(s) are tubes, pins, or foil that can be connected with clip-type connectors. In another embodiment, the connector(s) are tubes, pins, or foil that are adapted to mate with an external power supply.

In another aspect of the present invention, the pusher connects to an external power source so that the heater is electrically coupled to the power source. The power source may be from battery(s) or connected to the electrical grid by a wall outlet. The power source supplies current in the form of direct current (DC), alternating current (AC), modulated

direct current, or radiofrequency (RF) at either high or low frequency. The power source may be a control box that operates outside of the sterile field or may be a hand-held device adapted to operate within a sterile field. The power source may be disposable, rechargeable, or may be reusable with disposable or rechargeable battery(s).

In another aspect of the present invention, the power source may comprise an electronic circuit that assists the user with detachment. In one embodiment, the circuit detects detachment of the implant and provides a signal to the user when detachment has occurred. In another embodiment, the circuit comprises a timer that provides a signal to the user when a pre-set length of time has elapsed. In another embodiment, the circuit monitors the number of detachments and provides a signal or performs an operation such as locking the system off when a pre-set number of detachments have been performed. In another embodiment, the circuit comprises a feedback loop that monitors the number of detachment attempts and increases the current, voltage, and/or detachment time in order to increase the likelihood of a successful detachment.

In another aspect of the present invention, the construction of the system allows for extremely short detachment time. In one embodiment the detachment time is less than 1 second.

In another aspect of the present invention, the construction of the system minimizes the surface temperature of the device during detachment. In one embodiment, the surface temperature at the heater during detachment is under 50° C. In another embodiment, the surface temperature at the heater during detachment is under 42° C.

The present invention is also a method and system for detecting the location of the detachment zone of a detachable coil as it exits the distal tip of the microcatheter without using radiopaque markers. Various sensing techniques are used to detect a change in various corresponding parameters due to the environmental difference between the inside of the microcatheter and exposure to a target site in the body.

In another aspect of the present invention a temperature sensor is utilized to detect a change in temperature as the sensor exits the microcatheter. The change in temperatures indicates that the detachable implant is in a desired detachment zone.

In another aspect of the present invention a pressure sensor is utilized to detect a change in pressure as the sensor exits the microcatheter. The change in pressure indicates that the detachable implant is in a desired detachment zone.

In another aspect of the present invention an ultrasound sensor is utilized to detect a change in environmental space as the sensor exits the microcatheter. When inside the microcatheter, the ultrasonic sensor detects the distance to the inner walls of the microcatheter. When outside the microcatheter, the ultrasonic sensor detects the increased distance to the inner walls of the vascular lumen or aneurysm. Hence, the change in distance indicates that the detachable implant is in a desired detachment zone.

Yet another aspect of the present invention the detachable coil is utilized as a detection mechanism. During navigation to the target site, the coil is contained, in a straight configuration, within the microcatheter. As the coil is pushed out of the microcatheter, it regains a curved configuration. If an electrical current is passed through the coil, the resistance to current flow through the coil changes as it curves. This change in resistance is used as a detection mechanism.

These and other aspects and features of the present invention will be appreciated upon consideration of the following drawings and detailed descriptions.

BRIEF DESCRIPTION OF THE DRAWINGS

FIG. 1 illustrates a cross-sectional side view of a first embodiment of a detachment system according to the present invention;

FIG. 2 illustrates a cross-sectional side view of a second embodiment of a detachment system according to the present invention;

FIG. 3A illustrates example direct signaling current according to the present invention;

FIG. 3B illustrates example alternating signaling current according to the present invention;

FIG. 4 illustrates a cross-sectional side view of a third embodiment of a detachment system according to the present invention;

FIG. 5 illustrates example temperature data of the surface of a detachment system as a function of time according to the present invention;

FIG. 6 illustrates a cross-sectional side view of an electrical connector of a detachment system according to the present invention;

FIG. 7 illustrates a cross-sectional side view of radiopaque layers of a detachment system according to the present invention; and

FIG. 8 illustrates a cross-sectional side view of a detachment system including a stent according to the present invention;

FIG. 9 illustrates a partially exploded perspective view of a delivery system according to the present invention;

FIG. 10 illustrates a cross-sectional side view of an electrical connector of a detachment system according to the present invention.

DETAILED DESCRIPTION OF THE INVENTION

Turning to FIG. 1, a detachment system **100** of the present invention, and specifically the distal portion of the detachment system **100**, is illustrated. The detachment system **100** includes a pusher **102** that is preferably flexible. The pusher **102** is configured for use in advancing an implant device **112** into and within the body of a patient and, specifically, into a target cavity site for implantation and delivery of the implant device **112**. Potential target cavity sites include but are not limited to blood vessels and vascular sites, such as, e.g., aneurysms and fistula, heart openings and defects, such as, e.g., the left atrial appendage, and other luminal organs, such as, e.g., fallopian tubes.

A stretch-resistant tether **104** detachably couples the implant **112** to the pusher **102**. In this example, the tether **104** is a plastic tube that is bonded to the pusher **102**. A substantially solid cylinder could also be a design choice for the tether **104**. The stretch resistant tether **104** extends at least partially through the interior lumen of an implant device **112**.

Near the distal end of the pusher **102**, a heater **106** is disposed in proximity to the stretch resistant tether **104**. The heater **106** may be wrapped around the stretch resistant tether **104** such that the heater **106** is exposed to or otherwise in direct contact with the blood or the environment, or alternatively may be insulated by a sleeve, jacket, epoxy, adhesive, or the like. The pusher **102** comprises a pair of electrical wires, positive electrical wire **108** and negative electrical wire **110**. The wires **108** and **110** are coupled to the heater **106** by any suitable means, such as, e.g., by welding or soldering.

The electrical wires **108**, **110** are capable of being coupled to a source of electrical power (not shown). As illustrated the negative electrical wire **110** is coupled to the distal end of the heater **106** and the positive electrical wire **108** is coupled to the proximal end of the heater **106**. In another embodiment, this configuration may be reversed, i.e., the negative electrical wire **110** is coupled to the proximal end of the heater **106** while the positive electrical wire **108** is coupled to the distal end of the heater **106**.

Energy is applied to the heater **106** from the electrical wires **108**, **110** in order to sever the portion of the tether **104** in the proximity of the heater **106**. It is not necessary for the heater **106** to be in direct contact with the tether **104**. The heater **106** merely should be in sufficient proximity to the tether **104** so that heat generated by the heater **106** causes the section of the stretch resistant tether **104** that is approximately distal from the heater **106** and within the lumen of an implant device **112** is released from the pusher **102** along with the implant device **112**.

As illustrated, the implant device **112** is an embolic coil. An embolic coil suitable for use as the implant device **112** may comprise a suitable length of wire formed into a helical microcoil. The coil may be formed from a biocompatible material including platinum, rhodium, palladium, rhenium, tungsten, gold, silver, tantalum, and various alloys of these metals, as well as various surgical grade stainless steels. Specific materials include the platinum/tungsten alloy known as Platinum 479 (92% Pt, 8% W, available from Sigmund Cohn, of Mount Vernon, N.Y.) and nickel/titanium alloys (such as the nickel/titanium alloy known as Nitinol).

Another material that may be advantageous for forming the coil is a bimetallic wire comprising a highly elastic metal with a highly radiopaque metal. Such a bimetallic wire would also be resistant to permanent deformation. An example of such a bimetallic wire is a product comprising a Nitinol outer layer and an inner core of pure reference grade platinum, available from Sigmund Cohn, of Mount Vernon, N.Y., and Anomet Products, of Shrewsbury, Mass.

Commonly-assigned U.S. Pat. No. 6,605,101 provides a further description of embolic coils suitable for use as the implant device **112**, including coils with primary and secondary configurations wherein the secondary configuration minimizes the degree of undesired compaction of the coil after deployment. The disclosure of U.S. Pat. No. 6,605,101 is fully incorporated herein by reference. Furthermore, the implant device **112** may optionally be coated or covered with a hydrogel or a bioactive coating known in the art.

The coil-type implant device **112** resists unwinding because the stretch resistant tether **104** that extends through the lumen of the implant device **112** requires substantially more force to plastically deform than the implant device **112** itself. The stretch resistant tether **104** therefore assists in preventing the implant device **112** from unwinding in situations in which the implant device **112** would otherwise unwind.

During assembly, potential energy may be stored within the device to facilitate detachment. In one embodiment, an optional spring **116** is placed between the heater **106** and the implant device **112**. The spring is compressed during assembly and the distal end of the tether **104** may be tied or coupled to the distal end of the implant device **112**, or may be melted or otherwise formed into an atraumatic distal end **114**.

In one embodiment, the stretch resistant tether **104** is made from a material such as a polyolefin elastomer, polyethylene, or polypropylene. One end of the tether **104** is

attached to the pusher **102** and the free end of the tether **104** is pulled through the implant **112** with the proximal end of the implant **112** flush to either the heater **106** (if no spring **116** is present) or to the compressed spring **116**. A pre-set force or displacement is used to pre-tension the tether **104**, thus storing energy in an axial orientation (i.e. co-linear or parallel to the long axis of the pusher **102**) within the tether **104**. The force or displacement depends on the tether material properties, the length of the tether **104** (which itself depends on the tether's attachment point on the pusher and the length of the implant). Generally, the force is below the elastic limit of the tether material, but sufficient to cause the tether to sever quickly when heat is applied. In one preferred embodiment wherein the implant to be deployed is a cerebral coil, the tether has a diameter within the range of approximately 0.001 to 0.007 inches. Of course the size of the tether can be changed to accommodate different types and sizes of other implants as necessary.

Turning to FIG. 2, another embodiment of a detachment system of the present invention, detachment system **200**, is illustrated. Detachment system **200** shares several common elements with detachment system **100**. For example, the same devices usable as the implant device **112** with detachment system **100** are also usable as the implant device **112** with detachment system **200**. These include, e.g., various embolic microcoils and coils. The implant device **112** has been previously described with respect to detachment system **100**. As with the implant device **112**, the same identification numbers are used to identify other elements/components of detachment system **100** that may correspond to elements/components of detachment system **200**. Reference is made to the description of these elements in the description of detachment system **100** as that description also applies to these common elements in detachment system **200**.

With detachment system **200**, an interior heating element **206** is used to separate a section of a stretch resistant tube **104** and an associated implant device **112** from the detachment system **200**. Detachment system **200** includes a delivery pusher **202** that incorporates a core mandrel **218**. The detachment system **200** further includes a positive electrical wire **208** and a negative electrical wire **210** that extend through the lumen of the delivery pusher **202**.

To form the internal heating element **206**, the positive electrical wire **208** and the negative electrical wire **210** may be coupled to the core mandrel **218** of the delivery pusher **202**. Preferably, the electrical wires **208**, **210** are coupled to a distal portion of the core mandrel **218**.

In one embodiment, the positive electrical wire **208** is coupled to a first distal location on the core wire **218**, and the negative electrical wire **210** is coupled to a second distal location on the core wire **218**, with the second distal location being proximal to the first distal location. In another embodiment, the configuration is reversed, i.e., the positive electrical wire **208** is coupled to the second distal location and the negative electrical wire **210** is coupled to the first distal location on the core wire **218**. When the positive electrical wire **208** and the negative electrical wire **210** are coupled to the distal portion of the core mandrel **218**, the distal portion of the core mandrel **218** along with the electrical wires **208**, **210** forms a circuit that is the interior heating element **206**.

The heater **206** increases in temperature when a current is applied from a power source (not shown) that is coupled to the positive electrical wire **208** and the negative electrical wire **210**. If a greater increase in temperature/higher degree of heat is required or desired, a relatively high resistance material such as platinum or tungsten may be coupled to the

distal end of the core mandrel **218** to increase the resistance of the core mandrel **218**. As a result, higher temperature increases are produced when a current is applied to the heater **206** than would be produced with a lower resistance material. The additional relatively high resistance material coupled to the distal end of the core mandrel **218** may take any suitable form, such as, e.g., a solid wire, a coil, or any other shape or material as described above.

Because the heater **206** is located within the lumen of the tube-shaped tether **104**, the heater **206** is insulated from the body of the patient. As a result, the possibility of inadvertent damage to the surrounding body tissue due to the heating of the heater **206** may be reduced.

When a current is applied to the heater **206** formed by the core mandrel **218**, the positive electrical wire **208**, and the negative electrical wire **210**, the heater **206** increases in temperature. As a result, the portion of the stretch resistant tether **104** in proximity to the heater **206** severs and is detached, along with the implant device **112** that is coupled to the tether **104**, from the detachment system **200**.

In one embodiment of the detachment system **200**, the proximal end of the stretch resistant tether **104** (or the distal end of a larger tube (not shown) coupled to the proximal end of the stretch resistant tether **104**) may be flared in order to address size constraints and facilitate the assembly of the detachment system **200**.

In a similar manner as with detachment system **100**, energy may be stored within the system with, for example, an optional compressive spring **116** or by pre-tensioning the tether **104** during assembly as previously described. When present, the release of potential energy stored in the system operates to apply additional pressure to separate the implant device **112**, and the portion of the stretch resistant tether **104** to which the implant device **112** is coupled, away from the heater **206** when the implant device **112** is deployed. This advantageously lowers the required detachment time and temperature by causing the tether **104** to sever and break.

As with detachment system **100**, the distal end of the stretch resistant tether **104** of detachment system **200** may be tied or coupled to the distal end of the implant device **112**, or may be melted or otherwise formed into an atraumatic distal end **114**.

FIG. 4 illustrates another preferred embodiment of a detachment system **300**. In many respects, the detachment system **300** is similar to the detachment system **200** shown in FIG. 2 and detachment system **100** shown in FIG. 1. For example, the detachment system **300** includes a delivery pusher **301** containing a heater **306** that detaches an implant device **302**. Detachment system **300** also utilizes a tether **310** to couple the implant device **302** to the delivery pusher **301**.

In the cross-sectional view of FIG. 4, a distal end of the delivery pusher **301** is seen to have a coil-shaped heater **306** that is electrically coupled to electrical wires **308** and **309**. These wires **308**, **309** are disposed within the delivery pusher **301**, exiting at a proximal end of the delivery pusher **301** and coupling to a power supply (not shown). The tether **310** is disposed in proximity to the heater **306**, having a proximal end fixed within the delivery pusher **301** and a distal end coupled to the implant device **302**. As current is applied through wires **308** and **309**, the heater **306** increases in temperature until the tether **310** breaks, releasing the implant device **302**.

To reduce the transfer of heat from the heater **306** to the surrounding tissue of the patient and to provide electrical insulation, an insulating cover **304** is included around at least the distal end of the outer surface of the delivery pusher **301**. As the thickness of the cover **304** increases, the thermal

insulating properties also increase. However, increased thickness also brings increased stiffness and a greater diameter to the delivery pusher **301** that could increase the difficulty of performing a delivery procedure. Thus, the cover **304** is designed with a thickness that provides sufficient thermal insulating properties without overly increasing its stiffness.

To enhance attachment of the tether **310** to the implant device **302**, the implant device **302** may include a collar member **322** welded to the implant device **302** at weld **318** and sized to fit within the outer reinforced circumference **312** of the delivery pusher **301**. The tether **310** ties around the proximal end of the implant device **302** to form knot **316**. Further reinforcement is provided by an adhesive **314** that is disposed around the knot **316** to prevent untying or otherwise unwanted decoupling.

In a similar manner as with detachment systems **100** and **200**, energy may be stored within the system with, for example, an optional compressive spring (similar to compressive spring **116** in FIG. 1 but not shown in FIG. 4) or by axially pre-tensioning the tether **104** during assembly. In this embodiment, one end of the tether **310** is attached near the proximal end of the implant device **302** as previously described. The free end of the tether **310** is threaded through a distal portion of the delivery pusher **301** until it reaches an exit point (not shown) of the delivery pusher **301**. Tension is applied to the tether **310** in order to store energy in the form of elastic deformation within the tether material by, for example, placing a pre-determined force on the free end of the tether **310** or moving the taunt tether **310** a pre-determined displacement. The free end of the tether **310** is then joined to the delivery pusher **301** by, for example, tying a knot, applying adhesive, or similar methods known in the art.

When present, the release of potential energy stored in the system operates to apply additional pressure to separate the implant device **302**, and the portion of the tether **310** to which the implant device **302** is coupled, away from the heater **306** when the implant device **302** is deployed. This advantageously lowers the required detachment time and temperature by causing the tether **310** to sever and break.

The present invention also provides for methods of using detachment systems such as detachment systems **100**, **200**, or **300**. The following example relates to the use of detachment system **100**, **200**, or **300** for occluding cerebral aneurysms. It will, however, be appreciated that modifying the dimensions of the detachment system **100**, **200**, or **300** and the component parts thereof and/or modifying the implant device **112**, **302** configuration will allow the detachment system **100**, **200**, or **300** to be used to treat a variety of other malformations within a body.

With this particular example, the delivery pusher **102**, **202**, or **301** of the detachment system **100**, **200**, or **300** may be approximately 0.010 inches to 0.030 inches in diameter. The tether **104**, **310** that is coupled near the distal end of the delivery pusher **102**, **202**, or **301** and is coupled the implant device **112**, **302** may be 0.0002 inches to 0.020 inches in diameter. The implant device **112**, **302**; which may be a coil, may be approximately 0.005 inches to 0.020 inches in diameter and may be wound from 0.0005 inch to 0.005 inch wire.

If potential energy is stored within the detachment system **100**, **200**, or **300**, the force used to separate the implant **112**, **302** from the pusher typically ranges up to 250 grams force.

The delivery pusher **102**, **202**, or **301** may comprise a core mandrel **218** and at least one electrically conductive wire **108**, **110**, **208**, **210**, **308**, or **309**. The core mandrel **218** may

be used as an electrical conductor, or a pair of conductive wires may be used, or a bipolar wire may be used as previously described.

Although the detachment systems **100**, **200**, and **300** have been illustrated as delivering a coil, other implant devices are contemplated in the present invention. For example, FIG. **8** illustrates the detachment system **300** as previously described in FIG. **4** having an implant that is a stent **390**. This stent **390** could similarly be detached by a similar method as previously described in regards to the detachment systems **100**, **200**, and **300**. In a further example, the detachment systems **100**, **200**, or **300** may be used to deliver a filter, mesh, scaffolding or other medical implant suitable for delivery within a patient.

FIG. **7** presents an embodiment of a delivery pusher **350**, which could be used in any of the embodiments as delivery pusher **102**, **202**, or **301**, which includes radiopaque materials to communicate the position of the delivery pusher **350** to the user. Specifically, the radiopaque marker material is integrated into the delivery pusher **350** and varied in thickness at a desired location, facilitating easier and more precise manufacturing of the final delivery pusher **350**.

Prior delivery pusher designs, such as those seen in U.S. Pat. No. 5,895,385 to Guglielmi, herein incorporated by reference, rely on high-density material such as gold, tantalum, tungsten, or platinum in the form of an annular band or coil. The radiopaque marker is then bonded to other, less dense materials, such as stainless steel, to differentiate the radiopaque section. Since the radiopaque marker is a separate element placed at a specified distance (often about 3 cm) from the tip of the delivery pusher, the placement must be exact or the distal tip of the delivery pusher **350** can result in damage to the aneurysm or other complications. For example, the delivery pusher **350** may be overextended from the microcatheter to puncture an aneurysm. Additionally, the manufacturing process to make a prior delivery pusher can be difficult and expensive, especially when bonding dissimilar materials.

The radiopaque system of the present invention overcomes these disadvantages by integrating a first radiopaque material into most of the delivery pusher **350** while varying the thickness of a second radiopaque material, thus eliminating the need to bond multiple sections together. As seen in FIG. **7**, the delivery pusher **350** comprises a core mandrel **354** (i.e. the first radiopaque material), preferably made from radiopaque material such as tungsten, tantalum, platinum, or gold (as opposed to the mostly radiolucent materials of the prior art designs such as steel, Nitinol, and Elgiloy).

The delivery pusher **350** also includes a second, outer layer **352**, having a different radiopaque level. Preferably, outer layer **352** is composed of a material having a lower radiopaque value than the core mandrel **354**, such as Elgiloy, Nitinol, or stainless steel (commercially available from Fort Wayne Metals under the trade name DFT). In this respect, both the core mandrel **354** and the outer layer **352** are visible and distinguishable from each other under fluoroscopy. The outer layer **352** varies in thickness along the length of the delivery pusher **350** to provide increased flexibility and differentiation in radio-density. Thus the thicker regions of the outer layer **352** are more apparent to the user than the thinner regions under fluoroscopy.

The transitions in thickness of the outer layer **352** can be precisely created at desired locations with automated processes such as grinding, drawing, or forging. Such automated processes eliminate the need for hand measuring and placement of markers and further eliminates the need to

bond a separate marker element to other radiolucent sections, thus reducing the manufacturing cost and complexity of the system.

In the present embodiment, the delivery pusher **350** includes three main indicator regions of the outer layer **352**. A proximal region **356** is the longest of the three at 137 cm, while a middle region **358** is 10 cm and a distal region **360** is 3 cm. The length of each region can be determined based on the use of the delivery pusher **350**. For example, the 3 cm distal region **360** may be used during a coil implant procedure, as known in the art, allowing the user to align the proximal edge of the distal region **360** with a radiopaque marker on the microcatheter within which the delivery pusher **350** is positioned. The diameter of each of the regions depends on the application and size of the implant. For a typical cerebral aneurysm application for example, the proximal region **356** may typically measure 0.005-0.015 inches, the middle region **358** may typically measure 0.001-0.008 inches, while the distal region **360** may typically measure 0.0005-0.010 inches. The core mandrel **354** will typically comprise between about 10-80% of the total diameter of the delivery pusher **350** at any point.

Alternately, the delivery pusher **350** may include any number of different regions greater than or less than the three shown in FIG. **7**. Additionally, the radiopaque material of the core mandrel **354** may only extend partially through the delivery pusher **350**. For example, the radiopaque material could extend from the proximal end of the core mandrel **354** to three centimeters from the distal end of the delivery pusher **350**, providing yet another predetermined position marker visible under fluoroscopy.

In this respect, the regions **356**, **358**, and **360** of delivery pusher **350** provide a more precise radiopaque marking system that is easily manufactured, yet is readily apparent under fluoroscopy. Further, the increased precision of the markers may decrease complications relating to improper positioning of the delivery pusher during a procedure.

In operation, the microcatheter is positioned within a patient so that a distal end of the microcatheter is near a target area or lumen. The delivery pusher **350** is inserted into the proximal end of the microcatheter and the core mandrel **354** and outer layer **352** are viewed under fluoroscopy. The user aligns a radiopaque marker on the microcatheter with the beginning of the distal region **360**, which communicates the location of the implant **112**, **302** relative to the tip of the microcatheter.

In some situations, for example, small aneurysms where there may be an elevated risk of vessel damage from the stiffness of the delivery pusher **350**, the user may position the proximal end of the implant slightly within the distal end of the microcatheter during detachment. The user then may push the proximal end of the implant **112**, **302** out of the microcatheter with the next coil, an adjunctive device such as guidewire, or the delivery pusher **102**, **202**, **301**, or **350**. In another embodiment, the user may use the radiopaque marking system to locate the distal end of the delivery pusher outside the distal end of the microcatheter.

Once the implant device **112**, **302** of the detachment system **100**, **200**, or **300** is placed in or around the target site, the operator may repeatedly reposition the implant device **112**, **302** as necessary or desired.

When detachment of the implant device **112**, **302** at the target site is desired, the operator applies energy to the heater **106**, **206**, or **306** by way of the electrical wires **108**, **110**, **208**, **210**, **308**, or **309**. The electrical power source for the energy may be any suitable source, such as, e.g., a wall outlet, a capacitor, a battery, and the like. For one aspect of this

method, electricity with a potential of approximately 1 volt to 100 volts is used to generate a current of 1 milliamp to 5000 milliamps, depending on the resistance of the detachment system 100, 200, or 300.

One embodiment of a connector system 400 that can be used to electrically couple the detachment system 100, 200, or 300 to the power source is shown in FIG. 6. The connector system 400 includes an electrically conductive core mandrel 412 having a proximal end surrounded by an insulating layer 404. Preferably the insulating layer 404 is an insulating sleeve such as a plastic shrink tube of polyolefin, PET, Nylon, PEEK, Teflon, or polyimide. The insulating layer 404 may also be a coating such as polyurethane, silicone, Teflon, paralyene. An electrically conductive band 406 is disposed on top of the insulating layer 404 and secured in place by molding bands 414, adhesive, or epoxy. Thus, the core mandrel 412 and the conductive band 406 are electrically insulated from each other. The conductive band 406 is preferably composed of any electrically conductive material, such as silver, gold, platinum, steel, copper, conductive polymer, conductive adhesive, or similar materials, and can be a band, coil, or foil. Gold is especially preferred as the conductive material of the conductive band 406 because of the ability of gold to be drawn into a thin wall and its ready availability. The core mandrel 412 has been previously described and may be plated with, for example, gold, silver, copper, or aluminum to enhance its electrical conductivity.

The connector system 400 also includes two electrical wires 408 and 410 which connect to the conductive band 406 and core member 412, respectively, and to a heating element at the distal end of a delivery system such as those described in FIGS. 1, 2, and 4 (not shown in FIG. 6). These wires 408 and 410 are preferably connected by soldering, brazing, welding, laser bonding, or conductive adhesive, or similar techniques.

Once the user is ready to release the implant 112, 302 within the patient, a first electrical clip or connector from a power source is connected to a non-insulated section 402 of the core mandrel 412 and a second electrical clip or connector from the power source is connected to the conductive band 406. Electrical power is applied to the first and second electrical clips, forming an electrical circuit within the detachment system 100, 200, or 300, causing the heater 106, 206, or 306 to increase in temperature and sever the tether 104, 310.

Once the detachment system 100, 200, or 300 is connected to the power source the user may apply a voltage or current as previously described. This causes the heater 106, 206, or 306 to increase in temperature. When heated, the pre-tensioned tether 104, 310 will tend to recover to its unstressed (shorter) length due to heat-induced creep. In this respect, when the tether 104, 310 is heated by the heater 106, 206, or 306; its overall size shrinks. However, since each end of the tether 104, 310 is fixed in place as previously described, the tether 104, 310 is unable to shorten in length, ultimately breaking to release the implant device 112, 302.

Because there is tension already within the system in the form of a spring 116 or deformation of the tether material 104, 310; the amount of shrinkage required to break the tether 104, 310 is less than that of a system without a pre-tensioned tether. Thus, the temperature and time required to free the implant device 112, 302 is lower.

FIG. 5 is a graph showing the relationship between the temperature at the surface of PET cover 304 of the detachment system 300 and the time duration in which the heater coil 306 is activated. As can be seen, the surface temperature of the detachment system 300 during detachment does not

vary linearly with time. Specifically, it takes just under 1 second for the heat generated by the heating coil 306 to penetrate the insulating cover 304. After 1 second, the surface temperature of the insulating cover 304 dramatically increases. Although different outer insulating material may slightly increase or decrease this 1-second surface temperature window, the necessarily small diameter of the detachment system 100, 200, or 300 prevents providing a thick insulating layer that may more significantly delay a surface temperature increase.

It should be understood that the embodiments of the detachment system 100, 200, or 300 include a variety of possible constructions. For example, the insulating cover 304 may be composed of Teflon, PET, polyamide, polyimide, silicone, polyurethane, PEEK, or materials with similar characteristics. In the embodiments 100, 200, or 300 the typical thickness of the insulating cover is 0.0001-0.040 inches. This thickness will tend to increase when the device is adapted for use in, for example, proximal malformations, and decrease when the device is adapted for use in more distal, tortuous locations such as, for example, cerebral aneurysms.

In order to minimize the damage and possible complications caused by such a surface temperature increase, the present invention detaches the implant device 112, 302 before the surface temperature begins to significantly increase. Preferably, the implant device 112, 302 is detached in less than a second, and more preferably, in less than 0.75 seconds. This prevents the surface temperature from exceeding 50° C. (122° F.), and more preferably, from exceeding 42° C. (107° F.).

Once the user attempts to detach the implant device 112, 302, it is often necessary to confirm that the detachment has been successful. The circuitry integrated into the power source may be used to determine whether or not the detachment has been successful. In one embodiment of the present invention an initial signaling current is provided prior to applying a detachment current (i.e. current to activate the heater 106, 206, or 306 to detach an implant 112, 302). The signaling current is used to determine the inductance in the system before the user attempts to detach the implant and therefore has a lower value than the detachment current, so as not to cause premature detachment. After an attempted detachment, a similar signaling current is used to determine a second inductance value that is compared to the initial inductance value. A substantial difference between the initial inductance and the second inductance value indicates that the implant 112, 302 has successfully been detached, while the absence of such a difference indicates unsuccessful detachment. In this respect, the user can easily determine if the implant 112, 302 has been detached, even for delivery systems that utilize nonconductive temperature sensitive polymers to attach an implant, such as those seen in FIGS. 1, 2, and 4.

In the following description and examples, the terms "current" and "electrical current" are used in the most general sense and are understood to encompass alternating current (AC), direct current (DC), and radiofrequency current (RF) unless otherwise noted. The term "changing" is defined as any change in current with a frequency above zero, including both high frequency and low frequency. When a value is measured, calculated and/or saved, it is understood that this may be done either manually or by any known electronic method including, but not limited to, an electronic circuit, semiconductor, EPROM, computer chip, computer memory such as RAM, ROM, or flash; and the like. Finally, wire windings and toroid shapes carry a broad

meaning and include a variety of geometries such as circular, elliptical, spherical, quadrilateral, triangular, and trapezoidal shapes.

When a changing current passes through such objects as wire windings or a toroid, it sets up a magnetic field. As the current increases or decreases, the magnetic field strength increase or decreases in the same way. This fluctuation of the magnetic field causes an effect known as inductance, which tends to oppose any further change in current. Inductance (L) in a coil wound around a core is dependant on the number of turns (N), the cross-sectional area of the core (A), the magnetic permeability of the core (μ), and length of the coil (l) according to equation 1 below:

$$L = \frac{0.4\pi N^2 A\mu}{l} \quad \text{Equation 1.}$$

The heater **106** or **306** is formed from a wound coil with proximal and distal electrically conductive wires **108**, **110**, **308**, or **309** attached to a power source. The tether **104**, **310** has a magnetic permeability μ_1 and is positioned through the center of the resistive heater, having a length l, cross sectional area A, and N winds, forming a core as described in the previous equation. Prior to detachment, a changing signaling current i_1 , such as the waveforms shown in FIGS. **3A** and **3B**, with frequency f_1 , is sent through the coil windings. This signaling current is generally insufficient to detach the implant. Based on the signaling current, the inductive resistance X_L (i.e. the electrical resistance due to the inductance within the system) is measured by an electronic circuit such as an ohmmeter. The initial inductance of the system L_1 is then calculated according to the formula:

$$L_1 = \frac{X_L}{2\pi f_1} \quad \text{Equation 2.}$$

This initial value of the inductance L_1 depends on the magnetic permeability μ_1 of the core of the tether **104**, **310** according to Equation 1, and is saved for reference. When detachment is desired, a higher current and/or a current with a different frequency than the signaling current is applied through the resistive heater coil, causing the tether **104**, **310** to release the implant **112**, **302** as previously described. If detachment is successful, the tether **104**, **310** will no longer be present within the heater **106**, **306** and the inside of the heater **106**, **306** will fill with another material such as the patient's blood, contrast media, saline solution, or air. This material now within the heater core will have a magnetic permeability μ_2 that is different than the tether core magnetic permeability μ_1 .

A second signaling current and frequency f_2 is sent through the heater **106**, **306** and is preferably the same as the first signaling current and frequency, although one or both may be different without affecting the operation of the system. Based on the second signaling current, a second inductance L_2 is calculated. If the detachment was successful, the second inductance L_2 will be different (higher or lower) than the first inductance L_1 due to the difference in the core magnetic permeabilities μ_1 and μ_2 . If the detachment was unsuccessful, the inductance values should remain relatively similar (with some tolerance for measurement error). Once detachment has been confirmed by comparing the difference between the two inductances, an alarm or

signal can be activated to communicate successful detachment to the user. For example, the alarm might include a beep or an indicator light.

Preferably, the delivery system **100**, **300** used according to this invention connects to a device that automatically measures inductance at desired times, performs required calculations, and signals to the user when the implant device has detached from the delivery catheter. However, it should be understood that part or all of these steps can be manually performed to achieve the same result.

The inductance between the attached and detached states can also preferably be determined without directly calculating the inductance. For example, the inductive resistance X_L can be measured and compared before and after detachment.

In another example, the detachment can be determined by measuring and comparing the time constant of the system, which is the time required for the current to reach a predetermined percentage of its nominal value. Since the time constant depends on the inductance, a change in the time constant would similarly indicate a change in inductance.

The present invention may also include a feedback algorithm that is used in conjunction with the detachment detection described above. For example, the algorithm automatically increases the detachment voltage or current automatically after the prior attempt fails to detach the implant device. This cycle of measurement, attempted detachment, measurement, and increased detachment voltage/current continues until detachment is detected or a predetermined current or voltage limit is attained. In this respect, a low power detachment could be first attempted, followed automatically by increased power or time until detachment has occurred. Thus, battery life for a mechanism providing the detachment power is increased while the average coil detachment time is greatly reduced.

Referring now to FIGS. **9** and **10**, there is shown an embodiment of an implant delivery system **500** of the present invention. The implant delivery system **500** and connector system **501** are generally similar to the delivery pusher **301** and connector system **400**, respectively, previously described in this application and shown in FIGS. **4** and **6**. However, the implant delivery system **500** preferably includes a sensor **502** for detecting when the implant device **302** has been advanced out of a microcatheter **506** to a desired detachment location.

Generally, detachment of the implant device **302** is preferred once the implant device **302** has fully exited the microcatheter **506**. In this respect, the sensor **502** is positioned proximal to the implant device **302** on the pusher **301**. The sensor **502** detects a change in its environment (i.e., from a location within the microcatheter **506** to a location outside the microcatheter **506**, within vasculature of a patient) which is conveyed along wires **504** to the connector system **501** and ultimately to a human interface or display device (not shown) near the user. Preferably, the human interface may include a meter, electronic display, audible tone, or the like.

In yet another preferred embodiment not shown in the figures, the implant device **302** is utilized as a detection mechanism instead of or in addition to the sensor **502**. During navigation of the pusher **500** to the target deployment site within the vasculature, the pusher **500** remains within the microcatheter **506** and the coil of the implant device **302** remains relatively straight, as it is confined by the walls defining the internal lumen of the microcatheter **506**. When the implant assembly is deployed, the coil of the implant device **302** returns to a curved configuration. The

relative resistance of the coil of the implant device 302 from its distal end to its proximal end changes as the coil changes from a straight to a coiled configuration. Thus, the change in resistance can be used as a location detection mechanism.

In one preferred embodiment, the sensor 502 may be a temperature sensor, detecting the temperature differential (e.g., a change from a normal or unbiased state) between the inside and outside of the microcatheter 506. Due to the relatively short period of time during which the microcatheter 506 is disposed within the vasculature, the internal temperature of the microcatheter 506 is typically cooler than the temperature of the vasculature. Hence, the temperature increases markedly as the sensor 502 reaches the detachment zone (i.e., a position of preferred detachment) just outside the microcatheter 506. This jump in temperature is thus used as an indication that the detachment zone has been reached during the advancement of the implant device 302.

In another preferred embodiment, the sensor 502 is a pressure sensor for detecting a pressure differential (e.g., a change from a normal or unbiased state) inside and outside of the microcatheter 506. The pressure inside the microcatheter 506 is relatively constant, whereas the pressure outside the microcatheter 506 varies with systole and diastole of the blood stream. Hence, the sudden change of pressure from a relatively static reading to a dynamic reading can be used as an indication that the implant device 302 has been advanced to the detachment zone.

In another preferred embodiment, the sensor 502 includes both an ultrasound transceiver and sensor for detecting an ultrasound differential (e.g., a change from a normal or unbiased state) between an inside and outside of the microcatheter 506. The ultrasonic transceiver sends ultrasonic waves and receives echoes of the waves in order to determine distances to objects surrounding the transceiver. The walls of the microcatheter are much closer to the transceiver than the walls of the vasculature. Hence, the sudden increase in distance measured by the transceiver can be used as an indication that the implant device 302 has been advanced to the desired detachment zone.

Other sensors capable of detecting differential characteristics between an inside and outside of a microcatheter 506 may also be used.

In another preferred embodiment, the heater coil 306 may serve as a sensor instead of or in addition to sensor 502. A resistance differential (e.g., a change from a normal or unbiased state) of the heater coil 306 may be measured as it is advanced through the microcatheter 506. As the heater coil 502 exits the microcatheter 506, the environment surrounding the heater coil changes from dry and relatively cool, to the warm blood filled environment of the vasculature. This change in environment affects the resistance of the heater coil 306 to a measurable degree. The following example is provided to show data obtained using the heater coil 306 as a sensor:

EXAMPLES

A series of experiments were conducted to determine the resistance change of heater coils as they are advanced through a microcatheter. The procedure used in order to obtain the data was as follows:

1. Obtain coil pusher
2. Prepare flow model.
3. Measure and record coil resistance on gold connector.
4. Advance coil pusher into microcatheter slightly beyond hub at proximal end.

5. Measure and record coil resistance. Mark data as 0% pusher length.

6. Advance coil pusher roughly 50% of entire length. Measure and record coil resistance. Mark data as 50% pusher length.

7. Repeat step 6 for 75% and 100% of pusher length, 100% being defined as the detachment zone exiting the distal end of the microcatheter.

8. Retract pusher and stop at above steps (75%, 50%, and 0%) and measure and record data.

9. Repeat cycle 3 times.

10. Measure and record coil pusher resistance one last time in air, outside of the microcatheter.

11. Detach implant and record results.

The following data were collected using various catheter types and heater coil materials. All resistance values shown in Tables 1-3 are in Ohms. Blank values indicate no data was obtained. Percent pusher length is defined as percentage of the pusher inserted into microcatheter, e.g. 100 percent equals detachment coil exited from distal end of microcatheter. Resistance was measured from gold connectors at proximal end of pusher.

As a result of this data, a conclusion was drawn that of the two heater coil materials tested, namely Stablohm and platinum, Stablohm had a coefficient of thermal resistivity that is much higher than that of the platinum. Other materials with a higher coefficient of thermal resistivity may be used to provide a higher sensitivity of the reading instrument. Moreover, the data show that there is a difference in the advancing coil resistance of approximately 0.5 ohm for the platinum coil and 0.4 ohm for the stablohm (from 75%-100% mark).

Example 1

The microcatheter used for Example 1 was a Rapid Transit microcatheter. The heater coil material used was Stablohm 710. The flow temperature was 99 degrees F. The heater coil resistance before testing was 42.1 Ohm. The heater coil resistance after the test was not recorded. Table 1 shows the results of Example 1.

TABLE 1

Percent Pusher Length	Advance Resistance 1	Advance Resistance 2	Retract Resistance 1
0	42.1	42.1	42.1
50	42.2	—	42.2
75	42.5	42.5	—
100	42.6	42.6	42.6

Example 2

The microcatheter used for Example 2 was an Excelsior 1018 microcatheter. The heater coil material used was Platinum. The flow temperature was 98.7 degrees F. The heater coil resistance before testing was 40.9 Ohm, and the heater coil resistance after the test was 40.9 Ohm. Table 2 shows the results of Example 2.

TABLE 2

Percent Pusher Length	Advance Resistance 1	Advance Resistance 2	Advance Resistance 3	Retract Resistance 1	Retract Resistance 2	Retract Resistance 3
0	40.8	41.0	41.0	41.0	41.0	41.0
50	40.9	41.2	41.1	41.1	41.1	41.1
75	41.2	—	41.3	—	—	41.2
100	41.7	41.6	41.6	41.7	41.6	41.6

Example 3

The microcatheter used for Example 3 was an Excelsior SL10 microcatheter. The heater coil material used was Platinum. The flow temperature was 98.6 degrees F. The heater coil resistance before testing was 40.8 Ohm, and the heater coil resistance after the test was 40.7 Ohm. Table 3 shows the results of Example 3.

TABLE 3

Percent Pusher Length	Advance Resistance 1	Advance Resistance 2	Advance Resistance 3	Retract Resistance 1	Retract Resistance 2	Retract Resistance 3
0	40.8	40.9	40.8	40.9	40.8	40.7
50	41.0	41.0	41.0	41.0	40.9	41.0
75	41.1	41.2	41.2	41.2	41.1	41.2
100	41.6	41.6	41.7	41.6	41.6	41.7

Although the invention has been described in terms of particular embodiments and applications, one of ordinary skill in the art, in light of this teaching, can generate additional embodiments and modifications without departing from the spirit of or exceeding the scope of the claimed invention. Accordingly, it is to be understood that the drawings and descriptions herein are proffered by way of example to facilitate comprehension of the invention and should not be construed to limit the scope thereof.

What is claimed is:

1. A method for determining when an implant has advanced out of a microcatheter, the method comprising the steps of:

advancing an implant through a lumen of a microcatheter; obtaining with a sensor system resistance measurements from a resistance-type heater coil located in the microcatheter;

prior to detachment of the implant from the pusher within the microcatheter, monitoring the resistance measurements for a change in resistance due to blood entering the microcatheter when the implant has advanced out of the microcatheter; and

signaling that the implant has advanced out of the microcatheter based on the change in resistance prior to detachment of the implant from the pusher.

2. The method of claim 1, further comprising the step of communicating when the implant has advanced out of a microcatheter to a human interface device.

3. The method of claim 1, wherein the sensor system is calibrated to determine a resistance change of the resistance-type heater coil when the heater coil has distally advance about 75% or more of a length of the microcatheter.

4. A method of deploying an implant from a pusher, the method comprising the steps of:

advancing an implant through a lumen of a microcatheter; obtaining with a sensor system resistance measurements from a resistance-type heater coil connected to the pusher and located in the microcatheter;

prior to separation of the implant from the pusher, monitoring the resistance measurements for a change in resistance due to blood entering the microcatheter when the implant has advanced out of the microcatheter;

signaling that the implant has advanced out of the microcatheter based on the change in resistance prior to separation of the implant from the pusher; and separating the implant from the pusher based on said monitoring.

5. The method of claim 4, wherein the step of separating the implant from the pusher based on said monitoring comprises breaking a tether coupling the implant to the pusher.

6. The method of claim 4, wherein the sensor system is calibrated to determine a resistance change of the resistance-type heater coil when the heater coil has distally advance about 75% or more of a length of the microcatheter.

专利名称(译)	用于定位可拆卸植入物的分离区的系统和方法		
公开(公告)号	US10299755	公开(公告)日	2019-05-28
申请号	US14/975224	申请日	2015-12-18
[标]申请(专利权)人(译)	微温森公司		
申请(专利权)人(译)	MicroVention公司, INC.		
当前申请(专利权)人(译)	MicroVention公司, INC.		
[标]发明人	TIEU TAI D		
发明人	TIEU, TAI D.		
IPC分类号	A61B5/00 A61M25/01 A61F2/95 A61M25/00 A61B17/12 A61B8/08 A61F2/966 A61M25/06 A61F2/30 A61B34/20 A61B17/00		
CPC分类号	A61B8/0841 A61B17/12022 A61B17/12109 A61B17/12113 A61B17/12122 A61B17/12154 A61F2/95 A61F2/966 A61M25/0082 A61M25/0108 A61B17/1214 A61M2205/3653 A61B2017/00292 A61B2017/12068 A61B2034/2053 A61B2562/0247 A61B2562/0257 A61B2562/0271 A61F2002/30668 A61F2002/9505 A61F2250/0001 A61M25/0068 A61M2025/0042 A61M2025/0681 A61M2205/3331 A61M2205/3368 A61M2205/3375		
优先权	61/016154 2007-12-21 US		
其他公开文献	US20160100819A1		
外部链接	Espacenet		

摘要(译)

一种用于快速分离植入物和用于定位可拆卸植入物的分离区的系统和方法。当传感器从微导管内传递到暴露于脉管系统时，传感器确定局部环境的突然变化。传感器可以是温度传感器，超声波传感器，压力传感器等。如果可拆卸植入物组件使用加热器线圈来分离植入物，则加热器线圈可以用作传感器。另外，如果当植入物离开微导管并改变形状时可检测到电阻的变化，则植入物本身可用作传感器。

