



US009763598B2

(12) **United States Patent**
Ritchey et al.

(10) **Patent No.:** **US 9,763,598 B2**
(45) **Date of Patent:** **Sep. 19, 2017**

(54) **SYSTEM AND METHOD FOR IDENTIFYING A LANDMARK**

(71) Applicant: **Smith & Nephew, Inc.**, Memphis, TN (US)

(72) Inventors: **Nicholas S. Ritchey**, Collierville, TN (US); **Hoa La Wilhelm**, Arlington, TN (US); **Nathaniel Kelley Grusin**, Germantown, TN (US)

(73) Assignee: **Smith & Nephew, Inc.**, Memphis, TN (US)

(*) Notice: Subject to any disclaimer, the term of this patent is extended or adjusted under 35 U.S.C. 154(b) by 128 days.

(21) Appl. No.: **14/937,454**

(22) Filed: **Nov. 10, 2015**

(65) **Prior Publication Data**

US 2016/0058321 A1 Mar. 3, 2016

Related U.S. Application Data

(60) Continuation of application No. 14/580,579, filed on Dec. 23, 2014, now Pat. No. 9,192,399, which is a (Continued)

(51) **Int. Cl.**
A61B 5/06 (2006.01)
A61B 19/00 (2006.01)
(Continued)

(52) **U.S. Cl.**
CPC **A61B 5/061** (2013.01); **A61B 5/05** (2013.01); **A61B 5/06** (2013.01); **A61B 5/1127** (2013.01);
(Continued)

(58) **Field of Classification Search**
CPC A61B 5/061
See application file for complete search history.

(56) **References Cited**

U.S. PATENT DOCUMENTS

3,219,969 A * 11/1965 Snavelly G01S 1/72
116/137 A
4,353,110 A 10/1982 Ellis
(Continued)

FOREIGN PATENT DOCUMENTS

CA 2571508 1/2006
CN 2698283 Y 5/2005
(Continued)

OTHER PUBLICATIONS

Office Action for Canadian Application No. 2,759,694, mailed Feb. 17, 2016.

(Continued)

Primary Examiner — Christian Sevilla

(57) **ABSTRACT**

A field generator for use in a surgical targeting system is disclosed. The field generator includes a mounting structure including elements that are configured to receive components of an electromagnetic field generator. The elements are disposed on the mounting structure at locations and orientations relative to each other. The field generator includes at least one covering formed over the mounting structure, wherein, in use, the locations and orientations of the elements relative to each other remain substantially unaltered after exposure to one or more sterilization processes.

20 Claims, 44 Drawing Sheets

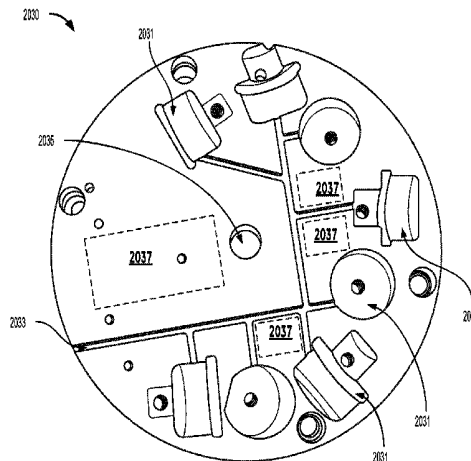
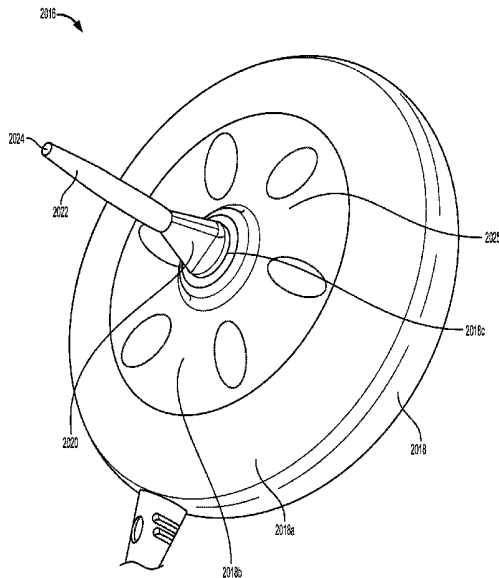

Related U.S. Application Data

division of application No. 12/768,689, filed on Apr. 27, 2010, now Pat. No. 8,945,147, which is a continuation-in-part of application No. 12/547,716, filed on Aug. 26, 2009, now Pat. No. 8,784,425.

(60) Provisional application No. 61/173,069, filed on Apr. 27, 2009.

(51) **Int. Cl.**

A61B 5/05 (2006.01)
A61B 5/11 (2006.01)
A61B 17/17 (2006.01)
A61B 17/72 (2006.01)
A61L 2/07 (2006.01)
A61L 2/08 (2006.01)
H01F 41/00 (2006.01)
A61B 5/00 (2006.01)
A61B 34/20 (2016.01)
A61B 90/00 (2016.01)

(52) **U.S. Cl.**

CPC *A61B 17/1703* (2013.01); *A61B 17/1707* (2013.01); *A61B 17/7233* (2013.01); *A61B 34/20* (2016.02); *A61B 90/39* (2016.02); *A61L 2/07* (2013.01); *A61L 2/081* (2013.01); *H01F 41/00* (2013.01); *A61B 5/4504* (2013.01); *A61B 17/1725* (2013.01); *A61B 2019/547* (2013.01); *A61B 2034/2051* (2016.02); *A61B 2034/2072* (2016.02); *A61B 2090/0813* (2016.02); *A61B 2090/363* (2016.02); *A61B 2090/3958* (2016.02); *Y10T 29/4902* (2015.01)

(56) **References Cited**

U.S. PATENT DOCUMENTS

4,532,599 A 7/1985 Smith
 4,621,628 A 11/1986 Brudermann
 D297,047 S 8/1988 Hon et al.
 4,794,930 A 1/1989 Machida et al.
 4,803,976 A 2/1989 Frigg et al.
 4,905,698 A 3/1990 Strohl, Jr. et al.
 5,049,151 A 9/1991 Durham et al.
 5,127,913 A 7/1992 Thomas
 5,196,015 A 3/1993 Neubardt
 5,217,009 A 6/1993 Kronberg
 5,251,127 A 10/1993 Raab
 5,281,224 A 1/1994 Faccioli et al.
 5,320,625 A 6/1994 Bertin
 5,361,766 A 11/1994 Nichols et al.
 5,383,917 A 1/1995 Desai et al.
 5,411,503 A 5/1995 Hollstien et al.
 5,412,185 A 5/1995 Sturman
 5,417,688 A 5/1995 Elstrom et al.
 5,433,720 A 7/1995 Faccioli et al.
 5,514,145 A 5/1996 Durham et al.
 5,580,156 A * 12/1996 Suzuki B60Q 7/00
 116/63 P
 5,584,838 A 12/1996 Rona et al.
 5,585,783 A 12/1996 Hall
 5,957,836 A 9/1999 Johnson
 5,957,934 A 9/1999 Rapoport
 6,009,878 A 1/2000 Weijand et al.
 6,036,696 A 3/2000 Lambrecht et al.
 6,039,742 A 3/2000 Krettek et al.
 6,074,394 A * 6/2000 Krause A61B 17/1725
 606/86 R
 6,081,741 A 6/2000 Hollis
 6,106,528 A 8/2000 Durham et al.
 6,157,853 A 12/2000 Blume et al.
 6,162,228 A 12/2000 Durham
 6,168,595 B1 1/2001 Durham et al.

6,174,335 B1 1/2001 Varieur et al.
 6,212,419 B1 4/2001 Blume et al.
 6,233,490 B1 5/2001 Kasevich
 6,266,551 B1 7/2001 Osadchy et al.
 6,267,770 B1 7/2001 Truwit
 6,304,091 B1 10/2001 Shahoian et al.
 6,311,082 B1 10/2001 Creighton et al.
 6,474,341 B1 11/2002 Hunter et al.
 6,503,249 B1 1/2003 Krause
 6,529,765 B1 3/2003 Franck
 6,575,973 B1 6/2003 Shekalim
 6,636,757 B1 10/2003 Jascob et al.
 6,675,491 B2 1/2004 Sasaki et al.
 6,694,168 B2 2/2004 Traxel et al.
 6,718,194 B2 4/2004 Kienzle
 6,747,253 B1 6/2004 Firth et al.
 6,807,446 B2 10/2004 Fenn et al.
 6,890,332 B2 5/2005 Truckai et al.
 6,991,655 B2 1/2006 Iversen
 7,001,346 B2 2/2006 White
 7,029,478 B2 4/2006 Hollstien et al.
 7,060,075 B2 6/2006 Govari et al.
 D528,211 S 9/2006 Solar et al.
 7,130,676 B2 10/2006 Barrick
 7,152,608 B2 12/2006 Hunter et al.
 7,217,276 B2 5/2007 Henderson et al.
 7,253,611 B2 8/2007 Ma
 7,294,133 B2 11/2007 Zink et al.
 7,295,184 B2 11/2007 Suprun et al.
 7,358,481 B2 4/2008 Yeoh et al.
 7,477,926 B2 1/2009 McCombs
 7,532,997 B2 5/2009 Li et al.
 7,542,791 B2 6/2009 Mire et al.
 7,549,960 B2 6/2009 Govari
 7,559,931 B2 7/2009 Stone
 7,575,550 B1 8/2009 Govari
 7,634,306 B2 12/2009 Sarin et al.
 7,686,818 B2 3/2010 Simon et al.
 7,702,379 B2 4/2010 Avinash et al.
 7,727,240 B1 6/2010 Benton
 7,729,742 B2 6/2010 Govari
 7,780,681 B2 8/2010 Sarin et al.
 7,785,330 B2 8/2010 Sherman et al.
 7,835,785 B2 11/2010 Scully et al.
 7,840,254 B2 11/2010 Glossop
 7,846,162 B2 12/2010 Nelson et al.
 7,918,853 B2 4/2011 Watanabe
 7,925,068 B2 4/2011 Hoctor et al.
 7,927,338 B2 4/2011 Laffargue et al.
 7,949,386 B2 5/2011 Buly et al.
 7,955,280 B2 6/2011 Radinsky et al.
 8,007,448 B2 8/2011 Moctezuma
 8,057,479 B2 11/2011 Stone
 8,066,706 B2 11/2011 Schlienger et al.
 8,167,823 B2 5/2012 Nycz et al.
 8,176,922 B2 5/2012 Sherman et al.
 8,197,494 B2 6/2012 Jaggi
 8,211,108 B2 7/2012 Matityahu
 8,241,296 B2 8/2012 Wasielewski
 8,251,994 B2 8/2012 McKenna et al.
 8,301,262 B2 10/2012 Mi et al.
 8,337,426 B2 12/2012 Nycz
 8,400,312 B2 3/2013 Hotokebuchi et al.
 8,623,023 B2 1/2014 Ritchey et al.
 8,890,511 B2 11/2014 Belew
 8,945,147 B2 2/2015 Ritchey
 8,997,362 B2 4/2015 Briggs et al.
 2002/0032445 A1 3/2002 Fujiwara
 2002/0052604 A1 5/2002 Simon et al.
 2002/0077540 A1 6/2002 Kienzle
 2002/0173792 A1 11/2002 Severns et al.
 2003/0012342 A1 1/2003 Suhm
 2003/0055436 A1 3/2003 Daum
 2003/0105470 A1 6/2003 White
 2003/0120150 A1 6/2003 Govari
 2003/0135211 A1 7/2003 Cho
 2003/0153829 A1 8/2003 Sarin et al.
 2003/0164172 A1 9/2003 Chumas et al.
 2003/0208122 A1 11/2003 Melkent et al.

(56)

References Cited

U.S. PATENT DOCUMENTS

2004/0011365	A1	1/2004	Govari et al.	2008/0255560	A1	10/2008	Myers et al.
2004/0034355	A1	2/2004	Govari et al.	2008/0269596	A1	10/2008	Revie et al.
2004/0073228	A1	4/2004	Kienzle	2008/0281326	A1	11/2008	Watanabe et al.
2004/0077940	A1	4/2004	Kienzle	2008/0281334	A1	11/2008	Zheng et al.
2004/0097952	A1	5/2004	Sarin et al.	2009/0024023	A1	1/2009	Welches et al.
2004/0147926	A1	7/2004	Iversen	2009/0054910	A1	2/2009	Zheng et al.
2004/0230199	A1	11/2004	Jansen et al.	2009/0088756	A1	4/2009	Anderson
2004/0243148	A1	12/2004	Wasielewski	2009/0099404	A1	4/2009	Kraus et al.
2004/0254584	A1	12/2004	Sarin et al.	2009/0138019	A1	5/2009	Wasielewski
2005/0027301	A1	2/2005	Stihl	2009/0165573	A1	7/2009	Ledoux et al.
2005/0027304	A1	2/2005	Leloup et al.	2009/0177080	A1	7/2009	Kristan et al.
2005/0035115	A1	2/2005	Anderson et al.	2009/0227862	A1	9/2009	Smith et al.
2005/0035116	A1	2/2005	Brown et al.	2009/0248044	A1	10/2009	Amiot
2005/0043726	A1	2/2005	McHale et al.	2009/0306665	A1	12/2009	Lerner et al.
2005/0059885	A1	3/2005	Melkent et al.	2009/0306666	A1	12/2009	Czartoski et al.
2005/0070916	A1	3/2005	Hollstien et al.	2009/0326537	A1	12/2009	Anderson
2005/0075562	A1	4/2005	Szakelyhidi et al.	2010/0041985	A1	2/2010	Simon et al.
2005/0075632	A1	4/2005	Russell et al.	2010/0063508	A1	3/2010	Borja et al.
2005/0080335	A1	4/2005	Simon et al.	2010/0064216	A1	3/2010	Borja et al.
2005/0080427	A1	4/2005	Govari et al.	2010/0069911	A1	3/2010	Borja et al.
2005/0085714	A1	4/2005	Foley et al.	2010/0076505	A1	3/2010	Borja
2005/0085715	A1	4/2005	Dukesherer et al.	2010/0100011	A1	4/2010	Roche
2005/0099290	A1	5/2005	Govari	2010/0130851	A1	5/2010	Neidert
2005/0124988	A1	6/2005	Terrill-Grisoni et al.	2010/0137869	A1	6/2010	Borja et al.
2005/0143726	A1	6/2005	Bortkiewicz	2010/0137871	A1	6/2010	Borja
2005/0148855	A1	7/2005	Kienzle	2010/0145337	A1	6/2010	Janna et al.
2005/0149050	A1	7/2005	Stifter et al.	2010/0152566	A1	6/2010	Rains et al.
2005/0171545	A1	8/2005	Walsh	2010/0152573	A1	6/2010	Ritchey et al.
2005/0197569	A1	9/2005	McCombs	2010/0210939	A1	8/2010	Hartmann
2005/0203528	A1	9/2005	Couture	2010/0211177	A1	8/2010	Abdou
2005/0209605	A1	9/2005	Grimm	2010/0249576	A1	9/2010	Askarinya
2005/0228270	A1	10/2005	Lloyd et al.	2010/0249657	A1	9/2010	Nycz et al.
2005/0242087	A1	11/2005	Anderson et al.	2010/0261998	A1	10/2010	Stiehl
2005/0245821	A1	11/2005	Govari et al.	2010/0274121	A1	10/2010	Ritchey et al.
2005/0261700	A1	11/2005	Tuma et al.	2010/0274253	A1	10/2010	Ure
2006/0015031	A1	1/2006	Kienzle	2010/0274256	A1	10/2010	Ritchey
2006/0029186	A1	2/2006	De Villiers et al.	2010/0274306	A1	10/2010	Pastore et al.
2006/0052782	A1	3/2006	Morgan et al.	2010/0289491	A1	11/2010	Budker et al.
2006/0074405	A1	4/2006	Malackowski et al.	2010/0312245	A1	12/2010	Tipirneni et al.
2006/0084867	A1	4/2006	Tremblay	2010/0324412	A1	12/2010	Govari
2006/0095047	A1	5/2006	de la Barrera	2011/0054297	A1	3/2011	Bulitta
2006/0106400	A1	5/2006	Fernandez et al.	2011/0054449	A1	3/2011	Tien
2006/0122618	A1	6/2006	Claypool	2011/0082366	A1	4/2011	Scully
2006/0142656	A1	6/2006	Malackowski et al.	2011/0109311	A1	5/2011	Walsh
2006/0190011	A1	8/2006	Ries	2011/0130765	A1	6/2011	Fernandez et al.
2006/0264731	A1	11/2006	Murphy	2011/0208037	A1	8/2011	Rains et al.
2006/0282168	A1	12/2006	Sherman et al.	2011/0208093	A1	8/2011	Gross
2006/0287613	A1	12/2006	Amiot et al.	2011/0218458	A1	9/2011	Valin
2006/0293593	A1	12/2006	Govari et al.	2011/0230886	A1	9/2011	Gustilo et al.
2006/0293614	A1	12/2006	Radinsky et al.	2011/0237936	A1	9/2011	Kalpin
2007/0093709	A1	4/2007	Abernathie	2011/0257518	A1	10/2011	Buly et al.
2007/0129629	A1	6/2007	Beauregard et al.	2011/0270080	A1	11/2011	Crane
2007/0149977	A1	6/2007	Heavener	2011/0288600	A1	11/2011	Ritchey et al.
2007/0162018	A1	7/2007	Jensen et al.	2011/0295108	A1	12/2011	Cox
2007/0167744	A1	7/2007	Beauregard et al.	2011/0295253	A1	12/2011	Bonutti et al.
2007/0191827	A1	8/2007	Lischinsky et al.	2011/0308536	A1	12/2011	Govari
2007/0208251	A1	9/2007	Anderson et al.	2012/0010500	A1	1/2012	Couture et al.
2007/0219409	A1	9/2007	Shimizu et al.	2012/0022406	A1	1/2012	Hladio et al.
2007/0225595	A1	9/2007	Malackowski et al.	2012/0029578	A1	2/2012	Suh
2007/0249967	A1	10/2007	Buly et al.	2012/0035468	A1	2/2012	Ritchey et al.
2007/0255132	A1	11/2007	Shalgi et al.	2012/0053585	A1	3/2012	Nycz et al.
2007/0276370	A1	11/2007	Altarac et al.	2012/0091122	A1	4/2012	Ahmad et al.
2007/0282440	A1	12/2007	Visentin	2012/0101361	A1	4/2012	Rains et al.
2008/0015551	A1	1/2008	Feine et al.	2012/0109228	A1	5/2012	Boyer
2008/0021309	A1	1/2008	Amiot et al.	2012/0136402	A1	5/2012	Burroughs
2008/0039857	A1	2/2008	Giersch et al.	2012/0143047	A1	6/2012	Kimura
2008/0051910	A1	2/2008	Kammerzell et al.	2012/0168587	A1	7/2012	Karsak
2008/0071142	A1	3/2008	Gattani et al.	2012/0184844	A1	7/2012	Gielen
2008/0086145	A1	4/2008	Sherman et al.	2012/0187941	A1	7/2012	Belew
2008/0146969	A1	6/2008	Kurtz	2012/0209117	A1	8/2012	Mozes et al.
2008/0154266	A1	6/2008	Protopsaltis et al.	2012/0220107	A1	8/2012	Fukuda et al.
2008/0195109	A1	8/2008	Hunter	2012/0220859	A1	8/2012	Amiot
2008/0221628	A1	9/2008	Milbocker et al.	2012/0226094	A1	9/2012	Ritchey et al.
2008/0228195	A1	9/2008	von Jacko et al.	2012/0227542	A1	9/2012	Koch
2008/0255544	A1	10/2008	Gielen	2012/0232561	A1	9/2012	Fernandez
				2012/0253354	A1	10/2012	Arlettaz et al.
				2012/0283599	A1	11/2012	Borja
				2012/0323247	A1	12/2012	Bettenga
				2012/0330191	A1	12/2012	Hulliger et al.

(56)

References Cited

OTHER PUBLICATIONS

U.S. PATENT DOCUMENTS

2013/0018381 A1 1/2013 Baumgartner
 2013/0079829 A1 3/2013 Globerman et al.
 2013/0131679 A1 5/2013 Janna et al.
 2013/0218007 A1 8/2013 Petteys et al.
 2013/0238036 A1 9/2013 Sinha
 2013/0289573 A1 10/2013 Heilala et al.
 2013/0303886 A1 11/2013 Ludwin
 2013/0331717 A1 12/2013 Ludwin
 2014/0052149 A1 2/2014 van der Walt et al.
 2014/0081121 A1 3/2014 Wilhelm et al.
 2014/0221803 A1 8/2014 Bar-Tal
 2015/0080893 A1 3/2015 Graca et al.
 2015/0245786 A1 9/2015 Lee et al.

FOREIGN PATENT DOCUMENTS

CN 201029876 3/2008
 DE 102008023760 12/2009
 EP 523905 5/1993
 EP 628287 4/1995
 EP 1391181 2/2004
 EP 1570782 9/2005
 EP 1382308 11/2005
 EP 1803394 7/2007
 EP 1570781 9/2009
 EP 2130511 12/2009
 EP 1563810 3/2010
 EP 1743590 10/2010
 GR 1005791 1/2008
 JP 2004130094 A 4/2004
 WO WO9500085 1/1995
 WO WO9713467 4/1997
 WO WO9832387 7/1998
 WO WO9947052 9/1999
 WO WO0134016 10/2001
 WO WO02062250 8/2002
 WO WO03044556 5/2003
 WO WO03073951 9/2003
 WO WO03041611 12/2003
 WO WO03105659 12/2003
 WO WO2004030556 4/2004
 WO WO2004001569 7/2004
 WO WO2004069063 8/2004
 WO WO2004091419 11/2004
 WO WO2004112610 12/2004
 WO WO2005023110 3/2005
 WO WO2005084572 9/2005
 WO WO2005087125 9/2005
 WO WO2005120203 12/2005
 WO WO2006060632 6/2006
 WO WO2007009088 1/2007
 WO WO2007025191 3/2007
 WO WO2007061890 5/2007
 WO WO2006094119 11/2007
 WO WO2007133168 11/2007
 WO WO2008105874 9/2008
 WO WO2008106593 9/2008
 WO WO2009046547 4/2009
 WO WO2009108214 9/2009
 WO WO2009131999 10/2009
 WO WO2010011978 1/2010
 WO WO2010028046 3/2010
 WO WO2010099247 9/2010
 WO WO2010111272 9/2010
 WO WO2010124164 A1 10/2010
 WO WO2010129141 11/2010
 WO WO2010129308 11/2010
 WO WO2011060536 5/2011
 WO WO2011124661 10/2011
 WO WO2012080840 6/2012
 WO WO2013049534 4/2013

Patent Examination Report No. 1 for Australian Application No. 2015202388, mailed Mar. 2, 2016.
 Office Action for Canadian Application No. 2,777,468, mailed Nov. 25, 2016.
 Extended European Search Report for European Application No. 12800328.2, mailed May 27, 2015.
 Canadian Office Action for Application No. 2,678,369, mailed Sep. 4, 2015.
 Notice of Reasons for Rejection in Japanese Application 2014-249827, mailed Oct. 5, 2015.
 Office Action for U.S. Appl. No. 14/114,940, mailed Mar. 30, 2016.
 Office Action for U.S. Appl. No. 13/323,010, mailed Jan. 19, 2016.
 Office Action in Canadian Application No. 2,759,694, mailed Feb. 17, 2016.
 Office Action for U.S. Appl. No. 12/758,747, mailed Aug. 11, 2014.
 Office Action for U.S. Appl. No. 12/547,716, mailed Sep. 18, 2012.
 Patent Examination Report No. 1 from Australian Application No. 2010245179, mailed Dec. 5, 2014.
 Office Action for U.S. Appl. No. 12/527,997, mailed Oct. 29, 2012.
 Second Office Action for Chinese Application No. 200880006490.9 mailed Apr. 26, 2012.
 Office Action for Australian Patent Application No. 2008221332, dated Jun. 15, 2012.
 Notice of Reasons for Rejection for Japanese Application No. 2010-548660 mailed Jan. 15, 2013.
 Office Action for U.S. Appl. No. 12/919,255, mailed Jan. 8, 2013.
 Office Action for U.S. Appl. No. 12/758,747, mailed Nov. 15, 2012.
 "Innomed Hip Instruments—hohmann retractors," reprinted from http://www.innomed.net/hip_rets_hohmanns.htm on Jan. 6, 2011, 8 pages.
 Office Action for European Application 08872996.7-1269, Jul. 21, 2011, 5 pages.
 International Search Report and Written Opinion for International Application No. PCT/US2010/032634, mailed Jan. 26, 2011, 10 pages.
 Notice of Reasons for Rejection for Japanese Application No. 2012-508518 mailed Dec. 10, 2013.
 Office Action in Russian Application No. 2011146914, mailed Dec. 16, 2013.
 Notice of Reasons for Rejection for Japanese Application No. 2012-508611, mailed Jan. 28, 2014.
 Ex Parte Quayle Action in U.S. Appl. No. 29/376,026, mailed Apr. 30, 2012, 10 pages.
 Office Action for U.S. Appl. No. 12/528,253, mailed Mar. 21, 2012, 9 pages.
 Office Action for U.S. Appl. No. 12/547,716, mailed Apr. 2, 2012, 11 pages.
 Office Action for U.S. Appl. No. 12/758,747, mailed Apr. 10, 2012, 11 pages.
 Rains, et al., U.S. Appl. No. 12/919,255, filed Aug. 25, 2010.
 International Search Report for International Application No. PCT/US2008/055300, mailed Sep. 17, 2008, 3 pages.
 International Preliminary Report on Patentability and Written Opinion for International Application No. PCT/US2007/063001, mailed Sep. 1, 2009, 5 pages.
 International Search Report for International Application No. PCT/US2007/063001, mailed Nov. 30, 2007, 3 pages.
 European Search Report for European Application No. 07830964.7, mailed Jun. 18, 2010, 4 pages.
 International Preliminary Report on Patentability and Written Opinion for International Application No. PCT/US2008/055300, mailed Sep. 1, 2009, 6 pages.
 Ritchey, et al., U.S. Appl. No. 29/376,026, filed Sep. 30, 2010.
 International Search Report and Written Opinion for PCT/US2010/030784, mailed Oct. 29, 2010, 11 pages.
 International Search Report for International Application No. PCT/US2008/074520, mailed Jan. 23, 2009, 2 pages.
 Office Action for Chinese Application No. 200880006490.9, mailed Mar. 31, 2011, 13 pages.
 Office Action for Russian Application No. 2011146669/14 mailed Apr. 3, 2014.

(56)

References Cited

OTHER PUBLICATIONS

Office Action for U.S. Appl. No. 13/358,065, mailed Jun. 3, 2014.
 International Search Report and Written Opinion for International Application No. PCT/US2010/051678, mailed Apr. 14, 2011, 8 pages.
 Ekliptik, Guiding Star, Lidis: The Best Solution for Distal Interlocking, 2008, 2 pages.
 Ekliptik, "Guiding Star", reprinted from <http://ekliptik.si/content/view/37/42>, on Jul. 1, 2010, 2 pages.
 First Office Action for Chinese Application No. 201080028779.8 mailed May 23, 2014.
 Office Action for U.S. Appl. No. 13/323,010, mailed Jun. 4, 2013.
 Office Action for U.S. Appl. No. 12/527,997, mailed May 21, 2013.
 International Search Report and Written Opinion for International Application No. PCT/US2012/041613, mailed Feb. 15, 2013.
 International Search Report and Written Opinion for International Application No. PCT/US2013/027042, mailed Jun. 12, 2013.
 Communication Pursuant to Article 94(3) EPC for European Application No. 07757660.1, mailed Jun. 5, 2013.
 Decision of Rejection for Japanese Application No. 2009-551851, mailed Jun. 11, 2013.
 Communication Pursuant to Article 94(3) EPC for European Application No. 08730964.7, mailed Jun. 6, 2013.
 Office Action for U.S. Appl. No. 13/123,792, mailed Jul. 2, 2013.
 Office Action for U.S. Appl. No. 13/030,801, mailed Mar. 13, 2013.
 International Search Report and Written Opinion for International Application PCT/US2012/022481, mailed Jul. 31, 2012.
 Office Action for U.S. Appl. No. 12/528,253, mailed Aug. 16, 2012.
 Office Action for U.S. Appl. No. 13/123,792, mailed Sep. 14, 2012.
 Office Action for U.S. Appl. No. 13/323,010, mailed Aug. 14, 2012.

First Office Action for Chinese Application No. 200880128908.3 mailed Apr. 24, 2012.

Association of Surgical Technologists, "AST Recommended Standards of Practice for Surgical Drapes," effective Apr. 13, 2008.

Ashar, Tom, "Ultrasound Guidance for Placement of Central Venous Catheters," Israeli Journal of Emergency Medicine, vol. 7, No. 2, Jun. 2007.

Buckner, C., et al., "Real-Time Sonography with Electromagnetic Tracking Navigation for Biopsy of a Hepatic Neoplasm Seen on Arterial Phase Computed Tomography," J Ultrasound Med 2011, 30:253-256.

"GE Healthcare: Ultrasound Imaging Accessories, vol. 6," CIVCO Medical Solutions, Multi-Modality Imaging, 2011.

"Guiding Star with the LIDIS module," Ekliptik, 2007.

Ekliptik, LIDIS module, brochure, 2010.

Brochure for GE Healthcare Drapes and Sterile Covers, accessed on Jun. 21, 2012, at <http://www.gehealthcare.com/usen/xr/surgery/docs/SurgeryDrapes&Film.pdf>.

Ekliptik, "User Manual: Guiding Star/LIDIS," Jun. 16, 2010, reprinted from http://www.ekliptik.si/html/downloads/documents/manuals/LIDIS_user_manual.pdf.

Medtronic, "Orthopaedic Navigation Solutions," 2005, reprinted from http://behzadisportsdoc.com/wordpress/wp-content/uploads/2011/05/medtronic_orthonavsolutions.pdf.

GE Healthcare, "Interventional X-ray, OEC C-arm," 2012.

Office Action for U.S. Appl. No. 12/919,255, mailed May 25, 2012.

Second Office Action for Chinese Application No. 201080028779.8, mailed Apr. 10, 2015.

Office Action for Canadian Application No. 2,777,468, mailed Jan. 19, 2016.

* cited by examiner

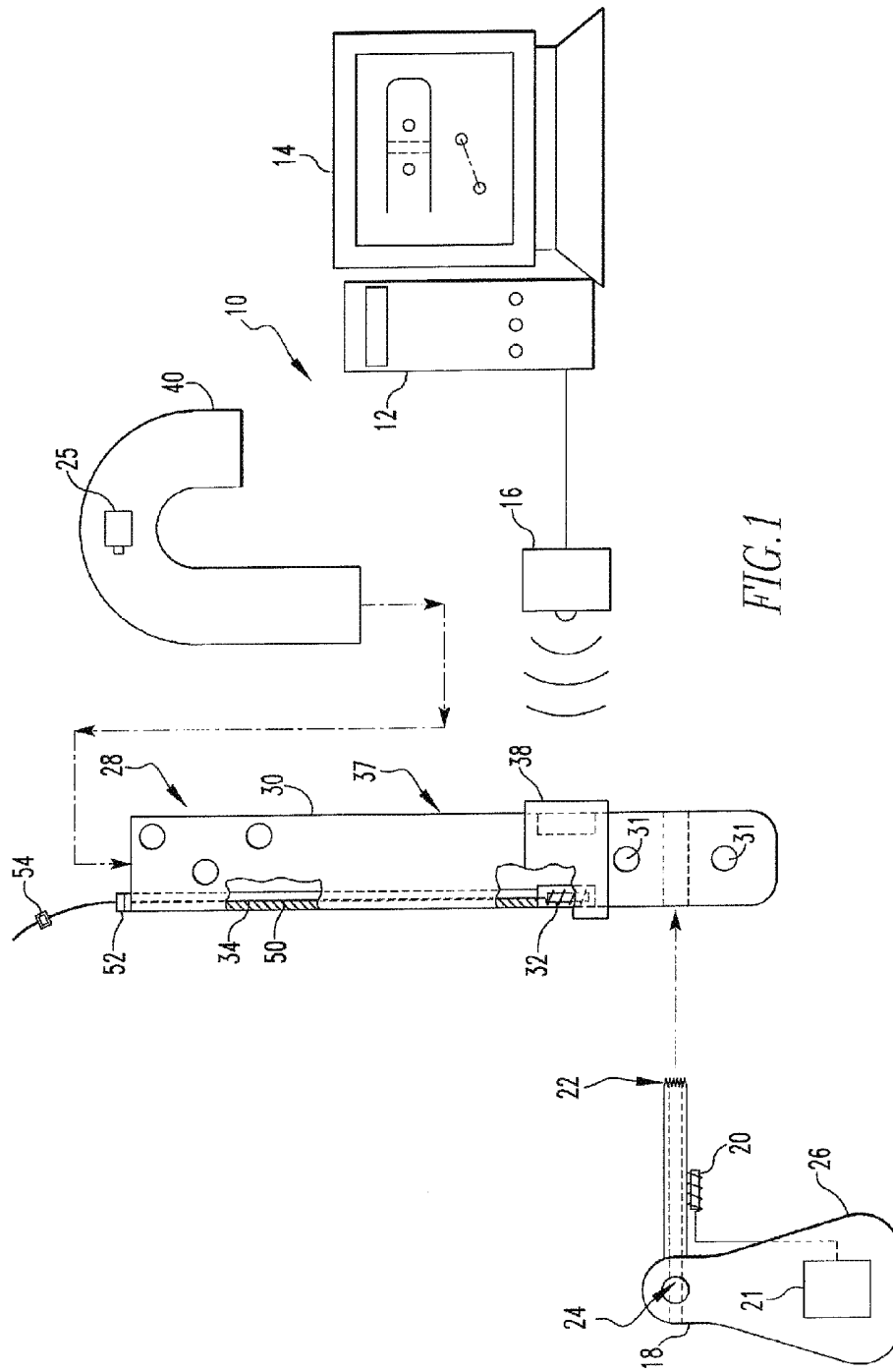

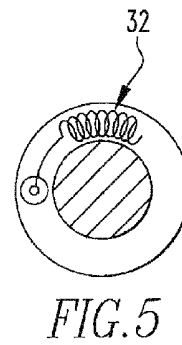
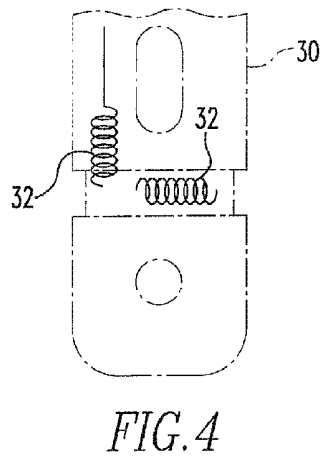
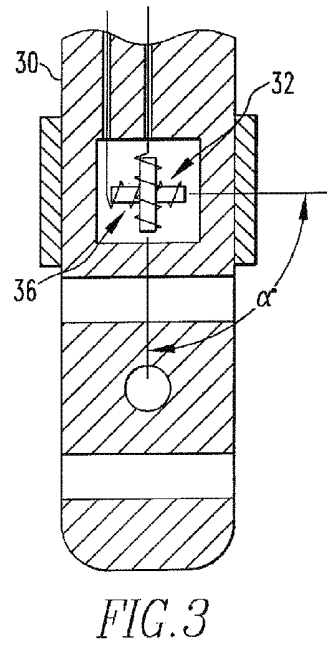
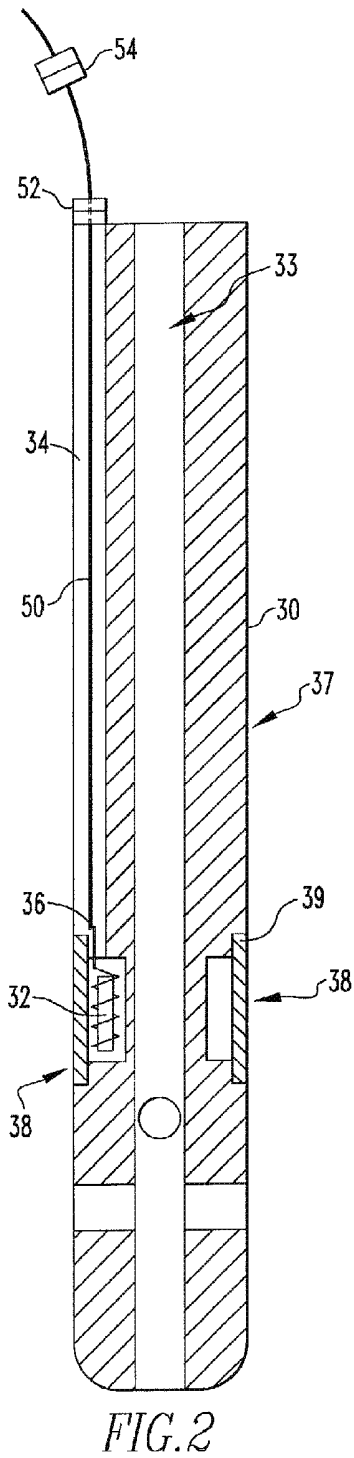

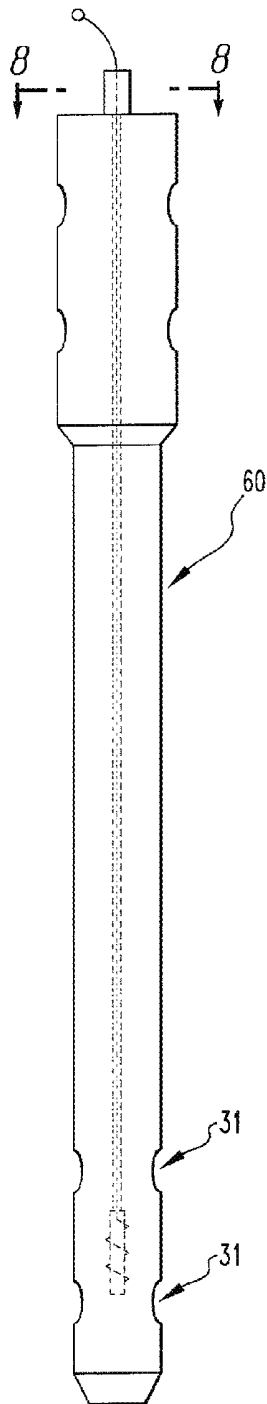

FIG. 6

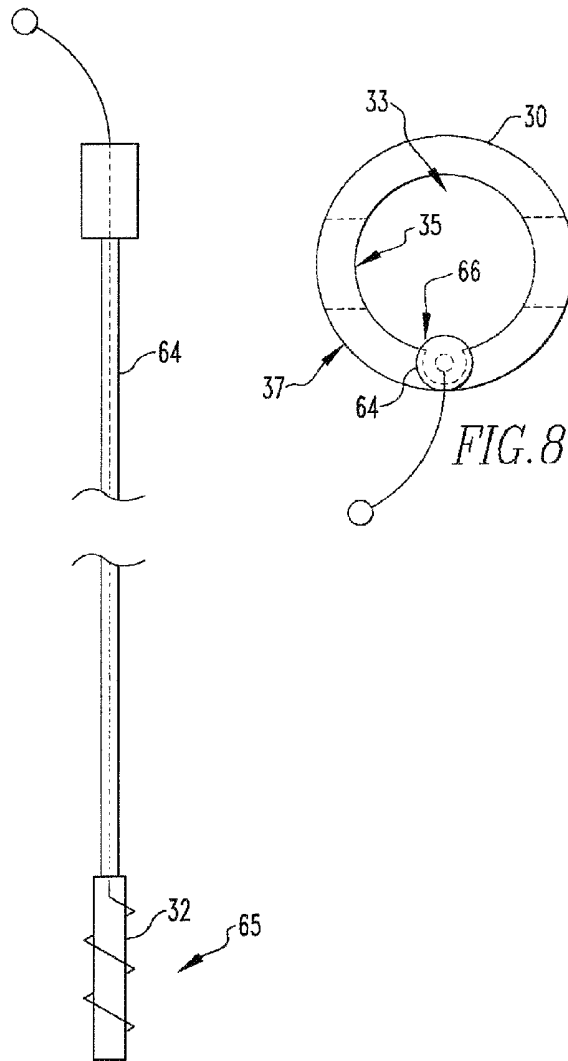

FIG. 7

FIG. 8

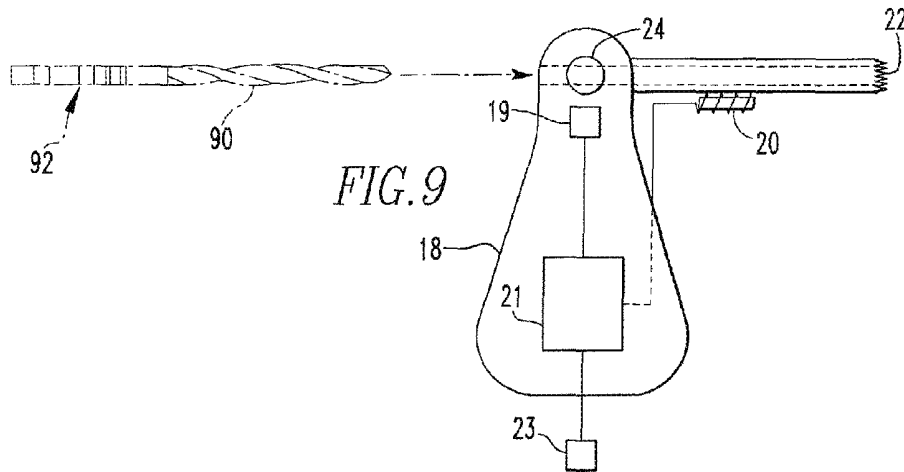

FIG. 9

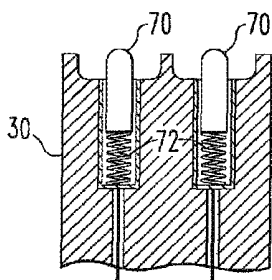

FIG. 10

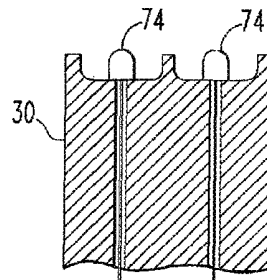

FIG. 11

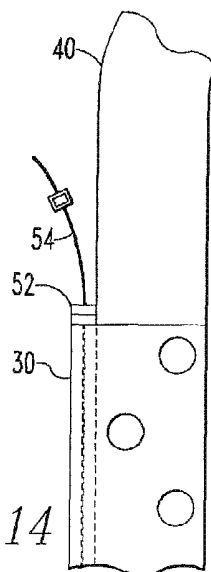

FIG. 14

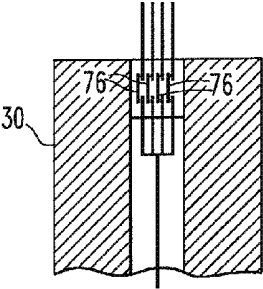

FIG. 12A

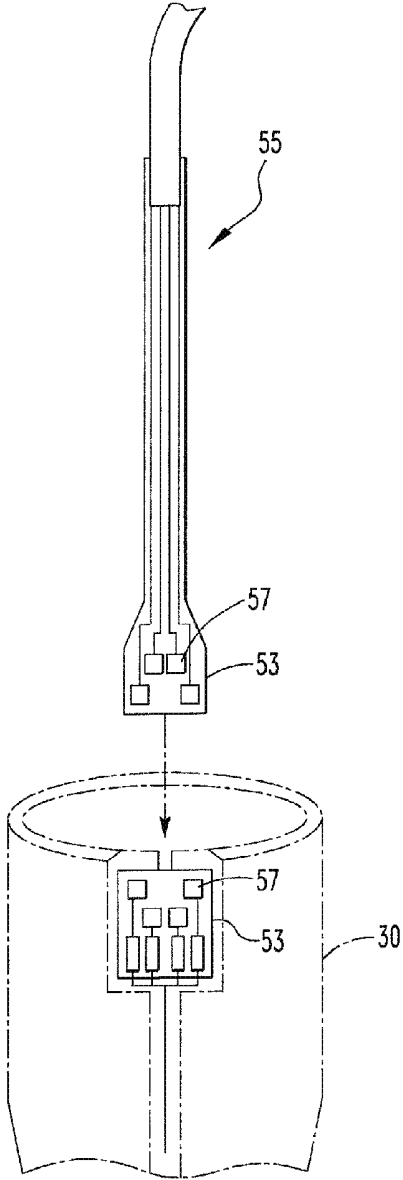

FIG. 12B

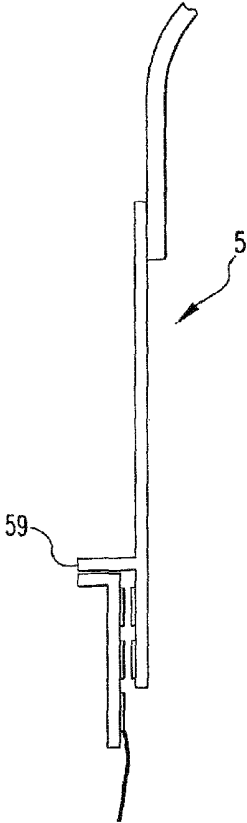

FIG. 12C

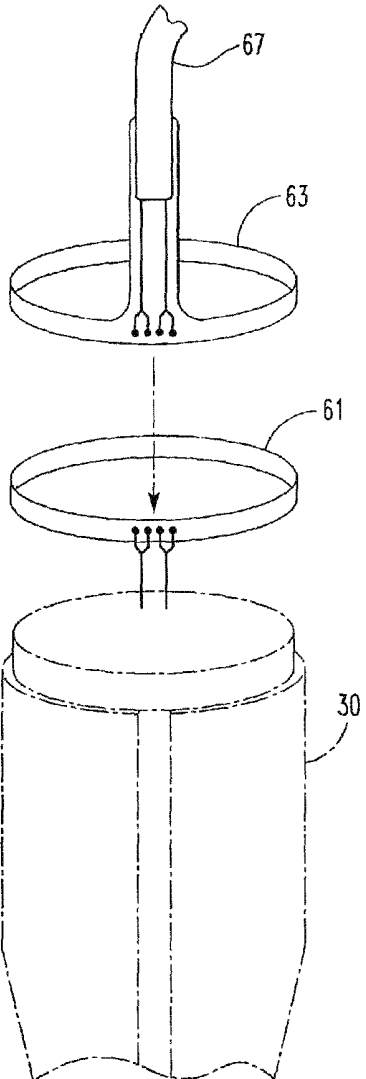

FIG. 12D

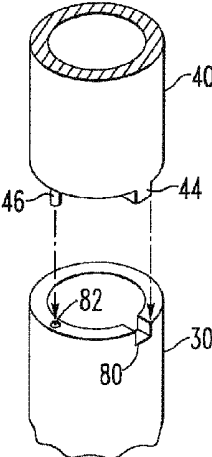

FIG. 13A

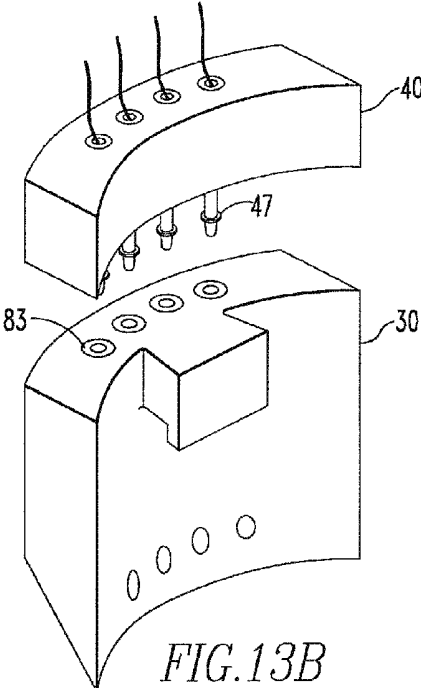
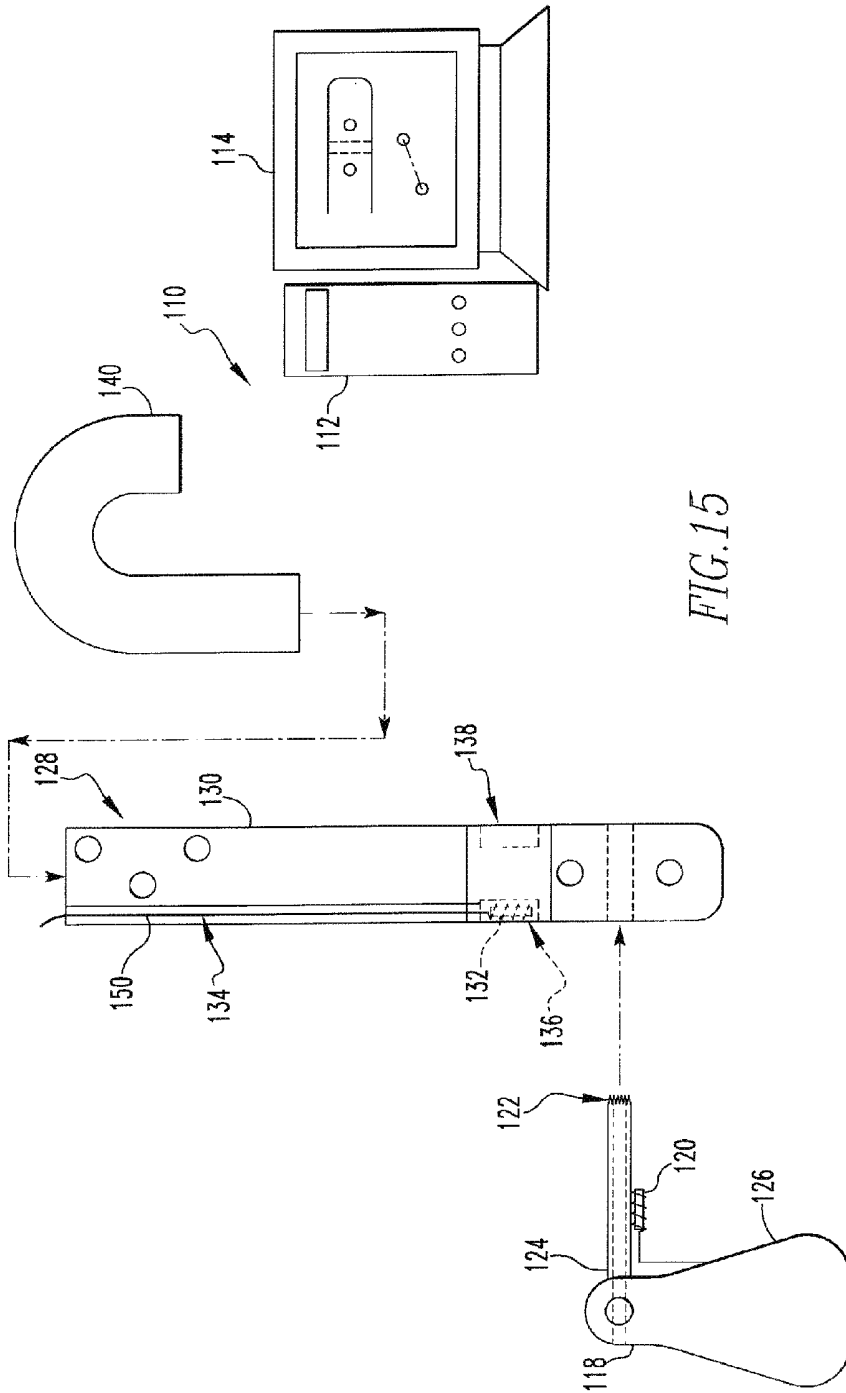
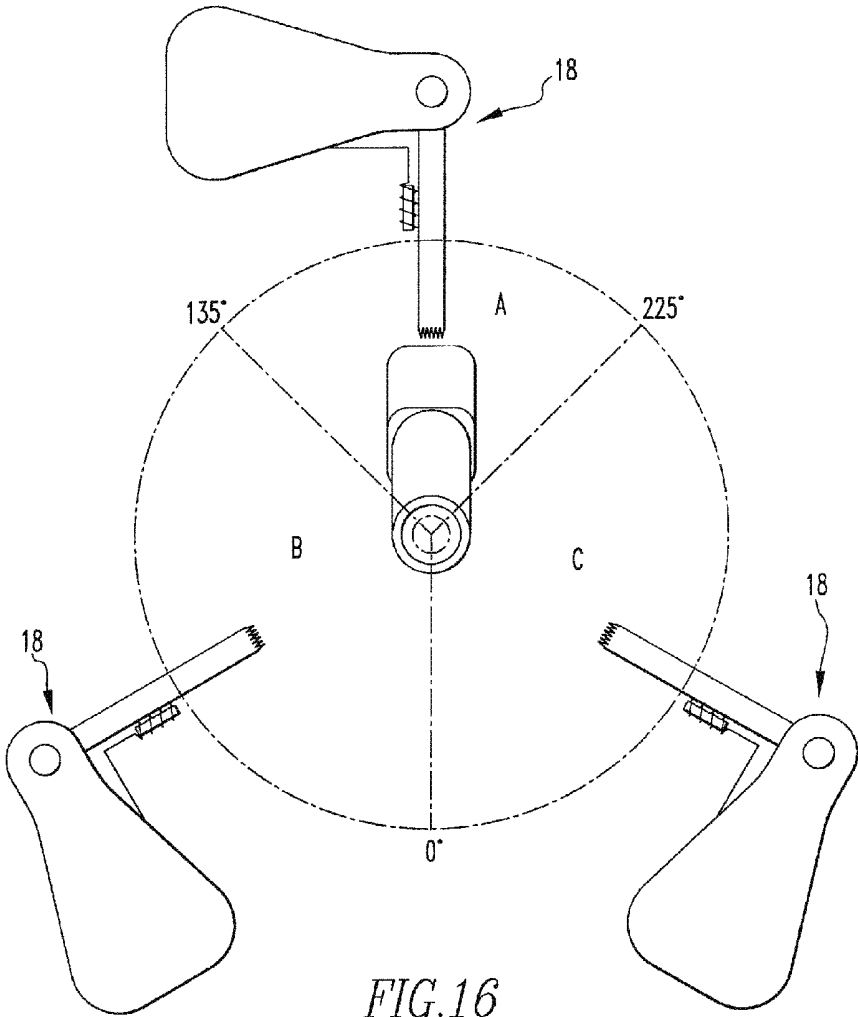

FIG. 13B





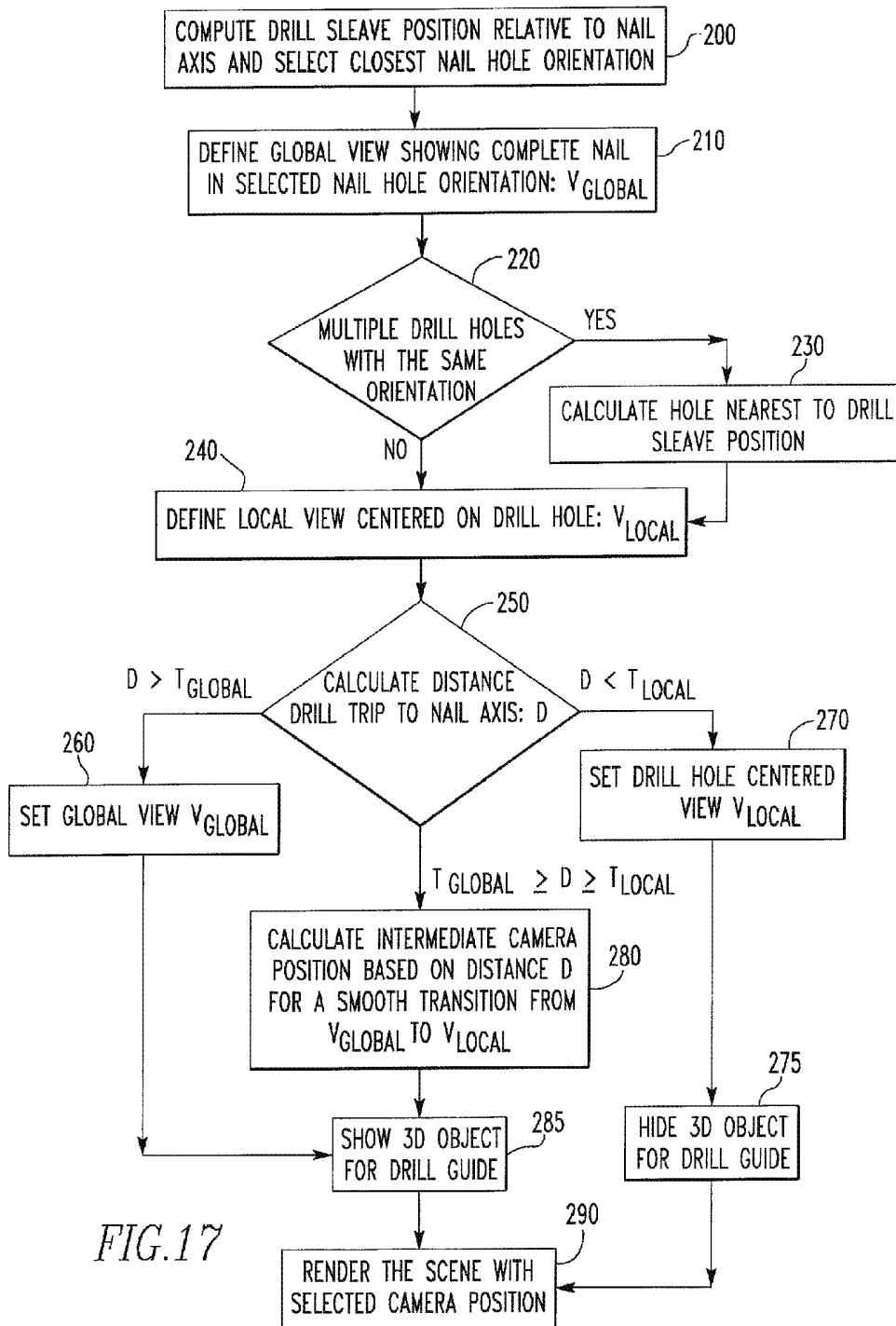
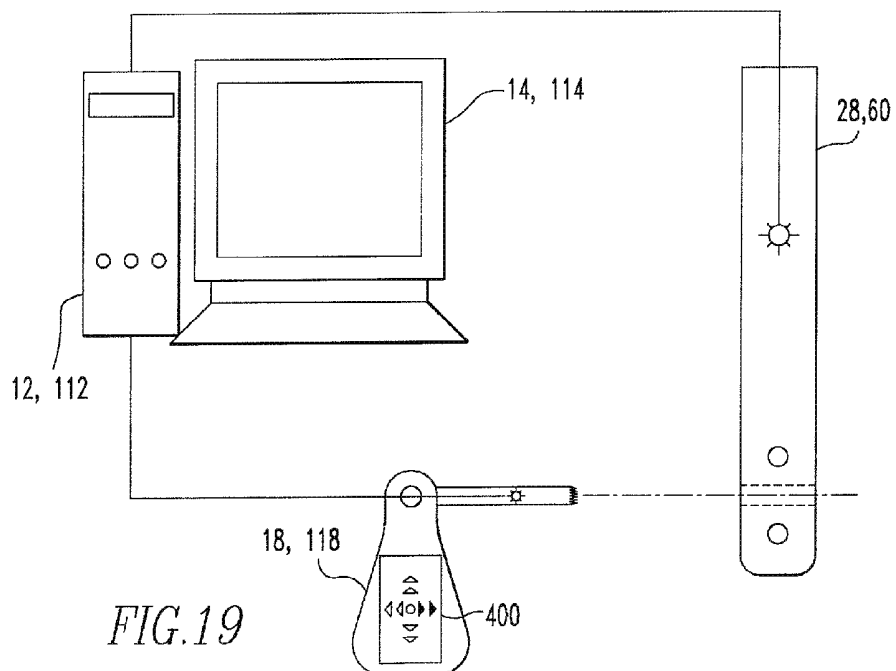
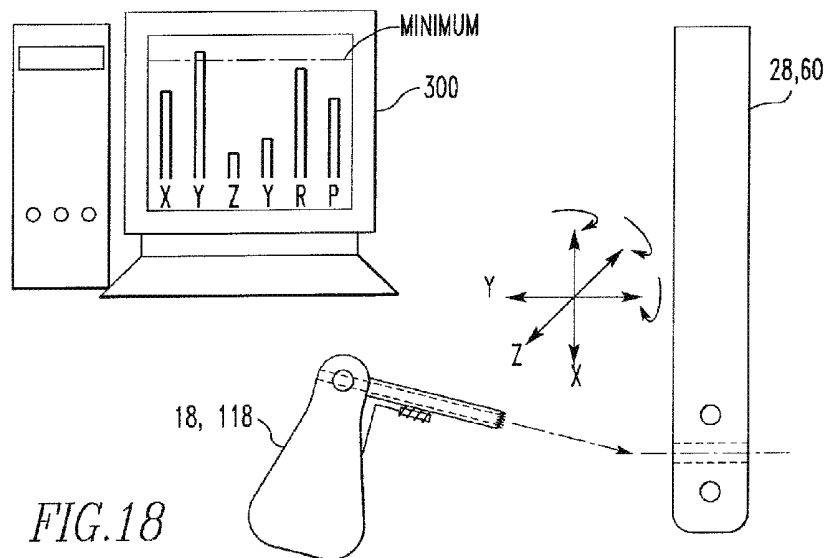
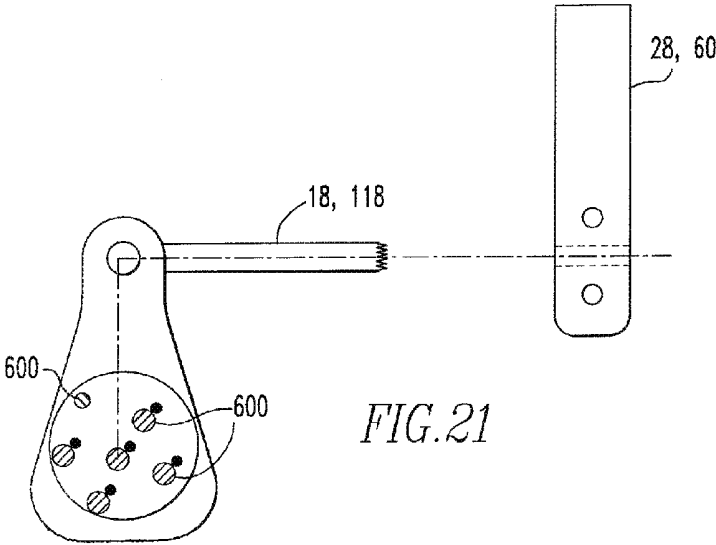
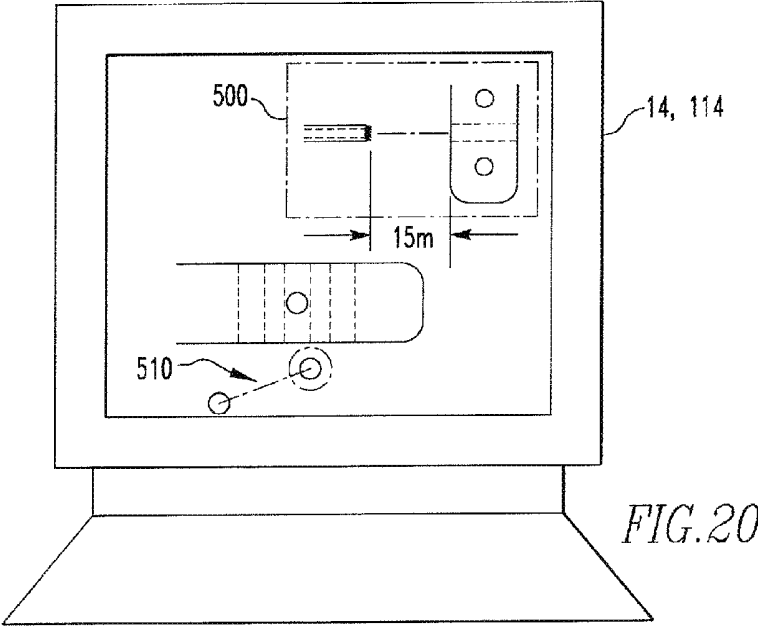

FIG.17





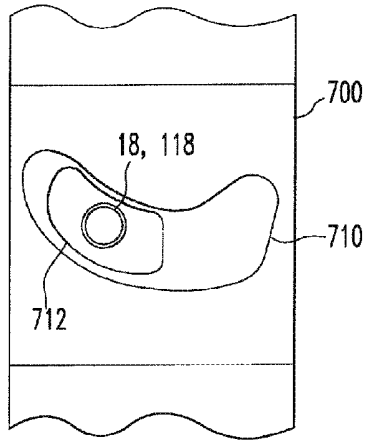

FIG. 22

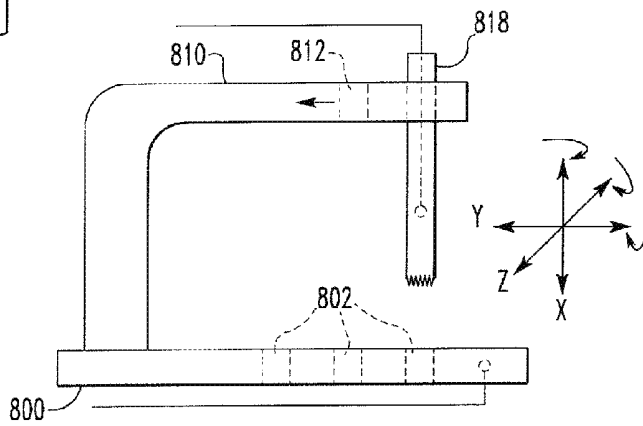

FIG. 23

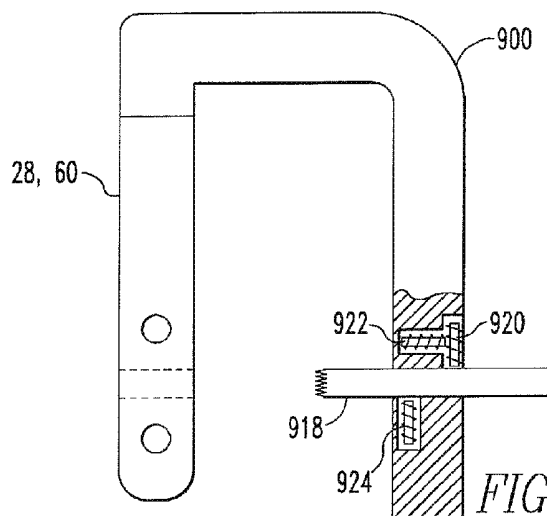

FIG. 24

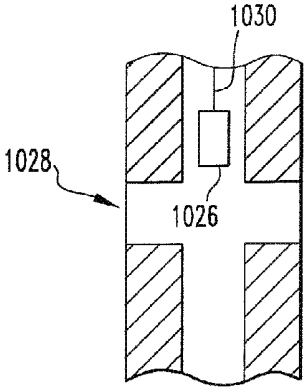

FIG.26

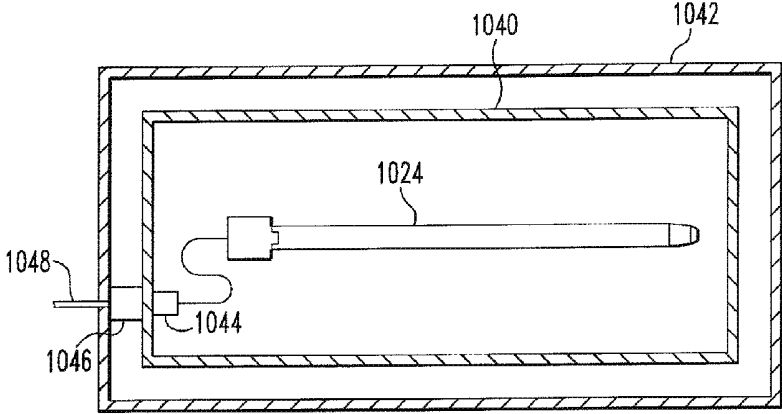

FIG.27

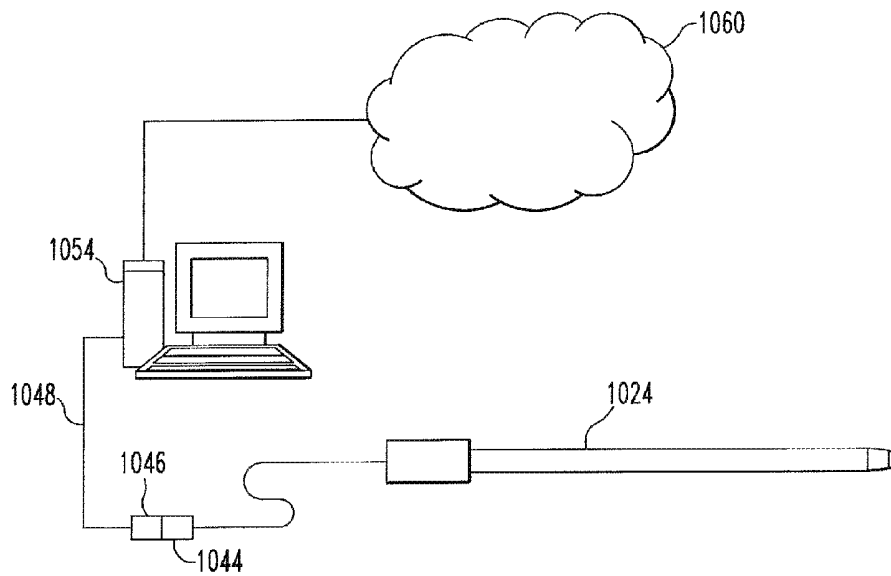

FIG. 28

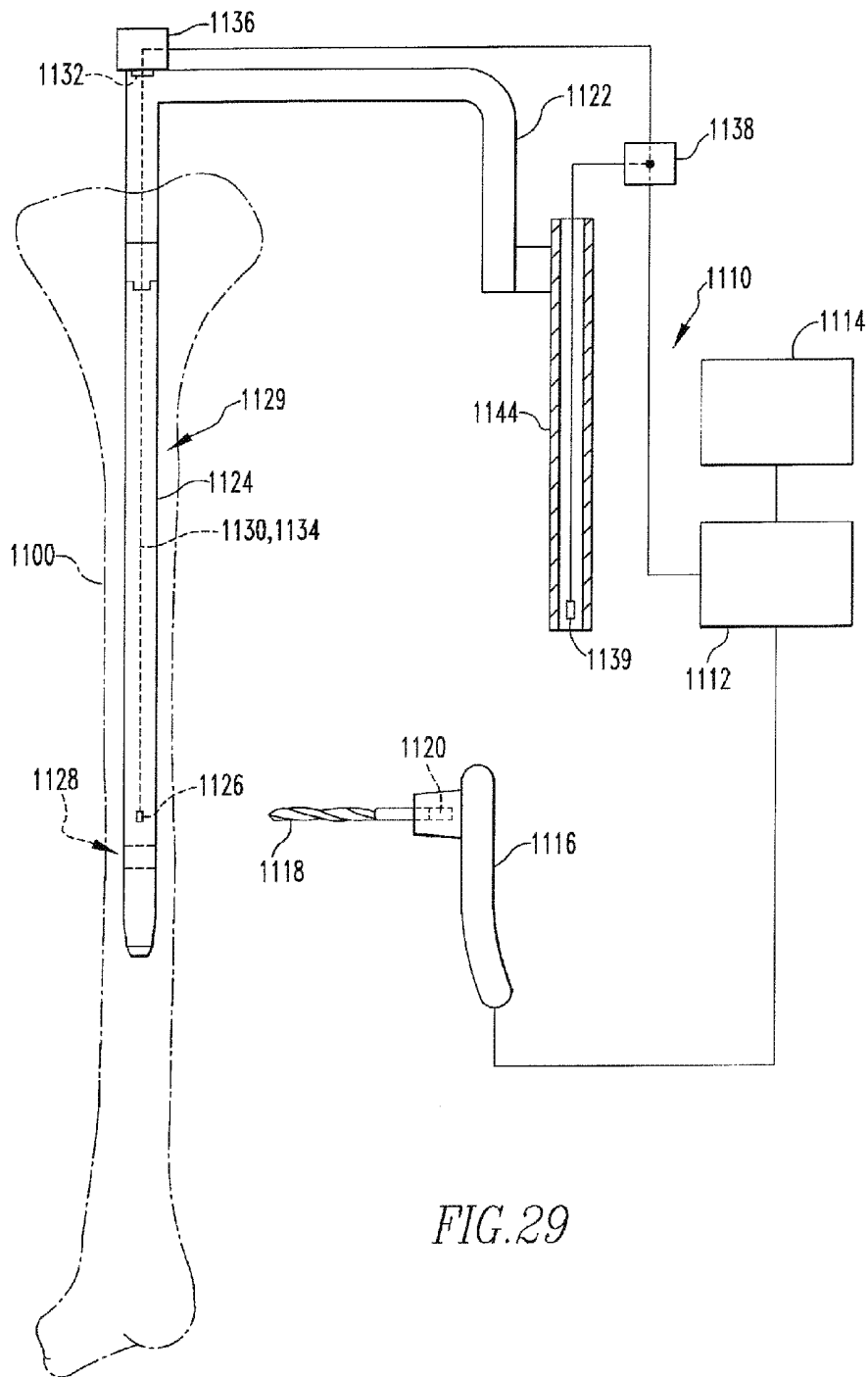

FIG. 29

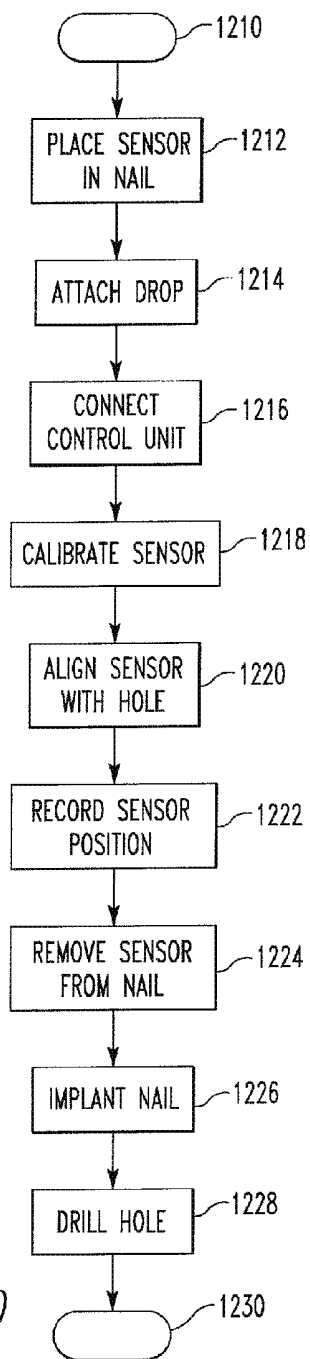

FIG. 30

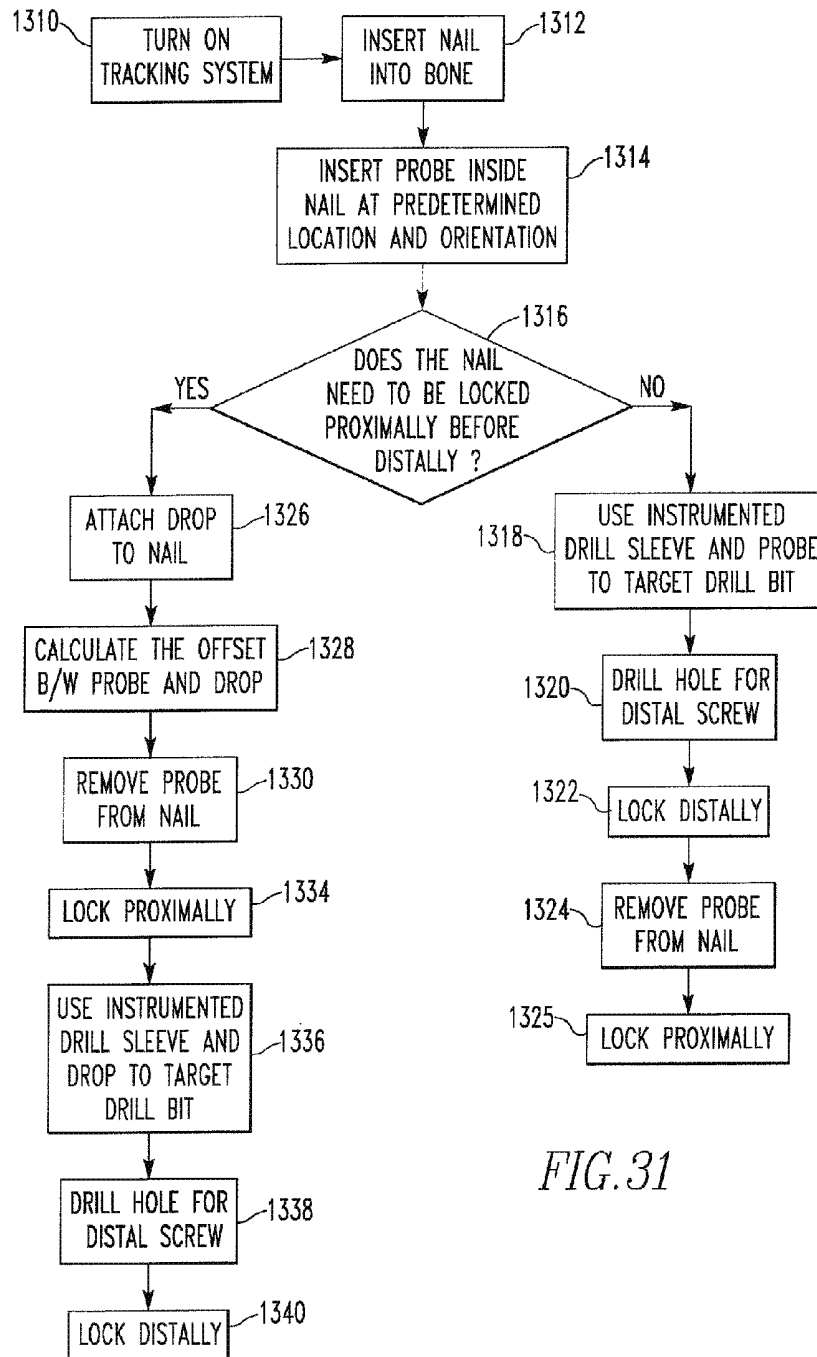
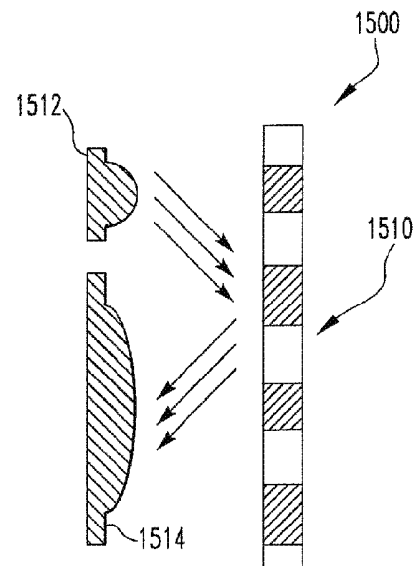
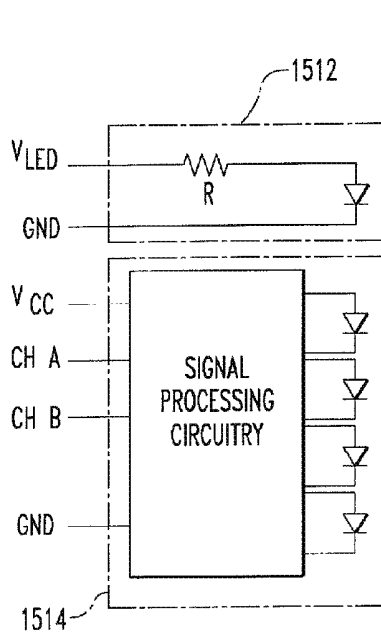
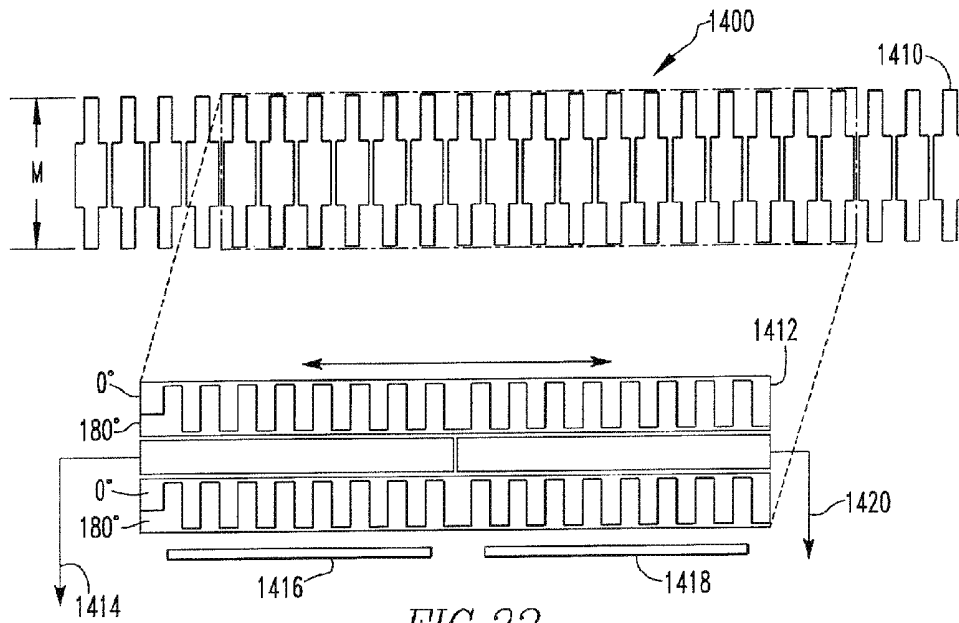
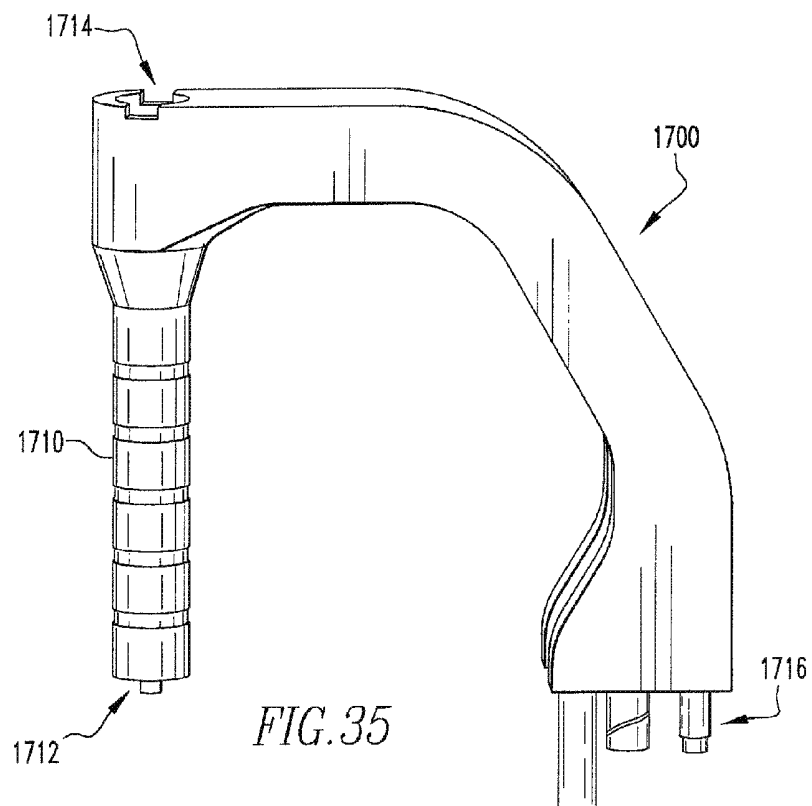
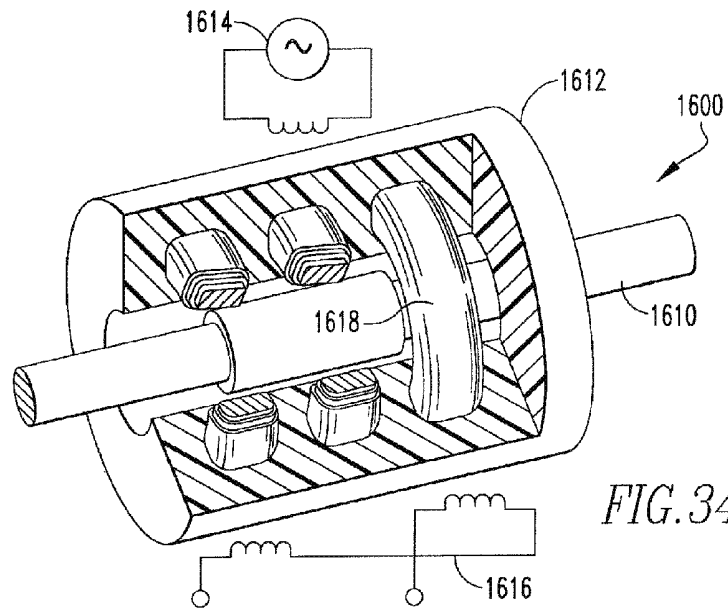
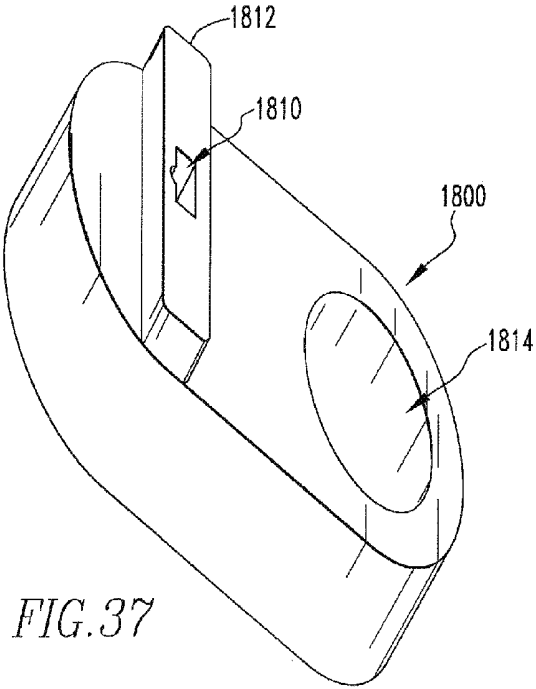
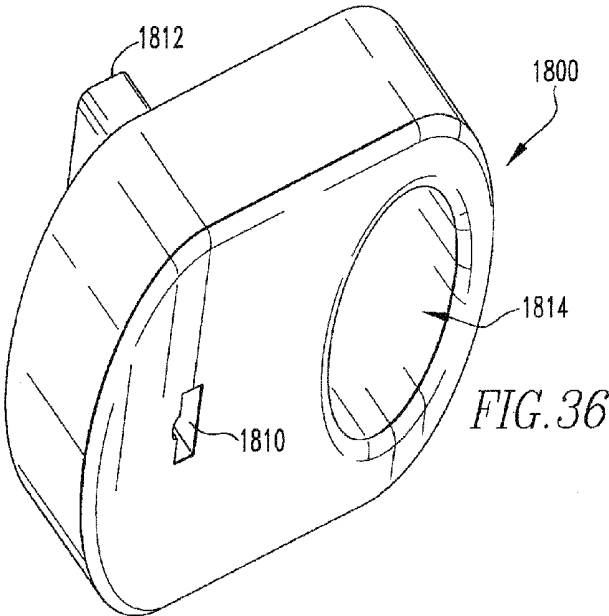

FIG. 31







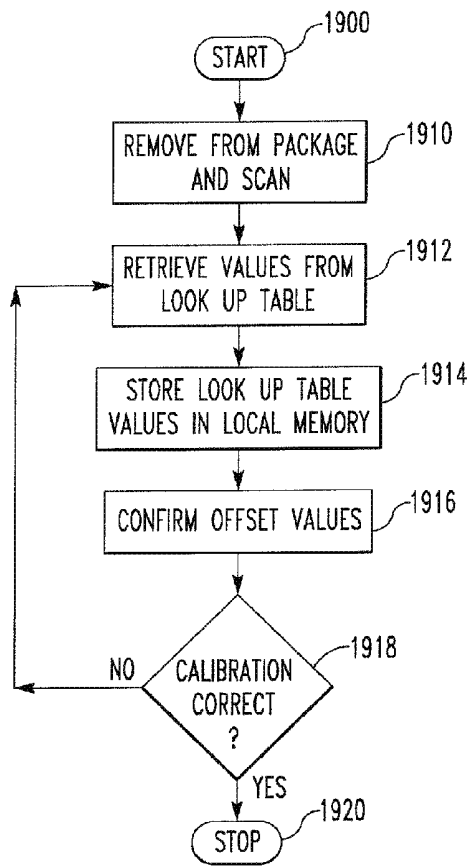

FIG. 38

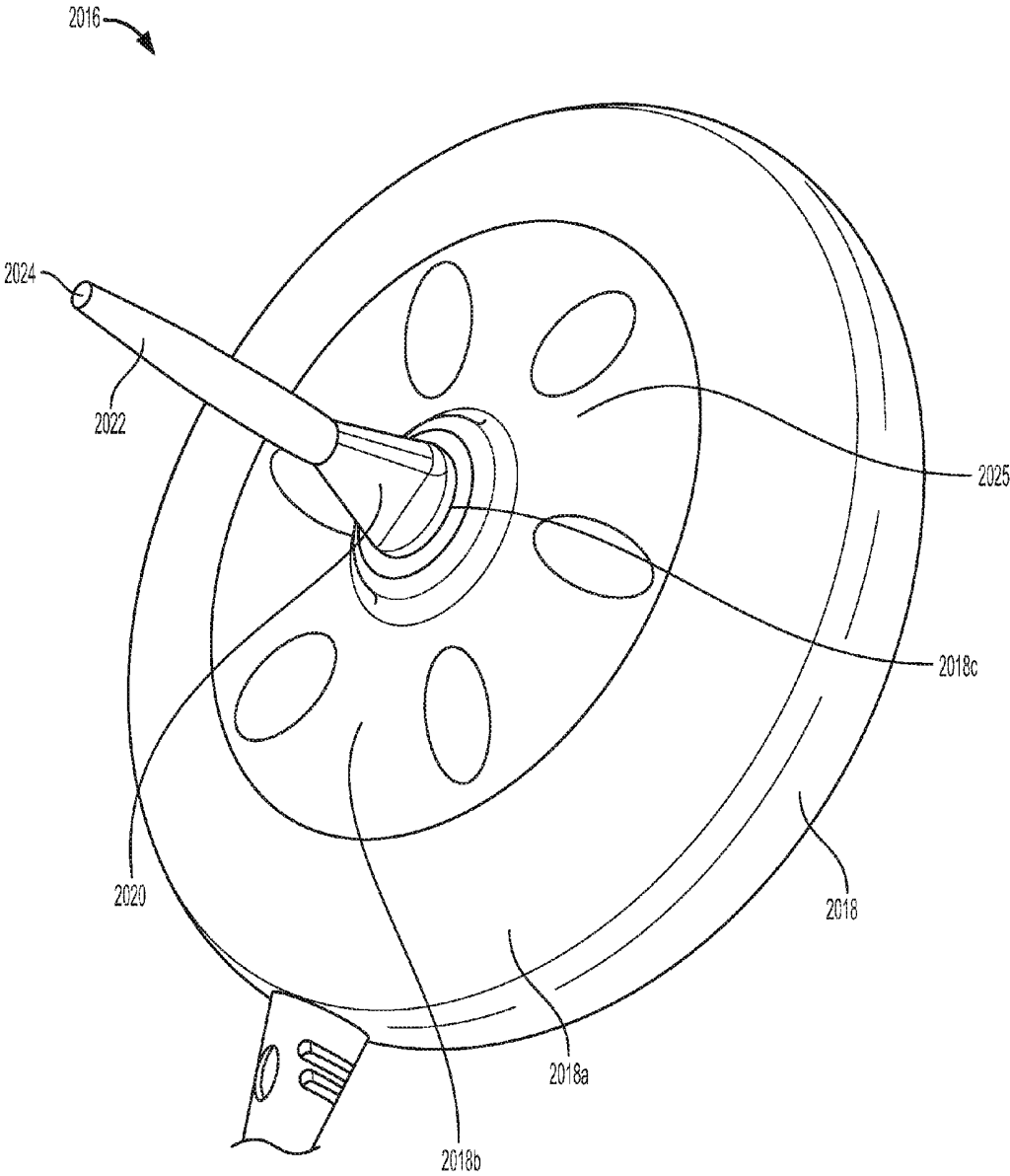

FIG. 39

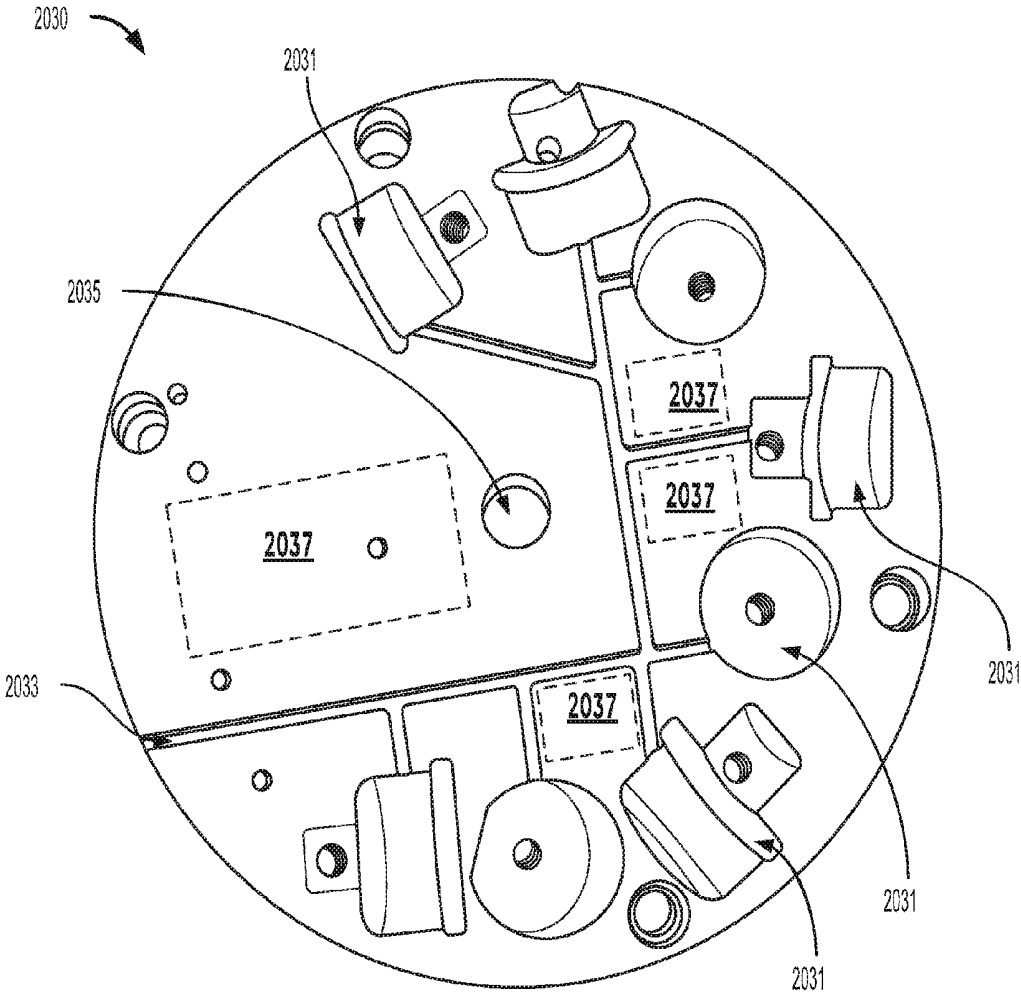

FIG. 39a

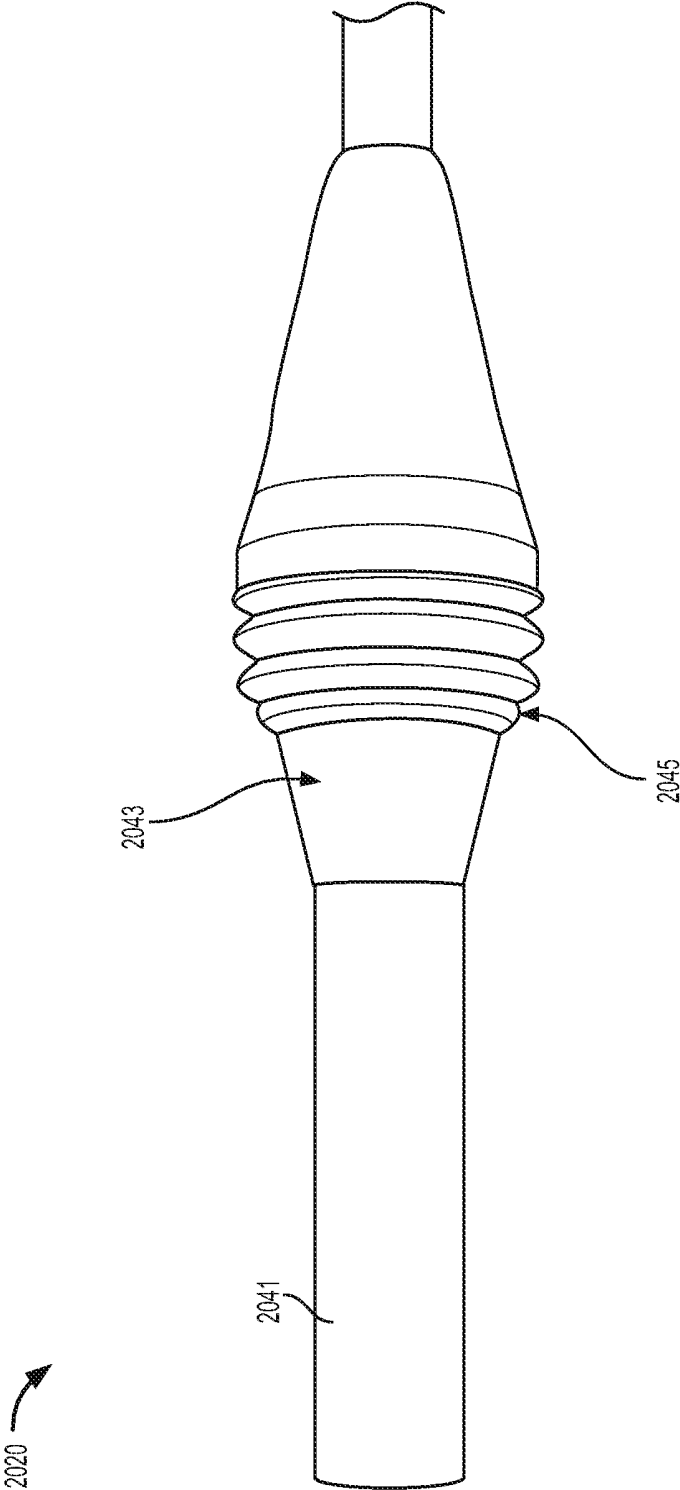

FIG. 39b

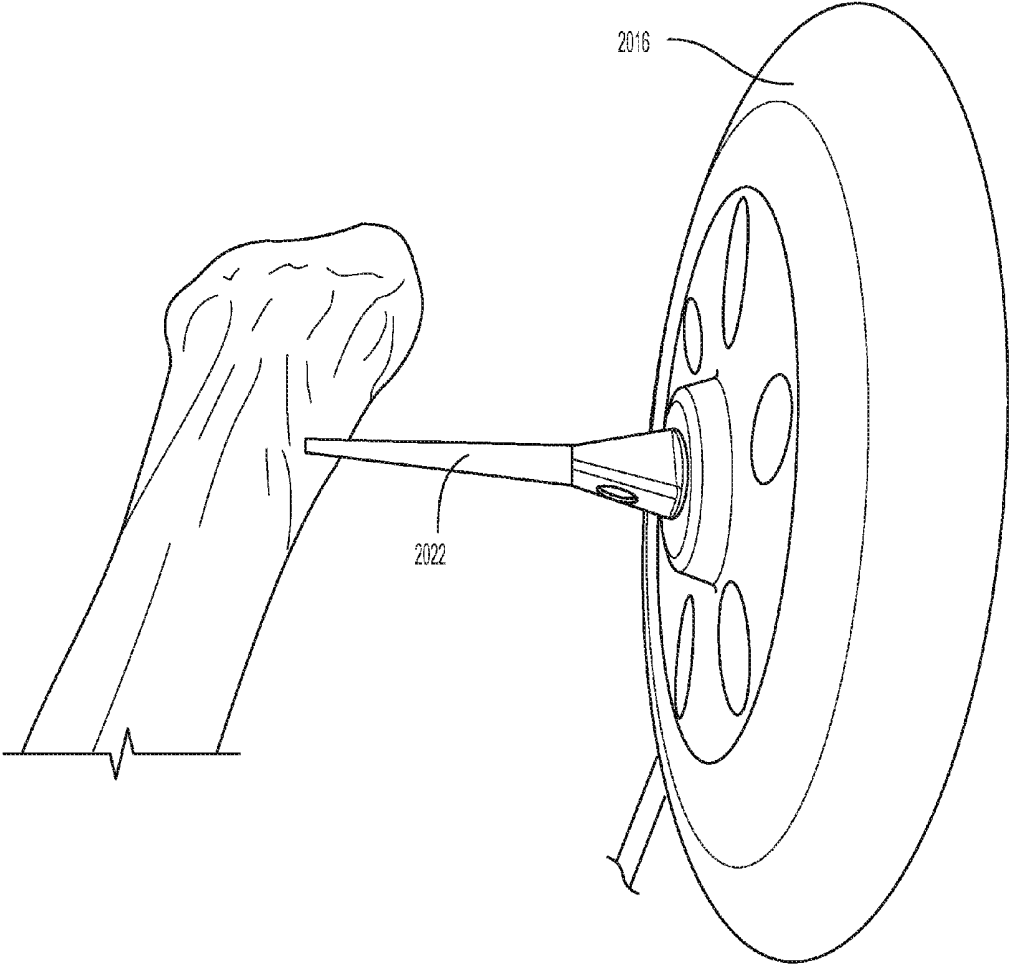

FIG. 40

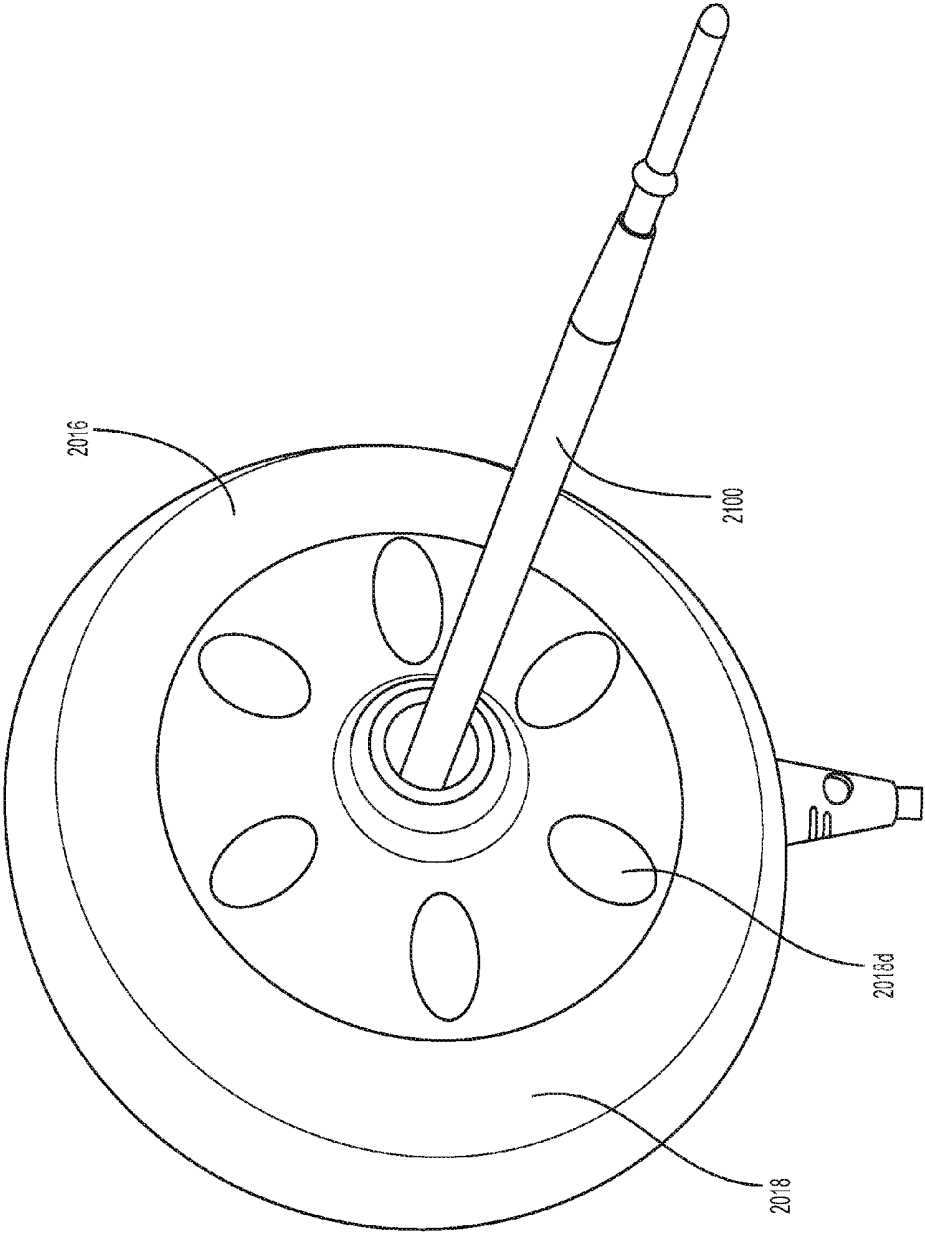

FIG. 41

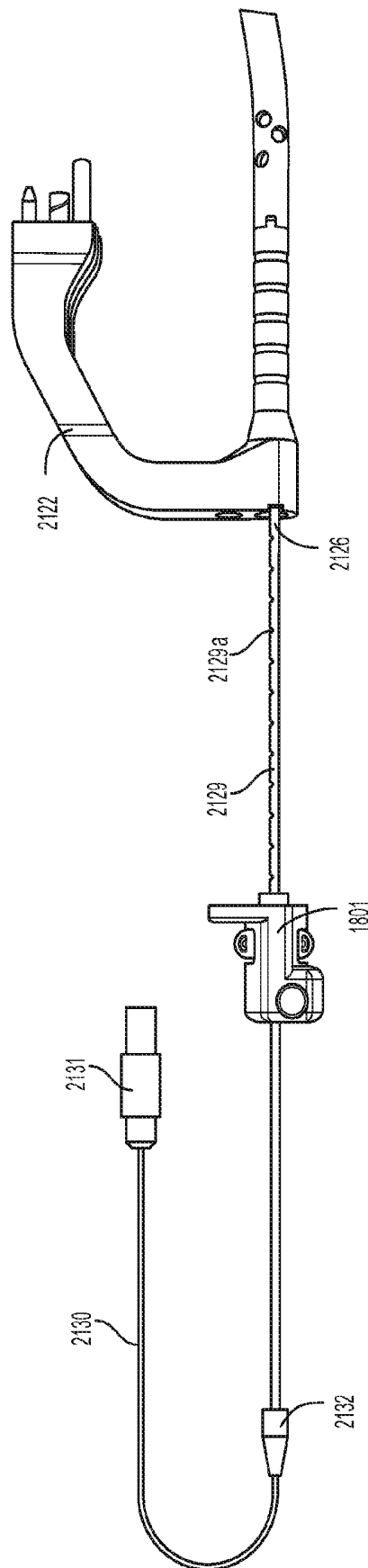

FIG. 42

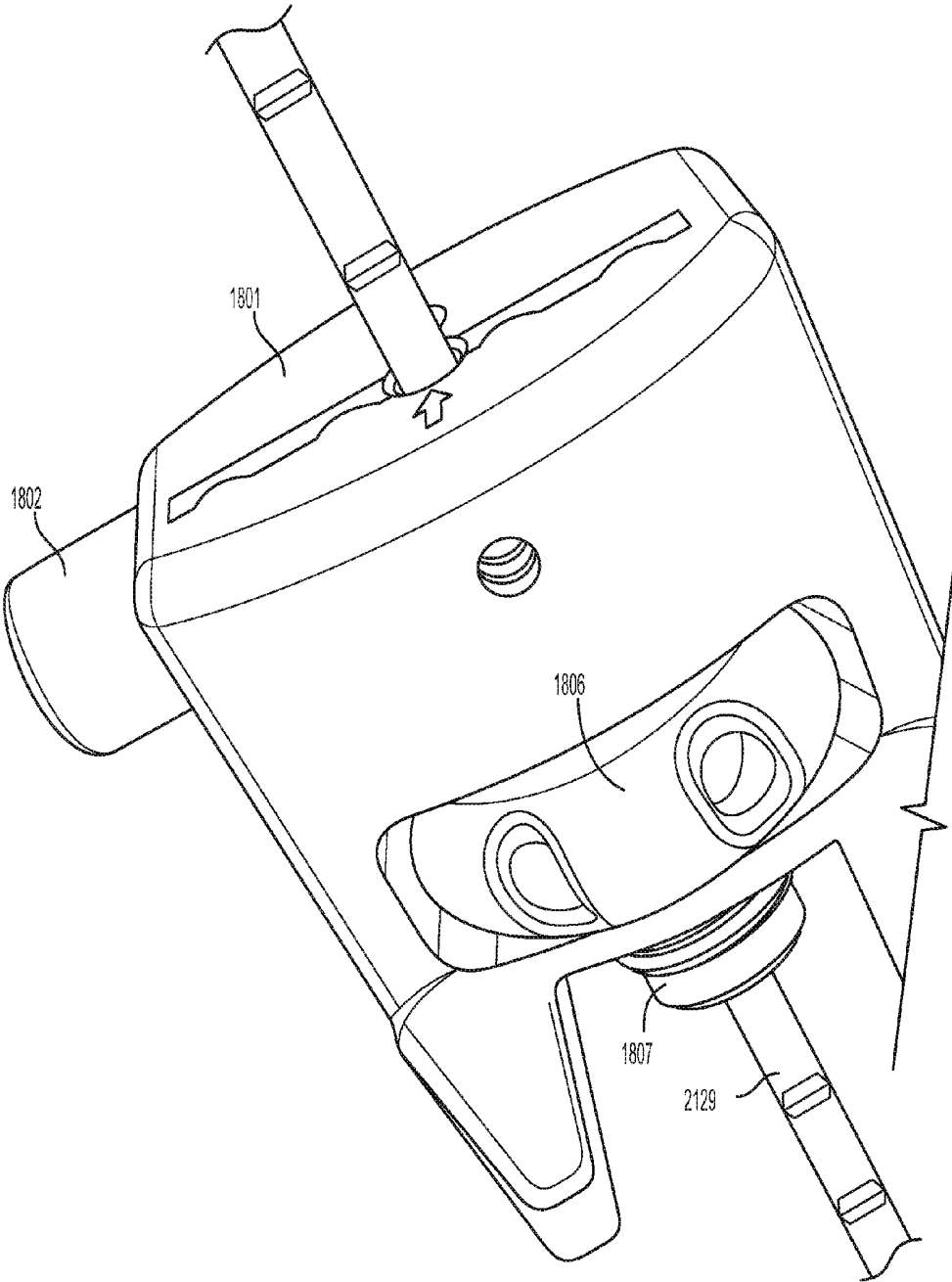

FIG. 43

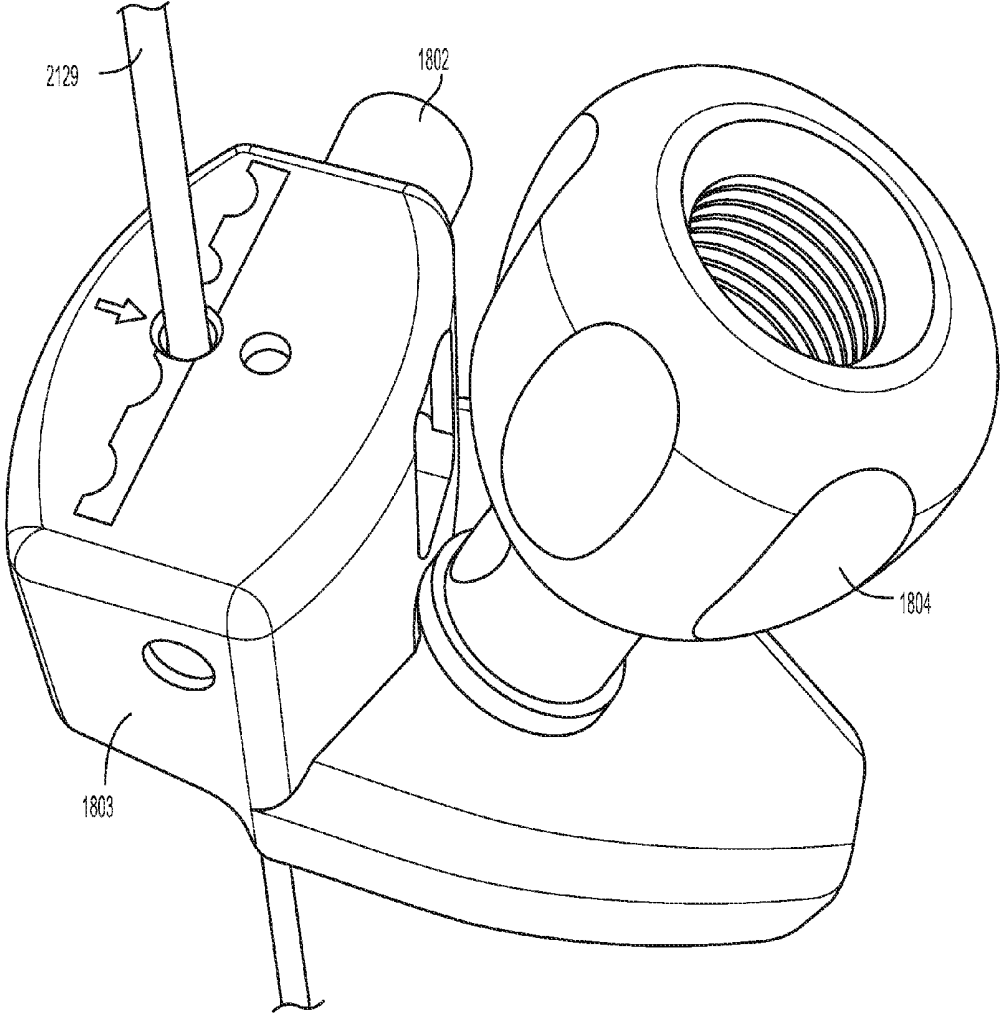

FIG. 44

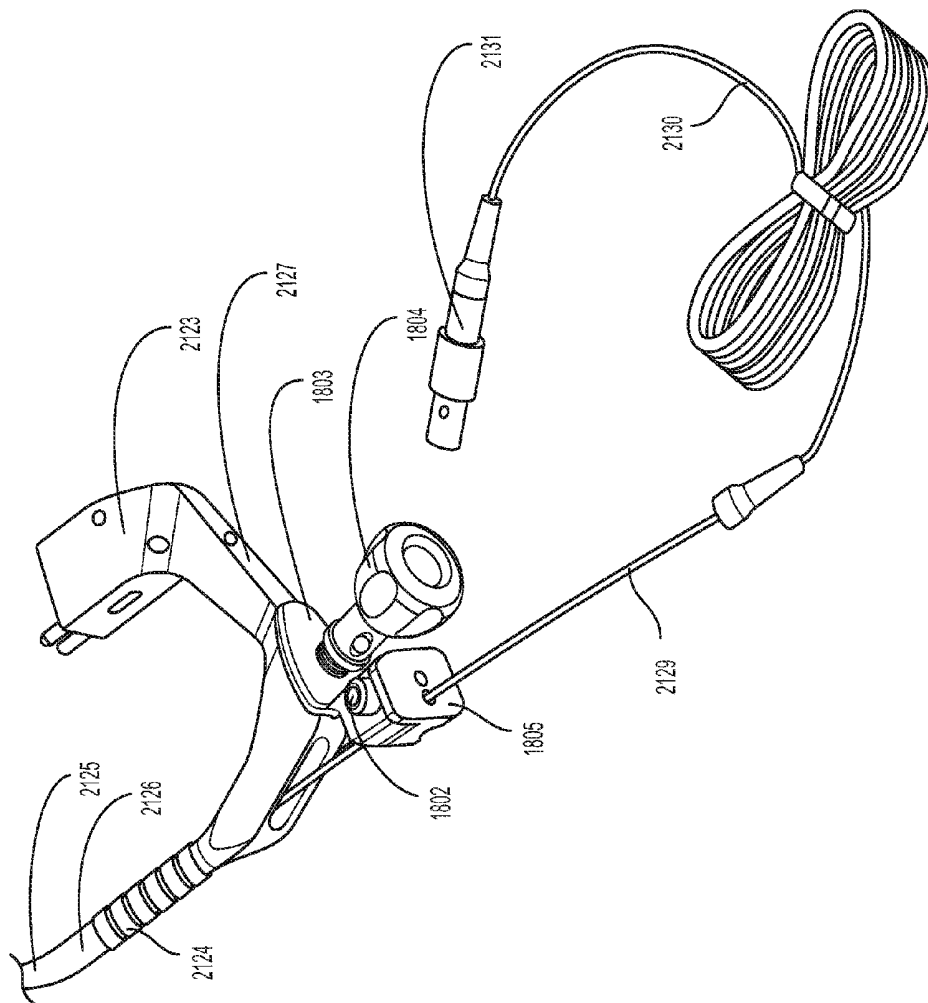

FIG. 45

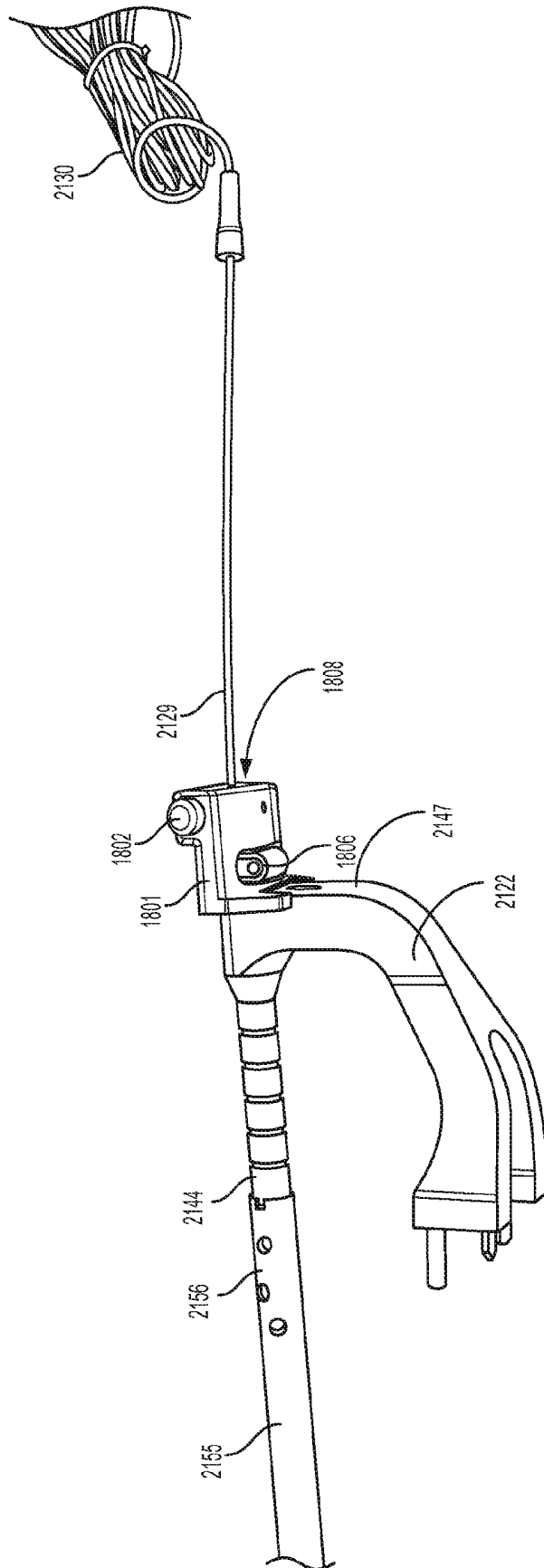

FIG. 46

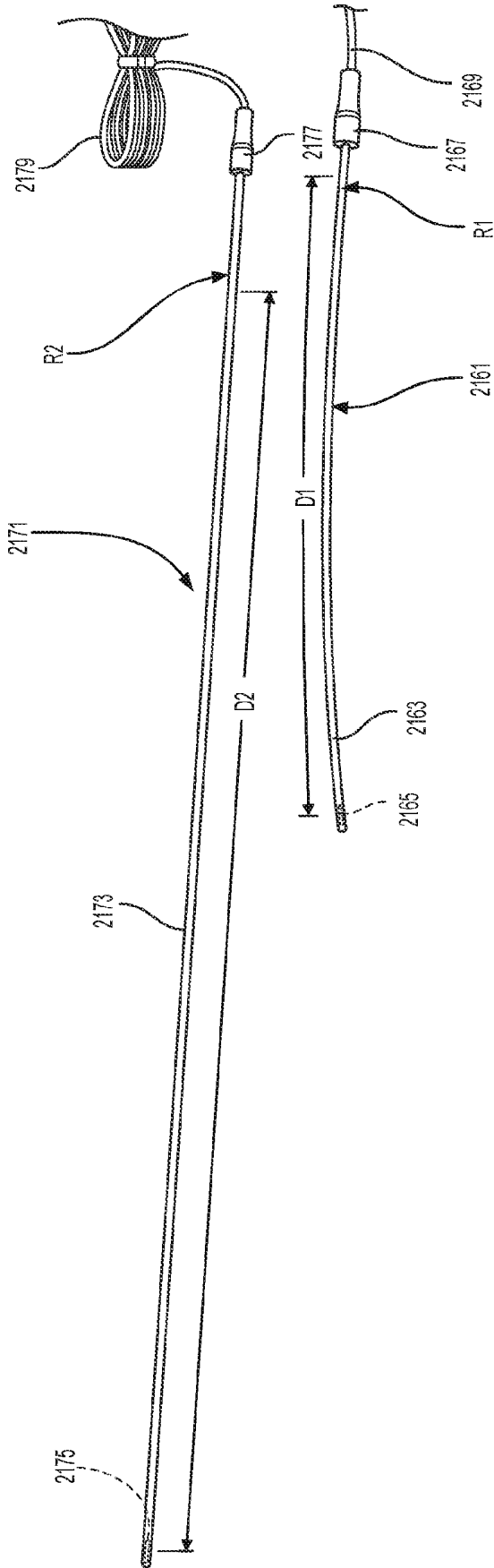

FIG. 47

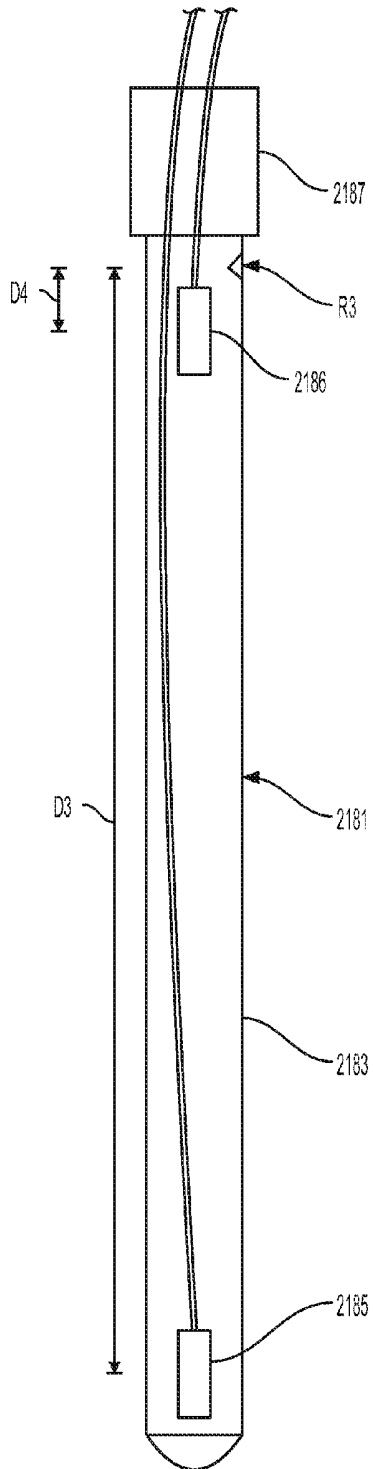

FIG. 48

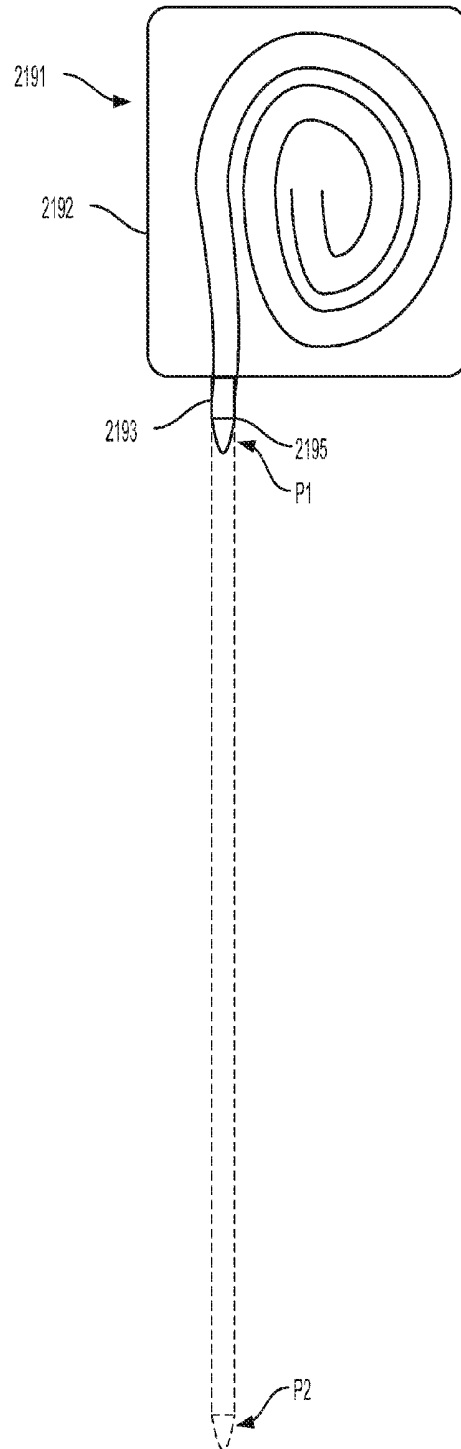

FIG. 49

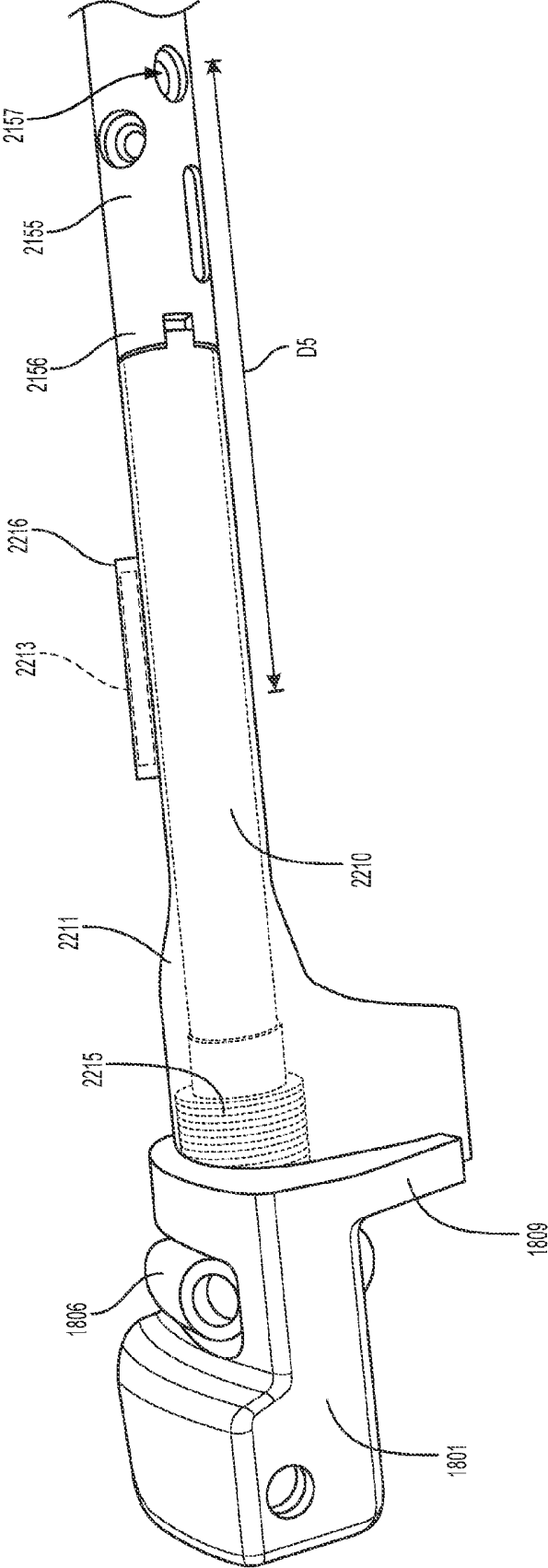
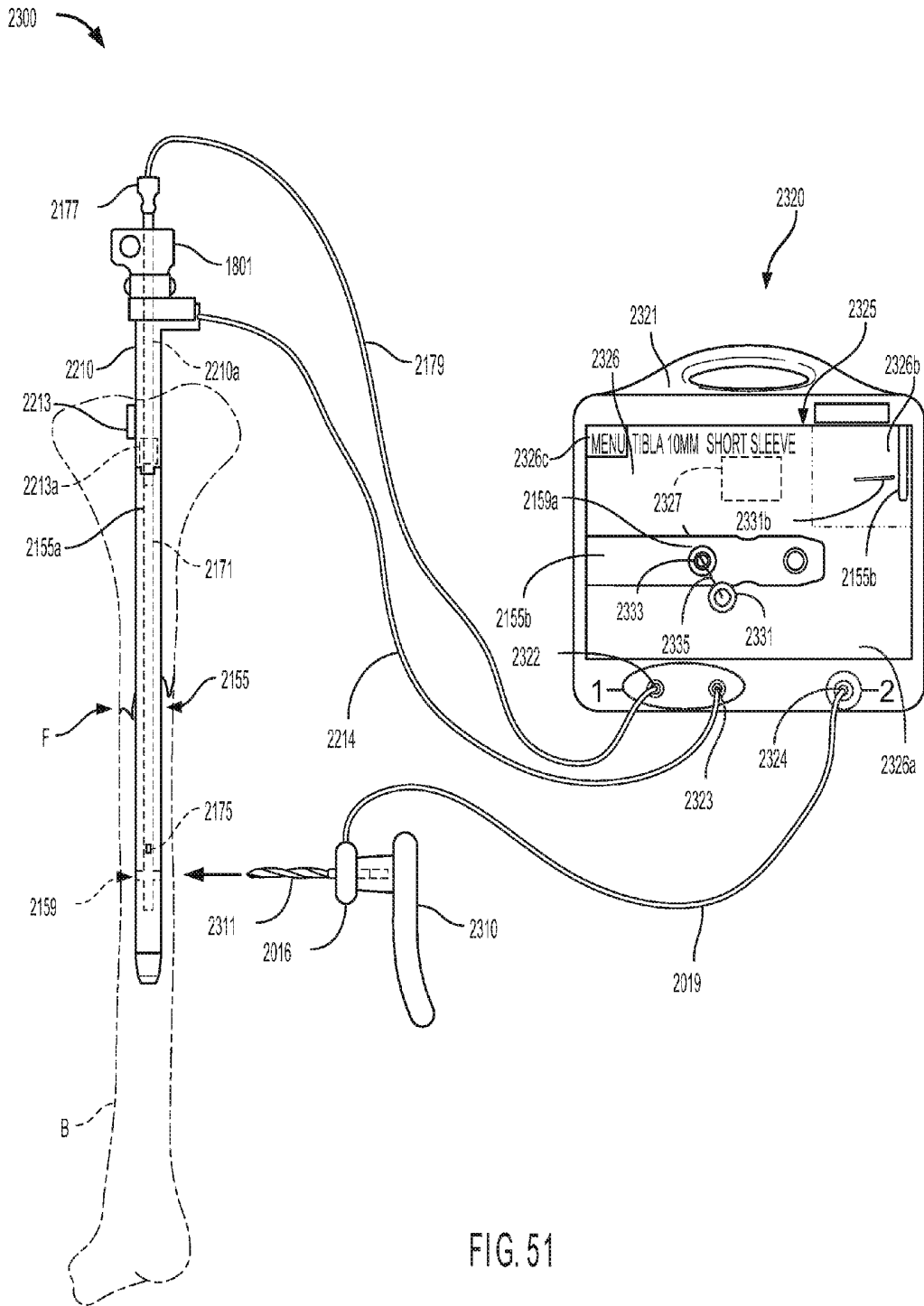

FIG. 50



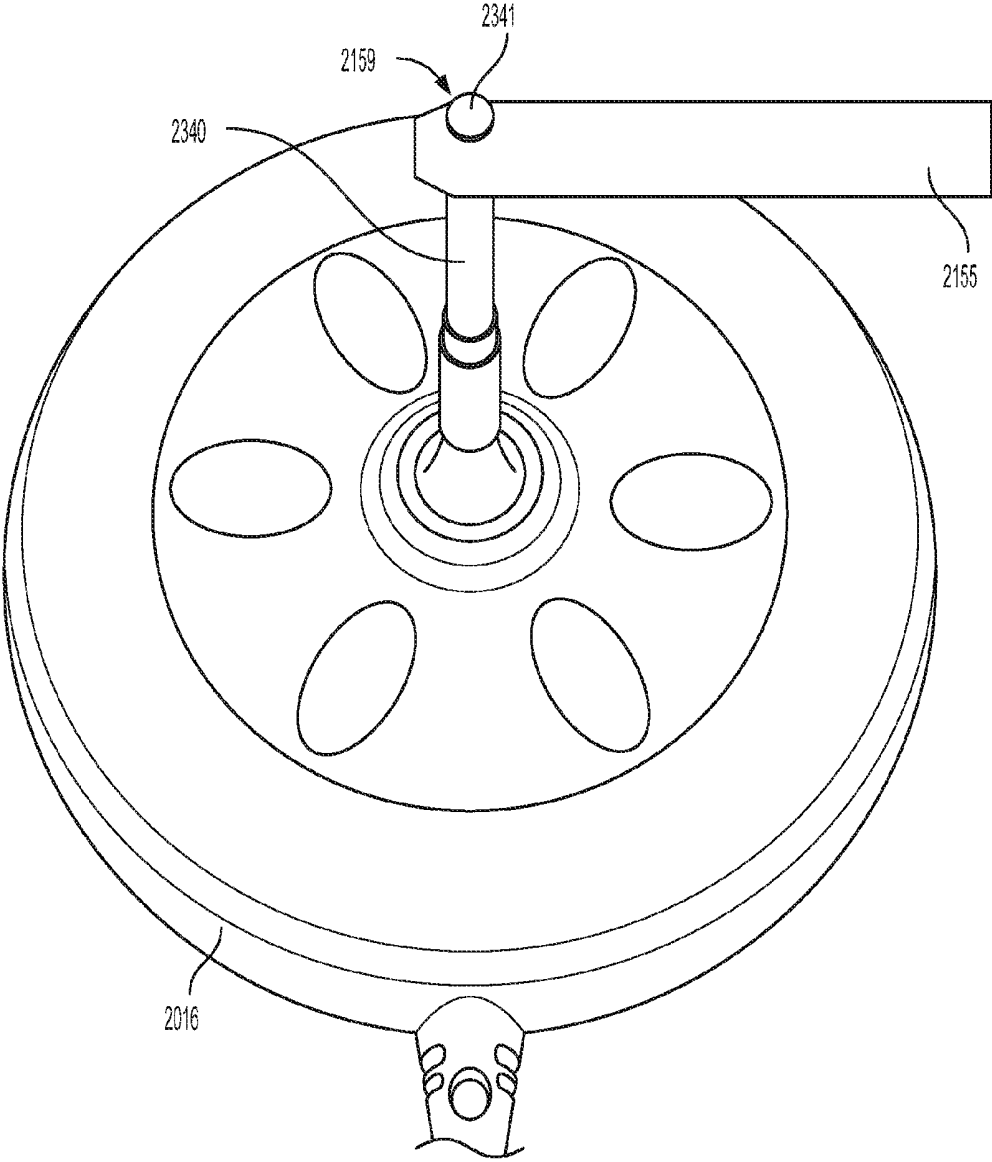

FIG. 52

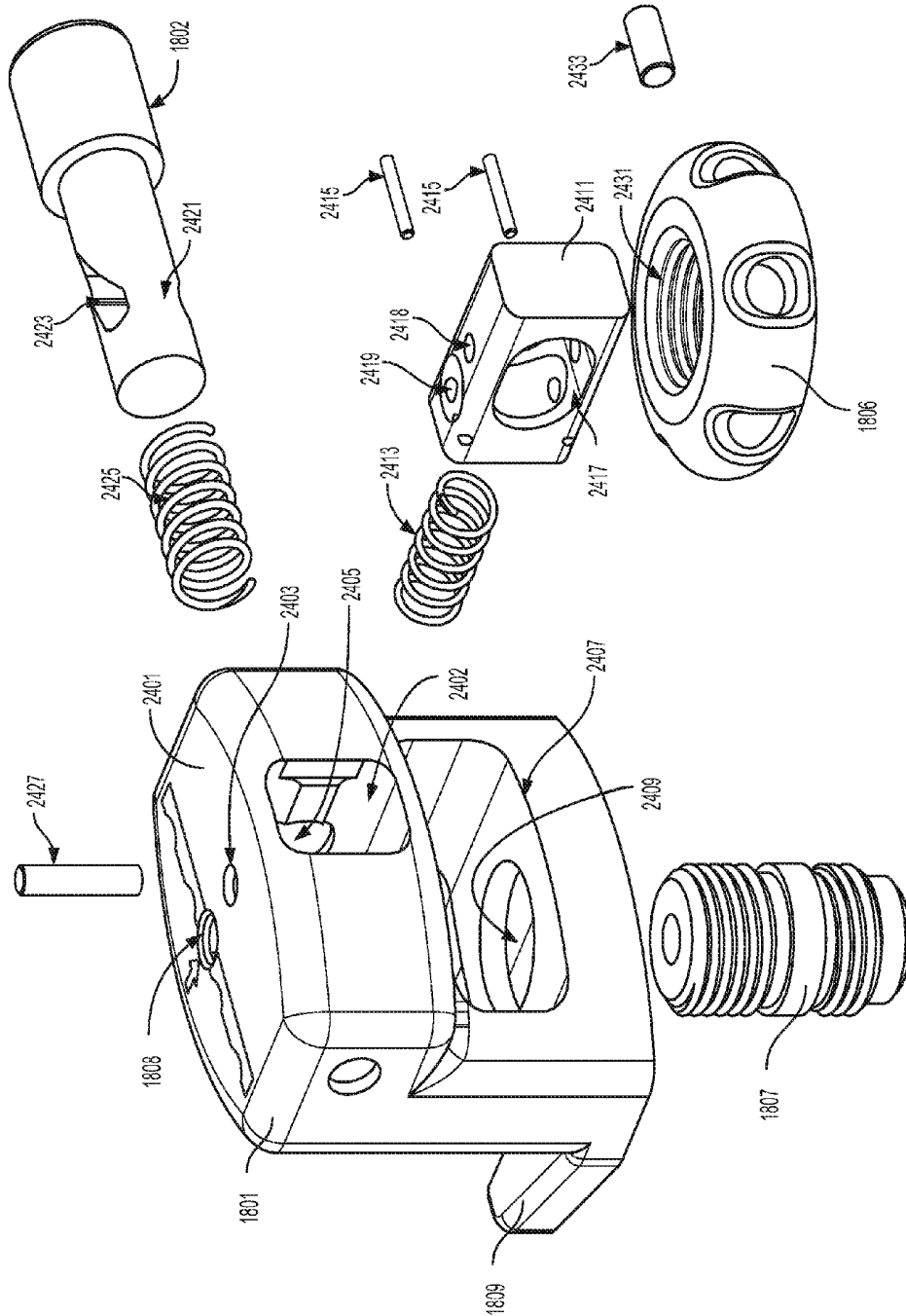

FIG. 53

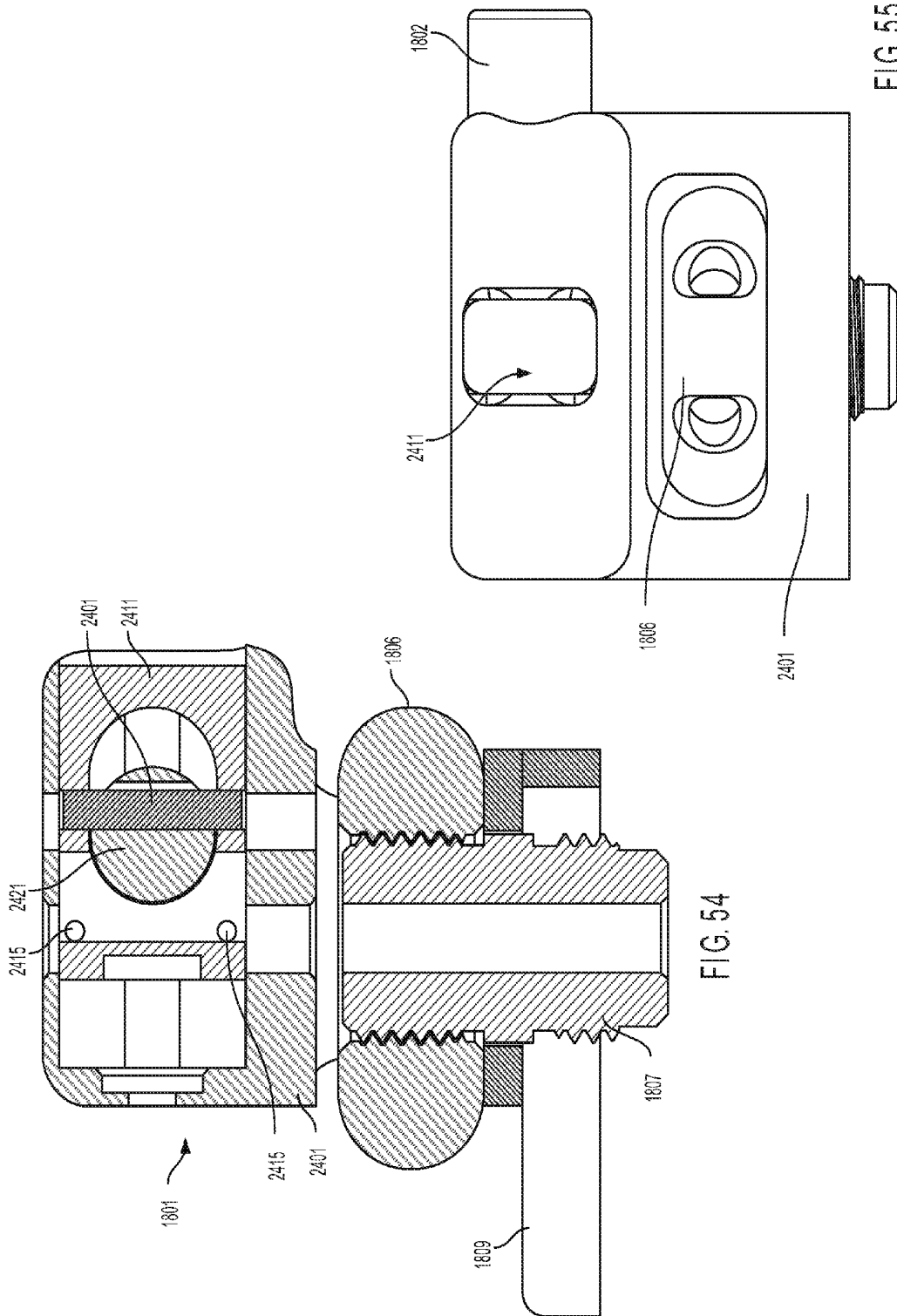

FIG. 54

FIG. 55

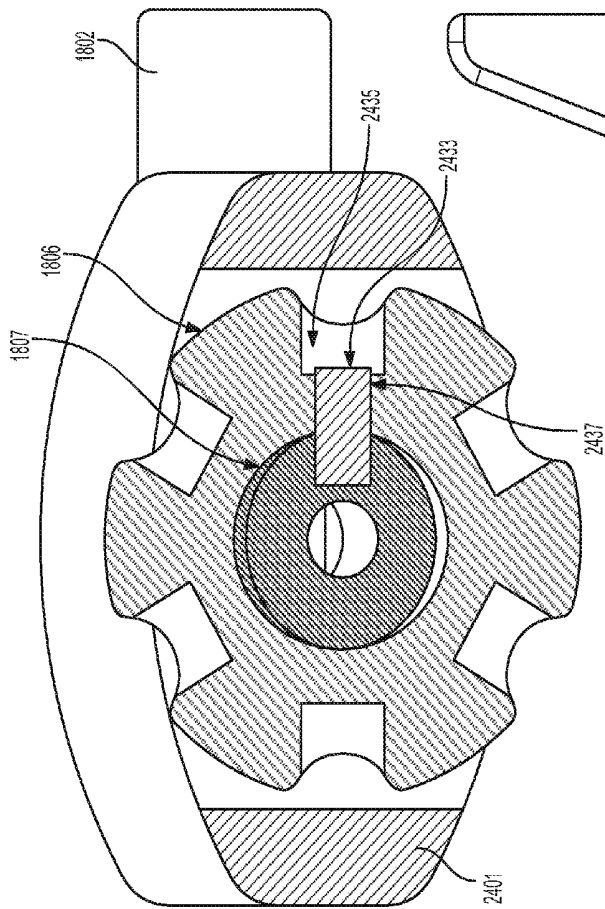

FIG. 56

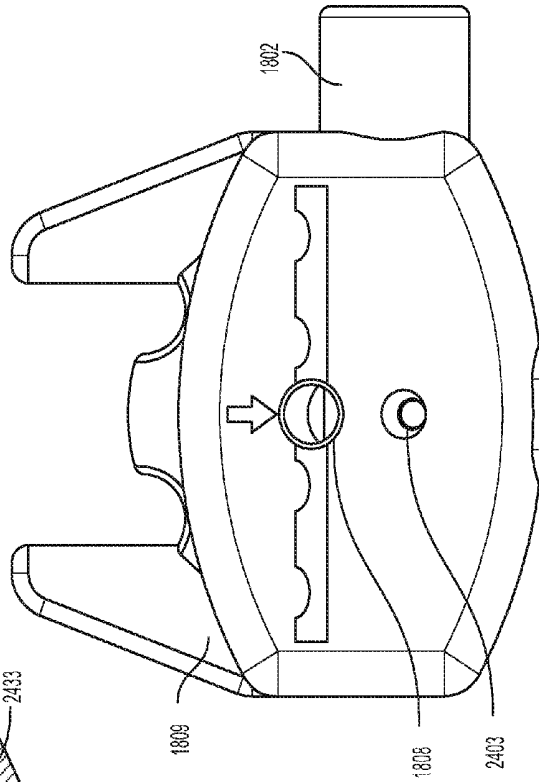

FIG. 57

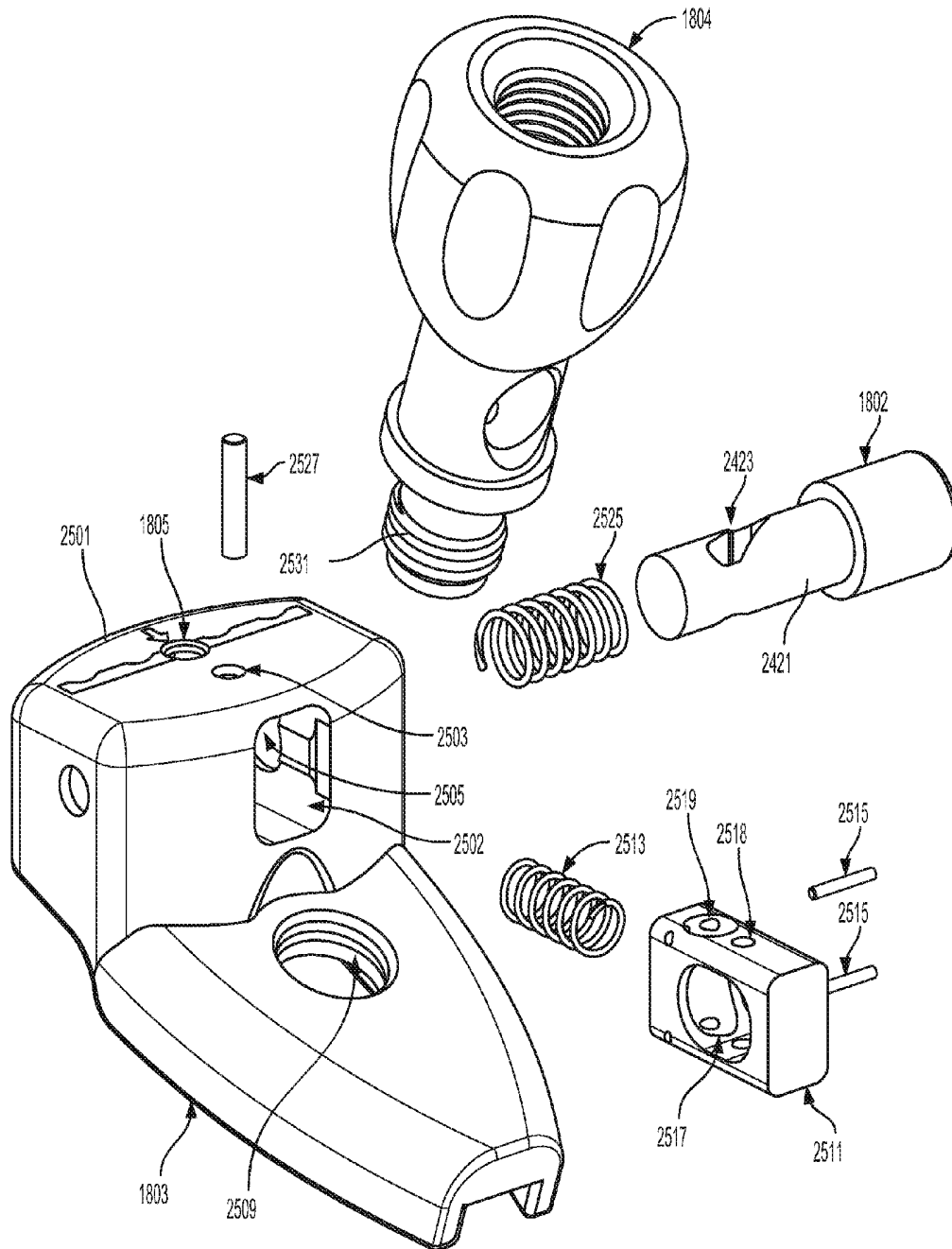

FIG. 58

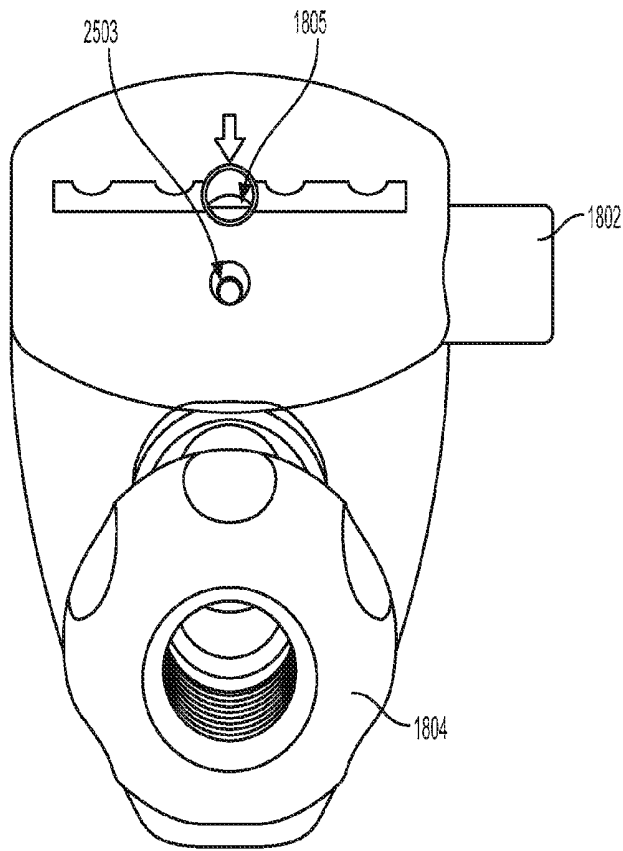

FIG. 59

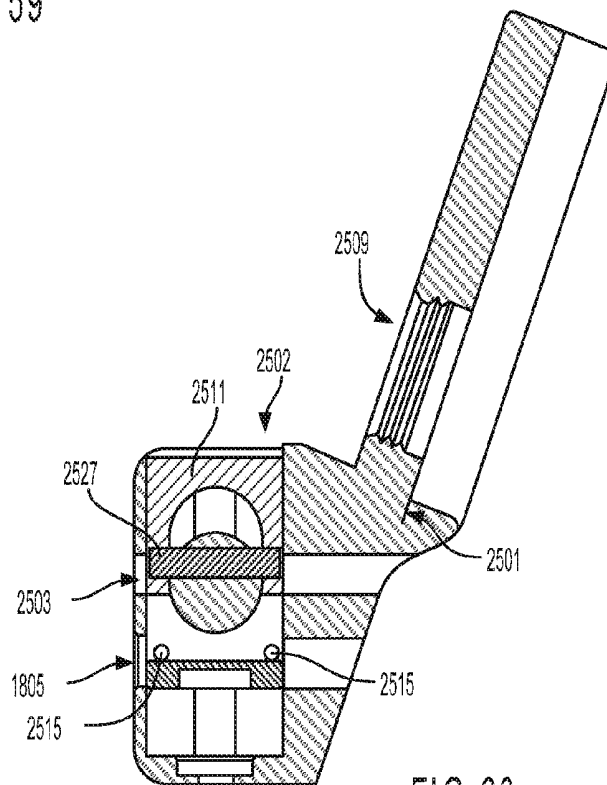

FIG. 60

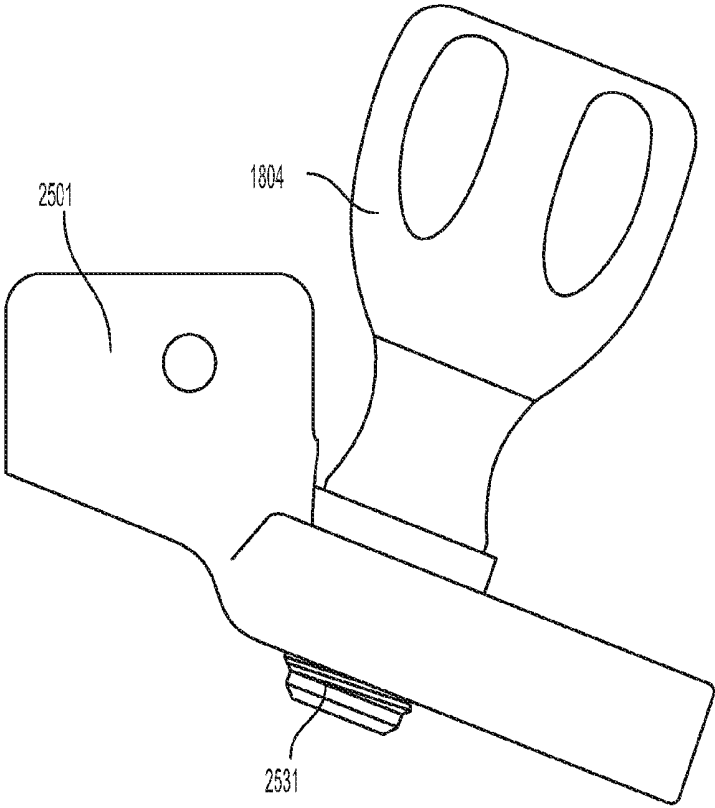

FIG. 61

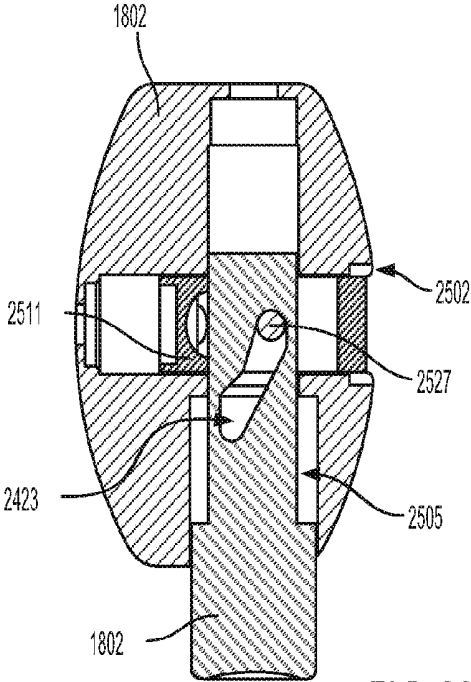

FIG. 62

SYSTEM AND METHOD FOR IDENTIFYING A LANDMARK

CROSS-REFERENCE TO RELATED APPLICATIONS

This application is a continuation of U.S. patent application Ser. No. 14/580,579, filed Dec. 23, 2014, now allowed, which is a divisional of U.S. patent application Ser. No. 12/768,689, filed Apr. 27, 2010, now U.S. Pat. No. 8,945,147, which is a continuation-in-part of U.S. application Ser. No. 12/547,716, filed Aug. 26, 2009, now U.S. Pat. No. 8,784,425, which claims priority from U.S. Provisional Application Ser. No. 61/173,069, filed on Apr. 27, 2009. The entire contents of the prior applications are incorporated herein by reference.

BACKGROUND

Technical Field

This disclosure relates to identification of blind landmarks on orthopedic implants.

Description of the Related Art

The interlocking nail has significantly widened the scope for intramedullary (IM) fixation of long bone fractures. Anchoring an IM nail to a bone makes the construct more stable longitudinally and stops rotation of the nail within the bone. A typical IM nail fixation surgery involves a combination of jigs, x-ray imaging, and manual “eye-balling” to locate and drill the distal screw holes and to install the screws in the screw holes.

In IM nail fixation surgery, an IM nail is inserted into the canal of a fractured long bone in order to fixate the fractured ends together. Typically, the proximal locking is performed first and is usually carried out with a jig. Nail deformation during intramedullary insertion, however, may make a jig inaccurate for the distal screws. In fact, the positioning of the distal locking screws and alignment of the drill for the drilling of the distal screw holes is the most time consuming and challenging step of the implantation procedure. The two main reasons for failure in distal locking are (1) incorrect entry point on the bone and (2) wrong orientation of the drill. If either of these problems occurs, then the drill will not go through the nail hole. An inaccurate entry point also compounds the problem as the rounded end of the drill bit often slips, damaging healthy bone rendering it difficult to place another drill hole next to the inaccurate hole. Inaccurate distal locking may lead to premature failure with breakage of the nail through the nail hole, breakage of the screw, or the breaking of the drill bit within the bone.

Manual techniques are the most common and accepted techniques for sighting the distal screw holes. The majority of manual distal targeting techniques employ a guide bushing or cylindrical sleeve that guides the drill. The mechanisms of aligning the guide bushing and keeping it in place differ. There are cases where the surgeons use a guide bushing cut in half longitudinally or a full guide bushing to help steady the drill bit. In either situation, the surgeon will incise the patient and insert the drill through the incision. Manual techniques are based primarily on the surgeon’s manual skill and make use of radiographic x-ray imaging and mechanical jigs.

Another method for achieving this on long nails is by using a technique called “perfect circles” with the aid of a C-shaped arm. This is where the patient and the C-arm are oriented such that when viewing the implant fluoroscopically the hole through which the screw is to pass appears to

be in the shape of a circle. If the C-arm is not perpendicular to the hole then the hole appears oblong or even absent.

A need exists for an improved system and method for accurately and dependably targeting landmarks of a medical implant. Further, a need exists for accurately positioning the distal locking screws and aligning the drill for the drilling of the distal screw holes. Still further, a need exists for an improved system for targeting landmarks whereby the components may be easily sterilized or autoclaved and reused again.

SUMMARY

In a general aspect, a system for identifying a landmark includes a field generator for generating an electromagnetic field and a landmark identifier. The field generator and the landmark identifier are disposed in a common housing, and the field generator, the landmark identifier, and the common housing are autoclavable. The system also includes an orthopaedic implant located within the electromagnetic field, and the orthopaedic implant includes at least one landmark. A first magnetic sensor is spaced apart from the at least one landmark by a set distance, and a processor compares sensor data from the first sensor and landmark identifier and uses the set distance to calculate the position of the landmark identifier relative to the at least one landmark.

Implementations may include one or more of the following features. For example, the landmark is selected from the group consisting of a structure, a hole, a void, a boss, a channel, a detent, a flange, a groove, a member, a partition, a step, an aperture, a bore, a cavity, a dimple, a duct, a gap, a notch, an orifice, a passage, a slit and a slot. The orthopaedic implant may be an intramedullary nail. The orthopaedic implant has an outer surface and an inner surface forming a cannulation, and the first sensor is mounted to a distal portion of a probe that extends into the cannulation. The common housing in some implementations also accommodates a drill motor, the drill motor being coupleable to a drill bit. The housing may include a drill sleeve. The housing may be disk-shaped. The drill extends normally outward from the disk-shaped housing. The system can also include an insertion handle removably coupled to the orthopaedic implant. An adjustable stop can be coupled to the implant and includes a slot through which the probe extends. The adjustable stop includes a clamp mechanism to hold the probe in a fixed position. The probe may include a plurality of spaced apart markings, and the adjustable stop includes a clamp mechanism to hold the probe in a fixed position on a marking or between two markings.

In another general aspect, identifying a landmark includes providing an orthopaedic implant assembly having an orthopaedic implant having at least one landmark, implanting the orthopaedic implant assembly in a patient, and placing a probe in the implant. The probe includes an electromagnetic sensor. Identifying the landmark further includes generating an electromagnetic field that encompasses the sensor and landmark, identifying the at least one landmark using a landmark identifier, installing a transfixion element in the at least one landmark, and removing the probe. The landmark identifier is disposed in an autoclavable housing.

Implementations may include one or more of the following features. For example, the landmark is selected from the group consisting of a structure, a hole, a void, a boss, a channel, a detent, a flange, a groove, a member, a partition, a step, an aperture, a bore, a cavity, a dimple, a duct, a gap, a notch, an orifice, a passage, a slit and a slot. The ortho-

paedic implant may be an intramedullary nail. The orthopaedic implant has an outer surface and an inner surface forming a cannulation, and identifying a landmark further includes mounting the first sensor to a distal portion of a probe that extends into the cannulation. The field generator and landmark identifier are disposed in a common autoclavable housing and identifying the landmark also includes autoclaving the housing. The field generator and landmark identifier are disposed in a common autoclavable housing that may also accommodate a drill motor, the drill motor being coupled to a drill bit, and identifying a landmark further comprises autoclaving the housing and drill. The housing may include a drill sleeve. The housing may be disk-shaped. Identifying a landmark also includes removably coupling an insertion handle to the orthopaedic implant and/or clamping the probe in a fixed position. The probe comprises a plurality of spaced apart markings and the probe is clamped in a fixed position on a marking or between two markings.

In another general aspect, a system for identifying a landmark includes an autoclavable housing accommodating a field generator for generating an electromagnetic field, a landmark identifier, and a drill motor. An orthopaedic implant is located within the electromagnetic field and the orthopaedic implant has at least one landmark. A probe includes a first electromagnetic sensor and is placed within the orthopaedic implant and spaced apart from the at least one landmark by a set distance. A processor is also included for comparing sensor data from the first sensor and landmark identifier and for using the set distance to calculate the position of the landmark identifier relative to the at least one landmark. The first electromagnetic sensor is coupled to the processor via the probe.

In another general aspect, a kit for identifying landmarks on medical implants includes an autoclavable housing accommodating a field generator for generating an electromagnetic field, and a landmark identifier. A plurality of orthopaedic implants are also included, one of which is located within the electromagnetic field. Each orthopaedic implant includes at least one landmark. A plurality of probes, each including an electromagnetic sensor, is included. One of the probes selected based on a size of the implant disposed in the electromagnetic field. The selected probe is placed within the implant in the electromagnetic field and spaced apart from the at least one landmark by a set distance. A processor is included for comparing sensor data from the first sensor and landmark identifier and for using the set distance to calculate the position of the landmark identifier relative to the at least one landmark, wherein the first electromagnetic sensor is coupled to the processor via the probe.

In another general aspect, a system for targeting a landmark of an orthopaedic implant includes an autoclavable housing, a field generator disposed within the housing for generating an electromagnetic field, a first electromagnetic sensor for disposition at a set distance from the landmark that generates sensor data in response to the generated electromagnetic field, and an element removably coupled to the housing, the element defining a longitudinal axis that represents one axis of the generated magnetic field. The system is configured to use the one axis of the generated electromagnetic field to determine the position of the element relative to the landmark. Optionally, if the longitudinal axis of the element is offset from the axis of the field, one can compensate this offset within the software.

Implementations may include one or more of the following features. For example, the system can include a first

probe having a proximal portion and a distal portion, the first electromagnetic sensor disposed on the distal portion of the probe, a retractable probe including the first electromagnetic sensor, or a retractable probe including the first electromagnetic sensor and a housing containing at least a portion of the retractable probe. A second electromagnetic sensor disposed on the proximal portion of the first probe can also be included. The system can include a second probe having a proximal and a distal portion and a third electromagnetic sensor disposed on the distal end of the second probe, where the second probe is longer than the first probe. The system can also include a processor for comparing the sensor data from the first electromagnetic sensor and the element and using the set distance to calculate the position of the element relative to the landmark. The system can include an adjustable stop that is connectable to the orthopedic implant. The adjustable stop can include a slot through which the first or the second probe extends and includes a clamping mechanism to hold the first or second probe in a fixed position. The first or the second probe can include a plurality of spaced apart indicators such that the clamping mechanism can be selectively set to hold the first or second probe in a fixed position at an indicator or between indicators. A handle can be removably coupled to the orthopedic implant. The autoclavable housing can be disk-shaped. The element can include one of a drill guide, a drill sleeve, a drill, a drill nose, a drill barrel, a drill chuck, and a fixation element. The orthopedic implant can include one of an intramedullary nail, a bone plate, a hip prosthetic, a knee prosthetic, a spinal prosthetic, and a shoulder prosthetic. The first or the second probe can be coiled or bent prior to placement into the orthopedic implant. The first electromagnetic sensor includes a proximal end and a distal end. The distal end of the first electromagnetic sensor is connected to a proximal end of the orthopedic implant such that the first electromagnetic sensor is spaced apart a set distance from at least one landmark disposed in a proximal region of the orthopedic implant. At least the housing and the element are reusable. The housing is made from one of ceramic, silicone, polypropylene (PP), polycarbonate (PC), polymethylpentene (PMP), PTFE resin, or polymethyl methacrylate (PMMA or acrylic).

In another general aspect, a method includes exposing a landmark identifier to a sterilization process, the landmark identifier comprising a mounting structure comprising elements that are configured to receive induction coils of an electromagnetic field generator. The elements are disposed on the mounting structure at locations and orientations relative to each other. Exposing the landmark identifier to the sterilization process does not substantially alter the locations and orientations of the plurality of elements relative to each other.

Implementations may include one or more of the following features. For example, the method further includes using the landmark identifier to target a landmark of an orthopaedic implant. Targeting may include placing the field generator within an operating range of a sensor and using a display of a targeting system for positioning the landmark identifier in a predetermined position relative to the landmark.

In another general aspect, a method of making a landmark identifier includes forming elements at locations in a mounting structure, securing electromagnetic induction coils at orientations in the elements, forming a hole through the mounting structure, securing a coupling member to the mounting structure, covering the mounting structure and the electromagnetic induction coils with a third autoclavable material, and, optionally, applying a fourth autoclavable

material over an exterior surface of the third autoclavable material. The mounting structure comprises a first dimension stable autoclavable material. The coupling member has a through hole that is aligned with the hole formed through the mounting structure when the coupling member is secured to the mounting structure and the coupling member comprising a second dimension stable autoclavable material. The third and fourth autoclavable materials may also be dimension-stable materials.

Implementations may include one or more of the following features. For example, at least one of a sleeve or sleeve attachment is removably coupled to the coupling member. The sleeve/sleeve attachment is preferably made of dimension-stable autoclavable materials with sufficient strength. The method also includes forming one or more apertures in the mounting structure and disposing at least one of a hollow material and a foam material, preferably closed cell foam, in the one or more apertures. A gripping surface is formed on an external surface of the landmark identifier and the gripping surface includes at least one of a surface texture and a surface depression.

In another general aspect, an apparatus for targeting a landmark of an orthopaedic implant includes an insertion handle removably attachable to the orthopaedic implant, an adjustable stop comprising an actuator, and a probe comprising a sensor and a plurality of markings to assist in placing the probe and sensor at a desired location with respect to the orthopaedic implant.

Implementations may include one or more of the following features. For example, the adjustable stop includes a mating portion such that when the stop is connected to the insertion handle, the stop is located or fixed within three degrees of freedom. The insertion handle is attached to the orthopaedic implant through use of a cannulated bolt.

In another general aspect, a kit for targeting a landmark of an orthopaedic implant includes a proximal targeting probe comprising a tape body and a sensor included within or on the tape body at a predetermined distance from a reference point of the tape body. The proximal targeting probe includes a first indicator that indicates that the proximal targeting probe is to be used for targeting proximal landmarks of an orthopaedic implant. The kit also includes a distal targeting probe that includes a tape body that is longer than the tape body of the proximal targeting probe and a sensor included within or on the tape body of the distal targeting probe at a second predetermined distance from a second reference point of the target body of the distal targeting probe. The distal targeting probe includes a second indicator that indicates that the distal targeting probe is to be used for targeting distal landmarks of the orthopaedic implant.

Implementations may include one or more of the following features. For example, the first indicator includes a color-coded grip and the second indicator includes a color-coded grip that is a different color than the first indicator. The first indicator includes a color-coded grip and the second indicator includes a color-coded grip that is a different color than the first indicator. The proximal targeting probe includes a cable for carrying a signal from the sensor included within or on the tape body of the proximal targeting probe to a control unit, and the distal targeting probe includes a second cable for carrying a second signal from the sensor included within or on the tape body of the distal targeting probe to the control unit. The sensors included within or on the tape bodies of the proximal and distal targeting probes are connected to one or more Programmable Read-Only Memory microchip that identifies whether

the proximal and distal targeting probes are used for proximal or distal targeting. The tape bodies of the proximal and distal targeting probes include one or more bends to bias at least a portion of the tape bodies against a wall of the orthopaedic implant.

In another general aspect, a probe for use in targeting a landmark of an orthopaedic implant includes a housing, a retractable or extensible body disposed within the housing. The body is configured to form a generally straight shape when extended from the housing. A sensor is disposed within the body and is positionable at a first location for targeting a proximal landmark of the orthopaedic implant. The sensor is positionable at a second location for targeting a distal landmark of the orthopaedic implant. The body comprises one of layered, flexible stainless steel spring bands, resilient plastics, or rubber tubing or sheeting. The body includes a plurality of nested segments of tubing that can extend and retract by sliding within adjacent tubing segments.

In another general aspect, an apparatus for targeting a landmark located in a proximal end of an orthopaedic implant includes an insertion handle and a sensor disposed within or on the insertion handle at a predetermined distance from a proximal locking aperture formed in the orthopaedic implant when the insertion handle is attached to the orthopaedic implant. The sensor is passive or electrically powered. The sensor is mounted in a housing that is unitary or integral with the insertion handle.

In another general aspect, a landmark identifier for use in a surgical targeting system includes a mounting structure that has elements that are configured to receive induction coils of an electromagnetic field generator. The elements are disposed on the mounting structure at locations and orientations relative to each other. The landmark identifier also includes at least one covering formed over the mounting structure. In use, the locations and orientations of the elements relative to each other remain substantially unaltered after exposure to one or more sterilization processes.

Implementations may include one or more of the following features. For example, the mounting structure defines one or more openings and a hollow insert or a closed cell foam material is disposed in the opening(s). The field generator includes at least one of a sleeve and sleeve attachment having a longitudinal axis aligned with the center of gravity of the landmark identifier. The mounting structure is formed or molded from a dimension stable autoclavable material. The mounting structure includes a reinforced epoxy laminate. The field generator includes electromagnetic induction coils mounted in the elements at the locations and orientations relative to each other. The field generator includes at least one covering comprises a first covering formed from an autoclavable material and the first covering is disposed over each of the elements. The first covering comprises a silicone material. The field generator includes a coupling member attached or molded to the mounting structure and configured to receive a removable sleeve or sleeve attachment, wherein the coupling member and the sleeve/sleeve attachment comprise dimension stable autoclave materials. The sleeve and the sleeve attachment comprise a frustoconical portion.

In another general aspect, a method of locking an orthopaedic implant having at least one hole using an electromagnetic field generator includes aligning a drill guide tip, preferably a serrated tip, over the one hole of the orthopaedic implant using the electromagnetic field generator, making an incision into soft tissue, inserting the drill guide tip through the incision against the bone, pivoting the drill guide tip

against the bone to align the axis of the drill guide with an axis of the hole, and drilling through the bone. The method may further include engaging a fastener with the bone through the hole of the orthopaedic implant to lock the orthopaedic implant to the bone. Engaging the fastener with the bone includes removing a drill sleeve and sleeve attachment from the coupling member, coupling or inserting, a driver with a fastener through the coupling member, aligning an axis of the fastener and/or driver with the axis of the hole of the orthopaedic implant, and driving the fastener into the hole to lock the orthopaedic implant to the bone.

Implementations may include one or more of the following features. For example, the method may further include using an indicator coupled with a driver for inserting the fastener into bone at a desired depth. The indicator includes a laser etching corresponding to the actual or calculated dimension or height of a fastener head and a circumferential groove formed at the base of the head. The indicator is configured to indicate the position of the fastener head relative to a bone surface by the relative location of a reference portion of the indicator and the circumferential groove.

The disclosed methods and apparatuses include several advancements. First, the disclosed methods and apparatuses can operate independently of fluoroscopy and eliminate the necessity of X-ray devices for targeting of transfixion elements, thereby reducing the exposure of users and patients to radiation. Second, disclosed methods and apparatuses allow a user to lock the driving-end of the implant before locking the non-driving end of the implant. In other words, the disclosed methods and apparatuses do not require use of an implant cannulation that requires proximal locking prior to distal locking.

Other advantages and features will be apparent from the following detailed description when read in conjunction with the attached drawings.

BRIEF DESCRIPTION OF THE DRAWINGS

FIG. 1 illustrates a system for identifying a landmark. FIG. 2 is a sectional view of an orthopaedic implant of FIG. 1.

FIG. 3 is a partial sectional of the implant of FIGS. 1 and 2 illustrating the sensor mounting.

FIG. 4 is a partial sectional view of another sensor mounting in an implant.

FIG. 5 is a sectional view of the sensor and implant illustrated in FIG. 4.

FIG. 6 illustrates another orthopaedic implant assembly. FIG. 7 is a partial plan view of a removable lead.

FIG. 8 is a top view of the orthopaedic implant assembly illustrated in FIG. 6.

FIG. 9 illustrates a landmark identifier that includes a drill sleeve.

FIG. 10 is a partial and sectional view illustrating two point contacts of an implant.

FIG. 11 is another partial sectional view illustrating point contacts in another implant.

FIG. 12A is a partial and sectional view of an implant illustrating a crimp electrical connection.

FIG. 12B is a partial exploded view illustrating the electrical connection in a disclosed implant.

FIG. 12C is a side view of the electrical connection illustrated in FIG. 12B.

FIG. 12D is a partial exploded illustrating the electrical connection in another disclosed implant.

FIG. 13A is a partial perspective and exploded view illustrating alternative mechanisms for aligning a disclosed orthopaedic implant and a disclosed insertion handle.

FIG. 13B is a partial perspective and exploded view illustrating alternative mechanisms for aligning a disclosed orthopaedic implant and an electrical connection.

FIG. 14 is a partial side view illustrating a connection of the insertion handle to the orthopaedic implant.

FIG. 15 illustrates another system for identifying a landmark.

FIG. 16 is a schematic illustration of view selection criteria.

FIG. 17 is a flowchart illustrating view selection during a fixation surgery.

FIG. 18 is a schematic illustration of another method of aligning a landmark identifier.

FIG. 19 is a schematic illustration of another disclosed method of aligning a landmark identifier.

FIG. 20 illustrates a disclosed monitor with exemplary views.

FIG. 21 illustrates another disclosed landmark identifier.

FIG. 22 is a partial view another disclosed insertion handle.

FIG. 23 illustrates another disclosed system for identifying a landmark.

FIG. 24 is a partial view of yet another disclosed insertion handle.

FIG. 25 illustrates another disclosed system for identifying a landmark.

FIG. 26 is a partial cross-sectional view of an intramedullary nail.

FIG. 27 illustrates a packaging for a disclosed implant.

FIG. 28 illustrates a method of connecting a landmark identifier system to a network.

FIG. 29 illustrates yet another disclosed system for identifying a landmark.

FIG. 30 is a flow chart for using a disclosed landmark identifying system.

FIG. 31 is another flow chart for using a disclosed landmark identifying system.

FIG. 32 is a schematic illustration of tracking drill depth.

FIGS. 33A and 33B are also schematic illustrations of tracking drill depth.

FIG. 34 is a partial illustration of a disclosed device for tracking drill depth.

FIG. 35 is a perspective view of another insertion handle.

FIG. 36 is a top perspective view of an adjustable stop.

FIG. 37 is a bottom perspective view of the adjustable stop illustrated in FIG. 36.

FIG. 38 is another illustrating system calibration.

FIG. 39 is a perspective view of another landmark identifier housing a field generator and a drill sleeve and that may be sterilized or subject to an autoclave procedure.

FIG. 39a is a top perspective view of a mounting structure.

FIG. 39b is a perspective view of a drill sleeve attachment and drill sleeve.

FIG. 40 is a side view of the landmark identifier/field generator/drill sleeve of FIG. 39 making contact with a bone.

FIG. 41 is a perspective view of the landmark identifier/field generator/autoclavable housing of FIG. 39 coupled to a screw driver attachment.

FIG. 42 is a plan view of an insertion handle, adjustable stop and probe.

FIG. 43 is a perspective view of an exemplary adjustable stop to hold a probe in a desired position.

FIG. 44 is a perspective view of another exemplary adjustable stop.

FIG. 45 is a perspective view of an intramedullary nail, an insertion handle, an adjustable stop, and a probe.

FIG. 46 is a perspective view of another intramedullary nail, an insertion handle, an adjustable stop, and a probe.

FIG. 47 is a perspective view of two probes for use in targeting landmarks of an implant.

FIG. 48 is a perspective view of another probe for use in targeting landmarks of an implant.

FIG. 49 is a sectional view of a retractable probe.

FIG. 50 is a perspective view of an intramedullary, an insertion handle, and an adjustable stop.

FIG. 51 is an illustration of a system for targeting a landmark of an implant.

FIG. 52 is an illustration of a device for use in calibrating the system of FIG. 51.

FIGS. 53-62 are illustrations of adjustable stops.

It should be understood that the drawings are not necessarily to scale and that the disclosed implementations are sometimes illustrated diagrammatically and in partial views. In certain instances, details which are not necessary for an understanding of the disclosure or which render other details difficult to perceive may have been omitted. It should be understood, of course, that this disclosure is not limited to the particular implementations illustrated herein.

DETAILED DESCRIPTION

Referring to the accompanying drawings in which like reference numbers indicate like elements, FIG. 1 illustrates one disclosed system 10 for identifying a landmark. The system 10 may include a processor 12, a magnetic field generator 16, a landmark identifier 18, and an orthopaedic implant assembly 28. The system 10 may also include a monitor 14 electrically connected to the processor 12 and an insertion handle 40 removably attached to the orthopaedic implant assembly 28. The processor 12 is depicted as a desktop computer in FIG. 1 but other types of computing devices may be used. As examples, the processor 12 may be a desktop computer, a laptop computer, a personal data assistant (PDA), a mobile handheld device, or a dedicated device. The magnetic field generator 16 is a device available from Ascension Technology Corporation of 107 Catamount Drive, Milton Vt., U.S.A.; Northern Digital Inc. of 103 Randall Drive, Waterloo, Ontario, Canada; or Polhemus of 40 Hercules Drive, Colchester Vt., U.S.A. Of course, other generators may be used. As examples, the field generator 16 may provide a pulsed direct current electromagnetic field or an alternating current electromagnetic field. The system 10 may also include a control unit (not shown) connected to the magnetic field generator 16. The control unit controls the field generator 16, receives signals from small mobile inductive sensors, and communicates with the processor 12, either by wire or wirelessly. The control unit may be incorporated into the processor 12 either through hardware or software.

The system 10 is a magnetic position tracking system. For illustrative purposes, the system 10 may include a magnetic field generator 16 comprised of suitably arranged electromagnetic inductive coils that serve as the spatial magnetic reference frame (i.e., X, Y, Z). The system 10 may also include small mobile inductive sensors, which are attached to the object being tracked. It should be understood that other variants could be easily accommodated. The position and angular orientation of the small mobile inductive sensors are determined from its magnetic coupling to the source field produced by magnetic field generator 16.

It is noted that the magnetic field generator 16 generates a sequence, or set, of here six, different spatial magnetic field shapes, or distributions, each of which is sensed by the small mobile inductive sensors. Each sequence enables a sequence of signals to be produced by the small mobile inductive sensors. Processing of the sequence of signals enables determination of position and/or orientation of the small mobile inductive sensors, and hence the position of the object to which the small mobile inductive sensor is mounted relative the magnetic coordinate reference frame which is in fixed relationship to the magnetic field generator 16. The processor 12 or the control unit may use the reference coordinate system and the sensed data to create a transformation matrix comprising position and orientation information.

The landmark identifier 18 is used to target a landmark, such as a landmark on the orthopaedic implant assembly 28. The landmark identifier 18 may include one or more small mobile inductive sensors or may include the field generator. The landmark identifier 18 has a second sensor 20. The landmark identifier 18 may be any number of devices. As examples, the landmark identifier may be a device that includes a structure that provides a user with an understanding of the location and orientation of a hidden landmark. For example, the landmark identifier can include a drill guide, a drill sleeve, a drill, a drill nose, a drill barrel, a drill chuck, or a fixation element. In some implementations, the structure can be a housing having an opening, or other structure that indicates the location and orientation of a landmark. In FIG. 1, the landmark identifier 18 is a drill sleeve and includes a sensor 20, whereas in FIG. 39, the landmark identifier 2016 includes a housing 2020 having a central aperture and includes a magnetic field generator (not shown) in the housing 2020. The landmark identifier 18 may include one or more of a serrated tip 22, a tube 24, and a handle 26. The tube 24 also may be referred to as a bushing, cylinder, guide, or drilling/screw placement guide. The second sensor 20 is oriented relative to an axis of the tube 24. The tube 24 may receive a drill. This offset of the sensor 20 from the tube 24 allows the position and orientation of the tube to be located in space in six dimensions (three translational and three angular) relative to the magnetic field generator 16 and/or another sensor in the system. The processor 12 may need to be calibrated to adjust for the offset distance of the second sensor 20. The landmark identifier 18 and the field generator 16 may be combined into a single component. For example, the field generator 16 may be incorporated within the handle 26.

The orthopaedic implant assembly 28 may include an implant 30 and one or more small mobile inductive sensors. The orthopaedic implant assembly 28 includes a first sensor 32. In FIG. 1, the implant 30 is in the form of intramedullary nail but other types of implants may be used. As examples, the implant may be an intramedullary nail, a bone plate, a shoulder prosthetic, a hip prosthetic, or a knee prosthetic. The first sensor 32 is oriented and in a predetermined position relative to one or more landmarks on the implant 30. As examples, the landmark may be a structure, a void, a boss, a channel, a detent, a flange, a groove, a member, a partition, a step, an aperture, a bore, a cavity, a dimple, a duct, a gap, a notch, an orifice, a passage, a slit, a hole, or a slot. In FIG. 1, the landmarks are transfixion holes 31. The offset of the first sensor 32 from the landmark allows the position of the landmark to be located in space in six dimensions (three translational and three angular) relative to the magnetic field generator 16 or another sensor in the

system, such as the second sensor 32. The processor may need to be calibrated to adjust for the offset distance of the first sensor 32.

The first sensor 32 and the second sensor 20 are coupled to the processor 12. This may be accomplished by wire or wirelessly. The first sensor 32 and the second sensor 20 may be a six degree of freedom sensor configured to describe the location of each sensor in three translational axes, generally called X, Y and Z and three angular orientations, generally called pitch, yaw and roll. By locating the sensor in these reference frames, and knowing the location and orientation of each sensor, the landmark identifier 18 may be located relative to the landmark on the implant 30. In one particular implementation, the information from the sensors allows for a surgeon to plan the surgical path for fixation and properly align a drill with a blind fixation hole 31. The sensors 32, 20 are six degrees of freedom sensor from Ascension Technology Corporation of 107 Catamount Drive, Milton Vt., U.S.A.; Northern Digital Inc. of 103 Randall Drive, Waterloo, Ontario, Canada; or Polhemus of 40 Hercules Drive, Colchester Vt., U.S.A. Of course, other sensors may be used.

The first sensor 32 may be attached to the implant 30. For example, the first sensor 32 may be attached to an outer surface 37. In FIG. 1, the implant 30 may also include a groove 34 and a pocket 36 (best seen in FIG. 2). The groove 34 and pocket 36 are located in a wall of the implant 30. The first sensor 32 is intended to be attached to the implant 30 and installed in a patient for the service life of the implant 30. Further, the orthopaedic implant assembly 28 may include a cover 38 to cover the pocket 36 and/or the groove 34. The cover 38 may be substantially flush with the external surface 37 of the implant 30. Accordingly, the implant 30 may include a second opening 39 (see FIG. 2) to receive the cover 38.

The first sensor 32 may be tethered to leads for communication and power. The leads, and the sensor, may be fixed to the implant 30. A lead 50 may be used to connect the first sensor 32 to the processor 12 or the control unit. The lead 50 may be made from biocompatible wire. As an example, the lead 50 may be made of DFT wire available from Fort Wayne Metals Research Products Corp., 9609 Indianapolis Road, Fort Wayne, Ind. 46809. DFT is a registered trademark of Fort Wayne Metals Research Products Corp. A first connector 52 may be used to place the lead 50 relative to the implant 30. A second connector 54 may be used to connect the lead 50 to another device, such as the processor 12, the control unit, or the insertion handle 40.

The first sensor 32 may be fixed in the pocket 36 using a range of high stiffness adhesives or polymers including epoxy resins, polyurethanes, polymethyl methacrylate, polyetheretherketone, UV curable adhesives, silicone, and medical grade cyanoacrylates. As an example, EPO-TEK 301 available from Epoxy Technology, 14 Fortune Drive, Billerica, Mass. 01821 may be used. The lead 50 may be fixed in the groove in a similar manner. These types of fixation methods do not adversely affect the performance of the electrical components. Thereafter, the cover 38 may be placed on the implant 30 and welded in-place. For example, the covers may be laser welded to the implant.

The monitor 14 may be configured to display the position and orientation of the first sensor 32 and the second sensor 20 so that the display may show a surgeon both sensor positions and orientations relative to one another. The processor 12 may send positional data, either by wire or wirelessly, to a user interface, which may graphically display the relative positions of the landmark identifier and the implant on the monitor. The view displayed on the monitor

14 may be oriented relative to the landmark identifier so that the surgeon may visualize the user interface as an extension of the landmark identifier. The user interface also may be oriented so that the surgeon may view the monitor simultaneously with the surgical field.

The insertion handle 40 may be used for installation of the orthopaedic implant assembly 28 and also may be used to route the leads from the first sensor 32. For example, the insertion handle 40 may route both communication and power leads between the implant 30 and the processor 12.

In FIG. 1, the landmark identifier 18 and the insertion handle 40 each include a communications module 21, 25 for wirelessly transmitting data from the sensor 20, 32 to the processor 12, but those skilled in the art would understand that other methods, such as by wire, may be used. The second connector 54 plugs into the communications module 25. Alternatively, and as is explained in greater detail below, the implant 30 and the insertion handle 40 may have mating electrical contacts that form a connection when the components are assembled such that the first sensor 32 is connected to the communications module 25.

The implant 30 may include a communications circuit and an antenna for wireless communication. Power for the first sensor 32 and/or the communications circuit may be positioned within the insertion handle 40. For example, a battery may be placed within the insertion handle 40 for transferring power to the first sensor 32 and/or other electronics. Alternatively, the communications circuit, the antenna, and the battery may be located within the insertion handle 40 and each of these may be tethered to the first sensor 32. In yet another implementation, the implant 30 may include a coil to inductively power the communications circuit and communicate data from the first sensor 32. The power source may be a single source mode or may be a dual mode AC/DC.

In use, the orthopaedic implant assembly 28 is installed in a patient. For example, in the case of internal fixation, the intramedullary nail is placed within an intramedullary canal. Optionally, the user may use transfixion elements, such as screws, to first lock the proximal end of the intramedullary nail. An operator uses the targeting device 18 and the first sensor 32 to identify the landmarks. For example, in the case of intramedullary nail fixation, a surgeon uses the targeting device 18 to identify the blind transfixion holes 31 and drill through the holes 31 for placement of a transfixion element.

FIG. 2 further illustrates the implant 30 as illustrated in FIG. 1. The implant 30 may include the first sensor 32, the longitudinal groove 34, the pocket 36, the cover 38, and the second opening 39. As examples, the cover 38 may be comprised of gold or titanium foil. The implant 30 may include an inner surface 35 that forms a cannulation 33. The outer surface of the implant 30 is shown at 37.

FIG. 3 illustrates an implementation of the first sensor 32. The first sensor 32 may include two coils cross-layered to one another and having an angle α .

FIGS. 4 and 5 illustrate another implementation of the first sensor 32. The first sensor may include two coils generally orthogonal to one another in order to establish the orientation and position in the six degrees of freedom. A first coil may be oriented along the length of the implant 30. The second coil may be oriented either wrapped around the circumference of the implant, for example in a groove, or along the radius of the implant 30. In addition, while the coils may be perpendicular to one another, other orientations may be used, although the mathematics may be more complex. Further, the coils may be oriented spirally around the implant 30. Such an orientation may allow two coils to

be placed perpendicular to each other with both coils placed along both the length of the implant and along the circumference of the implant 30.

FIGS. 6-8 illustrate a second implementation of the orthopaedic implant assembly 60. The orthopaedic implant assembly 60 may include the implant 30. In FIG. 6, the implant 30 includes landmarks in the form of transfixion holes 31. The implant 30 may include a longitudinal internal groove 66 and a removable lead 64. In FIG. 8, a diameter of the longitudinal groove 66 is shown as intersecting with the cannulation 33; however, in other implementations, the diameter of the longitudinal internal groove is contained between the outer surface 37 and the inner surface 35. The removable lead 64 may include the first sensor 32 at its distal end portion 65. The first sensor 32 is located a known offset from the landmarks 31. The implant in FIGS. 6-8 is comprised of biocompatible material, and may be a metal alloy or a polymer. The longitudinal groove 66 may be machined or molded in place.

In use, the implant 30 with the removable lead is installed in a patient. For example, in the case of internal fixation, the intramedullary nail is placed within an intramedullary canal. Optionally, the user may use transfixion elements, such as screws, to first lock the proximal end of the intramedullary nail. Because of the location of the longitudinal groove 66, the removable lead 64 does not interfere with locking the proximal end of the intramedullary nail. An operator uses the targeting device 18 and the first sensor 32 to identify the landmarks 31. For example, in the case of intramedullary nail fixation, a surgeon uses the targeting device 18 to identify the blind transfixion holes 31 and drill through the holes 31 for placement of a transfixion element. After the implant 30 is secured, the operator removes the removable lead 64 and it may be discarded.

A method for identifying a landmark is disclosed. The method may include providing an orthopaedic implant assembly having an orthopaedic implant with a longitudinal groove and a removable lead or probe having an electromagnetic sensor attached thereto situated within the longitudinal groove. The orthopaedic implant includes a proximal end portion, a distal end portion, and at least one landmark on the distal end portion. The method includes implanting the orthopaedic implant assembly in a patient. Then, transfixion elements in the proximal end portion are installed. At least one distal landmark is identified using a landmark identifier. A transfixion element is installed in the at least one distal landmark. The removable lead or probe may then be removed. The situation of the removable lead or probe within the longitudinal groove allows for proximal locking of the implant prior to distal locking.

FIG. 9 illustrates the landmark identifier 18 of FIG. 1. The landmark identifier 18 may include the sensor 20, the serrated tip 22, the tube 24, and the handle 26. A drill 90 has markings 92 that interact with a marking sensor 19 adjacent the tube 24. The interaction is similar to a pair of digital measuring calipers in that the position between the markings 92 and the sensor 19 equate to a distance. This distance can be used to determine the depth of the drill into the bone and ultimately the length of the bone screw that will be inserted into the drilled hole. Distance, or drill depth, readings are only obtainable when the markings 92 and the sensor 19 are in close proximity to each other, i.e. the drill 90 is inside the tube 24. Exemplary measurement devices are illustrated in U.S. Pat. Nos. 6,675,491 and 7,253,611. The marking sensor 19 is connected to the communications module 21. Alternatively, the marking sensor 19 may be connected by wire

to the processor 12. In FIG. 9, the communications module 21 may include a third connector 23 for electrical connection to the processor 12.

FIGS. 10-12 illustrate exemplary methods of electrically connecting the implant 30 to the insertion handle 40, which has corresponding electrical contacts. In FIG. 10, biasing elements 72 bias contacts 70 toward the insertion handle 40. In FIG. 11, the implant 30 has elastomeric electrical contacts 74. In FIG. 12A, wires extending between the lead 50 and another component are crimped together at junction 76. In one method, the wires are torn free and separated at the junction 76 after installation of the orthopaedic implant assembly 28. In yet another method, the wires are cut above the junction 76 after installation of the orthopaedic implant assembly 28. In FIGS. 12 B and C, two flex boards 53 are soldered together one or more pads 57 to connect a wiring harness 55 to the sensor. The wire harness 55 may be mounted to the insertion handle 40 or within a cannulation of the insertion handle 40. In the depicted implementation, four pads 57 are soldered together. Locking tabs 59 are sandwiched between the implant 30 and the insertion handle 40 to withstand abrasion and tension associated with the implant insertion. Once the insertion handle 40 is removed, the wire harness 55 can be pulled such that all non-biocompatible materials are pulled with it. In FIG. 12D, rings 61, 63 are connected during manufacturing. After implantation, both rings 61, 63 are removed by pulling on a jacketed wire 67.

Referring now to FIGS. 13A and 13B, the implant 30 and/or the insertion handle 40 may include one or more alignment features 44 and mating notch 80 or alignment pin 46 and mating hole 82. The insertion handle may be configured to align with an upper surface of the implant. In one implementation, the insertion handle may have a key configured to mate to a slot on the implant. Other alignment guides may be used. In addition, the guide may have an electrical connector configured to mate to an electrical connector on the implant. The connection between the guide and the implant may be spring loaded to ensure electrical contact between the electrical connectors. In order to avoid shorting the connection between the guide and the implant, the electrical connector may be insulated. As another example of electrically connecting the insertion handle to the implant, the electrical connectors may include a post and slip rings. The rings may be located on the implant, and the posts located on the insertion handle. The posts are biased to contact the rings. In such an implementation, the angular location of the insertion handle 40 relative to the axis of the implant is not fixed. This would allow the insertion handle 40 to be positioned to the implant irrespective of angular position.

In another implementation shown in FIG. 13B, the implant 30 and/or the insertion handle 40 may include one or more alignment pin 47 and mating hole 83. The alignment pins 47 may be spear tip pins designed to engage a single time and when removed, the pins grip portion of the implant to remove all non-biocompatible materials with them.

Any of the electrical connectors above may include a memory storage device (not shown) for storing offset values for sensor calibration.

Referring now to FIG. 14, the implant 30 and the insertion handle 40 may be sized such that space remains available for the first connector 52 even when the components are assembled or mated. As an example, the system for identifying a landmark may be used to target blind screw holes of an implanted intramedullary nail. The intramedullary nail is implanted in the patient. The electromagnetic field generator

is activated. The processor receives signals from the sensor mounted to the intramedullary nail and from the sensor mounted to the landmark identifier, such as a drill sleeve. A computer program running on the processor uses the information of the at least two sensors and graphically display 5 them in relative position on the monitor. A surgeon moves the landmark identifiers into position using feedback provided by the processor. When the landmark identifier is in the proper location, the surgeon drill through bone and the intramedullary nail to create a screw hole. The processor 10 may provide feedback as to the depth of the drilled hole. The surgeon may then place a screw through the drilled hole to affix the blind hole of the intramedullary nail.

Provided feedback information may be selected from the group consisting of audible, visual, and tactile. The audible 15 feedback may be output through a speaker, headphones, ear buds, or an ear piece. The audible feedback signal may be transmitted over wire or wirelessly using radio frequency or terrestrial data transmission. The visual feedback may be output through a cathode ray tube, a liquid crystal display, or a plasma display. Visual feedback devices may include, as 20 examples, a television monitor, a personal digital assistant, or a personal media player. The visual feedback signal may be transmitted over wire or wirelessly using radio frequency or terrestrial data transmission. The tactile feedback may be output through gloves, instruments, or a floor mat. The tactile feedback signal may be transmitted over wire or wirelessly using radio frequency or terrestrial data transmission.

FIG. 15 illustrates a system 110 for identifying a landmark 30 in another implementation. The system 110 may include a processor 112, a landmark identifier 118, and an orthopaedic implant assembly 128. The system 110 may also include a monitor 114 and an insertion handle 140.

The landmark identifier 118 is used to target a landmark. 35 The landmark identifier 118 may include a second sensor 120. In FIG. 15, the landmark identifier 118 is a drill sleeve with a serrated tip 122, a tube 124, and a handle 126. The second sensor 120 is oriented relative to an axis of the tube, which may receive a drill. This offset of the sensor from the tube allows the position of the tube to be located in space in six dimensions (three translational and three angular) relative to the transmitter or another sensor in the system. The processor may need to be calibrated to adjust for the offset distance of the second sensor 120. 40

The orthopaedic implant assembly 128 may include an implant 130 and a magnet 132.

The magnet may be a permanent magnet or an electromagnet. The magnet 132 is oriented in a predetermined position relative to a landmark on the orthopaedic implant 130. This offset of the magnet from the landmark allows the position of the landmark to be located in space in six dimensions (three translational and three angular) relative to the transmitter or another sensor in the system, such as the second sensor. The processor may need to be calibrated to adjust for the offset distance of the magnet 132. As with the implant 30 of FIG. 1, the implant 130 may also include a pocket 136 and a cover 138. In the case of an electromagnet, a lead 150 connects to the magnet 132 and is contained within a groove 134. 45

As an example, the system for identifying a landmark may be used to target blind screw holes of an implanted intramedullary nail. The intramedullary nail is implanted in the patient. The processor receives signals from the sensor mounted to the landmark identifier, such as a drill sleeve. A computer program running on the processor uses the information of the sensor and graphically displays the sensor in 50

relative position to the magnet on the monitor. A surgeon moves the landmark identifiers into position using feedback provided by the processor. When the landmark identifier is in the proper location, the surgeon drill through bone and the intramedullary nail to create a screw hole. The processor may provide feedback as to the depth of the drilled hole. The surgeon may then place a screw through the drilled hole to affix the blind hole of the intramedullary nail.

FIG. 16 illustrates a method for selecting views corresponding to landmark identifier position. The view displayed on the monitor is dependent upon the location of the landmark identifier relative to the implant. The diameter of the implant is broken into sectors or fields. In FIG. 16, the diameter is broken down into three fields: (A) 135° to 225°; (B) 0° to 135°; and (C) 225° to 360°. The initial view is based upon landmark identifier orientation relative to the implant. As the user moves landmark identifier toward or away from the implant, the monitor display zooms in or out on the selected field.

FIG. 17 is a flowchart for view selection and display of one landmark. The process may be repeated for multiple landmarks. The processor 12 uses the transformation matrix in the following process steps. In step 200, landmark identifier position is computed relative to the implant based upon the positions of the relevant sensors, and the landmark closest to the landmark identifier is selected for display. In step 210, a global view is defined showing the whole implant with the selected landmark oriented for proper viewing. A global view is analogous to viewing the implant at a distance. In step 220, there is a decision whether there are multiple landmarks having the same orientation. If yes, then in step 230, the processor calculates which landmark is nearest to the landmark identifier position and selects it for viewing. If no, in step 240, a local view is defined and centered upon the selected landmarks. A local view is analogous to viewing the implant in close proximity. In some implementations, it may be desirable to hide the landmark identifier when the local view is defined. In steps 250, 260, and 270, the processor 12 identifies the distance from landmark identifier to the landmark and depending upon the decision made, either hides or renders the landmark identifier. In step 250, the distance from landmark identifier to the landmark and a comparison is made between the calculated distance D and set variables T_{Global} and T_{Local} . If $D > T_{Global}$, then the global view is selected in step 260 and the processor proceeds to step 285. If $D < T_{Local}$, then the local view is selected and centered upon the landmark in step 270. Thereafter, the processor proceeds to step 275. In optional step 275, the landmark identifier is hidden. Otherwise, an intermediate camera position is calculated based upon the distance D to enable a smooth transition from global view to a local view in step 280. In step 285, the landmark identifier is shown. In step 290, the scene with selected camera position is rendered.

FIG. 18 is a schematic illustrating a first alternative method of aligning the landmark identifier. A computer program running on the processor may be used to take the information of the at least two sensors and graphically display them in relative position (the second sensor relative to the first sensor) on the monitor. This allows the user to utilize the system to guide the placement of the landmark identifier. In the case of drilling a blind intramedullary nail hole, the system guides the user in placement of the drill sleeve and subsequently drilling accurately thru the hole in the intramedullary nail. The graphical user interface may include an alignment guide for each of the degrees of freedom. A minimum alignment level may be set such that 60

the surgeon continues to orient the landmark identifier until each of the degrees of freedom meets the minimum alignment level for an effective placement of the landmark identifier. The example of FIG. 18 shows an instance where the placement in the Y-direction meets the minimum required tracking placement. However, none of the other translational or rotational meets the minimum requirements. While the magnitudes of tracking are illustrated as bar graphs, other graphical representations, such as color coding, may be used.

FIG. 19 is a schematic illustrating a second alternative method of aligning the landmark identifier. In this implementation, a graphical interface using a plurality of LEDs to position the drill may be placed upon the landmark identifier, such as a drill sleeve. By using the LEDs to trajectory track the drill, the surgeon may align the drill with the blind fixation hole. The trajectory may additionally use secondary displays to add more information to the system. For example, for affecting the magnitude of adjustment, the trajectory may include flashing LEDs so that high frequency flashing requires larger adjustments while low frequency flashing may require smaller adjustments. Similarly, colors may add information regarding adjustments to alignment.

FIG. 20 illustrates a monitor with exemplary views. A first portion 500 indicates the distance the drill is on each side of the implant. This may provide the user with a better understanding of drill depth and alert the user when to stop when appropriate drill depth has been achieved. The second portion 510 provides the user with alignment information. As an example, drill depth data may be obtained using the implementation illustrated in FIG. 9.

FIG. 21 illustrates an alternative implementation of the landmark identifier. The landmark identifier is configured to display, with LEDs, the position and trajectory information for proper alignment. The size of the LEDs may display additional information regarding the magnitude of required adjustment. The trajectory light may display a simple on/off toggle between an aligned trajectory and a mal-aligned trajectory. As another example, the trajectory LED may be color coded to suggest the magnitude of necessary adjustment for proper alignment.

FIG. 22 illustrates a first alternative implementation of the insertion handle 700. The insertion handle 700 may include an arcuate slot 710. The arcuate slot limits the movement of the landmark identifier 18, 118 within the operating space. In the case of identifying a blind screw hole, the arcuate slot limits the movement of the drill sleeve for fine adjustment of its position. The insertion handle 700 may include a carriage 712 that receives the landmark identifier and rides in the slot 710.

FIG. 23 illustrates the system for identifying a landmark in a third implementation. In this implementation, the orthopaedic implant 800 is a bone plate and the insertion handle 810 is a little guide affixed to the bone plate. The inductive sensor is placed on the surface of the orthopaedic implant 800 relative to one or more landmarks. The guide 810 may allow a landmark identifier 818 to translate and/or rotate relative to the guide to properly align the landmark identifier with a landmark 802, such as a fastener hole. In addition, where multiple fixation holes are on the implant, then additional guide holes 812 on the guide 810 may help approximate the position of the additional fixation holes.

FIG. 24 illustrates a second alternative implementation of the insertion handle. The insertion handle 900 may include fine adjustment in landmark identifier 918 positions through the use of small servomotors 920, 922, 924. The servomotors 920, 922, 924 may adjust the orientation and position of

the landmark identifier 918. Control of the servos may be automatic or may be controlled by a surgeon.

FIG. 25 illustrates a bone 100 and another system 1010 for identifying a landmark. The system 1010 may include a control unit 1012, a field generator 1014, a landmark identifier 1016, an intramedullary nail 1024, and a probe 1029. The landmark identifier 1016 also may be referred to as a targeter. The control unit 1012 may be included as part of the processor described above or may be a separate unit. The intramedullary nail 1024 is inserted into the bone 100, and the intramedullary nail 1024 has a hole or landmark 1028. The field generator 1014 is electrically connected to the control unit 1012. An insertion handle 1022 is removably attached to the intramedullary nail 1024. The insertion handle 1022 and/or the intramedullary nail 1024 may be formed with a cannulation. The insertion handle 1022 may include a third sensor 1032.

The landmark identifier 1016 may include a second sensor 1020. The landmark identifier 1016 may guide a drill bit 1018, and the drill bit 1018 may be connected to a drill (not shown). The second sensor 1020 may be connected to the control unit 1012, either by wire or wirelessly. The field generator 1014 may be included in or on the landmark identifier 1016, in which case, the second sensor 1020 may be omitted.

The probe 1029 may include a wire 1030, a tape 1034, and a stop 1036. The tape 1034 may be about 0.125 inch wide by about 0.060 inch thick 300 series stainless steel fish tape available from Ideal Industries, Inc. of Sycamore, Ill. However, those of ordinary skill in the art would understand that other materials and other sizes may be used. For example, any narrow band of polymer, composite material, or metal may be used as the tape 1034, but it may be preferred to use a non-ferrous metal. The tape 1034 may be coiled before placement into the intramedullary nail 1024. Coiling of the tape 1034 may cause it to have a natural curvature. The tape 1034 may have, in some implementations, a rectangular geometry that assists in orienting the tape as it is placed into a cannulation of the intramedullary nail 1024. An oval, square, or circular geometry also may be used. The wire 1030 may be operatively connected to the tape 1034. For example, this may be accomplished through the use of an adhesive or fastener. The tape 1034 may include graduations or detents to indicate a depth of the tape as it is inserted into the implant.

A first sensor 1026 is connected to the control unit 1012, either by wire or wirelessly. The first sensor 1026 is connected through the use of the wire 1030 and a connector 1038. The connector 1038 may be omitted. The first sensor 1026 may be connected to a distal end of the tape 1034, and the stop 1036 may be connected to a proximal end of the tape 1034.

The probe 1029 may include a sensor housing (not shown) to house the first sensor 1026. The sensor housing may be attached to the tape 1034. The sensor housing may be made of a non-ferrous material, such as a polymer, a composite, or a metal. The sensor housing may include an appropriate strain relief to shield the wire 1030 from stresses. The sensor housing may be constructed and arranged to be large enough to hold the first sensor 1026 but small enough to fit through the cannulation of the insertion handle or the implant. Further, the sensor housing may be constructed and arranged to be long enough to allow passage through intramedullary nail bends, intramedullary nail bow, and/or bends in relevant instrumentation. Geometry of the leading and trailing faces of the sensor housing may be

designed such that the sensor housing does not catch or snag on the cannulation of the instrumentation or implant.

The stop **1036** may be used to control the placement of the sensor **1026** and probe **1029**. If the tape **1034** is a fixed length and the distance is known from the end of the insertion handle to the hole **1028**, repeatable placement of the first sensor **1026** may be achieved. The tape **1034** may be of sufficient length such that the sensor **1026** is aligned with the hole **1028**, adjacent the hole **1028**, or offset from the hole **1028**. As discussed below, the probe **1029** may be used to position the sensor with the hole **1028** or other landmark.

The insertion handle **1022** may be omitted. In such a case, a different tape length may be selected such that the stop **1036** engages a portion or end of the nail **1024**.

FIG. **26** is a partial detailed view of the intramedullary nail **1024**, the sensor **1026**, and the hole **1028**. The sensor **1026** may be aligned with the hole **1028**, adjacent the hole **1028**, or offset from the hole **1028**. The sensor **1026** is generally adjacent to the hole **1028**.

In use, the intramedullary nail **1024** is placed into the bone **100**. The insertion handle **1022** may be attached to the intramedullary nail **1024**. The probe **1029** is fed through the cannulation of the insertion handle **1022** and into the cannulation of the intramedullary nail **1024** until the stop **1036** engages the insertion handle **1022**. In one particular implementation, the wire **1030** is connected to the control unit **1012**, and the sensors **1026**, **1020**, and **1032** are calibrated using the control unit **1012**. The probe **1029** may be removed after calibration. If so, the third sensor **1032** and a transformation matrix may be used to identify the relative position of the second sensor **1020** and hence landmark identifier **1016**. Optionally, the user may use transfixion elements, such as screws, to first lock the proximal end of the intramedullary nail. An operator uses the landmark identifier **1016** and the first sensor **1026** to identify the landmarks **1028**. For example, in the case of intramedullary nail fixation, a surgeon uses the landmark identifier **1016** to identify the blind transfixion holes and drill through the holes for placement of a transfixion element.

FIG. **27** illustrates a packaging implementation. In general, intramedullary nails must be sterilized before implantation. If the sensor is installed in the intramedullary nail prior to serialization, the sensor may lose its calibration during the serialization process, particularly if the sterilization process involves radiation. For example, gamma radiation may be used to sterilize hermetically sealed components, such as the sensor. The implementation depicted in FIG. **27** illustrates a way to maintain the sterilization of the intramedullary nail while allowing for recalibration of the sensor. The package FIG. **27** may include a first package **1040**, a second package **1042**, a first connector **1044**, a second connector **1046**, and a cable **1048**. In the depicted implementation, a sensor (not shown) and intramedullary nail **1024** are located within the first package **1040**. Alternatively, the probe **1029** and the sensor are located within the first package **1040**. In yet another example, only the sensor is located within the first package **1040**. A memory device (not shown) may be connected to the sensor. The memory device may be used to store a calibration transformation matrix ($x1, y1, z1, x2, y2, z2$) as well as other data, such as length and size of the intramedullary nail or the probe. The memory device may be mounted to or placed on the intramedullary nail **1024** or the probe **1029**. The first connector **1044** is electrically connected, but removably attached, to the second connector **1046**. The first connector **1044** is also electrically connected to the sensor or the memory device. The first package **1040** maintains the ster-

ilization of the device held within. The cable **1048** is electrically connected to the second connector **1046** and a storage device (not shown). The calibration for the sensor is downloaded from the storage device and transmitted through the connectors **1044**, **1046** to the sensor or the memory device. The calibration step may be performed during manufacturing of the system or immediately prior to implantation of the implant.

FIG. **28** illustrates a method of connecting the system **1010** to a network. FIG. **28** illustrates a network **1060**, a computing device **1050**, the cable **1048**, the second connector **1046**, the first connector **1044**, and the intramedullary nail **1024**. In the depicted implementation, a sensor (not shown) is located within the intramedullary nail **1024**. Alternatively, the sensor may be attached to the probe **1029** or freestanding. The intramedullary nail **1024** may be wrapped in packaging, such as the first package **1040** and/or second package **1042** but this is not always the case. A memory device (not shown) may be connected to the sensor. The memory device may be used to store a calibration transformation matrix ($x1, y1, z1, x2, y2, z2$) as well as other data, such as length and size of the intramedullary nail or the probe. The memory device may be mounted to or placed on the intramedullary nail **1024** or the probe **1029**. The network **1060** maybe a local area network or a wide area network. The computing device **1054** is connected to the network **1060**. The network communication may be encrypted. The cable **1048** connects the computing device **1054** to the sensor or the memory device through the use the connectors **1044**, **1046**. In this way, the sensor calibration may be downloaded from the computing device **1054** and/or the network **1060**. While the depicted implementation illustrates the sensor within the intramedullary nail, this is not always the case. The sensor may be attached to the probe or freestanding. The memory device may be located within the control unit, and the control unit is connected to the network to download the calibration data.

FIG. **29** illustrates a system **1110** for identifying a landmark in a fourth implementation. The system **1110** may include a control unit **1112**, a field generator **1114**, a landmark identifier **1116**, an intramedullary nail **1124**, a drop **1136**, and a probe **1129**. The control unit **1112** may be included as part of the processor described above or may be a separate unit. The intramedullary nail **1124** is inserted into the bone **100**, and the intramedullary nail **1124** has a hole or landmark **1128**. The field generator **1114** is connected to the control unit **1112**, either by wire or wirelessly. In the depicted implementation, an insertion handle **1122** is removably attached to the intramedullary nail **1124**. The insertion handle **1122** and/or the intramedullary nail **1124** may be formed with a cannulation. The insertion handle **1122** may include a third sensor **1144**. The drop **1136** may include a fourth sensor **1139**.

The landmark identifier **1116** may include a second sensor **1120**. The landmark identifier **1116** may guide a drill bit **1018**, and the drill bit **1018** may be connected to a drill (not shown). The second sensor **1120** may be connected to the control unit **1112**, either by wire or wirelessly. The field generator **1114** may be included in or on the landmark identifier **1116**, in which case, the second sensor **1120** may be omitted.

The probe **1129** may include a wire **1130**, a tape **1134**, and a stop **1136**. As shown below, the probe may be more unitary in structure as well. The tape **1134** may have, in some implementations, a rectangular geometry that assists in orienting the tape as it is placed into a cannulation of the intramedullary nail **1124**. The wire **1130** may be operatively

connected to the tape 1134. For example, this may be accomplished through the use of an adhesive or fastener. A first sensor 1126 is connected to the control unit 1112, either by wire or wirelessly. The first sensor 1126 is connected through the use of the wire 1130. In some implementations, a detachable connector may be used. The first sensor 1126 may be connected to a distal end of the tape 1134, and the stop 1136 may be connected to a proximal end of the tape 1134. The stop 1136 may be used to control the placement of the sensor 1126. If the tape 1134 is a fixed length and the distance is known from the end of the insertion handle to the landmark 1128, repeatable placement of the first sensor 1126 may be achieved. The tape 1134 may be of sufficient length such that the sensor 1126 is aligned with the landmark 1128, adjacent the landmark 1128, or offset from the landmark 1128.

In use, the intramedullary nail 1124 is placed into the bone 100. The insertion handle 1122 may be attached to the intramedullary nail 1124. The probe 1129 is fed through the insertion handle 1122 and into the intramedullary nail 1124 until the stop 1136 engages the insertion handle 1122. In one particular implementation, the wire 1130 is connected to the control unit 1112, and the sensors 1126, 1120, and 1132 are calibrated using the control unit 1112. The probe 1129 may be removed after calibration. If so, the third sensor 1132 and/or the fourth sensor 1139 and a transformation matrix may be used to identify the relative position of the second sensor 1120 and hence targeter 1116. Optionally, the user may use transfixion elements, such as screws, to first lock the proximal end of the intramedullary nail. An operator uses the landmark identifier 1116 and the first sensor 1126 to identify the landmarks 1128. For example, in the case of intramedullary nail fixation, a surgeon uses the landmark identifier 1116 to identify the blind transfixion holes and drill through the holes for placement of a transfixion element.

FIG. 30 illustrates a first method for using the system to identify a landmark. The method begins at step 1210. In step 1212, the sensor is placed in the nail. In step 1214, the insertion handle is connected to the nail, and the drop is attached to the insertion handle. In step 1216, the control unit is connected to the sensor. In step 1218, the sensor is calibrated. In step 1220, the sensor is aligned with the hole. In step 1222 the sensor position is recorded through the use of the control unit. In step 1224, the sensor is removed from the nail. In step 1226, the nail is implanted into the bone. In step 1228, the hole is drilled using the targeter. The method stops in step 1230.

FIG. 31 illustrates a second method for using the system to identify a landmark. In step 1310, the tracking system is turned on. In step 1312, the intramedullary nail is inserted into bone. In step 1314, the probe 1129 is inserted into the intramedullary nail canal at a predetermined location and orientation using the stop 1136 and detents spaced along a length of the probe 1129. In step 1316, there is a decision whether the intramedullary nail needs to be locked proximally before distally. If yes, then in step 1326 the drop is attached to the nail. In step 1328, an offset is calculated between the probe and the drop. In other words, a transformation matrix is created. Alternatively, the drop is not connected to the intramedullary but instead a sensor mounted in the insertion handle is used to calculate an offset. In step 1330, the probe is removed from the nail. In step 1334, the nail is locked proximally. This may be accomplished through the use of the landmark identifier, a mechanical jig, or by manual operation. In step 1336, the landmark identifier is used to target the drill. In step 1338, the hole is drilled for the distal screw. In step 1340, the

intramedullary nail is locked distally. On the other hand, if the decision is to lock distally first, then in step 1318 the landmark identifier and probe are used to target the drill bit. In step 1320, the hole is drilled for the distal screw. In step 1322, the intramedullary nail is locked distally. In step 1324, the probe is removed from the intramedullary nail. In step 1324, the intramedullary nail is locked proximally. This may be accomplished through the use of the landmark identifier, a mechanical jig, or by manual operation.

FIG. 32 illustrates a system for measuring depth of drill bit placement. The system 1400 may include a stator 1410 and a slider 1412. The stator 1410 and the slider 1412 form a capacitive array that can sense relative motion. Moving the stator 1410 and the slider 1412 in a linear relation relative to one another causes a voltage fluctuation that can be interpreted and used to determine the distance traveled. In some implementations, an electronic measuring circuit (not shown) and the slider 1412 may be housed inside the landmark identifier, and the drill bit may be specially constructed to have the stator 1410 along outer surface so that the stator 1410 and the slider 1412 are in very close linear proximity to each other. The linear movement of the drill bit stator 1410 induces a voltage in the receiving slider 1412 which is interpreted by the electronic measuring circuit as a distance measurement. The distance measurement may be sent to the control unit and/or displayed on the monitor. Capacitive sensors are highly susceptible to moisture, and so some implementations may be made to prevent liquids, such as bodily fluids, from traveling between the stator 1410 and the slider 1412. O-rings or some other similar form of wipes can be incorporated within the landmark identifier in order to keep the drill bit substantially moisture free.

Alternatively, the drill bit can be provided with reference markings, such as distance measurements, and a jig can be used to determine the depth of insertion into bone of the drill bit. For example, a separate sleeve (not shown) or a drill sleeve of a landmark identifier, such as the tube 24 discussed above, can be placed over the drill bit before drilling such that a first end of the sleeve, such as the tip 22, is placed against the bone surface to be drilled. When the drill bit is passed through the sleeve and into the bone, a second end of the sleeve serves as a reference portion to indicate the depth of insertion of the drill bit. For example, a marking on the drill bit that is aligned with the reference portion denotes a depth of insertion of the drill. Similarly, depth of insertion of a fastener, such as a locking screw, can be gauged in a similar manner. For example, a driver sleeve can be provided over a fastener and a fastener driver. The fastener driver can include a laser etched image of all or a portion of the fastener, such as the fastener head, on an exterior surface and/or can include one or more other reference marks, such as circumferential grooves or other markings. In use, as the fastener is inserted into a bone, the image of the fastener and/or the other reference marks move relative to a reference portion of the sleeve, such as the end of the sleeve. Based on the relative positions of the reference portion of the sleeve and the image or other markings, the depth of the insertion of the fastener can be determined. For example, when the end of the sleeve is aligned with a circumferential groove of the driver that is positioned immediately below an image of the head of the fastener, the sleeve indicates that the base of the head of the fastener is flush with the bone. So long as the sleeve is not covering any part of the image of the head, this indicates that the actual head of the fastener is entirely above the surface of the bone.

FIGS. 33A and 33B illustrate another system for measuring depth of drill bit placement. The system 1500 may

include a reflective code wheel or strip **1510**, a lens **1512**, and an encoder **1514**. The lens **1512** focuses light onto bar of the code strip **1510**. As the code strip **1510** rotates, an alternating pattern of light and shadow cast by the window and bar, respectively, falls upon photodiodes of the encoder **1514**. The encoder **1514** converts this pattern into digital outputs representing the code strip linear motion. The encoder is an Avago Technologies AEDR-8300 Reflective Optical Encoder available from Avago Technologies of 350 W Trimble Road, San Jose, Calif. Alternatively, the Avago Technologies ADNS-5000 One Chip USB LED-based Navigation System may be used. The encoder and its supporting electronics may be mounted inside the landmark identifier so that its input region is oriented toward a “window” in the landmark identifier cannulation. Markings, such as dark colored concentric rings or bright reflective rings, may be added to the drill bit in order to enhance the visibility of the bit to the encoder. These markings could also be used to denote the starting zero point for measurement. As the drill bit moves linearly within the landmark identifier, the encoder measures the movement of the drill bit. The distance measurement may be sent to the control unit and/or displayed on the monitor.

FIG. **34** illustrates yet another system for drill depth measurement. The system **1600** utilizes a Linear Variable Differential Transformer (LVDT) **1612**. An LVDT is a type of electrical transformer used to measure linear displacement. The LVDT **1612** may include a plurality of solenoid coils **1618** placed end-to-end around a tube **1610**, which is the landmark identifier in the depicted implementation. In FIG. **34**, the center coil is the primary coil and the outer two coils are the secondary coils. A cylindrical ferromagnetic core **1610**, such as the drill bit, slides along the axis of the tube. An alternating current **1614** is driven through the primary coil, causing a voltage to be induced in each secondary proportional to its mutual inductance with the primary. A pickup sensor **1616** measures the magnitude of the output voltage, which is proportional to the distance moved by the core (up to its limit of travel). The phase of the voltage indicates the direction of the displacement. Because the sliding core does not touch the inside of the tube, it can move without friction, making the LVDT a highly reliable device. The absence of any sliding or rotating contacts allows the LVDT to be completely sealed against the environment. The distance measurement may be sent to the control unit and/or displayed on the monitor.

FIGS. **35-37** illustrate an insertion handle **1700** (FIG. **35**) and an adjustable stop **1800** (FIGS. **37-38**). The insertion handle **1700** a stem **1710** that connects to an implant, such as an intramedullary nail (not shown), at an end portion **1712**. The insertion handle **1700** may include a quick connect **1716** for attachment to a drop, proximal targeting device, or some other instrument or apparatus. The insertion handle may include a top portion **1714**, which may include a hole and/or an alignment feature. The adjustable stop **1800** may include a slot **1810**, an alignment member **1812**, and a fastener hole **1814**.

In FIGS. **35-37**, the adjustable stop **1800** may be removably attached to the top portion **1714** of the handle **1700**. The adjustable stop may be integrally formed with the insertion handle **1700**. In yet other implementations, the adjustable stop may be permanently attached to the insertion handle **1700**. The alignment member **1812** fits within an alignment feature of the top portion to prevent rotation of the adjustable stop. A fastener (not shown) may be placed through the fastener hole **1814** to attach the adjustable stop to the insertion handle **1700**. The tape **1034**, **1134** may be placed

through the slot **1810**, through the stem **1710**, and into the intramedullary nail cannulation. The slot **1810** may have a shape to match the geometry of the tape and/or probe **1129** to aid in its insertion or to prevent rotation of the tape. The tape **1034**, **1134** or probe **1129** may include markings, graduations, or detents to indicate an appropriate depth for the given nail length. The adjustable stop **1800** may include a locking mechanism (not shown) to temporarily lock the tape **1034**, **1134** at a particular depth. In its simplest form, the locking mechanism may be a fastener that frictionally engages the tape **1034**, **1134**.

FIG. **38** illustrates a method for calibrating the system for identifying a landmark. Calibration is necessary for accuracy. The method begins at step **1900**, which may include powering up the system. In step **1910**, the probe and the landmark identifier are removed from packaging, if any, and scanned. The drop is also scanned. Scanning may include reading a bar code using a bar code reader. Scanning causes the system to retrieve offset sensor values that correspond to the bar code from a look up table in step **1912**. The look up table may be local or accessed over a network, such as the Internet. Alternatively, the probe and the landmark identifier may include a serial number or other unique identifier, and the unique identifier is used in conjunction with the look up table to retrieve offset sensor values. The offset sensor values are stored in local memory of the system in step **1914**. In step **1916**, the user places the probe relative to the implant and attempts to track a landmark using the landmark identifier in step **1916**. In step **1918**, there is a decision whether the calibration is correct. If so, the method ends in step **1920**. Otherwise, new offset values are retrieved in step **1912**.

FIG. **39** illustrates an implementation combining a landmark identifier, a field generator and a drill sleeve. The handheld landmark identifier **2016** houses an electromagnetic field generator (not shown) which may include one or more induction coils or other elements to create a suitable electromagnetic field or fields. The electromagnetic field generator is mounted in or on an autoclavable material and encapsulated in an autoclavable housing body **2018** that may be easily sterilized, and which is removably engageable with a tool. The relative orientation and position of the induction coils or elements in the landmark identifier **2016** may be selected to optimize the balance between the qualities and strength of the electromagnetic field or fields and their interaction with the sensor and the weight, size, form factor and ergonomics of the identifier **2016**. At least three induction coils (not shown) may be mounted in or on the autoclavable material.

For example, as shown in FIG. **39a**, the landmark identifier **2016** includes a mounting structure **2030**. The mounting structure **2030** includes elements **2031**, such as receptacles or posts, that are configured to receive induction coils of the electromagnetic field generator at locations and orientations. For example, each the elements **2031** is formed in or on the mounting structure **2030** such that each element **2031** has a size and a shape that conforms to a portion of an induction coil such that the element allows an induction coil to be disposed within or on the element **2031** at predetermined locations and at predetermined orientations. The induction coils can then be secured within or on the elements using adhesive, mechanical fasteners, or other securing devices or techniques. Lead wires for the coils can be routed within channels **2033** formed in the mounting structure **2030**. Alternatively, the elements can be formed having other shapes, such as a post, and the position and orientation of each induction coil can be controlled during assembly by a jig or other assembly technique. Placing the induction coils

in the predetermined locations and orientations allows use of predetermined calibration parameters for the field generator and/or for sensors. As a further alternative, the elements **2031** can be formed on the mounting structure **2030** in random locations and orientations, but following a subsequent sterilization process, the locations and orientations of the elements **2031** will remain substantially the same as further discussed below. If random locations and orientations are used, the field generator and/or the sensors may be calibrated to account for characteristics of an electromagnetic field generated by the coils.

The autoclavable materials of the landmark identifier **2016** allow the landmark identifier **2016** to be sterilized or autoclaved multiple times without degradation of the autoclavable materials, internal components, or operational performance of the landmark identifier. For example, the mounting structure **2030** on which the coils and/or other electromagnetic field generating components are mounted is formed of a material that does not adversely interfere with a generated electromagnetic field and which can be subjected to sterilization processes, including autoclaving. For example, the internal body can be formed from a glass-reinforced epoxy laminate, such as a NEMA grade G-11 glass reinforced epoxy laminate (VETRONITE G11) or equivalent. Alternatively, the mounting structure **2030** can be formed from another material that is dimensionally-stable at temperatures, pressures, humidity levels, and other environmental conditions associated with autoclaving and/or other sterilization processes. Particularly, the mounting structure **2030** is formed from a material that does not substantially expand, contract, warp, soften, or undergo any other substantial structural change during an autoclave process, referred to as a dimension stable autoclavable material. Thus, the positions and orientations of the coils and/or other components mounted on the mounting structure **2030** are not substantially altered during the autoclave process. For example, the orientation of one or more of the coils does not change by more than 2 degrees in any direction, and the locations of the coils does not change by more than 0.005 inches in any direction during an autoclave process. In addition to the glass-reinforced epoxy laminate mentioned above, suitable materials including those of carbon-fiber reinforced materials for the mounting structure **2030** include ORTHTEK RP, ORTHTEK WF, TECACOMP CF60, TECAPEEK CF30-XP98, ULTEM 1000, ULTEM 2300, Zacton 350, Garolite G-7, Garolite G-11, Garolite G-10/FR4, Garolite G9. In certain implementations, the material for the mounting structure **2030** has a flexural strength of at least about 10,000 psi. Additional materials include non-magnetic metals such as cobalt chrome, titanium, or 300 series stainless steel.

Optionally, the mounting structure **2030** can include hollow portions or lightweight inserts in areas **2037** that do not interfere with the desired locations of the elements **2031** in order to reduce the weight of the landmark identifier **2016** to about five pounds, or less, for example, and/or to achieve a desired balance of weight distribution around the landmark identifier **2016**. For example, the landmark identifier **2016** can have a center of gravity located generally within the opening, such as opening **2035** (FIG. 39a), to achieve rotational or radial balance and/or prevent rotational bias of the landmark identifier **2016** about the opening, such as rotation induced by gravity if the center of gravity is located outside the opening of the landmark identifier. For example, openings can be formed in one or more of the areas **2037**, or in other areas that do not adversely affect the placement of the components of the field generator and/or the structural

characteristics of the mounting structure, and hollow inserts can be installed in the openings. Similarly, lightweight foam material can be included in the areas **2037**. The size and location of the openings, and the difference in density of the material inserted in the openings compared to the density of the material of the mounting structure **2030** can be selected to control the location of the center of gravity of the landmark identifier **2016**.

The mounting structure **2030** is surrounded by a first covering **2018a** formed from a first material, such as an overmolding of VMQ silicone material #71385C available from Minnesota Rubber & Plastics, 1100 Xenium Lane N., Minneapolis, Minn. 55441. The first covering **2018a** shields the mounting structure and the components of the field generator from damage from impact during use, as well as from moisture during the autoclave process. Thus, the first material forming the first covering **2018a** is thermally-stable at temperatures up to the autoclave temperature, for example, 120 degrees Celsius. Additionally, the first material has suitable properties for water absorption, electrical conductivity, and thermal conductivity, such that the components of the electromagnetic field generator are not damaged by heat or moisture, and such that the operation of the components is not affected by contact with the first material. Suitable materials for the first covering **2018a** include titanium, ceramic, polypropylene (PP), polypropylene copolymer (PPCO), polycarbonate (PC), polymethylpentene (PMP), polytetrafluoroethylene (PTFE) resin, polymethyl methacrylate (PMMA or acrylic), ethylene tetrafluoroethylene (ETFE), ethylene chlorotrifluoroethylene (ECTFE), fluoro ethylene propylene (FEP), polyether imide (PEI), perfluoroalkoxy (PFA), polyketone (PK), polyphenylene oxide (PPO), polysulfone (PSF), polyvinyl chloride (PVC), polyvinylidene fluoride (PVDF), silicone, and thermoplastic elastomers (TPE), or combinations of these materials.

Optionally, the mounting structure **2030** can be covered with a compressible closed-cell foam material before applying the first covering **2018a**. For example, the compressible closed-cell foam material can be injection molded over the mounting structure **2030** such that the foam material fills any openings formed in the areas **2037**. The compressible foam material allows a user to comfortably grasp the landmark identifier **2016** and lowers the density of the landmark identifier compared to an implementation where silicone of the first covering **2018a** is molded directly over the mounting structure **2030**. The silicone or other material, as discussed above, of the first covering **2018a** can then be molded, or otherwise formed, over the foam. The closed-cell structure of the foam can limit the penetration of the silicone or other material of the first covering **2018a** into the foam to preserve the weight-reducing feature provided by the foam. In some implementations, grooves, channels, pockets or other features can be defined in the foam, and the first covering **2018a** can fill space of the features to increase the bond strength between the first covering and the foam, and to increase the strength of the landmark identifier **2016**.

Optionally, the housing **2018** also includes a second covering **2018b** that may provide an additional layer of protection or insulation, or aesthetic at an outer edge of the housing **2018**. The second covering **2018b** may be formed from a second material, such as an overmolding of VMQ silicone material #71325C available from Minnesota Rubber & Plastics, 1100 Xenium Lane N., Minneapolis, Minn. 55441. Alternatively, the second covering **2018b** can be formed of the materials discussed above with respect to the first covering **2018a**. Optionally, the second covering **2018b** and/or exposed parts of the first covering **2018a** can include

external surface texture formed over at least selected portions of the first covering **2018a** and/or the second covering **2018b** that are intended to be gripped by a user holding the landmark identifier **2016**. For example, a rough surface texture, ribs, dimples, bumps or other surface texture can be provided on the exterior of the second covering **2018b**. If desired, the external surface texture of the second covering **2018b** can be formed only in locations where the landmark identifier **2016** is intended to be gripped by a user. Thus, the external surface texture can indicate to a user where the landmark identifier **2016** should be gripped during use.

The housing **2018** also includes a coupling member **2018c** that passes through the internal body and that engages one or more attachable components. A drill sleeve attachment **2020**, as illustrated in FIG. **39b**, is coupled to the coupling member. Particularly, the drill sleeve attachment **2020** includes a shaft **2041** that is received in an opening **2035** (FIG. **39a**) of the mounting structure **2030**. The drill sleeve attachment also includes a frustoconical portion **2043** and a threaded portion **2045** that engage corresponding structures of the coupling member **2018c**, such as a frustoconical seat and an internal thread. Alternatively, the portion **2043** and corresponding seat can be formed with other matching geometries (e.g., cylindrical or conical) that assist in limiting play between, and securing, the location and orientation of the drill sleeve attachment **2020** relative to the coupling member **2018c**. Like the components of the electromagnetic field generator described above, the location and orientation of the coupling member **2018c** and the drill sleeve attachment **2020** and the drill sleeve **2022** impact the accuracy of the landmark identifier **2016** in use. Therefore, the coupling member **2018c** and the drill sleeve attachment **2020** and the drill sleeve **2022** are formed from dimension stable autoclavable materials as described, such as polysulfone, or non-magnetic metals such as cobalt chrome, titanium, or 300 series stainless steel. For example, the coupling member **2018c** and the drill sleeve attachment **2020** can be formed from GEHR PPSU polyphenylsulfone RAL 9005 Black (Solvay Radel R-5500) or equivalent. Alternatively, the coupling member **2018c** and the drill sleeve attachment **2020** can be formed of the dimension stable autoclavable materials discussed above with respect to the mounting structure **2030**. Also the coupling member **2018c** and the drill sleeve attachment **2020** and the drill sleeve **2022** can be an integral part of the landmark identifier **2016**.

The particular landmark identifier **2016** illustrated in FIG. **39** may also include the removable drill sleeve attachment **2020** and the drill sleeve **2022** with a serrated tip **2024**, though different components and constructions can be included as mentioned elsewhere. The sleeve attachment **2020** and drill sleeve **2022** can be formed as a single unit or as separate units connected to each other by adhesives or other connection means known to one skilled in the art. For illustration purposes, the sleeve **2022** as illustrated in FIG. **39** is a drill sleeve, but it can also be a larger size sleeve such as a screw driver sleeve or other sleeves as selected by the surgeon, or other components as disclosed herein. For example, various drill sleeves **2022** having different sizes may be used to accommodate different-sized drill bits, and drill sleeves **2022** having different lengths may be used to accommodate, for example, varying patient tissue thickness. To change sleeves or other components, the surgeon unscrews the sleeve attachment and replaces it with another sleeve attachment of choice and its corresponding sleeve. As discussed above, the drill sleeve **2022** and/or the screw driver sleeve can be used to gauge the depth of insertion of a drill bit or a fastener using reference markings formed in

the drill bit or on the screw driver and a reference portion of the landmark identifier. For example, when the drill sleeve **2022** is disposed against a bone, the opening of the landmark identifier through which the drill bit is inserted can serve as the reference portion.

Unlike the landmark identifier **18** illustrated in FIG. **9**, the landmark identifier **2016** depicted in FIGS. **39-40** does not require the second sensor **20** illustrated in FIG. **9** because the origin of the global space (the area in which the electromagnetic field is generated) can be defined within the landmark identifier **2016**. One axis of the global space co-ordinate system can be the longitudinal axis of the drill sleeve or other component **2022**. In that situation, the other two axes of the global space co-ordinate system can be defined by planes orthogonal to that longitudinal axis and to each other. Advantages of incorporating the field generator into the landmark identifier **2016** include a smaller size field generator because it can be brought into the local working space (area which may include the landmarks such as implant holes that are to be targeted for screw placement) therefore requiring a smaller electromagnetic field. The global space and local working space become the same or at least correspond more closely spatially when the landmark identifier **2016** with its field generator brought into the vicinity of the landmark, implant or probe sensor (not shown). Because the electromagnetic field size requirement is smaller, the induction coils within the field generator can be smaller which therefore reduces the size and weight of the handheld field generator to make it more manageable for handheld usage. In addition, use of the landmark identifier **2016** eliminates the necessity of X-ray devices for targeting of transfixion elements, such as radiation-emitting, fluoroscopic "c-arms," which have traditionally been used during tibial and femoral nail cases to achieve proper distal screw placement. A recent study quantified the impact the landmark identifier **2016** has on both radiation levels and case length. Use of the landmark identifier **2016** to achieve proper distal screw placement was shown to eliminate 36 seconds of fluoroscopy exposure (0.785 radiation absorbed doses, or rads) during tibial fracture cases and 49 seconds during femoral fracture cases (2.362 rads). In addition, the accuracy and the consistency in the degree of precision in targeting and locking of the distal screws offered by use of the landmark identifier **2016** reduced distal locking time by at least 50% when compared to, for example, c-arm techniques for targeting and locking the distal screws.

A light may be provided in an area of the landmark identifier/field generator/drill **2016**, such as the area **2025** to indicate to the user that power is being supplied to the landmark identifier/field generator/drill **2016**. In FIG. **41**, the drill sleeve **2022** has been removed and the landmark identifier **2016** has been engaged with a screw driver **2100** for fixing the implant to the bone. As shown in FIG. **41**, the housing **2018** of the landmark identifier **2016** may include one or more indentations **2018d** for finger placement to allow the user to comfortably place his or her hand around the landmark identifier **2016**. In the implementation depicted in FIG. **41**, there are six indentations. Additionally, the texture and dimension of an exterior surface of the housing **2018** can be configured allow a user to comfortably and securely grip the housing **2018**. Additionally, or alternatively, the landmark identifier **2016** can be attachable to a tool, such as being attachable to a housing of the screw driver **2100**.

The material selection for the landmark identifier **2016** of FIG. **39** which houses the field generator can be optimized for weight and stability after multiple autoclave cycles. Any

autoclavable material can be used, and the materials are preferably non-magnetic or weak magnetic to avoid or minimize interference with the electromagnetic fields. Exemplary materials include ceramic, autoclavable polymers such as polypropylene (PP), polypropylene copolymer (PPCO), polycarbonate (PC), polymethylpentene (PMP), polytetrafluoroethylene (PTFE) resin, polymethyl methacrylate (PMMA or acrylic), ethylene tetrafluoroethylene (ETFE), ethylene chlorotrifluoroethylene (ECTFE), fluoroethylene propylene (FEP), polyether imide (PEI), perfluoroalkoxy (PFA), polyketone (PK), polyphenylene oxide (PPO), polysulfone (PSF), polyvinyl chloride (PVC), polyvinylidene fluoride (PVDF), silicone, or thermoplastic elastomers (TPE), and still other autoclavable materials which will be apparent to those skilled in the art, including combinations of the above.

FIG. 42 illustrates another insertion handle 2122, an adjustable stop 1801, a probe 2129 and a sensor 2126 located within or on a body 2129a of the probe 2129. The insertion handle 2122 is removably attached to an orthopaedic implant, such as an intramedullary nail. The probe 2129 includes a cable 2130 and a connector 2131 for connection to a processor for use in targeting landmarks of the intramedullary nail, or other implant. The probe 2129 also includes a grip 2132 that secures the cable 2130 to the body 2129a to prevent tension forces applied to the cable 2130 from damaging the sensor 2126 and/or the electrical connection between the sensor 2126 and the cable 2130. The adjustable stop 1801 and an alternative stop 1803 are also illustrated in FIGS. 43 and 44. The stop 1801 and the stop 1803 each include a push button actuator 1802. The stop 1801 includes a thumb wheel 1806 that is used to turn a threaded bolt 1807 for attaching the stop 1801 to an insertion handle while the stop 1803 includes a knob clamp 1804 that is also connected to a threaded bolt 2531 (FIG. 58). The probe 2129 may be equipped with detents or markings to assist the user in placing the probe 2129 and sensor 2126 in the correct position.

The system may include different stops, such as stops 1801, 1803, depending upon the particular surgical approach contemplated. For example, the surgical approach in the case of retrograde placement of an intramedullary nail may utilize the stop 1801, whereas antegrade placement of an intramedullary nail may favor use of the stop 1803. Other surgical approaches may yet require other variations.

Now referring to FIG. 45, the adjustable stop 1803, an insertion handle 2123, and the probe 2129 are illustrated in an assembled configuration attached to an intramedullary nail 2125. A distal portion 2124 of the insertion handle 2123 is attached to a proximal head 2126 of the intramedullary nail 2125. The insertion handle 2123 is connected to the intramedullary nail 2125 through the use of a cannulated bolt (not shown). Alternatively, the insertion handle 2123 can be connected to the intramedullary nail 2125 using a quick-connect mechanism, or other attachment device.

The adjustable stop 1803 is attached to a proximal surface 2127 of the insertion handle 2123. The adjustable stop 1803 has a complimentary mating portion such that when the stop 1803 is connected to the insertion handle 2123, the stop 1803 is located or fixed relative to the insertion handle 2123 within three degrees of freedom. The probe 2129 is inserted through a hole 1805 of the adjustable stop 1803, through the distal portion 2124 of the insertion handle 2123, through the cannulated bolt, and into a cannulation (not shown) of the intramedullary nail 2125. The probe 2129 includes the sensor 2126 (FIG. 42) located proximate a distal end (not shown). The sensor 2126 (FIG. 42) is electrically connected

to the cable 2130 that includes the connector 2131 for transmitting signals from the sensor 2126 (FIG. 42) to a control unit (not shown).

FIG. 46 shows the adjustable stop 1801, the insertion handle 2122, and the probe 2129 in an assembled configuration attached to an intramedullary nail 2155. The adjustable stop 1801 is mounted to a proximal surface 2147 of the insertion handle 2122 by rotating the thumb wheel 1806 to thread the bolt 1807 (FIG. 43) into a threaded connection (not shown) formed in the insertion handle 2122. The adjustable stop 1801 has a complimentary mating portion such that when the stop 1801 is connected to the insertion handle 2122, the stop 1801 is located or fixed relative to the insertion handle 2122 within three degrees of freedom. A distal portion 2144 of the insertion handle 2122 is attached to a head 2156 of the intramedullary nail 2155. For example, the insertion handle 2122 is connected to the intramedullary nail 2125 through the use of a cannulated bolt (not shown). The probe 2129 is inserted through a hole 1808 of the adjustable stop 1801, through the distal portion 2144 of the insertion handle 2122, through the cannulated bolt, and into the head 2156 of the intramedullary nail 2155.

Now referring to FIG. 47, a proximal targeting probe 2161 and a distal targeting probe 2171 are illustrated. The proximal targeting probe 2161 includes a tape body 2163 and a sensor 2165 disposed within or on the tape body 2163 at a predetermined distance D1 from a reference point R1 of the body 2163. The proximal targeting probe 2161 also includes a color-coded grip 2167 that indicates that the probe 2161 is to be used for targeting proximal landmarks of an orthopaedic implant, such as the intramedullary nail 2155 of FIG. 46 and a cable 2169 for carrying a signal from the sensor 2165 to a control unit (not shown). The distal targeting probe 2171 includes a tape body 2173 that is longer than the body 2163 of the proximal targeting probe 2161. A sensor 2175 is included within or on the tape body 2173 at a second predetermined distance D2 from a reference point R2 of the body 2173. The distal targeting probe 2171 also includes a color-coded grip 2177 that is a different color than the grip 2167 and that indicates that the probe 2171 is to be used for targeting distal landmarks of an orthopaedic implant, such as the intramedullary nail 2155 of FIG. 46. A cable 2179 is included to transmit a signal from the sensor 2175 to a control unit (not shown). The tape body 2163 of the proximal targeting probe 2161 and/or the tape body 2173 of the distal targeting probe 2171 may have, in some implementations, a rectangular geometry that assists in orienting the tape body as it is placed into a cannulation of the intramedullary nail. An oval, square, or circular geometry also may be used. In some implementations, the tape body 2163 and the tape body 2173 may be a hollow metal tube. Instead of color-coded grips, in some implementations, each of the sensors 2165 and 2175 is connected to a Programmable Read-Only Memory (PROM) microchip that stores the calibration offset values and also stores an identifier that identifies whether the probe is used for proximal or distal targeting. In that way, when the sensors 2165 and 2175 are both connected to a processor, such as the processor 2327 of FIG. 51, the processor automatically identifies the type of targeting contemplated and may display such information on a display device, such as the display 2326.

The tape body 2163 and the tape body 2173 may include one or more bends to bias at least a portion of the tape body 2163 and the tape body 2173 against the wall of the cannulation of the orthopaedic implant. Biasing a portion of the tape body against the wall of the cannulation increases the repeatability of locating the sensors 2165 and 2175

relative to landmarks. Alternatively, the probes **2161** and/or **2171** could be formed having dimensions approximately equal to dimensions of the cannulation of the intramedullary nail or other implant with which they are intended to be used so that the proper location of the sensor within the cannulation can be repeatably achieved.

With reference to FIG. **48** and as an alternative to the pair of probes illustrated in FIG. **47**, a targeting probe **2181** can be used to target both distal and proximal landmarks of an orthopaedic implant. The probe **2181** is tubular and made from a non-magnetic metal, such as stainless steel. The probe **2181** includes a tape body **2183**, a first sensor **2185** disposed within a distal portion of the tape body **2183** and a second sensor **2186** disposed within a proximal portion of the tape body **2183**. The first sensor **2185** is located at a distance **D3** from a reference point **R3** of the body **2183**, which may be formed as a notch or detent, and the second sensor is located at a second distance **D4** from the reference point **R3**.

In use, the first sensor **2185** is used to target a distal landmark of an orthopaedic implant, such as a distal locking aperture of an intramedullary nail, and the second sensor **2186** is used to target a proximal landmark of the orthopaedic implant, such as a proximal locking aperture of the orthopaedic nail. In some implementations, the construction of the probe **2181** can be similar to the distal targeting probe **2171** (FIG. **47**), with the addition of the second sensor **2186**. The probe **2181** also includes a grip **2187**, which can be color-coded to be distinguishable from the distal targeting probe **2171**, and to indicate that the probe **2181** can be used to target both distal and proximal landmarks of an implant. As discussed above, each of the sensors **2185** and **2186** can be connected to a PROM or other storage device that stores reference values for use in determining a position of a landmark identifier, such as the landmark identifier **2016**, relative to a landmark of an implant. The PROMs also store identifiers that allow a processor to determine whether a received signal was generated by the distal sensor **2185** or the proximal sensor **2186**.

Another alternative probe **2191** is illustrated in FIG. **49**. The probe **2191** includes a housing **2192** and a retractable/extendible body **2193** that can be coiled within the housing **2192**. A sensor **2195** disposed within the body **2193** can be positioned at a first position **P1** for targeting a proximal landmark of an implant, and can be positioned at a second position **P2** for targeting a distal landmark of an implant. In some implementations, the body **2193** can be formed as a concave metal strip that tends to maintain a generally straight shape when extended from the housing, but can also be coiled within the housing **2192**. For example, the body **2193** may consist of layered, flexible stainless steel bi-stable spring bands that, when straightened, create tension within the springy metal bands to maintain a generally straight orientation, but coil within the housing **2192** when the tension is relieved. However, other types of materials can be used to form the body, including resilient plastic or rubber tubing or sheeting. Another alternative is to form the body **2192** from nested segments of tubing that can extend and retract by sliding within adjacent tube segments. The probe **2191** can include a rotary encoder, an optical device, or other measuring device or method to determine a length of the body **2193** that is currently extending from the housing **2192**. The determined length can be used to determine whether the sensor **2195** is positioned at a desired position, such as the first position **P1** or the second position **P2**.

Now referring to FIG. **50**, the adjustable stop **1801** is mounted to an alternative insertion handle **2210**. The inser-

tion handle **2210** includes a body **2211** that is engaged with the head **2156** of the intramedullary nail **2155** (also shown in FIG. **46**). As an example, a cannulated bolt (not shown) may be used to connect the insertion handle **2210** to the head **2156**. The insertion handle **2210** includes a sensor **2213** for use in targeting a proximal landmark of the nail **2155**, such as a proximal locking aperture **2157**. The sensor **2213** is located within or on the body **2211** at a predetermined distance **D5** from the proximal locking aperture **2157** when the insertion handle is attached to the nail **2155**. The sensor can be passive, or electrically powered by an internal battery (not shown) or an external power supply (not shown). The sensor **2213** may be mounted in a compartment that is unitary or integral with the body **2211**, such as the exterior compartment **2216**. Alternatively, the sensor **2213** can be located in an internal compartment **2213a**, shown in FIG. **51**. The insertion handle **2210** is made of plastic, but other materials could alternatively be used.

The adjustable stop **1801** is used with a probe, such as the probe **2129** (FIG. **46**), for targeting distal landmarks of the nail **2155**, such as a distal aperture **2159** (FIG. **51**). As described above, the adjustable stop **1801** can be attached to the insertion handle **2210** by a bolt **1807** (FIG. **43**) that engages a threaded bore **2215** that is aligned with a longitudinal through hole of the insertion handle **2210** (not shown) that allows the probe to pass through the insertion handle **2210** and into the cannulation **2155a** (FIG. **51**) of the nail **2155**. The adjustable stop **1801** also includes an arm **1809** that engages the body **2211** to prevent rotation between the adjustable stop **1801** and the insertion handle **2210**.

Although not illustrated, the adjustable stop **1803** (shown in FIG. **45**) can also be used with an insertion handle that includes an embedded sensor for targeting proximal landmarks of an implant.

In use, an orthopaedic implant, such as the intramedullary nail **2155**, is implanted into bone. The insertion handle **2210** may be connected to the orthopaedic implant before or after implantation. Thereafter, a landmark identifier can be used for targeting of the proximal landmarks of the orthopaedic implant.

In some implementations, the distal landmarks are targeted prior to the proximal landmarks. As before, the insertion handle **2210** may be connected to the orthopaedic implant before or after implantation. The stop **1801** or the stop **1803** is connected to the insertion handle **2210**. A probe is inserted into the stop, through the insertion handle **2210**, and into the orthopaedic implant, such as the nail **2155**. The distal landmarks are targeted, transfixion elements are placed in the distal landmarks to hold the orthopaedic implant, the probe is removed, and then the proximal landmarks are targeted.

Now referring to FIG. **51**, a system **2300** for targeting a blind landmark of an orthopaedic implant is illustrated. The system **2300** includes the adjustable stop **1801**, the probe **2171**, and the insertion guide **2210** assembled and connected to the intramedullary nail **2155**, which is implanted in a bone **B** that includes a fracture **F**. The intramedullary nail **2155** includes a distal aperture **2159** that extends through the intramedullary nail **2155** and is configured to receive a locking fastener (not shown). The probe **2171** is received through an aperture or the adjustable stop **1801**, through a cannulation **2210a** of the insertion handle **2210**, and within a cannulation **2155a** of the intramedullary nail **2155**. The probe **2171** is received within the stop **1801** such that the sensor **2175** is positioned at a known distance from the distal aperture **2159**. The known distance may range from zero to about 102 millimeters from the sensor **2175** to the distal

aperture **2159** or other landmark. In other implementations, the known distance may range from about two millimeters to about twenty-five millimeters or from about three millimeters to about ten millimeters. In the depicted implementation, the known distance is about five millimeters.

The system **2300** also includes a tool, such as a drill **2310** that includes a drill bit **2311**. The landmark identifier **2016** is engageable with the drill **2310** and/or the drill bit **2311** such that a position and orientation of the landmark identifier **2016** can be used to determine a position and orientation of the drill **2310** and/or the drill bit **2311**. For example, the housing of the landmark identifier **2016** can include a friction fit engagement with the drill **2310**, a strap, or other securing mechanism to at least temporarily secure the landmark identifier **2016** to the drill **2310**. In other implementations, the landmark identifier **2016** can be integrated with the drill **2310**, or other tool. In some implementations, the drill sleeve (not shown) may telescope to allow the user to place the tip of the drill sleeve against a patient and also allow the user to move the drill bit in a longitudinal direction for drilling.

A targeting system **2320** is operable to provide an indication to a user, such as a surgeon, of the relative position of a tool, such as a drill **2310** that includes a drill bit **2311**, relative to the distal aperture **2159**. The targeting system **2320** includes a housing **2321**, a first sensor port **2322**, a second sensor port **2323**, a field generator port **2324**, a display device **2325**, and a processor **2327**. The first sensor port **2322** is configured to receive a connector of the cable **2179** of the probe **2171** such that the targeting system **2320** receives signals generated by the sensor **2175**. The second sensor port **2323** is configured to receive a connector of a cable **2214** that is connected to the sensor **2213** of the insertion handle **2210** such that the targeting system **2320** receives signals generated by the sensor **2213**. The field generator port **2324** is configured to receive a connector of a cable **2019** of the landmark identifier **2016** such that the targeting system **2320** transmits signals via the cable **2019** to control the operation of the field generator of the landmark identifier **2016**. The display device **2325** is operable to output a display of a graphical user interface **2326** that includes a representation of the position and orientation of the drill **2310** relative to a location and orientation of a landmark of the intramedullary nail **2155**, such as the distal aperture **2159**, the proximal aperture **2157** (FIG. 50), or another landmark.

The processor **2327** is operable to receive signals from the distal sensor **2175** and/or the proximal sensor **2213**, and to determine, based on the received signal(s), a current position and orientation of the landmark identifier **2016** relative to a selected landmark of the intramedullary nail **2155**. For example, a feature of a signal received from the distal sensor **2175**, such as one or more induced electrical currents, can be used by the processor **2327** to determine a distance of the landmark identifier **2016** from the sensor **2175**, as well as an orientation of a magnetic moment of a field generated by the landmark identifier **2016**. For example, the sensor **2175** can transmit a signal indicative of a current value and an identifier that indicates which of a plurality of induction coils produced the associated current value. The processor **2327** can compare the received current values with reference values associated with each of the induction coils to determine differences between the received values and the reference values. The reference values can be values of induced current associated with a reference field generation signal, a reference position, and a reference orientation of the landmark identifier **2016**. The processor **2327** uses these deter-

mined differences between the received and reference values to determine a difference in position and orientation of the landmark identifier **2016** from the reference position and orientation based on any determined difference in the magnetic field generated by the landmark identifier **2016** from the reference field. Based on the difference in position and orientation of the landmark identifier **2016** and the reference position and orientation, a current position and orientation of the landmark identifier **2016** relative to the sensor **2175** can be determined by the processor **2327**.

The current distance and orientation of the landmark identifier **2016** relative to the sensor **2175** are used by the processor **2327** to determine the current distance of the landmark identifier **2016** from the distal aperture **2159** and the current relative orientation of the magnetic moment of the generated magnetic field relative to a central through-axis of the distal aperture **2159**. For example, the processor **2327** determines the current distance and relative orientation of the landmark identifier **2016** relative to the distal aperture **2159** based on a known position and orientation of the distal aperture **2159** relative to the distal sensor **2175**. The processor **2327** also determines a current position of the drill **2310**, including the drill bit **2311**, from the distal aperture **2159** as well as a current orientation of the drill **2310** and the drill bit **2311** relative to the central through-axis of the distal aperture **2159** based on a known position and orientation of the drill **2310** and the drill bit **2311** relative to the location of the landmark identifier **2016** and the magnetic moment of the field generated by the landmark identifier **2016**. In the case of the landmark identifier **2016**, a longitudinal axis of the drill bit **2311** is coaxial with the magnetic moment of the magnetic field generated by the landmark identifier **2016**.

The graphical user interface **2326** is generated by the processor based on the determined current position and orientation of the drill **2310** and the drill bit **2311** relative to the distal aperture **2159**, or based on a current position and orientation of another tool relative to another landmark. The graphical user interface **2326** includes a first portion **2326a** that includes an intramedullary nail image **2155b** that represents the intramedullary nail **2155** and includes a distal aperture image **2159a** that represents the distal aperture **2159**. The first portion **2326a** of the graphical user interface **2326** also includes an orientation indicator **2330** that includes a first circle **2331**, a second circle **2333**, and a line **2335** that intersects the centers of each of the first circle **2331** and the second circle **2333**. The line **2335** provides an illustration to the user of the current orientation of the drill bit **2311** relative to the central through axis of the distal aperture **2159**. Particularly, when the first circle **2331** and the second circle **2333** are both disposed entirely within the distal aperture image **2159a**, then the longitudinal axis of the drill bit **2311** is co-axial with the central through axis of the distal aperture **2159**, as shown in FIG. 51. The graphical user interface **2326** also includes a second portion **2326b** that includes intramedullary nail image **2155b** and a drill bit image **2331b**. The current position and orientation of the drill bit **2311** relative to the intramedullary nail **2155** is illustrated in the second portion **2326b** of the graphical user interface **2326**.

In use, the probe **2155**, the insertion handle **2210**, the adjustable stop **1801**, the landmark identifier **2016**, the drill **2310**, and the drill bit **2311** can be sterilized, such as by autoclaving, if one or more of the components is not sterile. When sterile, the probe **2155** is connected with the first sensor port **2322** of the targeting system **2320** and the insertion handle **2210** is connected with the second sensor port **2323** of the targeting system **2320**. The processor **2327**

detects the connection of the distal sensor **2175** and the proximal sensor **2213** and can optionally cause a display of an indication of the proper (or improper) connection of the probe **2155** and the insertion handle **2210** and/or an indication of the proper (or improper) operation of the distal sensor **2175** and the proximal sensor **2213**. Similarly, the landmark identifier **2016** is connected with the field generator port **2324**, and the processor can detect the connection of the landmark identifier **2016** and cause a display of the proper (or improper) connection of the landmark identifier **2016** and/or the proper (or improper) operation of the field generator of the landmark identifier **2016**. The sensor **2175** is connected to a Programmable Read-Only Memory (PROM) microchip that stores the calibration values and also stores an identifier that identifies the sensor **2175** as a distal targeting sensor. When the sensor is connected to the processor **2327**, the processor **2327** automatically identifies the type of targeting contemplated and may display an indication on graphical user interface **2326** that a sensor of the identified type is connected.

The insertion handle **2210** is engaged with the intramedullary nail **2155** and the adjustable stop **1801** is engaged with the insertion handle **2210**. The probe **2155** is then inserted in the adjustable stop **1801** and positioned at a desired location. The button **1802** is manipulated to allow the probe **2155** to be adjusted, and the button **1802** is released to clamp the probe **2155** in a desired position. For example, the probe **2155** can be inserted until a reference mark, such as a printed mark or a detent or other structure of the probe **2155** is correctly positioned relative to a reference portion of the adjustable stop **1801**. The positioning of the probe **2155** locates the distal sensor **2175** in the correct position relative to the distal aperture **2159**.

A drill sleeve **2022** is selected and engaged with the drill sleeve attachment **2020** of the landmark identifier **2016**. For example, one of a short drill sleeve and a long drill sleeve is selected. An indication of the selection is input to the targeting system **2320**, such as by interaction with a menu **2326c** of the graphical user interface **2326**. Additionally, an indication of the specific intramedullary nail **2155**, insertion handle **2210**, adjustable stop **1801**, and/or probe **2171** is input to the targeting system **2320**, if not automatically recognized by the targeting system **2320** and/or to confirm the specific intramedullary nail **2155**, insertion handle **2210**, adjustable stop **1801**, and/or probe **2171**.

The accuracy of the targeting system **2320** is checked before implantation of the intramedullary nail **2155** by placing the landmark identifier **2016** directly over the distal aperture **2159** of the intramedullary nail **2155**, which can be done by inserting the tip **2024** of the drill sleeve **2022** within the distal aperture **2159**. If the second circle **2333** is shown within the distal aperture image **2159a**, and if the orientation of the line **2335** corresponds to the orientation of the drill sleeve **2022**, then the targeting system **2320** is accurate. If the targeting system is not accurate, the input indications of selected components, and/or the position of the probe **2171** are checked. If no errors are found, then the targeting system **2320** is recalibrated, as described below with reference to FIG. **52**.

When the components are assembled and checked as described above, the intramedullary nail **2155** is implanted in the bone B. When the intramedullary nail **2155** is located in the desired position, the tip **2024** of the drill sleeve **2022** is placed over the distal aperture **2159**. When the landmark identifier **2016** is brought near the sensor **2175**, a signal generated by the sensor **2175** is received by the processor **2327**, and one or more signal feature, such as a current value,

and an identifier are used by the processor to determine that distal targeting is being attempted, and the targeting system **2320** enters a distal targeting mode. Locating the tip **2024** relative to the distal aperture **2159**, which is hidden within the bone B, is performed by a user by making reference to the graphical user interface **2326** in the distal targeting mode, and is confirmed when the first circle **2331** and the second circle **2333** are located within the distal aperture image **2159a**.

An incision is made in the skin at the location of the distal aperture **2159**. The drill sleeve **2022** is then inserted into the incision down to the bone B. The landmark identifier **2016** is then manipulated by a user to arrange both the first circle **2331** and the second circle **2333** completely within the distal aperture image **2159a** and, while maintaining the position and orientation of the landmark identifier **2016**, the drill bit **2311** is inserted through the drill sleeve **2022** and a user drills through the bone B, through the distal aperture **2159**, to the cortex on the far side of the bone B. A desired drill depth can be achieved by the user by referring to the second portion **2326b**, or by comparing one or more reference marks included on the drill bit **2311** to a reference portion of the landmark identifier **2016**.

The drill bit **2311** is then removed and a locking fastener (not shown) is engaged with the bone B and the distal aperture **2159** through the drill sleeve **2022**, again maintaining the first circle **2331** and the second circle **2333** within the distal aperture image **2159a**. A desired depth of insertion of the locking fastener can be achieved by a user by referring to the second portion **2326b** of the graphical user interface **2326**, or by comparing a reference marking on a fastener driving tool (not shown) to a reference portion of the landmark identifier **2016**, as described above.

In addition to engaging the locking fastener with the distal aperture **2159**, the targeting system **2320** can be used to target a proximal landmark of the intramedullary nail **2155**. For example, before or after engaging the locking fastener with the distal aperture **2159** and the bone B, a user can select the sensor **2213** from the menu **2326c** or move the landmark identifier **2016** within a predetermined distance of the sensor **2213**, which causes the targeting system **2320** to enter a proximal targeting mode and output a display of the relative position and orientation of the drill **2300** and/or the drill bit **2016** relative to a proximal landmark of the intramedullary nail **2155**, such as the proximal aperture **2157** (FIG. **50**). A user can then engage a fastener or other tool or implant with the proximal landmark in a manner similar to that described above with respect to drilling through the distal aperture **2159** and/or engaging the locking fastener with the distal aperture **2159**.

As mentioned above, a proximal landmark can be targeted using the targeting system **2320** and the sensor **2213** before or after targeting a distal landmark, such as the distal aperture **2159**. Particularly, a proximal landmark can be targeted before insertion of the probe **2171** within the adjustable stop **1801**, the insertion handle **2210**, and/or the intramedullary nail **2155**. The proximal landmark can also be targeted after removal of the probe **2171**, or while the probe **2171** is inserted within the adjustable stop **1801**, the insertion handle **2210**, and/or the intramedullary nail **2155**. For example, as discussed above, the probe **2171** can be inserted through a portion of the intramedullary nail **2155** that does not interfere with engagement of the drill bit **2311** or the fastener with a proximal aperture or other proximal landmark. Additionally, if the probe **2171** is inserted into the cannulation **2155a** and the proximal aperture also passes through the cannulation **2155a**, the cannulation **2155a** can

be large enough to simultaneously accommodate both a fastener or the drill bit 2311 and the probe 2171. For example, the probe 2171 can be dimensioned to be disposed in a gap between the drill bit 2311 and an inner wall of the intramedullary nail 2155 that defines the cannulation 2155a. Similarly, the probe 2181 (FIG. 48), which has both the distal sensor 2185 and the proximal sensor 2186, can be inserted in the cannulation 2155a and both distal and proximal landmarks of the intramedullary nail 2155 can be targeted without removal or adjustment of the probe 2181.

Alternatively, a proximal landmark of the intramedullary nail 2155 can be targeted using the targeting system 2320 and either the sensor 2175 of the probe 2171 or the sensor 2165 of the probe 2161 (FIG. 47). For example, after engaging the locking faster with the distal aperture 2159, the probe 2171 can be adjusted using the adjustable stop 1801 to secure the sensor 2175 in a predetermined location relative to one or more proximal landmarks of the intramedullary nail 2155. The menu 2326c can then be used to select a proximal targeting mode such that the targeting system 2320 is operable to display a position and orientation of the drill 2310 and/or the drill bit 2311 (or other tool or implant) relative to the proximal landmark(s). Similarly, and particularly where it is undesirable to have a portion of the probe 2171 extending a distance from the adjustable stop 1801, the probe 2161 can be connected to the targeting system 2320 and inserted in the adjustable stop 1801 such that the sensor 2165 is located in a known location relative to one or more proximal landmarks of the intramedullary nail 2155. In either case, one or more proximal landmarks of the intramedullary nail can then be targeted using the targeting system 2320, as described above. In other implementations, the proximal landmark(s) can be targeted before the distal aperture 2159 using the probe 2171 or the probe 2161.

Now referring to FIG. 52, a calibration member 2340 is attached to the landmark identifier 2016 and the intramedullary nail 2155 for use in calibrating the targeting system 2320. For example, if the accuracy of the targeting system 2320 is checked before inserting the intramedullary nail 2155 and errors are found, the targeting system 2320 can be re-calibrated. In use, the calibration member 2340 is engaged with the landmark identifier 2016. Then a tip 2341 is inserted into the distal aperture 2159 until a reference portion (not shown) of the calibration member 2340 abuts the intramedullary nail 2155. Re-calibration of the targeting system 2320 can then be achieved by interaction with the menu 2326c of the graphical user interface 2326. For example, a "re-calibrate" option may be selected from the menu 2326c, which causes the targeting system 2320 to transmit a driving signal to the field generator of the landmark identifier 2016 and to store as reference values any current values received from the sensor 2175 of the probe 2171. The graphical user interface 2326 can display an indication of a successful re-calibration of the targeting system 2320.

Now referring to FIGS. 53-57, details of the adjustable stop 1801 are illustrated. The adjustable stop 1801 includes a housing 2401 that includes a clamp member slot 2402. A clamp member 2411 is received within the clamp member slot 2402 and is biased by a spring 2413. The clamp member 2411 is retained within the housing 2401 by pins 2415. The clamp member 2411 also includes an actuator slot 2417, a linkage aperture 2418, and a probe aperture 2419.

The button 1802 includes an actuating shaft 2421 and an actuating slot 2423. The actuating shaft 2421 is received within an aperture 2405 of the housing 2401 and is biased against insertion into the housing by a spring 2425. When

assembled, the actuating shaft 2421 is received in the actuator slot 2417 of the clamp member 2411 and is retained in the housing 2401 by a linkage pin 2427 that is inserted into the actuating slot 2423 of the actuating shaft 2421 through an opening 2403 of the housing 2401 and through the linkage aperture 2418 of the clamp member 2411. In use, when the button 1802 is depressed against the biasing force of the spring 2425, the linkage pin 2427 is moved within the actuating slot 2423 which pushes the clamp member 2411 against the spring 2413 to allow a probe to be inserted into the hole 1808 and through the probe aperture 2419. When the probe is inserted and the button 1802 is released, the springs 2413 and 2425 cause the clamp member 2411 to bear against the probe to maintain the position of the probe within the hole 1808.

The thumb wheel 1806 is received within a thumb wheel slot 2407 of the housing 2401 and the bolt 1807 is threaded into a threaded aperture 2431 of the thumb wheel 1806 through a bolt aperture 2409 of the housing 2401. After the bolt 1807 is threaded into the bolt aperture 2431, a pin 2433 is inserted through an aperture 2435 (FIG. 56) of the thumb wheel 1806 and into a slot 2437 (FIG. 56) of the bolt 1807 to retain the bolt 1807 in engagement with the thumb wheel 1806.

Now referring to FIGS. 58-62, details of the adjustable stop 1803 are illustrated. The adjustable stop 1803 includes a housing 2501 that includes a clamp member slot 2502. A clamp member 2511 is received within the clamp member slot 2502 and is biased by a spring 2513. The clamp member 2511 is retained within the housing 2501 by pins 2515. The clamp member 2511 also includes an actuator slot 2517, a linkage aperture 2518, and a probe aperture 2519.

The button 1802 includes an actuating shaft 2421 and an actuating slot 2423. The actuating shaft 2421 is received within an aperture 2405 of the housing 2401 and is biased against insertion into the housing by a spring 2525. When assembled, the actuating shaft 2421 is received in the actuator slot 2517 of the clamp member 2511 and is retained in the housing 2501 by a linkage pin 2527 that is inserted into the actuating slot 2423 of the actuating shaft 2421 through an opening 2503 of the housing 2401 and through the linkage aperture 2418 of the clamp member 2511. In use, when the button 1802 is depressed against the biasing force of the spring 2525, the linkage pin 2527 is moved within the actuating slot 2423 which pushes the clamp member 2511 against the spring 2513 to allow a probe to be inserted into the hole 1805 and through the probe aperture 2519. When the probe is inserted and the button 1802 is released, the springs 2513 and 2525 cause the clamp member 2511 to bear against the probe to maintain the position of the probe within the hole 1805.

A threaded bolt 2531 of the clamp knob 1804 is threaded into a bolt aperture 2509 of the housing 2501 to secure the adjustable stop 1803 to an insertion handle.

System calibration may be accomplished during manufacturing, after distribution, or immediately preceding implant implantation. The calibration step is analogous to registration in computer assisted surgery. Calibration may be needed for different reasons. For example, sensor calibration may be needed to correct for manufacturing tolerances. The system may be designed based upon a computer-aided-design model, and calibration is used to accurately place the sensors relative to one another. The processor or the control unit may include software to generate X, Y, Z, pitch, yaw, and roll offset values to locate the sensors in a global coordinate system or simply placement relative to one another. The system may be manufactured and calibrated

during manufacturing and assigned a unique identifier, such as a serial number, color code, bar code, or RFID tag. If the system needs to be re-calibrated, the unique identifier may be used to retrieve the offset values, either locally or over a network. Further, the unique identifier may be used to retrieve other data, such as the size of the intramedullary nail or the length of the intramedullary nail and/or the probe.

The systems for identifying a landmark may be used for other purposes beyond targeting blind screw holes of an implanted intramedullary nail. These include, but are not limited to, targeting blocking screws and aligning guide pins. In one procedure, blocking (poller) screws can be inserted into the bone directly outside and tangent to the nail or rod. Targets are shown as two lines on the screen on opposing sides of the nail, such as anterior-posterior or medial-lateral, and offset from the nail at a distance, for example, 2.5 mm. The surgeon aligns the landmark identifier to one of the lines as determined by anatomical side where he or she wishes to place the blocking screw. Other symbols or indicia such as dots, bull's-eyes or combinations thereof can be used as targets shown on the screen. For this application, devices that are insertable in the medullary canal and instrumented with a sensor or sensors can be used as a means to target blocking screws, including but not limited to, a probe, a reducer or an awl. The depicted systems for identifying a landmark can also be used to align or center a guide pin in both A-P and M-L planes for placement of a lag screw in the proximal portion of a femoral nail. An exemplary implementation of this system may include a sensor placed with known orientation and location relative to and in the insertion handle and/or drill guide and/or alignment jig which is removably attached to the proximal portion of the femoral nail.

While FIG. 1 illustrates a pocket for affixing the first sensor to the implant, other structure and/or methods may be used to affix these items together. For example, probes of varying length may be used to place the first sensors in the appropriate position as illustrated in FIG. 42. The adjustable stops 1801, 1803 of FIGS. 41-42 may be used to precisely position the sensor 2126 in the implant 30.

While only certain implementations have been set forth, alternatives and modifications will be apparent from the above description to those skilled in the art. These and other alternatives are considered equivalents and within the spirit and scope of this disclosure and the appended claims.

The invention claimed is:

1. A method comprising:

sterilizing a landmark identifier with autoclave sterilization, the landmark identifier comprising a plurality of magnetic field generating elements mounted to an internal mounting structure;

after sterilizing the landmark identifier, using the landmark identifier to identify one or more landmarks of an orthopaedic implant; and

after using the landmark identifier to identify the one or more landmarks of the orthopaedic implant, sterilizing the landmark identifier with autoclave sterilization.

2. The method of claim 1, wherein sterilizing the landmark identifier with autoclave sterilization comprises placing the landmark identifier in an environment having a temperature of at least 120 degrees Celsius.

3. The method of claim 1, wherein sterilizing the landmark identifier with autoclave sterilization comprises sterilizing a landmark identifier comprising a plurality of receiving elements defined in the internal mounting structure, the magnetic field generating elements being mounted to the mounting structure at the respective receiving elements, the

internal mounting structure being configured to maintain a predetermined position and orientation of the magnetic field generating elements relative to each other during the autoclave sterilization.

4. The method of claim 1, wherein using the landmark identifier to identify one or more landmarks of an orthopaedic implant comprises:

placing the landmark identifier near a sensor such that the sensor produces sensor data based on a magnetic field produced by the landmark identifier; and

using a display of a targeting system to position the landmark identifier in a predetermined position relative to the one or more landmarks, the display indicating a position of an instrument determined based on the sensor data.

5. The method of claim 1, wherein using the landmark identifier to identify one or more landmarks of an orthopaedic implant comprises:

placing the landmark identifier near a sensor coupled to an intramedullary nail, such that the sensor produces sensor data in response to a sequence of magnetic field distributions generated by the magnetic field generating elements of the landmark identifier; and

aligning a drill guide with an axis of a distal hole of the intramedullary nail based on a display of a targeting system that receives the sensor data and that displays a position of the landmark identifier relative to the distal hole of the intramedullary nail based on the sensor data.

6. A method comprising:

obtaining a landmark identifier comprising a housing and a plurality of magnetic field generating elements that are mounted to an internal mounting structure within the housing;

sterilizing the landmark identifier with an autoclave sterilization process that provides pressure, humidity, and a temperature of at least 120 degrees Celsius; and after sterilizing the landmark identifier, providing the sterilized landmark identifier for use in a surgical procedure.

7. The method of claim 6, wherein obtaining the landmark identifier comprises obtaining a landmark identifier comprising a mounting structure comprising a plurality of receiving elements having the magnetic field generating elements mounted on or in the receiving elements, the plurality of receiving elements being disposed on the mounting structure at particular locations and orientations relative to each other; and

wherein providing the sterilized landmark identifier comprises providing the sterilized landmark identifier with the receiving elements in the particular locations and orientations relative to each other after sterilizing the landmark identifier.

8. The method of claim 6, wherein obtaining the landmark identifier comprises obtaining a landmark identifier wherein the mounting structure that has a flexural strength of at least 10,000 psi.

9. The method of claim 6, wherein obtaining the landmark identifier comprises obtaining a landmark identifier having the magnetic field generating components mounted on the mounting structure such that the autoclave sterilization process does not change the orientations of the magnetic field generating components by more than 2 degrees.

10. The method of claim 6, wherein obtaining the landmark identifier comprises obtaining a landmark identifier having the magnetic field generating components mounted on the mounting structure such that the autoclave steriliza-

41

tion process does not change the locations of the electromagnetic field generating components by more than 0.005 inches.

11. The method of claim 6, wherein obtaining the landmark identifier comprises obtaining a landmark identifier having a silicone outer covering.

12. The method of claim 6, wherein sterilizing the landmark identifier with the autoclave sterilization process comprises directly exposing the landmark identifier to the pressure, humidity, and temperature of the autoclave process.

13. The method of claim 6, further comprising placing: placing the landmark identifier near a sensor such that the sensor produces sensor data based on a magnetic field produced by the landmark identifier; and using a display of a targeting system to position the landmark identifier in a predetermined position relative to the one or more landmarks, the display indicating a position of an instrument determined based on the sensor data.

14. A field generator for use in a surgical targeting system, the field generator comprising:

a mounting structure comprising receiving elements disposed on the mounting structure at locations and orientations relative to each other;

magnetic field generating components received in the receiving elements, the electromagnetic field generating components being configured to produce a sequence of multiple different magnetic field distributions; and

42

a housing that extends around the mounting structure and the magnetic field generating elements,

wherein the mounting structure is configured to maintain the positions of the receiving elements within a predetermined tolerance relative to each other after the field generator is subjected to one or more autoclave sterilization processes.

15. The field generator of claim 14, wherein the mounting structure has one or more recessed portions.

16. The field generator of claim 14, wherein the magnetic field generating components are inductive coils.

17. The field generator of claim 14, wherein the housing comprises a covering that includes a silicone material.

18. The field generator of claim 14, wherein the mounting structure that has a flexural strength of at least 10,000 psi.

19. The field generator of claim 14, wherein the mounting structure is configured to maintain positions of the magnetic field generating elements such that autoclave sterilization does not change the orientations of the magnetic field generating components by more than 2 degrees.

20. The field generator of claim 14, wherein the mounting structure is configured to maintain positions of the magnetic field generating elements such that autoclave sterilization does not change the locations of the electromagnetic field generating components by more than 0.005 inches.

* * * * *

专利名称(译)	用于识别地标的系统和方法		
公开(公告)号	US9763598	公开(公告)日	2017-09-19
申请号	US14/937454	申请日	2015-11-10
[标]申请(专利权)人(译)	史密夫和内修有限公司		
申请(专利权)人(译)	施乐辉, INC.		
当前申请(专利权)人(译)	施乐辉, INC.		
[标]发明人	RITCHEY NICHOLAS S WILHELM HOA LA GRUSIN NATHANIEL KELLEY		
发明人	RITCHEY, NICHOLAS S. WILHELM, HOA LA GRUSIN, NATHANIEL KELLEY		
IPC分类号	A61B5/06 H01F41/00 A61L2/08 A61L2/07 A61B17/17 A61B5/11 A61B5/05 A61B17/72 A61B34/20 A61B90/00 A61B5/00		
CPC分类号	A61B5/061 A61B5/05 A61B5/06 A61B5/1127 A61B17/1703 A61B17/1707 A61B17/7233 A61B34/20 A61B90/39 A61L2/07 A61L2/081 H01F41/00 A61B5/4504 A61B17/1725 A61B2034/256 A61B2034 /2051 A61B2034/2072 A61B2090/0813 A61B2090/363 A61B2090/3958 Y10T29/4902 A61B2090/397		
优先权	12/768689 2015-02-03 US 12/547716 2014-07-22 US 61/173069 2009-04-27 US		
其他公开文献	US20160058321A1		
外部链接	Espacenet USPTO		

摘要(译)

公开了一种用于外科手术靶向系统的场发生器。场发生器包括安装结构，该安装结构包括被配置为接收电磁场发生器的组件的元件。元件在相对于彼此的位置和取向上设置在安装结构上。场发生器包括形成在安装结构上的至少一个覆盖物，其中，在使用中，元件相对于彼此的位置和取向在暴露于一个或多个灭菌过程之后保持基本上不变。

