



US009980660B2

(12) **United States Patent**  
**Rudy et al.**

(10) **Patent No.:** **US 9,980,660 B2**  
(45) **Date of Patent:** **\*May 29, 2018**

(54) **SYSTEMS AND METHODS FOR ON-SITE AND REAL-TIME ELECTROCARDIOGRAPHIC IMAGING (ECGI)**

(58) **Field of Classification Search**  
CPC ..... A61B 5/04085; A61B 5/04012; A61B 5/6805; A61B 6/503; A61B 2018/00839;  
(Continued)

(71) Applicant: **WASHINGTON UNIVERSITY IN ST. LOUIS**, St. Louis, MO (US)

(56) **References Cited**

(72) Inventors: **Yoram Rudy**, St. Louis, MO (US);  
**Yong Wang**, St. Louis, MO (US)

U.S. PATENT DOCUMENTS  
5,146,926 A 9/1992 Cohen  
5,483,968 A 1/1996 Adam et al.  
(Continued)

(73) Assignee: **Washington University in St. Louis**, St. Louis, MO (US)

FOREIGN PATENT DOCUMENTS

(\*) Notice: Subject to any disclaimer, the term of this patent is extended or adjusted under 35 U.S.C. 154(b) by 0 days. days.

JP 1987217936 A 9/1987  
WO 2007013994 2/2007

This patent is subject to a terminal disclaimer.

OTHER PUBLICATIONS

(21) Appl. No.: **14/990,469**

He, et al., "Noninvasive Imaging of Cardiac Transmembrane Potentials Within Three-Dimensional Myocardium by Means of a Realistic Geometry Anisotropic Heart Model"; IEEE Transactions on Biomedical Engineering; 2003 pp. 1190-1202; vol. 50; No. 10.  
(Continued)

(22) Filed: **Jan. 7, 2016**

(65) **Prior Publication Data**  
US 2016/0113543 A1 Apr. 28, 2016

*Primary Examiner* — Mark W Bockelman  
(74) *Attorney, Agent, or Firm* — Tarolli, Sundheim, Covell & Tummino LLP

**Related U.S. Application Data**

(63) Continuation of application No. 13/058,520, filed as application No. PCT/US2009/053262 on Aug. 10, 2009, now Pat. No. 9,259,166.  
(Continued)

(57) **ABSTRACT**

(51) **Int. Cl.**  
**A61B 5/0408** (2006.01)  
**A61B 5/04** (2006.01)  
(Continued)

A non-transitory computer readable medium stores instructions that, when executed by at least one processor, cause the at least one processor to perform a method that includes computing a transfer matrix representing a relative influence that each respective electrode location for measuring electrical potentials on a patient's body has on an estimation of electrical potentials for locations on a surface of interest prior to the measuring of electrical potentials at the respective electrode locations and receiving electrical potential measurements measured via a plurality of electrodes at respective electrode locations on the patient's body. The method also includes computing the estimation of electrical potentials for the locations on the surface of interest based  
(Continued)

(52) **U.S. Cl.**  
CPC ..... **A61B 5/04085** (2013.01); **A61B 5/04012** (2013.01); **A61B 5/6805** (2013.01);  
(Continued)

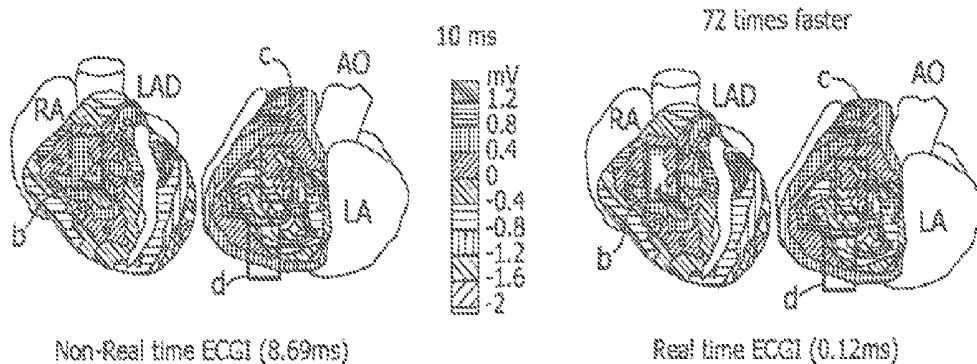

at least in part on the received electrical potential measurements and the computed transfer matrix and generating image data representing the estimation of electrical potentials.

7,016,719	B2	3/2006	Rudy et al.	
9,259,166	B2 *	2/2016	Rudy .....	A61B 5/04085
2002/0128565	A1	9/2002	Rudy	

**21 Claims, 20 Drawing Sheets**

**Related U.S. Application Data**

- (60) Provisional application No. 61/087,875, filed on Aug. 11, 2008.
- (51) **Int. Cl.**  
*A61B 5/00* (2006.01)  
*A61B 6/00* (2006.01)  
*A61B 8/08* (2006.01)  
*A61B 18/00* (2006.01)
- (52) **U.S. Cl.**  
 CPC ..... *A61B 6/503* (2013.01); *A61B 6/5247* (2013.01); *A61B 8/0883* (2013.01); *A61B 8/5261* (2013.01); *A61B 2018/00839* (2013.01)
- (58) **Field of Classification Search**  
 CPC ... *A61B 8/0883*; *A61B 8/5261*; *A61B 6/5247*  
 See application file for complete search history.

**References Cited**

U.S. PATENT DOCUMENTS

6,047,206	A	4/2000	Albrecht et al.
6,772,004	B2	8/2004	Rudy et al.
6,839,588	B1	1/2005	Rudy et al.
6,856,830	B2	2/2005	He
6,975,900	B2	12/2005	Rudy et al.

OTHER PUBLICATIONS

Sapp, et al., "Inverse Solution Electrocardiographic Mapping of Epicardial Pacing Correlates with Three-Dimensional Electroanatomic Mapping"; *Computers in Cardiology*; 2007; pp. 769-772; vol. 34.

European Search Report for EP0807119 dated Dec. 14, 2012; 8 pages.

Wang, et al. Focal atrial tachycardia after pulmonary vein isolation: Noninvasive mapping with electrocardiographic imaging (ECGI), *Heart Rhythm*, 2007, pp. 1081-1084, vol. 4, No. 8.

Ghanem et al., "Noninvasive Electrocardiographic Imaging (ECGI): Comparison to Intraoperative Mapping in Patients", *Heart Rhythm Journal*, 2005, pp. 339-354, vol. 2.

Intini et al., "Electrocardiographic Imaging (ECGI) a Novel Diagnostic Modality used for Mapping of Focal Left Ventricular Tachycardia in a Young Athlete", *Heart Rhythm*, 2005, pp. 1250-1252, vol. 2.

Jia et al., "Electrocardiographic Imaging of Cardiac Resynchronization Therapy in Heart Failure: Observation of Variable Electrophysiologic Responses", *Heart Rhythm*, 2006, pp. 296-310, vol. 3.

Ramanathan et al., "Noninvasive Imaging for Cardiac Electrophysiology and Arrhythmia", *Nature Medicine*, 2004, 7 pages.

Ramanathan et al., "Activation and Repolarization of the Normal Human Heart under Complete Physiological Conditions", *Proc. Natl. Acad. Sci., U.S.A. (PNAS)*, 2006, pp. 6309-6314, vol. 103.

Beyond the EKG, to a Hypersensitive Heart Monitor, *New York Times*, Apr. 22, 2004.

Wang, et al., "Noninvasive Electrocardiographic Imaging (ECGI) of Scar-Related Atypical Flutter" *Heart Rhythm*, 2007, pp. 1565-1567. Translation of Japanese Office Action; Japanese Patent Application No. 2011-523065; Filed Aug. 10, 2009; Representative: Takuji Yamada, dated Nov. 5, 2013; 2 pgs.

\* cited by examiner

FIG. 1

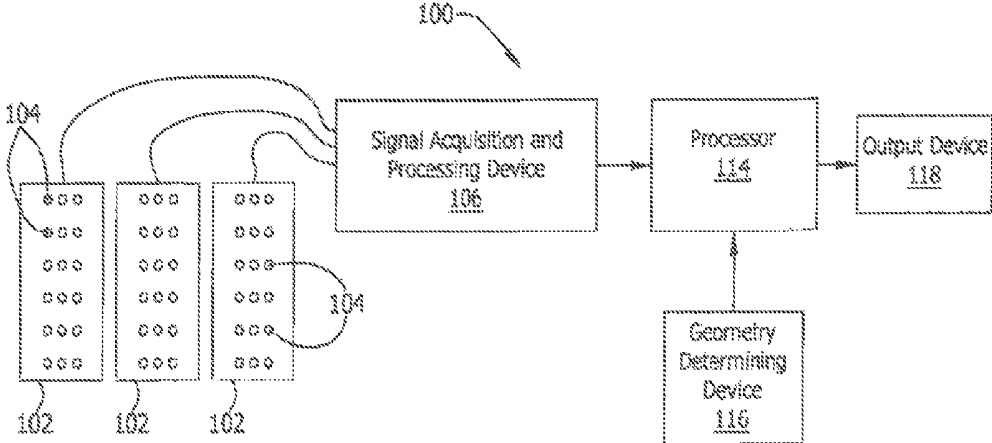

FIG. 2A

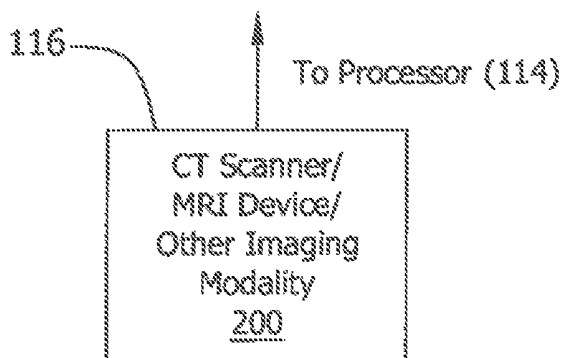

FIG. 2B

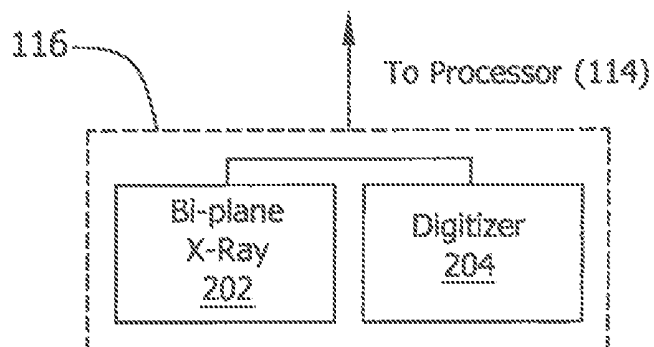

FIG. 3A

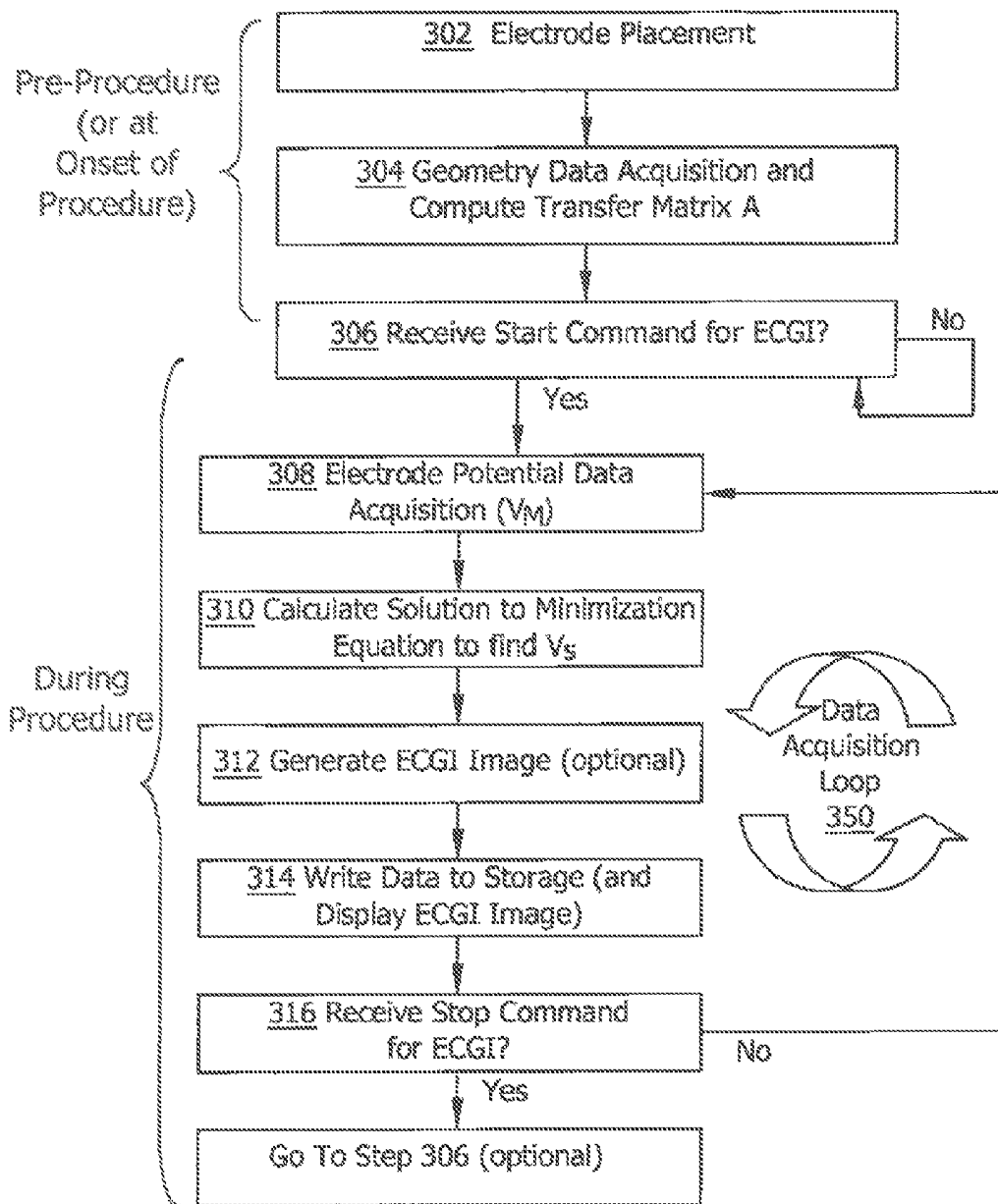



FIG. 4A

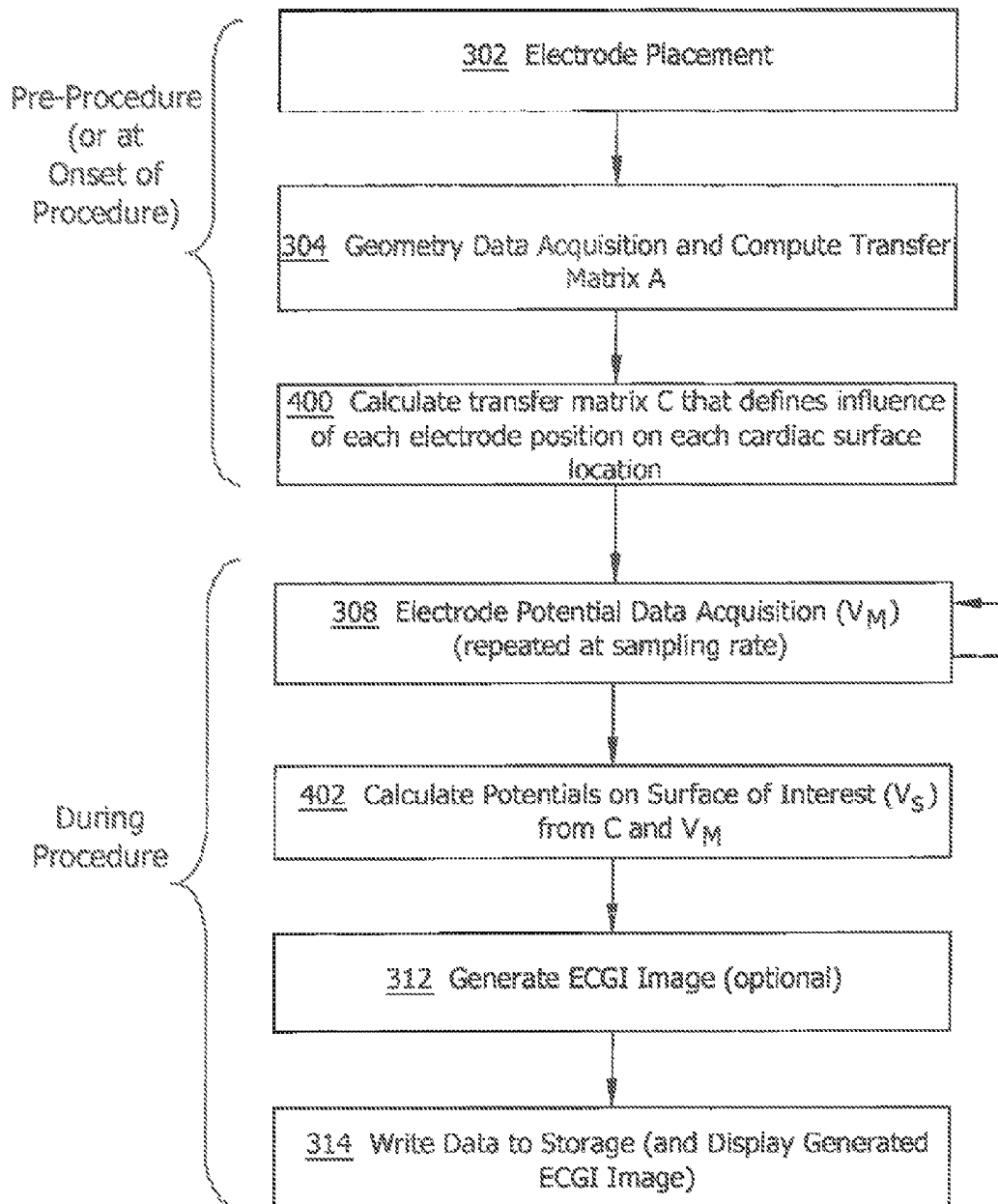

FIG. 4B

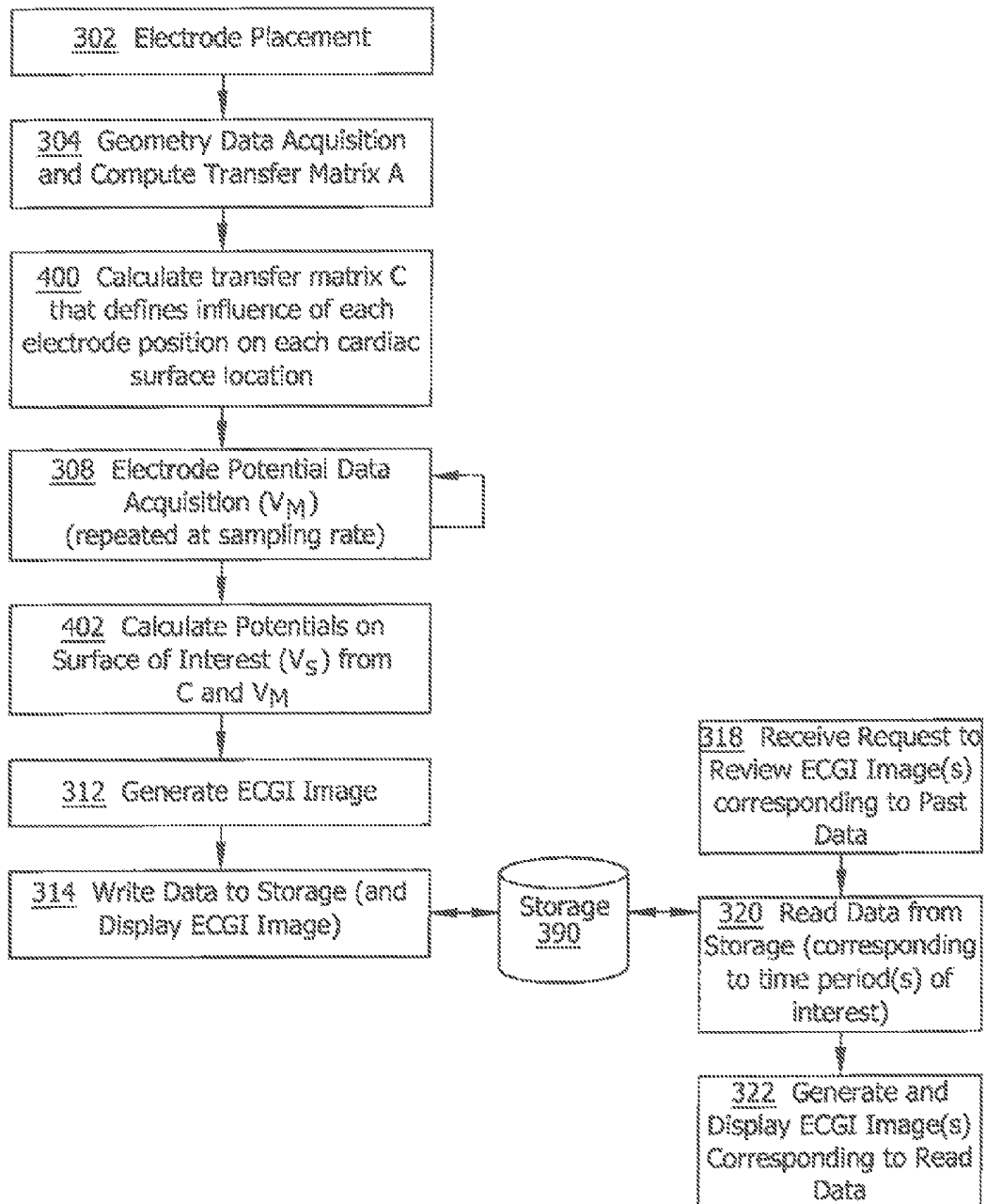

FIG. 4C

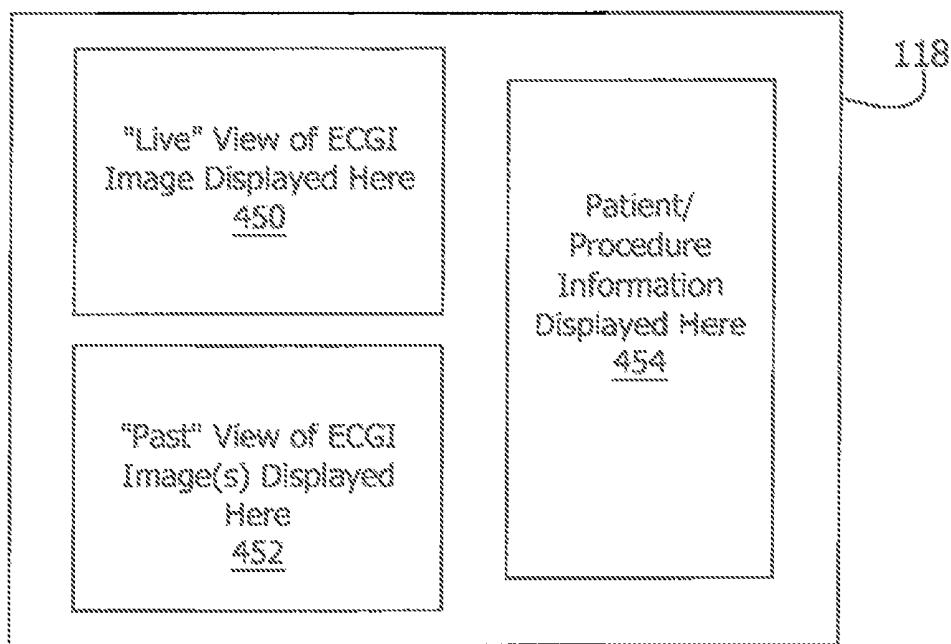

FIG. 5A

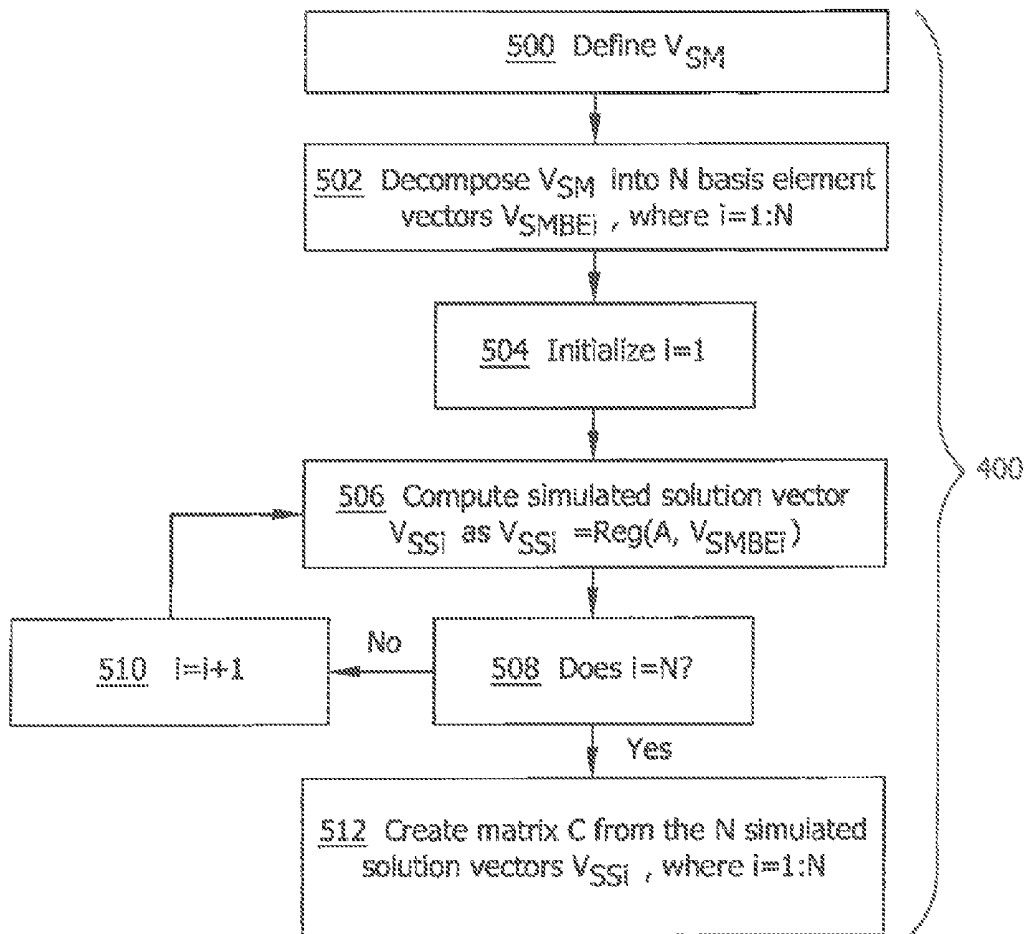

FIG. 5B

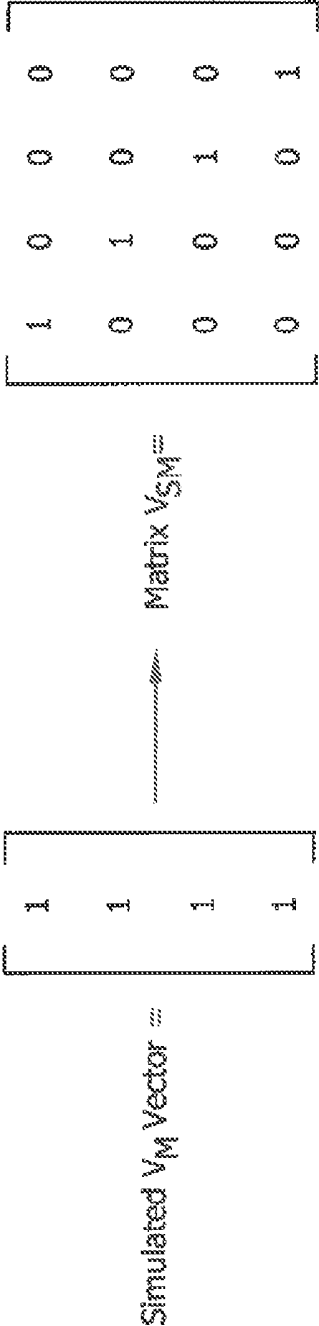
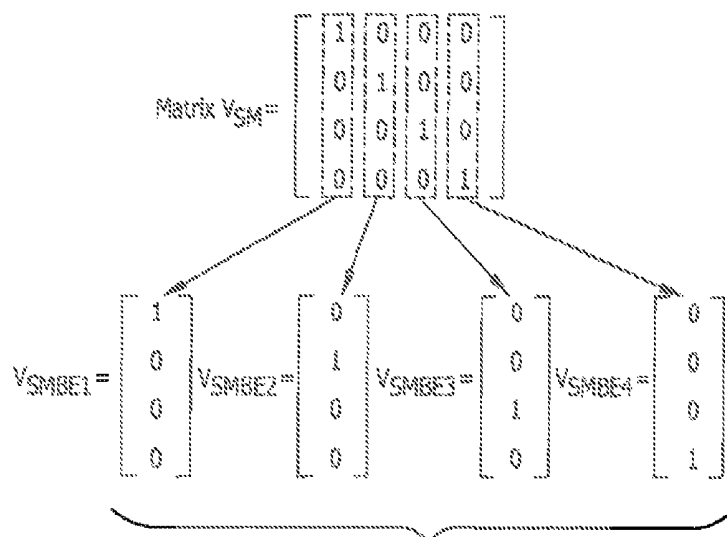

FIG. 5C



The  $N \times N$  matrix  $V_{CM}$  is decomposed into  $N$  basis element vectors  $V_{SMBE1}$  -  $V_{SMBE_n}$  as shown ( $N$  is 4 in this example).

It thus follows that:

$$V_M = \begin{bmatrix} V_M(1) \\ V_M(2) \\ V_M(3) \\ V_M(4) \end{bmatrix} = V_M(1) * V_{SMBE1} + V_M(2) * V_{SMBE2} + V_M(3) * V_{SMBE3} + V_M(4) * V_{SMBE4} = V_{CM} * V_M$$

FIG. 5D

Computing  $V_{SSi} = \text{Reg}(A, V_{SMBEI})$  for  $i=1$  through  $N$  will yield  $N$  simulated solution vectors  $V_{SSi}$  (in this example,  $N$  is 4 and  $P$  is 6):

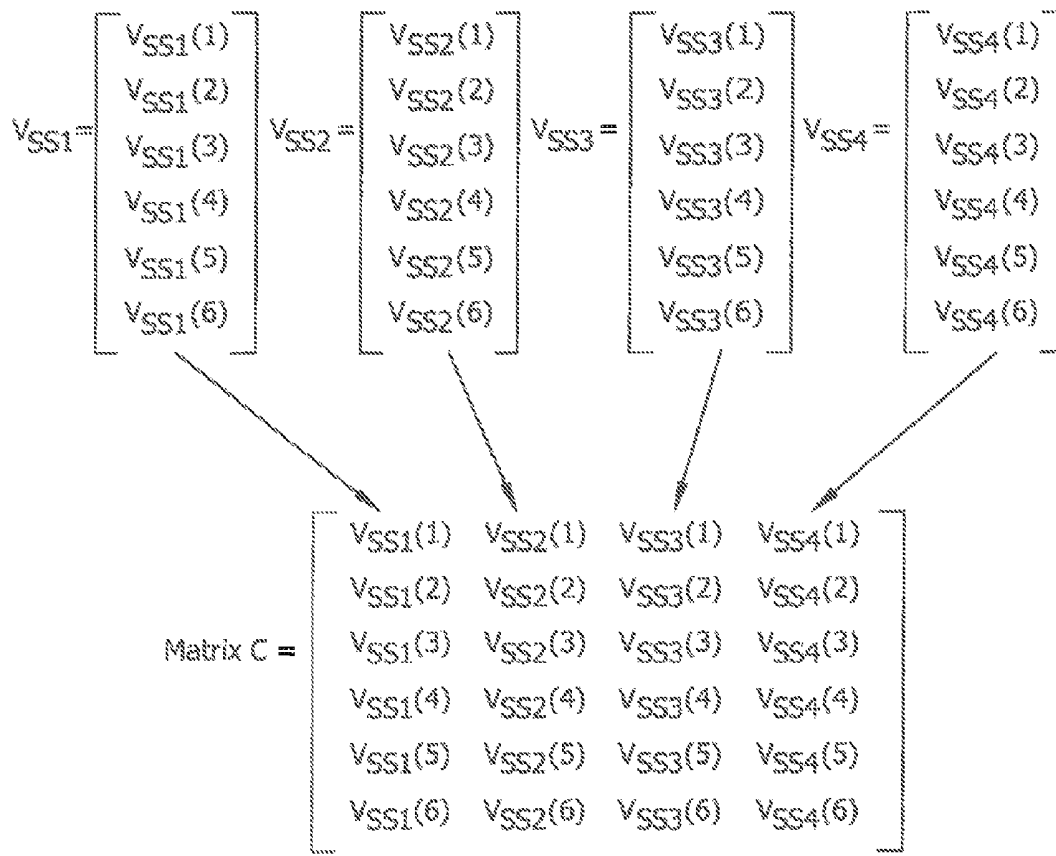

The simulated solution vectors  $V_{SSi}$  are recomposed to form  $P \times N$  matrix C

The estimates of the cardiac surface potentials can then be computed as:

$$V_S = C * V_M$$

FIG. 6A

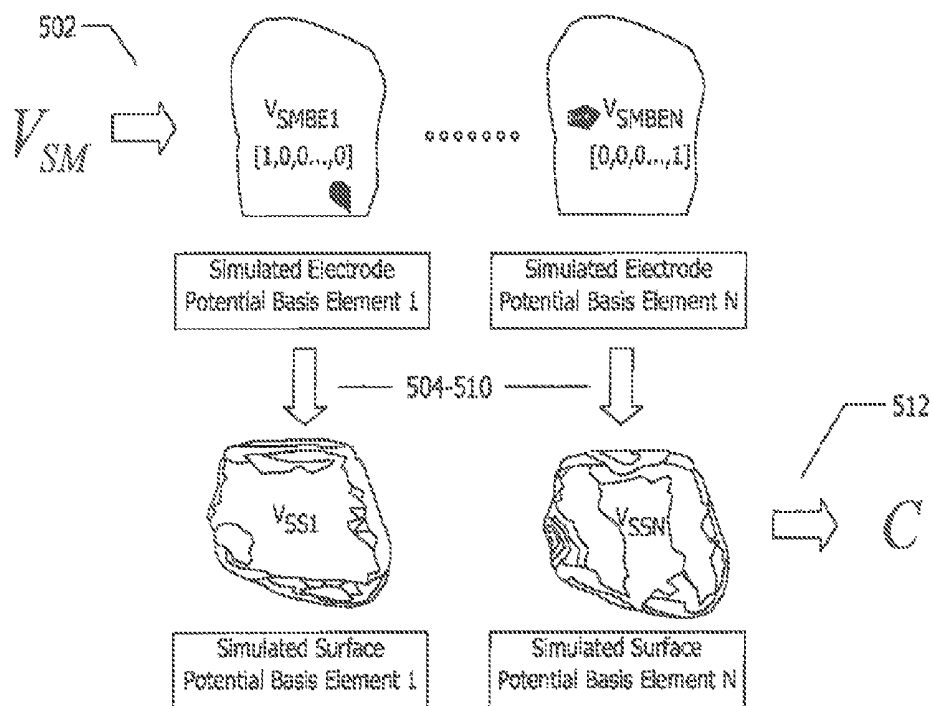
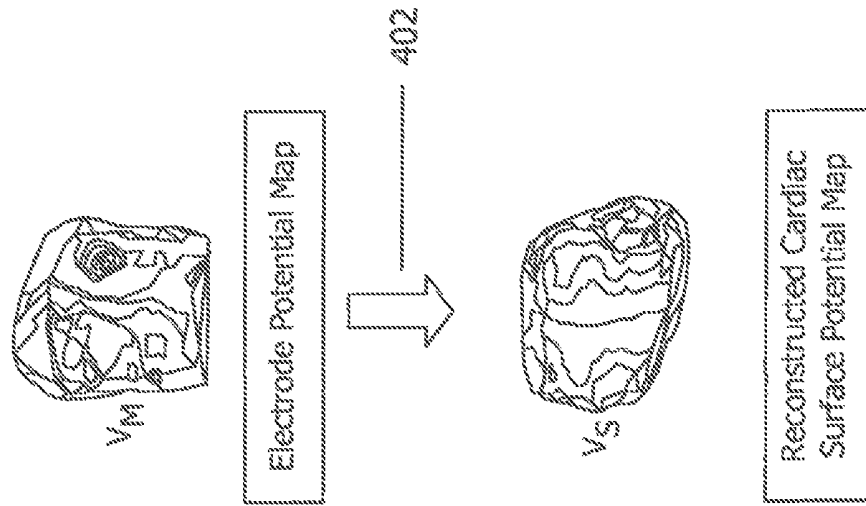
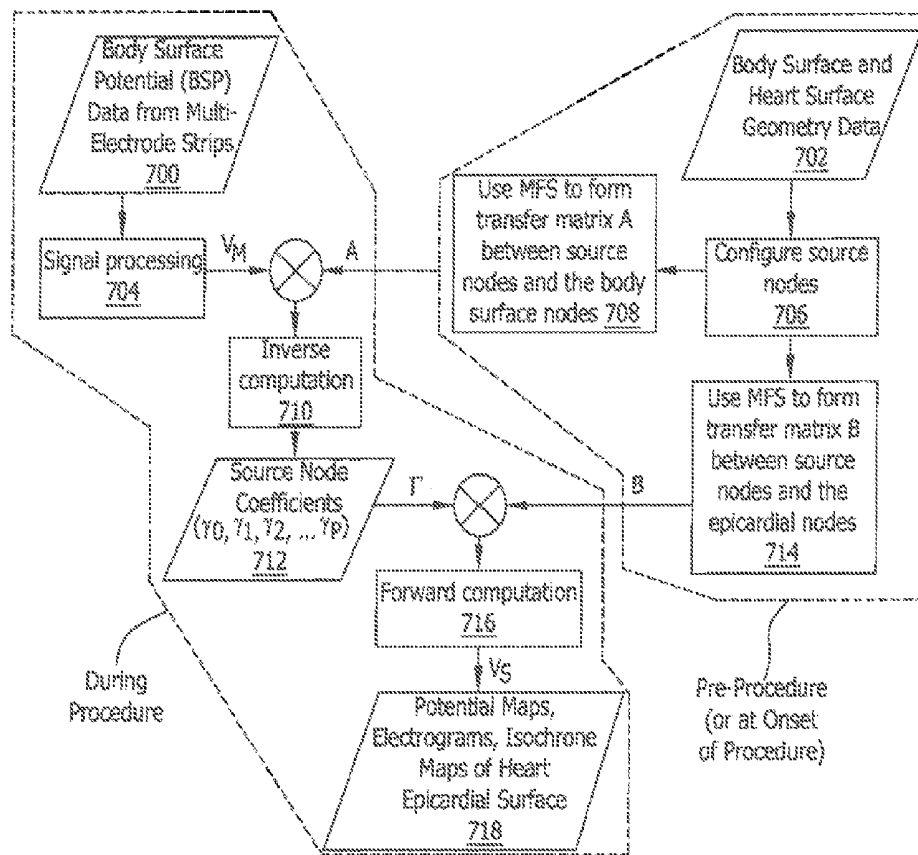

FIG. 6B



$$V_S = C * V_M$$

FIG. 7



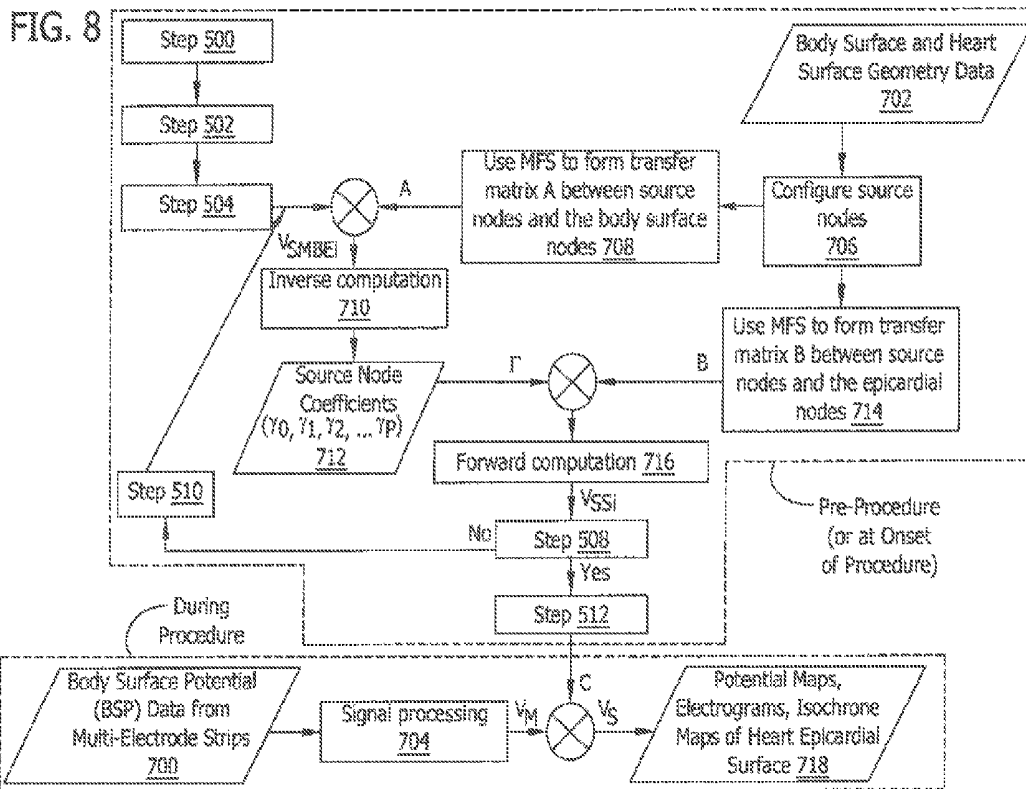

FIG. 9

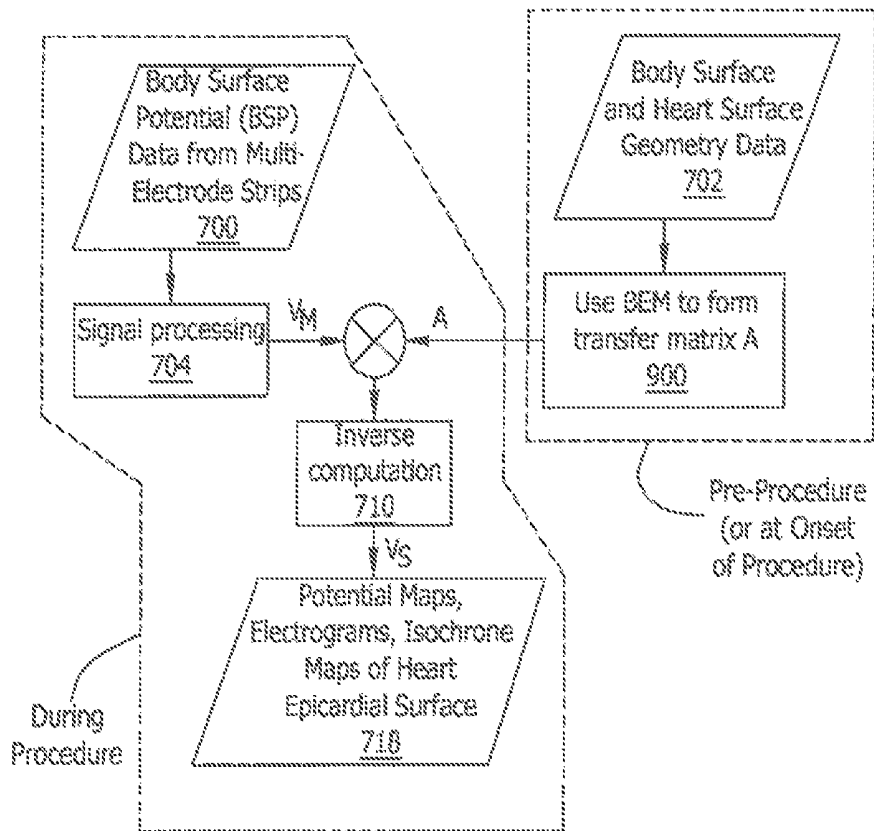

FIG. 10

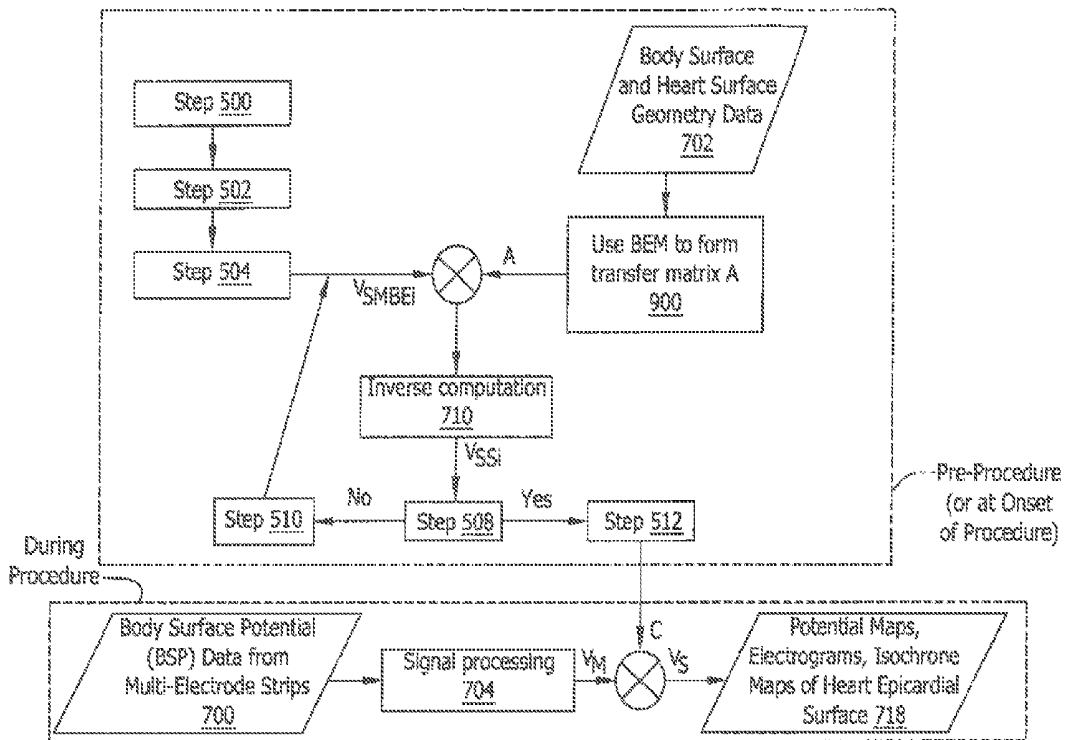

FIG. 11A

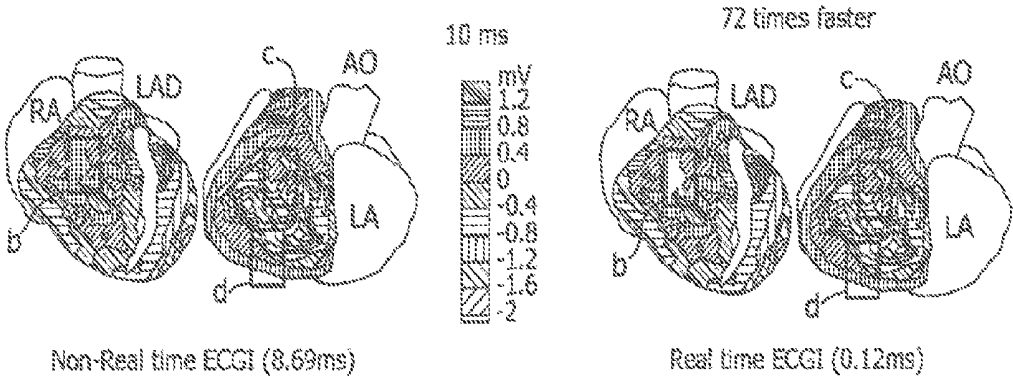

FIG. 11B

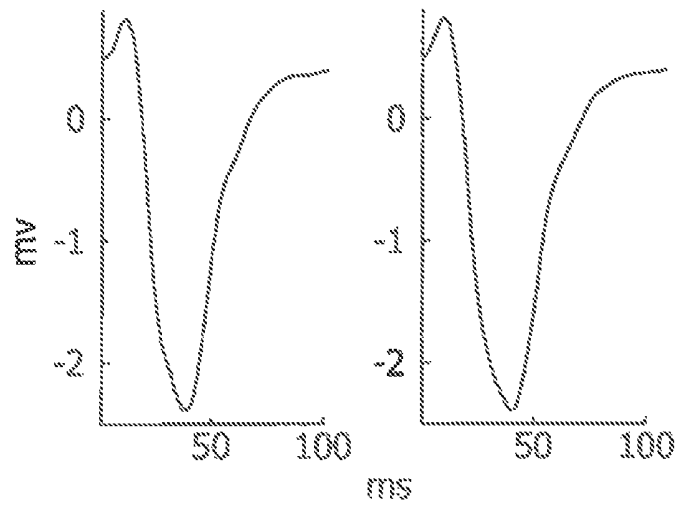

FIG. 11C

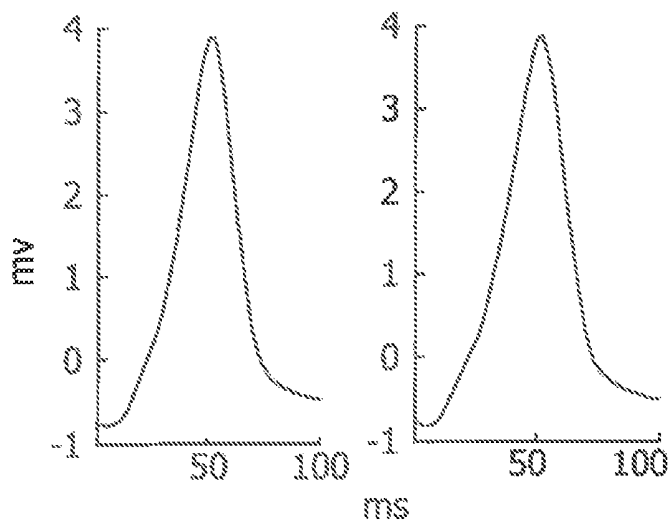
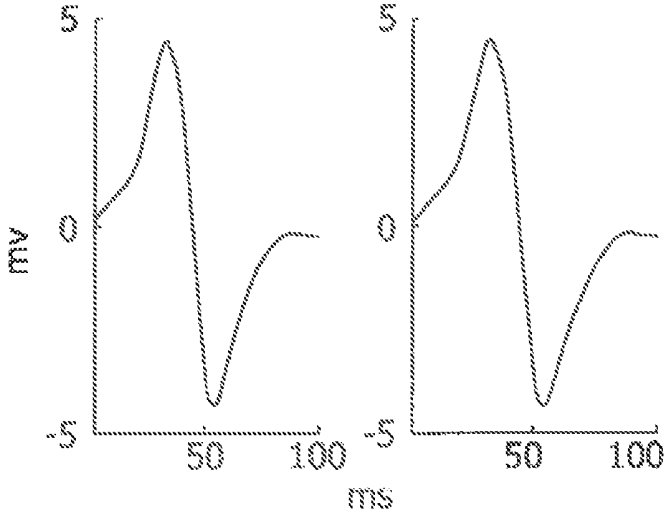

FIG. 11D



**1**  
**SYSTEMS AND METHODS FOR ON-SITE  
 AND REAL-TIME  
 ELECTROCARDIOGRAPHIC IMAGING  
 (ECGI)**

CROSS-REFERENCE TO RELATED  
 APPLICATION

This application is a continuation of U.S. patent application Ser. No. 13/058,520 filed Apr. 15, 2011 and entitled "SYSTEMS AND METHODS FOR ON-SITE AND REAL-TIME ELECTROCARDIOGRAPHIC IMAGING (ECGI)", which is a U.S. National Stage Application filed under 35 U.S.C. §371 of PCT/US2009/053262, having a filing date of Aug. 10, 2009, which claims the benefit of U.S. Provisional Patent Application No. 61/087,875, filed on Aug. 11, 2008, and entitled "SYSTEMS AND METHODS FOR ON-SITE AND REAL-TIME ELECTROCARDIOGRAPHIC IMAGING (ECGI)." The entire contents of each of the above-identified patent applications are incorporated herein by reference.

STATEMENT REGARDING FEDERALLY  
 SPONSORED RESEARCH OR DEVELOPMENT

This invention was made with government support under NIH-NHLBI Grant R37-HL-33343 awarded by the National Institutes of Health (NIH). The government may have certain rights in the invention.

FIELD OF THE INVENTION

This disclosure relates to improved techniques for estimating electrical conditions such as electrical potentials on a surface of interest, particularly in connection with electrocardiographic imaging (ECGI). For example, embodiments of the present disclosure relate to ECGI techniques that reduce the processing time required to compute estimations of cardiac electrical potentials after acquisition of body surface potentials.

BACKGROUND

Previous works by the inventors herein in the field of ECGI are represented by U.S. Pat. No. 6,772,004, entitled "System and Method for Non-Invasive Electrocardiographic Imaging", U.S. Pat. No. 7,016,719, entitled "System and Methods for Noninvasive Electrocardiographic Imaging (ECG) Using Generalized Minimum Residual (GMRES)", U.S. Pat. No. 6,975,900, entitled "Systems and Methods for Determining a Surface Geometry", U.S. Pat. No. 6,839,588, entitled "Electrophysiological Cardiac Mapping System Based on a Non-Contact Non-Expandable Miniature Multi-Electrode Catheter and Method Therefor", U.S. Patent Application Publication 2005/0197587, entitled "Determining a Surface Geometry of an Object", and PCT publication WO 2007/013994, entitled "System and Method for Non-invasive Electrocardiographic Image (ECGI)", the entire disclosures of all of which are incorporated herein by reference.

These works disclose the computation of cardiac surface potentials, electrograms, and isochrones from measured electrode potentials using various techniques. The techniques described herein can be used in conjunction with various combinations of techniques described in the above-referenced works, as will be apparent to those of ordinary skill in the art.

**2**  
 SUMMARY

Embodiments described herein facilitate improving the speed of cardiac surface electrical potential estimations such that those estimations (and, optionally, images derived therefrom) can be made available "on-site" during a medical procedure. When ECGI is said to be practiced "on-site", this means that the estimations of cardiac surface electrical potentials are produced contemporaneously with a medical procedure during which the electrode data for those images is measured. For example, with a medical procedure that is performed in a cardiac electrophysiology (EP) laboratory, such as catheter ablation of the arrhythmia substrate, on-site ECGI allows for heart electrical potentials to be estimated on-site in the EP lab while the catheter ablation is ongoing. With such on-site feedback, ECGI can be used to guide the procedure and evaluate its results. The "on-site" description does not necessarily require that an ECGI image or electrical potential estimation be generated and displayed in the same room in which the medical procedure is occurring, although this is facilitated.

BRIEF DESCRIPTION OF THE DRAWINGS

FIG. 1 illustrates a block diagram overview of an exemplary system for non-invasive ECGI;  
 FIGS. 2A and 2B depict exemplary geometry determining devices;  
 FIGS. 3A-3B illustrate a flowchart of an exemplary embodiment for practicing on-site ECGI;  
 FIGS. 4A-4B illustrate a flowchart of an exemplary embodiment for practicing real-time ECGI;  
 FIG. 4C depicts an exemplary monitor that can display ECGI images in accordance with the embodiment of FIG. 4B;  
 FIGS. 5A-5D depicts an exemplary process flow for computing transfer matrix C in accordance with the embodiments of FIGS. 4A and 4B;  
 FIGS. 6A and 6B provide graphical illustrations corresponding to the computation of transfer matrix C and the computation of estimated surface potentials based on C and measured potentials;  
 FIG. 7 depicts an exemplary process flow for an on-site embodiment of meshless ECGI;  
 FIG. 8 depicts an exemplary process flow for a real-time embodiment of meshless ECGI;  
 FIG. 9 depicts an exemplary process flow for an on-site embodiment of meshed ECGI;  
 FIG. 10 depicts an exemplary process flow for a real-time embodiment of meshed ECGI; and  
 FIGS. 11A-11D depict a comparison of results that can be produced using "real-time" ECGI versus "offline" ECGI.

DETAILED DESCRIPTION

Techniques are described herein to facilitate improving the latency between data acquisition and estimating the electrical potentials on a surface of interest (as well as image generation corresponding to such estimated electrical potentials). The term "surface of interest" as used herein refers to any surface to which the inventive techniques described herein can be applied. In exemplary embodiments, the surface of interest is a cardiac surface for ECGI. In two exemplary embodiments, the surface of interest is the epicardial cardiac surface and endocardial cardiac surface, respectively. However, it should be noted that the techniques

described herein may be adapted to work with other surfaces, and are not limited to cardiac surfaces.

Embodiments described herein facilitate production of ECGI data and images such that ECGI data and images can be made available within a few minutes (or considerably less) of acquiring electrode potential data. This means that ECGI images produced from electrode potential data measured during a medical procedure can be made available on-site during that medical procedure. This allows ECGI images to be used interactively by medical personnel during the medical procedure. Such ECGI images can be especially useful to medical personnel with respect to guiding a medical procedure, as well as evaluating the results of that medical procedure.

Some embodiments disclose a real-time technique wherein ECGI data and images can be produced during a medical procedure within milliseconds after acquiring electrode potential data. Each frame of ECGI data can be computed from a frame of measured electrode potentials in less than 1 millisecond. In an exemplary embodiment wherein the sampling rate of acquiring frames of measured electrode potentials is 1 kHz, it should be readily understood that such computational speed means that ECGI frames can be generated in real-time. This powerful embodiment essentially facilitates “live” views of the estimated electrical potentials on the surface of interest. In doing so, according to an exemplary embodiment, the inventors have devised a technique for precomputing a transfer matrix which allows for the computation of estimated potentials on the surface of interest from the measured potentials via direct matrix multiplication.

In another exemplary embodiment, the system employs a multi-processing computer architecture to further improve the performance of ECGI.

It should be noted that the term “medical procedure” as used herein refers to any medical procedure without limitation. While reference is made herein to specific procedures (e.g. catheter ablation), such references should not be construed as limiting.

FIG. 1 depicts a block diagram overview of an exemplary system 100 for performing non-invasive ECGI. The system 100 comprises a plurality of electrodes 104 (mounted on strips 102, a vest, or in some other array) in communication with a signal acquisition and processing device 106. The electrodes 104 serve to sense a plurality of electrical potentials on a patient’s body surface. The signal acquisition and processing device 106 operates to process this sensed data to a form suitable for digital processing, as is known in the art. The system 100 also comprises a geometry determining device 116 that serves to generate data that is indicative of the geometrical relationship between the electrodes 104 and one or more points of interest within the patient (e.g., the patient’s epicardial cardiac surface)

Processor 114 operates to (1) receive data from both the electrodes 104 (by way of the signal acquisition and processing device 106) and the geometry determining device 116 and (2) reconstruct epicardial cardiac surface potentials from the received data. The reconstructed epicardial potentials can then be used to provide, via the output device 118, images such as electrograms, isochrones (activation maps), epicardial cardiac potential maps, or other data representations derived from the epicardial potentials (e.g., integral maps, recovery maps, activation-recovery interval maps, etc.). An example of a suitable processor 114 is a conventional desktop or laptop computer, such as a 2.4 GHz laptop computer with a gigabyte of RAM. However, as would be understood by those having ordinary skill in the art, any

processor with sufficient memory resources and computational speed would be suitable for use as processor 114. Furthermore, as explained in greater detail herein, by using a multi-processor or multi-core processor as processor 114, significant improvements can be made in computational latency.

Output device 118 may be any device capable of effectively communicating the results of the reconstruction to a user, such as a display monitor and/or printer associated with the processor 114, as would be understood by those having ordinary skill in the art.

It is also worth noting that a variety of known techniques for electronic data communication can be used as the data links between the various elements depicted in FIG. 1, as would be understood by those of ordinary skill in the art. Furthermore, it should be understood that the ECGI techniques described herein can readily be implemented in software and/or hardware for execution by one or more processors to compute epicardial cardiac surface potentials. Moreover, in some instances the processor 114 and geometry determining device may be integrated into the same platform, such as a CT scanner, an MRI scanner, a bi-plane X-ray fluoroscopy apparatus, or an ultrasound echocardiography apparatus that has ECGI processing capabilities built-in.

Electrodes 104 may be arranged on a plurality of strips 102 that can be placed in position on the torso of a patient undergoing ECGI. Alternatively, a vest arrangement as shown in U.S. Pat. Nos. 6,772,004 and 7,016,719 may also be used. As mentioned above, electrodes 104 measure the electrical potentials on the patient’s torso. The electrodes 104 that are used are, in some embodiments, electrodes that are visible in the imaging modality used by the geometry determining device 116. Otherwise, appropriate markers may be placed on the electrodes to render them visible in the images produced by the geometry determining device 116. When practicing ECGI, the total number of electrodes 104, the number of electrodes 104 per strip 102, the number of electrode strips 102, and the placement of the electrode strips 102 on the patient can be variable according to the needs of the ECGI practitioner. In an exemplary embodiment, as much of the patient’s torso (front, back, and sides) as possible is covered by electrodes 104. For example, the total number N of electrodes 104 could range from 120 to 250. However, the value of N may be more or less than a value within this range, as would be understood by a person having ordinary skill in the art. However, the inventors herein believe that the use of too few electrodes will reduce the accuracy of the reconstructed epicardial cardiac surface potentials.

The electrodes can be wet electrodes or dry electrodes, as would be understood by those having ordinary skill in the art. By avoiding the use of gels, short circuiting risks arising from a high concentration of electrodes can be reduced. An example of a suitable type of electrode to obtain body surface potentials is a silver/silver chloride (Ag/AgCl) electrode. However, other types of electrodes such as carbon electrodes can also be used. If CT is used as the imaging modality for the geometry determining device, CT markers may be disposed on the carbon electrodes to render them visible in the CT images.

In an exemplary embodiment, the signal acquisition and processing device 106 is a multi-channel device that operates to receive the sensed electrical potentials from the electrodes 104, process that data, and supply it to processor 114. Practitioners may select a commercially-available system to use as the signal acquisition and processing device

**106.** For example, the Active Two system that is available from BioSemi of WG-Plein 129, 10545C, Amsterdam, Netherlands, which is a 256-channel, DC amplifier, 24 bit resolution biopotential measurement system, may serve as device **106**. The Active Two biopotential measurement system includes an analog-to-digital converter (ADC) that receives electrode data from electrodes **104**, a power source (battery and charger), a USB2 receiver that receives the digital output from the ADC via a fiber optic connection and provides the digital electrode data to acquisition software resident on processor **114** via a USB2 connection. The analog input box that is also part of the Active Two system may be omitted from the practice of the exemplary embodiment.

It should also be noted that custom-designed signal acquisition and processing device **106** can also be used, such as the one described in U.S. Pat. Nos. 6,772,004 and 7,016,719.

The geometry determining device **116** may take a variety of forms, as described in U.S. Pat. Nos. 6,772,004, 6,975,900, and 7,016,719, including x-ray, ultrasound, computed tomography (CT) and magnetic resonance imaging (MRI). For example, as shown in FIG. 2A, the geometry determining device **116** may take the form of a CT scanner or MRI device **200**. The operation and collection of data therefrom will be apparent to those of ordinary skill in the art. In one embodiment, the CT scanner/MRI device **200** is used to generate data, or images, to determine torso geometry and, consequently, body surface electrode positions as well as an epicardial envelope surrounding the heart. As those of skill in the art will appreciate, the epicardial envelope is a suitable estimate of the epicardial cardiac surface itself, which could also be determined. The term "epicardial envelope" as used herein refers to any surface on or outside the epicardial cardiac surface and inside the volume defined by the body surface that at least partially encloses the epicardial cardiac surface. While the term "epicardial envelope" encompasses the actual outer surface of the epicardium, the term "epicardial cardiac surface" as used herein refers specifically to the actual outer surface of the epicardium.

It should also be recognized that locating the epicardial envelope or surface necessarily involves location of the heart. As a further example, as shown in FIG. 2B and described in greater detail in U.S. Pat. Nos. 6,772,004, 6,975,900, and 7,016,719, the geometry determining device **116** may also take the form of a bi-plane x-ray machine **202** and a digitizer **204**, although other imaging modalities (e.g., ultrasound) could also be used.

While FIG. 1 depicts a non-invasive ECGI system, it should also be understood that ECGI can be practiced using invasive techniques. For example, U.S. Pat. No. 6,839,588 describes an invasive ECGI technique wherein an electrode catheter is inserted into a patient and positioned near the patient's endocardium to sense data relating to endocardial electrical potentials. Such a catheter may include a plurality of electrodes. As noted below, embodiments of the present disclosure can employ non-invasive or invasive techniques for measuring the electrical potentials from which the cardiac surface electrical potentials are estimated. On-Site ECGI:

FIG. 3A illustrates an exemplary process flow for practicing on-site ECGI. As noted above, when ECGI is said to be practiced "on-site", this means that the cardiac surface electrical potential estimations are produced contemporaneously with a medical procedure during which the electrode data for those estimations is measured.

At step **302**, the practitioner places electrodes for sensing the patient's electrical potentials. Step **302** is, in some

embodiments, performed prior to the medical procedure or at the outset of the medical procedure. The practitioner can choose to place electrodes invasively or non-invasively. An invasive technique is typically used when the surface of interest is the endocardium, but this is not necessarily the case. As noted above, an exemplary invasive electrode sensing technique suitable for use in connection with exemplary embodiments of the present disclosure is described in U.S. Pat. No. 6,839,588. A non-invasive technique is typically used when the surface of interest is the epicardium, but this is not necessarily the case. As noted above, an exemplary non-invasive electrode sensing technique suitable for use in connection with exemplary embodiments of the present disclosure is described in U.S. Pat. Nos. 6,772,004, 6,975,900, and 7,016,719, PCT Publication WO 2007/013994, and U.S. Patent Application Publication 2005/0197587. It should also be noted that a practitioner may optionally employ both invasive and non-invasive electrode sensing techniques simultaneously.

At step **304**, geometry data is acquired using a geometry determining device such as a CT scanner. In some embodiments, this geometry data defines spatial relationships between the electrodes and various torso features (including cardiac features such as heart position and heart surface locations). In an exemplary embodiment wherein the surface of interest is the endocardium, the geometry data is acquired as described in U.S. Pat. No. 6,839,588. In an exemplary embodiment wherein the surface of interest is the epicardium, the geometry data is acquired as described in U.S. Pat. Nos. 6,772,004, 6,975,900, and 7,016,719, PCT Publication WO 2007/013994, and U.S. Patent Application Publication 2005/0197587. It should also be noted that step **304** may not be necessary if the geometry data is already known.

Step **304** is performed before beginning electrode data acquisition, and optionally prior to the medical procedure or at the outset of the medical procedure. As part of this acquisition, computer algorithms for automated or semi-automated image segmentation and labeling may be used to define the geometrical data (for example a semi-automatic active contour method). However, contouring/segmentation could optionally be performed manually.

Further at step **304**, a transfer matrix A that translates the measured electrode potentials to electric potentials on the surface of interest is computed. Thus, the matrix A is optionally available to the computing system at the start of electrode potential data acquisition (or shortly thereafter). As explained in U.S. Pat. Nos. 6,772,004, 6,975,900, and 7,016,719, PCT Publication WO 2007/013994, and U.S. Patent Application Publication 2005/0197587, the values of transfer matrix A are defined by the geometry data acquired at step **304**. The relationship between the transfer matrix A, the measured electrode potentials  $V_M$  and the surface of interest electric potentials  $V_S$  can be expressed as:

$$V_M = AV_S \quad (1)$$

wherein  $V_M$  is an  $N \times 1$  vector, wherein  $V_S$  is a  $P \times 1$  vector, wherein N represents the number of electrodes used to sense electrical potentials, and wherein P represents the number of locations on the surface of interest for which the electrical potentials are estimated. It should be noted that P need not be the same value as N. It should also be noted that in a non-invasive embodiment wherein the electrode measurements are made from a patient's torso surface,  $V_M$  can be expressed as  $V_T$ . It should further be noted that in embodiments wherein the surface of interest is the epicardial surface or endocardial surface,  $V_S$  can be expressed as  $V_E$ .

At step 306 the system waits to receive a start command from the system operator. When the system receives a start command, flow proceeds to step 308.

At step 308, electrode potential data is measured and recorded in data storage such as computer memory. Step 308 is performed during the medical procedure. In some embodiments, potential data is measured and recorded from all of the electrodes during step 308. This combined electrode potential data, acquired in one execution of step 308, is referred to herein as one "frame" of electrode potential data (represented as the vector  $V_M$  in Equation (1) above).

At step 310, the process computes an estimate of the electrical potentials on the surface of interest ( $V_S$ ). Step 310 may be performed during the medical procedure. As noted above,  $V_S$  represents an estimate of the electric potentials on the surface of interest at a plurality P of discrete locations on the surface of interest. With reference to Equation (1) above, due to the ill-posed nature of A, direct calculation of  $V_S$  cannot be computed as  $A^{-1} * V_M$ .  $V_S$  may therefore be calculated as the vector which minimizes the following equation minimization equation:

$$\min_{V_S} (\|AV_S - V_M\|^2 + t\|LV_S\|^2) \quad (2)$$

In Equation (2), t is a regularization parameter and L is an identity or a differential (first or higher order) operator. In some embodiments, t is found using the CRESO (Composite Residual and Smoothing Operator) method, as described in U.S. Pat. No. 6,772,004. A regularization technique is used to solve equation (2), and the regularization technique may take the form of Tikhonov regularization, as described in U.S. Pat. No. 6,772,004. However, it should be noted that a variety of other regularization techniques may be used, such as GMRes regularization. Examples of such regularization schemes are described in U.S. Pat. Nos. 6,772,004, 6,975,900, and 7,016,719, PCT Publication WO 2007/013994, and U.S. Patent Application Publication 2005/0197587. It should be understood that other regularization techniques can also be applied, in addition to, or in lieu of, the techniques mentioned above. Furthermore, in an exemplary embodiment, the regularization calculations may depend on limiting the value of the spatial derivative of electric potential on the surface of interest to a certain threshold value.

For purposes of concise expression, the solution "z" to Equation (2) above will be expressed as:

$$z = \text{Re } g(x, y) \quad (3)$$

wherein the function  $\text{Reg}(x, y)$  is a shorthand reference for the solving of Equation (2) using input variable "x" as the "A" term in Equation (2) and using input variable "y" as the " $V_M$ " term in Equation (2) to find "z" as the " $V_S$ " term in Equation (2). Thus,  $V_S$  in the on-site embodiment may be computed according to Equation (2) using the shorthand of Equation (3) as:

$$V_S = \text{Re } g(A, V_M) \quad (4)$$

Because the process flow of FIG. 3A operates to compute A prior to measuring electrode potentials at step 308, the embodiment of FIG. 3A is capable of computing  $V_S$  in a sufficiently expedited manner as to make  $V_S$  available to medical personnel during the same procedure in which  $V_M$  was measured.

At step 312, the system can optionally generate an ECGI image, which can be any of the image types discussed above. For example, the ECGI images may take the form of electrograms, isochrones (activation maps), epicardial cardiac potential maps, or other data representations derived from the estimated surface potentials (e.g., integral maps,

recovery maps, activation-recovery interval maps, etc.), as described in U.S. Pat. Nos. 6,772,004, 6,975,900, and 7,016,719, PCT Publication WO 2007/013994, and U.S. Patent Application Publication 2005/0197587. Each ECGI image optionally comprises a visual representation of the solution  $V_S$  calculated at step 310. The system may be configured to generate an ECGI image at each iteration (i.e. for each frame of data), for a fraction of iterations, or in response to user-input as described below. The system may optionally display the generated image until the next image is generated in a subsequent iteration. For example, the images may be displayed on one or more video monitors available to the medical personnel, wherein the monitors can be Liquid Crystal Displays (LCDs), as an example.

It should also be noted that various flow control mechanisms can be applied to alter the flow of FIG. 3A. For example, at step 312, the process flow can be made interactive according to the requests of a practitioner such as a medical professional conducting the medical procedure. For example, such a request may be made during the medical procedure by medical personnel. Thus, in an exemplary embodiment, step 312 may be optional, and a request for ECGI data such as an ECGI image may be received, and the decision to generate an ECGI image for a given iteration may be made in response to the received request. In a non-limiting exemplary embodiment, the system may be configured such that step 310 is performed on-demand as well, such that surface potential estimates are only calculated in response to a request for an ECGI image.

At step 314, the system writes data to data storage (such as a computer memory), from which it can later be retrieved for additional use. In some embodiments, the data written to memory comprises at least  $V_S$ , and, optionally,  $V_M$ ,  $V_S$ , and any generated images. Optionally, this data is stored for later use, for example according to the exemplary embodiment depicted in FIG. 3B. Step 314 may also be performed during the medical procedure. It should be noted that the system may optionally be configured such that a practitioner can toggle data recording on and off independently (i.e. toggle whether step 314 is performed).

It should be noted that steps 308, 310, 312, and 314 may be repeated in a data acquisition loop 350 as illustrated in FIG. 3A. The frequency of looping back to step 308 can be variable according to the preferences of a practitioner. Electrode potential data at step 308 can be acquired from the electrodes at a sampling rate of about 1 kHz, or 1 frame per millisecond (ms). In other words, step 308 can be executed approximately once every millisecond. However, it should be understood that a wide range of frequencies are possible. In an exemplary embodiment, steps 308, 310, 312, and 314 can be executed each time a data measurement is taken from the electrodes. However, it should be noted that some steps could be skipped for some iterations of the data acquisition loop 350. For example, steps 310 and 312 might be performed only in half of the iterations of the data acquisition loop 350. A wide variety of adjustments for the ratio of performance of step 308 relative to steps 310 and 312 can thus be used.

In one embodiment, the data acquisition loop 350 runs continuously during the medical procedure, although this need not be the case. For example, a practitioner might pause the data acquisition loop 350 by issuing a stop command at step 316, and later re-start the data acquisition loop 350 by issuing a start command at step 306.

In some embodiments, steps 302, and 304 are executed only once for a given medical procedure, but it is foreseeable that additional executions may be desirable (particularly in

an invasive version of step 302, which may require a device such as an electrode catheter to be re-positioned multiple times throughout the procedure).

Steps 310, 312, and 314 can be executed outside of data acquisition loop 350, for example in a parallel process, although this need not be the case. It should be noted that the system can be configured to perform steps 310, 312, and 314 in parallel with step 308. In some embodiments, step 310 is performed in real-time with respect to step 308. In one embodiment, both steps 310 and 312 are performed in real-time with respect to step 308.

It should also be noted that steps 308 (at least the data acquisition portion of step 308), 310, 312, 314, 316, and 318 are performed by a processor such as processor 114 of FIG. 1. In an exemplary embodiment, processor 114 can be a single processor having multiple processing cores (e.g., a dual core processor). With such an embodiment, the computational steps of steps 308, 310, 312, and 314 can be distributed across different processing cores to reduce the latency between steps 308 and 310 (as well as step 312 and subsequent operations). For example, steps 308 and 310 can be allocated to different processing cores or steps 308 and 310 can be allocated to one core of the multi-core processor while steps 312 and 314 are allocated to a different core of the multi-core processor. Thus, having acquired the potential data at step 308 and having received a request at step 312 to generate one (or more) ECGI images, the system will be capable of generating the requested images while also continuing to compute estimated surface potentials at step 312 for new data. It should also be noted that rather than using a multi-core processor, multiple processors can be used to the same effect. Moreover, the system may optionally contain multiple computer memories such that the system is capable of writing acquired electrode potential data to one computer memory while simultaneously writing estimated surface potential data to a second memory.

FIG. 3B depicts an exemplary embodiment wherein the system is configured to display ECGI images on demand based on previously recorded  $V_S$  data. Steps 318, 320, and 322 are responsible for generating and displaying images corresponding to the previously recorded data. As can be seen in FIG. 3B, images can be generated from previously recorded data while the system simultaneously continues to execute the data acquisition loop.

At step 318, the system receives a request for an ECGI image corresponding to a particular time period. This request may also define an ECGI image type (e.g., electrogram, isochrone, etc.) and a time period of interest for which the ECGI data is desired. The request can be input into the system in a variety of ways. For example, a doctor could be interested in a particular cardiac cycle, and the doctor would thus request to see an ECGI image sequence corresponding to that particular cardiac cycle.

At step 320, the system reads  $V_S$  data from storage 390 corresponding to the time period(s) of interest.

At step 322, the system generates and displays the appropriate ECGI image(s) corresponding to the retrieved  $V_S$  data. The ECGI image(s) displayed at step 322 are optionally displayed during a medical procedure, and may correspond to data recorded previously during the same medical procedure. However, it is foreseeable that a practitioner may wish to display ECGI images corresponding to a different time period (e.g. a prior medical procedure). In some embodiments, the system is capable of displaying multiple ECGI images simultaneously (e.g. on multiple monitors), and in an exemplary embodiment could display images corresponding to data recorded during the current medical procedure con-

currently with ECGI images corresponding to data recorded during a prior medical procedure. Furthermore, the system may optionally be configured to simultaneously display a "current" view of ECGI data (e.g. images generated at step 312) as well as images corresponding to previously recorded data (e.g. images generated at step 322).

It should be noted that the process flow of FIG. 3B may optionally include step 312 within loop 350 between steps 310 and 314. In this way, the data written to memory at step 314 can also include the ECGI image(s) generated at step 312. Thus, when step 320 operates to retrieve data from memory, step 320 can be configured to retrieve the appropriate ECGI image(s) that were previously generated at step 312. In such a scenario, step 322 need not necessarily include an image generation feature. Further still, it should be noted that the system can be configured to display ECGI images corresponding to pre-recorded data concurrently with "live" ECGI images. In such a scenario, step 322 would operate to display both the currently generated ECGI image from step 312 and a previously-recorded ECGI image from a previous iteration of step 312 or from a retrieval and generation operation at steps 320 and 322.

Further still, for the embodiments of FIGS. 3A and 3B, it should be noted that step 310 may optionally be removed from loop 350 and placed into the process flow following step 320 (or in some other location allowing for on-demand performance of step 310). In such an instance with respect to FIG. 3B, step 314 would operate to write  $V_M$  data to memory 390, and step 320 would operate to retrieve the appropriate frame(s) of VM data from memory which corresponding to the time period(s) of interest. Following this retrieval, step 310 would operate to compute  $V_S$ , and step 322 would operate to generate the appropriate ECGI image(s). In this way, the computation of specific Vs frames can also be performed in an on-demand manner.

Thus, with respect to the exemplary process flows of FIGS. 3A and 3B, by computing A prior to acquiring  $V_M$ , practitioners can expedite the computation of  $V_S$ , thereby allowing ECGI to be practiced on-site during medical procedures.

Real-Time ECGI:

FIGS. 4A and 4B illustrate exemplary process flows for practicing real-time ECGI. As noted above, with real-time ECGI, estimated electrical potentials on the surface of interest (and optionally corresponding ECGI images) can be computed with dramatically reduced latency to thereby allow an essentially "live" view of the surface of interest's electrical potentials.

With real-time ECGI, steps 302, 304, 308, 312, and 314 may operate as previously described. With the process flows of FIGS. 4A and 4B, it should be understood that step 308 is repeated at the sampling rate of the electrode measurement system (e.g., 1 kHz), and that steps 402, 312, and 314 may be performed for each sampled frame of  $V_M$ . Also, as shown in FIG. 4A, the process flow for real-time ECGI includes a step 400 wherein a transfer matrix C is calculated. Step 400 is performed prior to acquiring actual electrode potential measurements (step 308), optionally prior to the medical procedure or at the outset of the medical procedure.

The transfer matrix C defines a relative weight for how each electrode position influences the estimated electrical potentials for each location on the cardiac surface for which an electrical potential is to be estimated. As explained below, once C is known, the computation of  $V_S$  from  $V_M$  is a simple matter of matrix multiplication between C and  $V_M$ , thereby providing dramatic acceleration with respect to how quickly Vs can be computed relative to previous techniques.

FIG. 5A depicts an exemplary process flow for step 400. At step 500, a simulated or “scout” measurement matrix  $V_{SM}$  is defined. To define  $V_{SM}$ , one can assume that a simulated or “scout”  $V_M$  vector exists wherein each element in the simulated  $V_M$  vector is known. In one embodiment, this simulated  $V_M$  assumes a value of “1” for all elements of the simulated  $V_M$ . However, as explained below, this need not be the case. An example of this where N equals 4 is shown in FIG. 5B. The matrix  $V_{SM}$  can then be defined as an N×N matrix wherein the diagonal values for  $V_{SM}$  are equal to the values of the simulated  $V_M$  vector and all other matrix elements are zero. Thus, in the example of FIG. 5B,  $V_{SM}$  is an 4×4 identity matrix.

At step 502, the matrix  $V_{SM}$  is decomposed into a plurality N of basis element vectors  $V_{SMBEi}$ , for all values of i from 1 through N. To achieve this, each  $V_{SMBEi}$  corresponds to column i of  $V_{SM}$ . An example of such decomposition is shown in FIG. 5C, wherein the 4×4 identity matrix  $V_{SM}$  is decomposed into 4 basis element vectors  $V_{SMBE1}$  through  $V_{SMBE4}$ .

At step 504, an iteration index i is initialized to 1. Then at step 506, the system computes a simulated solution vector  $V_{ssi}$  as follows:

$$V_{ssi} = \text{Reg}(A, V_{SMBEi}) \quad (5)$$

The regularization technique used to solve equation (5) is a linear regularization technique (such as Tikhonov regularization or a linear approximation of a nonlinear regularization technique (such as a linear approximation of the GMRes regularization technique)). Examples of additional linear regularization techniques that may optionally be used include Singular Value Decomposition (SVD) and Truncated Singular Value Decomposition (TSVD). As per steps 508 and 510, step 506 operates to compute  $V_{ssi}$  according to equation (5) for all N values of i.

Each value of  $V_{ssi}$  is a P element vector and represents the estimated cardiac surface potentials at all P cardiac surface locations if the ith electrode measured a “1” while all other electrodes measured a zero (or while all other electrodes are effectively “turned off”).

Once all N values of  $V_{ssi}$  have been calculated, step 512 operates to create the matrix C. To do so, each vector  $V_{ssi}$  serves as the ith column in C. An example of creating matrix C in this manner is shown in FIG. 5D. Thus, as can be seen, C is a P×N matrix, and C represents how each electrode position relatively influences the estimated electrical potentials at each cardiac surface location for which the electrical potentials are to be estimated.

Once C has been calculated, the system can begin acquiring electrode measurements to define  $V_M$  (step 308). Once  $V_M$  is known,  $V_S$  can readily be calculated at step 402 according to matrix multiplication as:

$$V_S = CV_M \quad (6)$$

The computation according to Equation (6) is extremely fast because it is merely a matrix multiplication, which computers are well-suited to solve. Furthermore, due to the speed at which  $V_S$  can be computed according to Equation (6), the process flow of FIG. 4A allows for “real-time” computations of  $V_S$  from  $V_M$  because the speed at which  $V_S$  is computed according to Equation (6) is expected to greatly exceed the sampling rate used to measure  $V_M$  (e.g., a  $V_M$  sampling rate of around 1 kHz, or one frame of  $V_M$  every millisecond). An illustration of this speed is described in connection with FIGS. 11A-11D.

The computation of  $V_S$  from  $V_M$  and C can be performed as a result of the following properties of the ECGI system. First, as per Equation (4):

$$V_S = \text{Reg}(A, V_M) \quad (4)$$

Furthermore, as shown in FIG. 5C, when  $V_{SM}$  is an N×N identity matrix:

$$V_M = \sum_{i=1}^N (V_M(i) * V_{SMBEi}) \quad (7)$$

From the inherent properties of identity matrices, it also follows that:

$$V_M = V_{SM} * V_M \quad (8)$$

Substituting the expression for  $V_M$  in Equation (7) into Equation (4) thus yields

$$V_S = \text{Reg}\left(A, \left(\sum_{i=1}^N (V_M(i) * V_{SMBEi})\right)\right) \quad (9)$$

Given the linear properties of the linear regularization technique used for  $\text{Reg}()$  equation (9) can also be expressed as:

$$V_S = \sum_{i=1}^N (V_M(i) * \text{Reg}(A, V_{SMBEi})) \quad (10)$$

As noted above in Equation (5),  $V_{ssi}$  can be expressed as:

$$V_{ssi} = \text{Reg}(A, V_{SMBEi}) \quad (5)$$

Substituting the expression for  $V_{ssi}$  in Equation (5) into Equation (10) thus

$$V_S = \sum_{i=1}^N (V_M(i) * V_{ssi}) \quad (11)$$

Given that C is defined such that each column i of C is formed from vector  $V_{ssi}$  (see FIG. 5D), and using the same algebraic properties that allow Equation (8) to be derived from Equation (7), this means that Equation (11) can also be expressed as Equation (6):

$$V_S = CV_M \quad (6)$$

FIG. 6A illustrates a graphical depiction of how the process flow of FIG. 5A can progress from step 502 to step 512. FIG. 6A depicts examples of how the 1st and Nth electrodes, when simulating a measurement of “1” while all other electrodes simulate a measurement of zero, would influence the estimation of cardiac surface electrical potentials at all P cardiac surface locations. FIG. 6B provides a graphical illustration of how the process flow of FIG. 4A progresses from step 308 to step 402 according to Equation (6).

FIG. 4B illustrates a process flow that largely corresponds to the process flow of FIG. 3B but for a “real-time” embodiment of ECGI. As such, steps 302, 304, 400, 308, 402, 314, 318, 320, and 322 operate as previously described. Through the process flow of FIG. 4B, a practitioner may not

only generate a “live” view of the ECGI data computed at step 402, but can also generate a “past” view of ECGI data computed during a previous iteration of step 402. Such a simultaneous display of a “live” view and a “past” view corresponding to a time frame of interest may provide certain insights to a practitioner about a patient’s heart condition. FIG. 4C depicts an exemplary output device 118 (such as a display monitor) wherein a section 450 of the monitor is used to display a “live” view of ECGI data and where another section 452 of the monitor is used to display the desired “past” view of ECGI data. Yet another section 454 may optionally be set aside to display miscellaneous information such as a patient or procedure data.

FIGS. 11A-11D depicts exemplary results for practicing “real-time” ECGI such as can be produced via the process flow of FIG. 4A. In the example of FIGS. 11A-11D, 242 body surface electrodes were used to measure  $V_M$ , and  $V_S$  was estimated for 502 epicardial sites. Thus, in this example, N was 242 and P was 502. Such values for N and P can be characterized as typical for clinical applications of ECGI. FIGS. 11A-11D depict a comparison of using (1) “non-real-time” ECGI techniques such as that described in connection with the on-site embodiments of FIGS. 3A and 3B or the “off-site” techniques described in the above-referenced and incorporated patents and patent applications, and (2) the “real-time” techniques described in connection with FIG. 4A. The same data set was used for the electrode data for both the “non-real-time” and “real-time” ECGI techniques. Also, BEM meshing was used to define the geometry data for transfer matrix A with respect to both the “non-real-time” and “real-time” ECGI techniques. Further still, in this particular example, the “non-real-time” ECGI technique used to generate the estimated epicardial potentials was the technique described in connection with the above-referenced and incorporated U.S. Pat. No. 6,772,004.

The reconstructed map of epicardial electrical potential estimates shown on the left of FIG. 11A depicts the epicardial electrical potential estimates estimated using an “non-real-time” ECGI technique. The reconstructed map of epicardial electrical potential estimates shown on the right of FIG. 11A depicts the epicardial electrical potential estimates estimated using the “real-time” ECGI technique described in connection with FIG. 4A. The plots of FIG. 11B depict electrograms reconstructed at location “b” on the epicardium (see the maps) for both the “non-real-time” and “real-time” ECGI techniques. The plots of FIG. 11C depict electrograms reconstructed at location “c” on the epicardium (see the maps) for both the “non-real-time” and “real-time” ECGI techniques. The plots of FIG. 11D depict electrograms reconstructed at location “d” on the epicardium (see the maps) for both the “non-real-time” and “real-time” ECGI techniques. As can be seen, from the maps of FIG. 11A and the plots of FIGS. 11B, 11C, and 11D, the results generated from non-real-time and real-time ECGI are identical. However, as noted in FIG. 11A, the “real-time” ECGI technique produced the  $V_S$  data approximately 72 times faster than the “non-real-time” ECGI technique (0.12 ms versus 8.69 ms). These measures represent how long it took to perform step 310 for non-real-time ECGI and step 402 for the real-time ECGI. It should be understood that step 310 will be the same for both the “on-site” ECGI embodiment described herein and the offline techniques such as those described in the above-referenced and incorporated U.S. Pat. No. 6,772,004. Given the dramatic improvement in computing  $V_S$  from  $V_M$  for the “real-time” technique according to step 402 relative to step 310, the inventors believe that the “real-time” ECGI technique described herein represents a pioneering break-

through toward the goal of deploying ECGI as a valuable guiding or interventional tool during medical procedures such as catheter ablation of arrhythmias, cardiac resynchronization therapy for heart failures, etc.

It should be noted that, while an exemplary embodiment of the “real-time” ECGI uses a simulated VM where all “1”s are used as the simulated measurements (thus resulting in  $V_{SM}$  being an identity matrix), a practitioner could optionally use any arbitrary number for the simulated  $V_M$  values. For example, it could be assumed that each electrode will measure a value of 3.623, in which case  $V_{SM}$  would be an  $N \times N$  matrix with a value of 3.623 for all diagonal elements and a value of zero for all non-diagonal elements. In such an exemplary embodiment, Equation (6) would simply be modified to:  $V_S = C * (1/3.623) V_M$ . Further still, it should be understood that the different simulated values on the diagonal of VSM can have different values relative to each other so long as those values are known in advance to allow that they later be scaled out during the computation of  $V_S$ .

It should also be noted that the process flows of FIGS. 4A and 4B may optionally employ start and stop steps 306 and 316 as described in connection with the process flows of FIGS. 3A and 3B.

With respect to the embodiments described herein, the inventors note that the resultant ECGI images can be stored in computer memory, and that a practitioner may step through the generated images in “slow motion” or pause on a single image. Thus, the exemplary embodiments of ECGI disclosed herein allow medical personnel to view a particular time period of interest with a very high degree of image resolution and clarity.

The inventors also note that the “on-site” and “real-time” techniques described herein may be applied with effectiveness to both meshed and meshless ECGI techniques. For purposes of clarity, the inventors will now describe how “on-site” and “real-time” ECGI can be practiced with respect to a meshless ECGI technique such as that described in PCT Publication WO 2007/013994.

Exemplary Meshless On-Site ECGI Embodiment:

FIG. 7 depicts an example where the process flow of FIGS. 3A and 3B can be implemented in a meshless ECGI environment. FIG. 7 depicts a process flow for meshless ECGI, as described in connection with PCT Publication WO 2007/013994. To perform such meshless ECGI in an on-site manner, steps 702, 706, 708, and 714 are performed before acquiring electrode potential measurements, and optionally prior to the medical procedure or at the outset of the medical procedure, while steps 700, 704, 710, 712, 716, and 718 are performed during the medical procedure. Additional details regarding steps 700, 702, 704, 706, 708, 710, 712, 714, 716, and 718 can be found in PCT Publication WO 2007/013994.

Exemplary Meshless Real-Time ECGI Embodiment:

FIG. 8 depicts an example where the process flow of FIGS. 4A and 4B can be implemented in a meshless ECGI environment. To perform such meshless ECGI in real-time manner. As noted above, additional details regarding steps 700, 702, 704, 706, 708, 710, 712, 714, 716, and 718 can be found in PCT Publication WO 2007/013994.

Exemplary Meshed On-Site ECGI Embodiment:

FIG. 9 depicts an example where the process flow of FIGS. 3A and 3B can be implemented in a meshed ECGI environment. With this embodiment, relative to the process flow of FIG. 7, it can be seen that the transfer matrix B need not be computed (and the corresponding downstream computations based on B as well as step 706 can be eliminated), and step 708 is replaced with a step 900 that uses the Boundary Element Method (BEM) to form transfer matrix

A, as described in connection with the above-referenced and incorporated U.S. Pat. No. 6,772,004.

Exemplary Meshed Real-Time ECGI Embodiment:

FIG. 10 depicts an example where the process flow of FIGS. 4A and 4B can be implemented in a meshed ECGI environment. FIG. 10 largely corresponds to FIG. 8, albeit without the computation of transfer matrix B (and its related downstream operations as well as step 706) and with the inclusion of step 900.

Exemplary Operating Environment:

Methods described herein may be performed by a computer or computing device. A computer or computing device includes one or more processors or processing units, each containing one or more processing cores, system memory, and some form of computer readable media. One or more processors or processing units may be programmed with instructions that cause the processors or processing units to perform one or more of the methods described herein. In some embodiments, a processor is programmed by providing executable instructions on a computer readable medium or media. By way of example and not limitation, computer readable media comprise computer storage media and communication media. Computer storage media include volatile and nonvolatile, removable and non-removable media implemented in any method or technology for storage of information such as computer readable instructions, data structures, program modules, executable components, or other data. Communication media typically embody computer readable instructions, data structures, program modules, or other data in a modulated data signal such as a carrier wave or other transport mechanism and include any information delivery media. Combinations of any of the above are also included within the scope of computer readable media.

Although described in connection with an exemplary computing system environment, embodiments of the invention are operational with numerous other general purpose or special purpose computing system environments or configurations. The computing system environment is not intended to suggest any limitation as to the scope of use or functionality of any aspect of the invention.

Embodiments of the invention may be described in the general context of computer-executable instructions, such as program modules, executed by one or more computers or other devices. The computer-executable instructions may be organized into one or more computer-executable components or modules. Generally, program modules include, but are not limited to, routines, programs, objects, components, and data structures that perform particular tasks or implement particular abstract data types. Aspects of the invention may be implemented with any number and organization of such components or modules. For example, aspects of the invention are not limited to the specific computer-executable instructions or the specific components or modules illustrated in the figures and described herein. Other embodiments of the invention may include different computer-executable instructions or components having more or less functionality than illustrated and described herein.

In an exemplary embodiment, one or more computer-readable media includes computer-executable components. The components include a transfer matrix computation component, a measurement component, and an estimation component. The transfer matrix computation component, when executed by at least one processor, causes the at least one processor to compute a transfer matrix. The measurement component, when executed by the at least one processor, causes the at least one processor to measure a plurality

of electrical potentials. The estimation component, when executed by the at least one processor, causes the at least one processor to compute an estimation of electrical potentials on a surface of interest based at least in part on the measured electrical potentials and the computed transfer matrix. The at least one processor computes the transfer matrix before the at least one processor measures the plurality of electrical potentials.

While the making and use of various embodiments of the invention are discussed in detail above, the embodiments of the invention provide many applicable inventive concepts that may be embodied in a wide variety of specific contexts. The specific embodiments discussed herein are merely illustrative of specific ways to make and use the invention and do not delimit the scope of the invention.

To facilitate the understanding of this invention, a number of terms are defined below. Terms defined herein have meanings as commonly understood by a person of ordinary skill in the areas relevant to the embodiments of the invention. Terms such as "a," "an" and "the" are not intended to refer to only a singular entity, but include the general class of which a specific example may be used for illustration. The terminology herein is used to describe specific embodiments of the invention, but their usage does not delimit the invention, except as outlined in the claims.

The order of execution or performance of the operations in embodiments of the invention illustrated and described herein is not essential, unless otherwise specified. For example, it is contemplated that executing or performing a particular operation before, contemporaneously with, or after another operation is within the scope of aspects of the invention. Embodiments of the invention may include additional or fewer operations than those disclosed herein.

What is claimed is:

1. A non-transitory computer readable medium storing instructions that, when executed by at least one processor, cause the at least one processor to perform a method comprising:
  - computing a transfer matrix representing a relative influence that each respective electrode location for measuring electrical potentials on a patient's body has on an estimation of electrical potentials for locations on a surface of interest of the patient's body different than where the electrode locations are located, prior to the measuring of electrical potentials at the respective electrode locations;
  - receiving electrical potential data corresponding to measurements measured via a plurality of electrodes at the respective electrode locations on the patient's body;
  - computing the estimation of electrical potentials for the locations on the body surface of interest based at least in part on the received electrical potential data and the computed transfer matrix; and
  - outputting, to a display device, an image of the body surface of interest that is indicative of the estimation of electrical potentials for the locations of the surface of interest.
2. The medium of claim 1, wherein the method further comprises:
  - receiving a user input to set a time period; and
  - the electrical potential data being accessed based on the time period such that the generated image represents the estimation of electrical potentials for the time period.
3. The medium of claim 1, wherein the processor computes the estimation of electrical potentials for the locations

on the surface of interest and outputs the image substantially in real-time during a medical procedure to guide the medical procedure.

4. The medium of claim 1, wherein the method further comprises analyzing the estimation of electrical potentials for based on real-time electrical measurements during a medical procedure, such that the generated image provides real-time feedback of a result of the medical procedure.

5. The medium of claim 3, wherein the medical procedure is one of a catheter ablation and cardiac resynchronization therapy (CRT).

6. The medium of claim 1, wherein computing the estimation comprises computing a plurality of transfer matrices prior to measuring the electrical potential on the patient's body, the plurality of transfer matrices comprising a first transfer matrix and a second transfer matrix,

wherein the first transfer matrix represents a geometrical relationship between each of the electrode locations for measuring electrical potentials on the patient's body and a plurality of locations on the surface of interest for which the estimation of electrical potentials are computed,

wherein the second transfer matrix represents a relative influence that each of the electrode locations for measuring electrical potentials on the patient's body has on the estimation of electrical potentials for the locations on the surface of interest, and

wherein computing the estimation comprises multiplying the first transfer matrix and the electrical potential data to generate the estimation of electrical potentials for the locations on the surface of interest.

7. The medium of claim 6, wherein computing the estimation further comprises:

defining a simulated measurement of electrical potential measurements on the patient's body;

computing a plurality of simulated estimations of electrical potentials on the surface of interest based on the simulated measurement and the first transfer matrix; and

generating the second transfer matrix from the computed plurality of simulated estimations.

8. The medium of claim 7, wherein computing the plurality of simulated estimations comprises computing the plurality of simulated estimations of electrical potentials using a linear regularization technique.

9. The medium of claim 1, wherein the surface of interest comprises a cardiac surface.

10. The medium of claim 9, wherein the cardiac surface comprises one of an epicardial surface and an endocardial surface.

11. The medium of claim 1, wherein computing the estimation comprises computing the estimation via a meshless Electrocardiographic Imaging (ECGI) technique.

12. A device, comprising:

a processor;

a non-transitory computer readable medium storing instructions that, when executed by the processor, cause the processor to:

compute a transfer matrix representing a relative influence that each of a plurality of electrode locations for measuring electrical potentials on a patient's body has on an estimation of electrical potentials for locations on a surface of interest of the patient's body different than where the electrode locations are

located, the transfer matrix being computed prior to the measuring of electrical potentials at the respective electrode locations;

receive electrical potential measurements via a plurality of electrodes at respective electrode locations on the patient's body;

compute the estimation of electrical potentials for the locations on the surface of interest based at least in part on the received electrical potential measurements and the computed transfer matrix; and

output, to a display device, an image of the body surface of interest that is indicative of the estimation of electrical potentials for the locations of the surface of interest.

13. The device of claim 12, further comprising a signal acquisition component comprising electrical inputs to receive the electrical potential measurements.

14. The device of claim 13, further comprising a plurality of electrodes connected to the electrical inputs and arranged to measure electrical potential at the plurality of electrode locations on the patient's body.

15. The device of claim 12,

wherein the processor is further configured to compute a plurality of transfer matrices prior to receiving the electrical potential measurements, the plurality of transfer matrices comprising a first transfer matrix and a second transfer matrix,

wherein the first transfer matrix represents a geometrical relationship between each electrode location of the plurality of electrodes where the electrical potential measurements are measured and a plurality of locations on the surface of interest for which the estimation of electrical potentials are computed,

wherein the second transfer matrix represents a relative influence that each of the plurality of electrode locations for the electrical potentials measurements has on the estimation of electrical potentials for the locations on the surface of interest, and

wherein the processor is further configured to compute the estimation by multiplying the first transfer matrix and the electrical potential measurements.

16. The device of claim 15, wherein the processor is further configured to compute the estimation electrical potentials and to output the image substantially in real-time with respect to receiving the electrical potential measurements.

17. The device of claim 15, wherein the processor is further configured to:

define a simulated measurement of the electrical potential measurements;

compute a plurality of simulated estimations of electrical potentials on the surface of interest based on the simulated measurement and the first transfer matrix; and

generate the second transfer matrix from the plurality of simulated estimations.

18. A non-transitory computer readable medium storing machine executable instructions comprising:

a transfer matrix module that, when executed by at least one processor, causes the at least one processor to compute a transfer matrix representing a relative that each respective electrode location for measuring electrical potentials on a patient's body has on an estimation of electrical potentials for locations on a surface of interest of the patient's body different than where the

19

electrode locations are located, prior to the measuring of electrical potentials at the respective electrode locations;

an acquisition module that, when executed by the at least one processor, causes the at least one processor to access measurement data corresponding to a plurality of electrical potentials measured via a plurality of electrodes at respective electrode locations on the patient's body;

an estimation module that, when executed by the at least one processor, causes the at least one processor to compute the estimation of electrical potentials for the body surface of interest based at least in part on the measurement data and the computed transfer matrix; and

a display module that, when executed by the at least one processor, causes the at least one processor to output, to a display device, an image of the body surface of interest that is indicative of the estimation of electrical potentials for the locations on the surface of interest.

19. The medium of claim 18, wherein the processor computes the estimation of electrical potentials and generates the image data substantially in real-time in response to measuring electrical potentials at the respective electrode locations during a medical procedure.

20. The medium of claim 18, wherein the machine executable instructions further comprise a user interface to set a given time period for which the measurement data is accessed in response to a user input, such that the display module generates the image data based on the given time period.

20

21. A device, comprising:

a signal acquisition device comprising electrical inputs to receive electrical potential measurements;

a plurality of electrodes arranged to measure electrical potential at the plurality of electrode locations on a surface of the patient's body, the electrodes connected to the electrical inputs to provide the electrical potential measurements;

a processor;

a non-transitory computer readable medium storing instructions that, when executed by the processor, cause the processor to:

compute a transfer matrix representing a relative influence that each of a plurality of electrode locations for measuring electrical potentials on a patient's body has on an estimation of electrical potentials for locations on a surface of interest, which is different than the electrode locations on the surface of the patient's body, the transfer matrix being computed prior to measuring of electrical potentials at the respective electrode locations;

compute the estimation of electrical potentials for the locations on the surface of interest based at least in part on the received electrical potential measurements and the computed transfer matrix; and

generating image data to display an output on a display device, the output comprising an image of the body surface of interest that is indicative of the estimation of electrical potentials for the locations on the surface of interest.

\* \* \* \* \*

专利名称(译)	用于现场和实时心电图成像 ( ECGI ) 的系统和方法		
公开(公告)号	<a href="#">US9980660</a>	公开(公告)日	2018-05-29
申请号	US14/990469	申请日	2016-01-07
[标]申请(专利权)人(译)	圣路易斯华盛顿大学		
申请(专利权)人(译)	圣路易斯华盛顿大学.路易斯		
当前申请(专利权)人(译)	圣路易斯华盛顿大学.路易斯		
[标]发明人	RUDY YORAM WANG YONG		
发明人	RUDY, YORAM WANG, YONG		
IPC分类号	A61B5/0408 A61B5/04 A61B5/00 A61B6/00 A61B8/08 A61B18/00		
CPC分类号	A61B5/04085 A61B5/04012 A61B5/6805 A61B2018/00839 A61B6/5247 A61B8/0883 A61B8/5261 A61B6/503		
代理机构(译)	TAROLLI , SUNDHEIM , COVELL & TUMMINO LLP		
优先权	PCT/US2009/053262 2009-08-10 WO 61/087875 2008-08-11 US		
其他公开文献	US20160113543A1		
外部链接	<a href="#">Espacenet</a> <a href="#">USPTO</a>		

摘要(译)

非暂时性计算机可读介质存储指令，所述指令在由至少一个处理器执行时使得所述至少一个处理器执行包括计算传输矩阵的方法，所述传递矩阵表示用于测量电势上的电势的每个相应电极位置的相对影响。在测量相应电极位置处的电势之前，患者身体对感兴趣表面上的位置的电位进行估计，并且接收通过患者身体上的相应电极位置处的多个电极测量的电势测量值。该方法还包括至少部分地基于所接收的电势测量值和所计算的传递矩阵来计算感兴趣表面上的位置的电势估计，并生成表示电势估计的图像数据。

