



US 20170042449A1

(19) **United States**

(12) **Patent Application Publication**

Deno et al.

(10) **Pub. No.: US 2017/0042449 A1**

(43) **Pub. Date: Feb. 16, 2017**

(54) **SYSTEM AND METHOD FOR LOCAL ELECTROPHYSIOLOGICAL CHARACTERIZATION OF CARDIAC SUBSTRATE USING MULTI-ELECTRODE CATHETERS**

A61B 18/14 (2006.01)
A61B 5/04 (2006.01)
A61M 25/01 (2006.01)
A61B 5/042 (2006.01)
A61B 5/00 (2006.01)

(71) Applicant: **St. Jude Medical, Cardiology Division, Inc., St. Paul, MN (US)**

(52) **U.S. Cl.**
CPC *A61B 5/068* (2013.01); *A61B 5/0422* (2013.01); *A61B 5/044* (2013.01); *A61B 5/062* (2013.01); *A61B 5/6858* (2013.01); *A61B 5/04012* (2013.01); *A61M 25/0127* (2013.01); *A61B 18/1492* (2013.01); *A61B 2018/00577* (2013.01)

(72) Inventors: **D. Curtis Deno, Andover, MN (US); Ram K. Balachandran, Maple Grove, MN (US)**

(21) Appl. No.: **15/118,522**

(57) **ABSTRACT**

(22) PCT Filed: **Feb. 25, 2015**

A system for determining electrophysiological data comprising an electronic control unit configured to acquire electrophysiology signals from a plurality of electrodes (130) of one or more catheters, select at least one clique of electrodes from the plurality of electrodes (136) to determine a plurality of local E field data points, determine the location and orientation of the plurality of electrodes, process the electrophysiology signals from the at least one clique from a full set of bipole subcliques to derive the local E field data points associated with the at least one clique of electrodes, derive at least one orientation independent signal from the at least one clique of electrodes (138) from the information content corresponding to weighted parts of electrogram signals, and display or output catheter orientation independent electrophysiologic information to a user or process.

(86) PCT No.: **PCT/US15/17576**

§ 371 (c)(1),
(2) Date: **Aug. 12, 2016**

Related U.S. Application Data

(60) Provisional application No. 61/944,426, filed on Feb. 25, 2014.

Publication Classification

(51) **Int. Cl.**
A61B 5/06 (2006.01)
A61B 5/044 (2006.01)

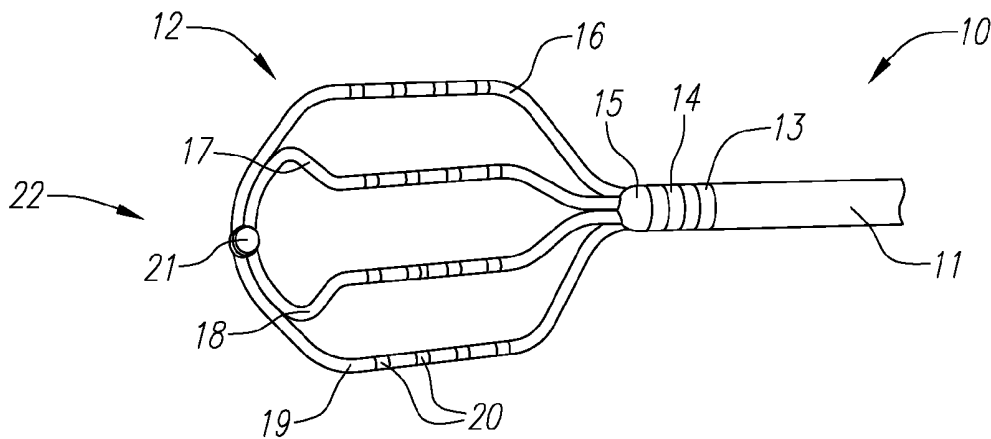

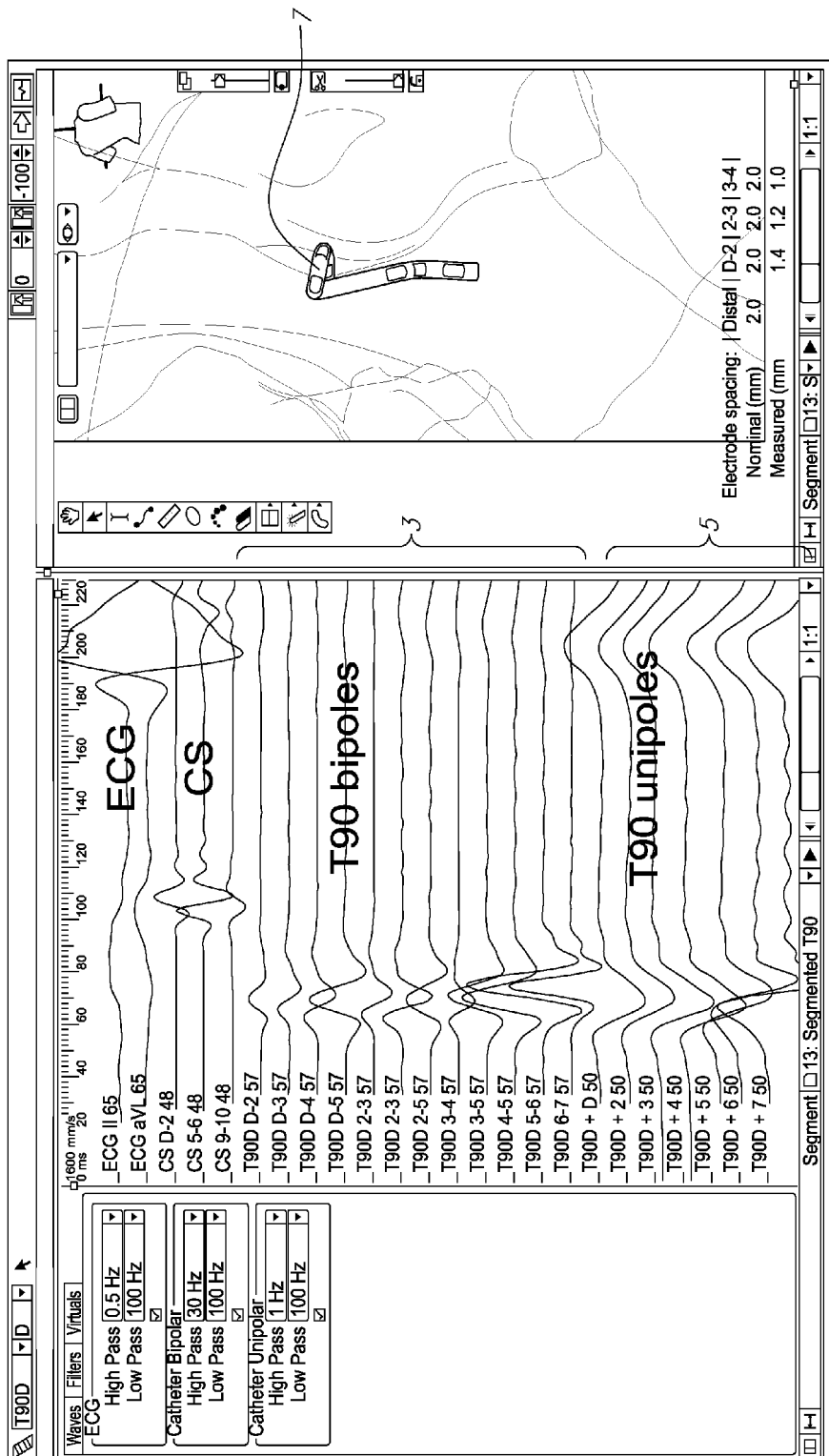
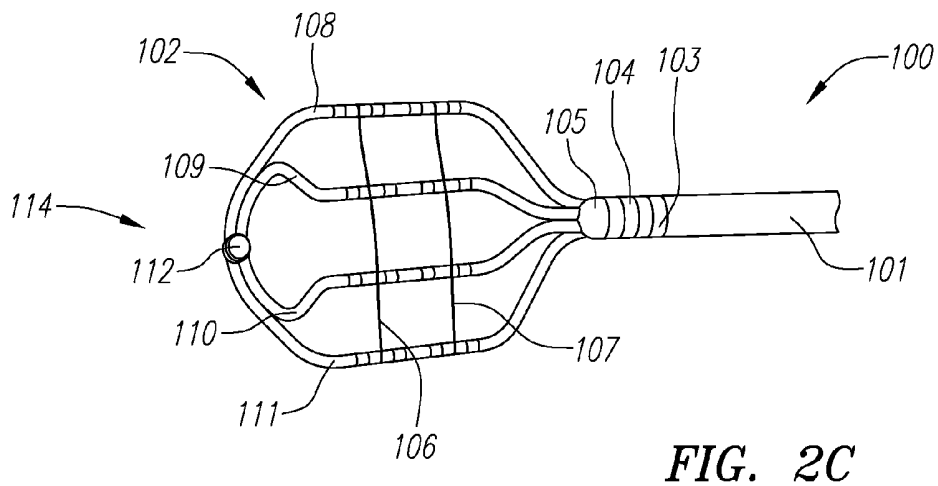
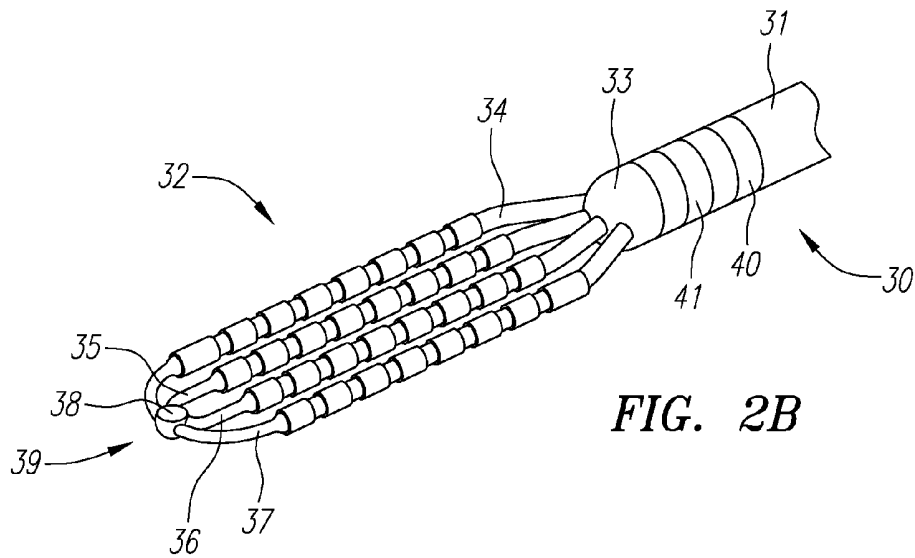
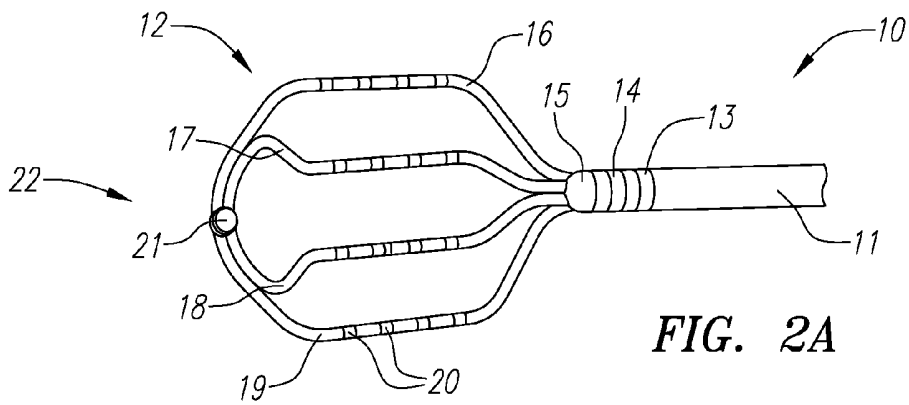

FIG. 1



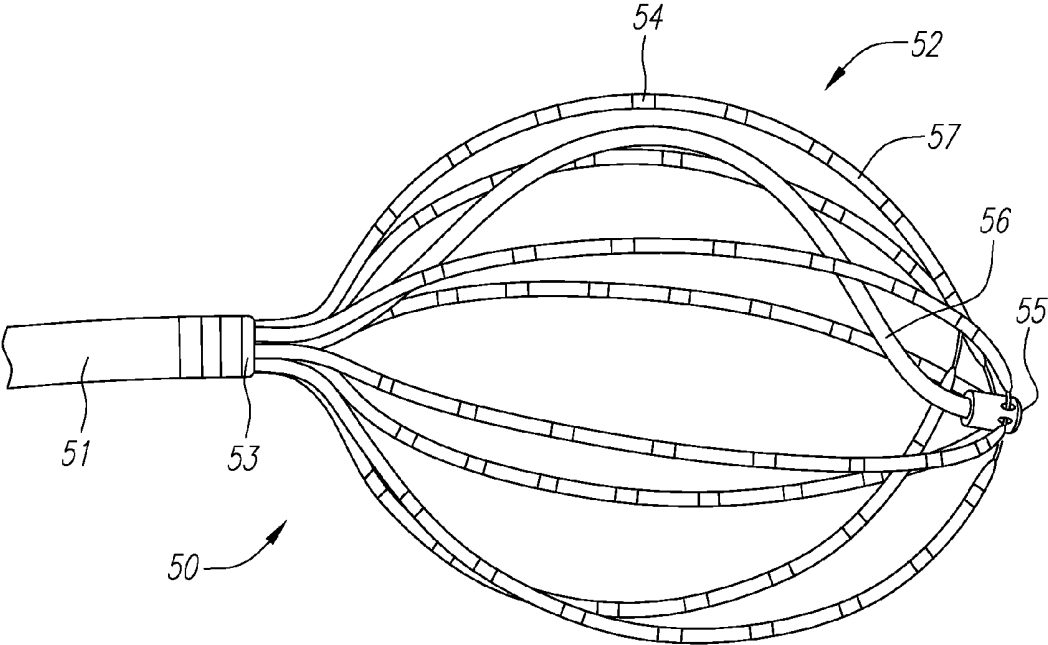

FIG. 3

Exemplary En.



FIG. 6B

Exemplary Ea.

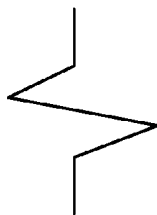

FIG. 6C

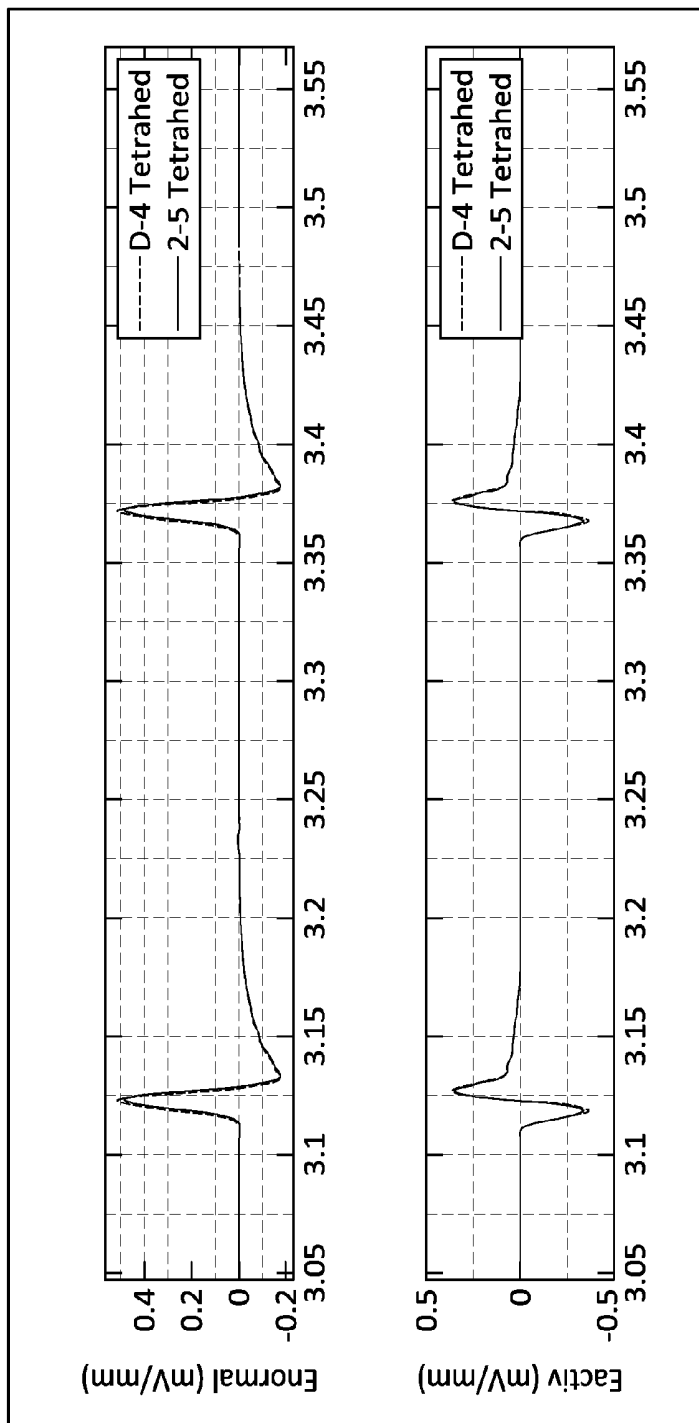

FIG. 6A

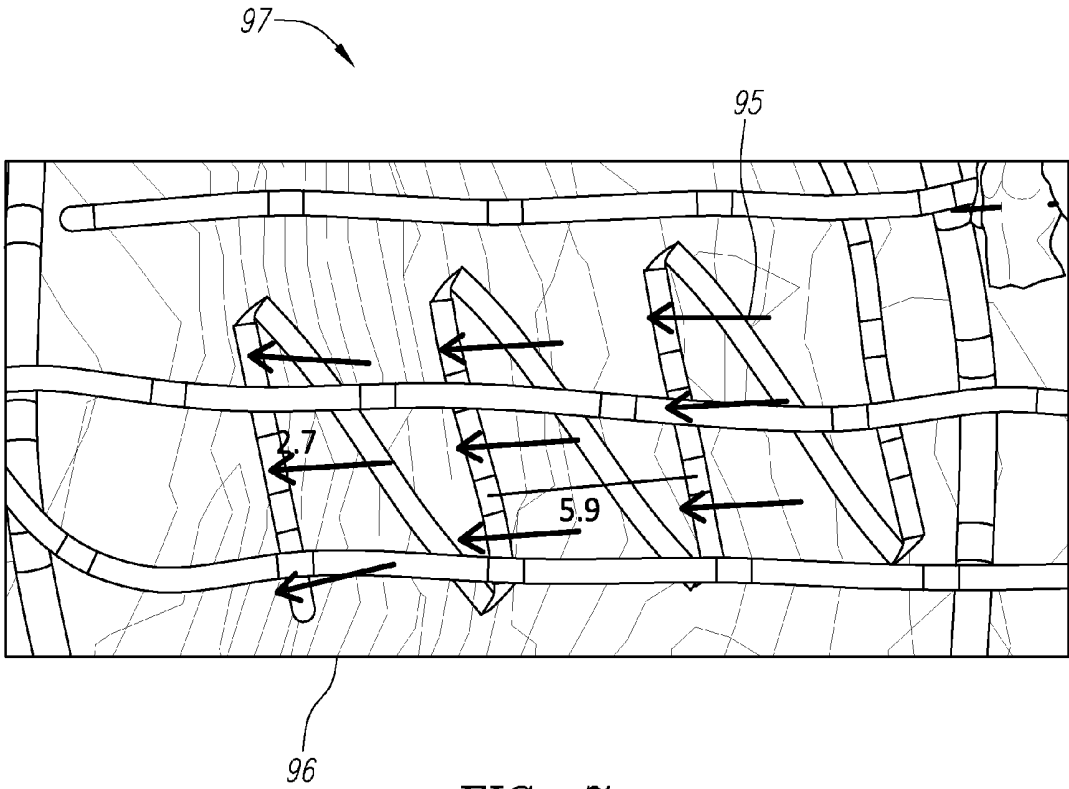

FIG. 7

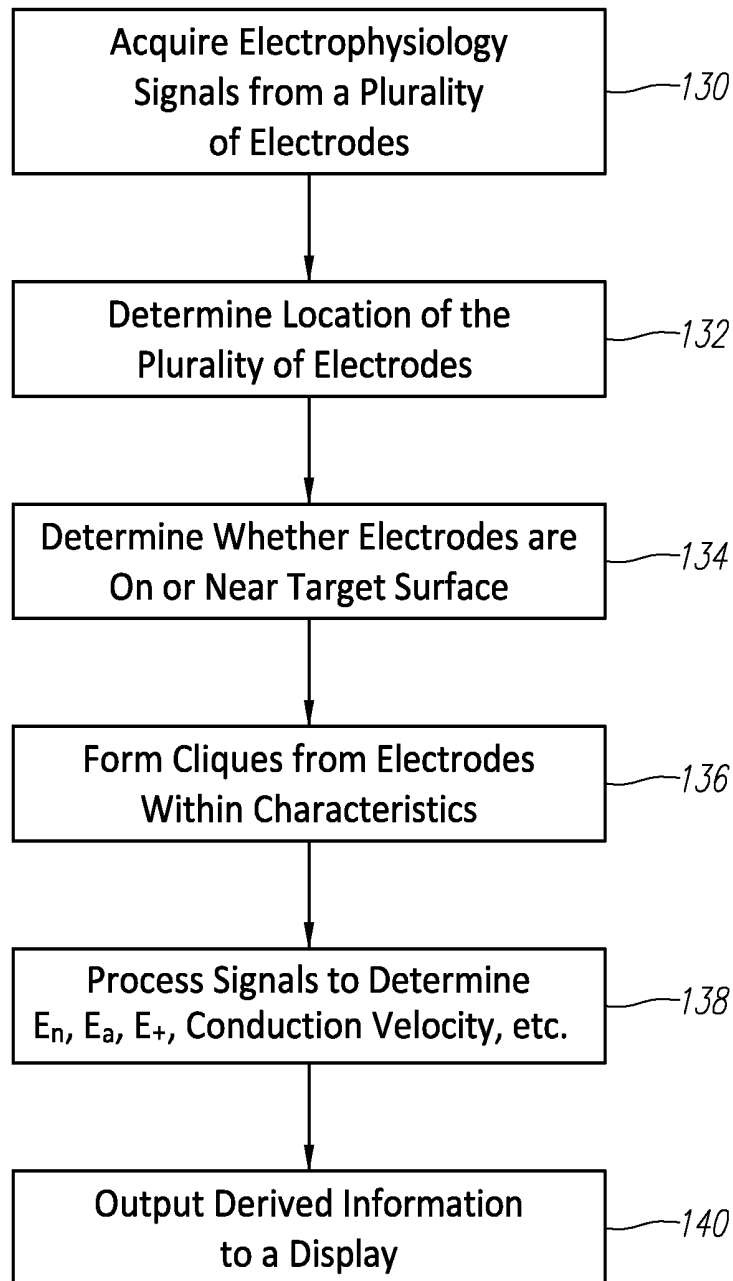

FIG. 8

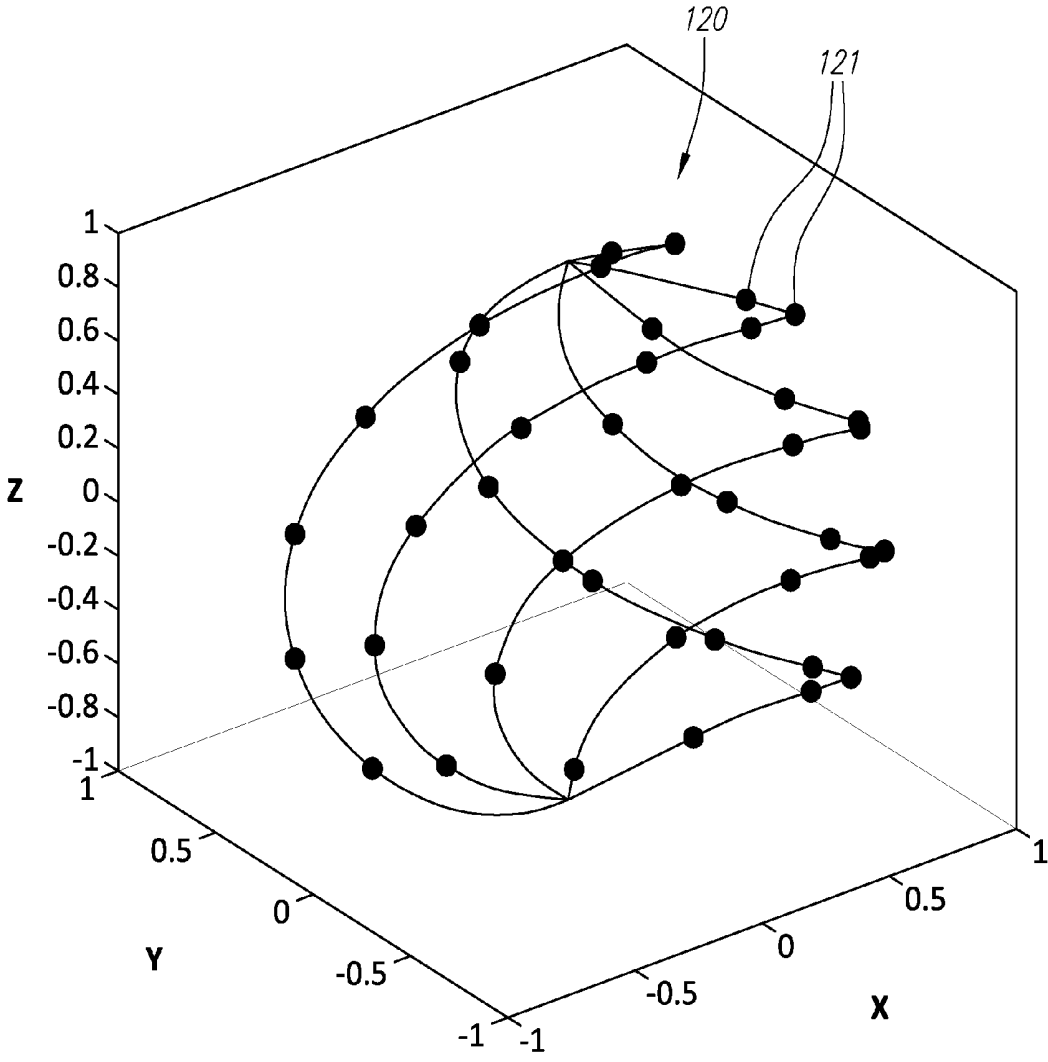

FIG. 9

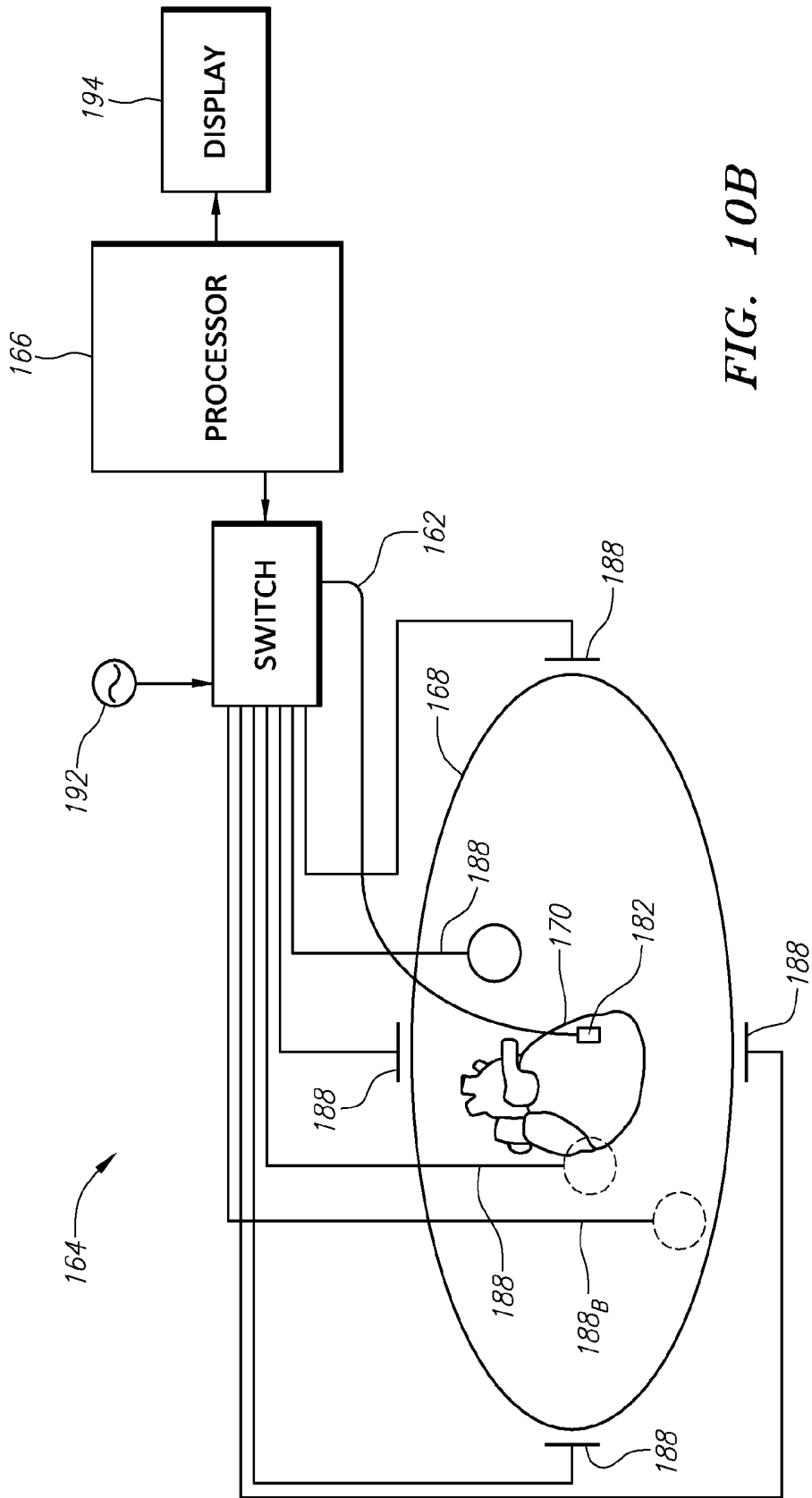

FIG. 10B

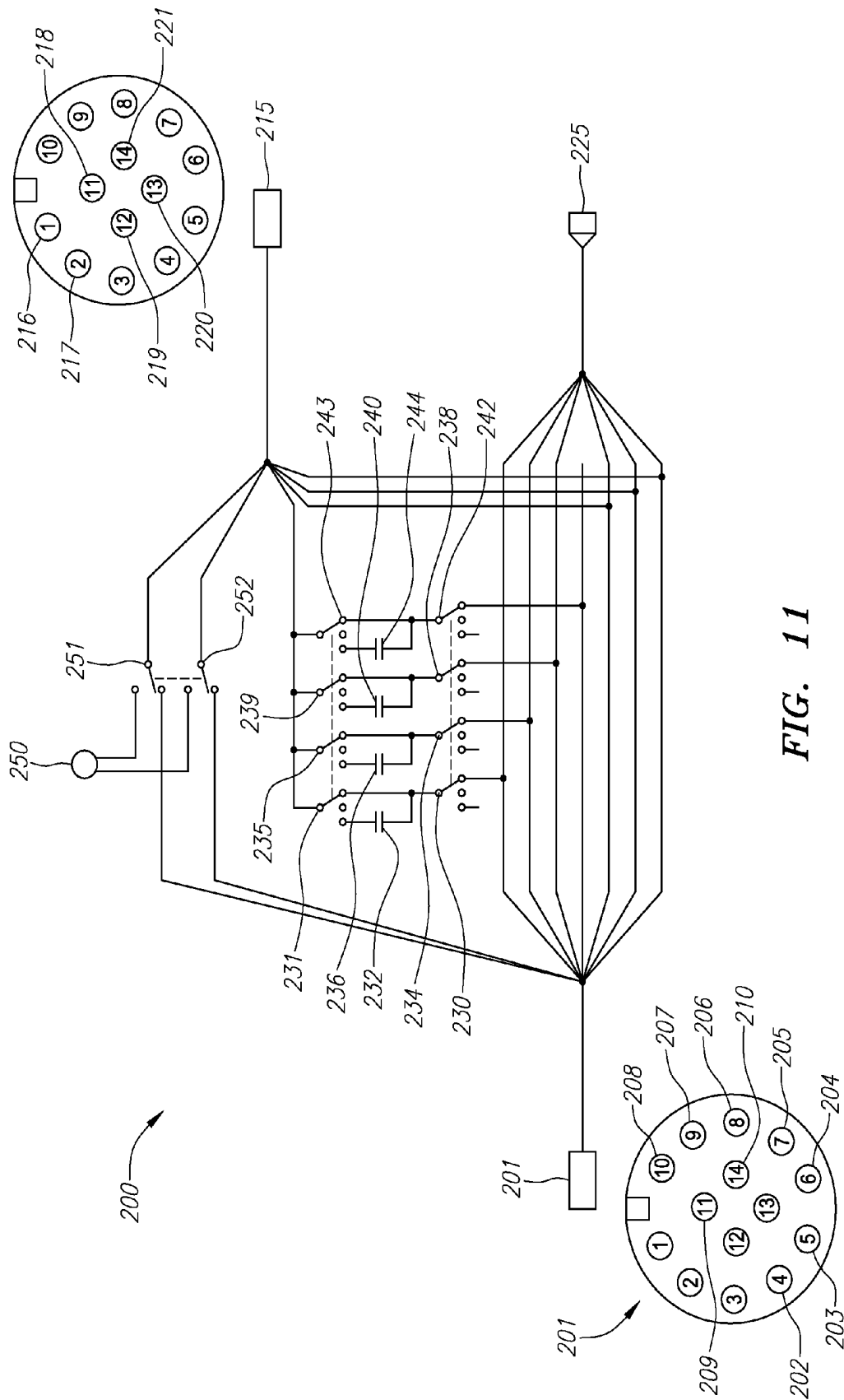

FIG. 11

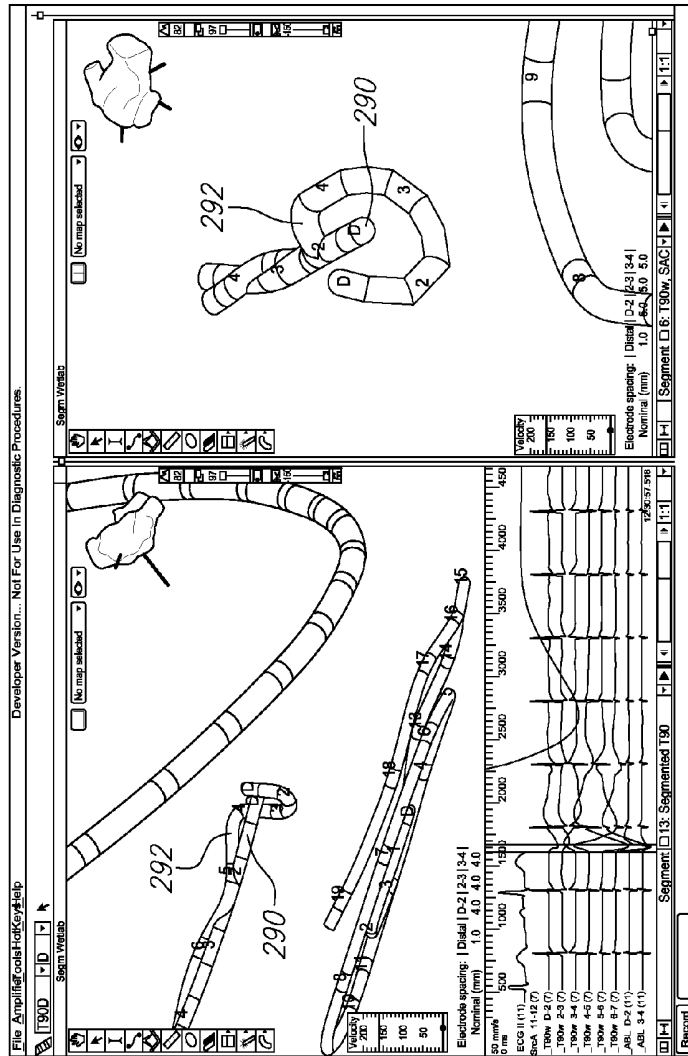

FIG. 12B

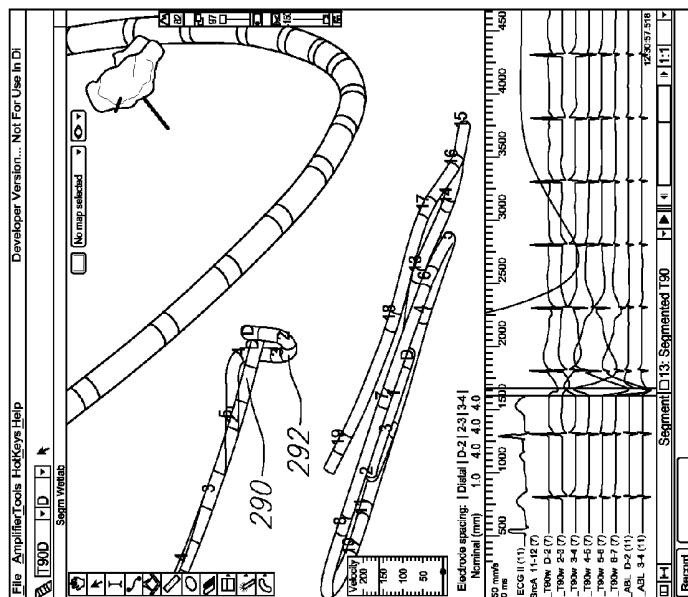

FIG. 12A

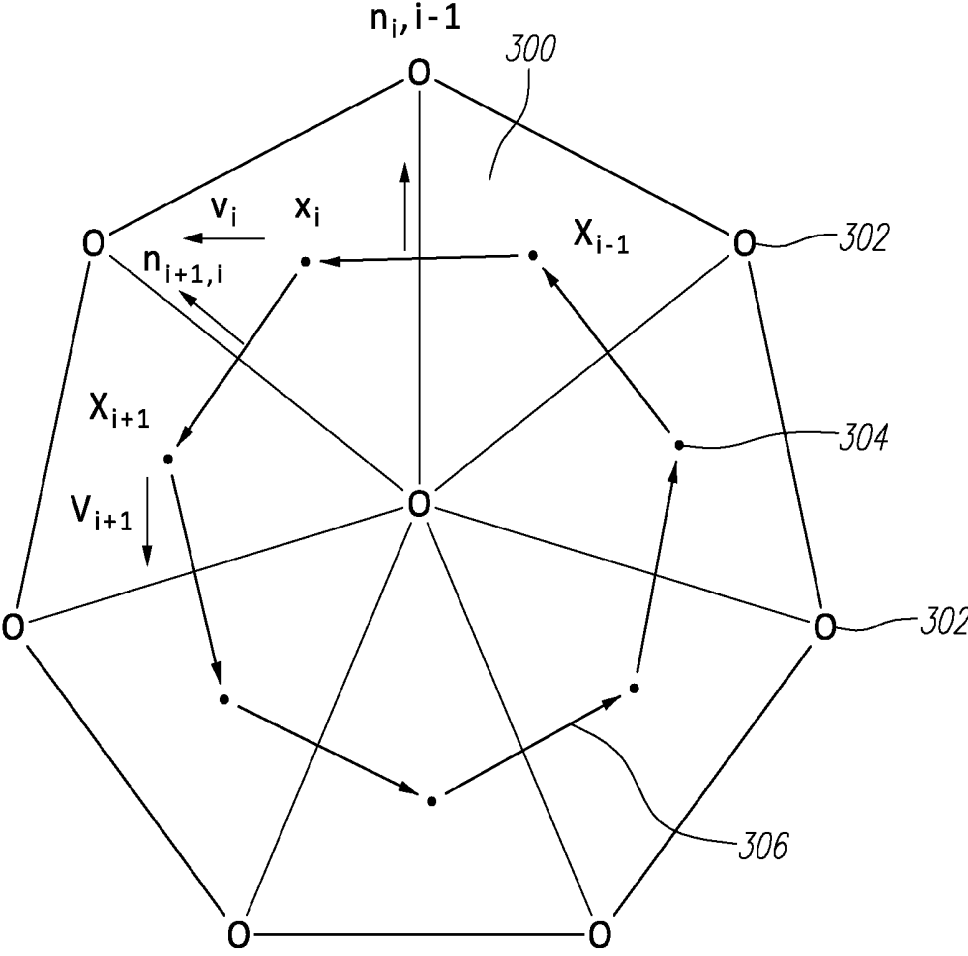

FIG. 13

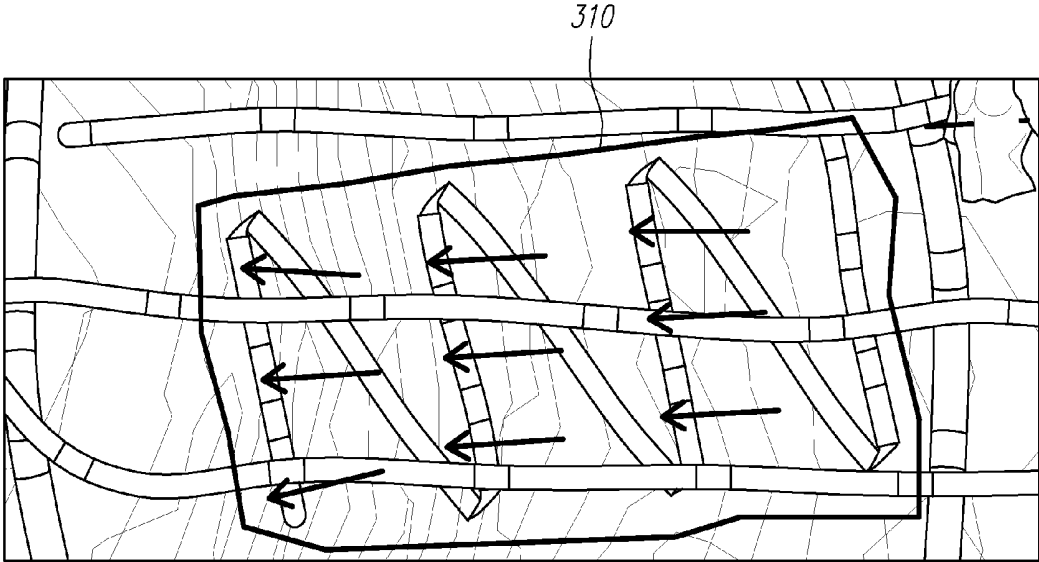

FIG. 14A

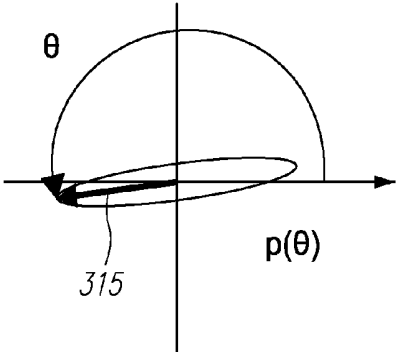
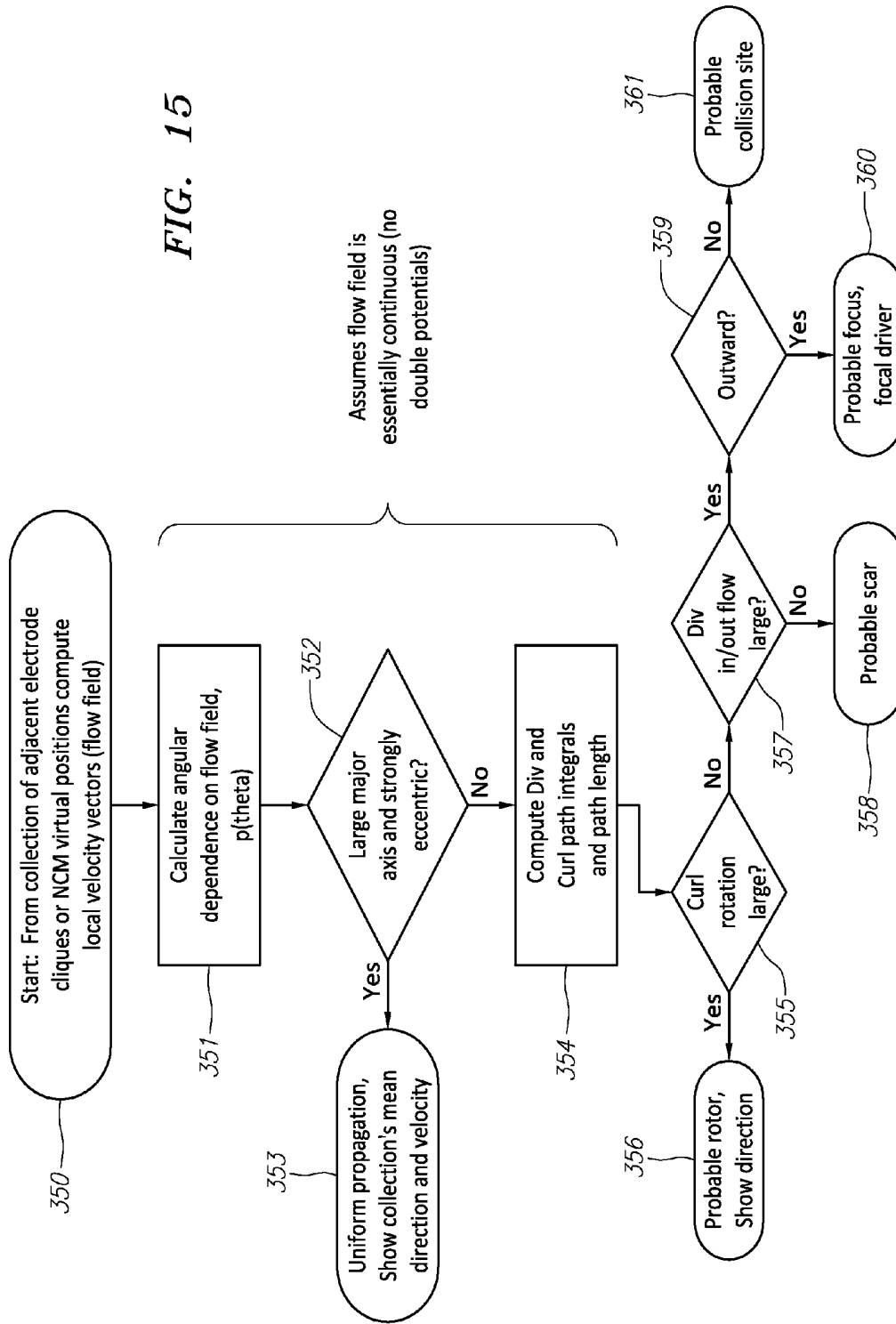

FIG. 14B

FIG. 15



	P(θ)	CURL	DIV
Uniform Propagation	Strong and eccentric	Small	Small
Rotors	Weak	Large	Small
Focal Source	Weak	Small	Large and Positive
Collision Site	Weak	Small	Large and Negative
Scar	Weak	Small	Small

370

371

372

373

374

FIG. 16

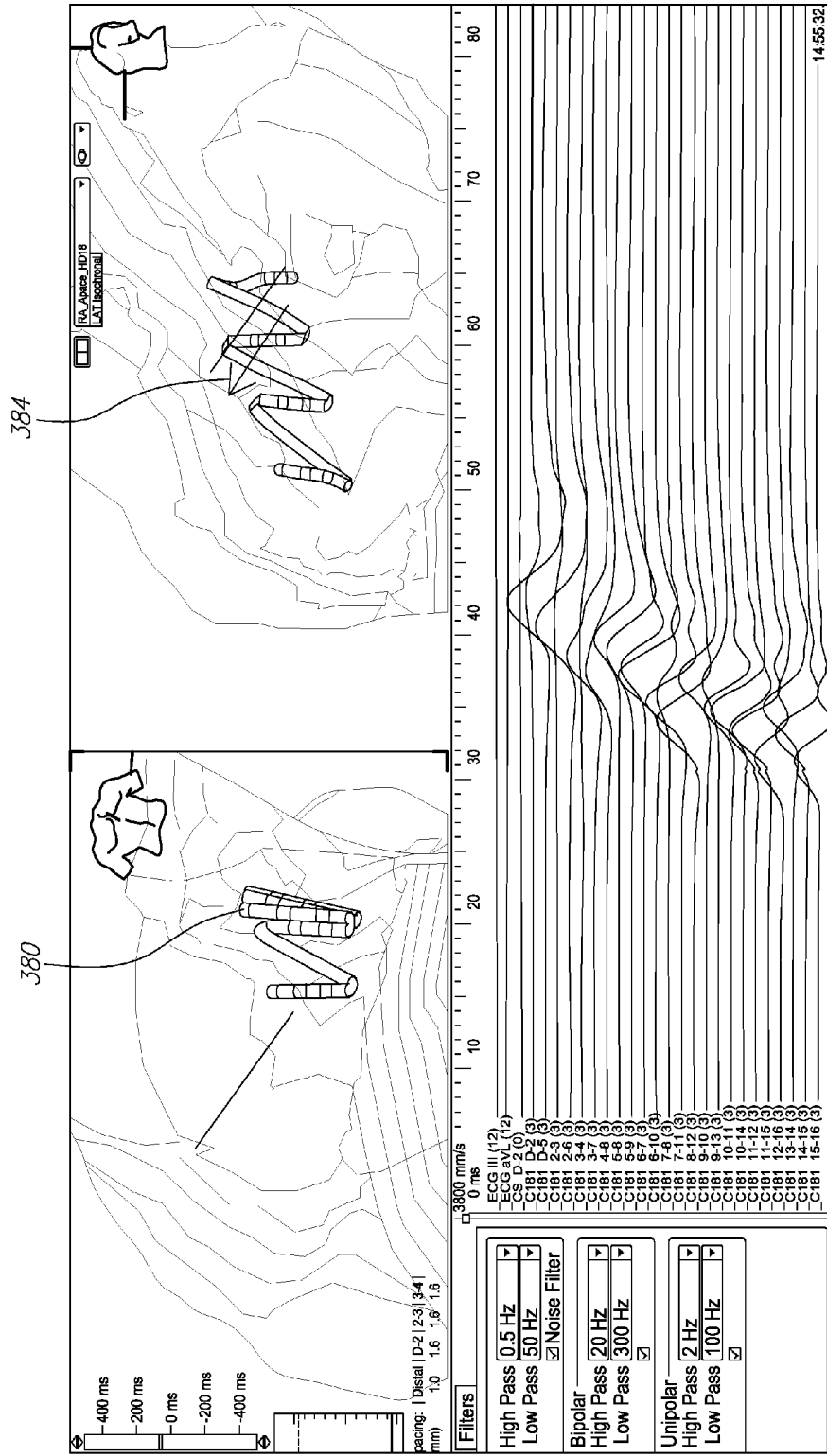

FIG. 17

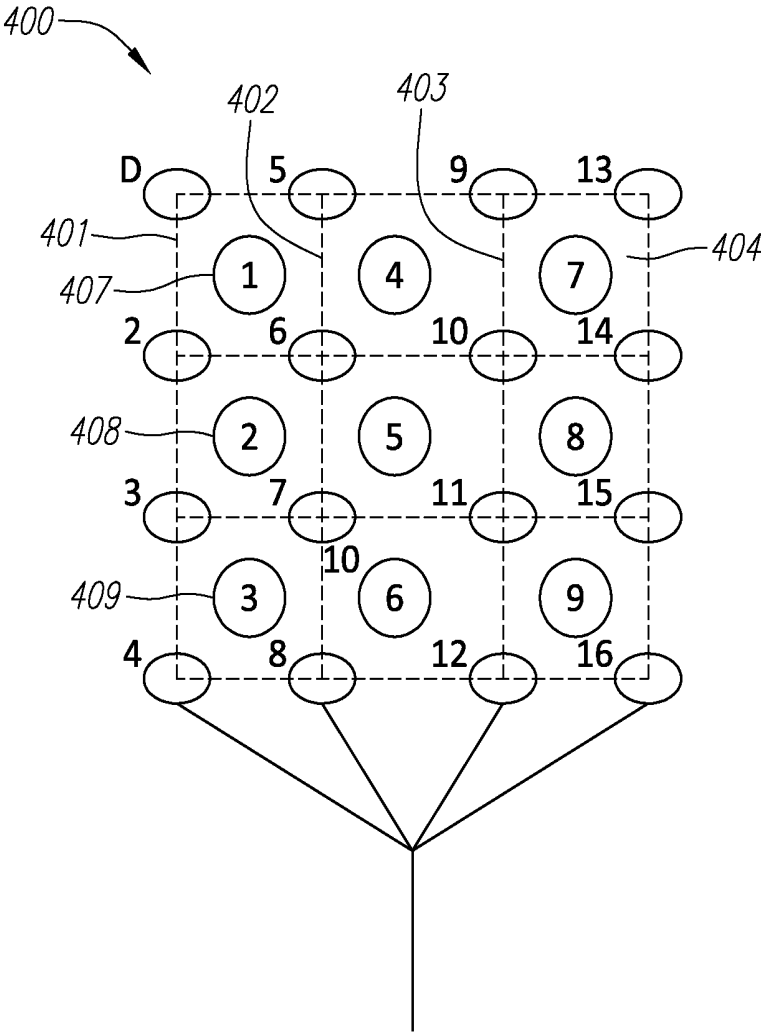

FIG. 18

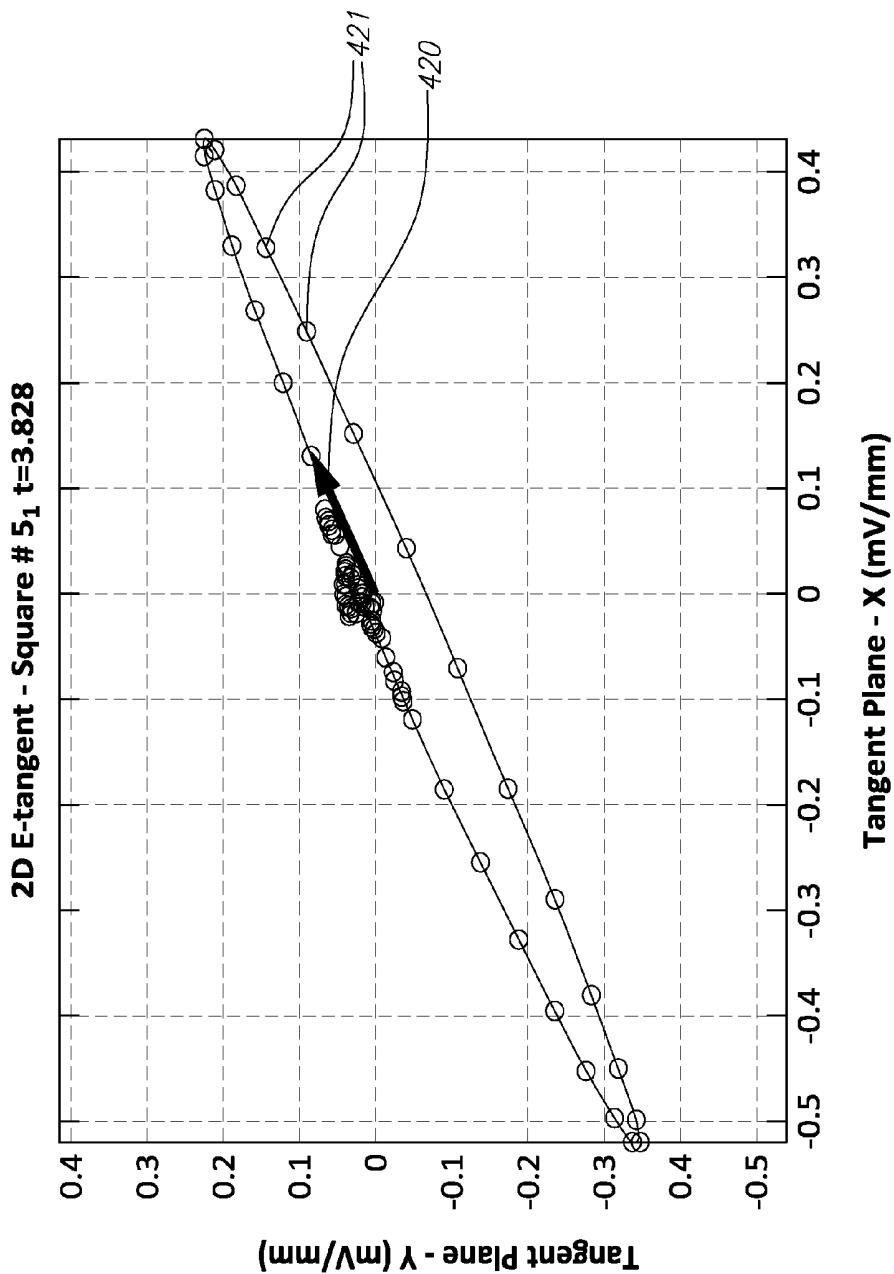

FIG. 19

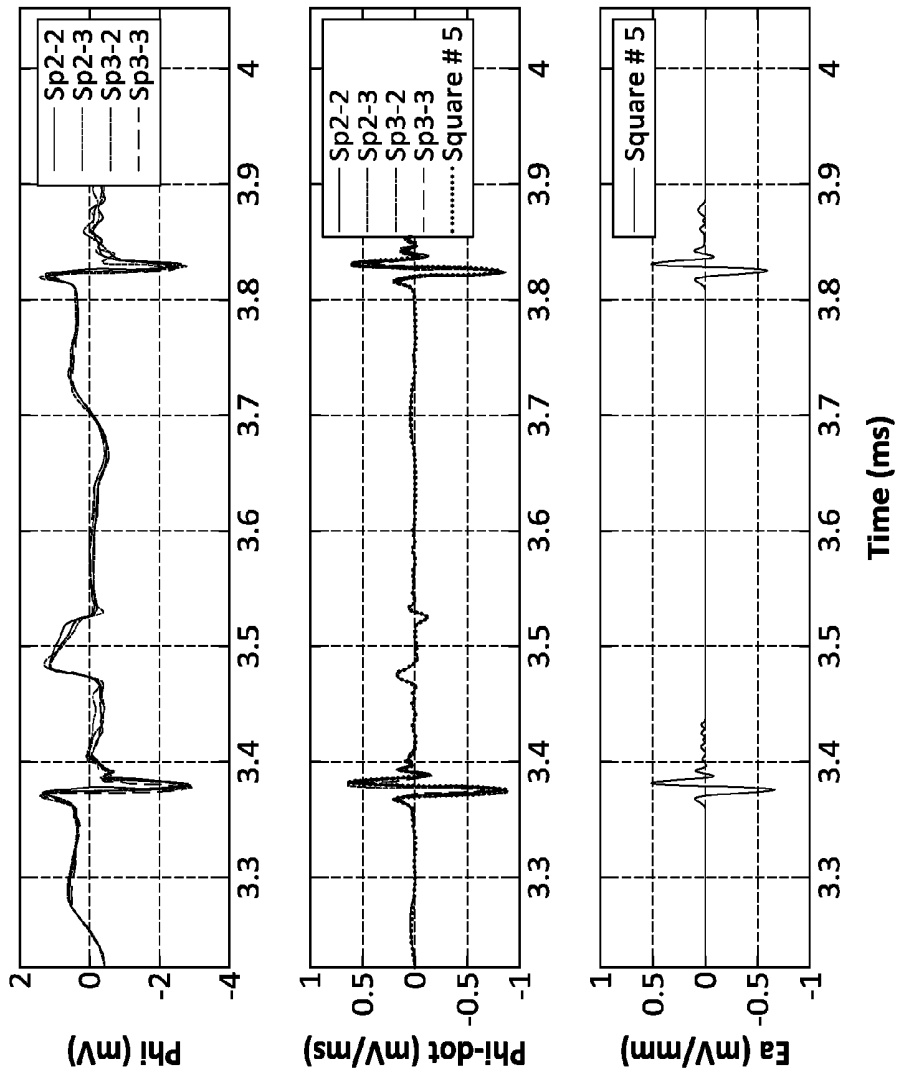

FIG. 20A

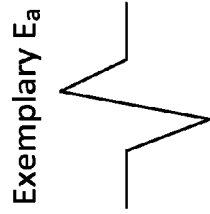

FIG. 20B

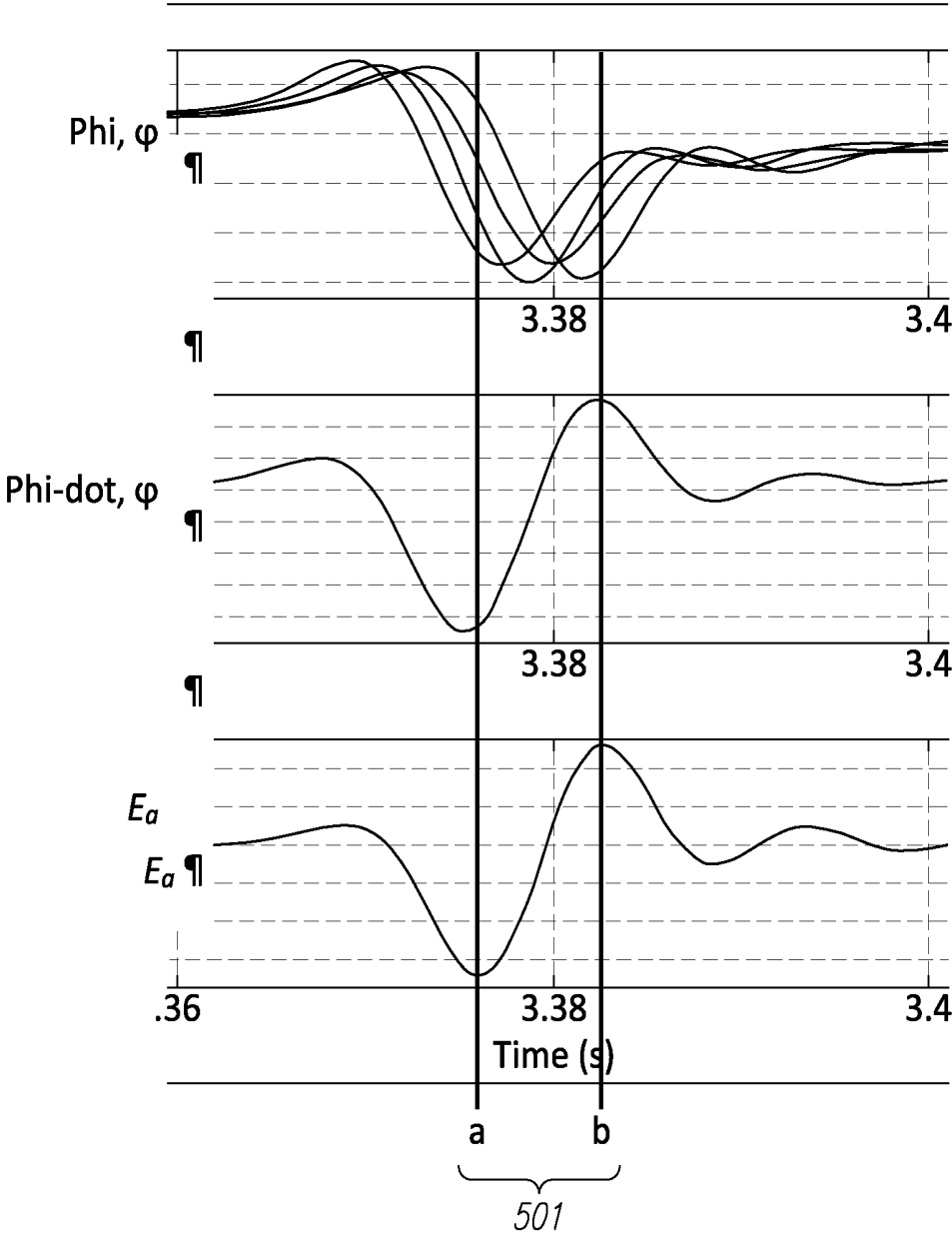

FIG. 21

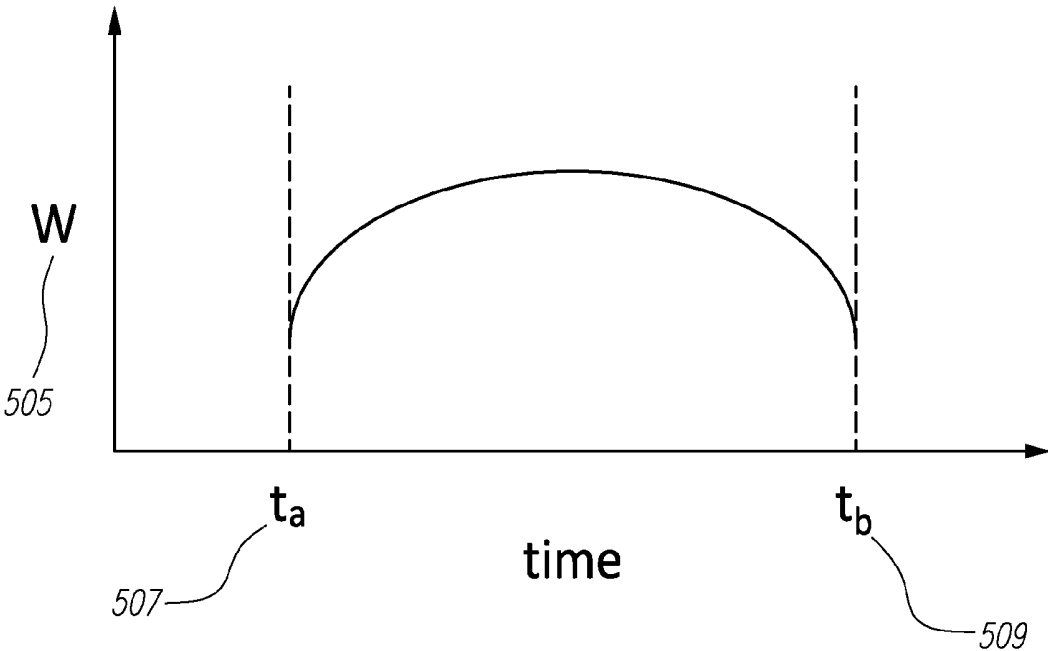

FIG. 22

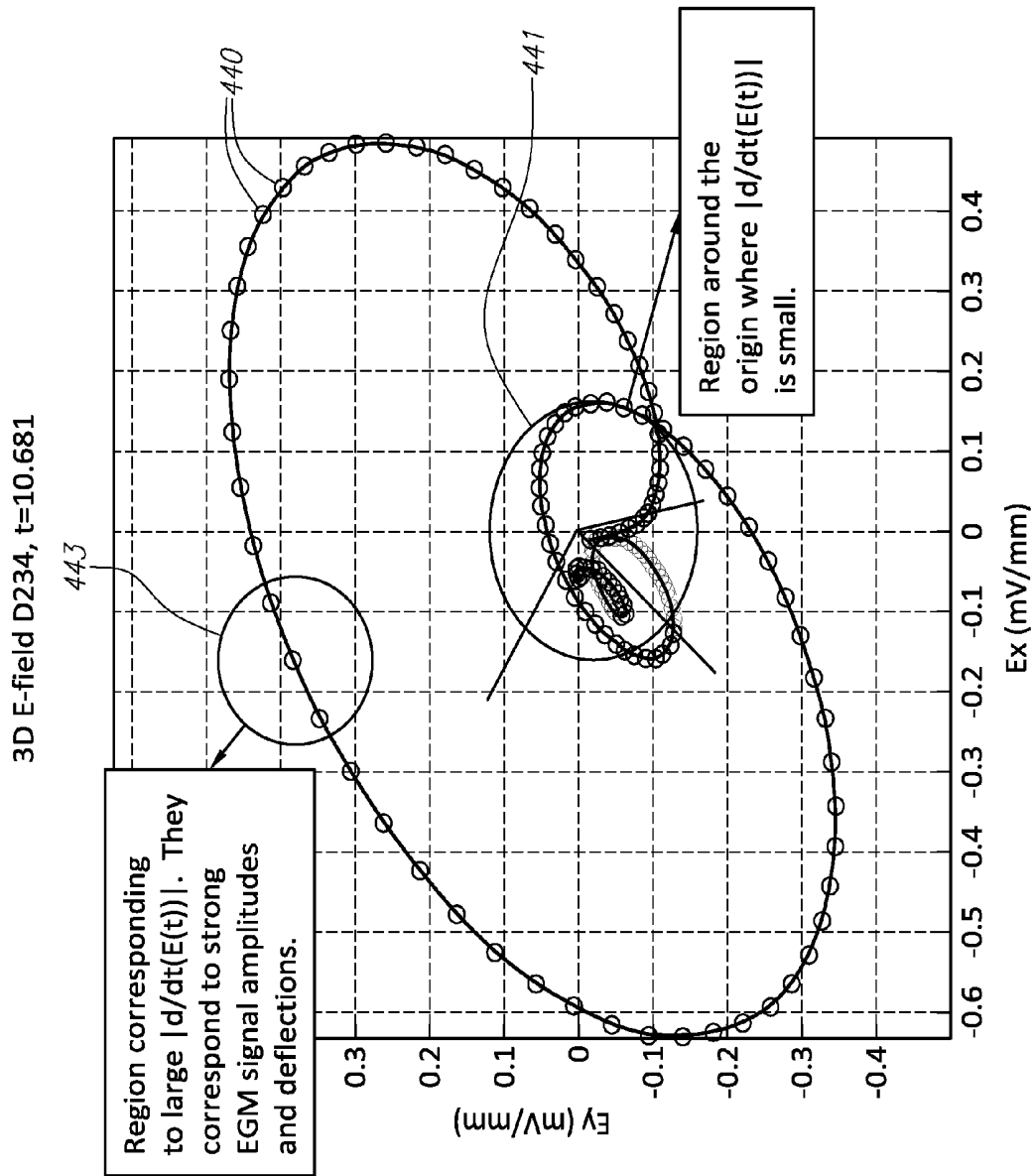

FIG. 23

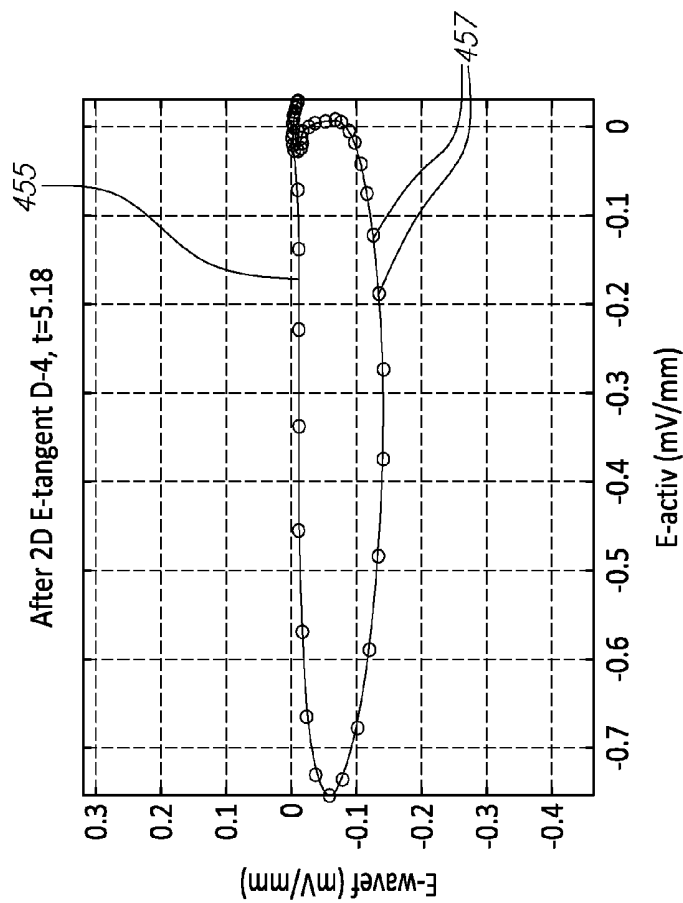

FIG. 24A

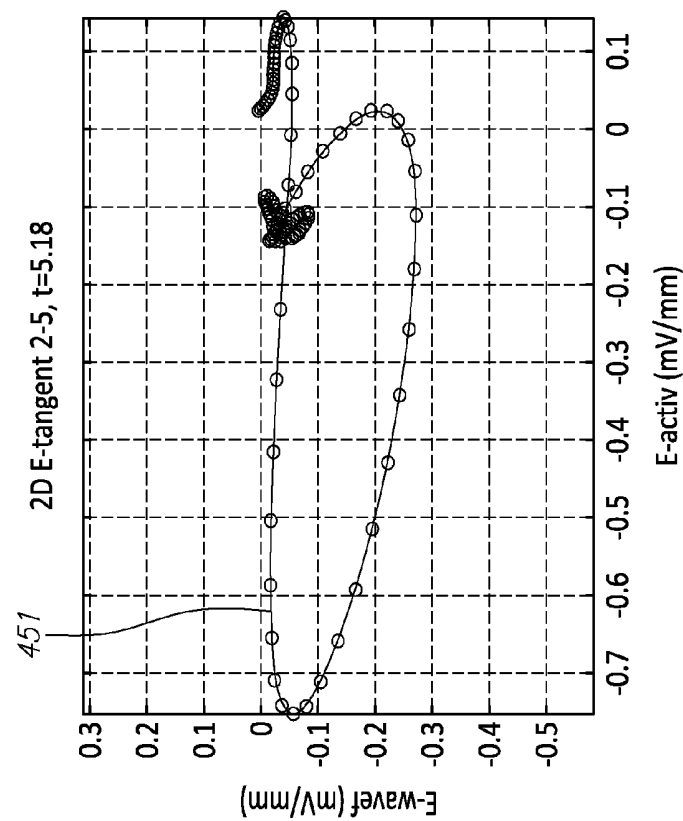

FIG. 24B

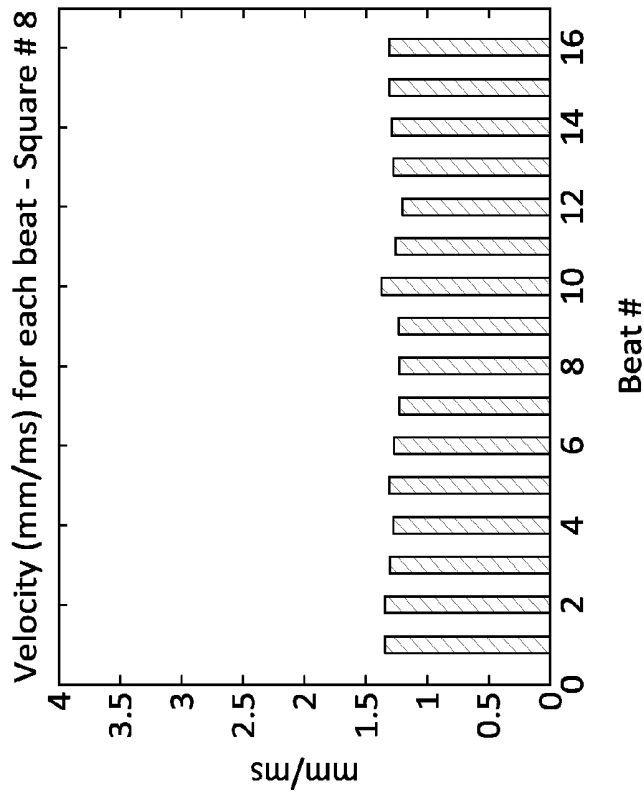

FIG. 25B

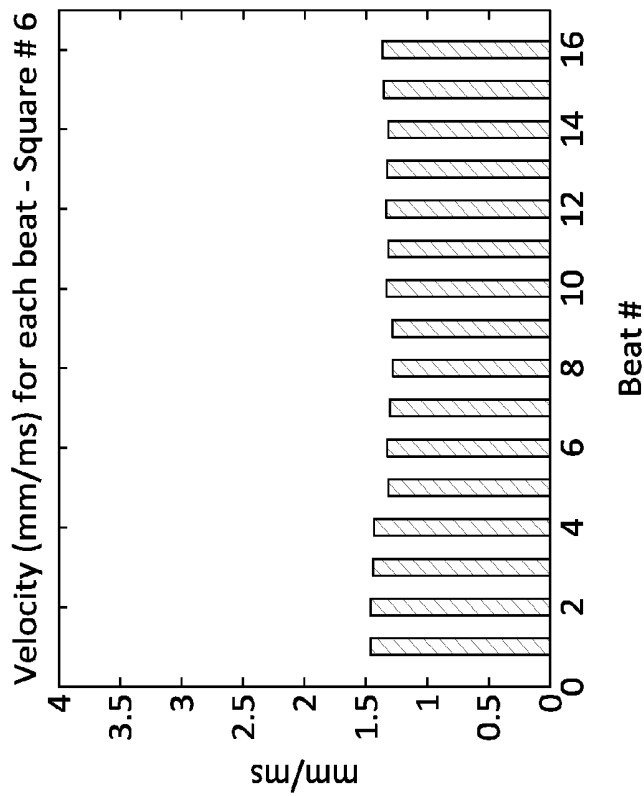

FIG. 25A

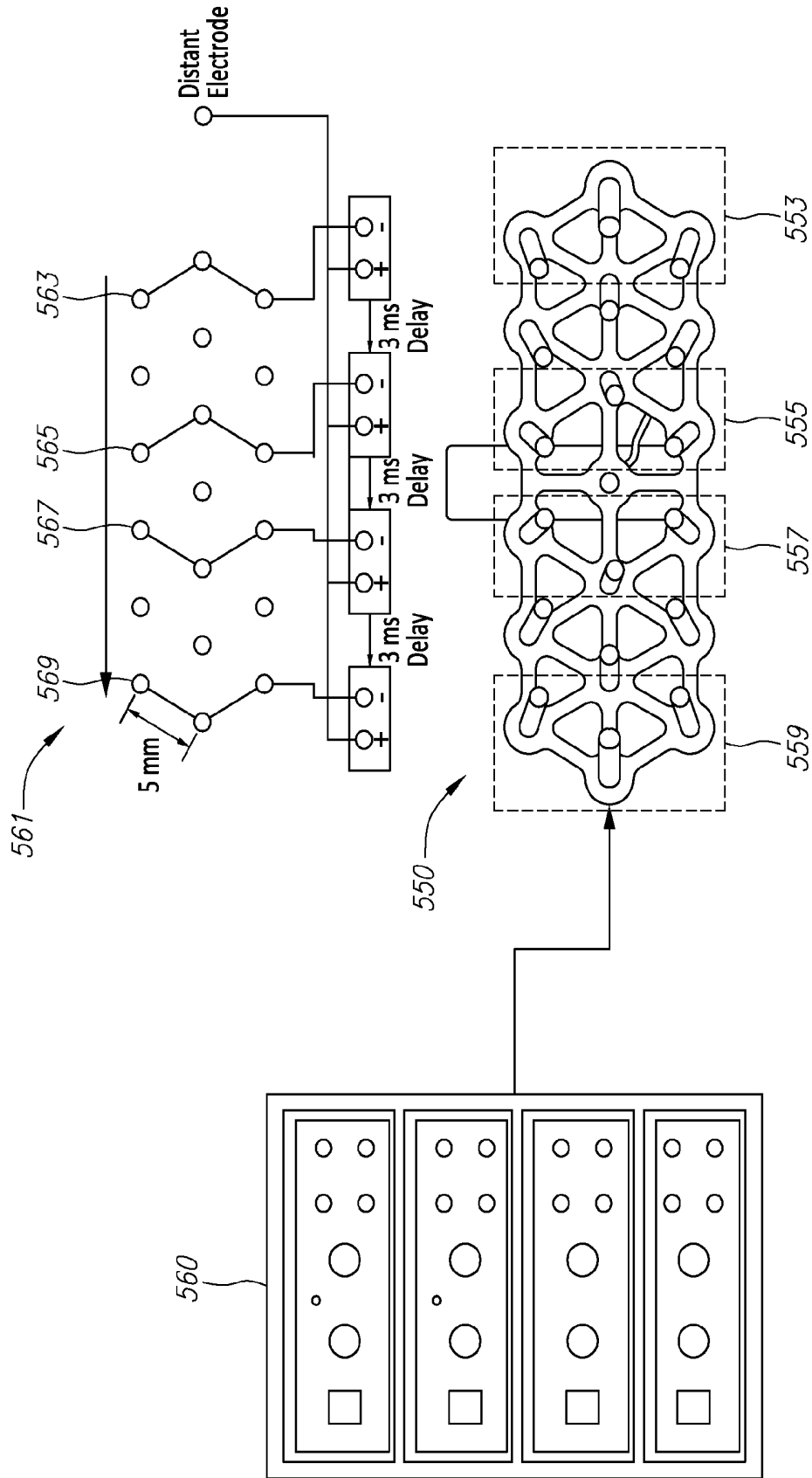

FIG. 26

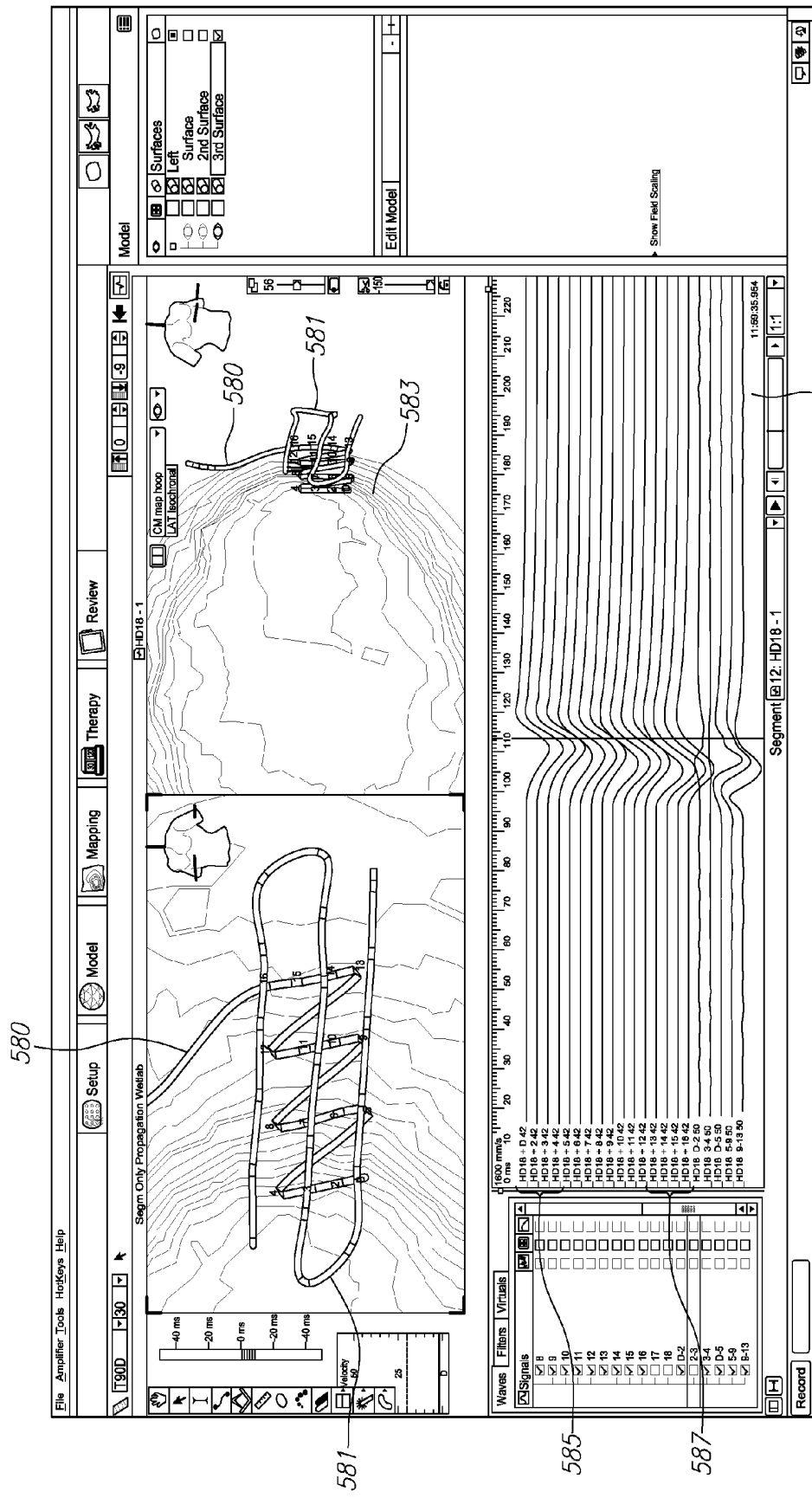

FIG. 27

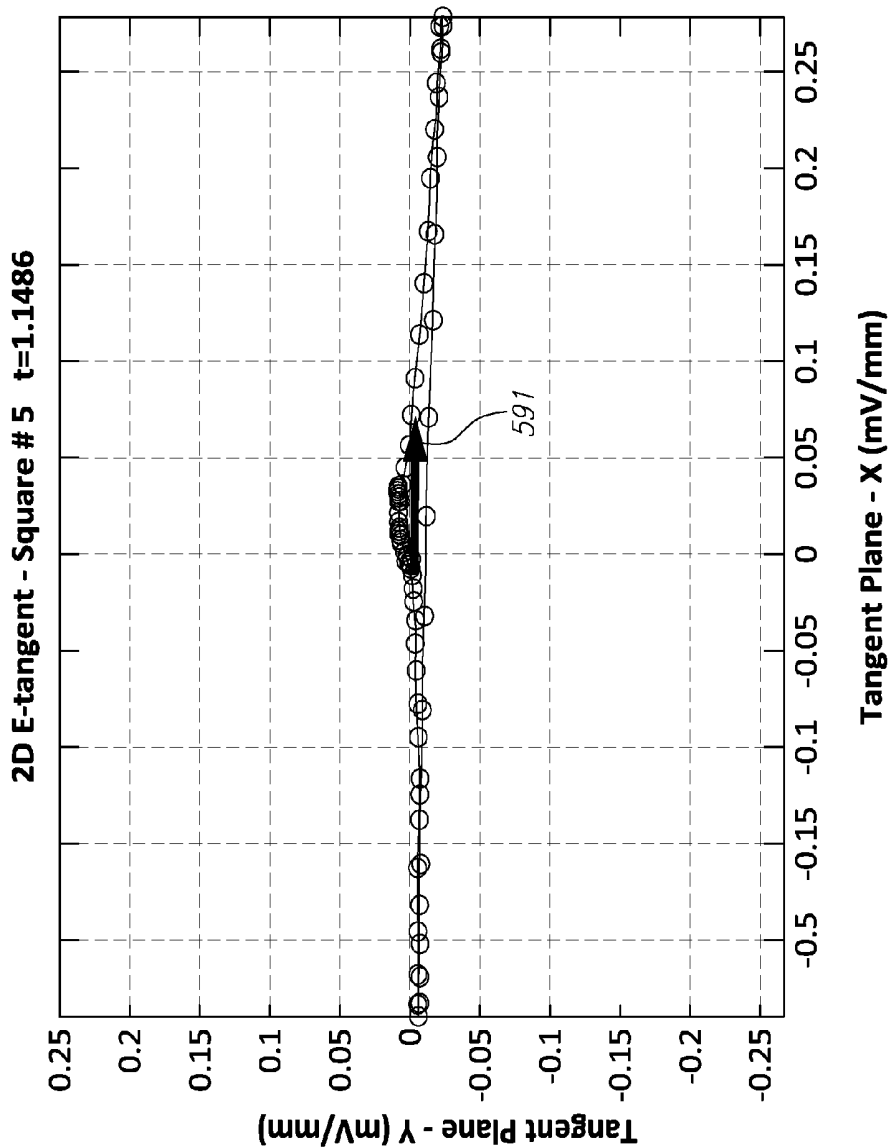

FIG. 28

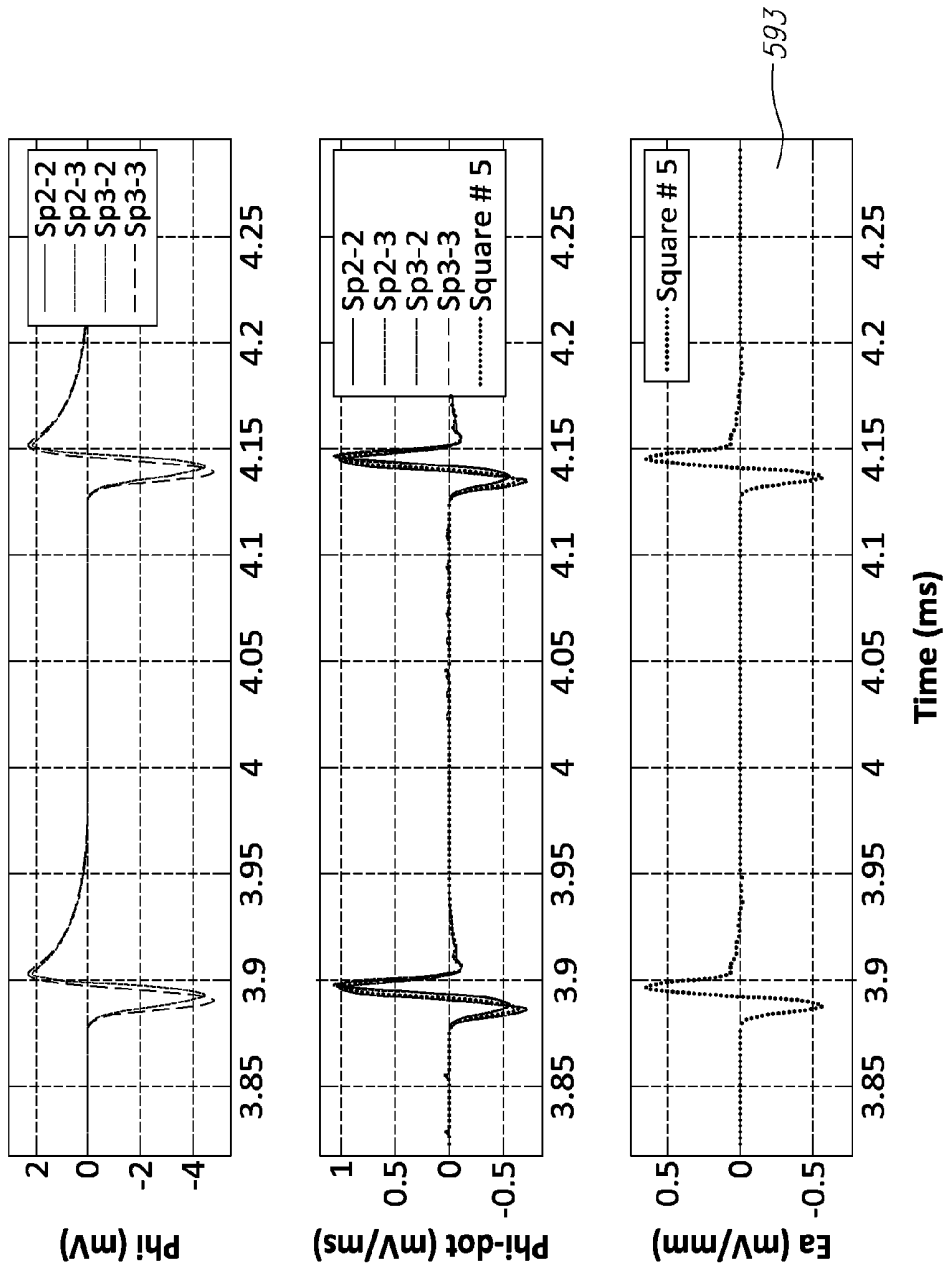

FIG. 29

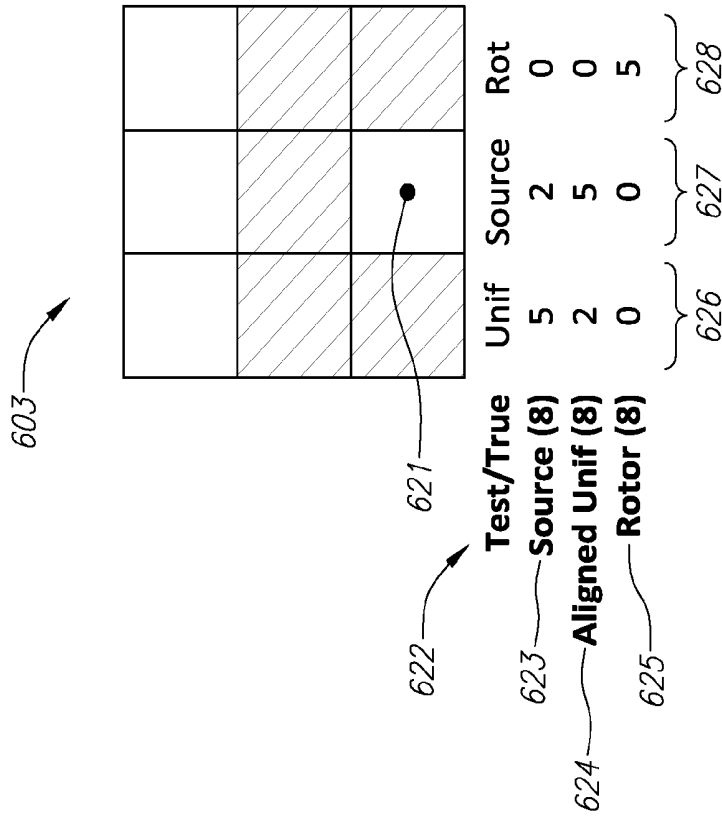

FIG. 30A

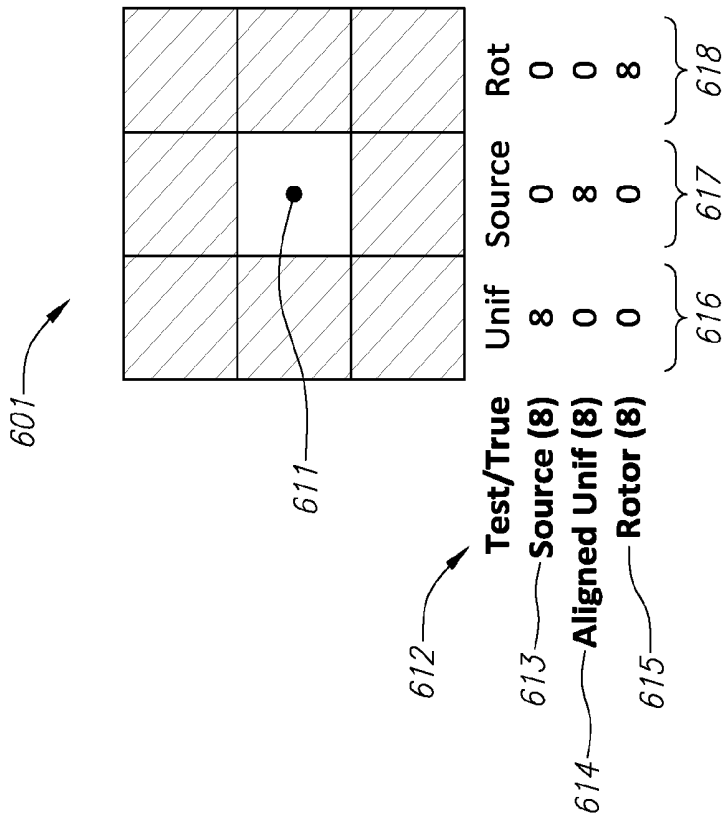

FIG. 30B

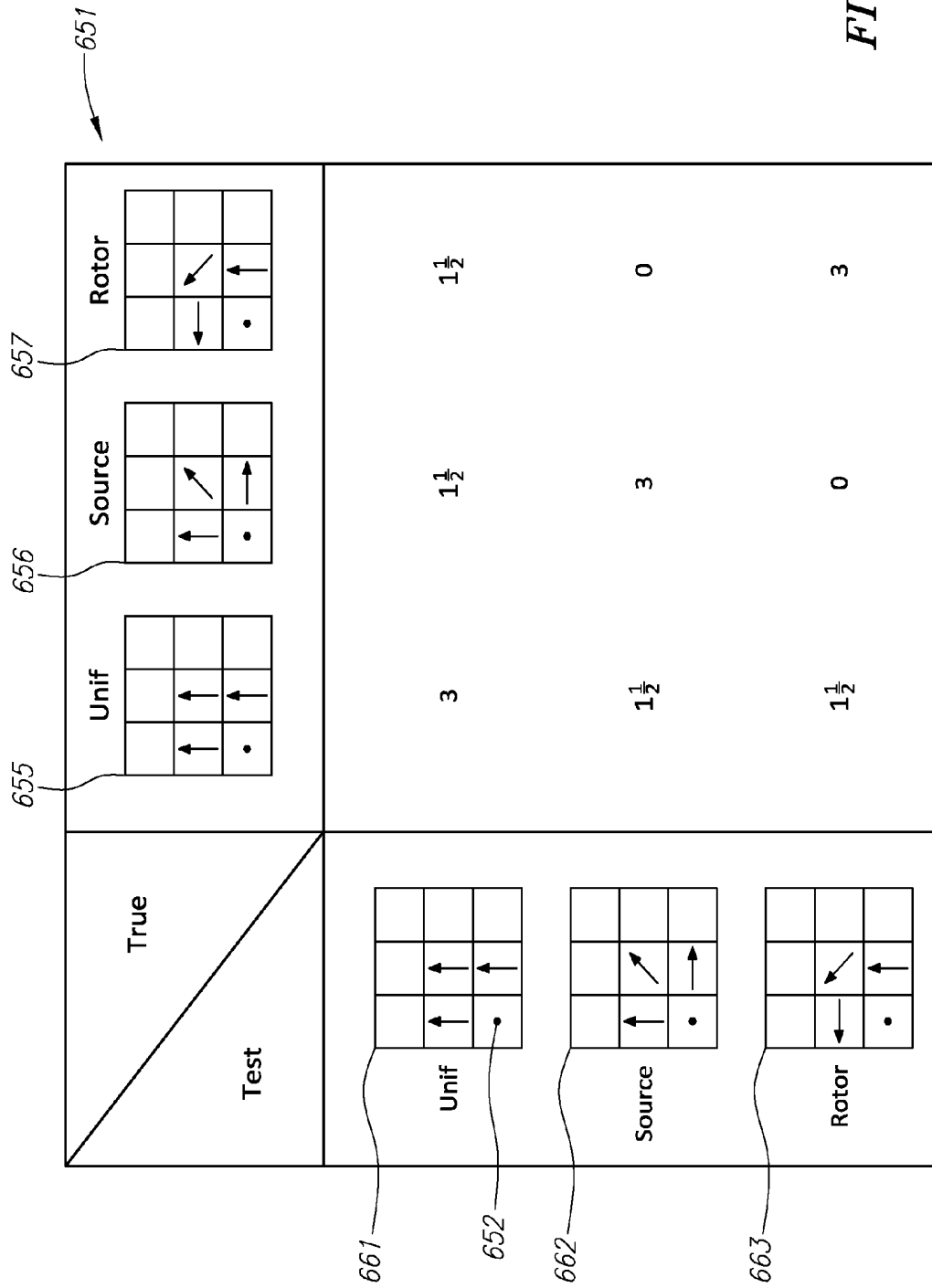

FIG. 31

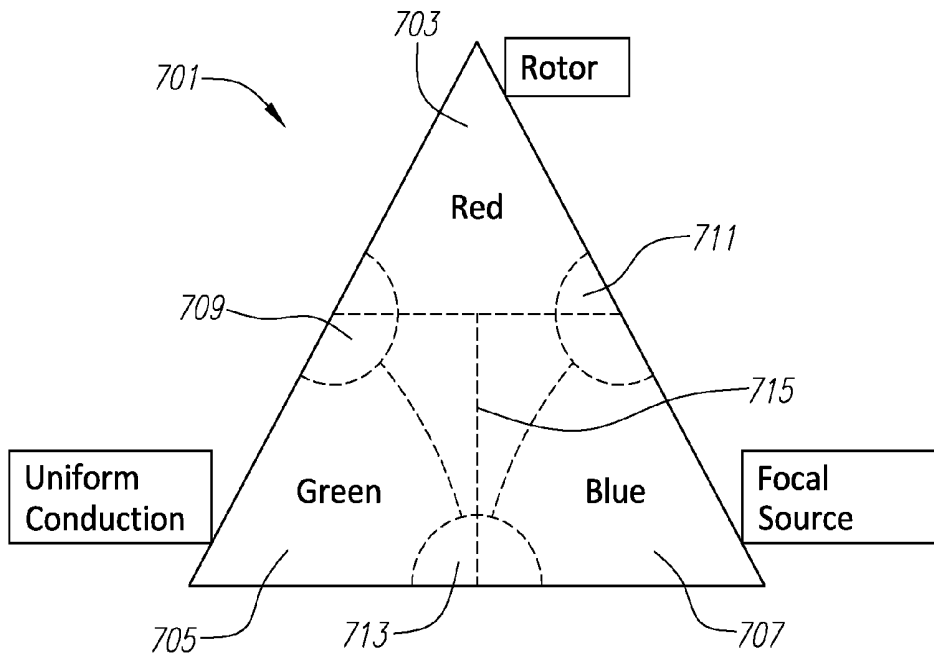

FIG. 32

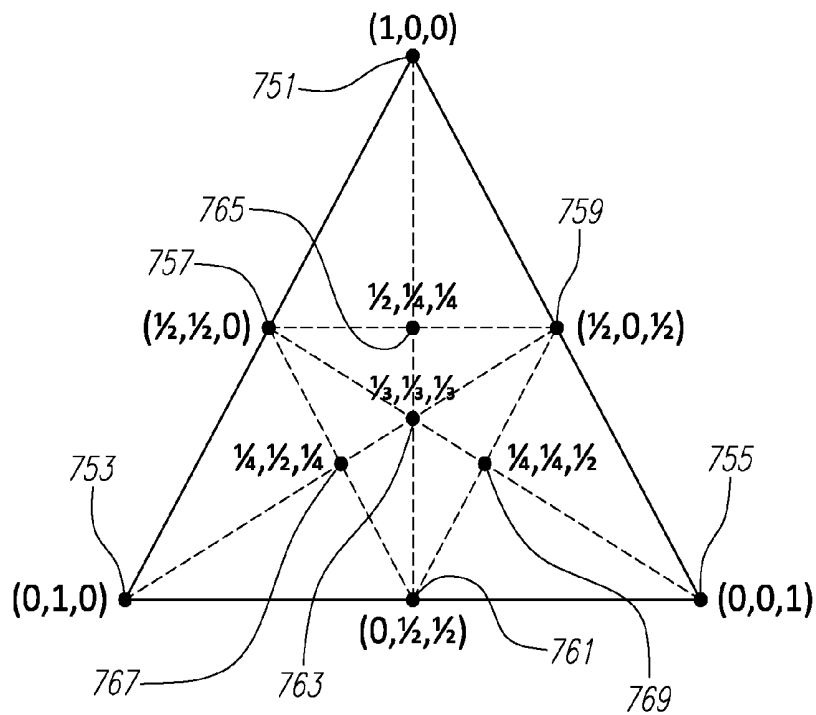
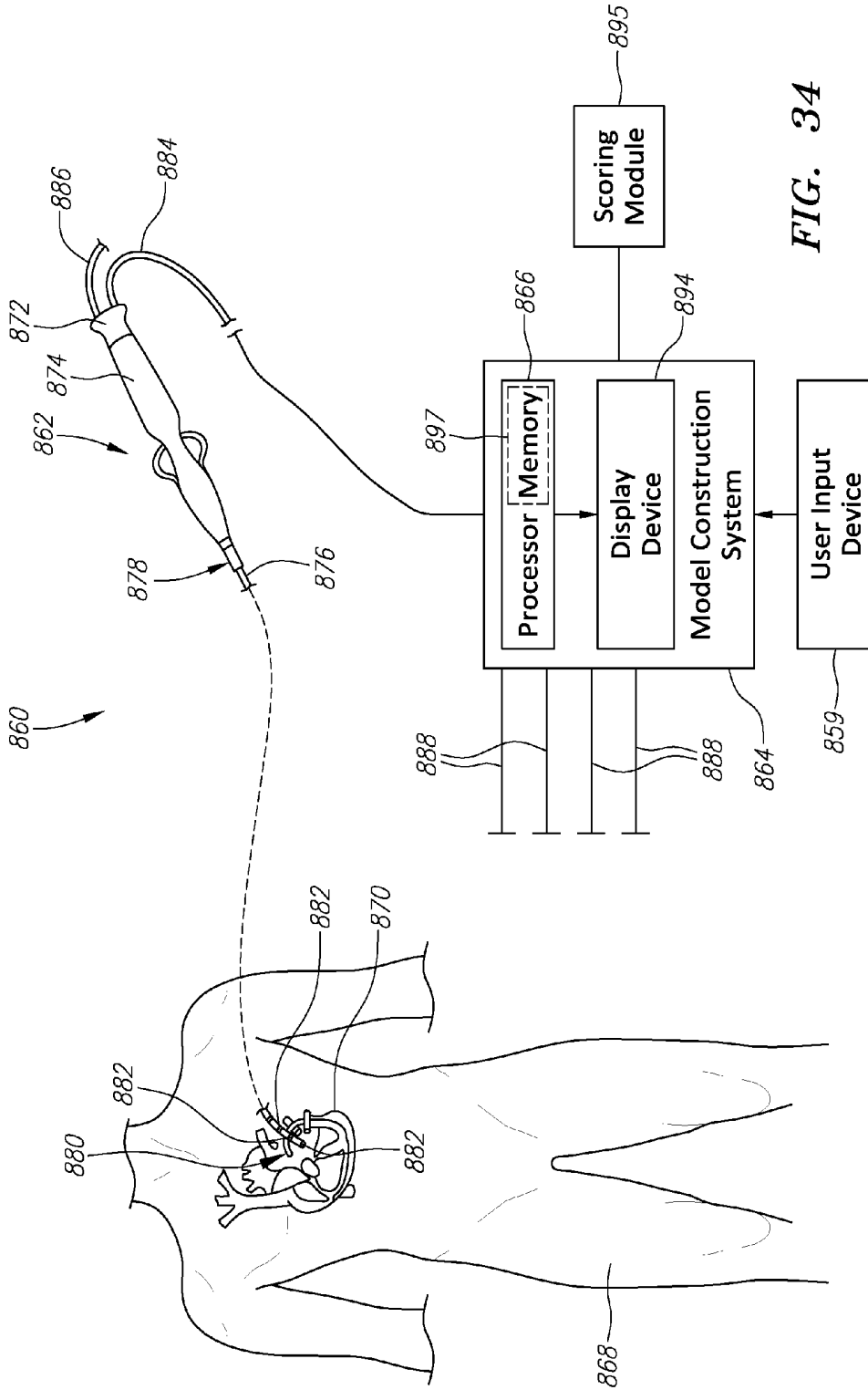

FIG. 33



**SYSTEM AND METHOD FOR LOCAL
ELECTROPHYSIOLOGICAL
CHARACTERIZATION OF CARDIAC
SUBSTRATE USING MULTI-ELECTRODE
CATHETERS**

CROSS-REFERENCE TO RELATED
APPLICATIONS

[0001] This application claims the benefit of U.S. provisional application No. 61/944,426, filed 25 Feb. 2014, which is hereby incorporated by reference as though fully set forth herein.

BACKGROUND

[0002] a. Field

[0003] This disclosure relates to systems, apparatuses and methods for utilizing electrode spatial arrangements within a mapping system. In particular, the instant disclosure relates to systems, apparatuses and methods for characterizing cardiac conduction conditions in a catheter orientation independent manner using electrode spatial arrangements in 3D mapping systems.

[0004] b. Background

[0005] Electrophysiology (EP) catheters are used in a variety of diagnostic, therapeutic, and/or mapping and ablation procedures to diagnose and/or correct conditions such as atrial or ventricular arrhythmias, including for example, ectopic atrial tachycardia, atrial fibrillation, and atrial flutter. Arrhythmias can create a variety of conditions including irregular heart rates, loss of synchronous atrioventricular contractions and stasis of blood flow in a chamber of a heart which can lead to a variety of symptomatic and asymptomatic ailments and even death.

[0006] Typically, a catheter is deployed and manipulated through a patient's vasculature to the intended site, for example, a site within a patient's heart. The catheter carries one or more electrodes that can be used for cardiac mapping or diagnosis, ablation and/or other therapy delivery modes, or both, for example. Once at the intended site, treatment can include, for example, radio frequency (RF) ablation, cryoablation, laser ablation, chemical ablation, high-intensity focused ultrasound-based ablation, microwave ablation, and/or other ablation treatments. The catheter imparts ablative energy to cardiac tissue to create one or more lesions in the cardiac tissue. This lesion disrupts undesirable cardiac activation pathways and thereby limits, corrals, or prevents errant conduction signals that can form the basis for arrhythmias.

[0007] To position a catheter at a desired site within the body, some type of navigation may be used, such as using mechanical steering features incorporated into the catheter (or a sheath). In some examples, medical personnel may manually manipulate and/or operate the catheter using the mechanical steering features.

[0008] A navigating system may be used for visualization and to facilitate the advancement of catheters through a patient's vasculature to specific locations within the body. Such navigating systems may include, for example, electric and/or magnetic field based positioning and navigating systems that are able to determine the position and orientation of the catheter (and similar devices) within the body.

[0009] Conduction disorders in the body can result from abnormal conduction in regions as small as 1-4 mm. In

addition, ablation in these regions must be restricted to the pathological tissue to preserve electrical and mechanical function, particularly with ventricular arrhythmias. Today, many catheters employ electrode pairs spaced greater than 4 mm apart which can make it difficult to reliably allow discrimination or localization of defects. Even when the electrodes are more closely spaced, around 1 mm to around 2 mm, the orientation of the pair of electrodes is a prominent factor in the amplitude and morphology of the resulting signals.

[0010] The foregoing discussion is intended only to illustrate the present field and should not be taken as a disavowal of claim scope.

BRIEF SUMMARY

[0011] In an embodiment, a system for determining electrophysiological data comprises an electronic control unit configured to receive electrogram data for a set of electrodes, receive position and orientation information for the set of electrodes from a mapping system, determine catheter orientation independent information of a tissue, and output the orientation independent information to the mapping system. In some embodiments, the electrode arrangements facilitate multiple simultaneous such assessments and the mapping system may process the spatial pattern of catheter orientation independent information to recognize certain arrhythmia patterns.

[0012] In one embodiment, a system for determining electrophysiological data can comprise an electronic control unit configured to acquire electrophysiology signals from a plurality of electrodes of one or more catheters, select at least one clique of electrodes from the plurality of electrodes to determine a plurality of local E field data points, determine the location and orientation of the plurality of electrodes, process the electrophysiology signals from the at least one clique from a full set of bipole subcliques to derive the local E field data points associated with the at least one clique of electrodes, derive at least one orientation independent signal from the at least one clique of electrodes from the information content corresponding to weighted parts of electrogram signals, and display or output catheter orientation independent electrophysiologic information to a user or process.

[0013] In another embodiment, a method for determining electrophysiological data can comprise acquiring electrophysiology signals from a plurality of electrodes of one or more catheters, selecting at least one clique of electrodes from the plurality of electrodes to determine a plurality of local E field data points, determining the location and orientation of the plurality of electrodes, processing the electrophysiology signals from the at least one clique from a full set of bipole subcliques to derive the local E field data points associated with the at least one clique of electrodes, deriving at least one orientation independent signal from the at least one clique of electrodes from the information content corresponding to weighted parts of electrogram signals, and displaying or output catheter orientation independent electrophysiologic information to a user or process.

[0014] In yet another embodiment, a circuit box adapter can comprise circuitry to interface an electrode ablation catheter to both an RF generator and EP mapping system; the circuitry operable between a first state to allow a plurality of catheter electrodes to separately sense electrical signals in a first mode and a second state to emit energy from

a single output from an ablation generator in a second mode. In the first state, the circuitry is configured to allow passive isolation of the plurality of segmented catheter electrodes for operation in the first mode.

BRIEF DESCRIPTION OF THE DRAWINGS

[0015] FIG. 1 is an illustration of the morphology and amplitudes of bipoles obtained from a catheter.

[0016] FIG. 2A is an isometric view of one embodiment of a paddle catheter.

[0017] FIG. 2B is an isometric view of another embodiment of a paddle catheter.

[0018] FIG. 2C is an isometric view of another embodiment of a paddle catheter.

[0019] FIG. 3 is an isometric view of a basket catheter.

[0020] FIG. 4 is an illustration showing the activation, wavefront, surface normal, and conduction velocity directions for a traveling wave.

[0021] FIG. 5 is a schematic illustrating electrode location and clique geometry.

[0022] FIG. 6 is a graph depicting exemplary equivalent bipole signal shapes and amplitudes.

[0023] FIG. 7 is a combined map showing activation propagation vectors and isochrones.

[0024] FIG. 9 is a diagrammatic view of helical basket catheter design with non-uniform electrode spacing along splines but uniform spacing over the ellipsoidal basket surface.

[0025] FIG. 10A is a diagrammatic view of a system for generating surface models and/or mapping electrophysiological information thereon.

[0026] FIG. 10B is simplified diagrammatic and schematic view of a model construction system of the system illustrated in FIG. 10A.

[0027] FIG. 11 is an electrical diagram of a switch box circuit configured to implement passive isolation at certain frequencies and short segments together at other frequencies.

[0028] FIGS. 12A and 12B are mapping system images illustrating the effectiveness of the switch box circuit before and during RF respectively.

[0029] FIG. 13 is a diagram of a set of cliques and the path integrals that can be determined from the cliques.

[0030] FIGS. 14A and 14B are diagrams of a determination of a mean conduction velocity vector field over an area.

[0031] FIG. 15 is a flowchart showing a step-by-step approach to identify uniform propagation, focal sources and rotors.

[0032] FIG. 16 is a table showing the characteristic values and shapes expected for determining tissue characteristics.

[0033] FIG. 17 is a diagram showing the activation pattern near a paddle catheter on a target tissue.

[0034] FIG. 18 is a diagram of a paddle catheter and the electrodes and rectangular cliques present on the paddle catheter.

[0035] FIG. 19 is a graph of the trajectory of vector E_z over a single beat.

[0036] FIG. 20A is a graph showing the EGM signals and equivalent bipole or omnipole E_a vs. time.

[0037] FIG. 20B is a line drawing of a shape of an exemplary E_a .

[0038] FIG. 21 is a graph showing the time interval that holds the most information about depolarizing tissue under a particular clique of electrodes.

[0039] FIG. 22 is a plot showing the weighting function vs. time.

[0040] FIG. 23 is a graph of an E-field loop showing regions of large and small $|d/dt(E(t))|$.

[0041] FIGS. 24A and 24B are graphs showing the tangent E-field loop before and after weighting the loop points based on the norm of the E-field.

[0042] FIGS. 25A and 25B are graphs showing the conduction velocity estimated from two cliques over successive beats.

[0043] FIG. 26 is a diagram of a saline tank test apparatus to simulate wavefront propagation.

[0044] FIG. 27 is a diagram of a paddle catheter in the saline tank test apparatus of FIG. 26.

[0045] FIG. 28 is a graph showing vector E_z and the activation direction over one saline tank test apparatus beat.

[0046] FIG. 29 is a graph showing $\dot{\phi}$ and E_a vs. time for two successive beats.

[0047] FIGS. 30A and 30B are diagrams of several of the possible types of cliques in a rectangular grid of electrodes and the associated scoring for the cliques.

[0048] FIG. 31 is a diagram of one embodiment of a scoring system for a corner clique.

[0049] FIG. 32 is diagram of a color triangle capable of associating a specific color to the set of scores for a clique.

[0050] FIG. 33 is a diagram of barycentric coordinates from normalized scores to govern the displayed color shown in FIG. 32.

[0051] FIG. 34 is a diagrammatic view of a system for generating surface models and/or mapping electrophysiological information thereon and determining a scoring system for a set of cliques.

DETAILED DESCRIPTION

[0052] Cardiac EP mapping today primarily uses bipolar electrograms (EGMs) obtained from electrode pairs. Bipoles are preferred as they have reduced low frequency noise, reduced far-field effects and often produce sharp and well-recognized features when filtered appropriately. Unipolar EGMs on the other hand contain far-field information and less stable baselines that make them less attractive for mapping purposes. A feature of the unipolar signal that makes it useful for mapping is the fact that its morphology and amplitude are independent of catheter orientation. Amplitudes and morphology of bipolar EGM's are dependent on the orientation of the electrode pair from which they are calculated and hence depend on the orientation of the catheter. The dependence on orientation results in inconsistently measured amplitudes and morphology-based measurements like activation times. It therefore also impacts derived quantities like scar boundaries, activation direction, and conduction velocity.

[0053] Electrophysiologic information may also be elicited by pacing a tissue or organ and observing the resulting spread of depolarization from immediately adjacent to the site where capture occurs. These observations are difficult with current technology because of pacing artifacts but directional information provided by E_m , E_a , or v , as described herein, can serve as clues to anatomic or functional conduction blocks. Even without pacing, conduction around obstacles such as valve orifices or blocks is known to become curved and slowed and this can be directly

mapped and visualized with the information disclosed herein much more conveniently and reliably than previously possible.

[0054] FIG. 1 depicts the variability in the morphology and amplitudes of a plurality of bipole signals **3** obtained from a catheter **7** in the right atrium of a heart. A plurality of unipolar signals **5** also acquired from the catheter **7** have very similar morphology and amplitudes but they are contaminated by far field ventricular depolarization.

[0055] One aspect described herein addresses a unique way to combine the benefit of orientation independence of the unipolar signals with the other benefits of bipolar signals that were highlighted previously. The disclosure utilizes closely spaced electrodes on high-density diagnostic catheters to derive local “pseudo bipolar”, “equivalent bipole”, or “omnipolar” signals that are orientation independent and are free of low-frequency noise and far-field effects. The closely spaced electrodes can be located on a single high-density diagnostic or other catheter or in some embodiments can be located on multiple catheters where electrodes on the catheters are located near or adjacent each other. Furthermore, the equivalent bipolar EGMs so derived possess characteristic shapes and relationships that reflect physiologic and anatomic directions which enable better contact maps by virtue of more consistent activation timing directions. The presence of closely spaced electrodes also helps to characterize the substrate in the immediate vicinity (few mm) of the catheter. The omnipolar electrogram signal’s amplitude and morphology would only be a function of the local substrate’s electrophysiology and hence lends itself to the creation of better, consistent, and more useful contact maps. Examples of high-density catheters that can be used for the purpose include (but are not limited to) the catheters shown in FIG. 2, and basket catheters like the catheters shown in FIG. 3 and FIG. 9.

[0056] FIGS. 2A-2C show embodiments of catheters that can be used for HD mapping applications. FIG. 2A illustrates one embodiment of a catheter **10** comprising a catheter body **11** coupled to a paddle **12**. The catheter body **11** can further comprise a first body electrode **13** and a second body electrode **14**. The paddle **12** can comprise a first spline **16**, a second spline **17**, a third spline **18**, and a fourth spline **19** that are coupled to the catheter body **11** by a proximal coupler **15** and coupled to each other by a distal connector **21** at a distal end of the paddle **22**. In one embodiment the first spline **16** and the fourth spline **19** can be one continuous segment and the second spline **17** and the third spline **18** can be another continuous segment. In other embodiments the various splines can be separate segments coupled to each other. The plurality of splines can further comprise a varying number of electrodes **20**. The electrodes in the illustrated embodiment can comprise ring electrodes evenly spaced along the splines. In other embodiments the electrodes can be evenly or unevenly spaced and the electrodes can comprise point or other types of electrodes. FIG. 2B illustrates another embodiment of a catheter **30** that can be used for HD mapping applications. The catheter **30** can comprise a catheter body **31** coupled to a paddle **32**. The catheter body **31** can further comprise a first body electrode **40** and a second body electrode **41**. The paddle **32** can comprise a first spline **34**, a second spline **35**, a third spline **36**, and a fourth spline **37** that are coupled to the catheter body **31** by a proximal coupler **33** and coupled to each other by a distal connector

38 at a distal end of the paddle **39**. In one embodiment, the proximal coupler **33** can further comprise an electrode.

[0057] Electrode placement along splines is controlled by the good mechanical stability of electrodes on splines. As a result, spacing along splines is best determined not by the mapping system, but by design and manufacturing. But spacing between splines is variable as a result of the forces and torques experienced as a catheter is maneuvered to a desired location. Electrodes located in spline midsections are most vulnerable to displacement. FIG. 2C shows incorporating slender tensile elements configured to join the splines near their centers to limit the maximal displacement from one another. One means to accomplish this is to use slender mono or multifilament nylon thread or suture like material, fastened at the ends, and looping around splines in the middle. A pass through a reflow oven during production allows the threads to become incorporated into the spline’s polymer insulation, securing the thread to each spline and minimizing protuberances.

[0058] FIG. 2C illustrates one embodiment of a catheter **100** using tethers to limit the maximal spread between splines and thus enforce a more consistent electrode spacing when in use. The catheter **100** can comprise a catheter body **101** coupled to a paddle **102**. The catheter body **101** can further comprise a first body electrode **103** and a second body electrode **104**. The paddle **102** can comprise a first spline **108**, a second spline **109**, a third spline **110**, and a fourth spline **111** that are coupled to the catheter body **101** by a proximal coupler **105** and coupled to each other by a distal connector **112** at a distal end of the paddle **114**. The paddle **102** can further comprise a first support member **106** and a second support member **107** to limit displacement of the splines from each other. These support members can be slender tensile elements (like threads or suture material) that collapse during insertion of the catheter **100** into a sheath. The catheters shown in FIGS. 2A, 2B, and 2C are further described in international application no. PCT/US2014/011, 940 filed 16 Jan. 2014 and published in English on 24 Jul. 2014 under international publication no. WO 2014/113612 (the ‘612 application) and U.S. provisional application No. 61/753,429, filed 16 Jan. 2013 (‘the ‘429 application). The ‘612 application and the ‘429 applications are both hereby incorporated by reference in their entirety as though fully set forth herein.

[0059] FIG. 3. Illustrates an embodiment of a basket catheter **50** which can be considered to be a 2D array of electrodes distributed over an ellipsoid surface. The basket catheter **50** can comprise a catheter body **51** coupled to a basket **52**. The basket **52** can be coupled to the catheter body with a proximal connector **53**. The basket **52** can comprise a plurality of splines **57**, a distal coupler **55**, and an irrigation tubing **56**. Each of the plurality of splines **57** can comprise at least one electrode **54**. In the illustrated embodiment, each of the plurality of splines comprises 8 electrodes. The exact number of electrodes can be varied based on the desired characteristics. The basket catheter shown in FIG. 3 is further described in U.S. provisional application No. 61/936, 677, filed 6 Feb. 2014, which is hereby incorporated by reference as though fully set forth herein

[0060] Current techniques to estimate conduction velocity and the direction of activation generally rely on robust determination of activation times over precise distances. The techniques to assign times to signal locations can result in predictions that are not accurate under certain conditions.

The method below utilizes the fundamental concept of wave propagation and does not rely on LAT (local activation time) detection algorithms. This approach is more robust and consistent. Certain extensions are also described that specialize and enhance the application to 2- and 3-dimensional arrangements of electrodes on cardiac surfaces. With each depolarization, the local electric field vector, E , sweeps out a loop like trajectory governed by anatomic and physiologic factors adjacent to these arrangements of electrodes. Two dimensional electrode arrangements allow the resolution of E_r , the “tangent bipole vector”, which is a useful orientation independent signal to which wave propagation principles can be applied and can be used to introduce a scalar version of E_r along the unit activation direction \hat{a} , and call it E_a . Three dimensional electrode arrangements allow the resolution of a component of E along the surface normal direction denoted \hat{n} called E_n . Finally, both 2- and 3-dimensional electrode arrangements allow determination of the E field along the direction $\hat{w}=\hat{n}\times\hat{a}$ called E_w , which for traveling waves is a very small signal.

[0061] FIG. 4 illustrates the unit activation vector **91**, wavefront vector **92**, surface normal vector **94**, wavefront crest **90**, and conduction velocity direction **93**. A single depolarization wavefront **90** is depicted based on a unipolar traveling wave voltage signal, $\phi(x,y,z,t)$. Propagation of the depolarization wavefront **90** occurs from left to right in the view. The depolarization wavefront **90** does not have to conform to a specific shape for the discussion within this disclosure to be valid, but a benefit can be found from physiologic unipolar morphology.

[0062] The orientation independent omnipole signals E_n and E_a possess characteristic shapes and amplitudes in normal myocardium. This can be further seen in FIGS. 6A-6C. These permit more robust determinations of EP characteristics such as electrogram amplitude, activation timing, and conduction velocity by traditional means.

[0063] The next section explains the derivation of the omnipole or “equivalent bipole” signal E_a using a high density catheter such as one of the catheters **10**, **30**, **50** shown in FIGS. 2-3. The paddle catheter, basket catheter, or other high density catheter is presumably maneuvered such that some or all adjacent electrodes lie flat on the surface/substrate. For convenience the following will use language indicating all catheter electrodes lie on the surface (i.e. the catheter lies on the surface) but the language refers to those electrodes that do lie on the surface or are sufficiently close to be indistinguishable from those that do.

[0064] The E-field (E) in the plane of the surface can be calculated using electrode locations X and the potentials measured at the electrodes ϕ using the following equations (where $d\phi$ and dX have been derived from X , ϕ , and subtraction matrix F , as described in international application no. PCT/US2014/037,160 filed 7 May 2014 and published in English on 13 Nov. 2014 under international publication no. WO 2014/182822 (the '822 application) and U.S. provisional application No. 61/855,058, filed 7 May 2013 (the '058 application). The '822 application and the '058 applications are both hereby incorporated by reference in their entirety as though fully set forth herein. The equations have the same form for both 2D and 3D situations:

$$d\phi=-(dX)^T E \quad (1)$$

$$E=-((dX)^{-T})^+ d\phi \quad (2)$$

where

[0065] ϕ —vector of unipolar potentials,

[0066] $d\phi$ —vector of bipolar potentials with respect to a common reference electrode,

[0067] X —matrix of mapping system coordinates for the electrodes,

[0068] dX —matrix of bipolar displacements with respect to the reference electrode location, and

[0069] A^- is the Moore-Penrose generalized inverse of matrix A .

[0070] FIG. 5. Illustrates one embodiment of a paddle catheter **70** showing 16 electrodes and some of the sets of electrodes that can be used to determine E_r . In the illustrated embodiment, the paddle catheter **70** can comprise four splines with each spline comprising four electrodes. Any 2D electrode set with at least three adjacent electrodes forms a clique and can be used for the calculations. A three electrode clique **71**, a four electrode clique **72**, and a five electrode clique **73** is illustrated on the paddle catheter **70** in FIG. 5. The three electrode clique **71** can comprise electrodes **D 75**, **two 76**, and **five 77**. The four electrode clique **72** can comprise electrodes **six 78**, **seven 79**, **ten 80**, and **eleven 81**. The five electrode clique **73** can comprise electrodes **six 78**, **nine 82**, **ten 80**, **eleven 81**, and **fourteen 83**. As can be seen by the above illustration, the same electrode on the catheter can be used for multiple cliques

[0071] The local E-field at a position on the surface can be calculated from sets of sufficient nearby electrodes (also referred to as a clique) on the catheter as illustrated in FIG. 5. As indicated generally by dashed lines in FIG. 5, for example, a 2-dimensional clique may comprise a set of three or more electrodes (e.g., electrodes **D**, **5**, **2**) located alone a plane of the catheter. When only a unipole or bipole is present the clique can be referred to as a degenerate clique. A degenerate clique is unable to be used to determine orientation independent assessments of directional quantities. A unipole degenerate clique, while orientation independent, has no real directional information. When, for example, more than 3 electrodes are used in a clique, the bipolar signals over-determine the 2D field. In such an instance, where the clique has more electrodes than strictly necessary for its 2D or 3D role, the clique is overdetermined and admits “subcliques.” Subcliques are themselves cliques which may or may not be minimal depending on how overdetermined the original clique was to start with and what subclique is being reviewed. Cliques that are not degenerate allow omnipoles and subcliques allow a unique direct demonstration of orientation independent sensing (OIS) superiority over traditional bipoles. OIS can be uniformly better than bipoles in determining many EP characteristics, including amplitude, timing, conduction velocity direction and magnitude. Although FIG. 5 only illustrates cliques comprising three (electrodes **D**, **5**, **2**) **71**, four (electrodes **6**, **10**, **11**, **7**) **72**, and 5 (electrodes **9**, **14**, **11**, **6**, **10**) **73** neighboring electrodes, the method can be extended to other cliques with more electrodes on the catheter. Since the catheter is assumed to lie flat on the substrate, the full 3D vector E at any clique is also expected to have components in the 2D tangent plane of the endocardial or epicardial surface. As a result, the term E_r is used to describe the component of the E-field in the tangent plane.

[0072] One method of determining the local E field is to choose one electrode from the clique as a reference electrode and determine $n-1$ bipolar potentials ($d\phi$) and displacements (dX) with respect to the reference electrode. Another method

of determining the local E field is to determine all possible distinct bipoles ($n*(n-1)/2$) from the clique's n electrodes to compute $d\phi$ and dX . Determining all possible distinct bipoles can lead to a more robust determination of the E-field as it reduces "2nd order" orientation effects that result from the electrode distribution with respect to wavefront.

[0073] Let \hat{a} and \hat{w} be unit vectors in the tangent plane along the activation and wavefront directions as illustrated in FIG. 4. For an ideal, homogenous wavefront, E_r is expected to be either parallel or anti-parallel to the activation direction (\hat{a}) with very little component along the wavefront direction (\hat{w}). The scalar E_a (also the equivalent bipole or omnipole activation signal) can be defined using the dot product as

$$E_a = E \cdot \hat{a} = E_r \cdot \hat{a} \quad (3)$$

E_a is the equivalent bipolar EGM that would be measured if one were to place a pair of bipoles separated by 1 mm along the activation direction. By definition, E_a is catheter and clique orientation independent and hence its morphology and amplitude should purely be a function of the local substrate. By virtue of it being a bipolar signal, it is also expected that it would be largely free of far-field artifacts and possess a stable isoelectric baseline.

[0074] FIGS. 6A-6C illustrate characteristic OIS omnipole signal shapes and amplitudes that permit more robust assessments of substrate including scar and activation timing maps. The two signals thus resolved (E_n and E_a) are significantly independent of each other, opening the possibility of learning more from local EGM signals. FIG. 6B illustrates an exemplary E_a signal and FIG. 6C illustrates an exemplary E_n signal. The algorithm to determine \hat{a} from E_r will be explained below.

[0075] The conduction velocity can be derived from the E-field using traveling wave concepts. The potential is recognized to be a function of space and time. Propagation of a traveling wave with velocity $v=(v_x, v_y, v_z)$ implies that the wave at time t_0 matches exactly the wave at a time t_0+t at coordinates $x+y_x t, y+y_y t,$ and $z+v_z t$. As a result

$$\Phi(x_0, y_0, z_0, t_0) = \Phi(x_0+v_x t, y_0+v_y t, z_0+v_z t, t_0+t) \quad (4)$$

for all initial times and locations t_0, x_0, y_0, z_0 and for all times t . Taking the total derivative of both sides of the above equation with respect to time leads to

$$0 = \frac{\partial \Phi}{\partial x} v_x + \frac{\partial \Phi}{\partial y} v_y + \frac{\partial \Phi}{\partial z} v_z + \frac{\partial \Phi}{\partial t}$$

which we note is equivalent to

$$0 = \nabla \Phi \cdot v + \dot{\Phi} \quad (5)$$

where v is a vector representing cardiac conduction velocity. Recognizing that $E = -\nabla \Phi$ and that only the component of E-field in the tangent plane contributes to the inner product, we get

$$E_r \cdot v = -\dot{\Phi} \quad (6)$$

$$E_a (\hat{a} \cdot v) = -\dot{\Phi} \quad (7)$$

The conduction velocity vector v can then expressed as

$$v = \frac{\dot{\Phi}}{E_a} \hat{a} \quad (8)$$

[0076] Conduction velocity, a presumed constant during depolarization, is recognized to be the ratio of the time derivative to the spatial derivative in the tangent plane of the potential. It is then expected that under ideal conditions, the morphology of E_a would be similar to that of $\dot{\Phi}$ with the only difference being a scale factor which would be the velocity magnitude. The activation direction (\hat{a}) is determined to be the direction in the tangent plane that results in the maximum correlation between $\dot{\Phi}$ and E_a . Although the expression above holds in principle at every time point, when signal levels are sufficiently small or isoelectric, the ratio of $\dot{\Phi}$ to E_a cannot be meaningfully determined.

[0077] The analysis can be expected to be more robust when the electrodes that form a clique are in good contact with the surface. This can be checked and enforced a priori using some or all of the criteria below. The criteria to check whether a clique is in good contact with the surface can be applied together or separately as determined by the user or process. Automatic application of the first six criteria can form an important component of the disclosure as getting uniform contact of all electrodes is generally difficult for any catheter, particularly so for small basket catheters.

[0078] The first criteria looks at the angular deviation between a 3D mapping systems determined surface normal near the clique and the normal to the plane that best fits the electrodes on the clique and determines whether they are below a threshold. The second criteria looks at the angular deviation between the normal corresponding to the clique of interest and the normal corresponding to the neighboring cliques and determines whether they are below a threshold. The third criteria looks at the distance between the electrode locations that form the clique and the surface and determines whether they are below a threshold. In one embodiment, the second criteria further includes ensuring that the local curvature is not above a threshold. The fourth criteria looks at the amplitudes of the unipolar signals obtained from the electrodes on the clique and determines whether they are within a typical range. The fifth criteria looks at the morphologies of the unipolar signals obtained from the electrodes on the clique and determines whether they are typical (e.g. modest upstroke followed by a dominant down deflection and fairly prompt return). The sixth criteria looks at the amplitudes, shapes, and morphologies of E_t and E_a obtained from the clique and determines whether they are typical. The seventh criteria looks at the visual cues for good contact such as fluoro, ICE, etc. as well as tactile sensations and maneuvering history on the part of a catheter operator. While seven criteria are listed herein to check whether a clique is in good contact with the surface, not all seven of the criteria listed have to be used to make that determination. Further, other criteria can also be used to determine whether a clique has made good contact with a surface.

[0079] Conduction velocity once derived can be displayed with a 3D mapping system on the chamber geometry using, for example, arrows, with the direction of the arrow indicating the activation direction and the color, length, or width of the arrow showing the magnitude. In another embodiment an interpolated color map can also be used to display conduction velocity magnitude with or without arrows of

uniform length showing the direction. FIG. 7, as discussed below, illustrates another embodiment where conduction velocity vector maps can also be coupled with LAT maps. Generally, the display is updated immediately following each local depolarization and persisting or gradually fading out until the next local depolarization. Finally, some or all isochrones may be displayed as curved lines on the cardiac surface, for instance at specific intervals since the start of depolarization such as 0, 20, 40, and 60 ms. This reduces visual clutter and allows a more interpretable superposition of conduction velocity arrows.

[0080] FIG. 7. Illustrates a combined map showing a catheter **98**, a plurality of electrodes **99**, a plurality of activation propagation vectors **95** and isochrones. The activation propagation vectors **95** can be of constant length and color coded to indicate the magnitude of velocity. Alternatively, the length or the size of the vectors can also be used to indicate the magnitude of velocity. The vectors **95** can also be superimposed on color maps **97** of conduction velocity magnitudes, activation time, amplitude, or any of a variety of other indices of cardiac function. The gradient lines **96** can be used to shown conduction velocity magnitudes with various colors representing different velocities. Maps showing conduction velocities with color gradients are well known in the art and used in many different systems.

[0081] As can be readily appreciated from equations 1 and 2 listed above, it is important to have reasonably accurate electrode displacements (dX) and electrode positions (X) to judge contact and the local surface tangent plane so as to portray the signals and resulting EP characteristics including conduction velocity accurately. It has been suggested that impedance based mapping system locations are more robustly determined from tip or circumferential ring electrodes than from small surface area electrodes on portions of a catheter shaft. Nevertheless, the issue can remain significant in catheter designs with small ring electrodes on flexible splines. Small electrodes, owing to their high electrode-electrolyte impedance can be difficult to locate accurately—they are more susceptible to artifact and can be biased toward the system reference “belly patch” electrode. Compensation algorithms can be used to correct for the positions, however, they rely on a priori knowledge of the construction and inter-electrode distances. Flexible splines can deform, bunch up, or become separated (splayed) in vivo under certain conditions resulting in important deviations from their nominal design. When that happens, the compensation algorithms referred to above may not be able to effectively correct electrode location errors. Means to prevent the deformations, bunching, and separation of catheter splines and electrodes from becoming severe enough to significantly disturb assessments of EP characteristics are also disclosed above in relation to FIG. 2C.

[0082] FIG. 8 illustrates a flowchart showing a step-by-step approach to acquire, determine, and output orientation independent information. The method illustrated in the flowchart can comprise the following steps:

[0083] At step **130** acquire electrophysiology signals from a plurality of electrodes.

[0084] At step **132** determine the location of the plurality of electrodes in step **130**.

[0085] At step **134** determine whether the plurality of electrodes are on or near the target surface.

[0086] At step **136** form cliques from the electrodes that fit within defined characteristics for inclusion in cliques.

[0087] At step **138** process the electrophysiology signals to determine E_n , E_a , E_r , conduction velocity, and other orientation independent characteristics such as amplitude or timing.

[0088] At step **140** output the derived information to a display.

[0089] Helical basket catheters have been proposed as a means to achieve more uniform coverage of electrodes over the extent of a basket. This can be a desirable characteristic for this disclosure on its own, but also for the increased stiffness (and thus resistance to displacement) that results. Increased stiffness can allow for reliance on the spacing as determined by design and manufacturing rather than the mapping system location for each electrode.

[0090] FIG. 9 illustrates a helical catheter design of a catheter **120** with non-uniform electrode spacing along splines but achieves a nearly uniform electrode dispersal over the outer surface of the basket. Each point **121** in the figure represents an electrode. The catheter illustrated in FIG. 9 is further described in U.S. application Ser. No. 13/790,110, filed 8 Mar. 2014, which is hereby incorporated by reference as though fully set forth herein.

[0091] The local nature of determinations made by beam buckling theory suggests compliance goes as the length dimension squared so twice as small translates to 4 times stiffer. With small size, then, come the benefits of: (a) interelectrode spacing more consistent under varying use conditions, (b) more dense sampling and thus better spatial resolution, and (c) the capacity to be maneuvered into full contact positions and orientations.

[0092] As discussed earlier, conventional mapping techniques suffer from bipole orientation induced amplitude and morphology uncertainty which also adversely affects activation timing. Challenging arrhythmias in clinical EP today may involve features such as channels with low amplitudes and slow conduction that are only of the order of 5 mm in width. Detailed maps are often not required over an entire cardiac chamber but confined to certain locations where pathology often appears or other diagnostic tests such as surface ECGs, ultrasound, MRI, or even basic EP catheter signals indicate. What is important is that the information reliably reflect the state of the myocardium locally and that it do so with adequate resolution.

[0093] The algorithm discussed in the invention can be used to derive local E-fields (including E and E_r), and equivalent bipolar signals (E_n and E_a) with orientation independent amplitudes and reliable morphology/timing, and instantaneous conduction velocity vectors. We postulate such characterization will permit improved maps of substrate amplitude (using E_n , E_a , or measures of E field loop size), activation times (LAT), conduction velocity (magnitude and direction), as well as a novel index of inhomogeneous conduction derived from E_n or the eccentricity of E_r . Bipolar-like omnipole signals of consistent morphology may be understood from the fundamentals of cell depolarization and unipolar EGM signals when in proximity to active tissue.

[0094] One or more of these characteristics can also enable clinicians to perform more reliable scar border delineation (known to contribute to VT and other arrhythmias). Also, local determinations of low amplitude and/or slow conduction velocity can help identify critical pathways such as isthmuses for arrhythmias that are amenable to ablation therapy. More reliable EGM amplitudes and morphologies

can also allow better measures of EGM reduction measures, lesion characterization, or the local assessment of conduction velocity as a critical isthmus is affected or a lesion gap approached.

[0095] OIS technology can also be utilized with implanted medical devices. Implanted medical devices responsible for rhythm discrimination currently rely primarily on depolarization event timing. Timing alone however can fail to distinguish between important rhythms as the times of occurrence can be similar, and multi-chamber algorithms are not sufficiently specific. The application of OIS to an implanted device's catheter or lead can establish a baseline direction and speed (using OIS characterizations) for healthy rhythms.

[0096] Implanted devices already perform elementary mapping system functions, but with OIS technology as discussed herein, can better track the number and degree of abnormality of beats and can group them by similarity in detection criteria. For example, a non-physiologic heart rate increase typically would cause the conduction velocity to decrease, while a physiologic cause for heart rate increase, like exercise, would not result in a decrease in conduction velocity. Hence the decision to treat this tachycardia can be based not only on changes in heart rate and other traditional ICD metrics such as timing but based on noting the conduction velocity vector's direction and magnitude are consistent with a VT. Some of the detection criteria that can be used by the implanted device can include combinations of rate, number consecutive abnormal beats, frequency "x of y beats", etc.

[0097] Observations from one or more sites on implanted leads can also be used to track rate or ischemia induced functional block occurrences with greater accuracy than inferences drawn from timing changes. This in turn can enable patient or health care provider alerts to potential problems with brady or tachy arrhythmias before deciding on treatments with pacing or cardioversion shocks.

[0098] This technology is also valuable when applied at the time of RF ablation. Although OIS omnipole compatible electrode arrays today are seldom invoked as ablation electrodes, they may prove valuable in the future, particularly when combined with the resolution and consistency of the mapping capabilities described elsewhere in this disclosure. RF may be delivered through individual electrodes of such an array in the standard fashion. If, however, RF is to be delivered simultaneously through a number of adjacent electrodes so as to create a line of block or a single conjoined lesion, it is valuable to do so in a manner that maintains individual EGM signals and mapping system positions but effectively delivers RF voltage in parallel to emulate a single large electrode.

[0099] A passive circuit technique is disclosed for achieving a similar result. The passive circuit was used with an ablation catheter having a split tip that effectively deployed a 4 electrode 2D array at its tip. Capacitors served as low impedance elements to couple RF from a single generator connection at relatively high RF frequencies and serve as high impedance connections between electrodes at the lower frequencies of impedance mapping system and EGM amplifiers. Several embodiments of catheters fitting this description are further described in international application no. PCT/US2014/011,940 filed 16 Jan. 2014 and published in English on 24 Jul. 2014 under international publication no. WO 2014/113612, which is hereby incorporated by refer-

ence as though fully set forth herein. For the catheter design used herein, the circuit employed 33 nF capacitors though values between 10-100 nF would also work.

[0100] FIG. 10A illustrates one embodiment of a system **160** for mapping electrophysiological information corresponding to an anatomic structure onto a multi-dimensional (e.g., three-dimensional) geometry surface model of the anatomic structure (each of the terms "electrophysiology" and "electrophysiological" will hereinafter be referred to as "EP"). The system **160** comprises, among other components, a medical device **162** and a model construction system **164**. In one embodiment, the medical device **162** comprises a catheter, and the model construction system **164** comprises, in part, a processing apparatus **166**. The processing apparatus **166** may take the form of an electronic control unit, for example, that is configured to obtain a geometry surface model of the cardiac structure, and to construct an EP map corresponding to the cardiac structure using data collected by, for example, the catheter **162**. The catheter **162** is configured to be inserted into a patient's body **168**, and more particularly, into the patient's heart **170**. The catheter **162** may include a cable connector or interface **172**, a handle **174**, a shaft **176** having a proximal end **178** and a distal end **180** and one or more sensors **182** (e.g., **1821**, **1822**, **1823**) mounted in or on the shaft **176** of the catheter **162**. In one embodiment, the sensors **182** are disposed at or near the distal end **180** of the shaft **176**. The connector **172** provides mechanical, fluid, and electrical connection(s) for cables, such as, for example, cables **184**, **186** extending to the model construction system **164** and/or other components of the system **160** (e.g., a visualization, navigation, and/or mapping system (if separate and distinct from the model construction system **164**), an ablation generator, irrigation source, etc.).

[0101] The sensors **182** mounted in or on the shaft **176** of the catheter **162** are electrically connected to the model construction system **164**, and the processing apparatus **166** thereof, in particular. The sensors **182** may be provided for a variety of diagnostic and therapeutic purposes including, for example and without limitation, EP studies, pacing, cardiac mapping, and ablation. In an embodiment, one or more of the sensors **182** are provided to perform a location or position sensing function. Accordingly, in such an embodiment, as the catheter **162** is moved along a surface of the cardiac structure and/or about the interior thereof, the sensor(s) **182** can be used to collect location data points that correspond to the surface of, or locations within, the cardiac structure. These location data points can then be used by, for example, the model construction system **164** in the construction of a geometry surface model of the cardiac structure.

[0102] In one embodiment, the model construction system **164**, and the processing apparatus **166** thereof, in particular, is configured to obtain a geometry surface model of the cardiac surface (or at least a portion thereof), and to map EP information corresponding to that cardiac structure onto the geometry surface model. The processing apparatus **166** is configured to use, at least in part, data (location data and/or EP data/information) collected by the catheter **162** in the construction of one or both of a geometry surface model and an EP map.

[0103] In an embodiment wherein the model construction system **164** is configured to construct the geometry surface model, the model construction system **164** is configured to acquire location data points collected by the sensor(s) **182**

corresponding to the cardiac structure. The model construction system **164** is configured to then use those location data points in the construction of the geometry surface model of the cardiac structure. The model construction system **164** is configured to construct a geometry surface model based on some or all of the collected location data points. In addition to constructing a geometry surface model of a structure, the model construction system **164** is configured to function with the sensor(s) **182** to collect location data points that are used in the construction of the geometry surface model. In such an embodiment, the model construction system **164** may comprise an electric field-based system, such as, for example, the EnSite NavX™ system commercially available from St. Jude Medical, Inc., and generally shown with reference to U.S. Pat. No. 7,263,397 entitled “Method and Apparatus for Catheter Navigation and Location and Mapping in the Heart”, the entire disclosure of which is incorporated herein by reference. In other exemplary embodiments, however, the model construction system **164** may comprise other types of systems, such as, for example and without limitation: a magnetic-field based system such as the Carto™ System available from Biosense Webster, and as generally shown with reference to one or more of U.S. Pat. No. 6,498,944 entitled “Intrabody Measurement,” U.S. Pat. No. 6,788,967 entitled “Medical Diagnosis, Treatment and Imaging Systems,” and U.S. Pat. No. 6,690,963 entitled “System and Method for Determining the Location and Orientation of an Invasive Medical Instrument,” the entire disclosures of which are incorporated herein by reference, or the gMPS system from MediGuide Ltd., and as generally shown with reference to one or more of U.S. Pat. No. 6,233,476 entitled “Medical Positioning System,” U.S. Pat. No. 7,197,354 entitled “System for Determining the Position and Orientation of a Catheter,” and U.S. Pat. No. 7,386,339 entitled “Medical Imaging and Navigation System,” the entire disclosures of which are incorporated herein by reference; a combination electric field-based and magnetic field-based system such as the Carto 3™ System also available from Biosense Webster.

[0104] In one embodiment, the sensor(s) **182** of the catheter **162** comprise positioning sensors. The sensor(s) **182** produce signals indicative of catheter location (position and/or orientation) information. In an embodiment wherein the model construction system **164** is an electric field-based system, the sensor(s) **182** may comprise one or more electrodes. In such an embodiment, each of the electrodes may comprise one of a number of types of electrodes, such as, for example, tip electrodes, ring electrodes, button electrodes, coil electrodes, brush electrodes, flexible polymer electrodes, and spot electrodes. Alternatively, in an embodiment wherein the model construction system **164** is a magnetic field-based system, the sensor(s) **182** may comprise one or more magnetic sensors configured to detect one or more characteristics of a low-strength magnetic field. For instance, in one exemplary embodiment, the sensor(s) **182** may comprise magnetic coils disposed on or in the shaft **176** of the catheter **162**.

[0105] For purposes of clarity and illustration, the model construction system **164** will hereinafter be described as comprising an electric field-based system, such as, for example, the EnSite NavX™ system identified above. It will be appreciated that while the description below is primarily limited to an embodiment wherein the sensor(s) **182** comprise one or more electrodes, in other exemplary embodi-

ments, the sensor(s) **182** may comprise one or more magnetic field sensors (e.g., coils). Accordingly, model construction systems that include positioning sensor(s) other than the sensors or electrodes described below remain within the spirit and scope of the present disclosure.

[0106] In one embodiment, the system **160** can further comprise a circuit box **195**. The circuit box can be used as further described in FIG. **11** to implement passive isolation at EGM and impedance mapping system frequencies, and yet effectively short segments together at ablation frequencies.

[0107] With reference to FIG. **10B**, in addition to the processing apparatus **166**, the model construction system **164** may include, among other possible components, a plurality of patch electrodes **188**, a multiplex switch **190**, a signal generator **192**, and a display device **194**. In another exemplary embodiment, some or all of these components are separate and distinct from the model construction system **164** but that are electrically connected to, and configured for communication with, the model construction system **164**.

[0108] The processing apparatus **166** may comprise a programmable microprocessor or microcontroller, or may comprise an application specific integrated circuit (ASIC). The processing apparatus **166** may include a central processing unit (CPU) and an input/output (I/O) interface through which the processing apparatus **166** may receive a plurality of input signals including, for example, signals generated by patch electrodes **188** and the sensor(s) **182**, and generate a plurality of output signals including, for example, those used to control and/or provide data to, for example, the display device **194** and the switch **190**. The processing apparatus **166** may be configured to perform various functions, such as those described in greater detail above and below, with appropriate programming instructions or code (i.e., software). Accordingly, the processing apparatus **166** is programmed with one or more computer programs encoded on a computer storage medium for performing the functionality described herein.

[0109] With the exception of the patch electrode **188B** called a “belly patch,” the patch electrodes **188** are provided to generate electrical signals used, for example, in determining the position and orientation of the catheter **162**. In one embodiment, the patch electrodes **188** are placed orthogonally on the surface of the body **168** and are used to create axes-specific electric fields within the body **168**.

[0110] In one embodiment, the sensor(s) **182** of the catheter **162** are electrically coupled to the processing apparatus **166** and are configured to serve a position sensing function. More particularly, the sensor(s) **182** are placed within electric fields created in the body **168** (e.g., within the heart) by exciting the patch electrodes **188**. For purposes of clarity and illustration only, the description below will be limited to an embodiment wherein a single sensor **182** is placed within the electric fields. It will be appreciated, however, that in other exemplary embodiments that remain within the spirit and scope of the present disclosure, a plurality of sensors **182** can be placed within the electric fields and then positions and orientations of each sensor can be determined using the techniques described below.

[0111] When disposed within the electric fields, the sensor **182** experiences voltages that are dependent on the location between the patch electrodes **188** and the position of the sensor **182** relative to tissue. Voltage measurement comparisons made between the sensor **182** and the patch electrodes

188 can be used to determine the location of the sensor **182** relative to the tissue. Accordingly, as the catheter **162** is swept about or along a particular area or surface of interest, the processing apparatus **166** receives signals (location information) from the sensor **182** reflecting changes in voltage levels on the sensor **182** and from the non-energized patch electrodes **188**. Using various known algorithms, the processing apparatus **166** may then determine the location (position and orientation) of the sensor **182** and record it as a location data point corresponding to a location of the sensor **182** on the surface of, or within, the cardiac structure in a memory or storage device associated with, or accessible, by the processing apparatus **166**, such as the memory **197**. In one embodiment, prior to recording the location as a location data point, the raw location data represented by the signals received by the processing apparatus **166** may be corrected by the processing apparatus **166** to account for respiration, cardiac activity, and other artifacts using known or hereafter developed techniques. The system described in FIGS. **10A** and **10B** is further described in U.S. application Ser. No. 14/533,630, filed 5 Nov. 2014, which is hereby incorporated by reference as though fully set forth herein.

[**0112**] FIG. **11** depicts a switch box circuit **200** configured interface an OIS compatible ablation catheter to an RF generator and a 3D mapping system. The circuit implements passive isolation at EGM and impedance mapping system frequencies, and yet effectively short segments together at ablation frequencies. The switch box circuit **200** The switches allow for convenient alternation between truly shorting the tip electrodes together (at all frequencies) and shorting them together for only ablation. The switch box circuit **200** introduces a practical means to treat a “split tip” ablation catheter design as a single common electrode for purposes of RF ablation and yet distinct electrodes for NavX and EGM signals. The switch box circuit **200** can be coupled to a catheter through a catheter connector **201**. The catheter connector **201** can comprise a plurality of catheter pins and can be coupled to a catheter. Each of the catheter pins can be electrically connected to various sensors or electrodes on the catheter. In the illustrated embodiment a fourth catheter pin **202** can be connected to a third tip segment. A fifth catheter pin **203** can be connected to a fourth tip segment. A sixth catheter pin **204** can be connected to a first tip segment. A seventh catheter pin **205** can be connected to a proximal ring electrode on the catheter body. An eighth catheter pin **206** can be connected to a center ring electrode on the catheter body. A ninth catheter pin **207** can be connected to a distal ring electrode on the catheter body. A tenth catheter pin **208** can be connected to a second tip segment. An eleventh catheter pin **209** can be connected to a first thermocouple lead. A fourteenth catheter pin **210** can be connected to a second thermocouple lead.

[**0113**] The switch box circuit **200** can further be coupled to an ablation generator through an ablation generator connector **215**. The ablation generator connector **215** can comprise a plurality of generator pins and can be coupled to an ablation generator. A first generator pin **216** can be coupled to a first thermocouple lead. A second generator pin **217** can be coupled to a second thermocouple lead. An eleventh generator pin **218** can be coupled to a proximal ring electrode of the catheter body. A twelfth generator pin **219** can be coupled to a center ring electrode of the catheter body. A thirteenth generator pin **220** can be coupled to a distal ring electrode of the catheter body. A fourteenth generator pin

221 can be coupled to a combined tip electrode of the catheter. The switch box circuit **200** can further be coupled to a breakout cable through a breakout cable connector **225**. The breakout cable can be coupled to a breakout cable connector **225** that can comprise a plurality of breakout pins. A first breakout pin can be coupled to a first tip segment. A second breakout pin can be coupled to a second tip segment. A third breakout pin can be coupled to a third tip segment. A fourth breakout pin can be coupled to a fourth tip segment. A fifth breakout pin can be coupled to a distal ring electrode of the catheter body. A sixth breakout pin can be coupled to a center ring electrode of the catheter body. A seventh breakout pin can be coupled to a proximal ring electrode of the catheter body.

[**0114**] The switch circuit box **200** can further comprise a plurality of switches. Each of a plurality of tip segment electrodes can be electrically coupled to an RF ablation generator by two switches and a capacitor. The illustrated embodiment of the switch circuit box **200** can be configured to couple a catheter with four segmented tip electrodes and at least one thermocouple to an ablation generator and a mapping system. In the illustrated embodiment, the switch box circuit **200** can be coupled to a catheter comprising four segmented tip electrodes. The first tip segment can be electrically coupled to a first switch **230**, a second switch **231**, and a first capacitor **232**. The second tip segment can be electrically coupled to a third switch **234**, a fourth switch **235**, and a second capacitor **236**. The third tip segment can be electrically coupled to a fifth switch **238**, a sixth switch **239**, and a third capacitor **240**. The fourth tip segment can be electrically coupled to a seventh switch **242**, an eighth switch **243**, and a fourth capacitor **244**.

[**0115**] The first, third, fifth, and seventh switches can be referred to as a first set of switches in the switch circuit box **200**. The second, fourth, sixth, and eighth switches can be referred to as a second set of switches in the switch circuit box **200**. The first set of switches can be configured to disconnect the plurality of tip segment electrodes from an ablation generator. In the illustrated embodiment, the plurality of tip segment electrodes can comprise four tip segment electrodes, each of which is connected to a switch in the first set of switches. The second set of switches can be configured to have the plurality of tip segment electrodes appear to the ablation generator as if they are a direct short. The second set of switches can further be configured to allow the plurality of tip segment electrodes to appear as a single capacitively coupled blend electrode. As a result of the first set of switches and the second set of switches the switch circuit box **200** can allow for an ablation generator to see the plurality of tip segment electrodes as one tip electrode and emit energy accordingly, while at the same time allow a mapping system to see the plurality of tip segment electrodes as independent electrodes. In another embodiment, The RF generator sees no tip electrode when the first set of switches is in a first state, and a blend of the 4 tip segments as decided by the capacitors **232**, **236**, **240**, **244** and the first set of switches in a second state. When the second set of switches are in a first state the 4 split tip electrodes are directly shorted together. When the second set of switches are in a second state, the 4 split tip electrodes are effectively combined for RF but distinct for mapping systems and electrograms. The visualization of the electrode can be seen in FIGS. **12A** and **12B**.

[0116] The switch circuit box 200 can further comprise a distinct thermocouple 250. The circuit box's distinct thermocouple 250 can be electrically coupled to a first thermocouple switch 251 and a second thermocouple switch 252. When the first thermocouple switch 251 and the second thermocouple switch 252 are in the up position, a signal from the circuit box's distinct thermocouple 250 can be transmitted to the ablation generator. When the first thermocouple switch 251 and the second thermocouple switch 252 are in the down position, a signal from the catheter thermocouple can be transmitted to the ablation generator.

[0117] FIGS. 12A and 12B illustrate the passive circuit described in FIG. 11 in use with a mapping system as described herein. The effectiveness of the passive circuit approach described in this disclosure can be seen for an ablation catheter with four tip electrodes. The common capacitively coupled connection that is intended for only ablation, when shown as a rendered ablation catheter 290 in an impedance mapping system shows up as a tip electrode at the center of a 2D planar array of a rendered split tip catheter 292. While two separate catheters, the rendered ablation catheter 290 and the rendered split tip catheter 292, are both displayed in the mapping system, these two catheters comprise a single catheter and the switch box circuit can allow for them to be displayed as two. As seen in FIG. 12B, the rendered ablation catheter 290 is disposed within the 2D planar array of the rendered split tip catheter 292. The impedance mapping system shows the capacitively coupled connection and split tip electrode as separate catheters sharing the same general space in locations proximal of the split tip. The three proximal ring electrodes are handled conventionally and thus co-locate for the rendered ablation catheter 290 and the split tip catheter 292. The figure further comprises a circular mapping catheter and a reference catheter. FIGS. 12A and 12B show that there is no change in appearance in the impedance mapping system or electrogram signals before and during RF ablation when using the four capacitively coupled split tip electrodes as a single RF tip electrode. FIG. 12A depicts the impedance mapping system at 1 second before RF ablation, and FIG. 12B depicts the impedance mapping system at 2 seconds after RF ablation.

[0118] Methods to identify focal sources and rotors using the signals derived in the previous sections are next disclosed. Two approaches to identify this information will be presented. The first approach is most general and relies on triangular cliques. The second approach is specific to the rectangular cliques of a paddle catheter as previously discussed. The propagation of a wavefront from a focal source is typically slow near the source and speeds up as it propagates through the rest of the myocardium. In one embodiment, focal source candidates are identified by locating regions with low conduction velocity using conduction velocity maps. In another embodiment, the region with minimum conduction velocity can be identified to be the location of focal sources. This can be done without mapping the entire chamber, by choosing successive locations in the direction opposite to "outbound" conduction velocity. A chain of velocity vectors traces a path to the focal source in a step by step process, avoiding a need to map most of or the entire chamber and thus saving time. Alternatively, gradients of the velocity magnitudes ($v=|v|$) calculated from multiple cliques in a single acquisition can also be used to direct the user towards the region of minimum conduction velocity.

[0119] Convex (outward) propagation vectors are associated with lower conduction velocities. This is a result of each depolarized cell having to activate by gap junctions more cells ahead of it in a manner dependent on the curvature. Pacing near threshold can, depending on both the size and amplitude of the pacing stimulus as well as local preferential pathways or anisotropic (directionally dependent) conduction result in a symmetric or asymmetric pattern which the arrays of this invention disclosure are well suited to identify.

[0120] Regions with focal activity and rotors can also be identified by approximating surface and closed path integrals of velocities derived at a set of neighboring cliques. Electrodes on a catheter can form 3 or more electrode cliques. About an interior common electrode, a closed path can be considered to pass through the centroid of each clique. This is illustrated in FIG. 13. The cliques enclosed by this path form a surface. Conduction velocity distributions on such surfaces and closed paths lend themselves to approximations of divergence and curl vector operations through Stokes Theorem and the Divergence or Gauss Theorem.

[0121] FIG. 13 shows the surface points corresponding to electrode locations and a plurality of cliques 300 formed using an electrode triplet. The points 302 represent the surface electrode locations and the dots 304 correspond to the centroid of the cliques 300. The path integrals 306 are evaluated along the lines that connect the centroids 304 of the cliques 300. Adjacent electrode groups, shown here as triangle cliques, provide local conduction velocities. This process enables a mapping system to compute indices of strong uniform propagation, rotation (rotors), and source/sink and can permit automated classification of field of view.

[0122] An angle dependent assessment of conduction velocity can be conceptually defined in a neighborhood about a point to be

$$p(\theta) = \iint_A v(A) \cdot t(\theta) dA / \iint_A dA \quad (9)$$

where A is the small region over which the surface integral is calculated (typically would span the area covered by a set of neighboring cliques). $t(\theta)$ is a unit vector oriented at an angle θ with respect to an arbitrary axis. Normalized or weighted by area, the maximum of $p(\theta)$, P, is the mean velocity directed at angle θ , and thus forms the mean velocity vector of area A. In practice, an integral over area A may be discretely approximated by the sum over the cliques that compose A and the velocity at each point in A, $v(A)$, approximated as piecewise constant in each clique. To summarize, uniform propagation is characterized by a highly eccentric $p(\theta)$ whose maximal value P is in the physiologic range of conduction velocities, roughly $0.3 < P < 1.4$ mm/ms.

[0123] FIGS. 14A and 14B illustrate the determination of an approximately uniform conduction velocity vector field over area A 310 and the determination of mean velocity vector 315. As unit direction vector $\hat{u}(\theta)$ is rotated through 360 degrees, $p(\theta)$ traces out an ellipse with its maximum direction 315 aligned along a major axis.

$$P = \max_{\theta} \left\{ p(\theta) = \frac{\sum_i v_i \cdot \hat{u}(\theta) \cdot A_i}{\sum_i A_i} \right\}$$

[0124] Once uniform conduction has been judged unlikely, the velocity vector field may be processed for evidence of rotational or focal source activity. Using Stoke's theorem and Gauss' theorem, the curl and divergence of the velocity field can be calculated using path integrals as follows

$$\iint_A (\nabla \times v) \cdot dA = \oint_S v \cdot ds \text{ curl} \quad (10)$$

$$\iint_A (\nabla \cdot v) dA = \oint_S v \cdot \hat{n} \text{ ds div} \quad (11)$$

[0125] A path integral around closed path S which contains area A **310** may be discretely approximated as a sum over the line segments that join clique centroids (e.g. the lines **306** of FIG. **13**) or the exterior path consisting of all outer segments of area A **310**. As we did for uniform propagation, it is convenient to normalize the results into a signed mean rotational velocity vector magnitude and signed mean outward pointing velocity vector magnitude so as to not depend on clique or area A's size and better discern true rotational or outer/inner propagation from random results in scar tissue.

[0126] Let x_i denote the coordinates of the i^{th} clique's centroid for cliques that form the outer boundary of area A. Also let v_i be the velocity vector associated with that clique. Then define the "average path vector" between centroid points $i-1$ and $i+1$ to be

$$\delta_i = \frac{(x_{i+1} - x_i) + (x_i - x_{i-1})}{2} = \frac{(x_{i+1} - x_{i-1})}{2}$$

where the indices wrap appropriately around the closed path for area A. Then the path length weighted curl of the velocity vector field may be defined to be

$$C := \sum_i \delta_i \cdot v_i / \sum_i |\delta_i|$$

[0127] The path length weighted divergence (D) may be similarly defined by introducing a 90 degree rotated, outward pointing, version of δ_i denoted as ∂_i so that

$$D := \sum_i \partial_i \cdot v_i / \sum_i |\partial_i|$$

where

$$\partial_i = \frac{\|x_{i+1} - x_i\| \hat{m}_{i+1,i} + \|x_i - x_{i-1}\| \hat{m}_{i,i-1}}{2}$$

[0128] The curl of the velocity field (C) would provide a strong indication of the presence of rotors while the divergence of the velocity field (D) would provide a strong indication of focal source or collision site. The sign of the divergence can then be used to distinguish a focal source location from a collision site. Since ∂_i was defined to be an outward pointing normal then the path integral would be positive for a focal source and negative for a collision site.

[0129] Derived quantities C and D can be displayed on the 3D geometry using a mapping system. Color maps of C and D can be used to locate regions of high and low curl and divergence indicating potential existence of rotors, focal sources or collision sites.

[0130] FIG. **15** illustrates a flowchart showing a step-by-step approach to identify focal sources and rotors using path and surface integrals of local conduction velocity determinations. This classification algorithm depends on reasonably correct velocity vector determinations not confused by

double potentials, should they exist. The result enables automatic rhythm classification of uniform propagation, rotor, scar, focus, and collision sites. The method illustrated in the flowchart can comprise the following steps:

[0131] At step **350**, compute the local velocity vectors from a collection of adjacent electrode cliques or non-contact mapping virtual positions.

[0132] At step **351**, calculate the angular dependence of flow field $p(\theta)$.

[0133] At step **352**, determine whether a large major axis is present and whether there is strong eccentricity.

[0134] If there is a large major axis and strong eccentricity proceed to step **353**. At step **353**, uniform propagation has been established and the mean direction and velocity of the collection of adjacent electrode cliques can be shown.

[0135] If there is not a large major axis and strong eccentricity proceed to step **354**. At step **354**, compute the Divergence and Curl path integrals and the path length.

[0136] At step **355**, determine whether the curl rotation is large from a sufficiently large positive or negative value of C corresponding to a counterclockwise or clockwise rotation.

[0137] If the curl rotation is large proceed to step **356**. At step **356**, it is determined that there is a probable rotor at the location where the collection of adjacent electrode cliques was taken and the direction of the rotor can be shown.

[0138] If the curl rotation is not large proceed to step **357**. At step **357**, determine whether the divergence in/out flow is large from large positive or negative values of D respectively.

[0139] If the divergence in/out flow is not large proceed to step **358**. At step **358**, it is determined that there is probable scar at the location where the collection of adjacent electrode cliques was taken.

[0140] If the divergence in/out flow is large proceed to step **359**. At step **359**, determine whether the div flow is outward.

[0141] If the divergence flow is outward or positive proceed to step **360**. At step **360**, it is determined that a probable focus or focus driver is present at the location where the collection of adjacent electrode cliques was taken.

[0142] If the divergence flow is not outward proceed to step **361**. At step **361**, it is determined that a probable collision site is present at the location where the collection of adjacent electrode cliques was taken.

[0143] FIG. **16** depicts a table showing P (propagation), C (curl), and D (divergence) of velocity and their characteristic values and shapes expected for uniform wavefront propagation, rotors, focal sources and collision sites. The table shows that a uniform propagation **370** is suggested when propagation is strong and eccentric, the curl is small, and the divergence is small. A rotor **371** is suggested when propagation is weak, the curl is large, and the divergence is small. A focal source **372** is suggested when the propagation is weak, the curl is small, and the divergence is large and positive. A collision site **373** is suggested when the propagation is weak, the curls is small, and the divergence is large and negative. A scar **374** is suggested when the propagation is weak, the curl is small, and the divergence is small.

[0144] A recorded segment and time when the paddle catheter was placed along the septal wall of the right atrium was located and signals studied to estimate the parameters discussed in the previous section. FIG. **17** depicts two views of a combined map showing a paddle catheter comprising a

plurality of electrodes **385**, and the location of the paddle catheter in the right atrium on a septal wall. The paddle catheter is situated against a surface of a fossa ovalis in the right atrium. The combined map further shows a plurality of isochrones **383** and an activation direction **384** of a mapped electrical signal. The plurality of isochrones **383** can be used to estimate conduction velocity magnitudes with various colors representing various different velocities. The EGM and position signals from the catheter's electrodes **385** were exported, along with a bipolar contact map of the LAT near the region of the catheter. The LAT map and its contours can be used to roughly predict an activation direction and velocity (a traditional approach). Because the procedure used during this activation was pacing from the CS, the expected activation direction **384** would be mostly anterior (-Y) and superior (+Z) with very little left/right (+/-X) component in the mapping system frame of reference. Conduction velocity, based on rough estimation using distances and color scales in the vicinity of the catheter, is expected to be around 1.0 mm/ms. As can be observed from comparing the left panel **381** and the right panel **382**, spline one **380** of the paddle catheter was off the surface of the atrium and hence the electrodes of spline one **380** were not considered for analysis. For the purpose of validation, cliques comprising four electrodes (two from each pair of adjacent splines as seen in FIG. **18**) were used.

[0145] FIG. **18** illustrates the paddle catheter **400** and the cliques used for the computation illustrated in FIG. **17**. The paddle catheter **400** can comprise a first spline **401**, a second spline **402**, a third spline **403**, and a fourth spline **404**. Each of the splines can comprise four electrodes. Rectangular cliques one **407**, two **408**, and three **409**, comprising electrodes (D,3,6,5), (2,3,7,6), and (3,4,8,7) respectively were not considered as spline one **401** (electrodes D,2,3,4) was deemed to be not in contact with the cardiac surface.

[0146] FIG. **19** shows the loop trajectory of vector E_t **420** in the tangent plane over 100 ms of the cardiac cycle when the catheter electrodes see atrial depolarization action. If the wavefront passes the clique electrodes progressing uniformly in a homogeneous medium (as seen in FIG. **4**), then vector E_t **420** should comprise voltage swings along a dominant axis aligned with the activation direction. The activation direction, calculated using the method described in the previous section is shown using the arrow. The plot shows the trajectory of vector E_t **420** over a single beat. The tail of the vector is at the isoelectric origin and the plurality of dots **421** indicate the head of the E field vector. The vector sweeps a loop around the origin with maximum and minimum excursions along the activation direction (indicated with the arrow).

[0147] FIG. **20A** shows the EGM's and the "equivalent bipole" E_a plotted as a function of time for two of the beats that were exported. Note that the morphology and amplitude of the signal is consistent from one beat to the other and that the far-field ventricular signal that we see in the unipolar EGM's is absent. The exemplary E_a has a sharp negative deflection followed by a sharp positive deflection. Also, its amplitude is expected to be solely a function of the substrate that is being investigated. FIG. **20B** shows the stylized shape of an exemplary E_a with a sharp negative deflection followed by a sharp positive deflection.

[0148] Due to various factors that contribute to non-ideal conditions, including finite spatial separation of electrodes, the morphologies of $\dot{\phi}$ and E_a do not match exactly but they

are very close to proportional. As a result the velocity magnitude is not uniform over the time interval of the beat. Also, when one or both of $\dot{\phi}$ and E_a of Equation 8 approaches zero, the algorithm fails to produce meaningful results. Under ideal conditions, $\dot{\phi}$ and E_a would tend to zero at the same instant in time and in the limit when they both tend to zero the ratio could be meaningfully evaluated to be the conduction velocity magnitude. In practice zero crossings of the denominator and numerator play havoc with this ratio.

[0149] The practical limitations can be overcome by realizing that classic unipolar signal recorded at an electrode includes contributions from depolarizing tissue upstream and downstream of the electrode location. The information about depolarizing tissue immediately under the electrode is contained within the region of maximal $-dv/dt$, peak negative deflection, and the immediate up stroke following the unipolar peak negative. This corresponds to the region contained within the peak negative and the subsequent positive peak in $\dot{\phi}$ and E_a . This region can be seen as time interval **501** in FIG. **21**. Conduction velocity is calculated using information from the signals within this region.

[0150] Listed below are some practical ways to calculate the velocity of activation or propagation. One way is to calculate the velocity as the ratio of the peak-to-peak values of $\dot{\phi}$ and E_a . The conduction velocity estimations shown in this section have been evaluated using this method. An equivalent mathematical way to represent a ratio of peak-to-peak values is shown with definite integrals below.

$$v = \frac{\int_{t_a}^{t_b} \frac{d\dot{\phi}}{dt} dt}{\int_{t_a}^{t_b} \frac{dE_a}{dt} dt} \quad (12)$$

[0151] In another embodiment the conduction velocity can be calculated by applying different weights to the information contained within the interval ($t_a < t' < t_b$) as follows

$$v = \frac{\int_{t_a}^{t_b} w \frac{d\dot{\phi}}{dt} dt}{\int_{t_a}^{t_b} w \frac{dE_a}{dt} dt} \quad (13)$$

where w is a weighting function. The weighting function can be used to ensure that more importance is given to certain regions within the time interval as shown in FIG. **22** and discussed below.

[0152] FIG. **21** illustrates a plot showing the time interval (from a to b) **501** that holds the most information about depolarizing tissue under a particular clique of electrodes. This generally corresponds to times around when the unipolar voltage is most negative which is when the inward current of depolarization is maximum under the electrodes of the clique. This introduces a practical and improved means to derive velocity from local $\dot{\phi}$ and E_a signals.

[0153] FIG. **22** depicts a weighting function w vs. time. W **505** is shown between time t_a **507** and time t_b **509**. In this illustration w is chosen to ensure more importance is given to the region corresponding to the zero-crossing of E_a following its pk-neg.

[0154] In some embodiments, determining the activation direction from the E field loop data can be overly sensitive to data taken when the loop is nearly isoelectric. OIS signals and derived quantities may reflect artifacts due to filtering, offsets, far field effects, or waveform complexity when good information also exists. The artifacts can be minimized by weighting the loop points in calculations, including activation direction cross correlation, not equally by time, but proportional to, or as a monotonic function of, $|d/dt(E(t))|$ as seen in FIG. 23. This can ensure that the E field data points that lie close to the origin or are changing slower than the depolarization, as seen in FIG. 23, are given less weight. Only the major deflections, which provide the necessary and key information about the underlying substrate, are then used for deriving OIS quantities, including the OIS coordinate frame ($\hat{n}, \hat{a}, \hat{w}$) and omnipole signals E_n and E_a . This can concentrate OIS results on the information containing part of the loop when the E field changes rapidly. This weighting can further be used in deriving OIS coordinate directions entirely from the E field loop, which could also lead to more accurate determination of E_n peak-to-peak, E_a peak-to-peak, and conduction velocity magnitude.

[0155] FIG. 23 illustrates an E-field loop showing regions of large and small $|d/dt(E(t))|$. The points 440 are EGM derived E-field points equally spaced in time. As discussed above, closely spaced points contain little information and contain artifacts that can affect OIS derived signals and EP characteristics. The area around the origin 441 has a small $|d/dt(E(t))|$, while the area with a large $|d/dt(E(t))|$ 443 corresponds to strong EGM signal amplitudes and deflections. The area with a large $|d/dt(E(t))|$ is of more interest. As a result, in one embodiment, those areas with a small $|d/dt(E(t))|$ can be removed or deemphasized.

[0156] In another embodiment, the loop points can also be weighted based on the magnitude of the E-field ($\text{norm}(E)$) which is the distance from the isoelectric origin. FIGS. 22A and 22B show the tangent E-field loop points before and after weighting based on the method described herein. FIG. 24A illustrates the tangent E-field loop 451 before weighting. FIG. 24B illustrates the tangent E-field loop 455 after weighting the loop points 457 based on the norm of the E-field. As can be seen in the comparison of FIGS. 22A and 22B, the part of the loop that contains the most useful EP information is accentuated and hence more meaningful OIS characteristics can be obtained from the weighted loop.

[0157] FIGS. 25A and 25B show the magnitude of conduction velocity estimated for each beat on the RA septal wall for two different cliques. FIG. 25A shows the magnitude of the conduction velocity for clique 6 and FIG. 25B shows the magnitude of the conduction velocity for clique 8. The velocity magnitude was estimated by taking the ratio of the peak-to-peak values of ϕ and E_a . The beat-to-beat variation in conduction velocity magnitude is minimal and the values of around 1.3 mm/ms are roughly what was expected. Conduction velocity magnitude and activation direction (unit vector) estimated for the two adjacent cliques were as follows.

[0158] Clique #6

[0159] Velocity magnitude= 1.35 ± 0.06 mm/ms

[0160] Activation direction= $(0.12, -0.91, 0.40)$

[0161] Clique #8

[0162] Velocity magnitude= 1.29 ± 0.05 mm/ms

[0163] Activation direction= $(0.10, -0.80, 0.58)$

[0164] The activation direction and velocity calculated were similar and consistent with expected results in atrial tissue.

[0165] FIG. 26 illustrates a saline tank test apparatus setup to simulate wavefront propagation with the horizontal source array 550. Wavefront propagation was setup in the test apparatus using a horizontal source array 550 by firing the electrodes on the array sequentially with a 3 ms delay to mimic wavefront propagation. Sets of 3 source electrodes (first set 553, second set 555, third set 557, and fourth set 559) separated by 10 mm were driven sequentially separated by 3 ms to summate in the neighboring saline and resemble propagation in vitro. The conduction velocity at the source array electrodes is thus $10 \text{ mm}/3 \text{ ms} = 3.33 \text{ mm/ms}$. Derived from physical measurements, this conduction velocity serves as a reference for subsequent determinations by traditional and orientation independent means. Each set of electrodes is driven by a single channel generator 560. A source array electrical diagram 561 is also illustrated showing a first set of electrodes 563, a second set of electrodes 565, a third set of electrodes 567, and a fourth set of electrodes 569.

[0166] When positioned at its standard location in the saline tank test apparatus, wavefront propagation in the apparatus should be about equal in the right (-X) and anterior direction (-Y) direction with virtually no component in the superior (+Z) direction. As a result the unit activation direction vector is predicted to be $(-0.71, -0.71, 0)$.

[0167] FIG. 27 shows a paddle catheter 580 in the saline tank test apparatus near the horizontal source array 581 simulating propagation. Wavefront propagation direction and velocity can be estimated from a gradient LAT map made from multiple precise contact map points on a spherical surface 583 near the source array electrodes. In one embodiment, the LAT map can comprise color gradients as known to those in the art. The earliest unipolar signals occur on the first set of waveforms 587 in the waveform window 589 on electrodes 13-16. The last unipolar signals occur on the second set of waveforms 585 on electrodes D-4. Using the precision contact map for activation times (± 0.5 ms due to sampling) and the measured interelectrode distances, a conduction velocity of 3.6 mm/ms ($\pm 10\%$ due to sampling) was determined at the center of the source array. This is close to the reference velocity of 3.33 mm/ms.

[0168] FIGS. 28 and 29, show plots of E_n , E_a , and conduction velocity derived from the paddle catheter in the same saline tank test apparatus propagation model discussed previously. Note that the E_a morphology is very similar to the exemplary signal discussed in the previous section. The conduction velocity and activation direction derived from OIS orientation independent fundamentals of wavefront propagation (and thus rely on the mapping system field scaling) was found to be in good agreement with the precision contact map and the reference values of 3.6 and 3.3 mm/ms respectively.

[0169] Clique #5

[0170] Velocity magnitude= 3.48 ± 0.02 mm/ms

[0171] Activation direction= $(-0.79, -0.61, -0.02)$

[0172] FIG. 28 illustrates a plot showing vector E_n 591 and the activation direction in the test apparatus over one beat. The action occurs in essentially a single direction, that of activation. FIG. 29 illustrates a plot showing omnipole E_a vs. time 593 in the test apparatus propagation model. Note that

the signal has the exemplary shape discussed in the previous section and shown from in vivo data in FIG. 20B.

[0173] The split tip catheter discussed previously is also suitable for bipolar pacing in a manner that is much more tip localized than the conventional D-2 bipolar pacing and free of the concern over variable locational of capture (and variable thresholds) that can occur when the ring (and not the tip) captures myocardium. This is a great advantage when, for example, pacing is being done to establish lesion efficacy. The alternative, unipolar pacing, involves a distant electrode and thus is responsible for a large pacing artifact that complicates use of pacing for assessing blocks. The basic idea is that pacing is accomplished by assigning alternating polarities to the four tip electrodes. This too may be accomplished by circuit elements such that the four electrograms and mapping system positions remain distinct and yet the tip appears as a “crossed bipole” from the standpoint of pacing. Alternatively this may be done by employing the stimulator, devoting two simultaneous channels to the four electrodes.

[0174] With each local depolarization, a new conduction velocity vector may be generated. The system can be configured to display various information including oriented arrow icons, Matlab quiver-like plots, and ripple maps. The system can further have the option to control the persistence of these direction and/or magnitude renderings. In one embodiment, the default process is to update immediately with each new local depolarization (that meets criteria for a depolarization).

[0175] Updates that visually replace prior visual assessments are sometimes preferred over cumulative multi-beat maps because if there is only modest movement of the catheter between repeated similar beats, the map will become cluttered with such representations. As a result, it can be beneficial to include a spatial density criterion (like that currently available with traditional mapping systems). New representation points would be added if none are within say 2 mm of previous points (and from same mapped rhythm if that is distinguished). If old points lie within 2 mm of a new point, the new points can delete or hide old points. Particularly when playing back recorded segments and focus is on a region of interest where a multi-electrode mapping catheter is, the system can hide/delete prior representation points in favor of the most recent cardiac cycle since play back began.

[0176] In another embodiment, a variable persistence can be given to the point representations based on, a given number of milliseconds duration and observed during slow playback. The points can come into existence and disappear in a manner that (similar to a propagation map available on the EnSite Velocity mapping system) suggests the wavefront itself (a region of typically 1 cm or so wide that encompasses the 10 ms or so of primary depolarization current and EGM generation). This can benefit the system by removing clutter and focusing attention on immediate events.

[0177] Transmural RF ablation possesses certain EGM characteristics which are exploitable by an orientation independent, OIS catheter electrode design and software. In particular, the unipolar signal (which to a first approximation is just a polarity inverted E_n signal) may change from an rS pattern preablation to a r' pattern afterward. As a result, E_n can change from a nice dominant upward deflection to a smaller downward deflection, perhaps a downward deflec-

tion that was present previously, but now appears minor in comparison with the upward deflection.

[0178] In one embodiment, using a paddle catheter like that illustrated in FIG. 2A and FIG. 18, the regular rectangular arrangement of cliques can be used. Each clique under consideration can receive a score determined for how the pattern in the cliques adjacent to it matches templates for uniform, focal source, and rotational conduction. The templates can be made with unit vectors in a uniform direction, radially inward or outward from clique under consideration, and in a clockwise or counterclockwise orientation perpendicular to the radial directions. Scores can be calculated by taking dot products of the OIS derived CV vectors (preferably unit vectors) computed at the cliques with the corresponding unit vectors on the template.

[0179] FIGS. 30A and 30B illustrate one embodiment of a scoring system and results for cases when the rectangular clique under consideration is either a center clique 611 or an edge clique 621. The scoring system can be used to determine and display the degree to which the catheter's cliques match uniform propagation, focal source/sink activation, or rotary motion. FIG. 30A shows a nine clique FIG. 601 with a scoring diagram 612 for a center clique 611. The scores from a uniform test pattern 613, a source test pattern 614, and a rotor test pattern 615 are shown when each pattern is compared to a template uniform conduction 616, a template source 617, and a template rotor 618. The maximum score for a center clique 611 in this embodiment is 8, as that is the number of cliques that surround the center clique 611. The scoring diagram 612 illustrates that when comparing the uniform test pattern 613 with template uniform conduction 616, a score of 8 results. When comparing the uniform test pattern 613 with the template source 617, a score of 0 results. When comparing the uniform test pattern 613 with the template rotor 618, a score of 0 results. So if the true or observed pattern was uniform conduction, this would lead to a score of (8,0,0) as described in relation to FIG. 33. When comparing the source test pattern 614 with the template uniform conduction 616, a score of 0 results. When comparing the source test pattern 614 with the template source 617, a score of 8 results. When comparing the source test pattern 614 with the template rotor 618, a score of 0 results. This leads to a score of (0,8,0) for a true source located at 611. When comparing the rotor test pattern 615 with the template uniform conduction 616, a score of 0 results. When comparing the rotor test pattern 615 with the template source 617, a score of 0 results. When comparing the rotor test pattern 615 with the template rotor 618, a score of 8 results. This leads to a score of (0,0,8) for rotation about 611.

[0180] FIG. 30B shows a nine clique FIG. 603 with a scoring diagram 622 for an edge clique 621. The scores from a uniform test pattern 623, a source test pattern 624, and a rotor test pattern 625 are shown when each pattern is compared to a template uniform conduction 626, a template source 627, and a template rotor 628. The maximum score for an edge clique 621 in this embodiment is 5, as that is the number of cliques that surround the edge clique 621. The scoring diagram 622 illustrates that when comparing the uniform test pattern 623 with template uniform conduction 626, a score of 5 results. When comparing the uniform test pattern 623 with the template source 627, a score of 2 results. When comparing the uniform test pattern 623 with the template rotor 628, a score of 0 results. This leads to a score of (5,2,0) at 621 as described in relation to FIG. 33.

When comparing the source test pattern **624** with the template uniform conduction **626**, a score of 2 results. When comparing the source test pattern **624** with the template source **627**, a score of 5 results. When comparing the source test pattern **624** with the template rotor **628**, a score of 0 results. This leads to a score of (2,5,0) at **621**. When comparing the rotor test pattern **625** with the template uniform conduction **626**, a score of 0 results. When comparing the rotor test pattern **625** with the template source **627**, a score of 0 results. When comparing the rotor test pattern **625** with the template rotor **628**, a score of 5 results. This leads to a score of (0,0,5) at **621**.

[0181] When testing against an observed pattern against a template for uniform conduction, it must be tested multiple times with vectors of the uniform conduction templates facing different directions. In one embodiment, the vectors making up each template are rotated 2 degrees and tested again. This process is repeated with the vectors being rotated through a full 360 degrees each time to ensure that the scoring system can be aligned with actual conduction. In this embodiment, the highest overall score for uniform conduction is then used by the system.

[0182] This approach can be further generalized to 2D triangular or quadrilateral cliques such as those that can occur with a helical basket catheter design or more common basket catheter designs. FIG. **30** shows a list of scoring for two of the three types of cliques in the rectangular grid of electrodes seen in FIG. **18**. The scoring can involve a variable number of adjacent cliques. The more cliques the higher the possible score for each of the 3 types. Higher scores are associated with greater certainty.

[0183] FIG. **31** illustrates an more in-depth scoring diagram **651** for a nine clique figure with a corner clique **652**. As before, when the observed pattern being tested matches the true template, the scores are highest. In the illustrated embodiment a maximum of 3.0 is shown reflecting the three adjacent rectangular cliques. The lowest scores result from testing a focal source/sink against a rotor or vice versa. The scores from a uniform test pattern **661**, a source test pattern **662**, and a rotor test pattern **663** are shown when each pattern is compared to a template uniform conduction **655**, a template source **656**, and a template rotor **657**. The scoring diagram **651** illustrates that when comparing the uniform test pattern **661** with template uniform conduction **655**, a score of 3 results. When comparing the uniform test pattern **661** with the template source **656**, a score of 1.5 results. When comparing the uniform test pattern **661** with the template rotor **657**, a score of 1.5 results. This leads to a score of (3,1.5,1.5) at **652** as described in relation to FIG. **33**. When comparing the source test pattern **662** with the template uniform conduction **655**, a score of 1.5 results. When comparing the source test pattern **662** with the template source **656**, a score of 3 results. When comparing the source test pattern **662** with the template rotor **657**, a score of 0 results. This leads to a score of (1.5,3,0) at **652**. When comparing the rotor test pattern **663** with the template uniform conduction **655**, a score of 1.5 results. When comparing the rotor test pattern **663** with the template source **656**, a score of 0 results. When comparing the rotor test pattern **663** with the template rotor **657**, a score of 3 results. This leads to a score of (1.5,0,3) at **652**.

[0184] In one embodiment, a conventional 1-D color scale or gray scale coloring scheme can be used for any one of the major patterns (e.g. rotors, uniform conduction or focal source).

[0185] However in another embodiment, as illustrated in FIG. **32**, a color can be assigned from a color triangle **701** according to each score type. For example, if red **703** is used to represent rotors and green **705** for uniform conduction, then yellow **709** can be used to represent a pattern that resembles a rotor and uniform propagation equally. Similarly, blue **707** can be used to represent a focal source. This would result in a cyan or blue-green **713** being displayed to represent a pattern that resembles a focal source and a uniform conduction equally. Further, purple **711** would be displayed to represent a patter that resembles a focal source and a rotor equally. White or the absence of color **715** can be used to represent a score that equally shows a rotor, a focal source, and a uniform conduction. By using an absence of color, a user would be able to more easily determine that a score is inconclusive. The color triangle **701** can be used to associate a specific color to the set of scores for all of the cliques. The absolute value of scores can be used so that both rotor directions (clockwise and counterclockwise) need not be represented differently. This can similarly apply for focal sources and sinks. Distinguishing these visually is a simple matter of superimposing velocity vector arrows. As the type of clique (center, side, or corner) determines the maximum score and certainty, this can also be represented. The highest scores can be visually represented as fully opaque (or near so) and the lowest scores most translucent. Alternatively, stippling to various levels could be used. The colors of the color triangle **701** can fade from one color to the other colors as the color triangle is moved along from one corner to another. As an example, when moving along an outer axis of the triangle from red **703** to green **705**, the color triangle **701** can show a brief amount of orange before turning to yellow **709**. The color triangle can further turn from yellow **709** to a yellow-green, before moving to green **705** as the green corner of the color triangle **701** is reached.

[0186] In some embodiments a module to translate from the 3 scores for each template type to a location on the 2D triangle above can still be needed. FIG. **33** illustrates one embodiment of a way of doing this. Barycentric coordinates from normalized scores govern the choice of displayed color. As illustrated, (1,0,0) is at the top **751**, (0,0,1) is at the bottom right **755** of the triangle, and (0,1,0) is at the bottom left **753** of the triangle. An example of the color triangle in use can include a center clique evaluated to the following set of scores (recall the maximum is 8): (5,5,0) representing the degree of match to rotor, uniform, or focal conduction in that order. The scores are normalized by dividing this triple by the L1 norm (sum of absolute values) to obtain (0.5,0.5,0) **761**. This is recognized as specifying yellow on the color triangle above. The level of translucency of yellow is determined by ratio of the L ∞ norm (the maximum absolute value) here 5, to its maximum possible value 8. As a result, a translucency/opacity score of 5/8 denotes moderate certainty. If the scores had been (8,0,0) the perfect match to a rotor would result in a color triangle value of (1,0,0) and a translucency (or better said opacity) score of 1.0 for complete certainty. Further combinations of the triangle include (0.5,0.25,0.25) **765**, (0.5,0,0.5) **759**, (0.33,0.33,0.33) **763**, (0.25,0.5,0.25) **767**, (0.25,0.25,0.5) **769**, and (0,0.5,0.5) **761**.

[0187] Searching for a rotor center or focal source is facilitated by the beat-by-beat colored display. If for example, a rotor is sought, one moves the paddle catheter about until a corner or edge obtains a reddish hue. The whole paddle is then moved in that direction until the center clique is as red as possible and the surrounding clique colors are red-tinged.

[0188] FIG. 34 illustrates an embodiment of a system 860 comprising a scoring module 895 as described above that can compute and output a scoring system for collected data. The system 860 comprises, among other components, a medical device 862 and a model construction system 864. In one embodiment, the medical device 862 comprises a catheter, and the model construction system 864 comprises, in part, a processing apparatus 866. The processing apparatus 866 may take the form of an electronic control unit, for example, that is configured to obtain a geometry surface model of the cardiac structure, and to construct an EP map corresponding to the cardiac structure using data collected by, for example, the catheter 862. The model construction system 864 can further be coupled to a scoring module 895 that can process the score of any clique as described above and output that information to a display device 894. In one embodiment, the scoring module 895 can be a software program loaded on to the model construction system 864. In other embodiments, the scoring module 895 can be a separate piece of hardware communicatively coupled to the model construction system 864. The catheter 862 is configured to be inserted into a patient's body 868, and more particularly, into the patient's heart 870. The catheter 862 may include a cable connector or interface 872, a handle 874, a shaft 876 having a proximal end 878 and a distal end 880 and one or more sensors 882 mounted in or on the shaft 876 of the catheter 862. In one embodiment, the sensors 882 are disposed at or near the distal end 880 of the shaft 876. The connector 872 provides mechanical, fluid, and electrical connection(s) for cables, such as, for example, cables 884, 886 extending to the model construction system 864 and/or other components of the system 860 (e.g., a visualization, navigation, and/or mapping system (if separate and distinct from the model construction system 864), an ablation generator, irrigation source, etc.).

[0189] The sensors 882 mounted in or on the shaft 876 of the catheter 862 are electrically connected to the model construction system 864, and the processing apparatus 866 thereof, in particular. The sensors 882 may be provided for a variety of diagnostic and therapeutic purposes including, for example and without limitation, EP studies, pacing, cardiac mapping, and ablation. In an one embodiment, one or more of the sensors 882 are provided to perform a location or position sensing function. Accordingly, in such an embodiment, as the catheter 862 is moved along a surface of the cardiac structure and/or about the interior thereof, the sensor(s) 882 can be used to collect location data points that correspond to the surface of, or locations within, the cardiac structure. These location data points can then be used by, for example, the model construction system 864 in the construction of a geometry surface model of the cardiac structure.

[0190] Various embodiments are described herein to various apparatuses, systems, and/or methods. Numerous specific details are set forth to provide a thorough understanding of the overall structure, function, manufacture, and use of the embodiments as described in the specification and illustrated in the accompanying drawings. It will be understood

by those skilled in the art, however, that the embodiments may be practiced without such specific details. In other instances, well-known operations, components, and elements have not been described in detail so as not to obscure the embodiments described in the specification. Those of ordinary skill in the art will understand that the embodiments described and illustrated herein are non-limiting examples, and thus it can be appreciated that the specific structural and functional details disclosed herein may be representative and do not necessarily limit the scope of the embodiments, the scope of which is defined solely by the appended claims.

[0191] Reference throughout the specification to “various embodiments,” “some embodiments,” “one embodiment,” or “an embodiment”, or the like, means that a particular feature, structure, or characteristic described in connection with the embodiment is included in at least one embodiment. Thus, appearances of the phrases “in various embodiments,” “in some embodiments,” “in one embodiment,” or “in an embodiment”, or the like, in places throughout the specification are not necessarily all referring to the same embodiment. Furthermore, the particular features, structures, or characteristics may be combined in any suitable manner in one or more embodiments. Thus, the particular features, structures, or characteristics illustrated or described in connection with one embodiment may be combined, in whole or in part, with the features structures, or characteristics of one or more other embodiments without limitation given that such combination is not illogical or non-functional.

[0192] It will be appreciated that the terms “proximal” and “distal” may be used throughout the specification with reference to a clinician manipulating one end of an instrument used to treat a patient. The term “proximal” refers to the portion of the instrument closest to the clinician and the term “distal” refers to the portion located furthest from the clinician. It will be further appreciated that for conciseness and clarity, spatial terms such as “vertical,” “horizontal,” “up,” and “down” may be used herein with respect to the illustrated embodiments. However, surgical instruments may be used in many orientations and positions, and these terms are not intended to be limiting and absolute.

What is claimed is:

1. A system for determining electrophysiological data comprising:

an electronic control unit configured to:

acquire electrophysiology signals from a plurality of electrodes of one or more catheters;

select at least one clique of electrodes from the plurality of electrodes to determine a plurality of local E field data points;

determine the location and orientation of the plurality of electrodes;

process the electrophysiology signals from the at least one clique from a full set of bipole subcliques to derive the local E field data points associated with the at least one clique of electrodes;

derive at least one orientation independent signal from the at least one clique of electrodes from the information content corresponding to weighted parts of electrogram signals; and

display or output catheter orientation independent electrophysiologic information to a user or process.

2. The system of claim 1, wherein the at least one orientation independent signal comprises at least one of En,

Ea, Ew, E, and Et and wherein the at least one orientation independent signal comprises an omnipole.

3. The system of claim 2, wherein the electronic control unit is further configured to use the at least one orientation independent signal to derive at least one of an electrogram amplitude, an activation timing, and a conduction velocity vector.

4. The system of claim 3, wherein the electronic control unit is further configured to derive the conduction velocity from an activation direction and an equivalent bipole.

5. The system of claim 1, wherein the electronic control unit is configured to derive the local E field by choosing one of the electrodes within the at least one clique of electrodes as a reference electrode and to determine n-1 bipolar potentials and displacements of the remaining electrodes of the at least one clique with respect to the reference electrode.

6. The system of claim 2, wherein the electronic control unit is further configured to weight the E field data points to derive other orientation independent indices of electrophysiologic function such as substrate voltage amplitude, local activation timing, or conduction velocity.

7. The system of claim 6, wherein the plurality of E field data points form an E field loop, and wherein the electronic control unit is further configured to weight each of the E field data points based on the distance of a point in the E field from an isoelectric origin.

8. The system of claim 7, wherein the electronic control unit is further configured to determine the conduction velocity after the E field loop components have been weighted.

9. The system of claim 6, wherein the plurality of E field data points form an E field loop, and wherein the electronic control unit is further configured to weight the data points in the E-field loop based on $|d/dt(E(t))|$.

10. The system of claim 1, wherein the at least one clique of electrodes is an overdetermined clique and the at least one clique can comprise a plurality of subcliques.

11. The system of claim 1 wherein the electronic control unit is further configured to use at least one criteria to determine whether each at least one clique is in contact with a target surface.

12. The system of claim 11, wherein the at least one criteria comprises at least one of an angular deviation, a distance between the at least one clique and a target surface, an amplitude of a unipolar signal obtained from each of the electrodes in a clique, the morphology of unipolar signals obtained from the electrodes in a clique, and the characteristics of E_t and E_a from a clique.

13. The system of claim 12, wherein a user or process selects one or more of the criteria used to determine whether each at least one clique is in contact with a target surface.

14. A method for determining electrophysiological data comprising:

acquiring electrophysiology signals from a plurality of electrodes of one or more catheters;

selecting at least one clique of electrodes from the plurality of electrodes to determine a plurality of local E field data points;

determining the location and orientation of the plurality of electrodes;

processing the electrophysiology signals from the at least one clique from a full set of bipole subcliques to derive the local E field data points associated with the at least one clique of electrodes;

deriving at least one orientation independent signal from the at least one clique of electrodes from the information content corresponding to weighted parts of electrogram signals; and

displaying or output catheter orientation independent electrophysiologic information to a user or process.

15. The method of claim 14, wherein the at least one orientation independent signal comprises at least one of En, Ea, and Et.

16. The method of claim 14, further comprising using the at least one orientation independent signal to derive at least one of an electrogram amplitude, an activation timing, and a conduction velocity.

17. The method of claim 14, further comprising weighting the E field data points to derive other orientation independent indices of electrophysiologic function such as substrate voltage amplitude, local activation timing, or conduction velocity.

18. A circuit box adapter comprising:

circuitry to interface an electrode ablation catheter to both an RF generator and EP mapping system; the circuitry operable between a first state to allow a plurality of catheter electrodes to separately sense electrical signals in a first mode and a second state to emit energy from a single output from an ablation generator in a second mode,

wherein, in the first state, the circuitry is configured to allow passive isolation of the plurality of segmented catheter electrodes for operation in the first mode.

19. The circuit box adapter of claim 18, wherein the circuitry further comprises a plurality of capacitors.

20. The circuit box adapter of claim 18, wherein the plurality of electrodes comprises between three and six tip electrodes.

* * * * *

专利名称(译)	使用多电极导管对心脏基质进行局部电生理学表征的系统和方法		
公开(公告)号	US20170042449A1	公开(公告)日	2017-02-16
申请号	US15/118522	申请日	2015-02-25
[标]申请(专利权)人(译)	圣犹达医疗用品心脏病学部门有限公司		
申请(专利权)人(译)	ST.犹达医疗用品, 心脏病DIVISION, INC.		
当前申请(专利权)人(译)	ST.犹达医疗用品, 心脏病DIVISION, INC.		
[标]发明人	DENO D CURTIS BALACHANDRAN RAM K		
发明人	DENO, D. CURTIS BALACHANDRAN, RAM K.		
IPC分类号	A61B5/06 A61B5/044 A61B18/14 A61B5/04 A61M25/01 A61B5/042 A61B5/00		
CPC分类号	A61B5/068 A61B5/0422 A61B5/044 A61B5/062 A61B5/6858 A61M2025/0166 A61M25/0127 A61B18/1492 A61B2018/00577 A61B2018/00839 A61B2562/0214 A61B5/04012 A61B5/0044 A61B5/04011 A61B5/0402 A61B5/0452 A61B5/6852 A61B5/6869 A61B5/72 A61B5/7239 A61B5/7264 A61B2560/066 A61B2562/0209 A61B2562/04 A61B2562/046		
优先权	61/944426 2014-02-25 US		
其他公开文献	US10470682		
外部链接	Espacenet USPTO		

摘要(译)

一种用于确定电生理数据的系统，包括：电子控制单元，被配置为从一个或多个导管的多个电极（130）获取电生理信号，从所述多个电极中选择至少一个电极组（136）确定多个局部E场数据点，确定多个电极的位置和方向，处理来自全套双极子子集的至少一个团的电生理信号以导出与至少一个电极组相关联的局部E场数据点从与所述加权部分对应的信息内容导出来自所述至少一个电极团（138）的至少一个取向独立信号。电描记图信号，并向用户或过程显示或输出导管取向独立的电生理信息。

