



US 20190231241A1

(19) **United States**

(12) **Patent Application Publication**
Al-Ali et al.

(10) **Pub. No.: US 2019/0231241 A1**

(43) **Pub. Date: Aug. 1, 2019**

(54) **WIRELESS PATIENT MONITORING DEVICE**

Publication Classification

(71) Applicant: **Masimo Corporation**, Irvine, CA (US)

(51) **Int. Cl.**

A61B 5/1455 (2006.01)

A61B 5/0295 (2006.01)

A61B 5/00 (2006.01)

A61B 5/026 (2006.01)

(72) Inventors: **Ammar Al-Ali**, San Juan Capistrano, CA (US); **Eric Karl Kinast**, Santa Ana, CA (US); **Bilal Muhsin**, San Clemente, CA (US); **Chad A. DeJong**, Los Angeles, CA (US)

(52) **U.S. Cl.**

CPC *A61B 5/14552* (2013.01); *A61B 5/0295* (2013.01); *A61B 5/002* (2013.01); *A61B 5/7405* (2013.01); *A61B 5/6826* (2013.01); *A61B 2560/0214* (2013.01); *A61B 5/6831* (2013.01); *A61B 5/7425* (2013.01); *A61B 5/725* (2013.01); *A61B 5/0261* (2013.01); *A61B 5/746* (2013.01); *A61B 5/6833* (2013.01)

(21) Appl. No.: **16/182,427**

(22) Filed: **Nov. 6, 2018**

Related U.S. Application Data

(63) Continuation of application No. 13/762,270, filed on Feb. 7, 2013, now Pat. No. 10,149,616.

(60) Provisional application No. 61/597,126, filed on Feb. 9, 2012, provisional application No. 61/625,584, filed on Apr. 17, 2012, provisional application No. 61/703,713, filed on Sep. 20, 2012.

(57)

ABSTRACT

A device for obtaining physiological information of a medical patient and wirelessly transmitting the obtained physiological information to a wireless receiver.

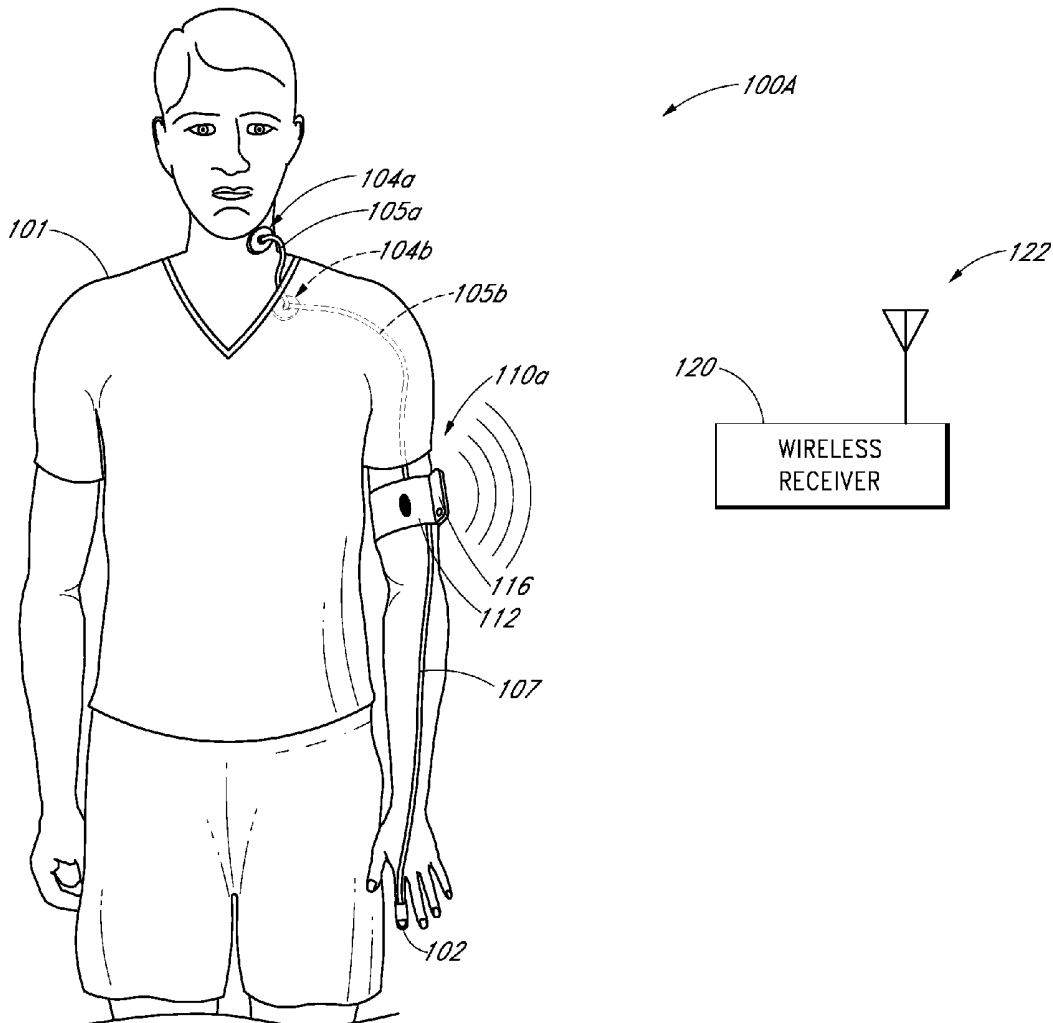

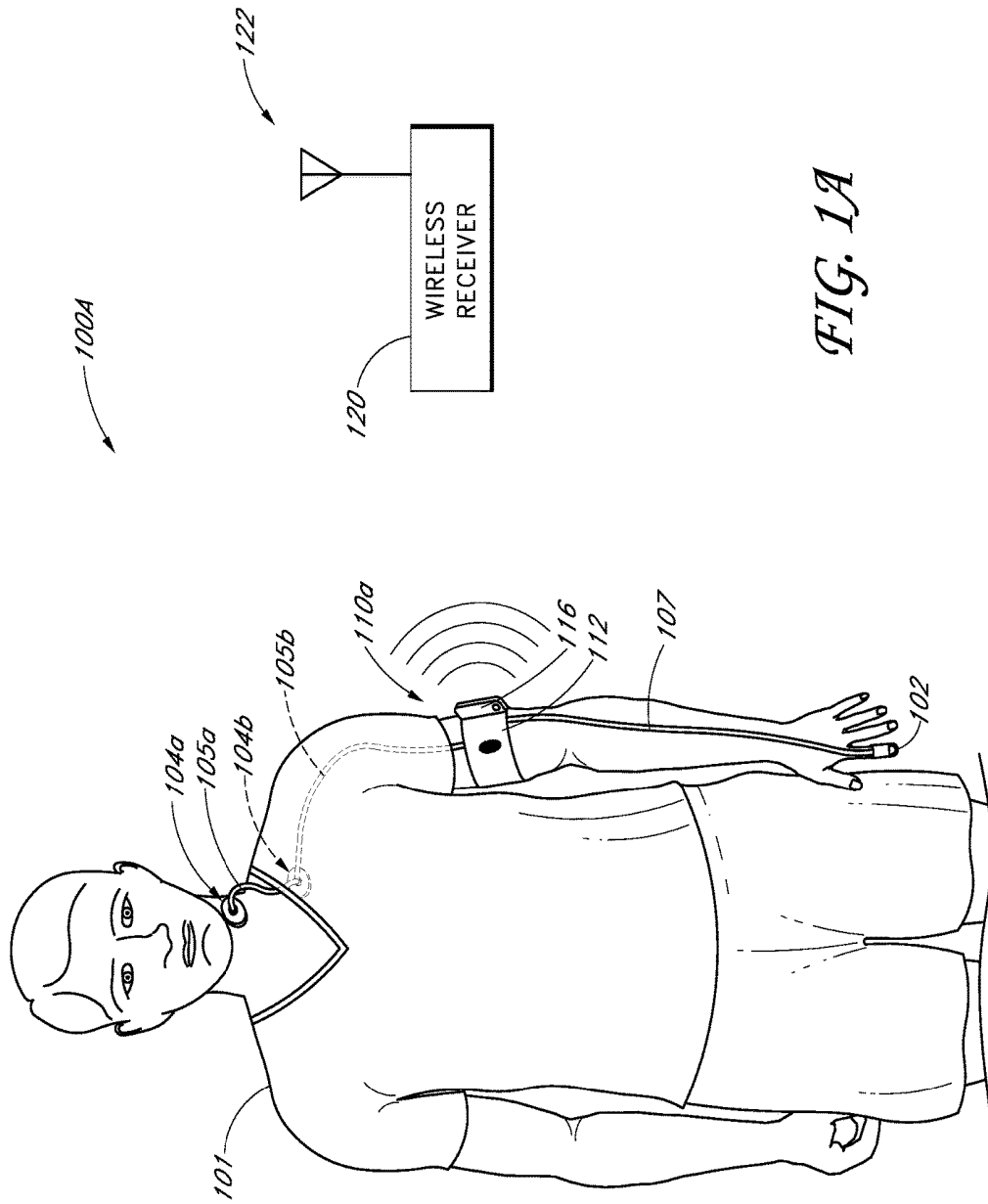

FIG. 1A

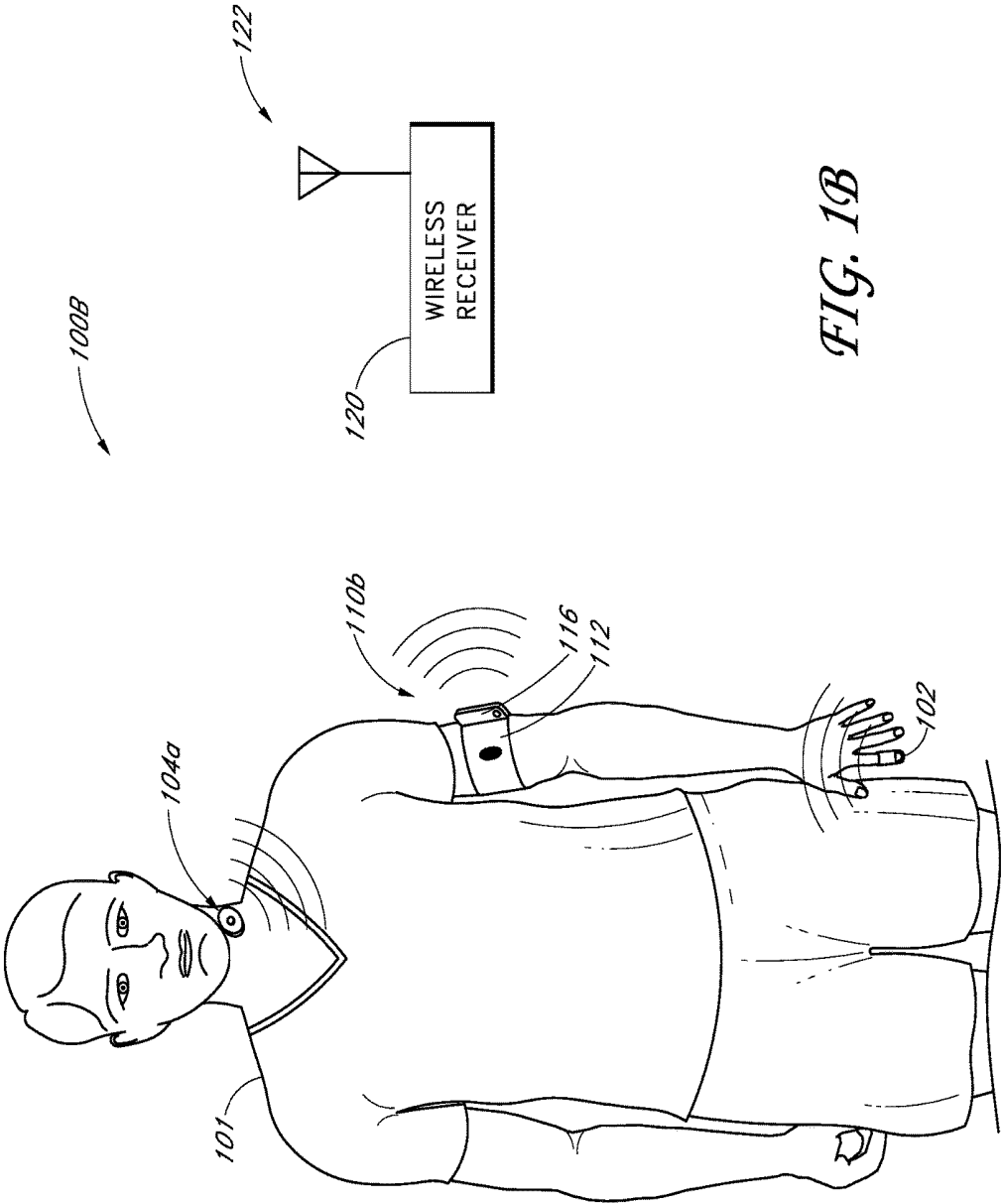

FIG. 1B

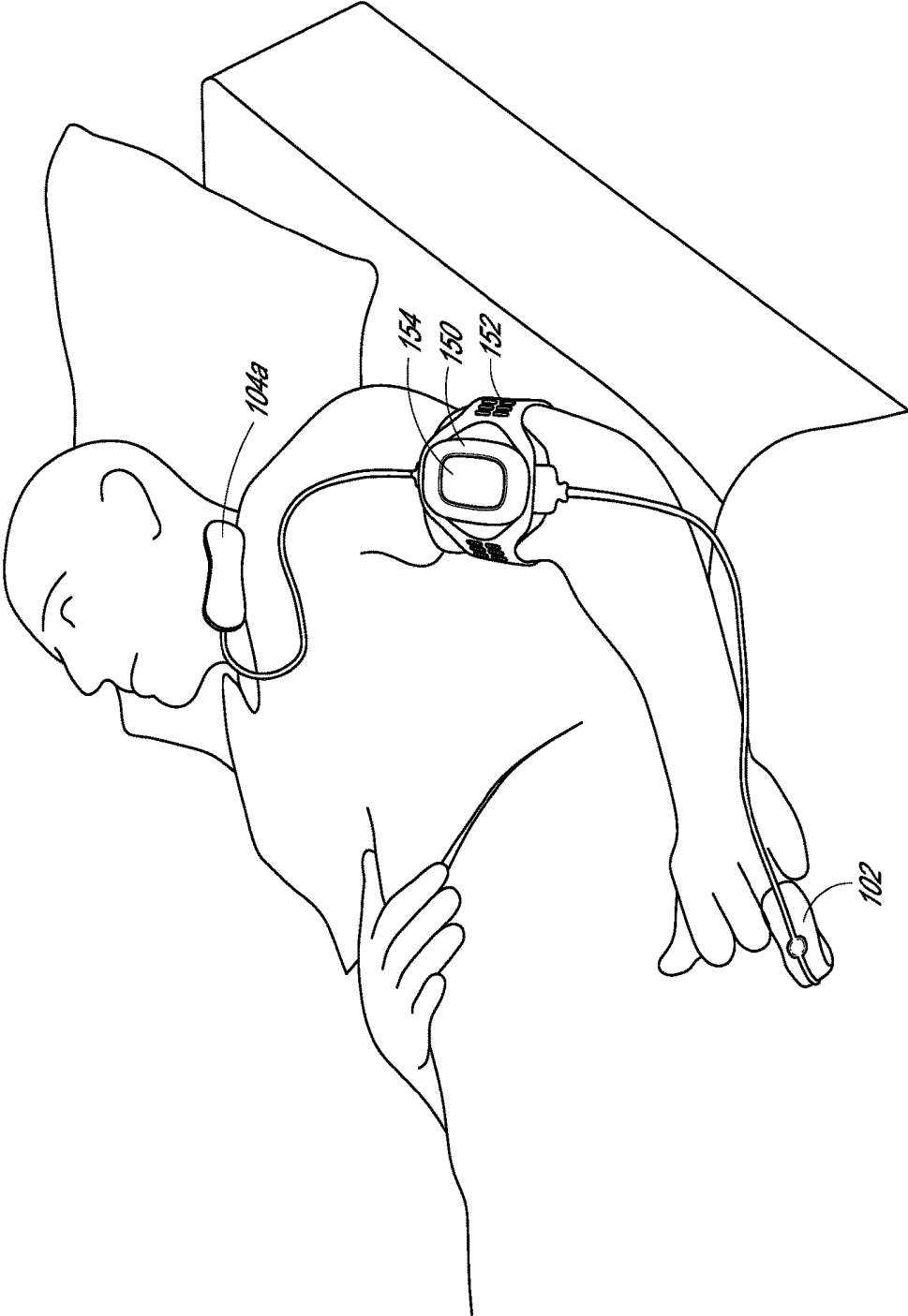

FIG. 1C

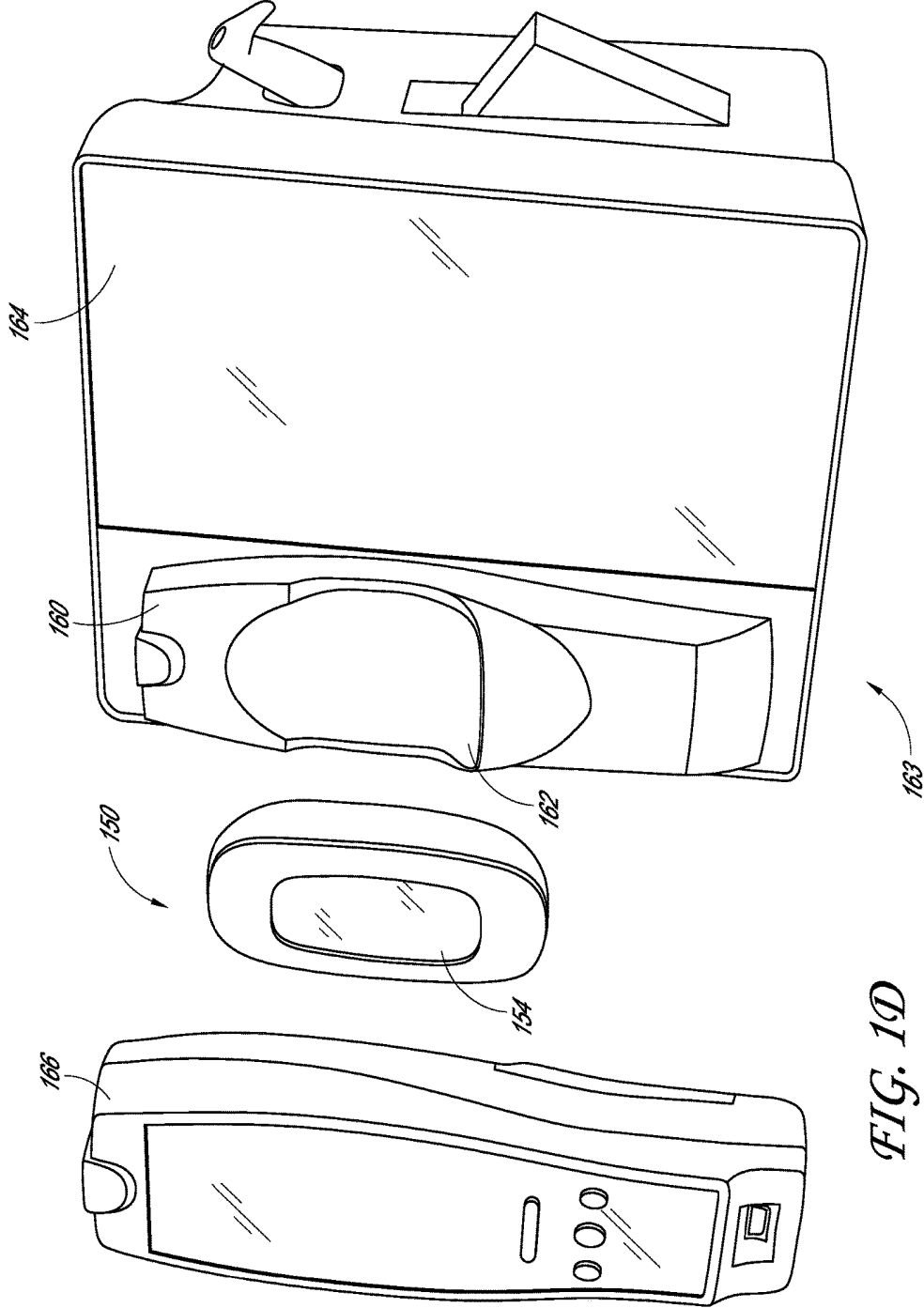

FIG. 1D

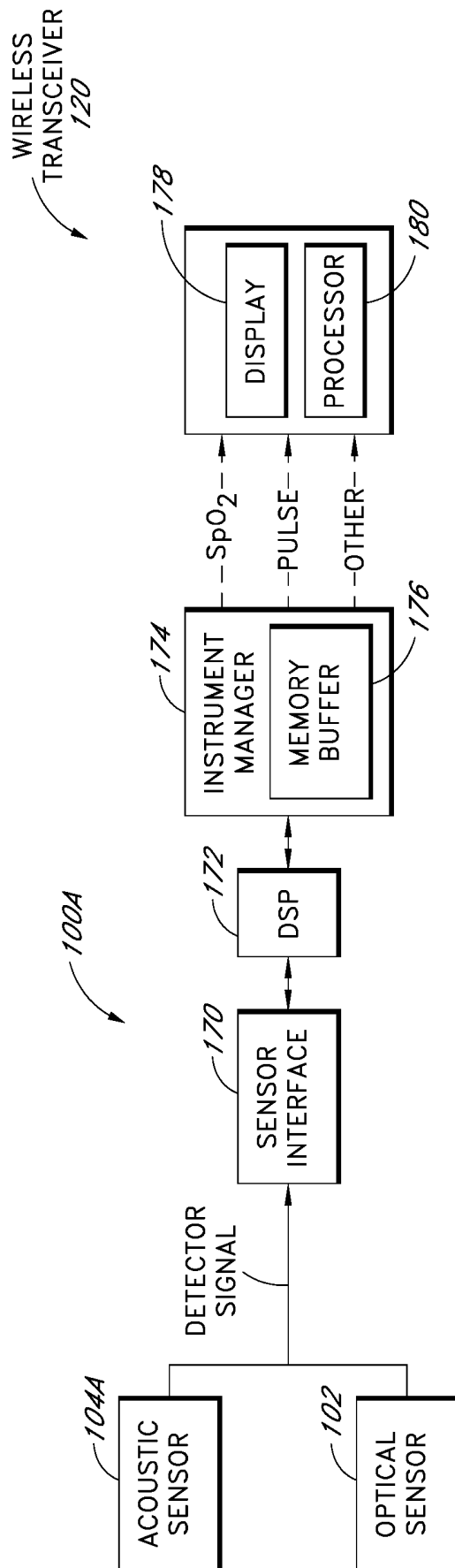

FIG. 1E

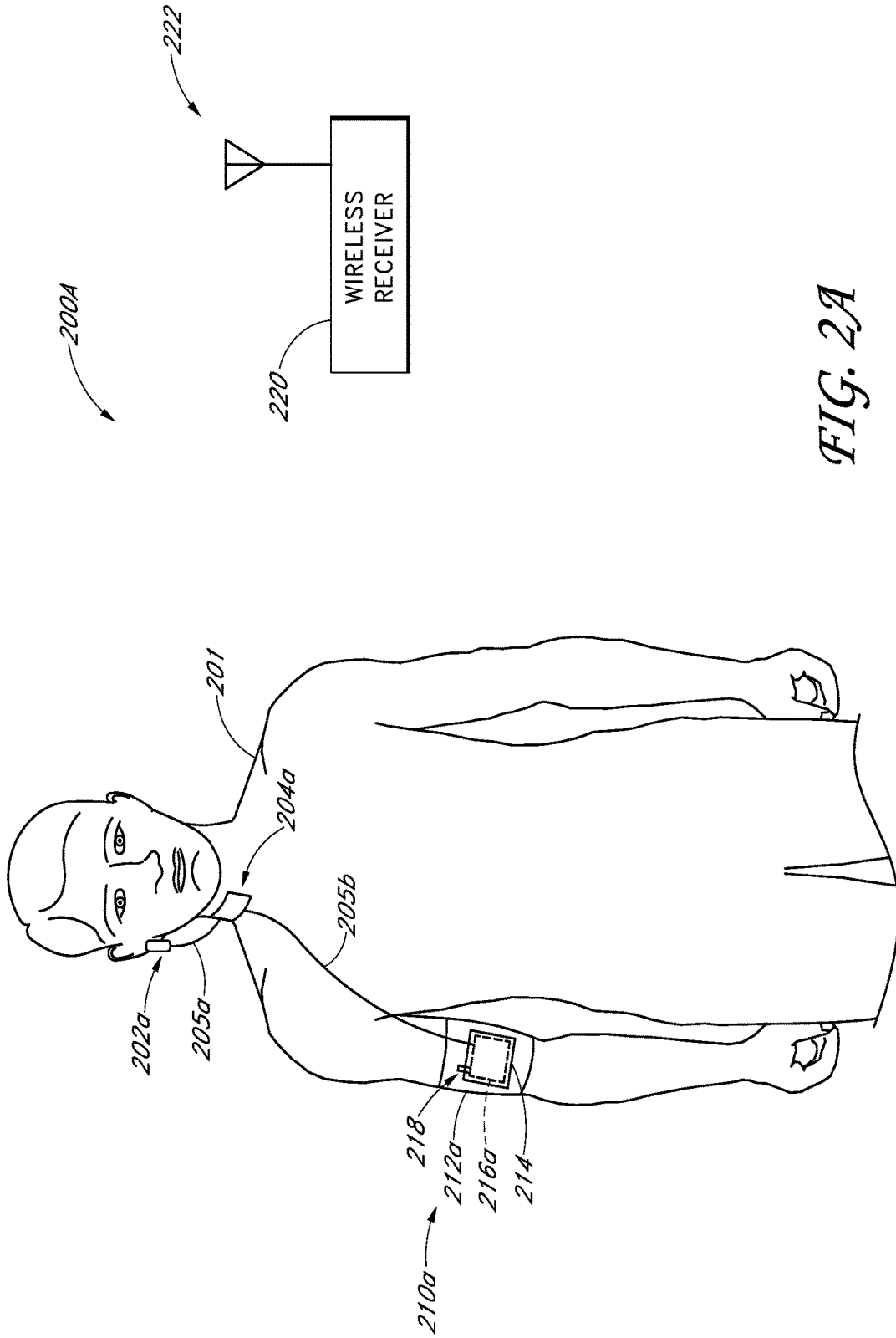

FIG. 2A

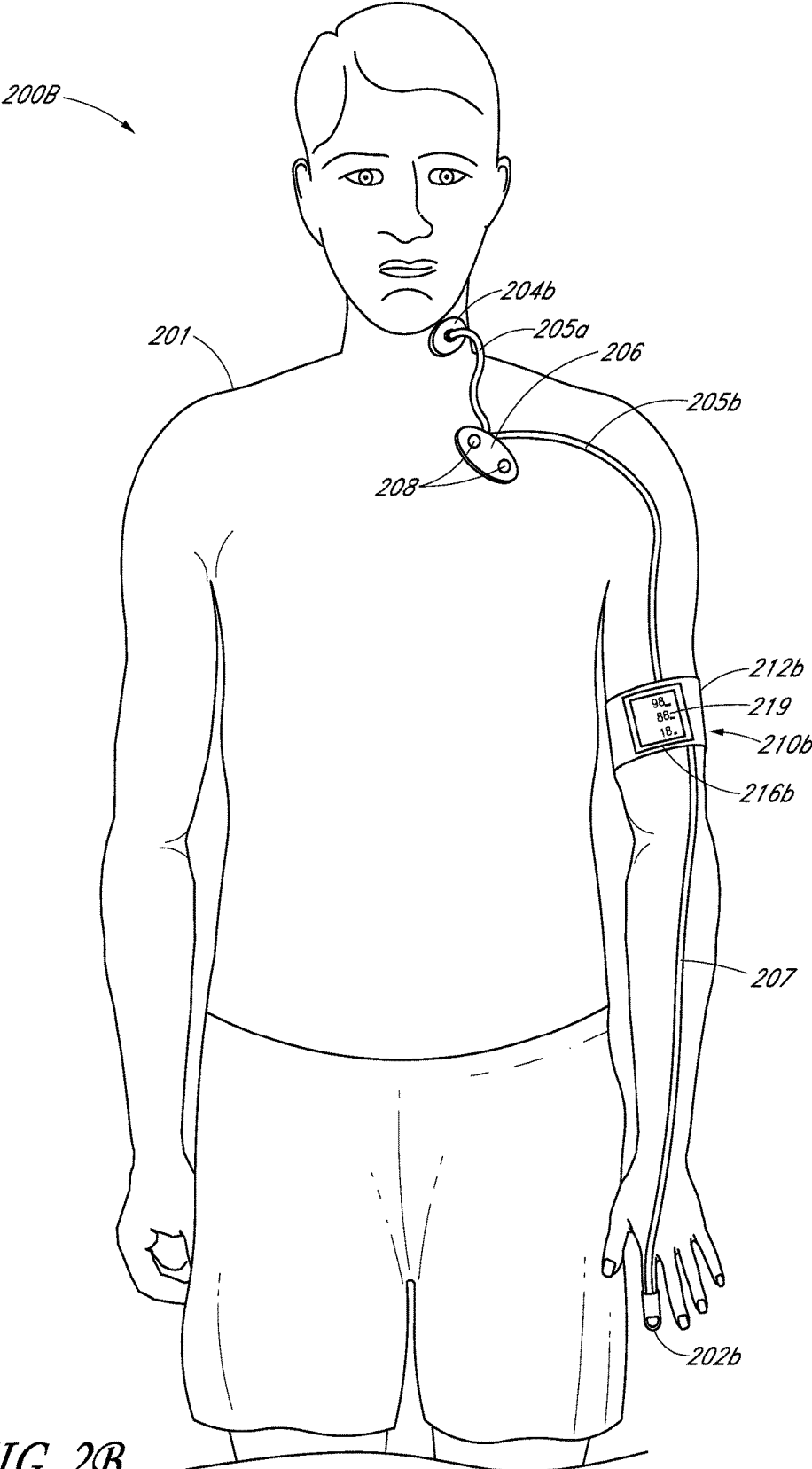

FIG. 2B

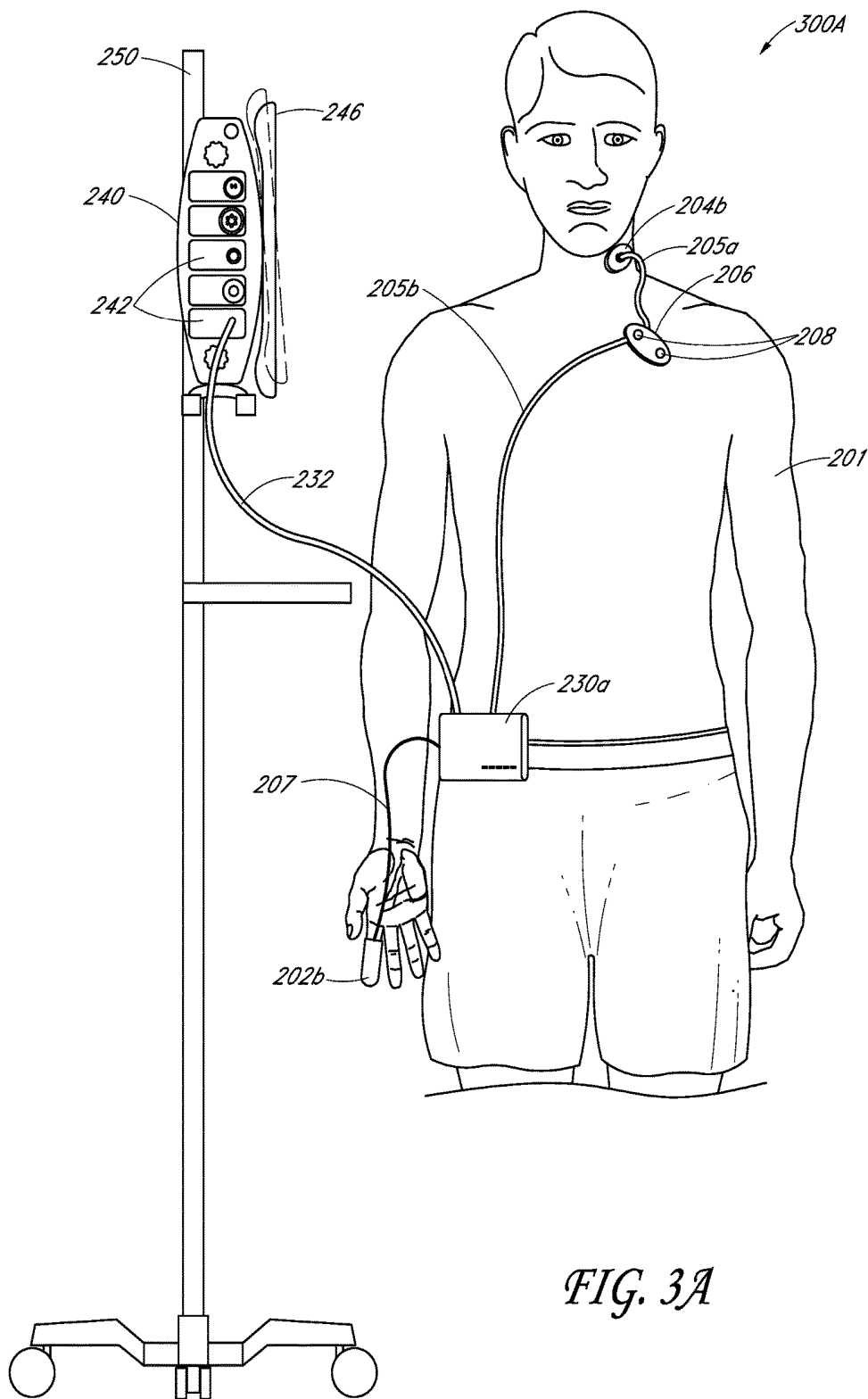

FIG. 3A

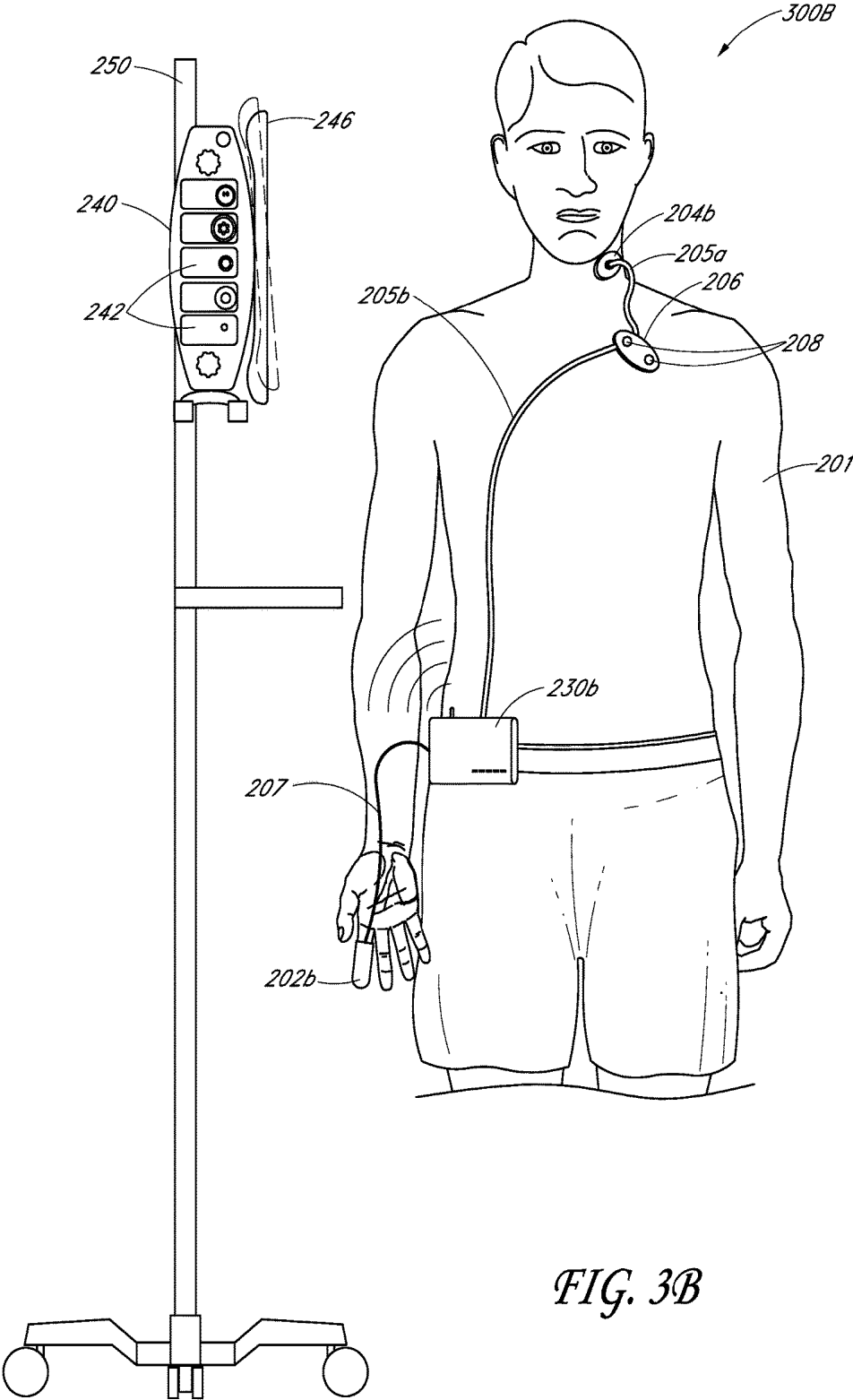

FIG. 3B

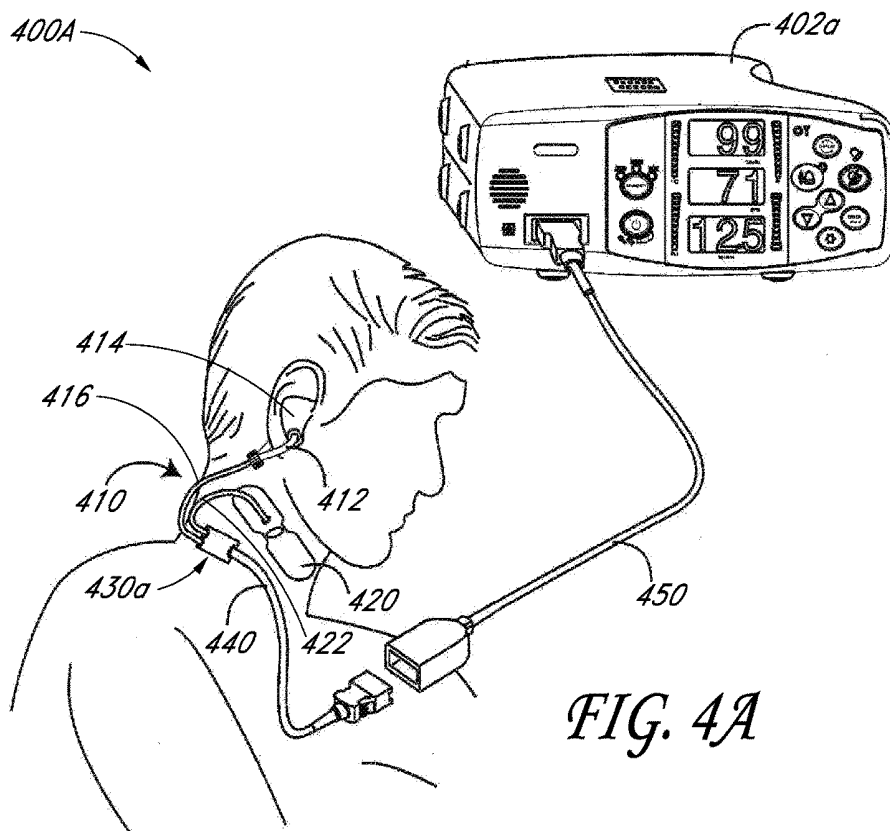

FIG. 4A

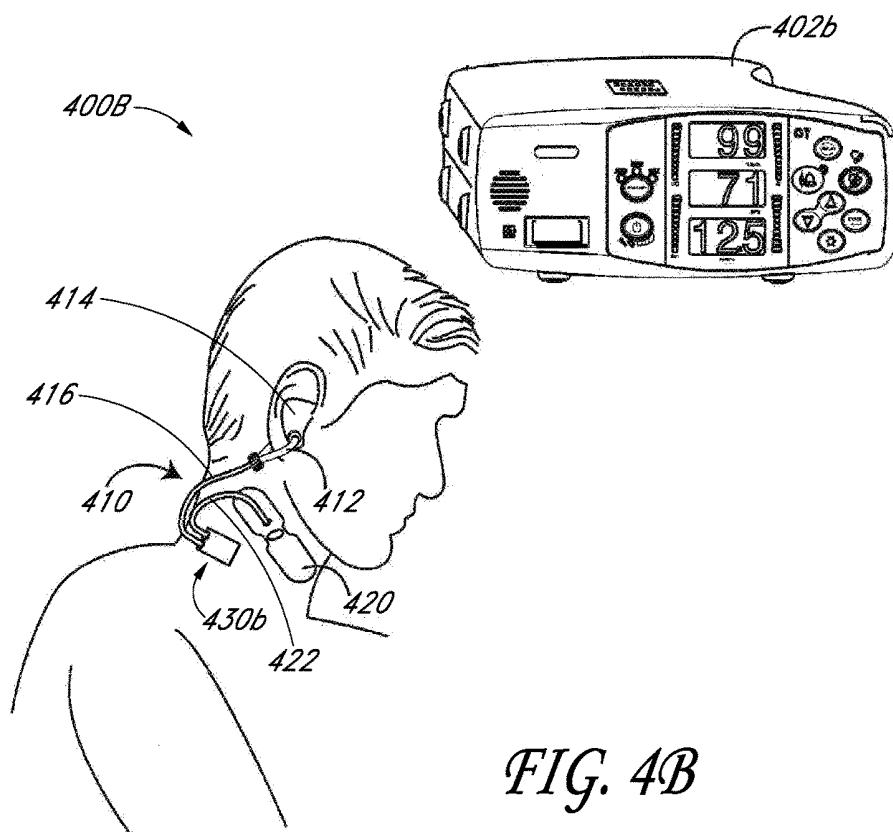

FIG. 4B

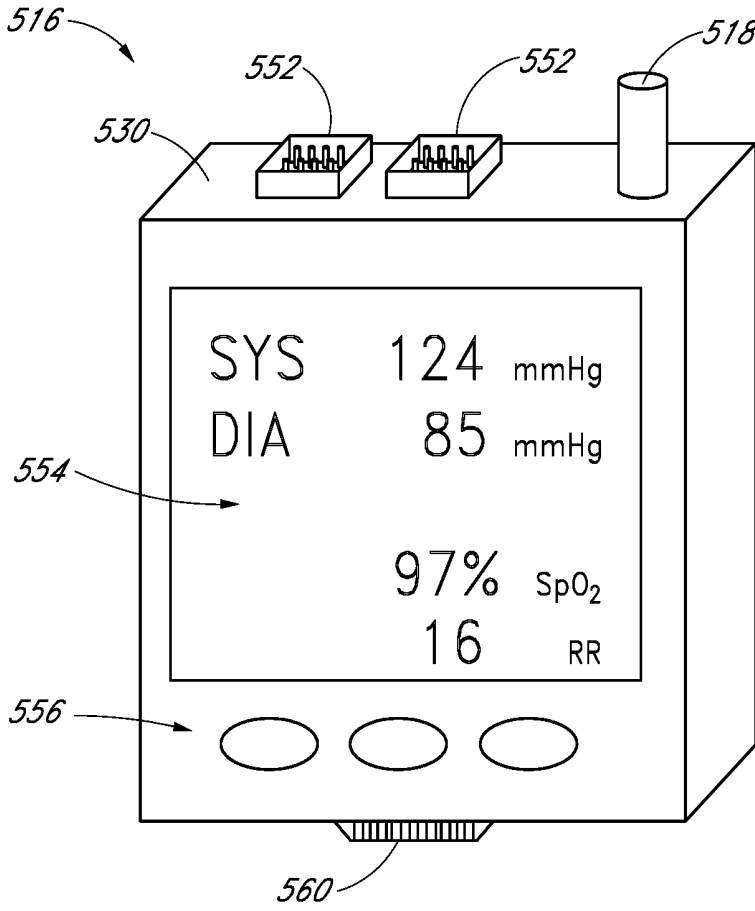

FIG. 5

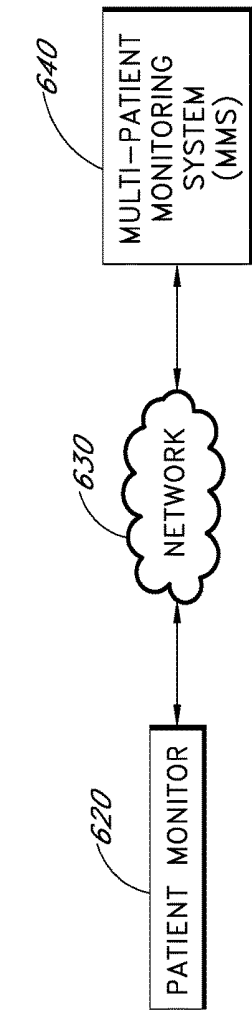

FIG. 6A

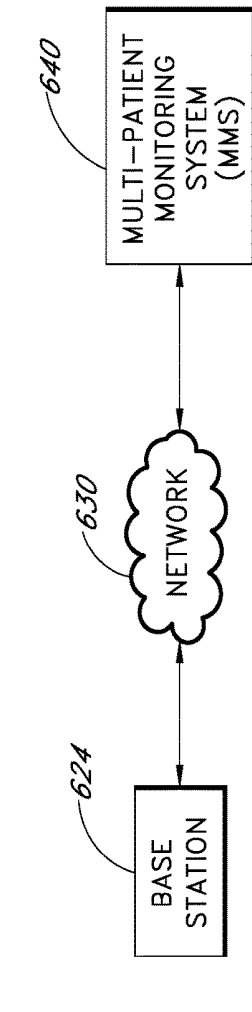

FIG. 6B

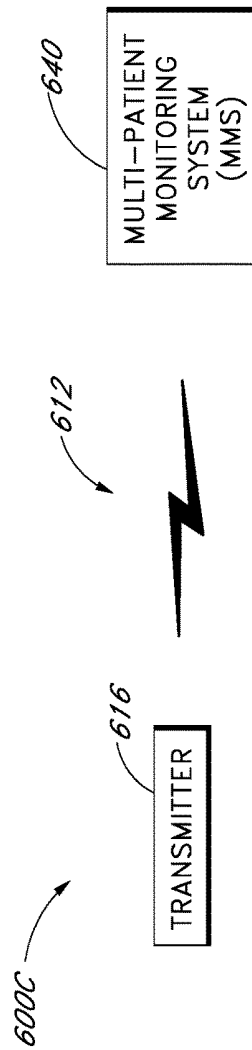

FIG. 6C

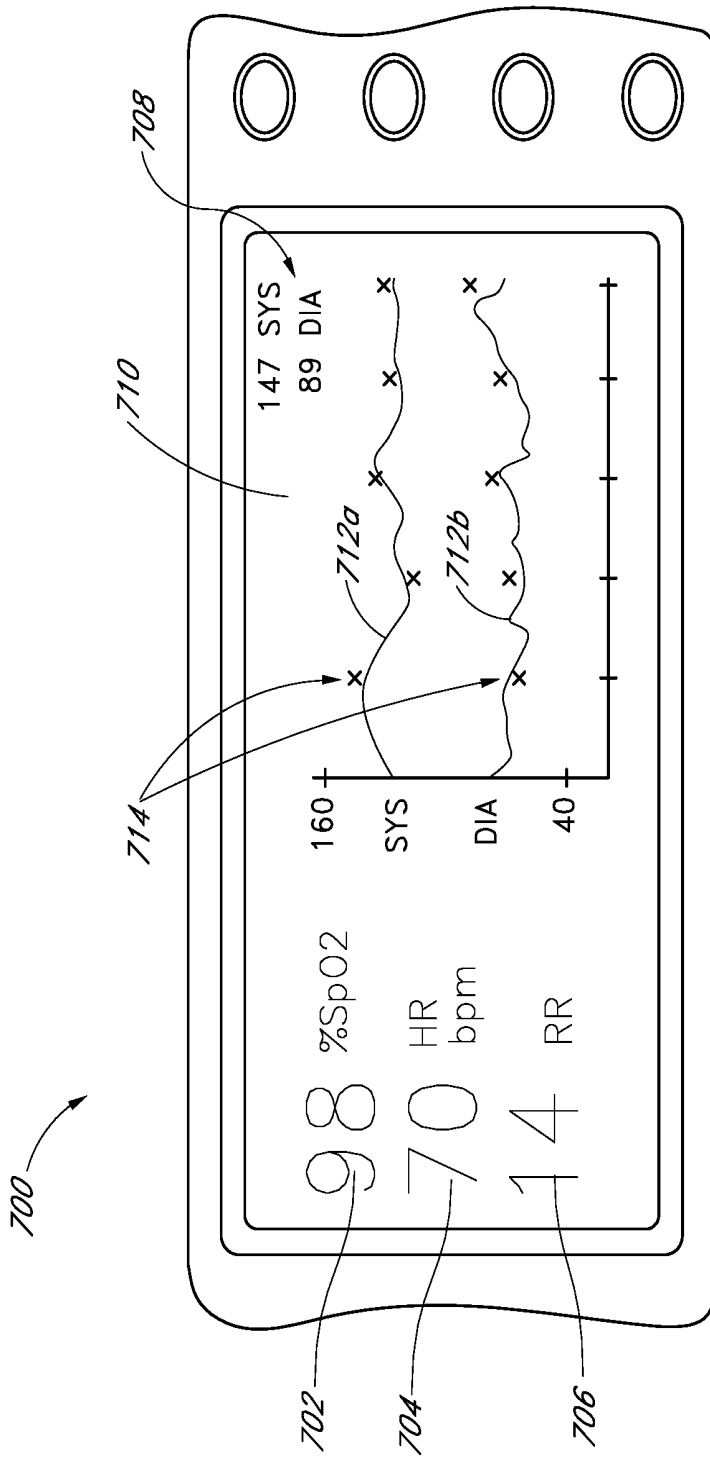

FIG. 7

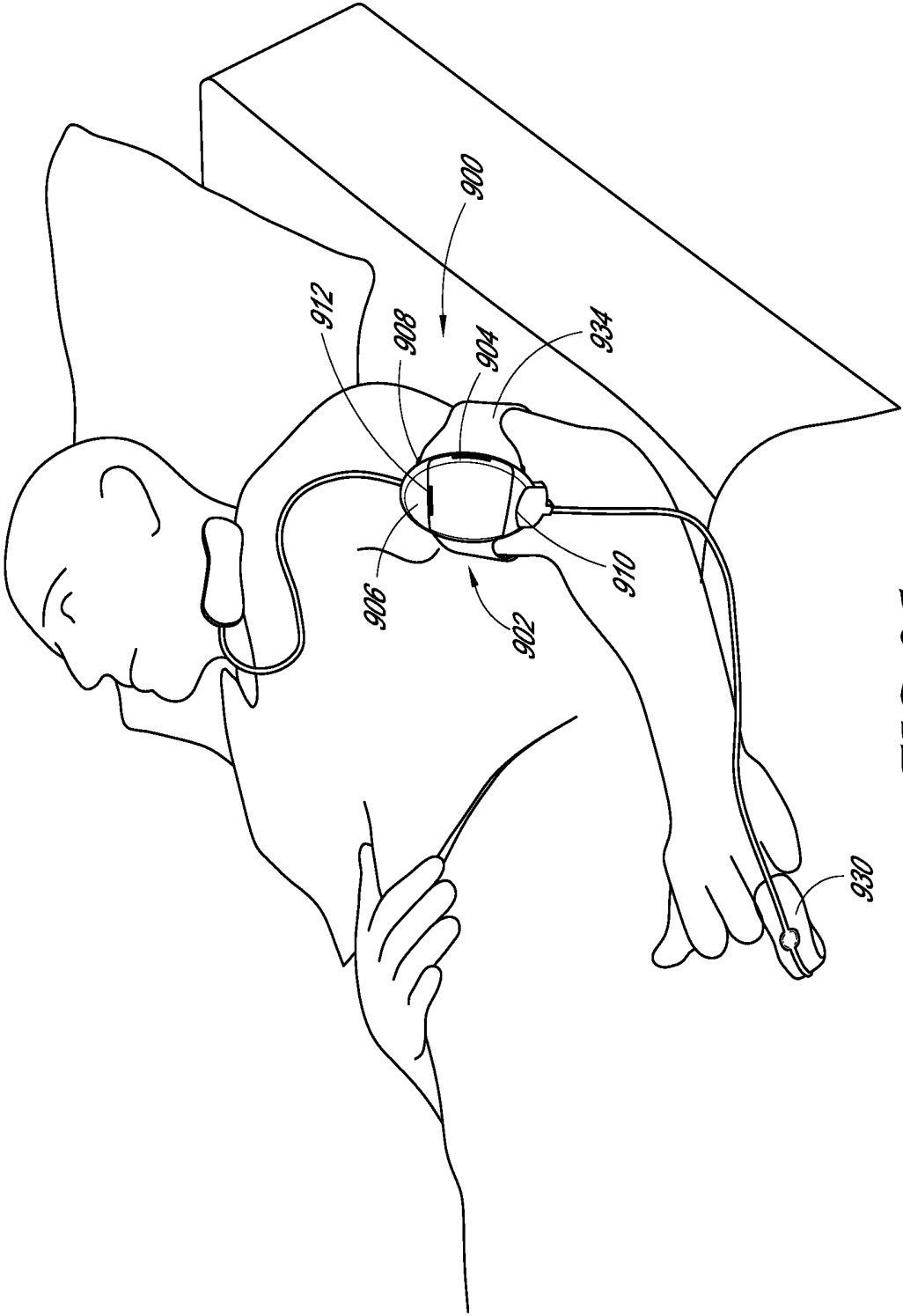

FIG. 9A

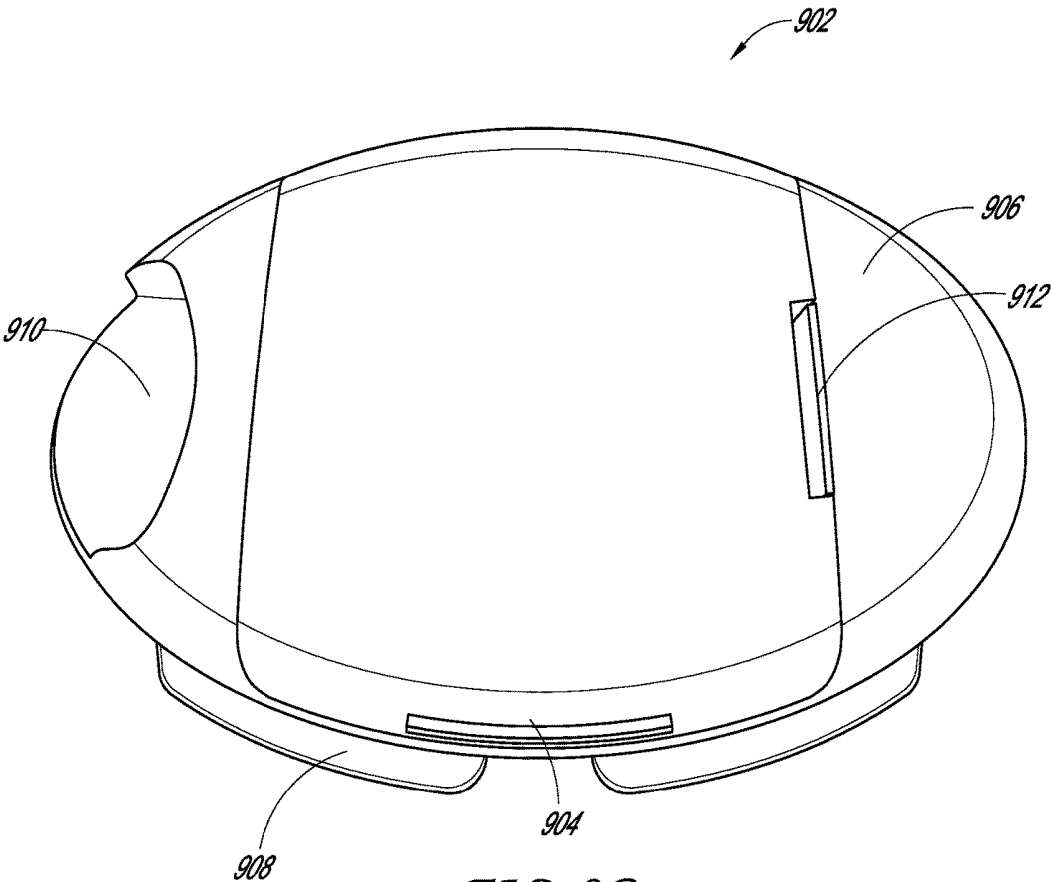

FIG. 9B

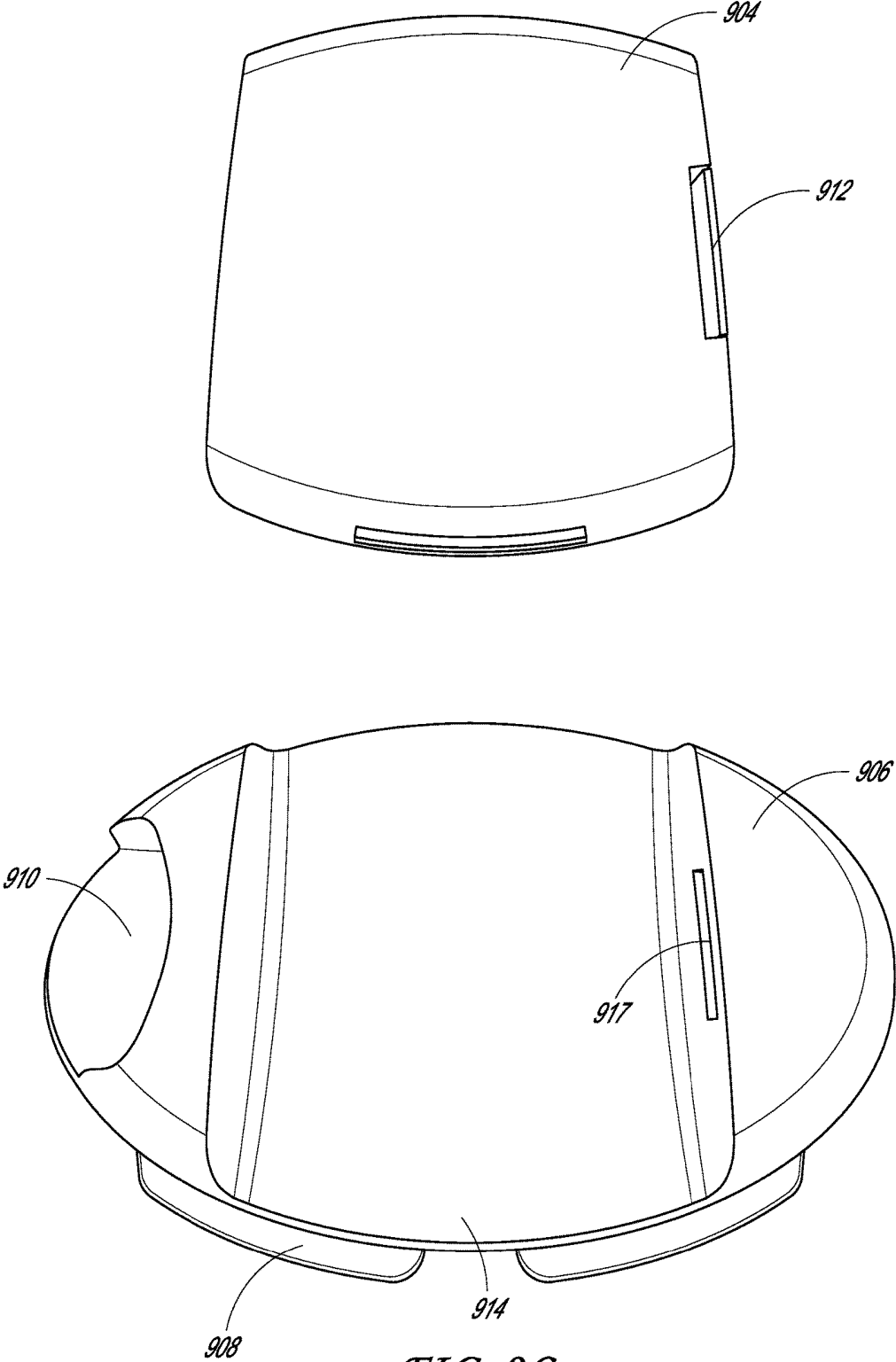

FIG. 9C

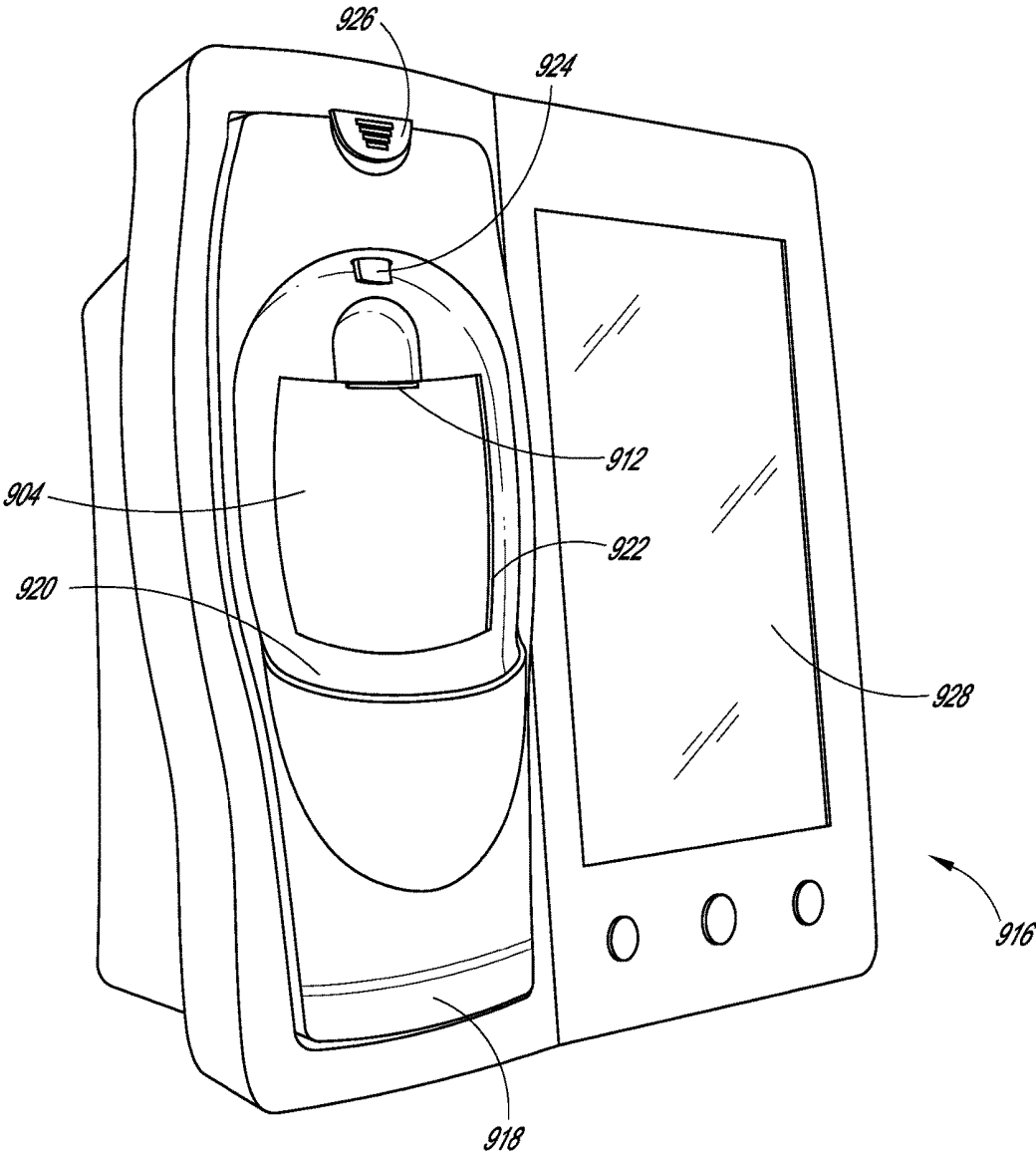

FIG. 9D

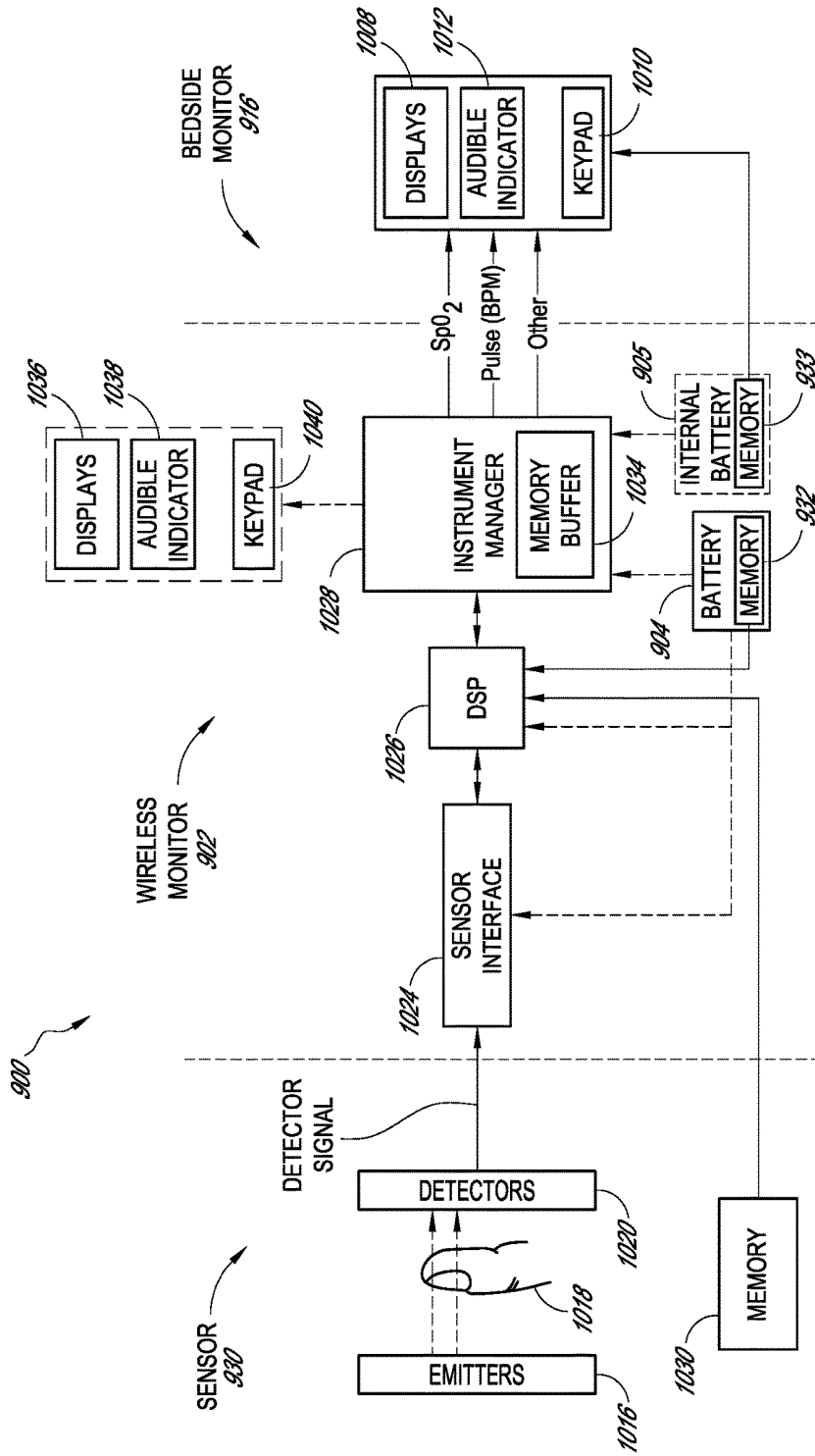

FIG. 10

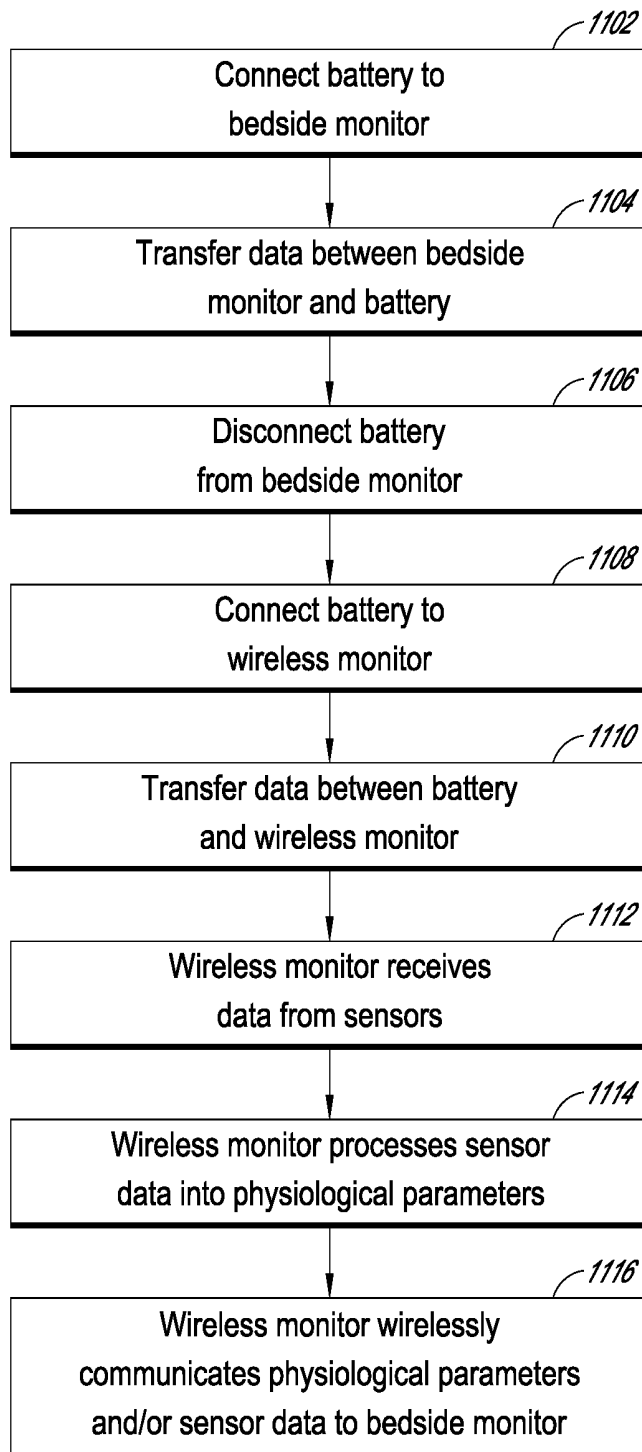

FIG. 11

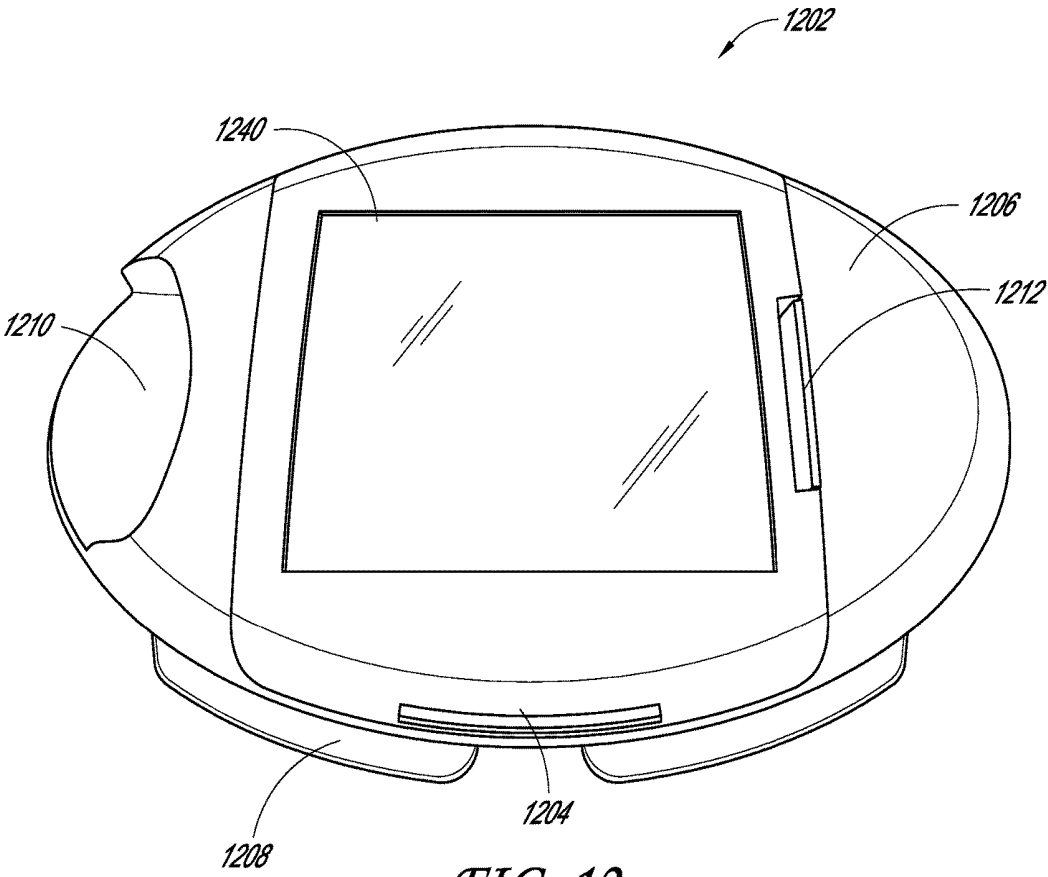

FIG. 12

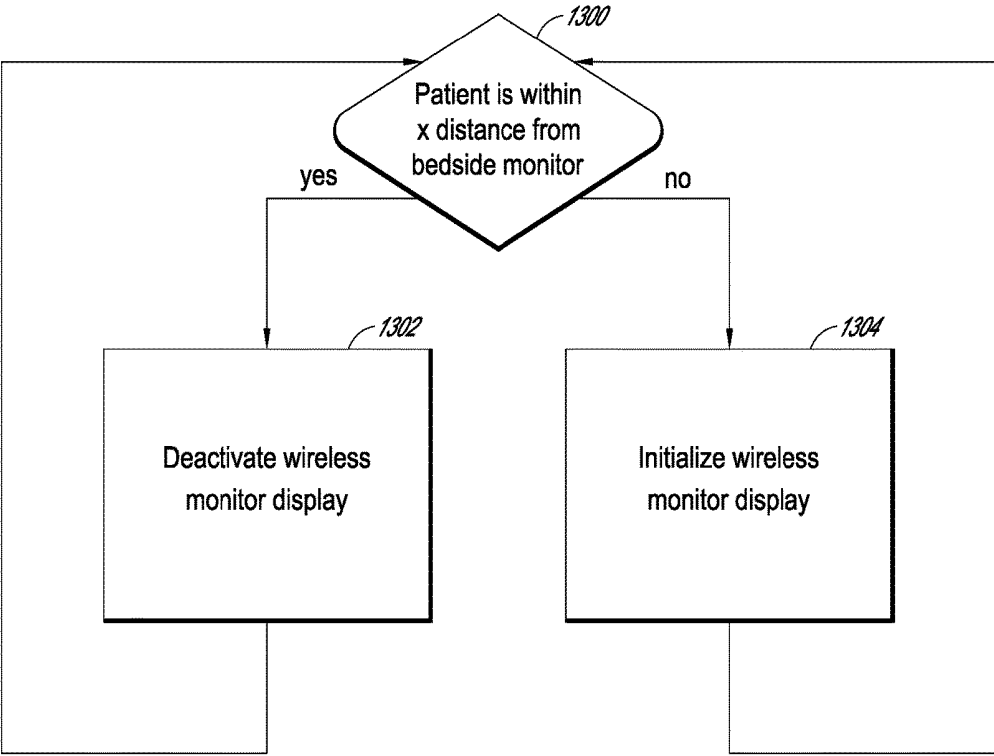

FIG. 13

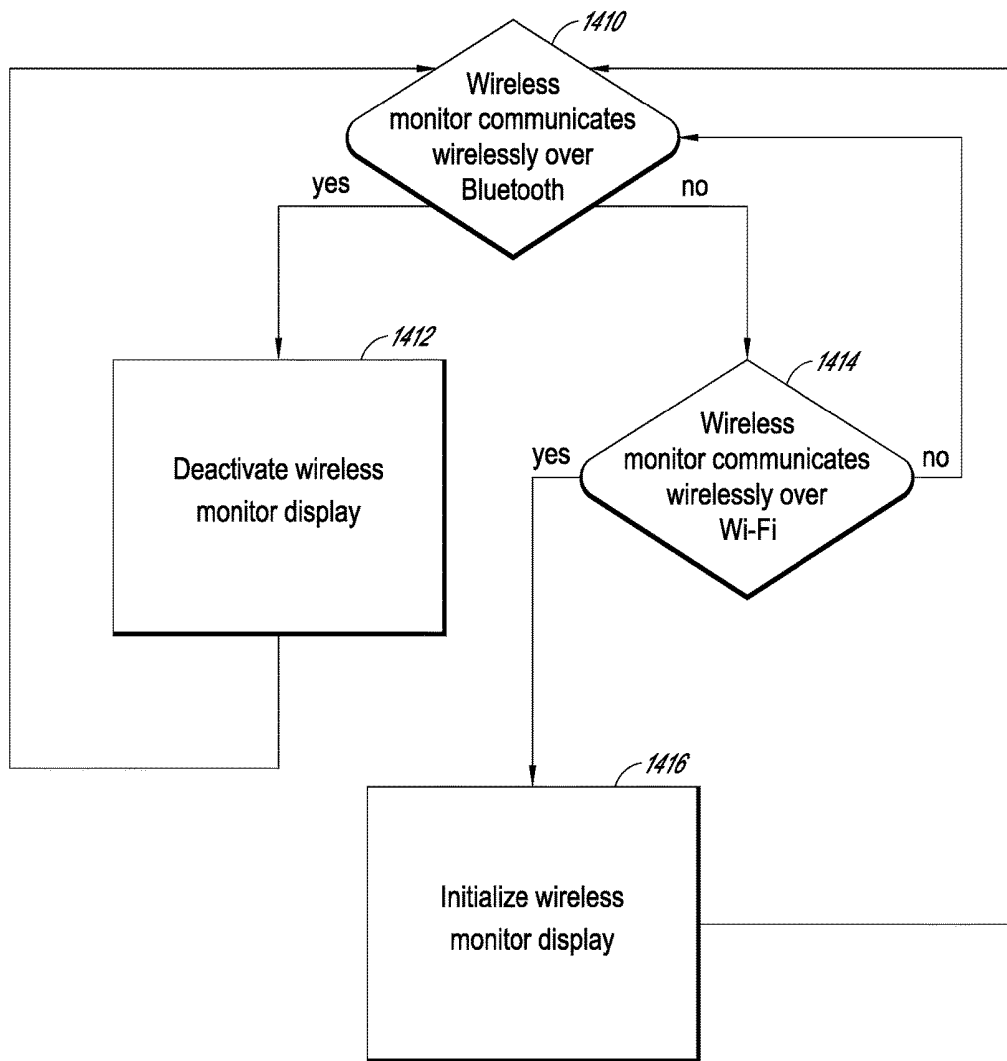

FIG. 14

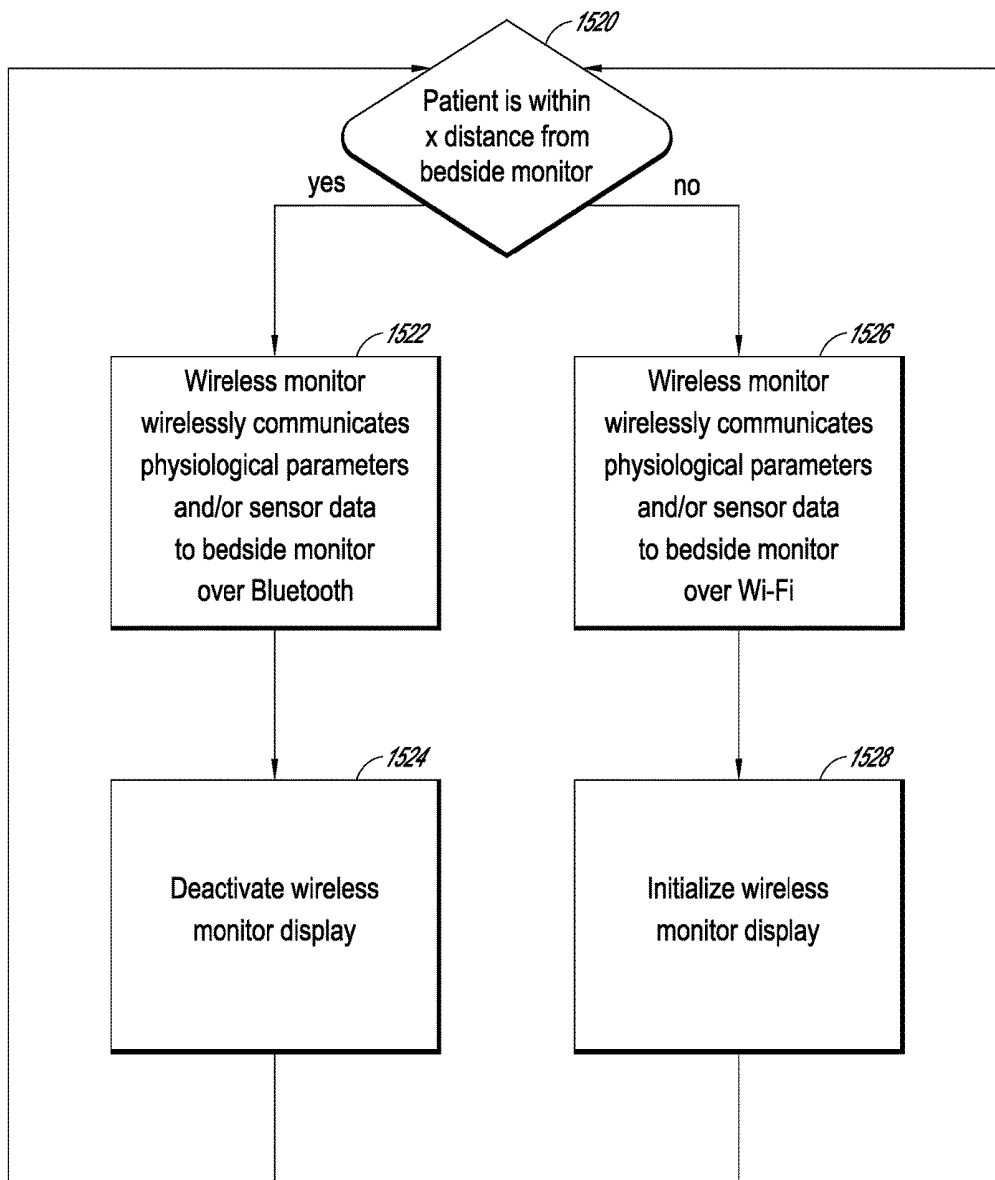

FIG. 15

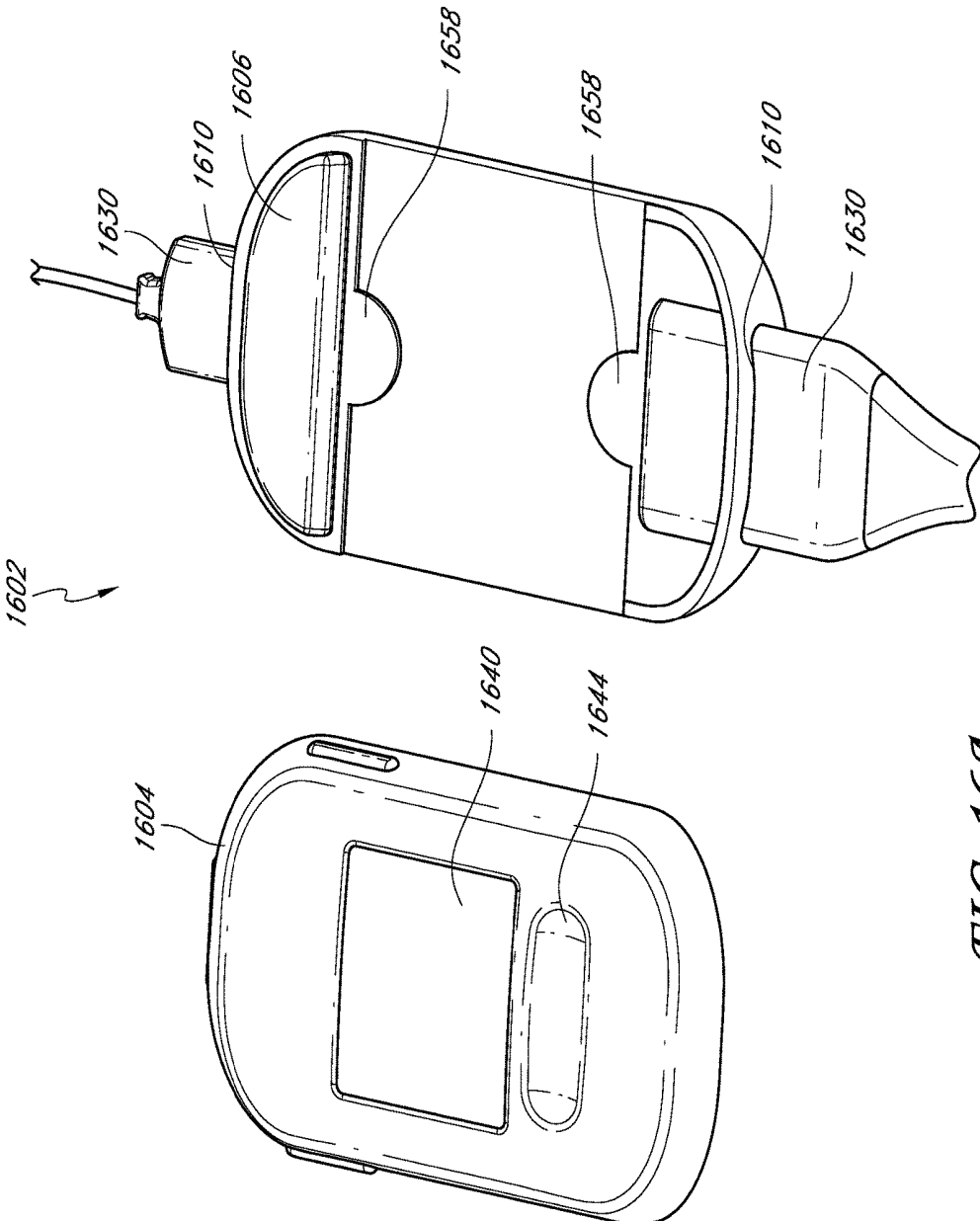

FIG. 16A

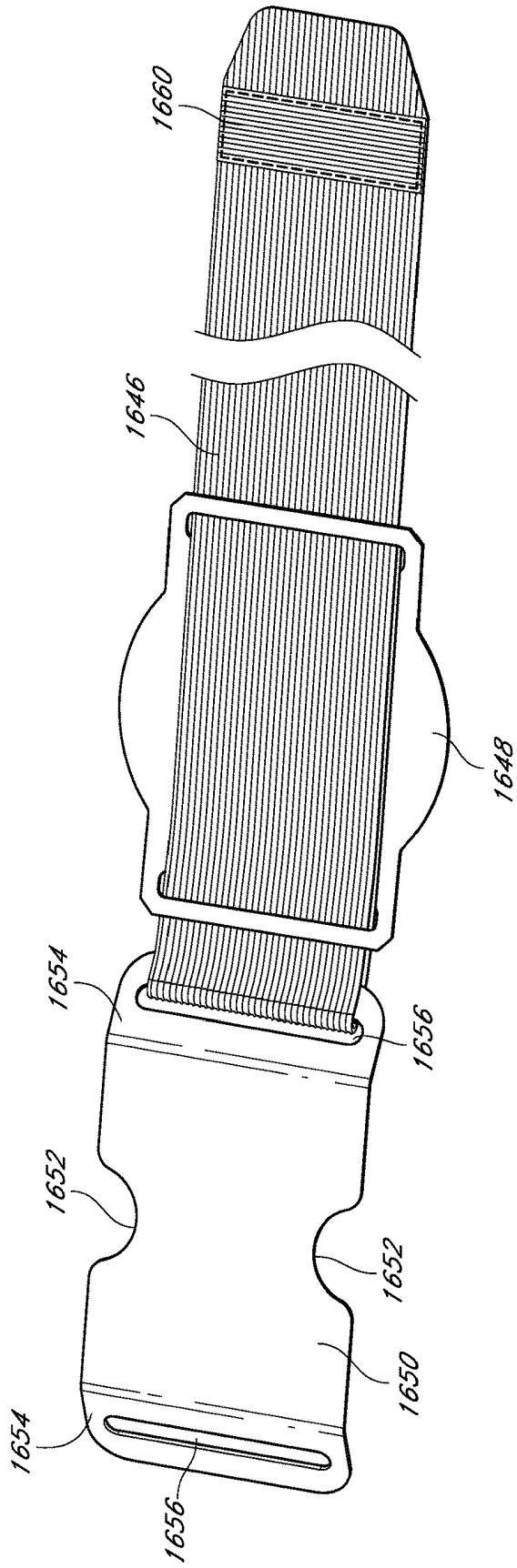

FIG. 16B

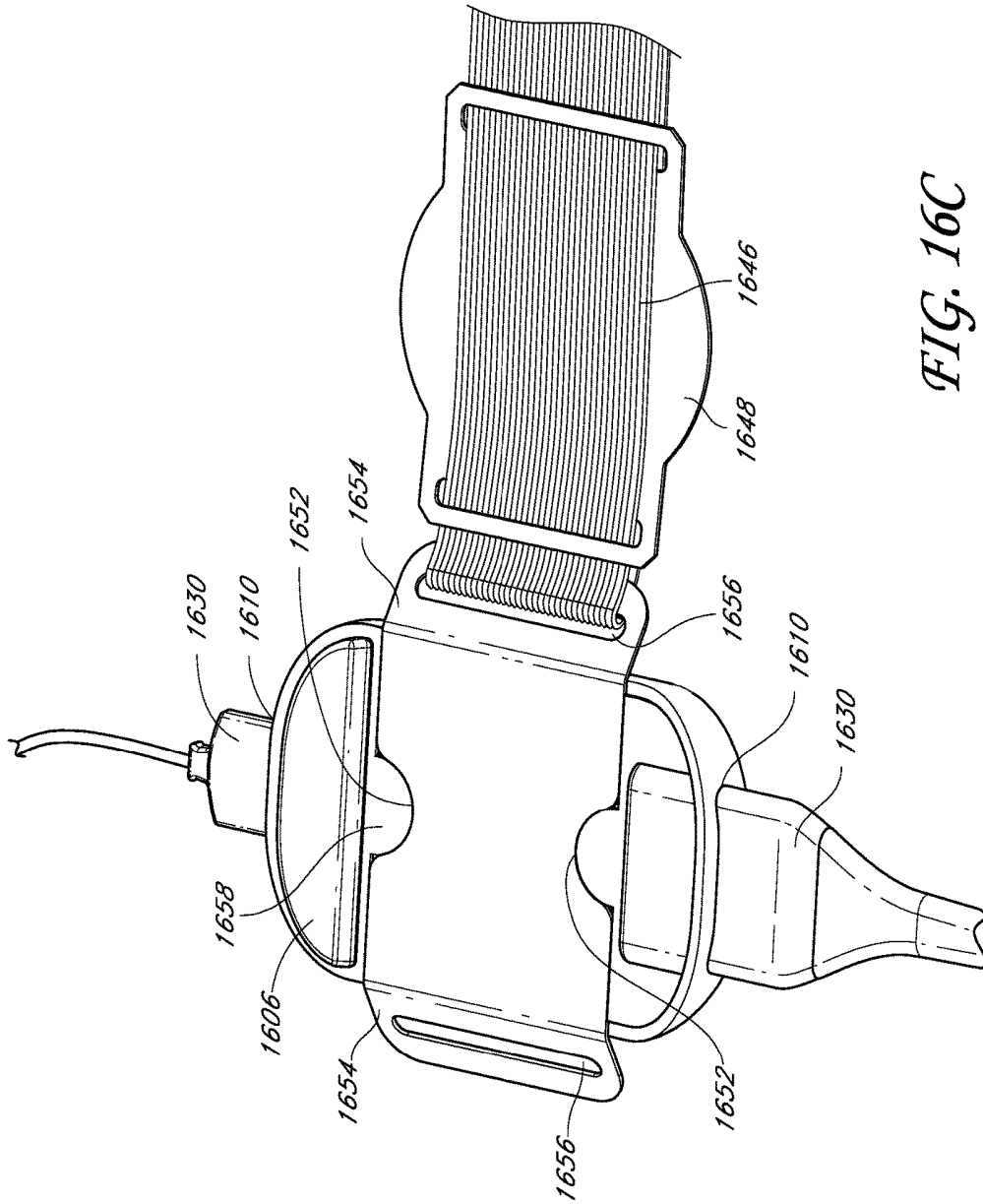

FIG. 16C

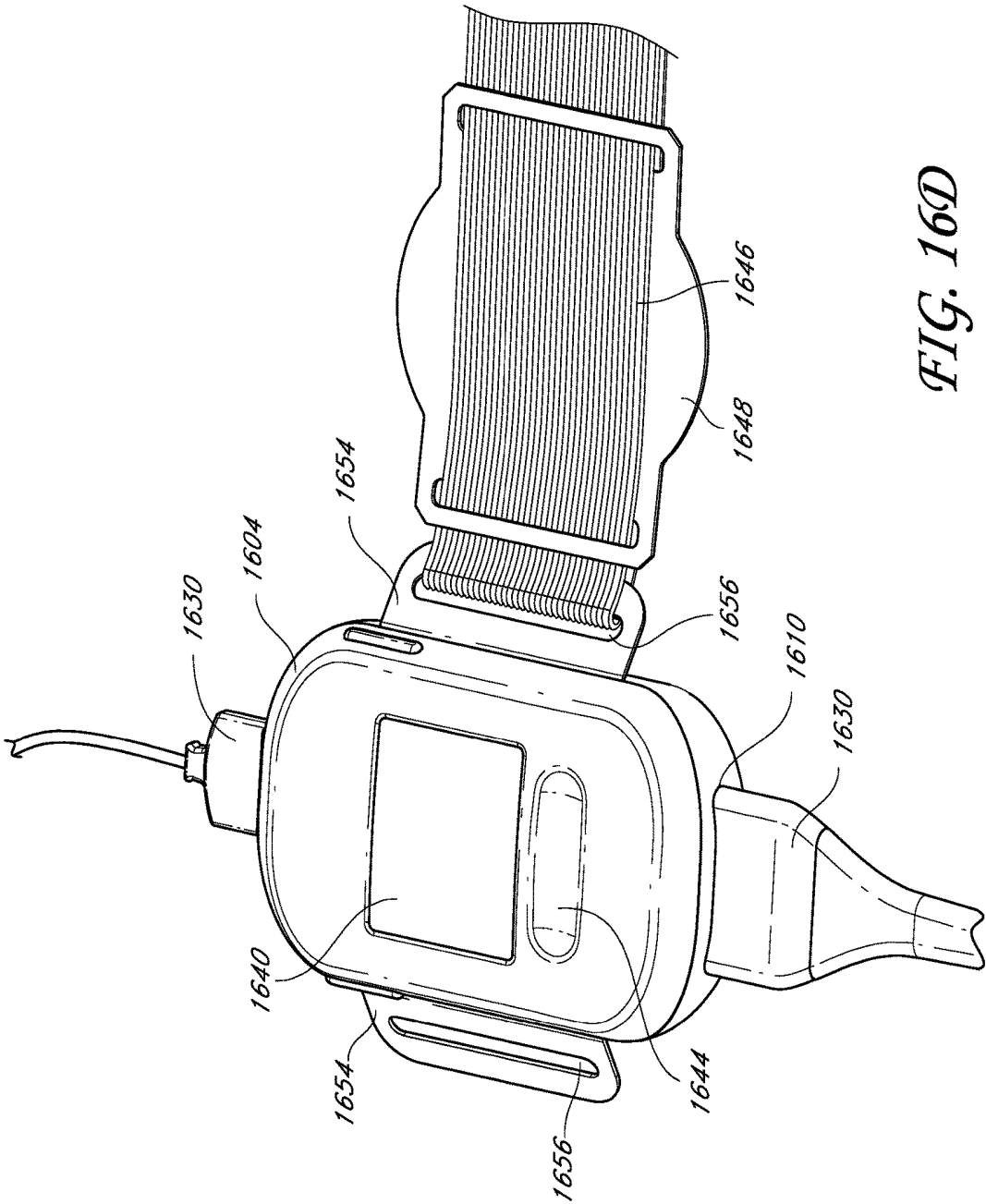

FIG. 16D

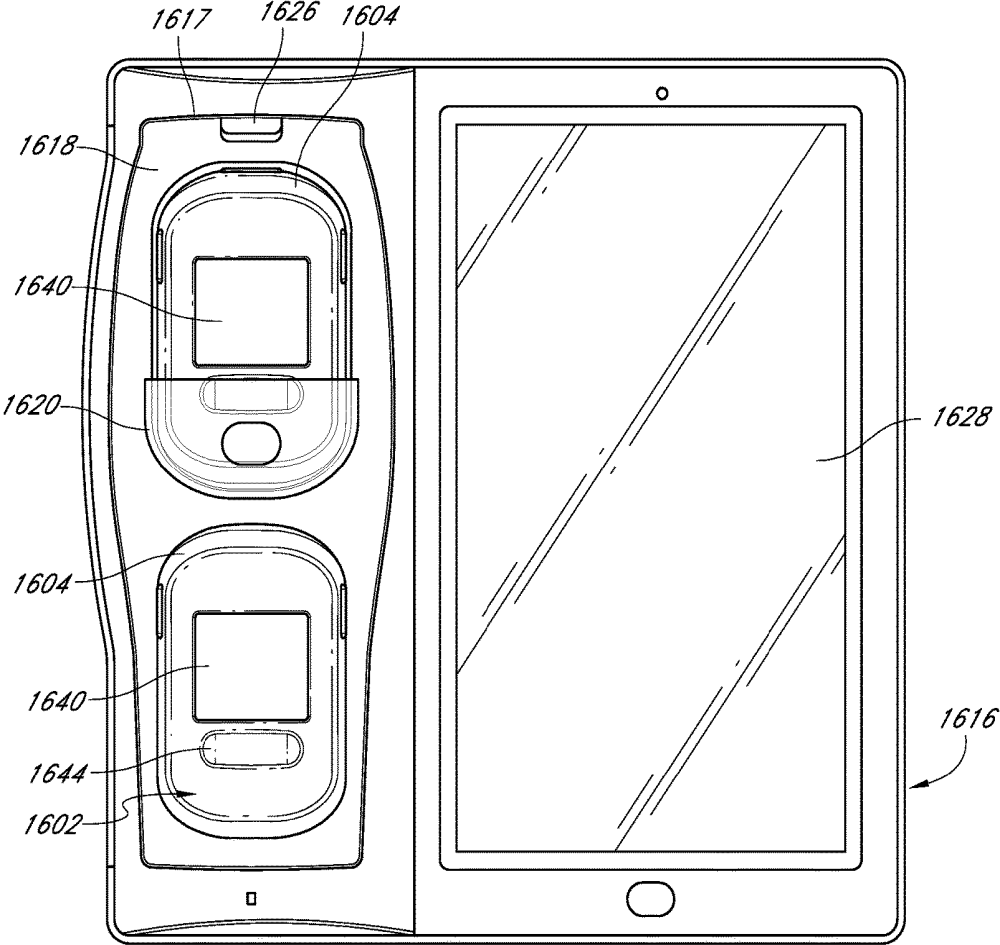

FIG. 16E

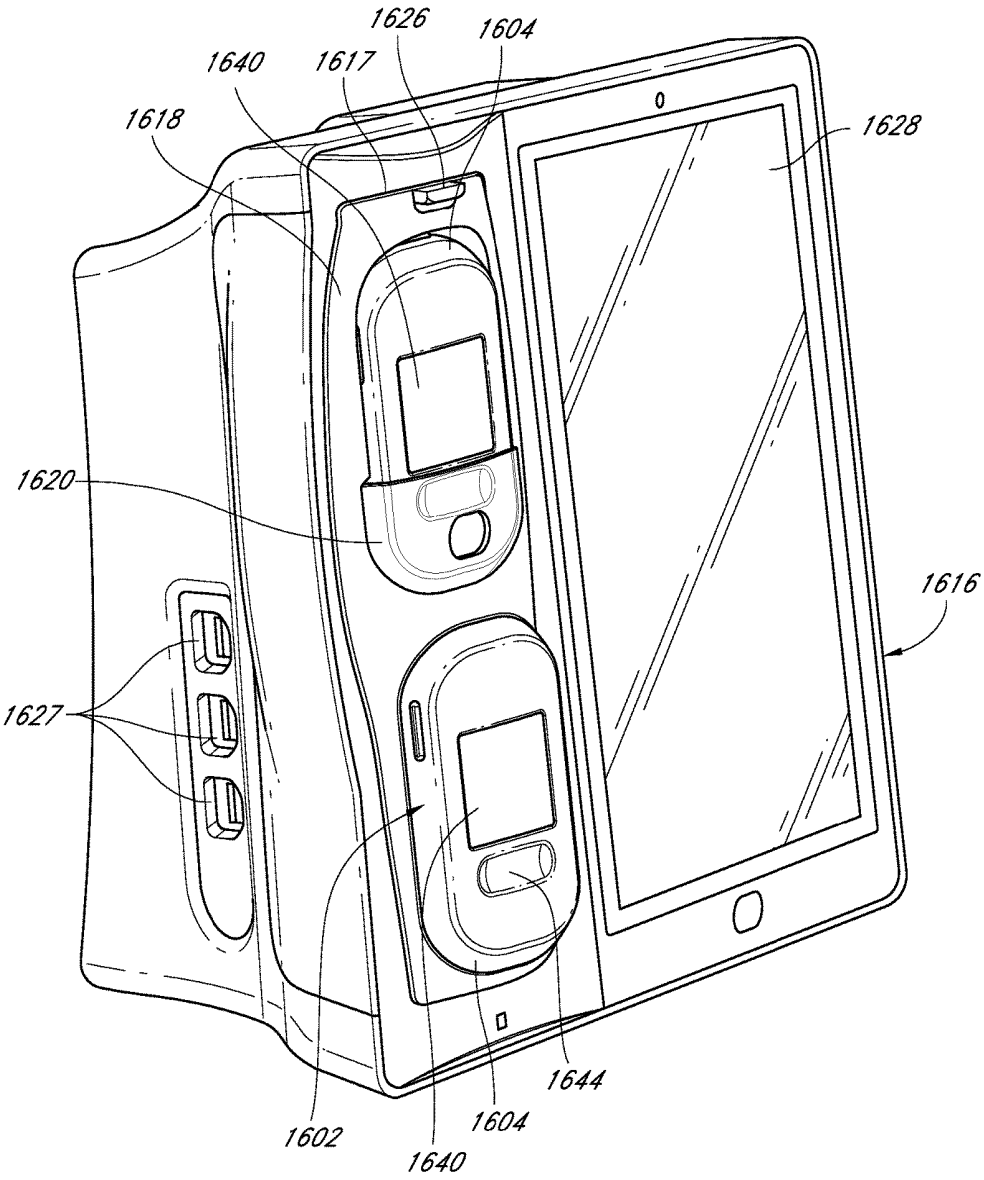

FIG. 16F

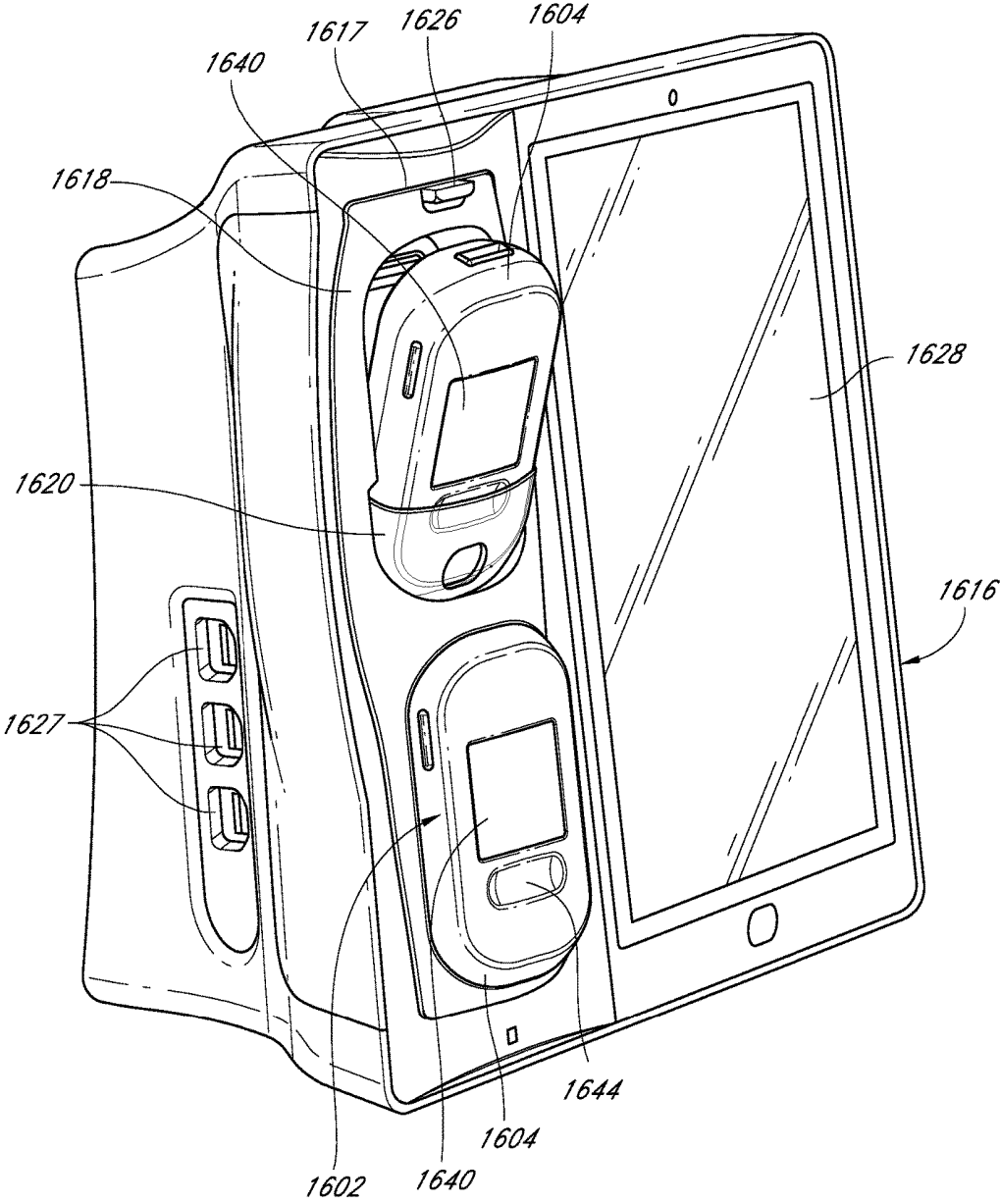

FIG. 16G

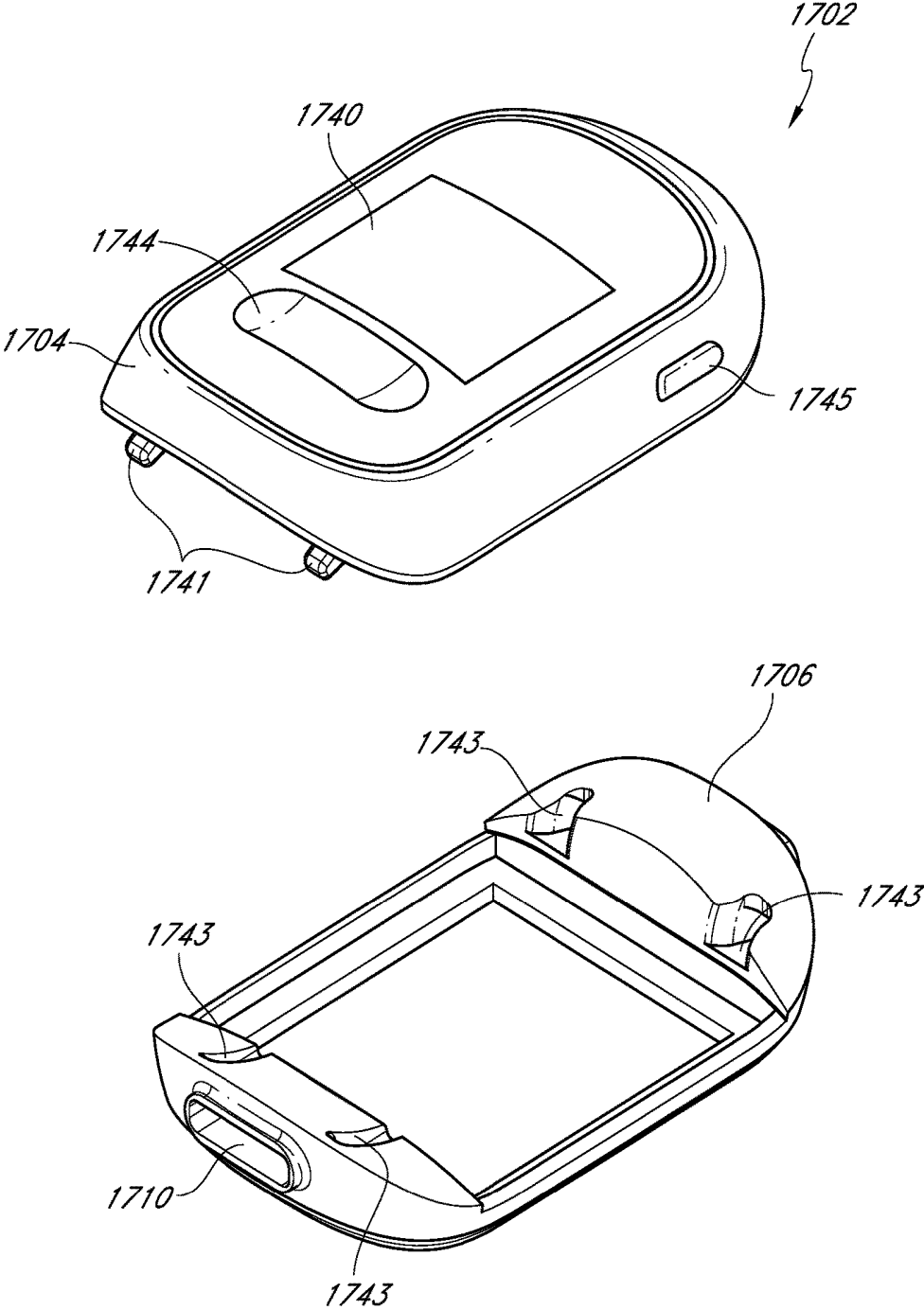

FIG. 17A

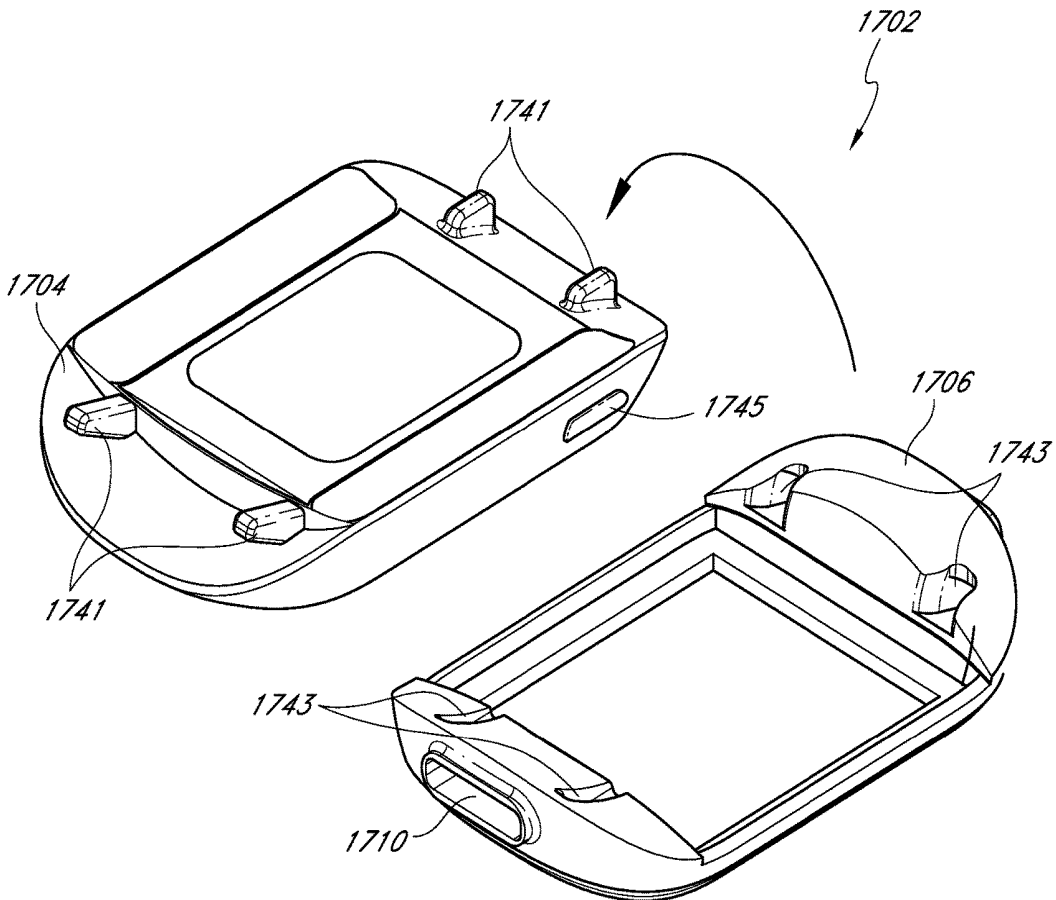

FIG. 17B

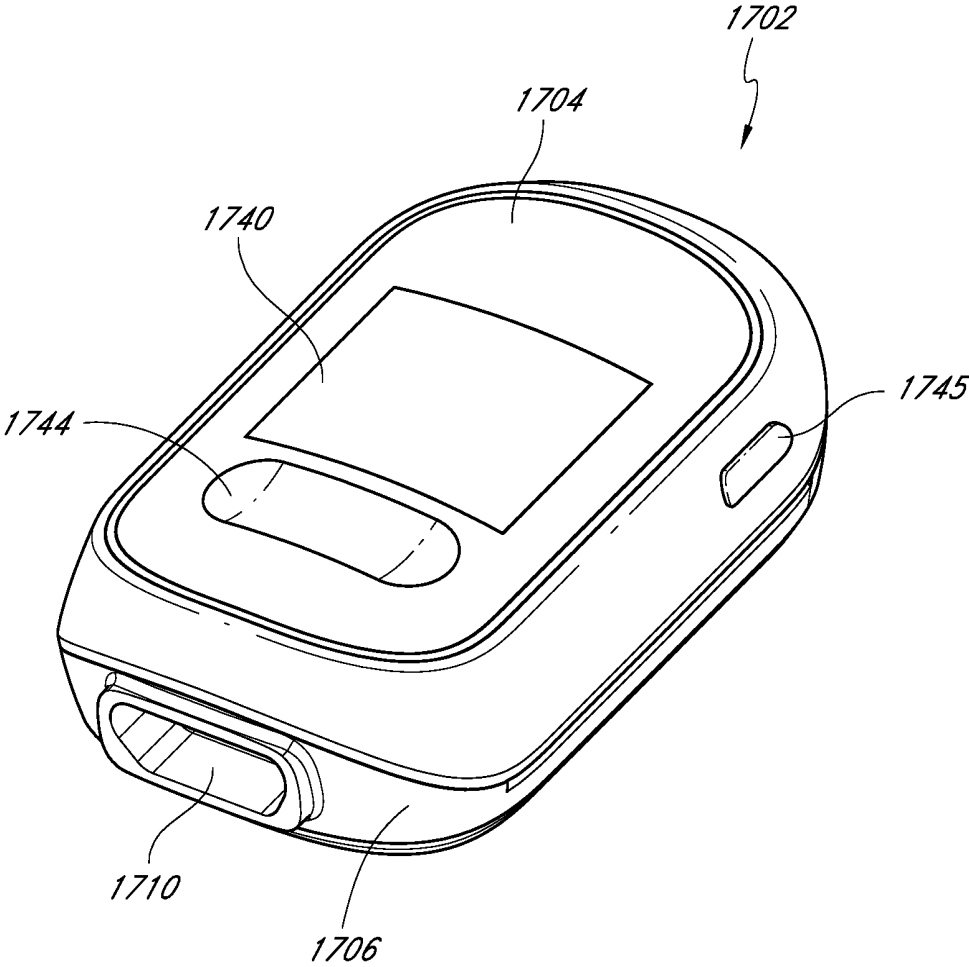

FIG. 17C

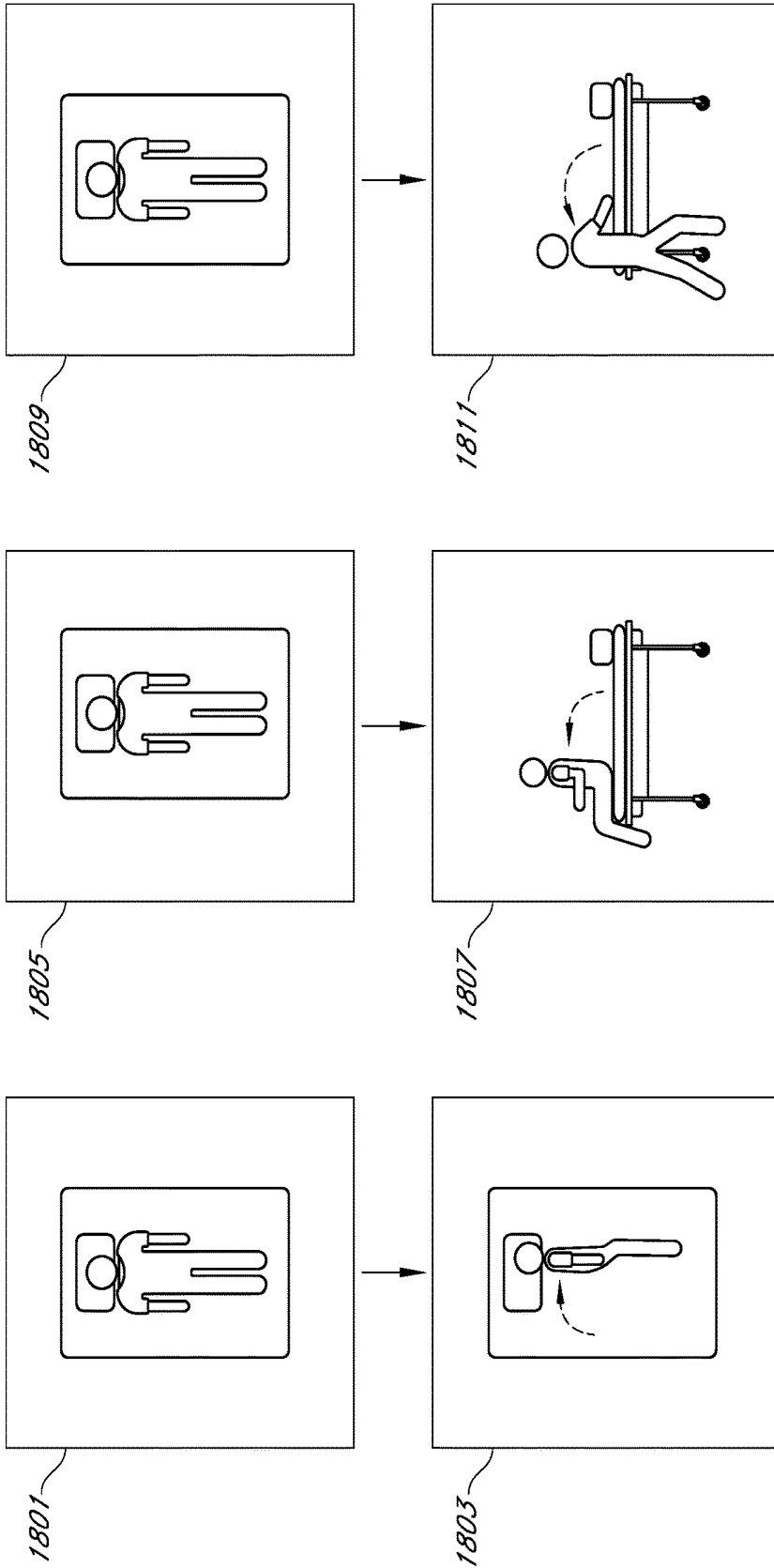

FIG. 18A

FIG. 18B

FIG. 18C

WIRELESS PATIENT MONITORING DEVICE

CROSS-REFERENCE TO RELATED APPLICATIONS

[0001] The present application is a continuation of U.S. patent application Ser. No. 13/762,270, now U.S. Pat. No. 10,149,616, filed Feb. 7, 2013, titled Wireless Patient Monitoring Device, which claims priority benefit under 35 U.S.C. § 119(e) to U.S. Provisional Patent Application Ser. No. 61/597,126, filed Feb. 9, 2012, titled Wireless Patient Monitoring System, U.S. Provisional Patent Application Ser. No. 61/625,584, filed Apr. 17, 2012, titled Wireless Patient Monitoring Device, and U.S. Provisional Patent Application Ser. No. 61/703,713, filed Sep. 20, 2012, titled Wireless Patient Monitoring Device, all of which applications are hereby incorporated by reference in their entirety.

BACKGROUND

Field

[0002] In general, the disclosure relates to methods and apparatuses for wirelessly monitoring a patient's physiological information.

Description of the Related Art

[0003] Hospitals, nursing homes, and other patient care facilities typically include patient monitoring devices at one or more bedsides in the facility. Patient monitoring devices generally include sensors, processing equipment, and displays for obtaining and analyzing a medical patient's physiological parameters such as blood oxygen saturation level, respiratory rate, and the like. Clinicians, including doctors, nurses, and other medical personnel, use the physiological parameters obtained from patient monitors to diagnose illnesses and to prescribe treatments. Clinicians also use the physiological parameters to monitor patients during various clinical situations to determine whether to increase the level of medical care given to patients.

[0004] For example, the patient monitoring devices can be used to monitor a pulse oximeter. Pulse oximetry is a widely accepted noninvasive procedure for measuring the oxygen saturation level of arterial blood, an indicator of a person's oxygen supply. A typical pulse oximetry system utilizes an optical sensor clipped onto a fingertip to measure the relative volume of oxygenated hemoglobin in pulsatile arterial blood flowing within the fingertip. Oxygen saturation (SpO_2), pulse rate, a plethysmograph waveform, perfusion index (PI), pleth variability index (PVI), methemoglobin (MetHb), carboxyhemoglobin (CoHb), total hemoglobin (tHb), glucose, and/or otherwise can be displayed on a monitor accordingly.

[0005] The patient monitoring devices can also communicate with an acoustic sensor comprising an acoustic transducer, such as a piezoelectric element. The acoustic sensor can detect respiratory and other biological sounds of a patient and provide signals reflecting these sounds to a patient monitor. An example of such an acoustic sensor, which can implement any of the acoustic sensing functions described herein, is described in U.S. application Ser. No. 12/643,939, filed Dec. 21, 2009, titled "Acoustic Sensor Assembly," and in U.S. Application No. 61/313,645, filed Mar. 12, 2010, titled "Acoustic Respiratory Monitoring

Sensor Having Multiple Sensing Elements," the disclosures of which are hereby incorporated by reference in their entirety.

[0006] Blood pressure is another example of a physiological parameter that can be monitored. Many devices allow blood pressure to be measured by sphygmomanometer systems that utilize an inflatable cuff applied to a person's arm. The cuff is inflated to a pressure level high enough to occlude a major artery. When air is slowly released from the cuff, blood pressure can be estimated by detecting "Korotkoff" sounds using a stethoscope or other detection means placed over the artery. Other Examples of physiological parameters that can be measured include respiration rate, blood analyte measurements, such as oxygen saturation, and ECG.

SUMMARY

[0007] One aspect of the disclosure is a wireless patient monitoring device including one or more sensors configured to obtain physiological information. The one or more sensors can include an optical sensor, an acoustic respiratory sensor, and/or a blood pressure measurement device. Other sensors, including but not limited to, an EEG, ECG, and/or a sedation state sensor can also be used with the present disclosure. The one or more sensors are connected to a wireless monitor configured to receive the sensor data and to wirelessly transmit sensor data or physiological parameters reflective of the sensor data to a bedside monitor. The bedside monitor can be configured to output the physiological parameters, communication channel, and/or communication status.

[0008] Another aspect of the disclosure is directed toward a system configured to wirelessly communicate physiological information, the system including a battery, a housing, a rechargeable electrical storage module, and a memory module configured to store wireless communication information.

[0009] In some aspects of the disclosure, the wireless communication information stored on the data storage component facilitates communication between the wireless monitor and the bedside monitor. The information may be a unique identifier used to pair the wireless monitor with the bedside monitor. The information may be a password used to make sure only the correct receiver has access to the transmitted physiological data. The information may be channel information to make certain the wireless monitor and bedside monitor communicate on the same channel.

[0010] In some aspects of the disclosure, the bedside monitor can be configured to receive and recharge the removable battery. The battery may include a data storage component configured to store wireless communication information. In some embodiments, the bedside monitor communicates wireless communication information to the battery through a hard wired connection, and the battery stores the information. In some embodiments, the battery communicates wireless communication information to the bedside monitor through a hard wired connection.

[0011] Another aspect of the disclosure is directed toward a bedside monitor configured to receive the wireless monitor. In some embodiments, the bedside monitor communicates wireless communication information to the wireless monitor when the wireless monitor is physically and electrically connected with the bedside monitor. In some embodiments, the wireless monitor communicates informa-

tion to the bedside monitor when the wireless monitor is physically and electrically connected with the bedside monitor.

[0012] In another aspect of the disclosure, the wireless monitor can be configured to transmit physiological data over a first wireless technology when a signal strength of the first wireless technology is sufficiently strong and transmit physiological data over a second wireless technology when the signal strength of the first wireless technology is not sufficiently strong.

[0013] In yet another aspect of the disclosure, the wireless monitor can be configured to transmit physiological data over a first wireless technology when the wireless monitor is within a pre-determined distance from the wireless receiver and transmit physiological data over a second wireless technology when the wireless monitor is not within a pre-determined distance from the bedside monitor.

[0014] In another aspect of the disclosure, the battery includes a display. The display can be configured to activate when the wireless transmitter transmits physiological data over a first wireless technology and deactivate when the wireless transmitter transmits physiological data over a second wireless technology.

[0015] One aspect of the disclosure is a method of wirelessly monitoring physiological information. The method includes providing a battery including a data storage component, physically connecting the battery to a bedside monitor, storing data on the data storage component of the battery, connecting the battery to a wireless monitor, and transmitting physiological data from the wireless monitor to the bedside monitor.

[0016] In another aspect of the disclosure, transmitting physiological data from the wireless monitor to the bedside monitor includes transmitting physiological data over a first wireless technology when the wireless monitor is within a pre-determined distance from the bedside monitor and transmitting physiological data over a second wireless technology when the wireless monitor is not within a pre-determined distance from the bedside monitor. In some embodiments of the disclosure, the first wireless technology is Bluetooth or ZigBee, and the second wireless technology is Wi-Fi or cellular telephony.

[0017] In yet another aspect of the disclosure, transmitting physiological data from the wireless monitor to the bedside monitor includes transmitting physiological data over a first wireless technology when a signal strength of the first wireless technology is sufficiently strong and transmitting physiological data over a second wireless technology when the signal strength of the first wireless technology is not sufficiently strong.

[0018] In some aspects of the disclosure, the wireless monitor can be configured to be coupled to an arm band attached to the patient. Alternatively, the wireless monitor can be configured to be coupled to a patient's belt, can be carried by the patient (e.g., via a shoulder strap or handle), or can be placed on the patient's bed next to the patient, among other locations.

[0019] In another aspect of the disclosure, the wireless monitor battery includes a display screen. When the wireless monitor is within a pre-determined distance from the bedside monitor and transmits data over Bluetooth or Zigbee, the display screen deactivates. When the wireless monitor is not within a pre-determined distance from the bedside monitor and transmits data over Wi-Fi or cellular telephony,

the display screen activates. Alternatively, independent of the communication protocol used by the device, when the wireless monitor is a pre-determined distance from the bedside monitor, the display screen activates. Similarly when the wireless monitor is within a pre-determined distance to the bedside monitor, the display screen deactivates.

[0020] In certain aspects of the disclosure, a blood pressure device can be used. The blood pressure device can be coupled to a medical patient and a wireless transceiver electrically coupled with the blood pressure device. The wireless transceiver can wirelessly transmit blood pressure data received by the blood pressure device and physiological data received from one or more physiological sensors coupled to the blood pressure device. To further increase patient mobility, in some embodiments, a single cable can be provided for connecting multiple different types of sensors together.

[0021] In certain aspects of the disclosure, a wireless patient monitoring device for measuring one or more parameters can be secured to an arm of the patient. For example, a wireless measurement device for measuring oxygen saturation and respiration rate can be secured to the arm of a patient. The wireless monitoring device can connect to an oximeter probe and an acoustic respiration probe. The monitor can have a display screen and/or can transmit wireless information to a bedside monitor. In an embodiment, a docking station can be provided for the wireless monitoring device to dock it to a docking station forming a bedside monitor.

[0022] In some aspects of the disclosure, the patient monitoring devices can be coupled to a blood pressure cuff and measure blood pressure.

[0023] In some aspects of the disclosure, the patient monitoring system can include a sensor configured to obtain physiological information, an anchor connected to the sensor, and a wireless transceiver connected to the anchor. A first cable can connect the sensor to the anchor and a second cable can connect the anchor to the wireless transceiver. In certain aspects, the anchor can adhere to the patient or be carried by the patient in any manner discussed herein.

[0024] In some aspects of the disclosure, the patient monitoring system can include one or more sensors configured to obtain physiological information and a wireless transceiver configured to receive the physiological information. The wireless transceiver can include a housing having a first side and a second side. At least one connector can be positioned on the first side and at least one connector can be positioned on the second side. In certain aspects, the first side of housing can be opposite the second side of the housing.

[0025] In some aspects of the disclosure, a docking station can include a bedside monitor having a docking port configured to receive a first patient monitor and a docking station adapter configured to adapt the docking port to receive a second patient monitor. The second patient monitor can be a different size than the first patient monitor. In certain aspects, the first patient monitor can communicate with the bedside monitor over a wired connection when the first patient monitor is connected to the docking port. In certain aspects, the second patient monitor can communicate with the bedside monitor over a wired connection when the second patient monitor is connected to the docking station adapter and the docking station adapter is connected to the docking port.

[0026] In some aspects of the disclosure, a patient monitoring system can include a first sensor, a second sensor, and a wireless patient monitor configured to receive physiological information from the first sensor and the second sensor. The patient monitoring system can include a single cable connecting the first sensor and the second sensor to the wireless patient monitor. In certain aspects, the single cable can include a first cable section connecting the wireless patient monitor and the first sensor and a second cable section connecting the first sensor and the second sensor. In certain aspects, the first sensor and the second sensor can be powered by a shared power line and/or can transmit signals over a shared signal line.

[0027] In some aspects of the disclosure, a patient monitoring system can include one or more sensors configured to obtain physiological information, a patient monitor configured to receive the physiological information, and a cable hub having one or more inlet connectors connected to the one or more sensors and an outlet connector connected to the patient monitor. In certain aspects, the one or more inlet connectors can be positioned on a first end of the cable hub and the outlet connector can be positioned on a second end of the cable hub, opposite the first end. In certain aspects, the patient monitor can include a wireless transceiver. In certain aspects, the patient monitor can be configured to be worn by the patient. In certain aspects, the cable hub can be configured to adhere to the patient. In certain aspects, a first cable extends from at least one of the one or more sensors to one of the one or more inlet connectors, and a second cable extends from the outlet connector to the patient monitor.

[0028] Some aspects of the disclosure describe a method of using a patient monitoring system. The method can include providing a wireless transceiver having a first end and a second end opposite the first end, a first connector positioned on the first end, and a second connector positioned on the second end. The method can include connecting a first end of a first cable to the first connector, and connecting a first end of a second cable to the second connector. In certain aspects, the method can include connecting a second end of the first cable to a first sensor. In certain aspects, the method can include connecting a second end of the second cable to a second sensor or a cable hub connected to one or more sensors. In certain aspects, the method can include connecting a third sensor and/or anchor to the second cable. In certain aspects, the method can include connecting a third cable to a third connector on the second end of the wireless transceiver.

[0029] Certain aspects of this disclosure are directed toward a wireless monitor including a housing, a battery, and a strap. The housing can include one or more outlets configured to receive one or more sensors. The battery can be configured to removably engage the housing. A portion of the strap can be disposed between the housing and the battery when the housing is engaged with the battery. In certain aspects, the portion of the strap disposed between the housing and the battery can be a separately formed component from a remainder of the strap. In certain aspects, the portion of the strap can include one or more mating features configured to mate with corresponding features of the housing. In certain aspects, the one or more mating features are flush with the corresponding features of the housing. In certain aspects, the housing can include a recessed portion for receiving the strap.

[0030] For purposes of summarizing the disclosure, certain aspects, advantages and novel features of the inventions have been described herein. It is to be understood that not necessarily all such advantages can be achieved in accordance with any particular embodiment of the inventions disclosed herein. Thus, the inventions disclosed herein can be embodied or carried out in a manner that achieves or optimizes one advantage or group of advantages as taught herein without necessarily achieving other advantages as can be taught or suggested herein.

BRIEF DESCRIPTION OF THE DRAWINGS

[0031] Various embodiments will be described hereinafter with reference to the accompanying drawings. These embodiments are illustrated and described by example only, and are not intended to limit the scope of the disclosure. In the drawings, similar elements have similar reference numerals.

[0032] FIGS. 1A and 1B illustrate embodiments of wireless patient monitoring systems.

[0033] FIGS. 1C and 1D illustrate further embodiments of wireless patient monitoring systems.

[0034] FIG. 1E illustrates the embodiment of the wireless patient monitoring system illustrated in FIGS. 1A-1B in schematic form.

[0035] FIGS. 2A and 2B illustrate embodiments of wireless patient monitoring systems having a single cable connection system.

[0036] FIGS. 3A and 3B illustrates additional embodiment of patient monitoring systems.

[0037] FIGS. 4A and 4B illustrate embodiments of an optical ear sensor and an acoustic sensor connected via a single cable connection system.

[0038] FIG. 5 illustrates an embodiment of a wireless transceiver that can be used with any of the patient monitoring systems described above.

[0039] FIGS. 6A through 6C illustrate additional embodiments of patient monitoring systems.

[0040] FIG. 7 illustrates an embodiment of a physiological parameter display that can be used with any of the patient monitoring systems described above.

[0041] FIG. 8 illustrates a further embodiment of a patient monitoring system.

[0042] FIGS. 9A-9D illustrate an embodiment of a wireless patient monitoring system.

[0043] FIG. 10 illustrates the embodiment of the wireless patient monitoring system illustrated in FIGS. 9A-9D in schematic form.

[0044] FIG. 11 illustrates one embodiment of a method of using a wireless patient monitoring system.

[0045] FIG. 12 illustrates a wireless monitor having a display screen.

[0046] FIGS. 13-15 illustrate methods of using a wireless monitor having a display screen.

[0047] FIGS. 16A-16G illustrate another embodiment of a wireless patient monitoring system.

[0048] FIGS. 17A-17C illustrate another embodiment of a wireless patient monitoring system.

[0049] FIGS. 18A-18C illustrate an animation of patient movement created using a wireless patient monitor.

DETAILED DESCRIPTION

[0050] In clinical settings, medical sensors are often attached to patients to monitor physiological parameters of the patients. Some examples of medical sensors include, but are not limited to, blood oxygen sensors, such as pulse oximetry sensors, acoustic respiratory sensors, EEGs, ECGs, blood pressure sensors, sedation state sensors, etc. Typically, each sensor attached to a patient is connected to a bedside monitoring device with a cable. The cables limit the patient's freedom of movement and impede a care providers access to the patient. The cables connecting the patient to the bedside monitoring device also make it more difficult to move the patient from room to room or switch to different bedside monitors.

[0051] This disclosure describes embodiments of wireless patient monitoring systems that include a wireless device coupled to a patient and to one or more sensors. In one embodiment, the wireless device transmits sensor data obtained from the sensors to a patient monitor. By transmitting the sensor data wirelessly, these patient monitoring systems can advantageously replace some or all cables that connect patients to bedside monitoring devices. To further increase patient mobility and comfort, in some embodiments, a single cable connection system is also provided for connecting multiple different types of sensors together.

[0052] These patient monitoring systems are primarily described in the context of an example blood pressure cuff that includes a wireless transceiver. The blood pressure cuff and/or wireless transceiver can also be coupled to additional sensors, such as optical sensors, acoustic sensors, and/or electrocardiograph sensors. The wireless transceiver can transmit blood pressure data and sensor data from the other sensors to a wireless receiver, which can be a patient monitor. These and other features described herein can be applied to a variety of sensor configurations, including configurations that do not include a blood pressure cuff. In an embodiment, an arm band without a blood pressure cuff can be used to secure a wireless patient monitor connected to various sensors.

[0053] FIGS. 1A and 1B illustrate embodiments of wireless patient monitoring systems 100A, 100B, respectively. In the wireless patient monitoring systems 100 shown, a blood pressure device 110 is connected to a patient 101. The blood pressure device 110 includes a wireless transceiver 116, which can transmit sensor data obtained from the patient 101 to a wireless transceiver 120. Thus, the patient 101 is advantageously not physically coupled to a bedside monitor in the depicted embodiment and can therefore have greater freedom of movement.

[0054] Referring to FIG. 1A, the blood pressure device 110a includes an inflatable cuff 112, which can be an oscillometric cuff that is actuated electronically (e.g., via intelligent cuff inflation and/or based on a time interval) to obtain blood pressure information. The cuff 112 is coupled to a wireless transceiver 116. The blood pressure device 110a is also coupled to a fingertip optical sensor 102 via a cable 107. The optical sensor 102 can include one or more emitters and detectors for obtaining physiological information indicative of one or more blood parameters of the patient 101. These parameters can include various blood analytes such as oxygen, carbon monoxide, methemoglobin, total hemoglobin, glucose, proteins, lipids, a percentage thereof (e.g., concentration or saturation), and the like. The optical sensor 102 can also be used to obtain a

photoplethysmograph, a measure of plethysmograph variability, pulse rate, a measure of blood perfusion, and the like.

[0055] Additionally, the blood pressure device 110a is coupled to an acoustic sensor 104a via a cable 105. The cable 105 connecting the acoustic sensor 104a to the blood pressure device 110 includes two portions, namely a cable 105a and a cable 105b. The cable 105a connects the acoustic sensor 104a to an anchor 104b, which is coupled to the blood pressure device 110a via the cable 105b. The anchor 104b can be adhered to the patient's skin to reduce noise due to accidental tugging of the acoustic sensor 104a.

[0056] The acoustic sensor 104a can be a piezoelectric sensor or the like that obtains physiological information reflective of one or more respiratory parameters of the patient 101. These parameters can include, for example, respiratory rate, inspiratory time, expiratory time, inspiration-to-expiration ratio, inspiratory flow, expiratory flow, tidal volume, minute volume, apnea duration, breath sounds, rales, rhonchi, stridor, and changes in breath sounds such as decreased volume or change in airflow. In addition, in some cases the respiratory sensor 104a, or another lead of the respiratory sensor 104a (not shown), can measure other physiological sounds such as heart rate (e.g., to help with probe-off detection), heart sounds (e.g., S1, S2, S3, S4, and murmurs), and changes in heart sounds such as normal to murmur or split heart sounds indicating fluid overload. In some implementations, a second acoustic respiratory sensor can be provided over the patient's 101 chest for additional heart sound detection. In one embodiment, the acoustic sensor 104 can include any of the features described in U.S. patent application Ser. No. 12/643,939, filed Dec. 21, 2009, titled "Acoustic Sensor Assembly," the disclosure of which is hereby incorporated by reference in its entirety.

[0057] The acoustic sensor 104 can be used to generate an exciter waveform that can be detected by the optical sensor 102 at the fingertip, by an optical sensor attached to an ear of the patient (see FIGS. 2A, 3), by an ECG sensor (see FIG. 2C), or by another acoustic sensor (not shown). The velocity of the exciter waveform can be calculated by a processor (such as a processor in the wireless transceiver 120, described below). From this velocity, the processor can derive a blood pressure measurement or blood pressure estimate. The processor can output the blood pressure measurement for display. The processor can also use the blood pressure measurement to determine whether to trigger the blood pressure cuff 112.

[0058] In another embodiment, the acoustic sensor 104 placed on the upper chest can be advantageously combined with an ECG electrode (such as in structure 208 of FIG. 2B), thereby providing dual benefit of two signals generated from a single mechanical assembly. The timing relationship from fiducial markers from the ECG signal, related cardiac acoustic signal and the resulting peripheral pulse from the finger pulse oximeters produces a transit time that correlates to the cardiovascular performance such as blood pressure, vascular tone, vascular volume and cardiac mechanical function. Pulse wave transit time or PWTT in currently available systems depends on ECG as the sole reference point, but such systems may not be able to isolate the transit time variables associated to cardiac functions, such as the pre-ejection period (PEP). In certain embodiments, the addition of the cardiac acoustical signal allows isolation of the cardiac functions and provides additional cardiac performance metrics. Timing calculations can be performed by the

processor in the wireless transceiver **120** or a in distributed processor found in an on-body structure (e.g., such as any of the devices herein or below: **112**, **210**, **230**, **402**, **806**).

[**0059**] In certain embodiments, the wireless patient monitoring system **100** uses some or all of the velocity-based blood pressure measurement techniques described in U.S. Pat. No. 5,590,649, filed Apr. 15, 1994, titled “Apparatus and Method for Measuring an Induced Perturbation to Determine Blood Pressure,” or in U.S. Pat. No. 5,785,659, filed Jan. 17, 1996, titled “Automatically Activated Blood Pressure Measurement Device,” the disclosures of which are hereby incorporated by reference in their entirety. An example display related to such blood pressure calculations is described below with respect to FIG. 7.

[**0060**] The wireless transceiver **116** can transmit data using any of a variety of wireless technologies, such as Wi-Fi (802.11x), Bluetooth (802.15.2), Zigbee (802.15.4), cellular telephony, infrared, RFID, satellite transmission, proprietary protocols, combinations of the same, and the like. The wireless transceiver **116** can perform solely telemetry functions, such as measuring and reporting information about the patient **101**. Alternatively, the wireless transceiver **116** can be a transceiver that also receives data and/or instructions, as will be described in further detail below.

[**0061**] The wireless transceiver **120** receives information from and/or sends information to the wireless transceiver **116** via an antenna **122**. In certain embodiments, the wireless transceiver **120** is a patient monitor. As such, the wireless transceiver **120** can include one or more processors that process sensor signals received from the wireless transceiver **116** corresponding to the sensors **102a**, **102b**, **104**, and/or **106** in order to derive any of the physiological parameters described above. The wireless transceiver **120** can also display any of these parameters, including trends, waveforms, related alarms, and the like. The wireless transceiver **120** can further include a computer-readable storage medium, such as a physical storage device, for storing the physiological data. The wireless transceiver **120** can also include a network interface for communicating the physiological data to one or more hosts over a network, such as to a nurse’s station computer in a hospital network.

[**0062**] Moreover, in certain embodiments, the wireless transceiver **116** can send raw data for processing to a central nurse’s station computer, to a clinician device, and/or to a bedside device (e.g., the transceiver **116**). The wireless transceiver **116** can also send raw data to a central nurse’s station computer, clinician device, and/or to a bedside device for calculation, which retransmits calculated measurements back to the blood pressure device **110** (or to the bedside device). The wireless transceiver **116** can also calculate measurements from the raw data and send the measurements to a central nurse’s station computer, to a pager or other clinician device, or to a bedside device (e.g., the transceiver **116**). Many other configurations of data transmission are possible.

[**0063**] In addition to deriving any of the parameters mentioned above from the data obtained from the sensors **102a**, **102b**, **104**, and/or **106**, the wireless transceiver **120** can also determine various measures of data confidence, such as the data confidence indicators described in U.S. Pat. No. 7,024, 233 entitled “Pulse oximetry data confidence indicator,” the disclosure of which is hereby incorporated by reference in its entirety. The wireless transceiver **120** can also determine a perfusion index, such as the perfusion index described in

U.S. Pat. No. 7,292,883 entitled “Physiological assessment system,” the disclosure of which is hereby incorporated by reference in its entirety. Moreover, the wireless transceiver **120** can determine a plethysmograph variability index (PVI), such as the PVI described in U.S. Publication No. 2008/0188760 entitled “Plethysmograph variability processor,” the disclosure of which is hereby incorporated by reference in its entirety.

[**0064**] In addition, the wireless transceiver **120** can send data and instructions to the wireless transceiver **116** in some embodiments. For instance, the wireless transceiver **120** can intelligently determine when to inflate the cuff **112** and can send inflation signals to the transceiver **116**. Similarly, the wireless transceiver **120** can remotely control any other sensors that can be attached to the transceiver **116** or the cuff **112**. The transceiver **120** can send software or firmware updates to the transceiver **116**. Moreover, the transceiver **120** (or the transceiver **116**) can adjust the amount of signal data transmitted by the transceiver **116** based at least in part on the acuity of the patient, using, for example, any of the techniques described in U.S. Patent Publication No. 2009/0119330, filed Jan. 7, 2009, titled “Systems and Methods for Storing, Analyzing, and Retrieving Medical Data,” the disclosure of which is hereby incorporated by reference in its entirety.

[**0065**] In alternative embodiments, the wireless transceiver **116** can perform some or all of the patient monitor functions described above, instead of or in addition to the monitoring functions described above with respect to the wireless transceiver **120**. In some cases, the wireless transceiver **116** might also include a display that outputs data reflecting any of the parameters described above (see, e.g., FIG. 5). Thus, the wireless transceiver **116** can either send raw signal data to be processed by the wireless transceiver **120**, can send processed signal data to be displayed and/or passed on by the wireless transceiver **120**, or can perform some combination of the above. Moreover, in some implementations, the wireless transceiver **116** can perform at least some front-end processing of the data, such as bandpass filtering, analog-to-digital conversion, and/or signal conditioning, prior to sending the data to the transceiver **120**. An alternative embodiment may include at least some front end processing embedded in any of the sensors described herein (such as sensors **102**, **104**, **204**, **202**, **208**, **412**, **804**, **840**, **808**) or cable hub **806** (see FIG. 8).

[**0066**] In certain embodiments, the cuff **112** is a reusable, disposable, or resposable device. Similarly, any of the sensors **102**, **104a** or cables **105**, **107** can be disposable or resposable. Resposable devices can include devices that are partially disposable and partially reusable. Thus, for example, the acoustic sensor **104a** can include reusable electronics but a disposable contact surface (such as an adhesive) where the sensor **104a** comes into contact with the patient’s skin. Generally, any of the sensors, cuffs, and cables described herein can be reusable, disposable, or resposable.

[**0067**] The cuff **112** can also can have its own power (e.g., via batteries) either as extra power or as a sole source of power for the transceiver **116**. The batteries can be disposable or reusable. In some embodiments, the cuff **112** can include one or more photovoltaic solar cells or other power sources. Likewise, batteries, solar sources, or other power sources can be provided for either of the sensors **102**, **104a**.

[0068] Referring to FIG. 1B, another embodiment of the system 100B is shown. In the system 100B, the blood pressure device 110b can communicate wirelessly with the acoustic sensor 104a and with the optical sensor 102. For instance, wireless transceivers (not shown) can be provided in one or both of the sensors 102, 104a, using any of the wireless technologies described above. The wireless transceivers can transmit data using any of a variety of wireless technologies, such as Wi-Fi (802.11x), Bluetooth (802.15.2), Zigbee (802.15.4), cellular telephony, infrared, RFID, satellite transmission, proprietary protocols, combinations of the same, and the like. The wireless transceivers can transmit data, raw signals, processed signals, conditioned signals, or the like to the blood pressure device 110b. The blood pressure device 110b can transmit these signals on to the wireless transceiver 120. In addition, in some embodiments, the blood pressure device 110b can also process the signals received from the sensors 102, 104a prior to transmitting the signals to the wireless transceiver 120. The sensors 102, 104a can also transmit data, raw signals, processed signals, conditioned signals, or the like directly to the wireless transceiver 120 or patient monitor. In one embodiment, the system 100B shown can be considered to be a body LAN, piconet, or other individual network.

[0069] FIGS. 1C and 1D illustrate another embodiment in which a wireless monitor 150 is secured to the arm of the patient. The wireless monitor 150 is a fully functional stand-alone monitor capable of various physiological measurements. The wireless monitor is small and light enough to comfortably be secured to and carried around on the arm of a patient. In the embodiment shown in FIG. 1C, the wireless monitor 150 connects to an acoustic respiration sensor 104A on a first side of patient monitor 150 and an oximeter sensor 102 on a second side of patient monitor 150. This configuration of connected sensors to opposite sides of the monitor prevents cable clutter and entanglements. The wireless monitor 150 includes a screen 154. The wireless monitor 150 couples to and is held to the arm of the patient by arm band 152. In FIG. 1C, the arm band is not an inflatable blood pressure cuff, however, as described with respect to the other figures, the arm band 152 can incorporate a blood pressure cuff for blood pressure readings.

[0070] The wireless monitor 150 can transmit data to a bedside monitor using any of a variety of wireless technologies, such as Wi-Fi (802.11x), Bluetooth (802.15.2), Zigbee (802.15.4), cellular telephony, infrared, RFID, satellite transmission, proprietary protocols, combinations of the same, and the like.

[0071] In an embodiment shown in FIG. 1D, the monitor 150 can be docked to a docking station 163. The docking station 163 includes a bedside monitor 164 and docking station adapter 160. Docking station adapter 160 adapts an otherwise incompatible docking port of bedside monitor 164 so that patient monitor 150 can dock. The docking station adapter 162 includes a port 162 for docking with the patient monitor 150. When the patient monitor 150 is physically docked in the docking station adapter 160, the patient monitor 150 can communicate with the bedside monitor 164 over a wired connection.

[0072] Also shown in FIG. 1D is handheld patient monitor 166. Handheld monitor 166 is configured to dock directly to bedside monitor 164 without the need for a docking station adapter 162. When the handheld monitor 166 is physically

docked in the bedside monitor 164, the handheld monitor 166 can communicate with the bedside monitor 164 over a wired connection.

[0073] FIG. 1E illustrates details of an embodiment of the wireless monitoring system 100A in a schematic form. Although other types of sensors can be used, the wireless monitoring system 100A is drawn in connection with the acoustic sensor 104a and the optical sensor 102. The system 100A sends signals from the acoustic sensor 104a and the optical sensor 102 to the sensor interface 170 and passes the signals to the DSP 172 for processing into representations of physiological parameters. In some embodiments, the DSP also communicates with a memory or information element, such as a resistor or capacitor, located on one of the sensors, such memory typically contains information related to the properties of the sensor that may be useful in processing the signals, such as, for example, emitter energy wavelengths.

[0074] In some embodiments, the physiological parameters are passed to an instrument manager 174, which may further process the parameters for display. The instrument manager 174 may include a memory buffer 176 to maintain this data for processing throughout a period of time. Memory buffer 176 may include RAM, Flash or other solid state memory, magnetic or optical disk-based memories, combinations of the same or the like.

[0075] The wireless transceiver 120 is capable of wirelessly receiving the physiological data and/or parameters from DSP 172 or instrument manager 174. The bedside monitor 916 can include one or more displays 178, control buttons, a speaker for audio messages, and/or a wireless signal broadcaster. The wireless transceiver 120 can also include a processor 180 to further process the data and/or parameters for display.

[0076] FIGS. 2A and 2B illustrate additional embodiments of patient monitoring systems 200A and 200B, respectively. In particular, FIG. 2A illustrates a wireless patient monitoring system 200A, while FIG. 2B illustrates a standalone patient monitoring system 200B.

[0077] Referring specifically to FIG. 2A, a blood pressure device 210a is connected to a patient 201. The blood pressure device 210a includes a wireless transceiver 216a, which can transmit sensor data obtained from the patient 201 to a wireless transceiver at 220 via antenna 218. The wireless transceiver 216a can transmit data using any of a variety of wireless technologies, such as Wi-Fi (802.11x), Bluetooth (802.15.2), Zigbee (802.15.4), cellular telephony, infrared, RFID, satellite transmission, proprietary protocols, combinations of the same, and the like.

[0078] In the depicted embodiment, the blood pressure device 210a includes an inflatable cuff 212a, which can include any of the features of the cuff 112 described above. Additionally, the cuff 212a includes a pocket 214, which holds the wireless transceiver 216a (shown by dashed lines). The wireless transceiver 216a can be electrically connected to the cuff 212a via a connector (see, e.g., FIG. 5) in some embodiments. As will be described elsewhere herein, the form of attachment of the wireless transceiver 216a to the cuff 212a is not restricted to a pocket connection mechanism and can vary in other implementations.

[0079] The wireless transceiver 216a is also coupled to various sensors in FIG. 2A, including an acoustic sensor 204a and/or an optical ear sensor 202a. The acoustic sensor 204a can have any of the features of the acoustic sensor 104 described above. The ear clip sensor 202a can be an optical

sensor that obtains physiological information regarding one or more blood parameters of the patient 201. These parameters can include any of the blood-related parameters described above with respect to the optical sensor 102. In one embodiment, the ear clip sensor 202a is an LNOP TC-I ear reusable sensor available from Masimo® Corporation of Irvine, Calif. In some embodiments, the ear clip sensor 202a is a concha ear sensor (see FIGS. 4A and 4B).

[0080] Advantageously, in the depicted embodiment, the sensors 202a, 204a are coupled to the wireless transceiver 216a via a single cable 205. The cable 205 is shown having two sections, a cable 205a and a cable 205b. For example, the wireless transceiver 216a is coupled to an acoustic sensor 204a via the cable 205b. In turn, the acoustic sensor 204a is coupled to the optical ear sensor 202a via the cable 205a. Advantageously, because the sensors 202a, 204a are attached to the wireless transceiver 216a in the cuff 212 in the depicted embodiment, the cable 205 is relatively short and can thereby increase the patient's 201 freedom of movement. Moreover, because a single cable 205 is used to connect two or more different types of sensors, such as sensors 202a, 204a, the patient's mobility and comfort can be further enhanced.

[0081] In some embodiments, the cable 205 is a shared cable 205 that is shared by the optical ear sensor 202a and the acoustic sensor 204a. The shared cable 205 can share power and ground lines for each of the sensors 202a, 204a. Signal lines in the cable 205 can convey signals from the sensors 202a, 204a to the wireless transceiver 216a and/or instructions from the wireless transceiver 216a to the sensors 202a, 204a. The signal lines can be separate within the cable 205 for the different sensors 202a, 204a. Alternatively, the signal lines can be shared as well, forming an electrical bus.

[0082] The two cables 205a, 205b can be part of a single cable or can be separate cables 205a, 205b. As a single cable 205, in one embodiment, the cable 205a, 205b can connect to the acoustic sensor 204a via a single connector. As separate cables, in one embodiment, the cable 205b can be connected to a first port on the acoustic sensor 204a and the cable 205a can be coupled to a second port on the acoustic sensor 204a.

[0083] FIG. 2B further illustrates an embodiment of the cable 205 in the context of a standalone patient monitoring system 200B. In the standalone patient monitoring system 200B, a blood pressure device 210b is provided that includes a patient monitor 216b disposed on a cuff 212b. The patient monitor 216b includes a display 219 for outputting physiological parameter measurements, trends, waveforms, patient data, and optionally other data for presentation to a clinician. The display 219 can be an LCD display, for example, with a touch screen or the like. The patient monitor 216b can act as a standalone device, not needing to communicate with other devices to process and measure physiological parameters. In some embodiments, the patient monitor 216b can also include any of the wireless functionality described above. For example, the patient monitor 216b can transmit data using any of a variety of wireless technologies, such as Wi-Fi (802.11x), Bluetooth (802.15.2), Zigbee (802.15.4), cellular telephony, infrared, RFID, satellite transmission, proprietary protocols, combinations of the same, and the like.

[0084] The patient monitor 216b can be integrated into the cuff 212b or can be detachable from the cuff 212b. In one

embodiment, the patient monitor 216b can be a readily available mobile computing device with a patient monitoring software application. For example, the patient monitor 216b can be a smart phone, personal digital assistant (PDA), or other wireless device. The patient monitoring software application on the device can perform any of a variety of functions, such as calculating physiological parameters, displaying physiological data, documenting physiological data, and/or wirelessly transmitting physiological data (including measurements or uncalculated raw sensor data) via email, text message (e.g., SMS or MMS), or some other communication medium. Moreover, any of the wireless transceivers or patient monitors described herein can be substituted with such a mobile computing device.

[0085] In the depicted embodiment, the patient monitor 216b is connected to three different types of sensors. An optical sensor 202b, coupled to a patient's 201 finger, is connected to the patient monitor 216b via a cable 207. In addition, an acoustic sensor 204b and an electrocardiograph (ECG) sensor 206 are attached to the patient monitor 206b via the cable 205. The optical sensor 202b can perform any of the optical sensor functions described above. Likewise, the acoustic sensor 204b can perform any of the acoustic sensor functions described above. The ECG sensor 206 can be used to monitor electrical activity of the patient's 201 heart.

[0086] Advantageously, in the depicted embodiment, the ECG sensor 206 is a bundle sensor that includes one or more ECG leads 208 in a single package. For example, the ECG sensor 206 can include one, two, or three or more leads. One or more of the leads 208 can be an active lead or leads, while another lead 208 can be a reference lead. Other configurations are possible with additional leads within the same package or at different points on the patient's body. Using a bundle ECG sensor 206 can advantageously enable a single cable connection via the cable 205 to the cuff 212b. Similarly, an acoustical sensor can be included in the ECG sensor 206 to advantageously reduce the overall complexity of the on-body assembly.

[0087] The cable 205a in FIG. 2B can connect two sensors to the cuff 212b, namely the ECG sensor 206 and the acoustic sensor 204b. Although not shown, the cable 205a can further connect an optical ear sensor to the acoustic sensor 204b in some embodiments, optionally replacing the finger optical sensor 202b. The cable 205a shown in FIG. 2B can have all the features described above with respect to cable 205a of FIG. 2A.

[0088] Although not shown, in some embodiments, any of the sensors, cuffs, wireless sensors, or patient monitors described herein can include one or more accelerometers or other motion measurement devices (such as gyroscopes). For example, in FIG. 2B, one or more of the acoustic sensor 204b, the ECG sensor 206, the cuff 212b, the patient monitor 216b, and/or the optical sensor 202b can include one or more motion measurement devices. A motion measurement device can be used by a processor (such as in the patient monitor 216b or other device) to determine motion and/or position of a patient. For example, a motion measurement device can be used to determine whether a patient is sitting up, lying down, walking, or the like.

[0089] Movement and/or position data obtained from a motion measurement device can be used to adjust a parameter calculation algorithm to compensate for the patient's motion. For example, a parameter measurement algorithm

that compensates for motion can more aggressively compensate for motion in response to high degree of measured movement. When less motion is detected, the algorithm can compensate less aggressively. Movement and/or position data can also be used as a contributing factor to adjusting parameter measurements. Blood pressure, for instance, can change during patient motion due to changes in blood flow. If the patient is detected to be moving, the patient's calculated blood pressure (or other parameter) can therefore be adjusted differently than when the patient is detected to be sitting.

[0090] A database can be assembled that includes movement and parameter data (raw or measured parameters) for one or more patients over time. The database can be analyzed by a processor to detect trends that can be used to perform parameter calculation adjustments based on motion or position. Many other variations and uses of the motion and/or position data are possible.

[0091] Although the patient monitoring systems described herein, including the systems 100A, 100B, 200A, and 200B have been described in the context of blood pressure cuffs, blood pressure need not be measured in some embodiments. For example, the cuff can be a holder for the patient monitoring devices and/or wireless transceivers and not include any blood pressure measuring functionality. Further, the patient monitoring devices and/or wireless transceivers shown need not be coupled to the patient via a cuff, but can be coupled to the patient at any other location, including not at all. For example, the devices can be coupled to the patient's belt (see FIGS. 3A and 3B), can be carried by the patient (e.g., via a shoulder strap or handle), or can be placed on the patient's bed next to the patient, among other possible locations.

[0092] Additionally, various features shown in FIGS. 2A and 2B can be changed or omitted. For instance, the wireless transceiver 216a can be attached to the cuff 212 without the use of the pocket 214. For example, the wireless transceiver can be sewn, glued, buttoned or otherwise attached to the cuff using any various known attachment mechanisms. Or, the wireless transceiver 216a can be directly coupled to the patient (e.g., via an armband) and the cuff 212 can be omitted entirely. Instead of a cuff, the wireless transceiver 216a can be coupled to a non-occlusive blood pressure device. Many other configurations are possible.

[0093] FIGS. 3A and 3B illustrate further embodiments of a patient monitoring system 300A, 300B having a single cable connecting multiple sensors. FIG. 3A depicts a tethered patient monitoring system 300A, while FIG. 3B depicts a wireless patient monitoring system 300B. The patient monitoring systems 300A, 300B illustrate example embodiments where a single cable 305 can be used to connect multiple sensors, without using a blood pressure cuff.

[0094] Referring to FIG. 3A, the acoustic and ECG sensors 204b, 206 of FIG. 2 are again shown coupled to the patient 201. As above, these sensors 204b, 206 are coupled together via a cable 205. However, the cable 250 is coupled to a junction device 230a instead of to a blood pressure cuff. In addition, the optical sensor 202b is coupled to the patient 201 and to the junction device 230a via a cable 207. The junction device 230a can anchor the cable 205b to the patient 201 (such as via the patient's belt) and pass through any signals received from the sensors 202b, 204b, 206 to a patient monitor 240 via a single cable 232.

[0095] In some embodiments, however, the junction device 230a can include at least some front-end signal processing circuitry. In some embodiments, the junction device 230a also includes a processor for processing physiological parameter measurements. Further, the junction device 230a can include all the features of the patient monitor 216b in some embodiments, such as providing a display that outputs parameters measured from data obtained by the sensors 202b, 204b, 206.

[0096] In the depicted embodiment, the patient monitor 240 is connected to a medical stand 250. The patient monitor 240 includes parameter measuring modules 242, one of which is connected to the junction device 230a via the cable 232. The patient monitor 240 further includes a display 246. The display 246 is a user-rotatable display in the depicted embodiment.

[0097] Referring to FIG. 3B, the patient monitoring system 300B includes nearly identical features to the patient monitoring system 300A. However, the junction device 230b includes wireless capability, enabling the junction device 230b to wirelessly communicate with the patient monitor 240 and/or other devices. The wireless patient monitoring system 300B can transmit data using any of a variety of wireless technologies, such as Wi-Fi (802.11x), Bluetooth (802.15.2), Zigbee (802.15.4), cellular telephony, infrared, RFID, satellite transmission, proprietary protocols, combinations of the same, and the like.

[0098] FIGS. 4A and 4B illustrate embodiments of patient monitoring systems 400A, 400B that depict alternative cable connection systems 410 for connecting sensors to a patient monitor 402. Like the cable 205 described above, these cable connection systems 410 can advantageously enhance patient mobility and comfort.

[0099] Referring to FIG. 4A, the patient monitoring system 400A includes a patient monitor 402a that measures physiological parameters based on signals obtained from sensors 412, 420 coupled to a patient. These sensors include an optical ear sensor 412 and an acoustic sensor 420 in the embodiment shown. The optical ear sensor 412 can include any of the features of the optical sensors described above. Likewise, the acoustic sensor 420 can include any of the features of the acoustic sensors described above.

[0100] The optical ear sensor 412 can be shaped to conform to the cartilaginous structures of the ear, such that the cartilaginous structures can provide additional support to the sensor 412, providing a more secure connection. This connection can be particularly beneficial for monitoring during pre-hospital and emergency use where the patient can move or be moved. In some embodiments, the optical ear sensor 412 can have any of the features described in U.S. application Ser. No. 12/658,872, filed Feb. 16, 2010, entitled "Ear Sensor," the disclosure of which is hereby incorporated by reference in its entirety.

[0101] An instrument cable 450 connects the patient monitor 402a to the cable connection system 410. The cable connection system 410 includes a sensor cable 440 connected to the instrument cable 250. The sensor cable 440 is bifurcated into two cable sections 416, 422, which connect to the individual sensors 412, 420 respectively. An anchor 430a connects the sensor cable 440 and cable sections 416, 422. The anchor 430a can include an adhesive for anchoring the cable connection system 410 to the patient, so as to reduce noise from cable movement or the like. Advantageously, the cable connection system 410 can reduce the

number and size of cables connecting the patient to a patient monitor **402a**. The cable connection system **410** can also be used to connect with any of the other sensors, patient-worn monitors, or wireless devices described above.

[0102] FIG. 4B illustrates the patient monitoring system **400B**, which includes many of the features of the monitoring system **400A**. For example, an optical ear sensor **412** and an acoustic sensor **420** are coupled to the patient. Likewise, the cable connection system **410** is shown, including the cable sections **416**, **422** coupled to an anchor **430b**. In the depicted embodiment, the cable connection system **410** communicates wirelessly with a patient monitor **402b**. For example, the anchor **430b** can include a wireless transceiver, or a separate wireless dongle or other device (not shown) can couple to the anchor **430b**. The anchor **430b** can be connected to a blood pressure cuff, wireless transceiver, junction device, or other device in some embodiments. The wireless transceiver, wireless dongle, or other device can transmit data using any of a variety of wireless technologies, such as Wi-Fi (802.11x), Bluetooth (802.15.2), Zigbee (802.15.4), cellular telephony, infrared, RFID, satellite transmission, proprietary protocols, combinations of the same, and the like.

[0103] FIG. 5 illustrates a more detailed embodiment of a wireless transceiver **516**. The wireless transceiver **516** can have all of the features of the wireless transceiver **516** described above. For example, the wireless transceiver **516** can connect to a blood pressure cuff and to one or more physiological sensors, and the transceiver **516** can transmit sensor data to a wireless receiver. The wireless transceiver **516** can transmit data using any of a variety of wireless technologies, such as Wi-Fi (802.11x), Bluetooth (802.15.2), Zigbee (802.15.4), cellular telephony, infrared, RFID, satellite transmission, proprietary protocols, combinations of the same, and the like.

[0104] The depicted embodiment of the transceiver **516** includes a housing **530**, which includes connectors **552** for sensor cables (e.g., for optical, acoustic, ECG, and/or other sensors) and a connector **560** for attachment to a blood pressure cuff or other patient-wearable device. The transceiver **516** further includes an antenna **518**, which although shown as an external antenna, can be internal in some implementations.

[0105] The transceiver **516** can include one or more connectors on one or more sides of the housing **530**. Providing connectors on different sides of the housing **530** allows for convenient sensor connection and prevents the sensor cables from tangling. For example, as shown in FIG. 5, the housing can include two connectors **552** on a first side of the housing **530** and an additional connector **560** on a second side of the housing **530**.

[0106] In addition, the transceiver **516** includes a display **554** that depicts values of various parameters, such as systolic and diastolic blood pressure, SpO₂, and respiratory rate (RR). The display **554** can also display trends, alarms, and the like. The transceiver **516** can be implemented with the display **554** in embodiments where the transceiver **516** also acts as a patient monitor. The transceiver **516** further includes controls **556**, which can be used to manipulate settings and functions of the transceiver **516**.

[0107] FIGS. 6A through 6C illustrate embodiments of wireless patient monitoring systems **600**. These wireless patient monitoring systems can transmit data using any of a variety of wireless technologies, such as Wi-Fi (802.11x),

Bluetooth (802.15.2), Zigbee (802.15.4), cellular telephony, infrared, RFID, satellite transmission, proprietary protocols, combinations of the same, and the like.

[0108] FIG. 6A illustrates a patient monitoring system **600A** that includes a wireless transceiver **616**, which can include the features of any of the transceivers **116**, **216a** described above. The transceiver **616** provides a wireless signal over a wireless link **612** to a patient monitor **620**. The wireless signal can include physiological information obtained from one or more sensors, physiological information that has been front-end processed by the transceiver **616**, or the like.

[0109] The patient monitor **620** can act as the wireless transceiver **220** of FIG. 2. The patient monitor **620** can process the wireless signal received from the transceiver **616** to obtain values, waveforms, and the like for one or more physiological parameters. The patient monitor **620** can perform any of the patient monitoring functions described above with respect to FIGS. 2 through 5.

[0110] In addition, the patient monitor **620** can provide at least some of the physiological information received from the transceiver **616** to a multi-patient monitoring system (MMS) **640** over a network **630**. The MMS **640** can include one or more physical computing devices, such as servers, having hardware and/or software for providing the physiological information to other devices in the network **630**. For example, the MMS **640** can use standardized protocols (such as TCP/IP) or proprietary protocols to communicate the physiological information to one or more nurses' station computers (not shown) and/or clinician devices (not shown) via the network **630**. In one embodiment, the MMS **640** can include some or all the features of the MMS described in U.S. Publication No. 2008/0188760, referred to above.

[0111] The network **630** can be a LAN or WAN, wireless LAN ("WLAN"), or other type of network used in any hospital, nursing home, patient care center, or other clinical location. In some implementations, the network **210** can interconnect devices from multiple hospitals or clinical locations, which can be remote from one another, through the Internet, one or more Intranets, a leased line, or the like. Thus, the MMS **640** can advantageously distribute the physiological information to a variety of devices that are geographically co-located or geographically separated.

[0112] FIG. 6B illustrates another embodiment of a patient monitoring system **600B**, where the transceiver **616** transmits physiological information to a base station **624** via the wireless link **612**. In this embodiment, the transceiver **616** can perform the functions of a patient monitor, such as any of the patient monitor functions described above. The transceiver **616** can provide processed sensor signals to the base station **624**, which forwards the information on to the MMS **640** over the network **630**.

[0113] FIG. 6C illustrates yet another embodiment of a patient monitoring system **600B**, where the transceiver **616** transmits physiological information directly to the MMS **640**. The MMS **640** can include wireless receiver functionality, for example. Thus, the embodiments shown in FIGS. 6A through 6C illustrate that the transceiver **616** can communicate with a variety of different types of devices.

[0114] FIG. 7 illustrates an embodiment of a physiological parameter display **700**. The physiological parameter display **700** can be output by any of the systems described above. For instance, the physiological parameter display **700** can be output by any of the wireless receivers, transceivers, or

patient monitors described above. The parameter display **700** can be output over a variety of wireless technologies, such as Wi-Fi (802.11x), Bluetooth (802.15.2), Zigbee (802.15.4), cellular telephony, infrared, RFID, satellite transmission, proprietary protocols, combinations of the same, and the like. Advantageously, in certain embodiments, the physiological parameter display **700** can display multiple parameters, including noninvasive blood pressure (NIBP) obtained using both oscillometric and non-oscillometric techniques.

[0115] The physiological parameter display **700** can display any of the physiological parameters described above, to name a few. In the depicted embodiment, the physiological parameter display **700** is shown displaying oxygen saturation **702**, heart rate **704**, and respiratory rate **706**. In addition, the physiological parameter display **700** displays blood pressure **708**, including systolic and diastolic blood pressure.

[0116] The display **700** further shows a plot **710** of continuous or substantially continuous blood pressure values measured over time. The plot **710** includes a trace **712a** for systolic pressure and a trace **712b** for diastolic pressure. The traces **712a**, **712b** can be generated using a variety of devices and techniques. For instance, the traces **712a**, **712b** can be generated using any of the velocity-based continuous blood pressure measurement techniques described above and described in further detail in U.S. Pat. Nos. 5,590,649 and 5,785,659, referred to above.

[0117] Periodically, oscillometric blood pressure measurements (sometimes referred to as Gold Standard NIBP) can be taken, using any of the cuffs described above. These measurements are shown by markers **714** on the plot **710**. By way of illustration, the markers **714** are “X’s” in the depicted embodiment, but the type of marker **714** used can be different in other implementations. In certain embodiments, oscillometric blood pressure measurements are taken at predefined intervals, resulting in the measurements shown by the markers **714**.

[0118] In addition to or instead of taking these measurements at intervals, oscillometric blood pressure measurements can be triggered using ICI techniques, e.g., based at least partly on an analysis of the noninvasive blood pressure measurements indicated by the traces **712a**, **712b**. Advantageously, by showing both types of noninvasive blood pressure measurements in the plot **710**, the display **700** can provide a clinician with continuous and oscillometric blood pressure information.

[0119] FIG. 8 illustrates another embodiment of a patient monitoring system **800**. The features of the patient monitoring system **800** can be combined with any of the features of the systems described above. Likewise, any of the features described above can be incorporated into the patient monitoring system **800**. Advantageously, in the depicted embodiment, the patient monitoring system **800** includes a cable hub **806** that enables one or many sensors to be selectively connected and disconnected to the cable hub **806**.

[0120] Like the patient monitoring systems described above, the monitoring system **800** includes a cuff **810** with a patient device **816** for providing physiological information to a monitor **820** or which can receive power from a power supply (**820**). The cuff **810** can be a blood pressure cuff or merely a holder for the patient device **816**. The patient device **816** can instead be a wireless transceiver having all the features of the wireless devices described above. The wireless transceiver can transmit data using any of a variety of wireless technologies, such as Wi-Fi (802.11x), Bluetooth

(802.15.2), Zigbee (802.15.4), cellular telephony, infrared, RFID, satellite transmission, proprietary protocols, combinations of the same, and the like.

[0121] The patient device **816** is in coupled with an optical finger sensor **802** via cable **807**. Further, the patient device **816** is coupled with the cable hub **806** via a cable **805a**. The cable hub **806** can be selectively connected to one or more sensors. In the depicted embodiment, example sensors shown coupled to the cable hub **806** include an ECG sensor **808a** and a brain sensor **840**. The ECG sensor **808a** can be single-lead or multi-lead sensor. The brain sensor **840** can be an electroencephalography (EEG) sensor and/or an optical sensor. An example of EEG sensor that can be used as the brain sensor **840** is the SEDLine™ sensor available from Masimo® Corporation of Irvine, Calif., which can be used for depth-of-anesthesia monitoring among other uses. Optical brain sensors can perform spectrophotometric measurements using, for example, reflectance pulse oximetry. The brain sensor **840** can incorporate both an EEG/depth-of-anesthesia sensor and an optical sensor for cerebral oximetry.

[0122] The ECG sensor **808a** is coupled to an acoustic sensor **804** and one or more additional ECG leads **808b**. For illustrative purposes, four additional leads **808b** are shown, for a 5-lead ECG configuration. In some embodiments, one or two additional leads **808b** are used instead of four additional leads. In some embodiments, up to at least 12 leads **808b** can be included. Acoustic sensors can also be disposed in the ECG sensor **808a** and/or lead(s) **808b** or on other locations of the body, such as over a patient’s stomach (e.g., to detect bowel sounds, thereby verifying patient’s digestive health, for example, in preparation for discharge from a hospital). Further, in some embodiments, the acoustic sensor **804** can connect directly to the cable hub **806** instead of to the ECG sensor **808a**.

[0123] As mentioned above, the cable hub **806** can enable one or many sensors to be selectively connected and disconnected to the cable hub **806**. This configurability aspect of the cable hub **806** can allow different sensors to be attached or removed from a patient based on the patient’s monitoring needs, without coupling new cables to the monitor **820**. Instead, a single, light-weight cable **832** couples to the monitor **820** in certain embodiments, or wireless technology can be used to communicate with the monitor **820** (see, e.g., FIG. 1). A patient’s monitoring needs can change as the patient is moved from one area of a care facility to another, such as from an operating room or intensive care unit to a general floor. The cable configuration shown, including the cable hub **806**, can allow the patient to be disconnected from a single cable to the monitor **820** and easily moved to another room, where a new monitor can be coupled to the patient. Of course, the monitor **820** may move with the patient from room to room, but the single cable connection **832** rather than several can facilitate easier patient transport.

[0124] Further, in some embodiments, the cuff **810** and/or patient device **816** need not be included, but the cable hub **806** can instead connect directly to the monitor wirelessly or via a cable. Additionally, the cable hub **806** or the patient device **816** may include electronics for front-end processing, digitizing, or signal processing for one or more sensors. Placing front-end signal conditioning and/or analog-to-digital conversion circuitry in one or more of these devices can make it possible to send continuous waveforms wirelessly

and/or allow for a small, more user-friendly wire (and hence cable **832**) routing to the monitor **820**.

[**0125**] The cable hub **806** can also be attached to the patient via an adhesive, allowing the cable hub **806** to become a wearable component. Together, the various sensors, cables, and cable hub **806** shown can be a complete body-worn patient monitoring system. The body-worn patient monitoring system can communicate with a patient monitor **820** as shown, which can be a tablet, handheld device, a hardware module, or a traditional monitor with a large display, to name a few possible devices.

[**0126**] FIGS. 9A-9D illustrate another embodiment of a wireless monitoring system **900** including a wireless monitor **902** coupled to a sensor **930**. The wireless monitoring system **900** is configured to connect to one or more sensors and/or a bedside monitor. The features of the wireless monitoring system **900** can be combined with any of the features of the systems described above. Likewise, any of the features described above can be incorporated into the patient monitoring system **900**. The wireless monitor **902** includes a removable battery **904** having a data storage component. The removable battery **904** can be used to pair the wireless monitor **902** with the correct bedside monitor as described below. The battery **904** is positioned on the front side of the wireless monitor **902**, so the battery **904** can be replaced without disconnecting a wireless monitor housing from the patient. Further details of these drawings are described below.

[**0127**] FIG. 10 illustrates details of an embodiment of the wireless monitoring system **900** in a schematic form. Typically, the sensor **930** includes energy emitters **1016** located on one side of a patient monitoring site **1018** and one or more detectors **1020** located generally opposite. The patient monitoring site **1018** is usually a patient's finger (as pictured), toe, ear lobe, or the like. Energy emitters **1016**, such as LEDs, emit particular wavelengths of energy through the flesh of a patient at the monitoring site **1018**, which attenuates the energy. The detector(s) **1020** then detect the attenuated energy and send representative signals to the wireless monitor **902**.

[**0128**] The wireless monitor **902** can include a sensor interface **1024** and a digital signal processor (DSP) **1026**. The sensor interface **1024** receives the signals from the sensor **930** detector(s) **1020** and passes the signals to the DSP **1026** for processing into representations of physiological parameters. In some embodiments, the DSP **1026** also communicates with a memory or information element, such as a resistor or capacitor, **1030** located on the sensor **930**, such memory typically contains information related to the properties of the sensor that may be useful in processing the signals, such as, for example, emitter **1016** energy wavelengths.

[**0129**] In some embodiments, the physiological parameters are passed to an instrument manager **1028**, which may further process the parameters for display by a bedside monitor **916**. The instrument manager **1028** may include a memory buffer **1034** to maintain this data for processing throughout a period of time. Memory buffer **1034** may include RAM, Flash or other solid state memory, magnetic or optical disk-based memories, combinations of the same or the like.

[**0130**] In some embodiments, the wireless monitor is able to display one or more physiological parameters. The wireless monitor **902** can include one or more displays **1036**,

control buttons **1040**, one or more speakers **1038** for audio messages. Control buttons **1040** may comprise a keypad, a full keyboard, a touch screen, a track wheel, and the like.

[**0131**] The wireless monitor **902** is powered by a battery **904**. In some embodiments, the battery **904** directly or indirectly powers the sensor interface **1024**, DSP **1026**, and the instrument manager **1028**.

[**0132**] The battery **904** includes memory **932**, such memory stores wireless communication information needed for the wireless monitor **902** to wirelessly communicate with bedside monitor **916**. The battery **904** can communicate the information stored on the memory **932** to the wireless monitor **902** or bedside monitor **916**, and the memory **932** can store information received from the wireless monitor **902** or bedside monitor **916**.

[**0133**] The bedside monitor **916** wirelessly receives the physiological data and/or parameters from the wireless monitor **902** and is able to display one or more physiological parameters. The bedside monitor **916** can include one or more displays **1008**, control buttons **1010**, a speaker **1012** for audio messages, and/or a wireless signal broadcaster. Control buttons **1010** may comprise a keypad, a full keyboard, a track wheel, and the like.

[**0134**] As shown in FIG. 10, the wireless monitor **902** can include an optional internal battery **905** capable of powering the wireless monitor **902** when the battery **904** is disconnected from the wireless monitor **902**. The internal battery **905** can include additional backup memory **933** to store information when the battery **904** is disconnected from the wireless monitor **902**. The internal battery **905** can be useful when a caregiver replaces the battery **904** with a different, fully-charged battery. While the battery **904** is disconnected from the wireless monitor **902**, the wireless monitor **902** can continue to display and communicate information.

[**0135**] In several embodiments, the wireless patient monitoring system includes one or more sensors, including, but not limited to, a sensor **930** to monitor oxygen saturation and pulse rate. These physiological parameters can be measured using a pulse oximeter. In general, the sensor **930** has light emitting diodes that transmit optical radiation of red and infrared wavelengths into a tissue site and a detector that responds to the intensity of the optical radiation after absorption (e.g. by transmission or transreflectance) by pulsatile arterial blood flowing within the tissue site. Based on this response, a processor determines measurements for SpO₂, pulse rate, and can output representative plethysmographic waveforms. Thus, "pulse oximetry" as used herein encompasses its broad ordinary meaning known to one of skill in the art, which includes at least those noninvasive procedures for measuring parameters of circulating blood through spectroscopy.

[**0136**] The wireless monitoring system **900** can include any of the sensors described herein in addition to or in alternative to the pulse oximeter. For example, the wireless monitoring system **900** can also include sensors for monitoring acoustics, sedation state, blood pressure, ECG, body temperature, and/or cardiac output. The wireless monitor may also include an accelerometer or gyroscope. The wireless patient monitoring system may include any of the above-mentioned sensors alone or in combination with each other.

[**0137**] In several embodiments, the wireless monitor **902** includes a wireless transmitter to transmit sensor data and/or a wireless receiver to receive data from another wireless

transmitter or transceiver. By transmitting the sensor data wirelessly, the wireless monitor 902 can advantageously replace some or all cables that connect patients to bedside monitoring devices. Alternatively, the wireless monitor 902 calculates physiological parameters based on the sensor data and wirelessly transmits the physiological parameters and/or the sensor data itself to the bedside monitor. The physiological parameter can be numerical information, such as oxygen saturation (SpO₂) or pulse rate, or a graphical depiction of the sensor data. The data processors can be positioned in the wireless monitor housing or the battery. By configuring the wireless monitor 902 to calculate the physiological parameter, less data transfer is required to transmit information from the wireless monitor to the bedside monitor. Processing the sensor data in the wireless monitor 902 also improves the quality of the signal transferred to the bedside monitor.

[0138] As shown in FIGS. 9B-9C, the wireless monitor 902 includes a removable battery 904 and a base 906. The base 906 can include processing and wireless transmission capabilities and/or share processing function with the battery 904. Removable battery 904 includes a release mechanism 912 to release the battery 904 from the base 906. As depicted in FIG. 9B, the base 906 can include a battery receiving portion 914 and a notch 917 to lock the removable battery 904 in place. Wireless monitor 902 can have one or more outlets 910 to plug in the sensor 930, such as the pulse oximeter, acoustic respiratory sensor, ECG, sedation sensor, blood pressure cuff, or any other sensor. In some embodiments, one or more outlets 910 can be positioned on one or more sides of the wireless monitor 902. For example, the wireless monitor can include an outlet on one side for an acoustic respiratory sensor and an outlet on an opposite side for a pulse oximeter.

[0139] Wireless monitor 902 can include an opening 908 through which an arm band 934 can be passed to secure the wireless monitor 902 to the arm of the patient, as shown in FIG. 9A. The arm band 934 can be reusable, disposable or resposable. Similarly, any of the sensors 930 can be disposable or resposable. Resposable devices can include devices that are partially disposable and partially reusable. Thus, for example, the acoustic sensor can include reusable electronics, but a disposable contact surface (such as an adhesive) where the sensor comes into contact with the patient's skin.

[0140] The sensors 930 and/or wireless monitor 902 need not be worn around the patient's arm, but can be worn at any other location, including not at all. The sensors 930 and/or wireless monitor 902 need not be coupled to an arm band, but can be coupled to a patient's belt or a chest strap, can be carried by the patient (e.g., via a shoulder strap or handle), or can be placed on the patient's bed next to the patient, among other locations.

[0141] FIG. 9D illustrates the battery 904 docked with a bedside monitor 916. Bedside monitor 916 has a battery charging station 922 for receiving and charging removable battery 904. When the wireless monitor 902 is using a first battery, the battery charging station 922 can charge a second battery, so when the battery levels of the first battery are low, a second battery is readily available. Each battery is capable of powering the wireless monitor 902 for at least one nursing shift, so each nurse only has to replace the battery once either at the beginning or end of each shift.

[0142] An adapter 918 can be integrated with the bedside monitor or separately connected to bedside monitor 916. The bedside monitor 916 includes a release mechanism 926 to

release the adaptor 918 from the bedside monitor 916. Adaptor 918 includes docking station 920 to receive the entire wireless monitor (not shown). Locking mechanism 924 holds the wireless monitor 902 in place. Other components may be connected to the bedside monitor 916 instead of the adaptor 918, such as a handheld patient monitor device.

[0143] In some embodiments, the adaptor 918 includes a docking station 920 to receive the entire wireless monitor 902. The wireless monitor 902 can be placed in the docking station 920 when it is not in use to prevent the wireless monitor 902 from being lost. The bedside monitor 916 can charge the battery 904 when the wireless monitor 902 is connected to the bedside monitor 916. In certain aspects, the bedside monitor 916 can communicate a password, unique identifier, appropriate channel information, or other wireless communication information to the wireless monitor 902, and vice versa, when the wireless monitor 902 is connected to the bedside monitor 916.

[0144] As shown in FIG. 9D, the bedside monitor 916 is capable of simultaneously receiving a first battery and a wireless monitor 902 having a second battery. The bedside monitor 916 is configured to charge and sync both the first and second batteries. When the first battery and/or the wireless monitor 902 and second battery are physically docked in the bedside monitor 916, the first and/or second battery can communication with the bedside monitor 916 over a wired connection.

[0145] The bedside monitor 916 can include a display screen 928 for displaying the physiological parameters, including trends, waveforms, related alarms, and the like. In certain aspects, the bedside monitor 916 can display the appropriate channel for communication and/or whether the wireless monitor 902 is properly communicating with the bedside monitor 916.

[0146] The bedside monitor 916 can include a computer-readable storage medium, such as a physical storage device, for storing the physiological data. In certain aspects, the bedside monitor can include a network interface for communicating the physiological data to one or more hosts over a network, such as to a nurse's station computer in a hospital network.

[0147] The wireless monitor 902 can transmit data to the bedside monitor 916 using any of a variety of wireless technologies, such as Wi-Fi (802.11x), Bluetooth, ZigBee, cellular telephony, infrared, RFID, satellite transmission, proprietary protocols, combinations of the same, and the like. The wireless monitor 902 can perform solely telemetry functions, such as measuring and reporting information about the patient.

[0148] The wireless monitor 902, or any of the wireless monitor embodiments discussed herein, can be configured to utilize different wireless technologies. In certain scenarios, it may be desirable to transmit data over Bluetooth or ZigBee, for example, when the distance between the wireless monitor 902 and the bedside monitor 916 is within range of Bluetooth or ZigBee communication. Transmitting data using Bluetooth or ZigBee is advantageous because these technologies require less power than other wireless technologies. In other scenarios, it may be desirable to transmit data using Wi-Fi or cellular telephony, for example, when the wireless monitor is out of range of communication for Bluetooth or ZigBee. A wireless monitor 902 may be able to transmit data over a greater distance using Wi-Fi or cellular

telephony than other wireless technologies. In still other scenarios, it may be desirable to transmit data using a first wireless technology and automatically switch to a second wireless technology in order to maximize data transfer and energy efficiency.

[0149] In some embodiments, the wireless monitor 902 automatically transmits data over Bluetooth or ZigBee when the wireless monitor 902 is within a pre-determined distance from bedside monitor 916. The wireless monitor 902 automatically transmits data over Wi-Fi or cellular telephony when the wireless monitor 902 is beyond a pre-determined distance away from the bedside monitor 916. In certain embodiments, the wireless monitor 902 can automatically convert from Bluetooth or ZigBee to Wi-Fi or cellular telephony, and vice versa, depending on the distance between the wireless monitor 902 and bedside monitor 916.

[0150] In some embodiments, the wireless monitor 902 automatically transmits data over Bluetooth or ZigBee when the Bluetooth or ZigBee signal strength is sufficiently strong or when there is interference with Wi-Fi or cellular telephony. The wireless monitor 902 automatically transmits data over Wi-Fi or cellular telephony when the Bluetooth or ZigBee signal strength is not sufficiently strong. In certain embodiments, the wireless monitor 902 can automatically convert from Bluetooth or ZigBee to Wi-Fi or cellular telephony, and vice versa, depending on signal strength.

[0151] Existing wireless bedside monitoring devices can be difficult to use because it can be difficult to pair the wireless device with the correct bedside monitor, making it difficult to switch wireless devices or switch bedside monitors. Some wireless systems require the care provider to program the wireless device to communicate with the correct patient monitor. Other wireless systems require a separate token or encryption key and several steps to pair the wireless device with the correct bedside monitors. Some systems require the token to be connected to the bedside monitor, then connected to the wireless device, and then reconnected to the bedside monitor.

[0152] In certain scenarios, it may be desirable to share wireless communication information between a wireless monitor 902 and a bedside monitor 916 without a separate token or encryption key. In some embodiments, the removable battery 904 includes a data storage component, such as memory 932, capable of storing wireless communication information. The battery 904 is configured to connect to both the wireless monitor 902 and the bedside monitor 916. Combining the battery 904 with a data storage component can decrease the total number of components and decrease the number of steps it takes to transfer wireless communication information between the wireless monitor 902 and bedside monitor 916 because a separate token or encryption key is not needed. This method of data transfer also eliminates user input errors arising from users having to program the wireless monitor 902 and/or bedside monitor 916 and allows for easy transfer of wireless communication information between the wireless monitor 902 and bedside monitor 916.

[0153] For security purposes, it may be desirable to use security tokens to ensure that the correct bedside monitor 916 receives the correct wirelessly transmitted data. Security tokens prevent the bedside monitor 916 from accessing the transmitted data unless wireless monitor 902 and bedside monitor 916 share the same password. The password may be a word, passphrase, or an array of randomly chosen bytes.

[0154] When the battery 904 is connected to the bedside monitor 916, the bedside monitor 916 can communicate a password to the battery 904, and the battery 904 stores the password on its data storage component. The battery 904 can communicate a password for the wireless monitor 902 to the bedside monitor 916. The battery 904 can then be disconnected from the bedside monitor 916 and connected to the wireless monitor 902. When the battery 904 is connected to the wireless monitor 902, the battery 904 can communicate the password to the wireless monitor 902. The wireless monitor 902 can then communicate wirelessly with the correct bedside monitor 916.

[0155] In some scenarios, it may be desirable to pair the wireless monitor 902 with the bedside monitor 916 to avoid interference from other wireless devices. When the removable battery 904 is connected to the bedside monitor 916, the bedside monitor 916 communicates a unique identifier to the battery 904, and the battery 904 stores the unique identifier on its data storage component. The battery 904 can communicate a unique identifier for the wireless monitor 902 to the bedside monitor 916. The battery 904 can then be disconnected from the bedside monitor 916 and connected to the wireless monitor 902. When the battery 904 is connected to the wireless monitor 902, the battery 904 can communicate the unique identifier to the wireless monitor 902, so that the wireless monitor 902 can transmit data to the correct bedside monitor 916.

[0156] In some scenarios, it is desirable for the wireless monitor 902 to be configured to transmit data over the correct channel. Channels provide a mechanism to avoid sources of wireless interference. When the removable battery 904 is connected to the bedside monitor 916, the bedside monitor 916 communicates the appropriate channel to the battery 904, and the battery 904 stores the channel information on its data storage component. If necessary, the battery 904 can communicate a wireless monitor channel to the bedside monitor 916. The battery 904 is then disconnected from the bedside monitor 916 and connected to the wireless monitor 902. When the battery 904 is connected to the wireless monitor 902, the battery 904 can communicate the appropriate channel information to the wireless monitor 902, thereby ensuring the wireless monitor 902 transmits data over the correct channel.

[0157] The battery 904, or any battery embodiment described herein, can receive or communicate any one or combination of passwords, tokens, or channels as described above. The wireless communication information can include information to communicate over each protocol the wireless monitor 902 is configured to communicate over. For example, if the wireless monitor 902 is capable of communicating over Wi-Fi and Bluetooth, then the battery 904 is capable of receiving wireless communication information to communicate over both Wi-Fi and Bluetooth.

[0158] In some scenarios, the method in any of the above mentioned methodologies may be reversed. For example, in some embodiments, the battery 904 is initially connected to the wireless monitor 902. When the battery 904 is connected to the wireless monitor 902, the wireless monitor 902 can communicate wireless communication information identifying the wireless monitor 902 to the battery 904, and the battery 904 can store the information on its data storage component. The battery can communicate wireless communication information identifying the bedside monitor 916 to the wireless monitor 902. After the battery 904 is discon-

nected from the wireless monitor 902, the battery 904 is connected to the bedside monitor 916. The battery 904 can then communicate wireless communication information stored on the data storage component to the bedside monitor 916, such as a password, unique identifier, channel, or other data information.

[0159] FIG. 11 illustrates an embodiment for using the wireless patient monitoring system that can be used in connection with any wireless patient monitoring system described herein. The operator connects the removable battery to the bedside monitor (block 1102) and the bedside monitor and the battery communicate wireless communication information with each other (block 1104). The operator then disconnects the battery from the bedside monitor (block 1106) and connects the battery to the wireless monitor (block 1108). The battery and the wireless monitor communicate wireless communication information with each other (block 1110). After the wireless monitor receives data from the one or more sensors (block 1112), the wireless monitor processes the sensor data into representations of physiological parameters (block 1114). The wireless monitor then wirelessly communicates the physiological parameters and/or the sensor data to the bedside monitor (block 1116).

[0160] In some embodiments, the data storage component of the battery 904 stores wireless communication information related to the wireless monitor 902. The wireless communication information can be a password, unique identifier, channel, etc. When the battery 904 is engaged with the bedside monitor 916, the bedside monitor 916 can communicate wireless communication information to the battery 904, and the battery 904 can communicate wireless communication information to the bedside monitor 916. The battery 904 is then disconnected from the bedside monitor 916 and connected to the wireless monitor 902. Since the battery 904 already communicated the wireless communication information to the bedside monitor 916, the battery 904 provides all remaining wireless communication information to the wireless monitor. The wireless monitor reconfigures itself according to the information on the battery and no further information is required to be communicated with the bedside monitor 916. This reduces the total number of steps necessary to pair the wireless monitor 902 with the correct bedside monitor 916.

[0161] FIG. 12 illustrates another embodiment of the wireless patient monitor 1202. The features of the wireless patient monitor 1202 can be combined with any of the features of the systems described above. Likewise, any of the features described above can be incorporated into the patient monitor 1202.

[0162] As shown in FIG. 12, the wireless patient monitor 1202 can include a housing 1205 that removably engages a battery 1204. The monitor 1202 can include a release mechanism 1212 for releasing the battery 1204 from the housing 1206 and/or one or more outlets 1210 for engaging one or more sensors.

[0163] The wireless patient monitor 1202 can include a wireless transceiver capable of transmitting data using any of a variety of wireless technologies, such as Wi-Fi (802.11x), Bluetooth (802.15.2), Zigbee (802.15.4), cellular telephony, infrared, RFID, satellite transmission, proprietary protocols, combinations of the same, and the like.

[0164] As shown in FIG. 12, the battery 1204 can include a display screen 1240. The display screen 1240 can indicate any number of parameters, including, but not limited to,

physiological parameters, battery levels, and wireless signal strength. Positioning the display screen 1240 on the battery 1204 helps reduce the size of the housing.

[0165] The display screen 1240 can include a touch interface to permit a user to access different parameters or settings (e.g., display settings, connectivity settings, etc.). In certain aspects, the display screen 1240 can rotate depending on the orientation of the battery 1204.

[0166] To save energy, the display screen 1240 can selectively display certain parameters depending on the location of the battery 1204. For example, if the battery is connected to the bedside monitor or disconnected from the wireless monitor, the battery may only display battery levels. If the battery is connected to the wireless monitor, then the battery may display additional parameters other than battery levels.

[0167] The display screen 1240 can selectively display certain parameters depending on the distance between the wireless monitor 1202 and the bedside monitor 1216. Referring to FIG. 13, if the wireless monitor 1202 is within a predetermined distance from the bedside monitor—(block 1300), then the display screen 1240 deactivates (block 1302). If the wireless monitor 1202 is not within a predetermined distance from the bedside monitor (block 1300), then the display screen 1240 initializes (block 1304). The display screen 1240 only needs to be active when the patient is not close to the bedside monitor.

[0168] The display screen 1240 can selectively display certain parameters depending on the type of wireless connection between the wireless monitor 1202 and the bedside monitor and/or hospital IT infrastructure. Referring to FIG. 14, if the wireless monitor 1202 wirelessly communicates physiological parameters and/or sensor data over Bluetooth (block 1410), then the display screen deactivates (block 1412). If the wireless monitor 1202 wirelessly communicates physiological parameters and/or sensor data over Wi-Fi (block 1414), then the display screen 1240 initializes (block 1416).

[0169] The wireless monitor 1202 can selectively transmit information over different wireless connections and display certain parameters depending on the distance between the wireless monitor 1202 and the bedside monitor. Referring to FIG. 15, if the wireless monitor 1202 is within a predetermined distance from the bedside monitor (block 1520), then the wireless monitor 1202 wirelessly communicates physiological parameters and/or sensor data to the bedside monitor over Bluetooth (block 1522). If the wireless monitor 1202 wirelessly communicates to the bedside monitor over Bluetooth (block 1522), then the display screen 1240 deactivates (block 1524). The display screen 1240 does not need to be active since the bedside monitor is nearby.

[0170] If the wireless monitor 1202 is not within a predetermined distance from the bedside monitor (block 1520), then the wireless monitor 1202 wirelessly communicates physiological parameters and/or sensor data to the bedside monitor over Wi-Fi (block 1526). If the wireless monitor 1202 wirelessly communicates to the bedside monitor over Wi-Fi (block 1526), then the display screen 1240 initializes (block 1528). If the wireless monitor 1202 is communicating over Wi-Fi, then it is more likely that the patient is not in the patient room. In that case, it is necessary to have a secondary display screen available to monitor the patient's physiological parameters.

[0171] Although FIGS. 14 and 15 were discussed in reference to Bluetooth and Wi-Fi, the system can wirelessly

communication information over ZigBee or cellular telephony. Also, the system may convert from a first wireless technology (e.g., Bluetooth) to a second wireless technology (Wi-Fi) based on signal strength rather than distance.

[0172] The wireless monitor 1202 can help the hospital staff monitor the patient when the patient is not close to the bedside monitor. When the patient is close to the bedside monitor, the bedside monitor will notify the staff if any of the patient's physiological parameters are irregular by activating an audible alarm and/or by alerting a staff member using the hospital IT infrastructure. When the patient is more than a pre-determined distance from the bedside monitor, the wireless monitor 1202 can send the physiological parameters and/or sensor data directly over the hospital IT infrastructure, so the hospital staff can continuously monitor the patient at the nurse's station or any other location. If the patient exhibits any irregular physiological parameters, the wireless monitor 1202 can activate an audible alarm and/or alert a staff member using the hospital IT infrastructure. The wireless monitor 1202 can use triangulation to provide the location of the patient, so the staff member can quickly find the patient. By configuring the wireless monitor 1202 to process the sensor data, the wireless monitor 1202 is capable of communicating physiological parameters over the hospital IT infrastructure without the bedside monitor.

[0173] Any of the systems described herein can include a display screen and can be configured to carry out any of the methods described in FIGS. 13-15.

[0174] FIGS. 16A-F illustrate another embodiment of a wireless patient monitoring system. The features of the wireless patient monitoring system can be combined with any of the features of the systems described above. Likewise, any of the features described above can be incorporated into the wireless patient monitoring system.

[0175] FIG. 16A illustrates the wireless monitor 1602 with the battery 1604 detached from the base 1606. The base 1606 can include processing and wireless transmission capabilities and/or share processing function with the battery 1604. The battery 1602 removably engages an anterior surface of the base 1606. The battery 1602 can engage the housing 1602 via a magnet, a clip, a band, a snap fit, a friction fit, or otherwise. The housing 1602 can include one or more outlets 1610 for engaging one or more sensors 1630. As shown in FIG. 16A, the housing 1206 can include an outlet on one end of the housing and another outlet on the opposite end of the housing. Disposing outlets on opposite ends of the housing can be useful to prevent sensor cables from tangling.

[0176] The battery 1604 can include a display screen 1640 and a user input device 1644. The user input device can activate the screen, adjust display settings, select physiological parameters to display, and/or otherwise control the display screen 1640. As shown in FIG. 16A, the user input device 1644 can be a touch pad. A user can tap the touch pad to select a feature and/or swipe in different directions to change selections. For example, the user can swipe right or left to change the parameters displayed on the display screen. Other functions can also be performed using the three inputs of the touch pad—left swipe, right swipe, and tap. Other user input devices 1644 can include one or more buttons, switches, or other control. In certain aspects, the display screen can be the user input device.

[0177] FIG. 16B illustrates a strap 1646 for securing the wireless monitor 1602 to the patient. The strap 1646 can

include any fabric, elastic, or otherwise flexible material. In certain aspects, the strap 1646 can be waterproof. One or both ends of the strap 1646 can be tapered. One or both ends of the strap 1646 can include a covering to protect the strap ends.

[0178] The strap 1646 can be secured to the patient as an arm band, a shoulder strap, a belt, or in any other configuration. A portion of the strap 1646 can be secured to another portion of the strap 1646 using Velcro 1660, clasps, adhesive, snap-fits, or any other connector. The strap 1646 can include a band (not shown) for securing an excess portion of the strap 1646.

[0179] As shown in FIG. 16B, the strap 1646 can include a connector 1650 for engaging the wireless monitor 1602 and an adjustment mechanism 1648 to adjust the length of the strap 1646 and/or secure any excess strap 1646. The connector 1650 can be an integral portion of the strap 1646 or a separately formed component secured to the strap 1646. As shown in FIG. 16B, the connector 1650 can include an opening 1656 on opposite sides of the connector 1650 for securing either end of the strap 1646. One or both ends of the strap 1646 can be removably secured to the connector 1650.

[0180] In certain aspects, the connector 1650 engages the housing by being disposed between the base 1606 and the battery 1604. At least a portion of the connector 1650 can overlay a portion of the housing. The connector 1650 can include certain features to mate with a corresponding feature of the base 1606 and/or battery 1604. For example, the connector 1650 can include one or more recesses 1652 configured to mate with one or more protrusions 1658 on the base 1606. As shown in FIG. 16C, the connector 1650 can include a recess 1652 on opposite ends of the connector 1650 that mate with protrusions 1658 on opposite ends of the base 1606. The connector 1650 can be flush with the protrusions 1658 to provide a flat surface for the battery 1604.

[0181] In other aspects, the connector 1650 can pass through an opening of the wireless monitor. For example, as shown in FIG. 12, the wireless monitor can include an opening 1208 for engaging the strap 1646. In still other aspects, the connector 1650 can engage the wireless monitor 1602 using clips, ties, buckles, buttons, or any other connector.

[0182] The wireless monitor 1602 can include a wireless transceiver capable of transmitting data using any of a variety of wireless technologies, such as Wi-Fi (802.11x), Bluetooth (802.15.2), Zigbee (802.15.4), cellular telephony, infrared, RFID, satellite transmission, proprietary protocols, combinations of the same, and the like.

[0183] FIGS. 16D-16F illustrate a bedside monitor 1616 configured to receive the wireless monitor 1602. The bedside monitor can include one or more input ports 1627 configured to receive cables. In certain aspects, the bedside monitor 1616 can include a port 1617 configured to receive a handheld device, such as the handheld monitor 166 shown in FIG. 1D. Further details about the handheld device can be found in U.S. application Ser. No. 13/651,167, filed Oct. 12, 2012, entitled "Medical Monitoring Hub," which is hereby incorporated by reference in its entirety.

[0184] The port 1617 can removably engage an adapter 1618. For example, the adapter 1618 can include a release mechanism 1626 to release the adapter 1618 from the port

1617. In certain aspects, the release mechanism **1626** is studded, so a user must use one or more tools to release the release mechanism **1626**.

[0185] The adapter **1618** can be configured to receive a battery **1604** and/or a wireless monitor **1602**. The adapter **1618** can include a docking adaptor door **1620** configured to receive the stand alone battery **1604** and/or and a port for receiving a the wireless monitor **1602** including a battery **1604**. In certain aspects, as shown in FIG. **16F**, the docking adaptor door **1620** can pivot to facilitate insertion and removal of the wireless monitor **1602**. When the battery **1604** and/or wireless monitor **1602** having a battery **1604** is physically connected to the adapter **1618**, the batteries **1606** can charge and can communicate and/or receive information from the bedside monitor **1616** over a wired connection.

[0186] FIGS. **17A-17C** illustrate another embodiment of a wireless monitor **1702**. The wireless monitor **1702** can include any of the other wireless monitor features described herein. Likewise, any of the other wireless monitor embodiments discussed herein can include any of the features of the wireless monitor **1702**.

[0187] The wireless monitor **1702** can include a battery **1704** removably engaged with a base **1706**. The base **1706** can include processing and wireless transmission capabilities and/or share processing function with the battery **1704**. FIG. **17A** illustrates an exploded view of the wireless monitor **1702**. The housing can include one or more outlets **1710** configured to connect to one or more sensors (not shown). The battery can include a display **1740** capable of displaying physiological parameters, connectivity information, and/or other content. The battery **1704** can include a touch pad **1744** or other user input device. The touch pad **1744** can permit the user to swipe right, swipe left, or tap to control the wireless monitor **1702**. The battery **1704** can include an additional user input device (e.g., button **1745**) that can activate/deactivate the wireless monitor or provide other functionality.

[0188] The battery can include one or more protrusions, ribs, struts, detents, or the like configured to be received in corresponding grooves, notches, recesses, openings, or the like in the base **1706**. FIG. **17B** illustrates views of an inner portion of the battery **1704** and an inner portion of the housing. The battery **1704** can include two protrusions **1741** on each end of the battery **1704** and along an inner portion of the battery **1704**. One or more of the protrusions **1741** can be a different size or shape from the other protrusions **1741**. The base **1706** can include two grooves **1743** on each end of the base **1706** and along an inner portion of the base **1706**. Each of the grooves **1743** can be configured to receive one of the protrusions **1741**. One or more of the grooves **1743** can be a different size or shape from the other grooves **1743**. FIG. **17C** illustrates a perspective view of the battery **1704** engaged with the base **1706**.

[0189] The wireless monitor **1702** can include a wireless transceiver capable of transmitting data using any of a variety of wireless technologies, such as Wi-Fi (802.11x), Bluetooth (802.15.2), Zigbee (802.15.4), cellular telephony, infrared, RFID, satellite transmission, proprietary protocols, combinations of the same, and the like.

[0190] As described above, any of the wireless monitoring systems described herein can include an accelerometer or gyroscope that can be used to detect one or more of patient orientation, patient movement, whether the patient is falling, or the like. In certain aspects, the wireless monitoring

system can include an alert system to alert the care giver that the patient is falling, getting out of bed, or otherwise moving in a prohibited manner. The alert can be an audible and/or visual alarm on the monitoring system or transmitted to a caregiver (e.g., nurses' station, pager, home computer, or otherwise).

[0191] In certain aspects, the information received by the accelerometer or gyroscope can be used to create an indication and/or animation of patient movement. This animation can be displayed on the patient monitor or transmitted to a nurses station or other off-site location to enable the care giver to monitor the patient. The animation can be viewed real time and/or be recorded for playback. For example, if an alarm alerts the care giver that the patient has fallen out of bed, the care giver can be presented playbacks of one or more of the patient's movement during that period of time.

[0192] FIGS. **18A-18C** illustrate examples of the animation that can be displayed on a bedside monitor, nurses' station monitor, or other display screen. FIG. **18A** illustrates a patient lying in bed **1801**, and the patient rolling over **1803**. FIG. **18B** illustrates the patient lying in bed **1805**, and the patient sitting up **1807**. FIG. **18C** illustrates the patient lying in bed **1809**, and the patient getting out of bed **1811**. Other patient movements can also be illustrated, such as a patient falling, walking, or otherwise. Depending on the embodiment, certain acts, events, or functions of any of the methods described herein can be performed in a different sequence, can be added, merged, or left out altogether (e.g., not all described acts or events are necessary for the practice of the method). Moreover, in certain embodiments, acts or events can be performed concurrently, e.g., through multi-threaded processing, interrupt processing, or multiple processors, rather than sequentially.

[0193] The various illustrative logical blocks, modules, circuits, and algorithm steps described in connection with the embodiments disclosed herein can be implemented as electronic hardware, computer software, or combinations of both. To clearly illustrate this interchangeability of hardware and software, various illustrative components, blocks, modules, circuits, and steps have been described above generally in terms of their functionality. Whether such functionality is implemented as hardware or software depends upon the particular application and design constraints imposed on the overall system. The described functionality can be implemented in varying ways for each particular application, but such implementation decisions should not be interpreted as causing a departure from the scope of the disclosure.

[0194] The various illustrative logical blocks, modules, and circuits described in connection with the embodiments disclosed herein can be implemented or performed with a general purpose processor, a digital signal processor (DSP), an application specific integrated circuit (ASIC), a field programmable gate array (FPGA) or other programmable logic device, discrete gate or transistor logic, discrete hardware components, or any combination thereof designed to perform the functions described herein. A general purpose processor can be a microprocessor, but in the alternative, the processor can be any conventional processor, controller, microcontroller, or state machine. A processor can also be implemented as a combination of computing devices, e.g., a combination of a DSP and a microprocessor, a plurality of microprocessors, one or more microprocessors in conjunction with a DSP core, or any other such configuration.

[0195] The steps of a method or algorithm described in connection with the embodiments disclosed herein can be embodied directly in hardware, in a software module executed by a processor, or in a combination of the two. A software module can reside in RAM memory, flash memory, ROM memory, EPROM memory, EEPROM memory, registers, hard disk, a removable disk, a CD-ROM, or any other form of storage medium known in the art. An exemplary storage medium is coupled to the processor such the processor can read information from, and write information to, the storage medium. In the alternative, the storage medium can be integral to the processor. The processor and the storage medium can reside in an ASIC. The ASIC can reside in a user terminal. In the alternative, the processor and the storage medium can reside as discrete components in a user terminal.

[0196] Conditional language used herein, such as, among others, “can,” “may,” “might,” “could,” “e.g.,” and the like, unless specifically stated otherwise, or otherwise understood within the context as used, is generally intended to convey that certain embodiments include, while some embodiments do not include, certain features, elements and/or steps. Thus, such conditional language is not generally intended to imply that features, elements and/or steps are in any way required for one or more embodiments or that one or more embodiments necessarily include logic for deciding, with or without author input or prompting, whether these features, elements and/or steps are included or are to be performed in any particular embodiment.

[0197] While the above detailed description has shown, described, and pointed out novel features as applied to various embodiments, it will be understood that various omissions, substitutions, and changes in the form and details of the device or process illustrated can be made without departing from the spirit of the disclosure. As will be recognized, certain embodiments of the inventions described herein can be embodied within a form that does not provide all of the features and benefits set forth herein, as some features can be used or practiced separately from others. The scope of the inventions is indicated by the appended claims rather than by the foregoing description. All changes which come within the meaning and range of equivalency of the claims are to be embraced within their scope.

1. A wireless patient monitoring system configured to improve battery performance, the wireless patient monitoring system comprising:

- a battery;
- an optical sensor configured to obtain photoplethysmographs, the optical sensor including at least one emitter configured to emit light and at least one detector configured to detect said light after attenuation by tissue of a user, said photoplethysmographs responsive to said detected light;
- a sensor signal processor configured to at least partially process said photoplethysmographs received from the optical sensor; and
- a wireless transmitter configured to wirelessly transmit said at least partially processed photoplethysmographs to a second device including a display, a user interface and a device signal processor, the second device configured to receive said at least partially processed photoplethysmographs, the device signal processor configured to further process said at least partially processed photoplethysmographs, said further process-

ing includes determining one or more physiological measurements responsive to said at least partially processed photoplethysmographs, the second device further configured to display said one or more physiological measurements on said display.

2. The system of claim 1, wherein the sensor signal processor is configured to perform bandpass filtering.

3. The system of claim 1, wherein the sensor signal processor is configured to perform signal conditioning.

4. The system of claim 1, wherein the one or more physiological measurements comprises an oxygen saturation, a pulse rate, and/or a perfusion index.

5. The system of claim 1, wherein the wireless transmitter is configured to wirelessly transmit said at least partially processed photoplethysmographs over Bluetooth.

6. The system of claim 1, further comprising an audible indicator configured to be activated when the physiological measurements are irregular.

7. The system of claim 1, wherein the optical sensor is configured to be coupled to a fingertip.

8. The system of claim 1, further comprising an adhesive for attaching the optical sensor to a user's skin.

9. The system of claim 1, further comprising a band configured to secure the system to the user.

10. A system comprising:

a sensor assembly comprising:

- a battery;
- an optical sensor configured to obtain photoplethysmographs, the optical sensor including at least one emitter configured to emit light and at least one detector configured to detect said light after attenuation by tissue of a user, said photoplethysmographs responsive to said detected light;

a sensor signal processor configured to at least partially process said photoplethysmographs received from the optical sensor;

a wireless transmitter configured to wirelessly transmit said at least partially processed photoplethysmographs to a second device; and

the second device comprising a processor, memory, and display, the memory storing computer-executable instructions that, when executed, cause the second device to:

further process said at least partially processed photoplethysmographs received from the sensor assembly to determine one or more physiological measurements responsive to said at least partially processed photoplethysmographs;

display a numerical value of said physiological measurements on the display; and

display a waveform representative of said physiological measurements on the display.

11. The system of claim 10, wherein the sensor signal processor is configured to perform bandpass filtering.

12. The system of claim 10, wherein the sensor signal processor is configured to perform signal conditioning.

13. The system of claim 10, wherein, when executed, the computer-executable instructions cause the second device to display a trend in said physiological measurements on the display.

14. The system of claim 10, wherein, when executed, the computer-executable instructions cause the second device to assemble a database including said physiological measurements.

15. The system of claim **10**, wherein, when executed, the computer-executable instructions cause the second device to wirelessly transmit said physiological measurements via email or text message.

16. A method of wirelessly monitoring physiological information, the method comprising:

securing an optical sensor to a user's skin, the optical sensor including at least one emitter configured to emit light and at least one detector configured to detect said light after attenuation by tissue of a user;

collecting photoplethysmographs from the optical sensor; at least partially processing said photoplethysmographs received from the optical sensor; and

wirelessly transmitting said at least partially processed photoplethysmographs to a second device; and

further processing said at least partially processed photoplethysmographs using the second device to deter-

mine one or more physiological measurements responsive to said at least partially processed photoplethysmographs.

17. The method of claim **16**, further comprising displaying a numerical value of said physiological measurements on a display device.

18. The method of claim **16**, further comprising displaying a waveform representative of said physiological measurements on a display device.

19. The method of claim **16**, further comprising displaying a trend in said physiological measurements on a display device.

20. The method of claim **16**, wherein collecting photoplethysmographs comprises continuously collecting said photoplethysmographs over a period of time.

* * * * *

专利名称(译)	无线患者监护设备		
公开(公告)号	US20190231241A1	公开(公告)日	2019-08-01
申请号	US16/182427	申请日	2018-11-06
[标]申请(专利权)人(译)	梅西莫股份有限公司		
申请(专利权)人(译)	Masimo公司		
当前申请(专利权)人(译)	Masimo公司		
[标]发明人	AL ALI AMMAR KINAST ERIC KARL MUHSIN BILAL DEJONG CHAD A		
发明人	AL-ALI, AMMAR KINAST, ERIC KARL MUHSIN, BILAL DEJONG, CHAD A.		
IPC分类号	A61B5/1455 A61B5/0295 A61B5/00 A61B5/026		
CPC分类号	A61B5/14552 A61B5/0295 A61B5/002 A61B5/7405 A61B5/6826 A61B5/6833 A61B5/6831 A61B5/7425 A61B5/725 A61B5/0261 A61B5/746 A61B2560/0214 A61B5/0024 A61B5/02416 A61B5/14551 A61B2560/0266 A61B2560/0475 G16H10/60 G16H40/20 G16H40/63 A61B5/0022 A61B5/0059 A61B5/7445		
优先权	61/597126 2012-02-09 US 61/625584 2012-04-17 US 61/703713 2012-09-20 US		
外部链接	Espacenet USPTO		

摘要(译)

一种用于获得医疗患者的生理信息并将获得的生理信息无线发送到无线接收器的设备。

