



US 20170086938A1

(19) **United States**

(12) **Patent Application Publication**
Mak et al.

(10) **Pub. No.: US 2017/0086938 A1**
(43) **Pub. Date: Mar. 30, 2017**

(54) **DEFORMABLE AND SHAPE-ABLE
SURGICAL LIGHTING DEVICE AND
SYSTEM**

(71) Applicant: **Synaptive Medical (Barbados) Inc.**,
Bridgetown (BB)

(72) Inventors: **Siu Wai Jacky Mak**, Toronto, Ontario
(CA); **Michael Frank Gunter Wood**,
Toronto, Ontario (CA)

(73) Assignee: **Synaptive Medical (Barbados) Inc.**,
Bridgetown (BB)

(21) Appl. No.: **14/899,254**

(22) PCT Filed: **Mar. 27, 2015**

(86) PCT No.: **PCT/CA2015/050243**

§ 371 (c)(1),

(2) Date: **Dec. 17, 2015**

Publication Classification

(51) **Int. Cl.**
A61B 90/30 (2006.01)
A61B 5/00 (2006.01)
A61B 1/06 (2006.01)

(52) **U.S. Cl.**
CPC *A61B 90/30* (2016.02); *A61B 1/0638*
(2013.01); *A61B 5/0071* (2013.01); *A61B*
5/0075 (2013.01); *A61B 5/0084* (2013.01);
A61B 2090/306 (2016.02)

(57) **ABSTRACT**

The present disclosure provides a conductor-less, shape-able surgical lighting system for use in surgical applications in which a medical clinician, once having established a surgical site, can shape the lighting system to selectively illuminate desired volumes of the surgical site. The system includes one or more preselected lengths of an elongate light emitting member formed of a transparent elastomer matrix material having a glass transition temperature of lower than or substantially equal to room temperature to render the elongate light emitting member bendable and shape-able. Embedded in the transparent elastomer matrix material are particles of a transparent material having a refractive index different from a refractive index of the matrix material dispersed in the elastomer matrix material so that light coupled into the elongate light emitting member is scattered and refracted out of the elongate light emitting member along its length. One end of the elongate light emitting member configured to be coupled to a light source.

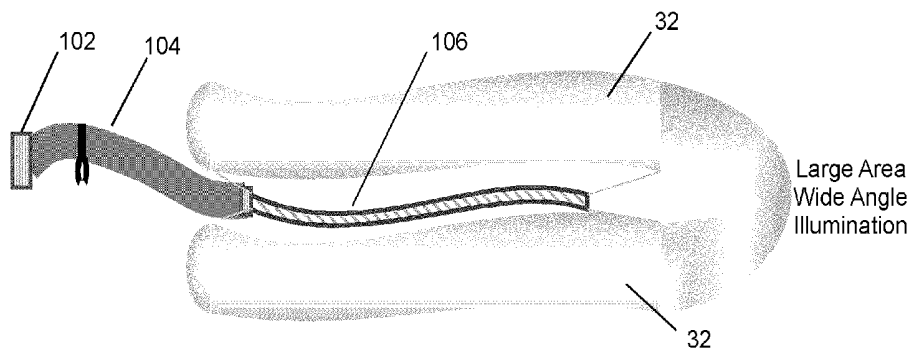

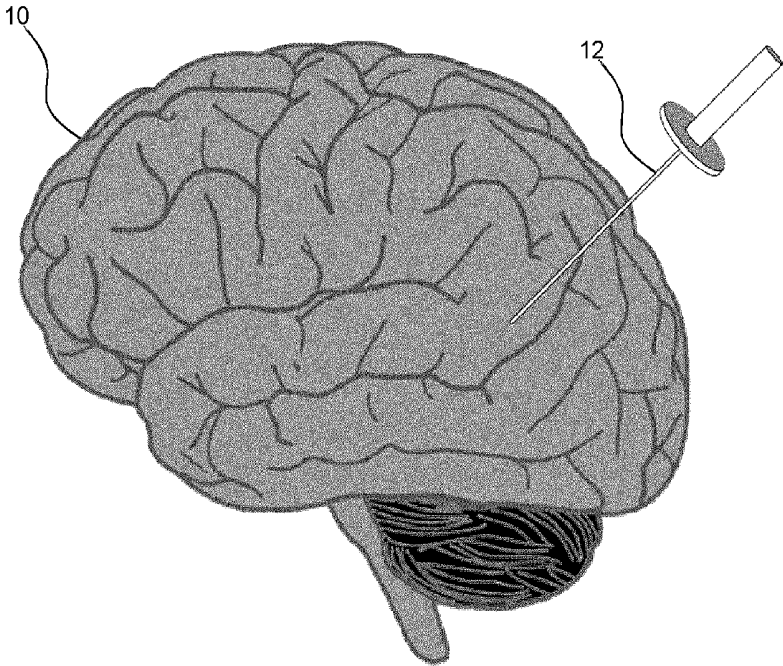

FIG. 1

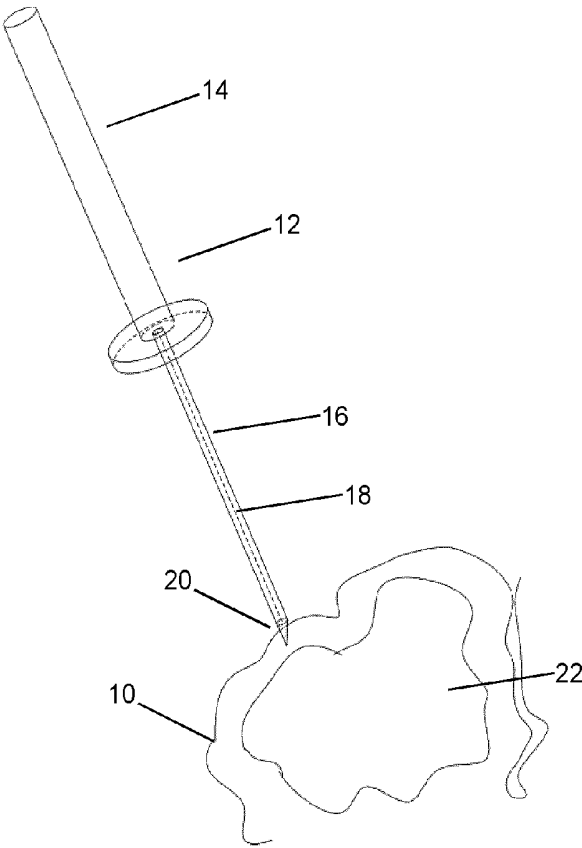

FIG. 2

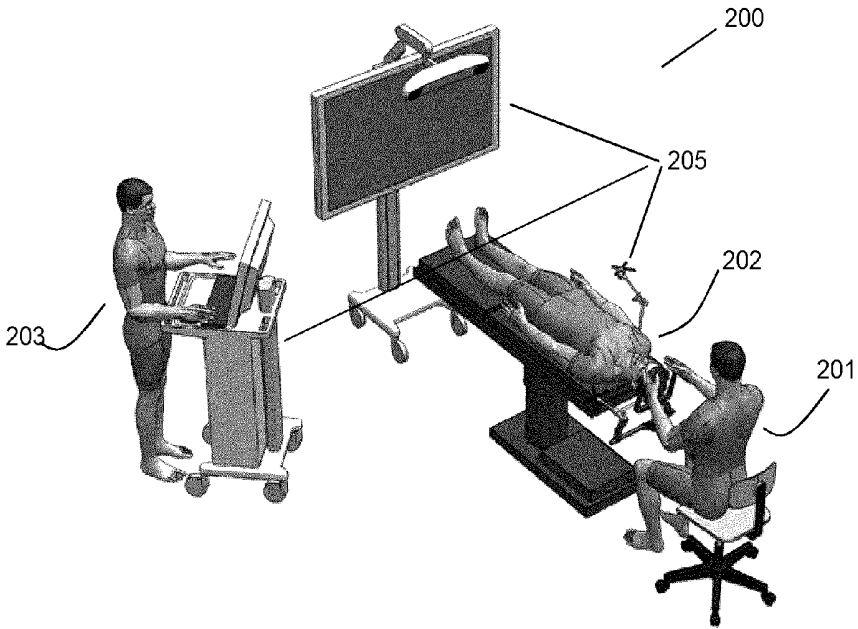

FIG. 3A

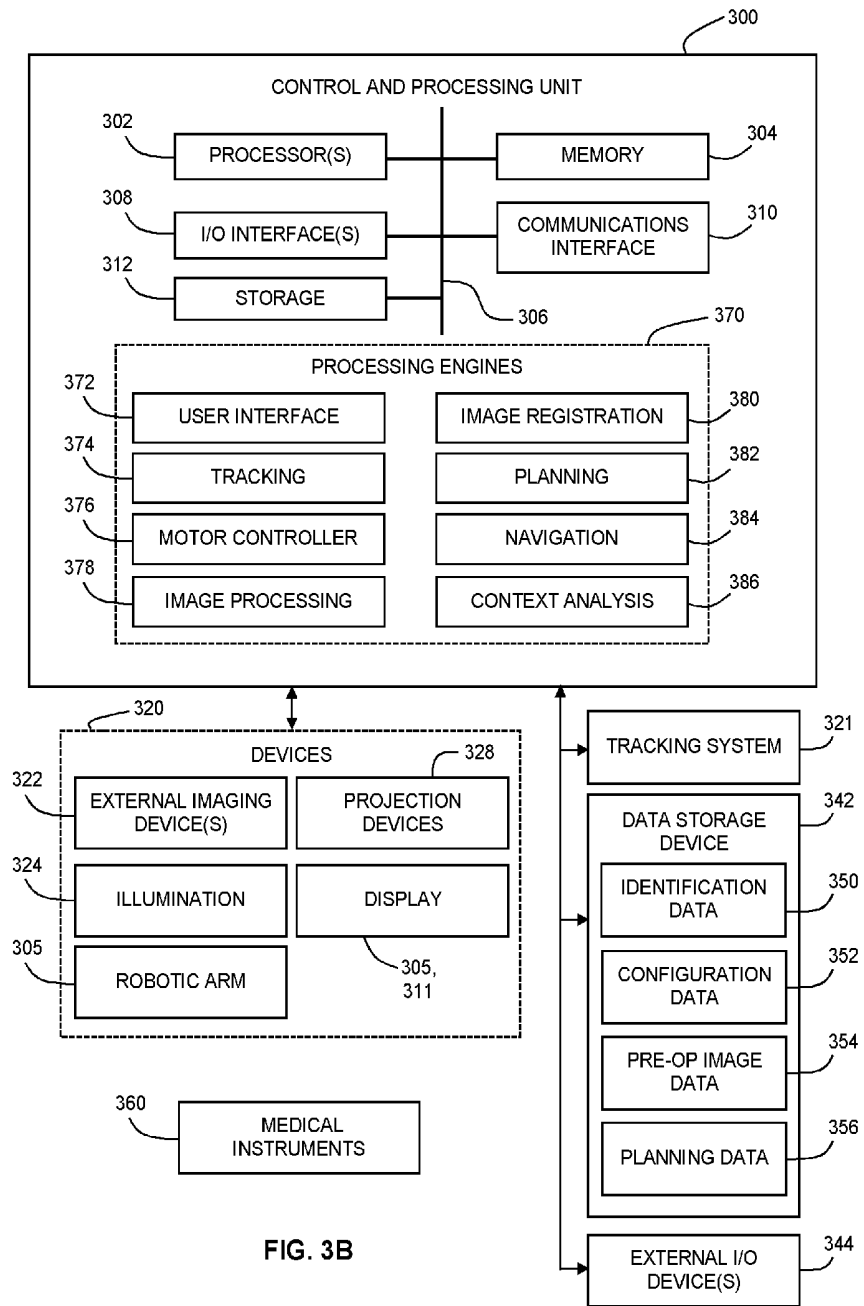

FIG. 3B

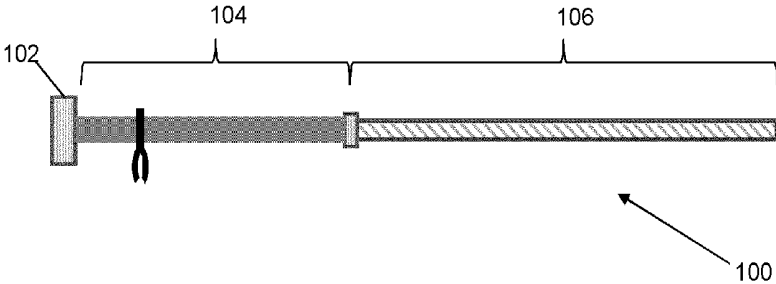

FIG. 4A

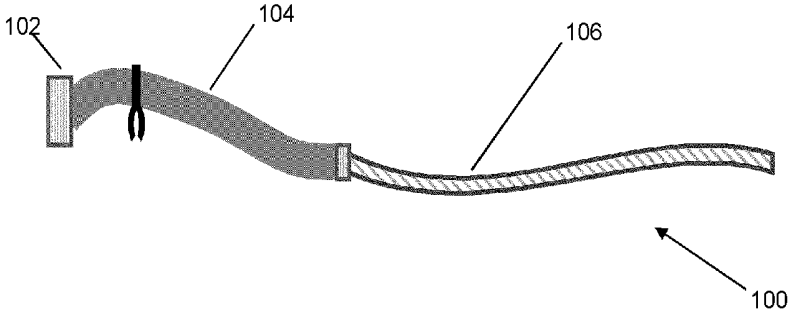

FIG. 4B

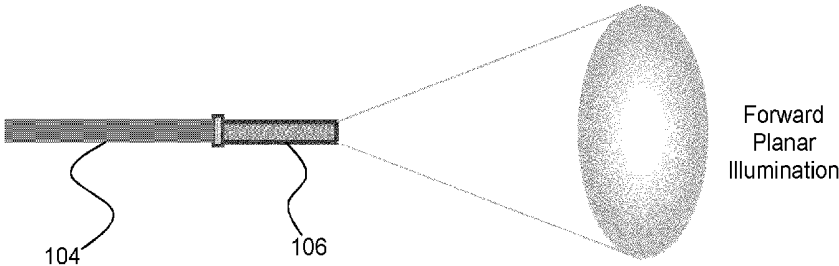

FIG. 5A

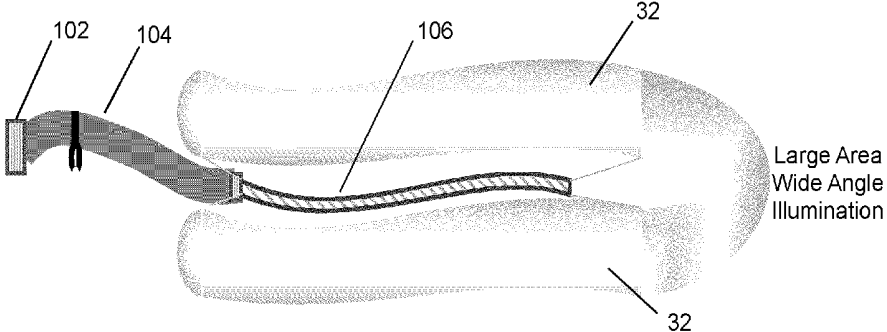

FIG. 5B

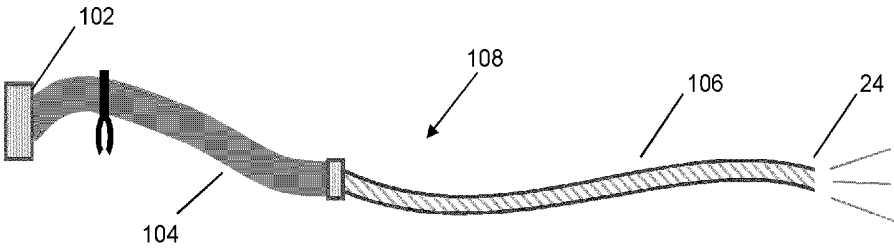

FIG. 6A

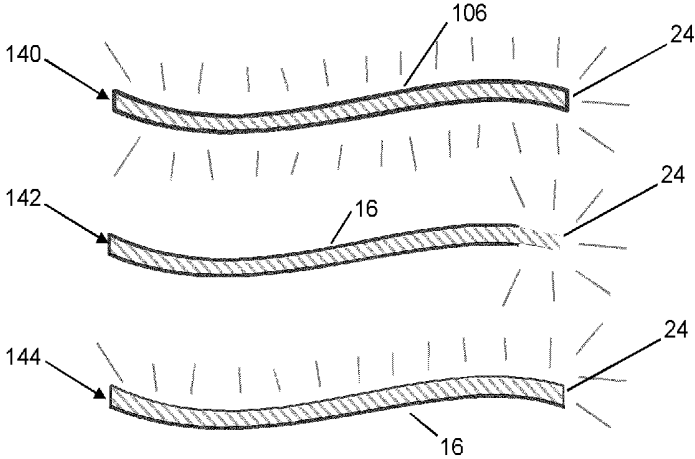

FIG. 6B

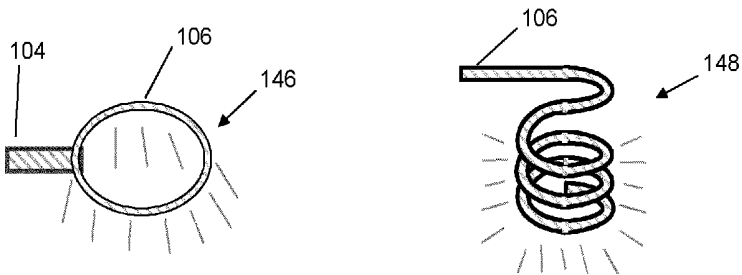

FIG. 6C

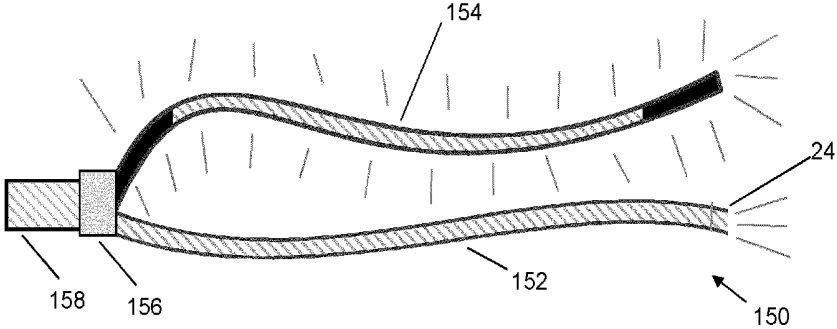

FIG. 6D

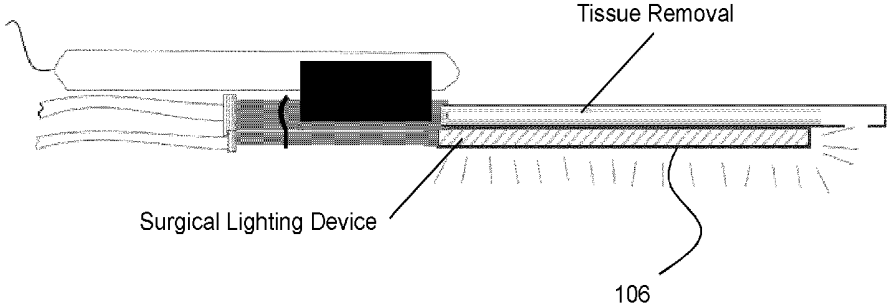

FIG. 7A

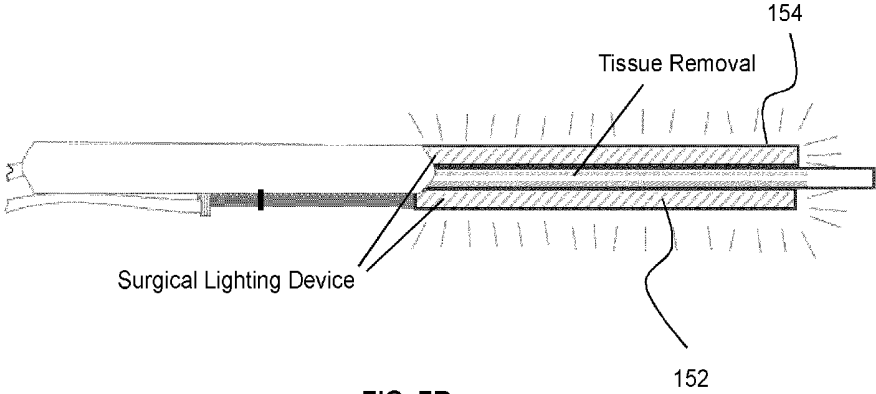

FIG. 7B

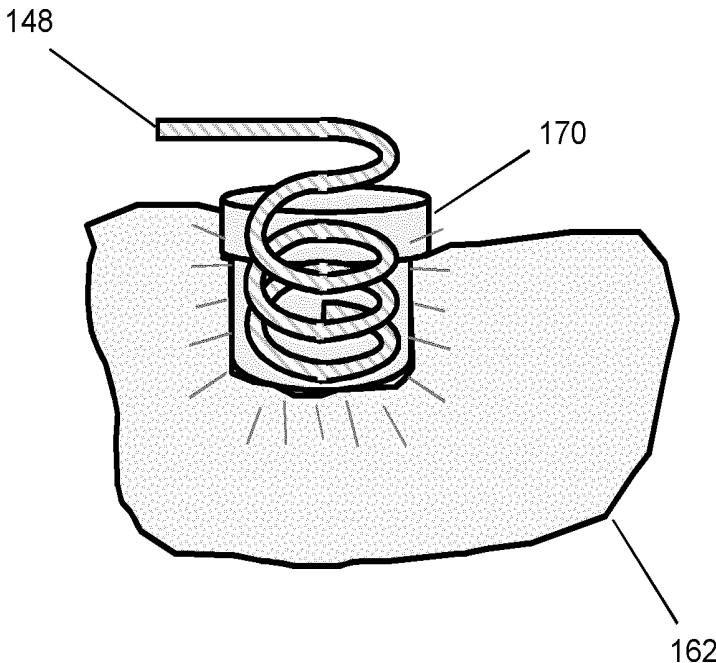

FIG. 8

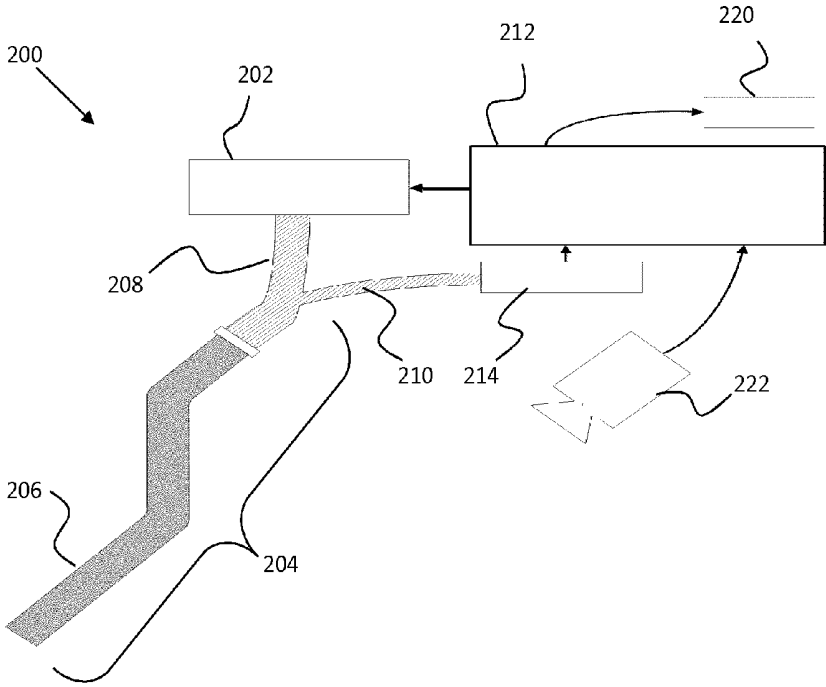

FIG. 9

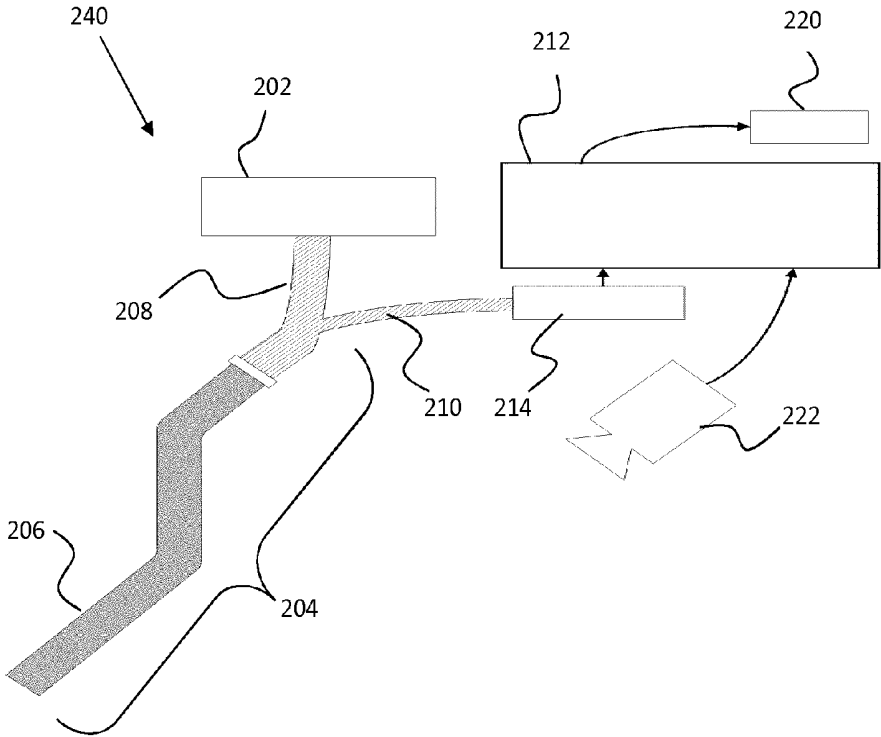
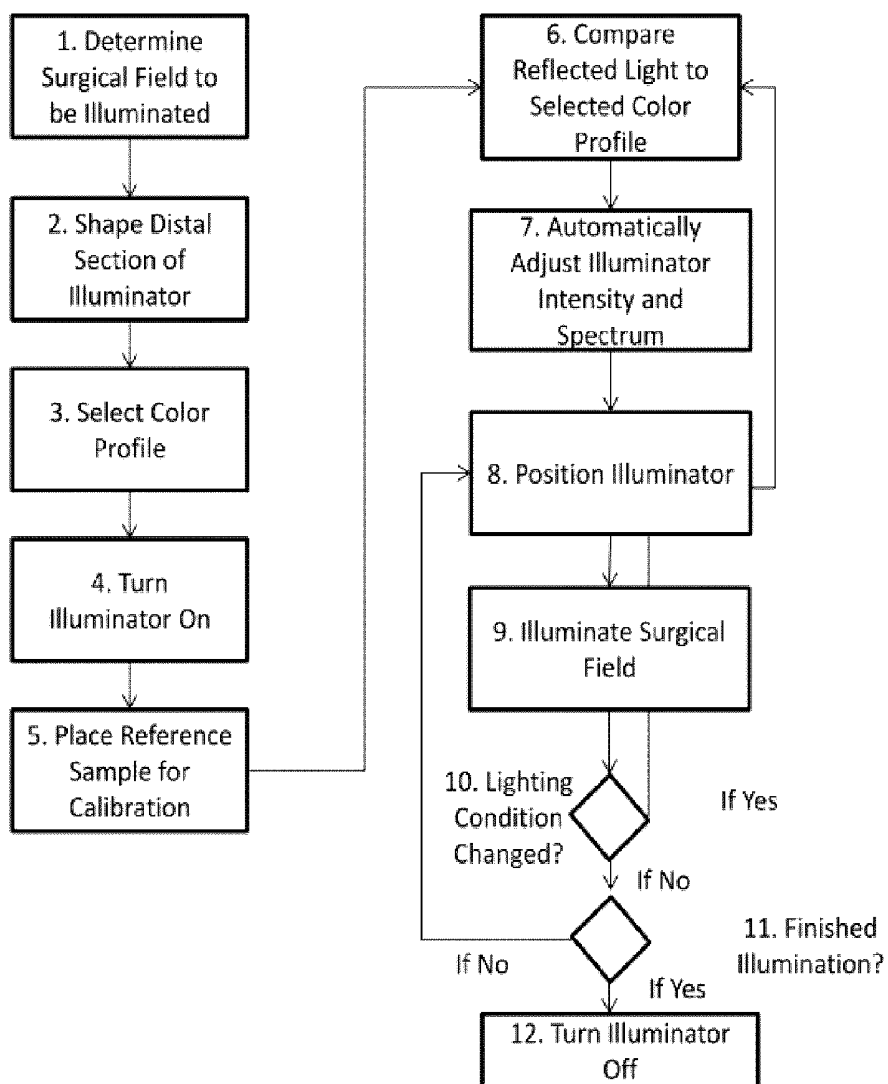
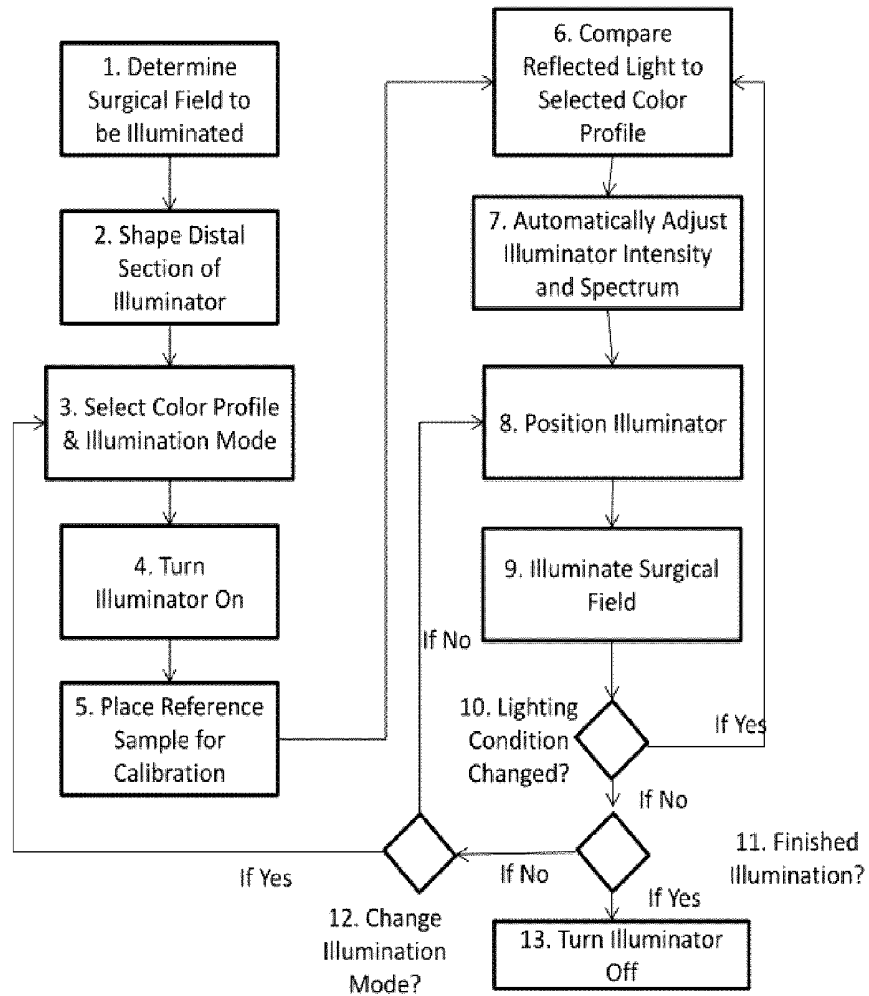

FIG. 10



Flow Chart 1

FIG. 11



Flow Chart 2

FIG. 12

DEFORMABLE AND SHAPE-ABLE SURGICAL LIGHTING DEVICE AND SYSTEM

FIELD

[0001] The present disclosure relates to a clinician deformable, shape-able light source for surgical applications.

BACKGROUND

[0002] In many current surgeries, surgical illuminator(s) is/are commonly used to provide additional lighting to the surgical field in addition to the surgical lighting (i.e. large lighting fixtures) in the operation room. Currently there are two types of surgical illuminators, namely standalone illuminators and tool-integrated illuminators.

[0003] The standalone illuminators have a forward illumination scheme in which light shines only in the forward direction from typically the tip of the illuminator to the surgical field. When the surgeon positions the illuminator, they deliver light at a limited illumination angle and the field of illumination is typically planer. As a result, they are typically used from the side or on top of the surgical field to illuminate area that the illuminator is pointing towards. In cases when illumination of a large or deep surgical field is required, such as the case in port-based brain surgeries, these illuminators cannot illuminate the entire surgical field with enough brightness. Surgeons often have to re-position the illuminator to focus the illumination at the field of interest during the surgery. This process is cumbersome and time-consuming as the surgeon needs to re-position the illuminator constantly to observe the entire surgical field. In some cases, the surgeon also needs to drop the surgical tool in his hand to re-position the illuminator.

[0004] Examples of standalone illuminators are found at the websites set out below:

[0005] (a) Fiber optic based surgical illuminator:

[0006] <http://www.svnthes.com/MediaBin/US%20DATA/Product%20Support%20Materials/Technique%20Guides/SPTGInsightAccessRetractorJ9680B.pdf> (Page 5)

[0007] This illuminator is comprised of an elongated light cable enclosed by a snake tube that enables the light cable to hold its shape as it is bent, a clamp that positions the illuminator with a connector that connects to a light source through a fiber optic light cable, and an opening at the distal end of the illuminator that provides illumination in the forward scheme.

[0008] (b) Headlight:

[0009] <http://intl.welchallyn.com/apps/products/product.jsp?id=16-in-96-1190684508766>

[0010] This headlight illuminator is comprised of a holder that enables one to wear the illuminator on the head, an illuminator head that connects to a light source through a fiber optic light cable and a mechanical joint that fixes the illuminator head to illuminate light in the forward direction in which the user is looking.

[0011] To provide a more effective lighting solution, tool-integrated illuminators have been developed. These illuminators are designed to deliver lighting in a way that is best suited for a surgical procedure. Often, they are partly or

completely integrated with the surgical tool to achieve a few goals: (1) hands-free illumination (i.e. surgeon does not have to hold a separate illuminator), (2) more effective illumination (i.e. putting illuminator closer to the field-of-interest for more effective light delivery), (3) custom light field (i.e. providing an area or a way of illumination that is best suited for a surgical procedure. For example, these illuminators could be, but not limited to, a ring or a curved illuminator made for avoiding shadows and/or optimizing lighting at specific areas of the surgical field. These illuminators could also provide a forward illumination scheme that is integrated with the surgical tool. A limitation of these illuminators is that they are only suitable for certain surgical procedures since they are optimized for a surgical procedure and integrated with a specific tool. Moreover, the illumination direction and position of the illuminator is fixed with respect to the tool. These settings might not be ideal for every surgeon and cannot be adjusted to suit each surgeon's needs.

[0012] Examples of tool-integrated illuminators:

[0013] (a) Vitom—Ring illuminators

[0014] The Vitom is a surgical microscope that integrates fiber optic around the imaging lenses to provide illumination down toward the surgical region of interest in a forward scheme. The Vitom comprises of an eyepiece that enables connection to a camera, a connector on the side that connects to a light source through a fiber optic cable, and an elongated body that comprises of lens for imaging and fiber optics around the lens for illumination.

[0015] (b) Ortho-Light:

[0016] <http://www.lumitex.com/medical-devices/products/ortholight/ortho-light/>

[0017] Ortho-Light is a fiber optic panel that attaches to retractors for illumination in the forward direction and in the side.

[0018] (c) Retractors Illumination: <http://www.invuity.com/products/eikon-retractor-system/>

[0019] This illuminator integrated an optical light guide in front of the retractor for illumination in mostly the downward direction.

[0020] In addition, if surgical camera is used, the color of the surgical field being displayed on the monitor changes between surgery, illuminators, and the surrounding lighting in the environment. This color often deviates from the true native color that the human eyes see and/or the preferential color that surgeons use for surgery. A spectrometer could be used to correct the color of the image being display before the surgery. However, high color precision highly depends on the actual lighting condition which changes with the type, position, shape and number of the illuminator. Therefore, it is best to correct the image color at the surgical field dynamically.

[0021] It would be very advantageous to provide a clinician deformable, shape-able light source with an integrated color correction sensor for surgical applications.

SUMMARY

[0022] The present disclosure provides a non-rigid, bendable surgical lighting system for use in surgical applications in which a medical clinician, once having established a surgical site, can shape, by bending, the lighting system to selectively illuminate desired volumes of the surgical site.

[0023] In an embodiment, the lighting system includes one or more elongate light emitting member formed of a trans-

parent elastomer matrix material having a glass transition temperature of lower than or substantially equal to room temperature to render the elongate light emitting member bendable and shape-able. Embedded in the transparent elastomer matrix material are particles of a transparent material having a refractive index different from a refractive index of the matrix material dispersed in the elastomer matrix material so that light coupled into the elongate light emitting member is scattered and refracted out of the elongate light emitting member along its length. A proximal end of the one or more elongate light emitting members are configured to be coupled to a light source and to a spectrometer. The length of the one or more elongate light emitting members is selected so that a medical clinician, can bend and shape it to provide a desired level of lighting of the anatomical surgical site while accommodating surgical instruments present in the anatomical surgical site. The spectrometer will connect to computer that takes the color spectrum from the spectrometer and corrects the color spectrum of the output image from a surgical camera through comparison with a standard color reference or color profiles.

[0024] The system may include one preselected length of the elongate light emitting member which is long enough to be shaped to the illuminate the desired areas of the surgical site, accounting for having to be wrapped around various surgical instruments, such as a port used during brain surgery.

[0025] Alternatively, the surgical lighting system may include multiple elongate light emitting members each having an end adapted to be coupled to the light source which can be shaped independently of the other lengths.

[0026] The outer surfaces of one or more sections of the elongate lengths may be masked, for example with a reflective coating, to selectively illuminate particular areas of the surgical site, with the reflective coating acting to reflect light back from the coating out of the uncoated areas to increase illumination intensity to the desired locations.

[0027] The surgical lighting system may be integrated with one or more surgical tools, such as a resection tool or an access port, through a clamp on the system, or through deforming the lighting system to fit into or hold onto the tool.

[0028] Thus, an embodiment disclosed herein includes a flexible, adaptive surgical lighting system, comprising:

[0029] a) non-rigid, bendable surgical lighting system including one or more elongate light emitting members;

[0030] b) a light source, a proximal end of said one or more elongate light emitting members configured to be coupled to said light source;

[0031] c) a spectrometer, a computer processor connected to said spectrometer, said light source connected to said spectrometer, a camera connected to said computer processor, a visual display connected to said computer processor;

[0032] d) said spectrometer being configured to receive light reflected from an anatomical surgical site;

[0033] e) said computer processor being programmed with instructions for

[0034] i) receiving a reflected light intensity and color spectrum of the reflected light from the spectrometer, displaying it and to comparing it to a pre-selected color profile standard, and, based on differences between said reflected light intensity and color spectrum and said

pre-selected color profile standard, adaptively adjust the light intensity and color spectrum of the displayed image; and

[0035] ii) visually displaying the adjusted light intensity and color spectrum of the light received from the anatomical surgical site.

[0036] Another embodiment provides a method of controlling illumination of a surgical site, comprising:

[0037] a) shaping a distal end of a flexible and bendable surgical lighting member which includes one or more elongate light emitting and collecting members;

[0038] b) connecting a light source to a proximal end of said one or more elongate light emitting members, optically coupling a spectrometer to said light source, connecting a computer processor to said spectrometer, connecting a camera to said computer processor and connecting a visual display to said computer processor;

[0039] c) directing light emitted from said one or more elongate light emitting and collecting members to a surgical site and collecting light reflected from said surgical site by said one or more elongate light emitting and collecting members and directing the collected reflected light into said spectrometer;

[0040] d) directing a reflected light intensity and color spectrum of the reflected light from the spectrometer to the microprocessor and displaying it and comparing it to a pre-selected color profile standard, and, based on differences between said reflected light intensity and color spectrum and said pre-selected color profile standard, adaptively adjusting the light intensity and color spectrum of the displayed image; and

[0041] e) visually displaying the adjusted light intensity and color spectrum of the light received from the anatomical surgical site.

[0042] A further understanding of the functional and advantageous aspects of the present disclosure can be realized by reference to the following detailed description and drawings.

BRIEF DESCRIPTION OF THE DRAWINGS

[0043] Embodiments will now be described, by way of example only, with reference to the drawings, in which:

[0044] FIG. 1 illustrates the insertion of an access port into a human brain, for providing access to internal brain tissue during a medical procedure;

[0045] FIG. 2 illustrates the insertion of a catheter as an access port into the brain;

[0046] FIG. 3A shows an exemplary navigation system to support minimally invasive access port-based surgery;

[0047] FIG. 3B is a block diagram illustrating a control and processing system that may be used in the navigation system shown in FIG. 3A;

[0048] FIG. 4A is a side view of a deformable surgical lighting device constructed according to the present invention including an elongate deformable illumination section for illuminating the volume of interest, a holder section which can be held by the clinician and a coupler section for coupling the lighting device to a light source, with the device shown fully extended and straight.

[0049] FIG. 4B shows the lighting system of FIG. 4A deformed and shaped in a non linear manner.

[0050] FIG. 5A shows an embodiment of the lighting system similar to the system of FIGS. 4A and 4B but having

a coating over the elongate section so light is only emitted out the distal end of the elongate section to give forward planar illumination.

[0051] FIG. 5B shows an embodiment of the lighting system similar to the system of FIGS. 4A and 4B which is uncoated all along its length to give large area wide angle illumination.

[0052] FIGS. 6A to 6D illustrates several different embodiments of the present lighting system.

[0053] FIGS. 7A and B illustrate several different exemplary embodiments of integrating the lighting system with a surgical tool.

[0054] FIG. 8 illustrates an exemplary embodiment of integrating the lighting system with an access port.

[0055] FIG. 9 shows a block diagram of a first embodiment of a feedback surgical lighting system forming part of the present disclosure.

[0056] FIG. 10 shows a block diagram of a second embodiment of a feedback surgical lighting system forming part of the present disclosure.

[0057] FIG. 11 shows a Flow Chart 1 showing an embodiment of steps in the present system and method.

[0058] FIG. 12 shows a Flow Chart 2 showing another embodiment of steps in the present system and method.

DETAILED DESCRIPTION

[0059] Various embodiments and aspects of the disclosure will be described with reference to details discussed below. The following description and drawings are illustrative of the disclosure and are not to be construed as limiting the disclosure. Numerous specific details are described to provide a thorough understanding of various embodiments of the present disclosure. However, in certain instances, well-known or conventional details are not described in order to provide a concise discussion of embodiments of the present disclosure.

[0060] As used herein, the terms, “comprises” and “comprising” are to be construed as being inclusive and open ended, and not exclusive. Specifically, when used in the specification and claims, the terms, “comprises” and “comprising” and variations thereof mean the specified features, steps or components are included. These terms are not to be interpreted to exclude the presence of other features, steps or components.

[0061] As used herein, the term “exemplary” means “serving as an example, instance, or illustration,” and should not be construed as preferred or advantageous over other configurations disclosed herein.

[0062] As used herein, the terms “about” and “approximately” are meant to cover variations that may exist in the upper and lower limits of the ranges of values, such as variations in properties, parameters, and dimensions. In one non-limiting example, the terms “about” and “approximately” mean plus or minus 10 percent or less.

[0063] Unless defined otherwise, all technical and scientific terms used herein are intended to have the same meaning as commonly understood to one of ordinary skill in the art. Unless otherwise indicated, such as through context, as used herein, the following terms are intended to have the following meanings:

[0064] As used herein, the phrase “access port” refers to a cannula, conduit, sheath, port, tube, or other structure that is insertable into a subject, in order to provide access to internal tissue, organs, or other biological substances. In

some embodiments, an access port may directly expose internal tissue, for example, via an opening or aperture at a distal end thereof, and/or via an opening or aperture at an intermediate location along a length thereof. In other embodiments, an access port may provide indirect access, via one or more surfaces that are transparent, or partially transparent, to one or more forms of energy or radiation, such as, but not limited to, electromagnetic waves and acoustic waves.

[0065] As used herein the phrase “intraoperative” refers to an action, process, method, event or step that occurs or is carried out during at least a portion of a medical procedure. Intraoperative, as defined herein, is not limited to surgical procedures, and may refer to other types of medical procedures, such as diagnostic and therapeutic procedures.

[0066] Various apparatuses or processes will be described below to provide examples of embodiments of the invention. No embodiment described below limits any claimed invention and any claimed invention may cover processes or apparatuses that differ from those described below. The claimed inventions are not limited to apparatuses or processes having all of the features of any one apparatus or process described below or to features common to multiple or all of the apparatuses or processes described below. It is possible that an apparatus or process described below is not an embodiment of any claimed invention.

[0067] Furthermore, numerous specific details are set forth in order to provide a thorough understanding of the embodiments described herein. However, it will be understood by those of ordinary skill in the art that the embodiments described herein may be practiced without these specific details. In other instances, well known methods, procedures and components have not been described in detail so as not to obscure the embodiments described herein. Also, the description is not to be considered as limiting the scope of the embodiments described herein.

[0068] Furthermore, in the following passages, different aspects of the embodiments are defined in more detail. In particular, any feature indicated as being preferred or advantageous may be combined with at least one other feature or features indicated as being preferred or advantageous.

[0069] Embodiments of the present disclosure provide a deformable and/or shape-able lighting system which can be shape-configured to provide desired illumination, (direction, intensity and planar illumination shape) by a medical clinician. This deformable lighting system is very useful in certain types of surgery where various medical devices need to be inserted into the anatomical structures being operated on. For example, embodiments of the present lighting system are useful in minimally invasive medical procedures that are performed via an access port, whereby surgery, diagnostic imaging, therapy, or other medical procedures (e.g. minimally invasive medical procedures) are performed based on access to internal tissue through the access port, in which illumination options are limited. The present lighting system may be integrated with a resection tool, through the clamp. This enables more efficient lighting through bringing the lighting system closer to the surgical field at regions where surgeon is operating on. In another example, the present lighting system may be integrated with the access port through deforming the lighting system into a cylindrical shape. The diameter of the cylindrical shape may be made similar or smaller than the inner diameter of the access port, which enables the lighting system to be placed into the

access port for illumination while leaving the center region of the access port open for surgical tool access.

[0070] An example of an access port is an intracranial conduit which may be employed in neurological procedures in order to provide access to internal tissue pathologies, such as tumors. One example of an intracranial access port is the BrainPath surgical access port provided by NICO, which may be inserted into the brain via an obturator with an atraumatic tip in the brain. Such an access port may be employed during a surgical procedure, by inserting the access port, via the obturator that is received within the access port, through the white matter fibers of the brain to access a surgical site.

[0071] Minimally invasive brain surgery using access ports is a recently conceived method of performing surgery on brain tumors previously considered inoperable. One object of the present invention is to provide a system and method to assist in minimally invasive brain surgery. To address intracranial surgical concerns, specific products such as the NICO BrainPath™ port have been developed for port-based surgery.

[0072] FIG. 1 illustrates the insertion of an access port into a human brain, for providing access to internal brain tissue during a medical procedure. In FIG. 1, access port 12 is inserted into a human brain 10, providing access to internal brain tissue. Access port 12 may include such instruments as catheters, surgical probes, or cylindrical ports such as the NICO BrainPath. Surgical tools and instruments may then be inserted within the lumen of the access port 12 in order to perform surgical, diagnostic or therapeutic procedures, such as resecting tumors as necessary. The present disclosure applies equally well to catheters, deep brain stimulation (DBS) needles, a biopsy procedure, and also to biopsies and/or catheters in other medical procedures performed on other parts of the body.

[0073] In the example of a port-based surgery, a straight or linear access port 12 is typically guided down a sulci path of the brain. Surgical instruments would then be inserted down the access port 12.

[0074] Optical tracking systems, used in the medical procedure, track the position of a part of the instrument that is within line-of-site of the optical tracking camera. Since the tip of the surgical instrument may be inserted within a patient, line of site to the tip of the instrument cannot always be maintained. As well, positioning the optical tracking mechanisms at the tip may be too cumbersome to be of practical use. Conventionally, the tip and orientation of the instrument is inferred through a known transformation (e.g., either measured or determined by manufactured drawings) from the visible tracked position to the tip position.

[0075] Referring to FIG. 2, the insertion of a catheter as an access port into the brain is shown. In FIG. 2, catheter 12 may be used as an access port positioned to navigate a human brain 10. Catheter 12 may include a handle 14 at the proximal end and a probe 16 at the distal end. In one example, the probe 16 may be substantially straight or linear; however curved probes could also be used. Probe 18 may be a resection tool, an image sensor and/or other types of sensing tools that can take measurements in different imaging modalities (e.g., ultrasound, Raman, optical coherence tomography (OCT), positron emission tomography (PET), magnetic resonance imaging (MRI), etc.). Probe 16 may be hollow thus providing an internal passage 18 through which fluids or wires may be passed.

[0076] Probe 18 may enter the brain 10 and be navigated to targeted internal tissue 22. In one example, the probe 16 may follow sulci path 20, however, due to the typically linear nature of probe 16, a linear path to targeted internal tissue 22 is usually mapped out.

[0077] Referring to FIG. 3A, an exemplary navigation system environment 200 is shown, which may be used to support navigated image-guided surgery. As shown in FIG. 3A, surgeon 201 conducts a surgery on a patient 202 in an operating room (OR) environment. A navigation system 205 comprising an equipment tower, tracking system, displays and tracked instruments assist the surgeon 201 during his procedure. An operator 203 is also present to operate, control and provide assistance for the navigation system 205.

[0078] Referring to FIG. 3B, a block diagram is shown illustrating a control and processing system 300 that may be used in the navigation system environment 200 shown in FIG. 3A (e.g., as part of the equipment tower). As shown in FIG. 3B, in one example, control and processing system 300 may include one or more processors 302, a memory 304, a system bus 306, one or more input/output interfaces 308, a communications interface 310, and storage device 312. Control and processing system 300 may be interfaced with other external devices, such as tracking system 321, data storage 342, and external user input and output devices 344, which may include, for example, one or more of a display, keyboard, mouse, foot pedal, and microphone and speaker. Data storage 342 may be any suitable data storage device, such as a local or remote computing device (e.g. a computer, hard drive, digital media device, or server) having a database stored thereon. In the example shown in FIG. 3B, data storage device 342 includes identification data 350 for identifying one or more medical instruments 360 and configuration data 352 that associates customized configuration parameters with one or more medical instruments 360. Data storage device 342 may also include preoperative image data 354 and/or medical procedure planning data 356. Although data storage device 342 is shown as a single device in FIG. 3B, it will be understood that in other embodiments, data storage device 342 may be provided as multiple storage devices.

[0079] Medical instruments 360 are identifiable by control and processing unit 300. Medical instruments 360 may be connected to and controlled by control and processing unit 300, or medical instruments 360 may be operated or otherwise employed independent of control and processing unit 300. Tracking system 321 may be employed to track one or more of medical instruments 360 and spatially register the one or more tracked medical instruments to an intraoperative reference frame. In another example, as sheath placed over a medical instrument 360 may be connected to and controlled by control and processing unit 300.

[0080] Control and processing unit 300 may also interface with a number of configurable devices, and may intraoperatively reconfigure one or more of such devices based on configuration parameters obtained from configuration data 352. Examples of devices 320, as shown in FIG. 3B, include one or more external imaging devices 322, one or more illumination devices 324, a robotic arm, one or more projection devices 328, and one or more displays 205, 211.

[0081] Exemplary aspects of the disclosure can be implemented via processor(s) 302 and/or memory 304. For example, the functionalities described herein can be partially

implemented via hardware logic in processor 302 and partially using the instructions stored in memory 304, as one or more processing modules or engines 370. Example processing modules include, but are not limited to, user interface engine 372, tracking module 374, motor controller 376, image processing engine 378, image registration engine 380, procedure planning engine 382, navigation engine 384, and context analysis module 386. While the example processing modules are shown separately in FIG. 3B, in one example the processing modules 370 may be stored in the memory 304 and the processing modules may be collectively referred to as processing modules 370.

[0082] It is to be understood that the system is not intended to be limited to the components shown in FIG. 3B. One or more components of the control and processing system 300 may be provided as an external component or device. In one example, navigation module 384 may be provided as an external navigation system that is integrated with control and processing system 300.

[0083] Some embodiments may be implemented using processor 302 without additional instructions stored in memory 304. Some embodiments may be implemented using the instructions stored in memory 304 for execution by one or more general purpose microprocessors. Thus, the disclosure is not limited to a specific configuration of hardware and/or software.

[0084] While some embodiments can be implemented in fully functioning computers and computer systems, various embodiments are capable of being distributed as a computing product in a variety of forms and are capable of being applied regardless of the particular type of machine or computer readable media used to actually effect the distribution.

[0085] At least some aspects disclosed can be embodied, at least in part, in software. That is, the techniques may be carried out in a computer system or other data processing system in response to its processor, such as a microprocessor, executing sequences of instructions contained in a memory, such as ROM, volatile RAM, non-volatile memory, cache or a remote storage device.

[0086] A computer readable storage medium can be used to store software and data which, when executed by a data processing system, causes the system to perform various methods. The executable software and data may be stored in various places including for example ROM, volatile RAM, nonvolatile memory and/or cache. Portions of this software and/or data may be stored in any one of these storage devices.

[0087] Examples of computer-readable storage media include, but are not limited to, recordable and non-recordable type media such as volatile and non-volatile memory devices, read only memory (ROM), random access memory (RAM), flash memory devices; floppy and other removable disks, magnetic disk storage media, optical storage media (e.g., compact discs (CDs), digital versatile disks (DVDs), etc.), among others. The instructions may be embodied in digital and analog communication links for electrical, optical, acoustical or other forms of propagated signals, such as carrier waves, infrared signals, digital signals, and the like. The storage medium may be the internet cloud, or a computer readable storage medium such as a disc.

[0088] At least some of the methods described herein are capable of being distributed in a computer program product comprising a computer readable medium that bears com-

puter usable instructions for execution by one or more processors, to perform aspects of the methods described. The medium may be provided in various forms such as, but not limited to, one or more diskettes, compact disks, tapes, chips, USB keys, external hard drives, wire-line transmissions, satellite transmissions, internet transmissions or downloads, magnetic and electronic storage media, digital and analog signals, and the like. The computer useable instructions may also be in various forms, including compiled and non-compiled code.

[0089] According to one aspect of the present application, one purpose of the navigation system 205, which may include control and processing unit 300, is to provide tools to the neurosurgeon that will lead to the most informed, least damaging neurosurgical operations. In addition to removal of brain tumours and intracranial hemorrhages (ICH), the navigation system 205 can also be applied to a brain biopsy, a functional/deep-brain stimulation, a catheter/shunt placement procedure, open craniotomies, endonasal/skull-based/ENT, spine procedures, and other parts of the body such as breast biopsies, liver biopsies, etc. While several examples have been provided, aspects of the present disclosure may be applied to other suitable medical procedures.

[0090] The present disclosure provides a surgical illuminator that provides a deformative illumination structure that can be adapted for different surgical procedures, operation room setups, and surgeons. Referring to FIGS. 4A and 4B, an illuminator 100 constructed according to the present invention includes a connector or optical coupling section 102 that connects to a light source (e.g. light pipe or an optical fiber bundle) or power source. Illuminator 100 includes a holder section 104 that enables the clinician or surgeon to control the illuminator position and illumination direction. This holder 104 may be bent to hold and to position the illuminator for different surgical procedures, setups and likings of different surgeons. This holder could also include a clamp or attachment that allows the illuminator to be held in position though attaching to other equipment in the operation room (i.e. surgical bed).

[0091] The illumination system 100 includes a deformable illumination section 106 that delivers light to a larger area and wider illumination angle than the forward light emitting illuminators. The deformable section 106 can be configured in two ways to give the desired field of illumination and intensity of illumination in the field of interest. First, the sections 104 and 106 may be bent and shaped to a desired shape/configuration once the surgical field of interest has been established. Second, sections of the elongate section 106 may be masked or coated with a reflective coating to reflect light being emitted along the length of section 106 so that it is reflected back out the unmasked or uncoated sections along length of section 106. Sections 104 and 106 are made of the same material so light coupled from coupler 102 into section 104 is transmitted to section 106 out of which the light is emitted. Section 102 may be coated with a reflective material to prevent losses at the air/surface interface to ensure the most amount of light is transmitted to section 106 from the light source.

[0092] FIG. 5A shows an embodiment of the lighting system having a coating over the elongate section 106 so light is only emitted out the distal end of the elongate section to give forward planar illumination. FIG. 5B shows an embodiment of the lighting system which is uncoated all along the length of flexible section 106 to give large area

wide angle illumination, with the elongate light emitting section **106** shown nestled in the sulci **32** of a patient's brain.

[0093] This is more clearly seen in FIGS. **6A** to **6D** which shows several such embodiments. Specifically, embodiment **108** shown in FIG. **6A** has its elongate section **106** coated with a reflective coating on the outer surface thereof so all light is reflected back into the body of section **106** and emitted from the distal end **24** to give forward planar illumination.

[0094] FIG. **6B** shows an embodiment **140** showing only the elongate section **106** which is uncoated along its length so light is emitted all along its length and its distal end **24**.

[0095] Embodiment **142** in FIG. **6B** shows only the elongate section **106** which is coated along most of its length, but not all of it, so light is emitted at its distal end **24** and a short portion adjacent to the distal end **24**.

[0096] Embodiment **144** in FIG. **6B** shows only the elongate section **106** which is coated along most of its length but not totally circumferentially so that light is emitted from one side of elongate section **106** and the emitted at its distal end **24**.

[0097] Embodiment **146** in FIG. **6C**, left hand side, shows the elongate section **106** shaped into a circular shape so that a circular area is illuminated.

[0098] Embodiment **148** in FIG. **6C**, right hand side, shows the elongate section **106** shaped into a coil, for example it may be shaped to coil around a surgical tool to illuminate the region around the tool.

[0099] FIG. **6D** shows an embodiment **150** shows the a deformable illuminator having two elongate sections **152** and **154** shaped with each having their proximal ends connected to a coupler **156** which is shown coupled to a light source **158** (an example of a light source being the end of an optical fiber bundle). Elongate section **154** is uncoated so light is emitted all along its length, and elongate section **152** is coated all around its circumference so light is only emitted at its distal end **24**. Sections **152** and **154** may be shaped independently of each other as required.

[0100] FIGS. **7A** and **7B** illustrate several different non-limiting exemplary embodiments of integrating the lighting system with a surgical tool. In FIG. **7A**, only one illuminator **106**, such as one shown in FIG. **6B**, is integrated along the length of a tissue removal tool. In FIG. **7B**, an illuminator such as that shown in FIG. **6D**, has two elongate sections **152** and **154** attached to opposite sides of the tissue removal tool.

[0101] FIG. **8** illustrates an exemplary embodiment of integrating the coiled surgical lighting system **148** of FIG. **6C** with an access port **170** shown inserted into tissue **162**.

[0102] Referring to FIG. **9**, a feedback surgical lighting system shown generally at **200** includes a light source **202** in which its intensity and spectrum preferably are electrically controllable. For example, this could be achieved through the use of two electrically controlled motors (not shown). One motor can control the intensity of the output light through rotating a variable neutral density filter wheel or a variable aperture wheel (i.e. a wheel with different hole density in the tangential direction) set in the light path of the light source. The second motor can control the output light spectrum by rotating a spectrum adjuster set in the light path. One exemplary spectrum adjuster could be the one described in US20120236534 which for the purposes of the US is incorporated herein in its entirety. The spectrum adjuster includes a region of continuously-variable spectrum adjust-

ing material, usable for adjusting the spectrum of light passing through the spectrum adjuster. The variable spectrum adjusting material may be a color-attenuating material, such as a filtering material, or it may be a wavelength-shifting material, such as a phosphor. The output light spectrum is adjusted based upon the relative positioning of the light source **202** and the spectrum adjuster which can be electrically controlled through a motor once the spectrum adjuster is set on a suitable axis.

[0103] System **200** includes a computer processor **212** and a spectrometer **214** connected to processor **212** that analyzes the color spectrum of the reflected light. The discussion above with respect to the computer **302** and memory **304** applies equally to computer processor **212** in system **200**. The light source **202** is connected to the computer processor **212**. A flexible surgical illuminator **204** has a flexible and shapeable distal section **206** made out of a scattering material as discussed above and a proximal fiber coupling which includes sections **208** and **210** which form a typical bifurcated fiber light pipe or fiber bundle. Coupling section **208** is optically coupled to the light source **202** for transmitting light from light source **202** to the flexible shapeable section **206** and coupling section **210** is configured for coupling the light source **202** to spectrometer **214**.

[0104] System **200** includes a surgical camera **222** and a visual display **220** which are each connected to the computer processor **212**. Spectrometer **214** analyzes the color spectrum of the reflected light received from the tissue sample through the flexible and shapeable distal section **206** and the coupling section **210**.

[0105] Computer processor **212** is programmed to take the input color spectrum from the spectrometer **214** and correct the color at the display **220** through comparing the input color spectrum with a standard reference or a color profile set for different surgical procedures. This color profile is programmable as it is typically different for different types of surgery, such as brain surgery versus arthroscopic surgery.

[0106] FIG. **10** shows another embodiment shown generally at **240** which has a similar setup compared to system **200** of FIG. **9**. The difference is that system **240** shown in FIG. **10** does not have any communication between the processor **212** and the light source **202**. In the case of system **240**, the light source **202** does not need to have its intensity and spectrum electrically tunable. The intensity and color of the displayed image can be adjusted through color mapping in firmware or software stored in the processor **212**.

[0107] An advantage of system **200** is that it enables dynamic color correction and optimization so that the color correction and optimization can take into account the surrounding environment, tissue type and the illuminator type, position, number and configurations (i.e., the deformed shape of the illuminator). Another advantage of the system **200** is that it enables switching between illumination mode for different images, such as white light imaging, narrow band illumination and fluorescence imaging for different dyes, through using only part of the light source spectrum or multi-spectral imaging mode by scanning through part of the source spectrum or even the entire source spectrum. In an example for tumour removal, the user can first utilize white light imaging for the initial part of the surgery. This initial part of the surgery might include, but not limited to, opening the surgical site and creating an access path to the potential location of the tumor. Then, the clinician can inject dye to the surgical area for fluorescent imaging. The dye could also

be provided to the patient in other different ways including through drinking prior to the surgery.

[0108] Fluorescent imaging can be performed at the surgical area to identify the exact tumor location through switching the color profile at the processor **212** to that preset for fluorescent imaging for a particular dye. The fluorescent color profile then sets the illumination of the source from white light to one or multiple wavelengths or colors that match the excitation bands of the fluorescent dye. For example, for a fluorescent dye of PpIX, the light source may be configured to illuminate narrowband light at only 408, 510, 543, 583 and 633 nm which are the excitation peaks of PpIX. This eliminates the need for an excitation filter for fluorescent imaging. Further, light emission can be focused at wavelengths or colors that are most efficient in exciting the fluorescent dye or less distracted to the user. Similarly, narrow band imaging can be performed through a preset profile. In the narrow band illumination profile, a narrow band wavelength or color is outputted at the source to show contrast for a particular type of tissue such as blood vessels with NIR light. Similarly, multi-spectral imaging could be performed through a preset profile. In the multi-spectral imaging profile, a narrow band wavelengths or color of the light at the source output is swept and the camera records a series of images each captured with a different band of wavelength. Processor then gives a false color to each of the capture images in the series and displays the series of images through a false color map.

[0109] Referring to FIG. 11, Flow Chart 1 describes the general steps in using the feedback lighting system. First, in step 1 the user identifies the surgical area-of-interest in which illumination is required. Then, in step 2 the flexible and shapeable distal section **206** is shaped to provide the best illumination for the surgical field while maintaining the suitability of the surgical space for the surgeon to operate in. In step 3, the user selects a color profile that provides a suitable color scheme for the surgery being performed. Then, the illuminator is turned on in step 4 and, a reference sample is placed in front of the flexible and shapeable distal section **206** in step 5, where the light outputs, for color calibration. Light reflected from the reference sample is directed to the spectrometer **214** through coupling back into the flexible and shapeable distal section **206** and the coupling section **210**. The spectrometer **214** then outputs the reflected light intensity and color spectrum to the processor **212**. In step 6, at the processor **212**, the reflected light intensity and color spectrum is then compared to a standard reference or color profile to derive a set of calibration coefficients that are used to map the input intensity and color spectrum to the color profile. This coefficient is then used to adjust the light source intensity and color spectrum in step 7 to give the desired light intensity and color spectrum.

[0110] After calibration, the flexible and shapeable distal section **206** is positioned to illuminate the surgical field in steps 8 and 9. As the lighting condition changes during the surgical procedure, the intensity and spectrum of the light reflected into the spectrometer **214** changes. The processor **212** then utilizes the changes in the intensity and spectrum to adjust the color mapping coefficients. The color adjustment could be made based on different methods. In step 10, the processor is programmed to determine if the lighting conditions have changed by comparison of the current lighting condition with the desired light intensity and color spectrum programmed above, and if no change has occurred

and if in step 11 it is determined the procedure is finished the light source is turned off in step 12. Otherwise, if the lighting condition has changed as determined in step 10, and if the procedure still requires lighting then the illuminator is re-positioned as per step 8 and the procedure proceeds. Once the procedure is finished the illuminator is turned off in step 12.

[0111] One example method can be based on a predictive method that utilizes the intensity per color detected to determine the lighting condition in the surgical field. For each lighting condition, a predetermined color mapping can be used to provide the best lighting condition and tissue contrast based on the selected color profile. The coefficient is then relayed to the light source **202** to adjust the illumination output dynamically to improve the lighting condition at the surgical field. For example, if the surgical field contains many fine blood vessels, the intensity of the red color can be increased to show a greater contrast in the surgical image.

[0112] In another example, if the surgical field contains many strong reflecting surfaces such as bones, the overall intensity can be reduced to prevent saturation in the surgical camera. If fluorescent imaging is required, a certain color can be set to illuminate the surgical field while turning the intensity for all the other color to low or zero. The user can also switch the color profile for cases such as switching between fluorescence imaging and white light imaging) during the surgical procedure without needing to change the illuminator and its position. Referring to FIG. 12, Flow Chart 2 describes the method to use the feedback surgical system in this scenario. Flow Chart 2 is similar to Flow Chart 1 except that an illuminator mode can be selected in step 3 in which the user can select modes such as, but not limited to, white light illumination mode or fluorescent illumination mode for a particular dye. In addition, the user can switch between the different illumination modes at step 12 until no more illumination is required and the illuminator is turned off in step 13.

[0113] Deformability is an important aspect of this illumination system for surgical environments. This feature enables the illumination field to be shaped once a surgical region has been exposed to provide an irregular field of illumination as needed. Furthermore, this feature enables relative intensity control over the surgical field to focus light in multiple main areas while providing enough lighting in other areas for the surgeon to observe the field. This feature deformability may also be used with the optional feature of masking the section **106**, to provide illumination directionality and intensity control.

[0114] The illumination system may be coupled to a surgical tool, such as an access port or a resection tool, to allow the illumination to focus on or follow the field of interest in which the surgeon is operating on. In addition, the illuminator(s) can be brought closer to the field of interest compared to conventional illumination systems in which the illuminator is coupled to the camera on top of the surgical field or just held on top of the surgical field. This allows the illuminator(s) to illuminate the entire surgical field with higher brightness.

[0115] Other optical elements may be coupled to the elongate sections **106**. For example, micro-lenses, focusing optics or polarization-controlled optics (i.e. polarizers, quarter wave-plates) could be used in any combination to further focus or defocus the light to achieve different areas of

illumination, different shapes of the illumination field and different intensities of brightness or illumination. The careful design of these optical components can further be used to minimize other unwanted effects such as shadows from surgical tools.

[0116] In addition, wavelength filters may be added and positioned in front of the light emitted from the illuminator to provide wavelength selected illumination for a large field area with an unconventional field shape. This could be particularly useful for fluorescence imaging, multispectral imaging and hyperspectral imaging to focus the excitation light on a larger illumination field.

[0117] Exemplary materials that may be used to produce the flexible, shape-able and deformable surgical lighting system disclosed herein are disclosed in U.S. Pat. No. 5,744,534 issued Apr. 28, 1998, which is incorporated herein in its entirety by reference. U.S. Pat. No. 6,591,049 describes other potential materials and method or producing light emitting materials, which is incorporated herein in its entirety by reference.

[0118] The materials used to make the flexible, shape-able and deformable surgical lighting are made by mixing and dispersing a transparent material in a transparent elastomer matrix having a glass transition temperature that is lower or substantially equal to room temperature, with the transparent material selected to have an index of refraction different from a refractive index of the matrix.

[0119] The light scattering material is prepared by mixing with and dispersing in a transparent elastomer matrix material particles of a transparent material of a different refractive index than the matrix material.

[0120] In an embodiment this may be achieved by mixing with and dispersing the transparent material in a monomer which is polymerized to form the transparent elastomer having the glass transition temperature lower than or equal to room temperature.

[0121] In another embodiment the material may be made by mixing a monomer into a transparent elastomer matrix having the glass transition temperature lower than or equal to room temperature and then inducing polymerization of the monomer into a polymer to produce the transparent material having a different index of refraction from the transparent elastomer.

[0122] In another embodiment the light scattering material may be prepared by polymerizing at least two distinct monomers which have different reactivity and which when polymerized form transparent polymers having different indexes of refraction. One of the monomers upon polymerizing forms an elastomer matrix having the glass transition temperature of lower than or equal to room temperature.

[0123] The resulting light scattering material has an optically inhomogeneous sea-island structure (the matrix forming the sea and the transparent particles the islands), so that light entering the light scattering material is scattered at the interface between the transparent material islands having different indexes of refraction due to refraction and reflection of light without a substantial loss by absorption because the light scattering material is entirely formed of the transparent materials. The incident light is efficiently scattered out of the material. Since the light scattering material is mainly formed of the elastomer matrix having a glass transition temperature of lower than room temperature, it is fully flexible and easy to handle and process at room temperature.

[0124] The term particles, as it refers to the transparent materials forming the islands the matrix sea, means transparent materials that may have spherical, ellipsoidal, rod, plate and or any other desired shape.

[0125] The transparent elastomer matrix may be selected from the group consisting of an acrylate ester polymer and an acrylate ester copolymer. The acrylate ester copolymer may comprise an acrylate ester monomer and a monomer selected from the group consisting of a methacrylate ester, styrene, alpha-methyl styrene, vinyl acetate, methyl vinyl ketone, phenyl vinyl ketone and vinyl benzoate monomer. The acrylate ester polymer, the acrylate ester monomer and the methacrylate ester contain a substituent selected from the group consisting of a methyl, ethyl, butyl, propyl, stearyl, lauryl, 2-ethylhexyl, cyclohexyl, tetrahydrofurfuryl, amino-ethyl, 2-hydroxyethyl, 3-hydroxypropyl, 3-chloro-2-hydroxypropyl, and trifluoroethyl radical.

[0126] The particles of transparent material may comprise an inorganic material selected from the group consisting of quartz glass, multicomponent glass, sapphire and quartz.

[0127] Alternatively, the particles of transparent material may comprise an organic material selected from the group consisting of polyamides, polystyrene, polymethyl methacrylate, polycarbonate, polyvinyl chloride, polyvinylidene chloride, polyvinyl acetate, polyethylenevinyl acetate copolymers, polyvinyl alcohol, polyethylenepolyvinyl alcohol copolymers, fluoride resin, silicone resin, polyisoprene rubber, polybutadiene rubber, a styrene-butadiene copolymer, butyl rubber, halogenated butyl rubber, chloroprene rubber, acrylic rubber, EPDM, an acrylonitrile-butadiene copolymer, fluoride rubber, silicone rubber, acrylonitrile-butadiene-styrene resin, acrylonitrile-styrene copolymer resin, a styrene-butadiene copolymer, an acrylonitrile-EPDM-styrene terpolymer, a styrene-methyl methacrylate copolymer, methacrylic resin, epoxy resin, polymethyl pentene, allyl diglycol carbonate resin, spirane resin, amorphous polyolefin, polyallylate, polysulfone, polyallyl sulfone polyether sulfone, polyether imide, polyimide, polyethylene terephthalate, diallyl phthalate, polyester carbonate, paraffin, polybutene, and polyisobutylene.

[0128] The difference in index of refraction between the transparent elastomer matrix and the particles of the transparent material is at least 0.03, wherein the particles of the transparent material have a size greater than the wavelength of incident light by a factor of about 2 to about 10, the amount of the transparent material particles blended is about 0.01 to about 10 parts by weight per 100 parts by weight of the transparent elastomer matrix.

[0129] Details on how to make the deformable and shape-able materials are disclosed in U.S. Pat. No. 5,744,534, which for the purposes of the United States patent application claiming priority from the present application, is incorporated by reference.

[0130] The specific embodiments described above have been shown by way of example, and it should be understood that these embodiments may be susceptible to various modifications and alternative forms. It should be further understood that the claims are not intended to be limited to the particular forms disclosed, but rather to cover all modifications, equivalents, and alternatives falling within the spirit and scope of this disclosure.

1. A non-rigid, bendable surgical lighting system, comprising:

- a) one or more elongate light emitting members comprised of a non-crosslinked transparent elastomer matrix material having a glass transition temperature of lower than or substantially equal to room temperature to render said at least one elongate light emitting member bendable and shape-able, particles of a transparent material having a refractive index different from a refractive index of the matrix material dispersed in said elastomer matrix material so that light coupled into said at least one elongate light emitting member is scattered and refracted out of the elongate light emitting member along a preselected length;
- b) a proximal end of said one or more elongate light emitting members configured to be coupled to a light source; and
- c) wherein a length of said one or more elongate light emitting members being chosen sufficiently long so that in operation, a medical clinician, having established and exposed an anatomical surgical site, bends and shapes said at least one elongate light emitting member to provide a desired level of lighting of the anatomical surgical site while accommodating surgical instruments present in the anatomical surgical site.
2. The lighting system according to claim 1, wherein one or more preselected sections of said at least one elongate light emitting member are coated with a coating to prevent light being emitted from said one or more preselected sections.
3. The lighting system according to claim 1, wherein said at least one elongate light emitting member is two or more elongate light emitting members each having one end configured to be optically coupled to a light source.
4. The lighting system according to claim 1, wherein said transparent elastomer matrix is selected from the group consisting of an acrylate ester polymer and an acrylate ester copolymer;
- wherein said acrylate ester copolymer comprises an acrylate ester monomer and a monomer selected from the group consisting of a methacrylate ester, styrene, alpha-methyl styrene, vinyl acetate, methyl vinyl ketone, phenyl vinyl ketone and vinyl benzoate monomer; and wherein said acrylate ester polymer, said acrylate ester monomer and said methacrylate ester contain a substituent selected from the group consisting of a methyl, ethyl, butyl, propyl, stearyl, lauryl, 2-ethylhexyl, cyclohexyl, tetrahydrofurfuryl, aminoethyl, 2-hydroxyethyl, 3-hydroxypropyl, 3-chloro-2-hydroxypropyl, and trifluoroethyl radical.
5. The light scattering material of claim 1, wherein the particles of said transparent material comprise an inorganic material selected from the group consisting of quartz glass, multicomponent glass, sapphire and quartz.
6. The lighting system according to claim 1, wherein the difference in index of refraction between the transparent elastomer matrix and the particles of the transparent material is at least 0.03, wherein the particles of the transparent material have a size greater than the wavelength of incident light by a factor of about 2 to about 10, the amount of the transparent material particles blended is about 0.01 to about 10 parts by weight per 100 parts by weight of the transparent elastomer matrix.
7. The light scattering material of claim 1, wherein the particles of said transparent material comprise an organic material selected from the group consisting of polyamides,

polystyrene, polymethyl methacrylate, polycarbonate, polyvinyl chloride, polyvinylidene chloride, polyvinyl acetate, polyethylenevinyl acetate copolymers, polyvinyl alcohol, polyethylenevinyl alcohol copolymers, fluoride resin, silicone resin, polyisoprene rubber, polybutadiene rubber, a styrene-butadiene copolymer, butyl rubber, halogenated butyl rubber, chloroprene rubber, acrylic rubber, EPDM, an acrylonitrile-butadiene copolymer, fluoride rubber, silicone rubber, acrylonitrile-butadiene-styrene resin, acrylonitrile-styrene copolymer resin, a styrene-butadiene copolymer, an acrylonitrile-EPDM-styrene terpolymer, a styrene-methyl methacrylate copolymer, methacrylic resin, epoxy resin, polymethyl pentene, allyl diglycol carbonate resin, spirane resin, amorphous polyolefin, polyallylate, polysulfone, polyallyl sulfone polyether sulfone, polyether imide, polyimide, polyethylene terephthalate, diallyl phthalate, polyester carbonate, paraffin, polybutene, and polyisobutylene.

8. The lighting system according to claim 1, wherein said lighting system is a conductor-less, MRI compatible lighting system.

9. A flexible, adaptive surgical lighting system, comprising:

- a) non-rigid, bendable surgical lighting system including one or more elongate light emitting members;
- b) a light source, a proximal end of said one or more elongate light emitting members configured to be coupled to said light source;
- c) a spectrometer, a computer processor connected to said spectrometer, said light source connected to said spectrometer, a camera connected to said computer processor, a visual display connected to said computer processor;
- d) said spectrometer being configured to receive light reflected from an anatomical surgical site;
- e) said computer processor being programmed with instructions for
- i) receiving a reflected light intensity and color spectrum of the reflected light from the spectrometer, displaying it and to comparing it to a pre-selected color profile standard, and, based on differences between said reflected light intensity and color spectrum and said pre-selected color profile standard, adaptively adjust the light intensity and color spectrum of the displayed image; and
- ii) visually displaying the adjusted light intensity and color spectrum of the light received from the anatomical surgical site.

10. The flexible, adaptive surgical lighting system according to claim 9 wherein said computer processor is programmed to adaptively adjust intensity and color of the displayed image using firmware or software stored on said computer processor.

11. The flexible, adaptive surgical lighting system according to claim 9 wherein said light source has a controllable spectrum and intensity, and wherein said light source is connected to said computer processor, and wherein said computer processor is programmed to adaptively adjust intensity and color of the displayed image by adaptively adjusting the intensity and color of the light emitted by the light source.

12. The flexible, adaptive surgical lighting system according to claim 9, further comprising an illumination mode selection feature for switching between different modes of illumination.

13. The flexible, adaptive surgical lighting system according to claim **12** wherein said illumination mode includes a white light illumination mode, narrow band illumination mode, fluorescent illumination mode for a selected particular dye and multi-spectral imaging mode.

14. A method of controlling illumination of a surgical site, comprising:

- a) shaping a distal end of a flexible and bendable surgical lighting member which includes one or more elongate light emitting and collecting members;
- b) connecting a light source to a proximal end of said one or more elongate light emitting members, optically coupling a spectrometer to said light source, connecting a computer processor to said spectrometer, connecting a camera to said computer processor and connecting a visual display to said computer processor;
- c) directing light emitted from said one or more elongate light emitting and collecting members to a surgical site and collecting light reflected from said surgical site by said one or more elongate light emitting and collecting members and directing the collected reflected light into said spectrometer;
- d) directing a reflected light intensity and color spectrum of the reflected light from the spectrometer to the microprocessor and displaying it and comparing it to a pre-selected color profile standard, and, based on differences between said reflected light intensity and color

spectrum and said pre-selected color profile standard, adaptively adjusting the light intensity and color spectrum of the displayed image; and

- e) visually displaying the adjusted light intensity and color spectrum of the light received from the anatomical surgical site.

15. The method according to claim **14** wherein the intensity and color of the displayed image is adaptively adjusted using firmware or software stored on said computer processor.

16. The method according to claim **14** wherein said light source has a controllable spectrum and intensity, and including connecting said light source to said computer processor, and wherein said computer processor is programmed to adaptively adjust intensity and color of the displayed image by adaptively adjusting the intensity and color of the light emitted by the light source.

17. The method according to claim **14**, further comprising an illumination mode switching between different modes of illumination.

18. The method according to claim **17** wherein the step of switching between illumination mode includes switching between a white light illumination mode, a narrow band illumination mode, fluorescent illumination mode for a selected particular dye and a multi-spectral imaging mode.

* * * * *

专利名称(译)	可变形且可成形的手术照明装置和系统		
公开(公告)号	US20170086938A1	公开(公告)日	2017-03-30
申请号	US14/899254	申请日	2015-03-27
[标]申请(专利权)人(译)	聖納普醫療巴巴多斯公司		
申请(专利权)人(译)	SYNAPTIVE MEDICAL (巴巴多斯) INC.		
当前申请(专利权)人(译)	SYNAPTIVE MEDICAL (巴巴多斯) INC.		
[标]发明人	MAK SIU WAI JACKY WOOD MICHAEL FRANK GUNTER		
发明人	MAK, SIU WAI JACKY WOOD, MICHAEL FRANK GUNTER		
IPC分类号	A61B90/30 A61B5/00 A61B1/06		
CPC分类号	A61B90/30 A61B1/0638 A61B2090/306 A61B5/0075 A61B5/0084 A61B5/0071		
外部链接	Espacenet USPTO		

摘要(译)

本公开提供了一种用于外科手术应用的无导体，可成形手术照明系统，其中医疗临床医生一旦建立了手术部位，就可以使照明系统成形以选择性地照射所需体积的手术部位。该系统包括一个或多个预选长度的细长发光构件，该细长发光构件由透明弹性体基质材料形成，其具有低于或基本上等于室温的玻璃化转变温度，以使细长发光构件可弯曲和可成形。嵌入透明弹性体基质材料中的是透明材料的颗粒，其折射率不同于分散在弹性体基质材料中的基质材料的折射率，使得耦合到细长发光构件中的光被散射并折射出细长的发光构件。发光元件沿其长度方向。细长发光构件的一端构造造成联接到光源。

