



US009463318B2

(12) **United States Patent**
Mashiach et al.

(10) **Patent No.:** **US 9,463,318 B2**
(45) **Date of Patent:** **Oct. 11, 2016**

(54) **TREATMENT OF SLEEP APNEA VIA BILATERAL STIMULATION**

I/3787 (2013.01); *A61N 1/37223* (2013.01);
A61N 1/37229 (2013.01); *A61N 2/006*
(2013.01); *A61B 5/4519* (2013.01); *A61B*
5/6822 (2013.01); *A61B 5/6833* (2013.01);
A61B 5/6876 (2013.01); *A61B 2560/0219*
(2013.01); *A61B 2562/164* (2013.01);
(Continued)

(71) Applicants: **Adi Mashiach**, Tel Aviv (IL); **Itzik Mashiach**, Tel Aviv (IL)

(72) Inventors: **Adi Mashiach**, Tel Aviv (IL); **Itzik Mashiach**, Tel Aviv (IL)

(73) Assignee: **NYXOAH SA.**, Mont-St-Guibert (BE)

(*) Notice: Subject to any disclaimer, the term of this patent is extended or adjusted under 35 U.S.C. 154(b) by 0 days.

(58) **Field of Classification Search**

CPC *A61N 1/36078*; *A61N 1/36128*;
A61N 1/36189; *A61N 1/36003*; *A61N*
1/37229; *A61N 1/3756*; *A61N 1/3787*
USPC 607/48, 60, 134, 152, 118
See application file for complete search history.

(21) Appl. No.: **14/307,040**

(22) Filed: **Jun. 17, 2014**

(65) **Prior Publication Data**

US 2014/0379049 A1 Dec. 25, 2014

Related U.S. Application Data

(63) Continuation-in-part of application No. 14/041,598, filed on Sep. 30, 2013, which is a continuation-in-part of application No. 13/629,690, filed on Sep. 28, 2012, said application No. 14/041,598 is a continuation-in-part of application No. 13/629,694, filed on Sep. 28, 2012, now Pat. No. 8,577,472, and a continuation-in-part of application No. 13/629,701,

(Continued)

(56) **References Cited**

U.S. PATENT DOCUMENTS

7,447,551 B2* 11/2008 Kuo *A61N 1/3756*
607/116
7,809,442 B2* 10/2010 Bolea *A61N 1/0556*
607/118

(Continued)

Primary Examiner — Christopher D Koharski

Assistant Examiner — Michael Carey

(74) *Attorney, Agent, or Firm* — Finnegan, Henderson, Farabow, Garrett & Dunner LLP

(51) **Int. Cl.**

A61N 1/05 (2006.01)

A61N 1/36 (2006.01)

(Continued)

(52) **U.S. Cl.**

CPC *A61N 1/36003* (2013.01); *A61B 5/0031*
(2013.01); *A61B 5/11* (2013.01); *A61B 5/113*
(2013.01); *A61B 5/4818* (2013.01); *A61B*
5/682 (2013.01); *A61F 5/566* (2013.01); *A61N*
1/0514 (2013.01); *A61N 1/0526* (2013.01);
A61N 1/0553 (2013.01); *A61N 1/3601*
(2013.01); *A61N 1/3606* (2013.01); *A61N*
1/3611 (2013.01); *A61N 1/36057* (2013.01);
A61N 1/36135 (2013.01); *A61N 1/36146*
(2013.01); *A61N 1/3756* (2013.01); *A61N*

(57) **ABSTRACT**

A neuromodulation device is provided. The neuromodulation device may include a carrier configured for implantation in a subject, the carrier including a first elongated arm and a second elongated arm, each extending from a central portion of the carrier. The device may further include a first pair of modulation electrodes arranged on the first elongated arm, a second pair of modulation electrodes arranged on the second elongated arm. The carrier may be sized and shaped for implantation in a vicinity of a hypoglossal nerve to be modulated such that the first pair of modulation electrodes is located to modulate a first hypoglossal nerve on a first side of the subject and the second pair of modulation electrodes is located to modulate a second hypoglossal nerve on a second side of the subject.

8 Claims, 25 Drawing Sheets

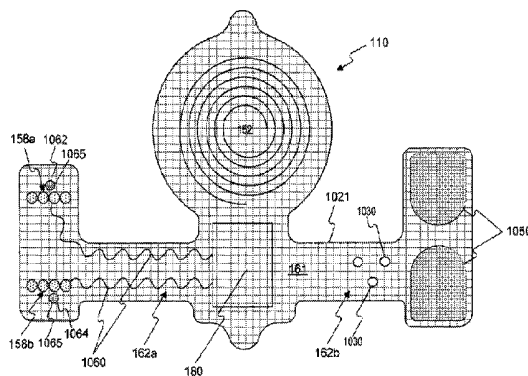

Related U.S. Application Data

filed on Sep. 28, 2012, now Pat. No. 8,588,941, and a continuation-in-part of application No. 13/629,712, filed on Sep. 28, 2012, now Pat. No. 9,314,613, and a continuation-in-part of application No. 13/629,730, filed on Sep. 28, 2012, now Pat. No. 8,577,465, and a continuation-in-part of application No. 13/629,741, filed on Sep. 28, 2012, now Pat. No. 8,577,466, and a continuation-in-part of application No. 13/629,748, filed on Sep. 28, 2012, now Pat. No. 8,700,183, and a continuation-in-part of application No. 13/629,757, filed on Sep. 28, 2012, now Pat. No. 9,302,093, and a continuation-in-part of application No. 13/630,392, filed on Sep. 28, 2012, now Pat. No. 8,644,957, and a continuation-in-part of application No. 13/629,762, filed on Sep. 28, 2012, now Pat. No. 8,577,467, and a continuation-in-part of application No. 13/629,793, filed on Sep. 28, 2012, now Pat. No. 8,577,468, and a continuation-in-part of application No. 13/629,819, filed on Sep. 28, 2012, now Pat. No. 8,718,776, and a continuation-in-part of application No. 13/629,686, filed on Sep. 28, 2012, now Pat. No. 8,577,464, and a continuation-in-part of application No. 12/642,866, filed on Dec. 21, 2009, now Pat. No. 8,585,617, which is a continuation-in-part of application No. 12/581,907, filed on Oct. 20, 2009, said application No. 14/041,598 is a continuation-in-part of application No. 13/629,721, filed on Sep. 28, 2012, now Pat. No. 8,574,164, and a continuation-in-part of application No. 12/642,866, filed on Dec. 21, 2009, now Pat. No. 8,585,617, and a continuation-in-part of application No. 12/581,907, filed on Oct. 20, 2009, said application No. 14/041,598 is a continuation-in-part of application No. 13/629,725, filed on Sep. 28, 2012, now Pat. No. 8,577,478.

(60) Provisional application No. 61/541,651, filed on Sep. 30, 2011, provisional application No. 61/657,424, filed on Jun. 8, 2012, provisional application No. 61/836,089, filed on Jun. 17, 2013.

(51) **Int. Cl.**

<i>A61N 1/372</i>	(2006.01)
<i>A61N 1/375</i>	(2006.01)
<i>A61N 1/378</i>	(2006.01)
<i>A61N 2/00</i>	(2006.01)
<i>A61B 5/11</i>	(2006.01)
<i>A61B 5/113</i>	(2006.01)
<i>A61F 5/56</i>	(2006.01)
<i>A61B 5/00</i>	(2006.01)
<i>A61N 2/02</i>	(2006.01)

(52) **U.S. Cl.**

CPC *A61N 1/36075* (2013.01); *A61N 1/36117* (2013.01); *A61N 2/02* (2013.01)

(56)

References Cited

U.S. PATENT DOCUMENTS

8,577,465 B2 *	11/2013	Mashiach	A61N 1/0551 607/42
8,577,478 B2 *	11/2013	Mashiach	A61N 1/0551 607/134
2008/0109046 A1 *	5/2008	Lima	A61N 1/0551 607/42
2010/0063568 A1 *	3/2010	Staunton	A61N 1/0551 607/116

* cited by examiner

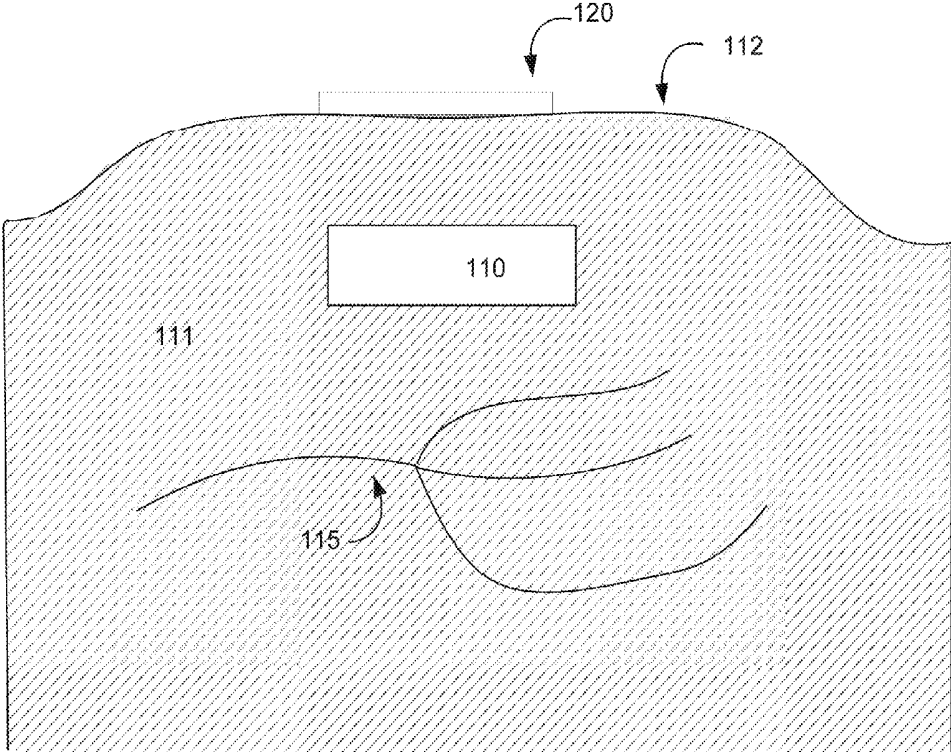

FIG. 1

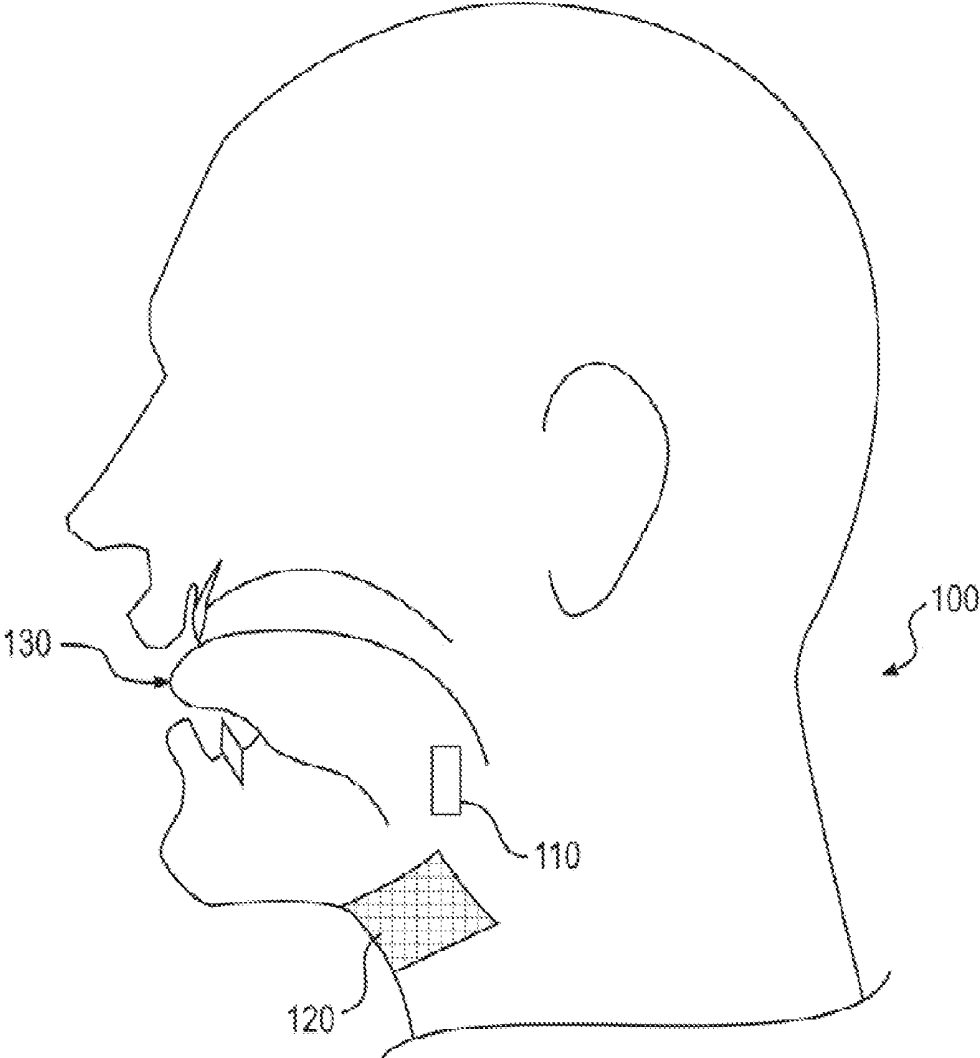

Fig. 2

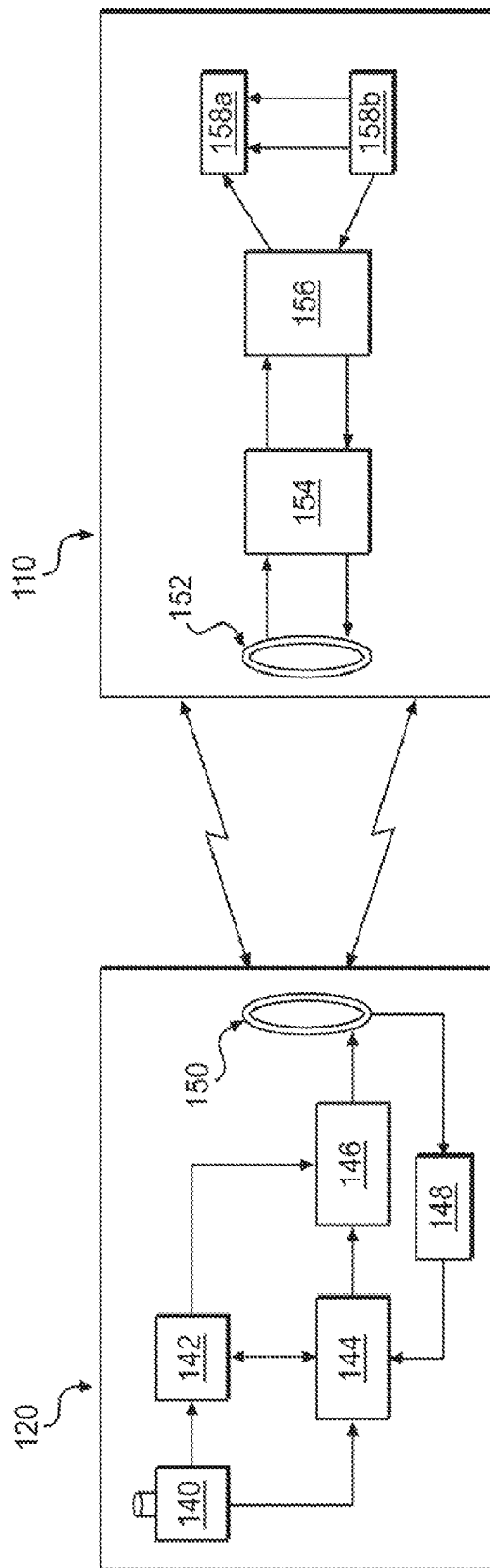

Fig. 3

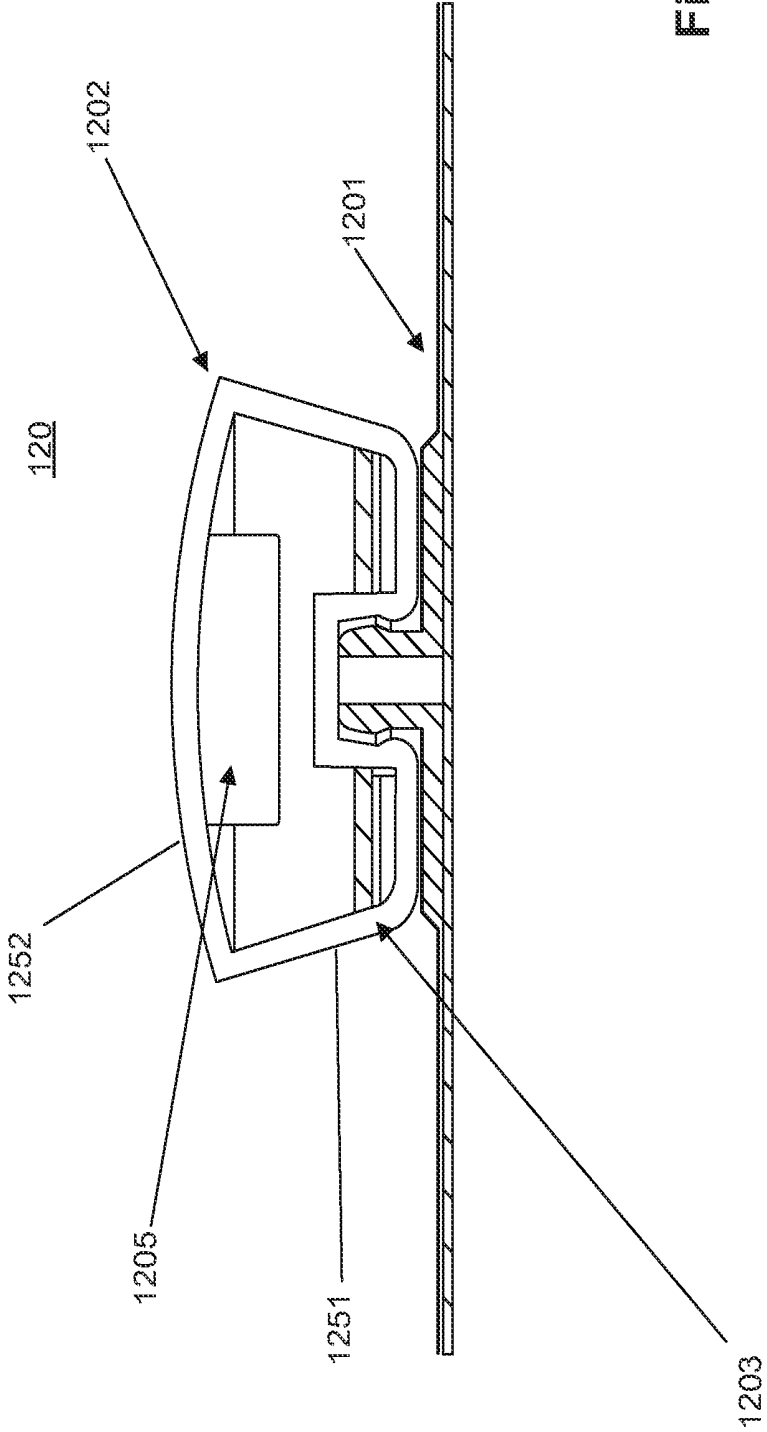

Fig. 4a

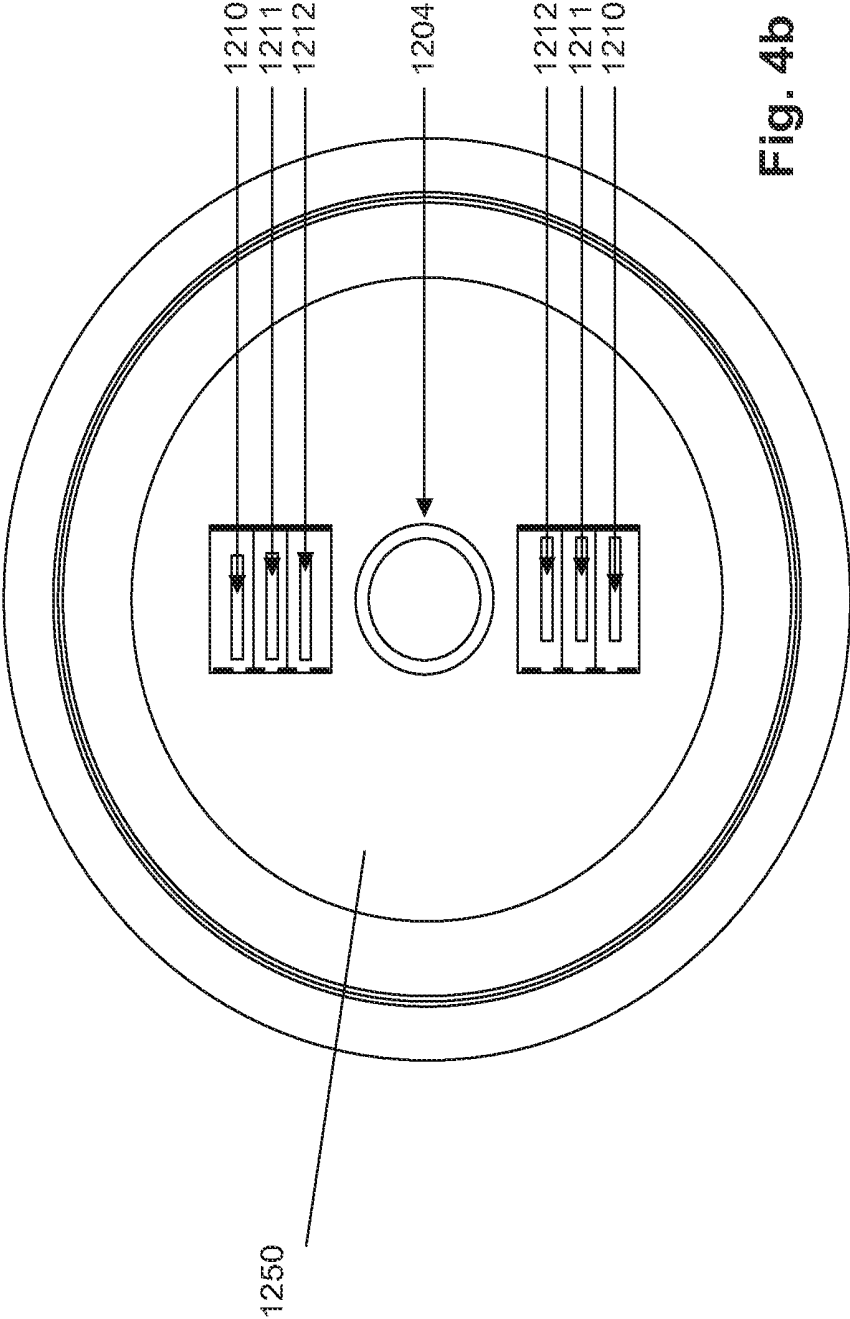

Fig. 4b

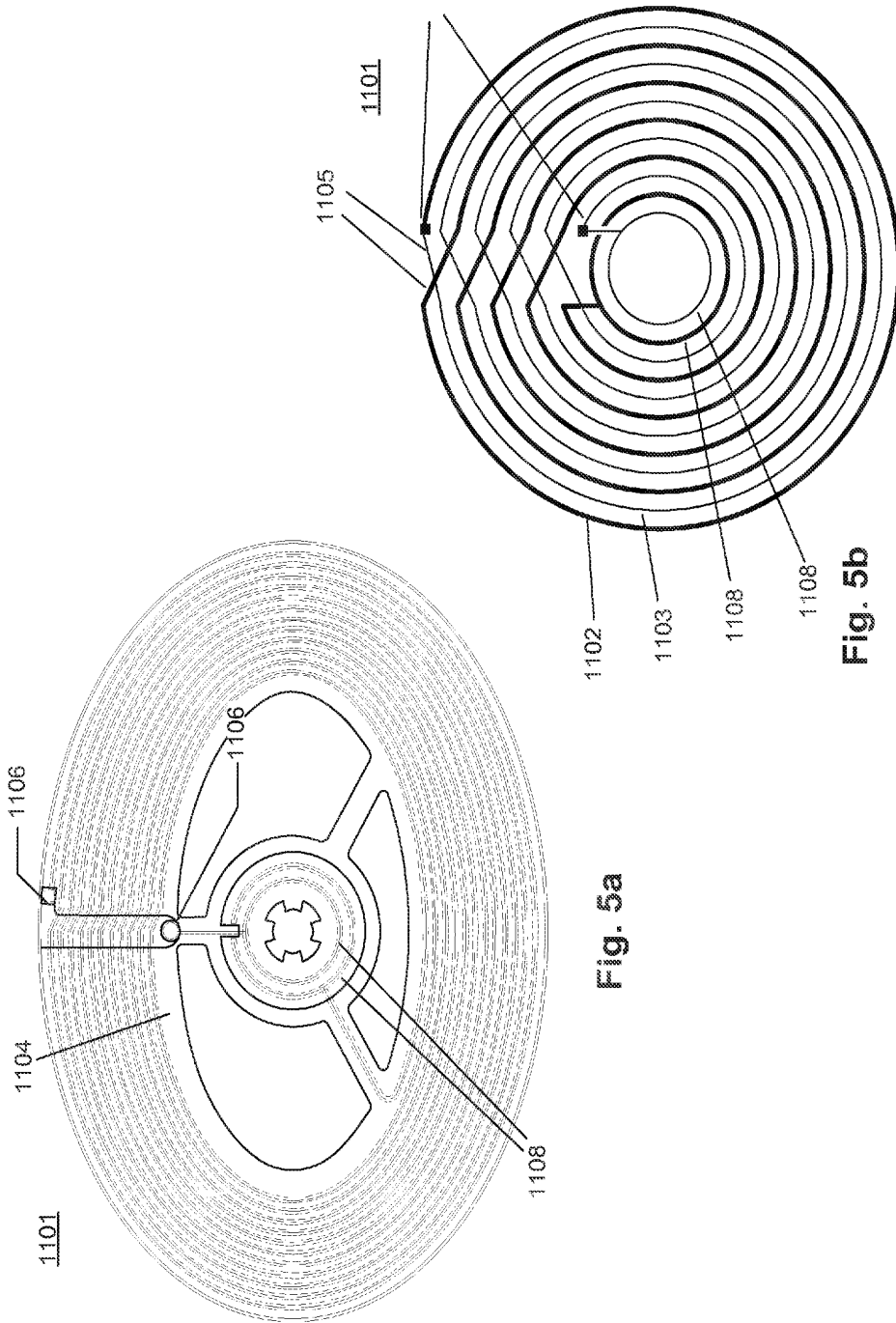

Fig. 5a

Fig. 5b

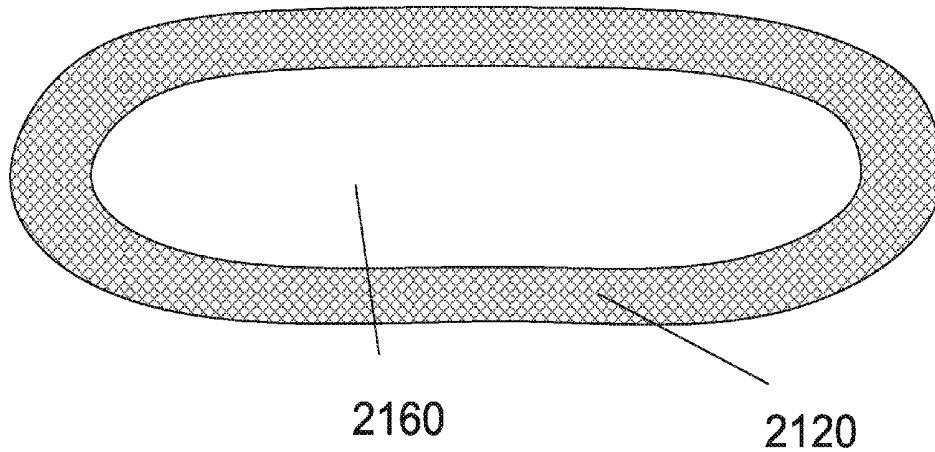

Fig. 6a

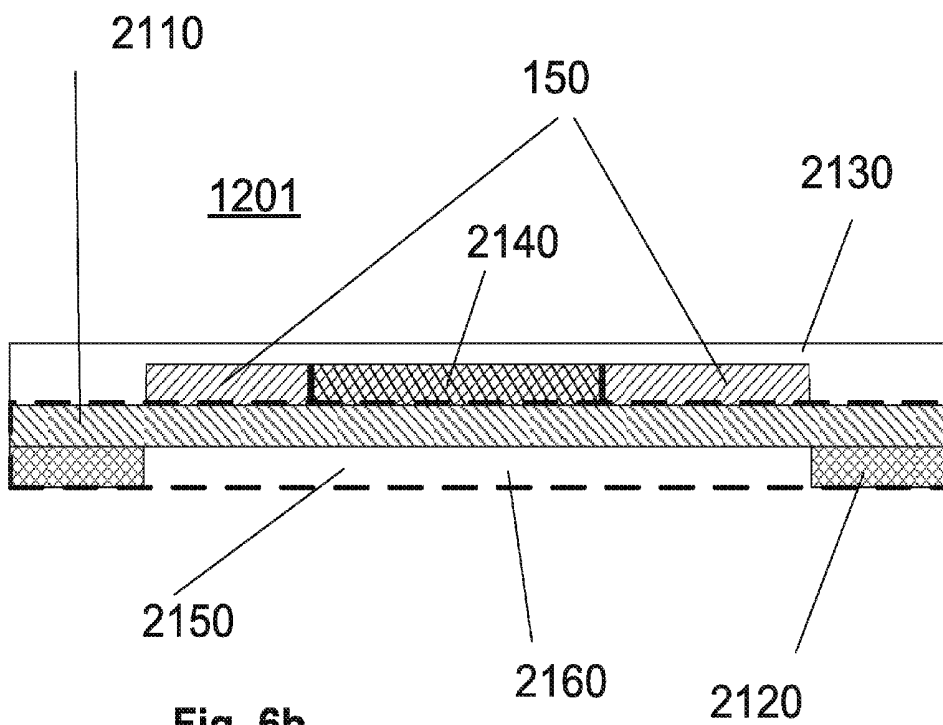

Fig. 6b

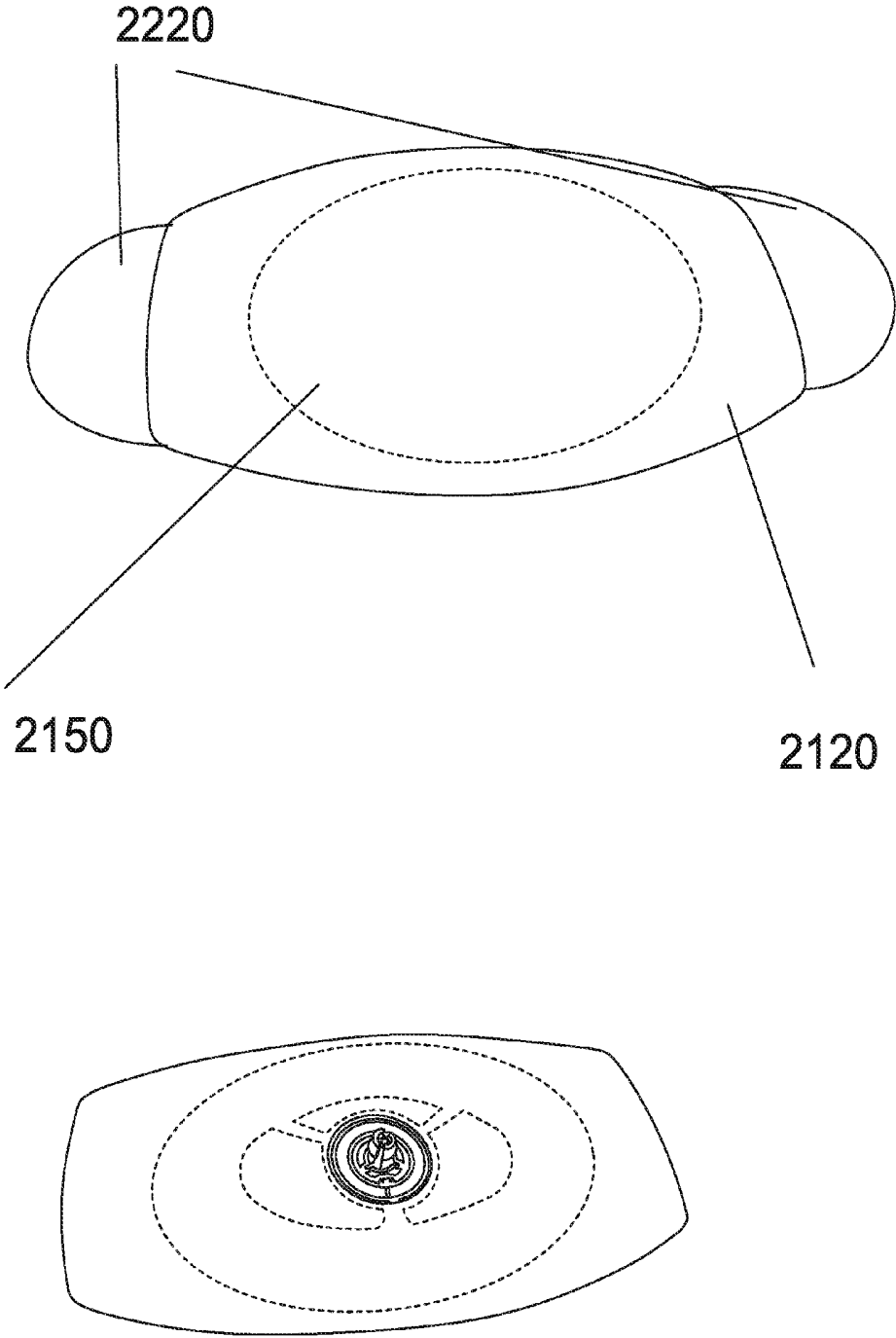
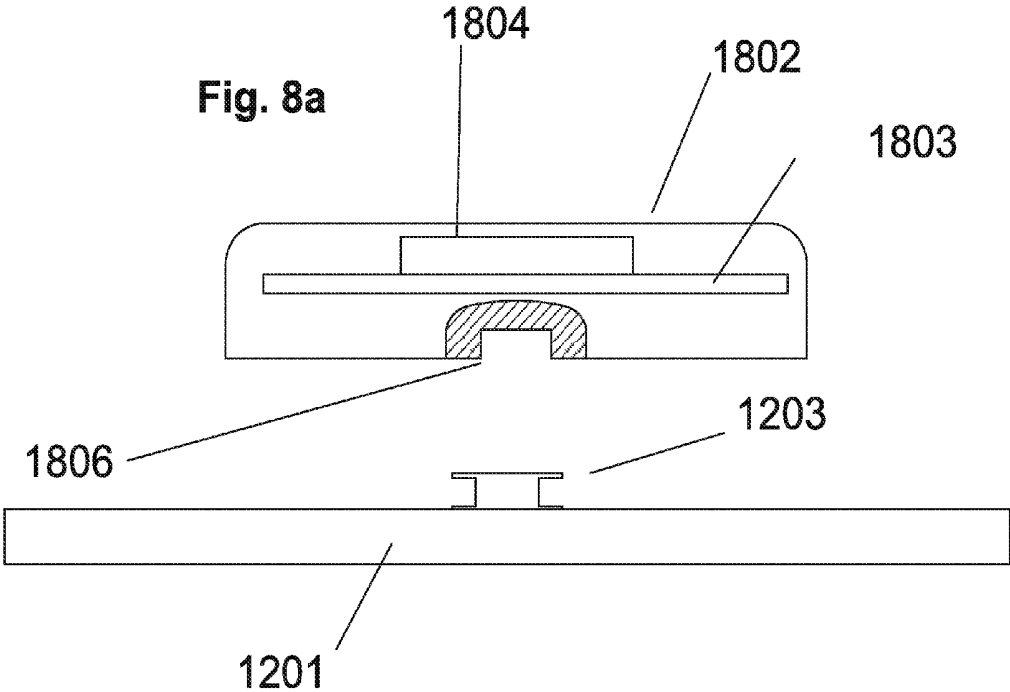
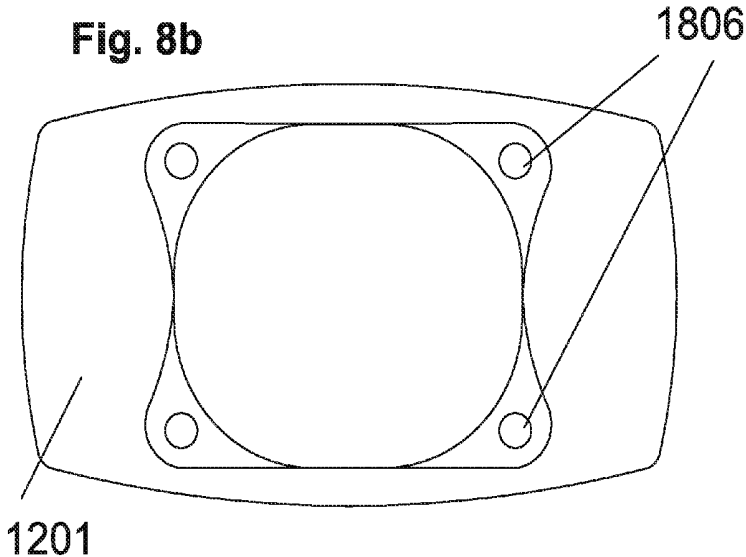
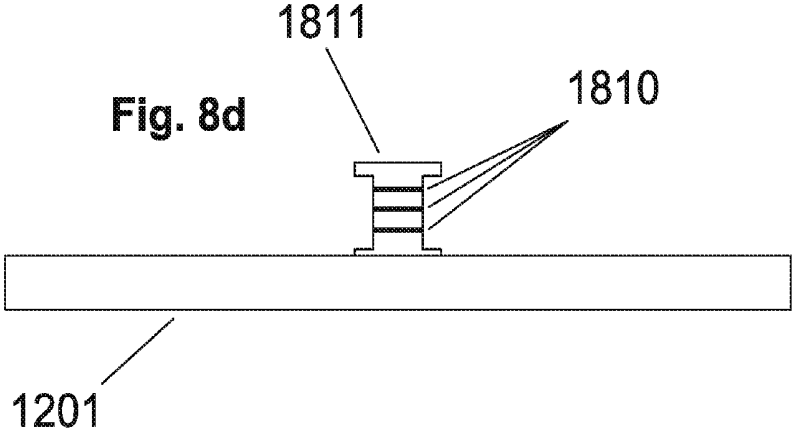
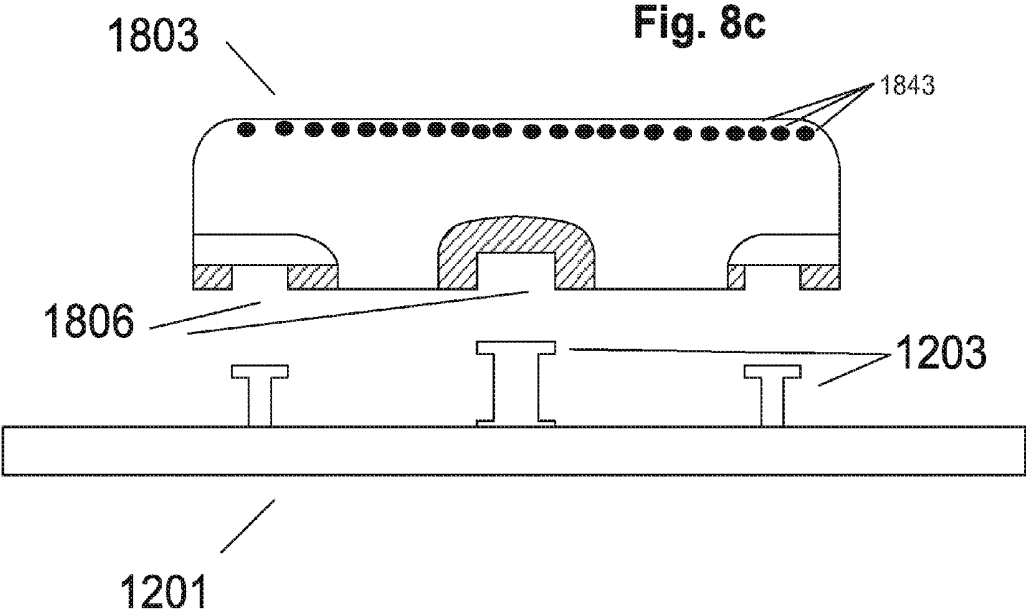

Fig. 7





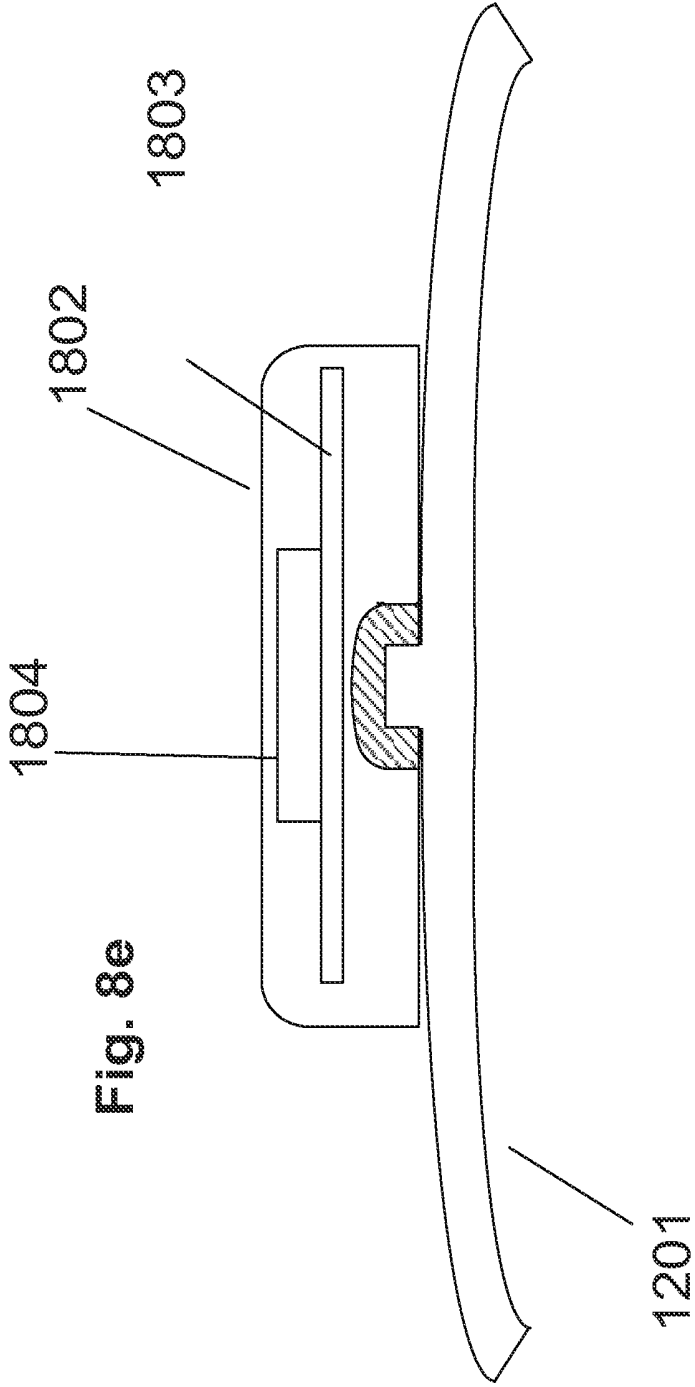

Fig. 8e

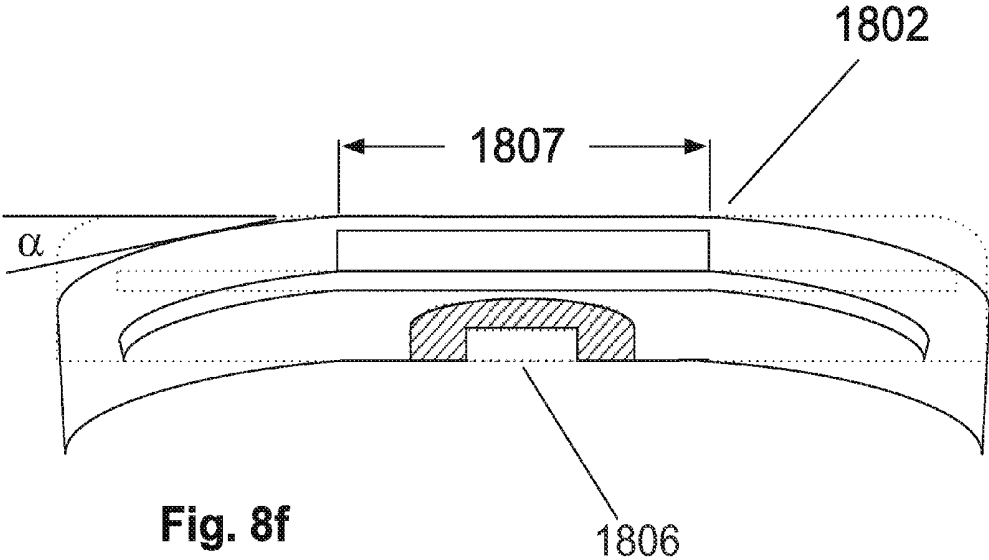

Fig. 8f

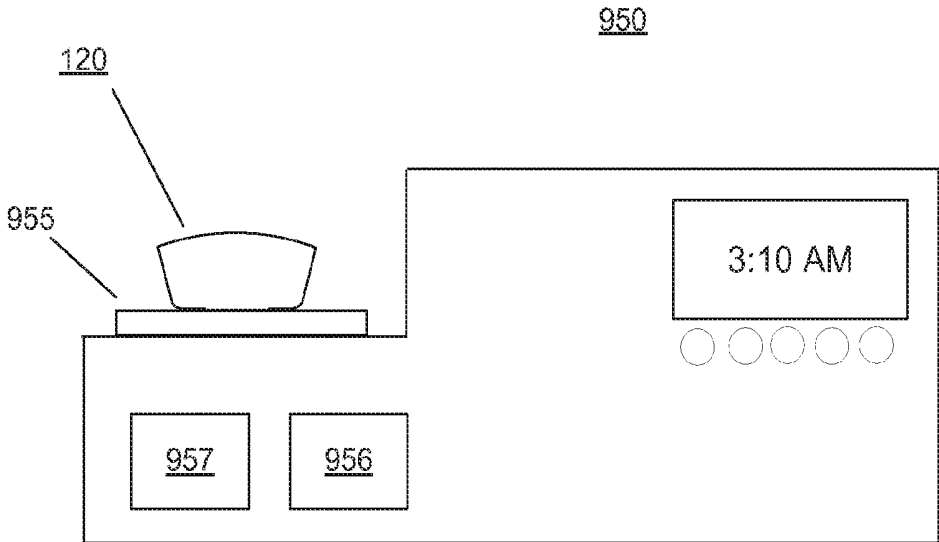

Fig. 9

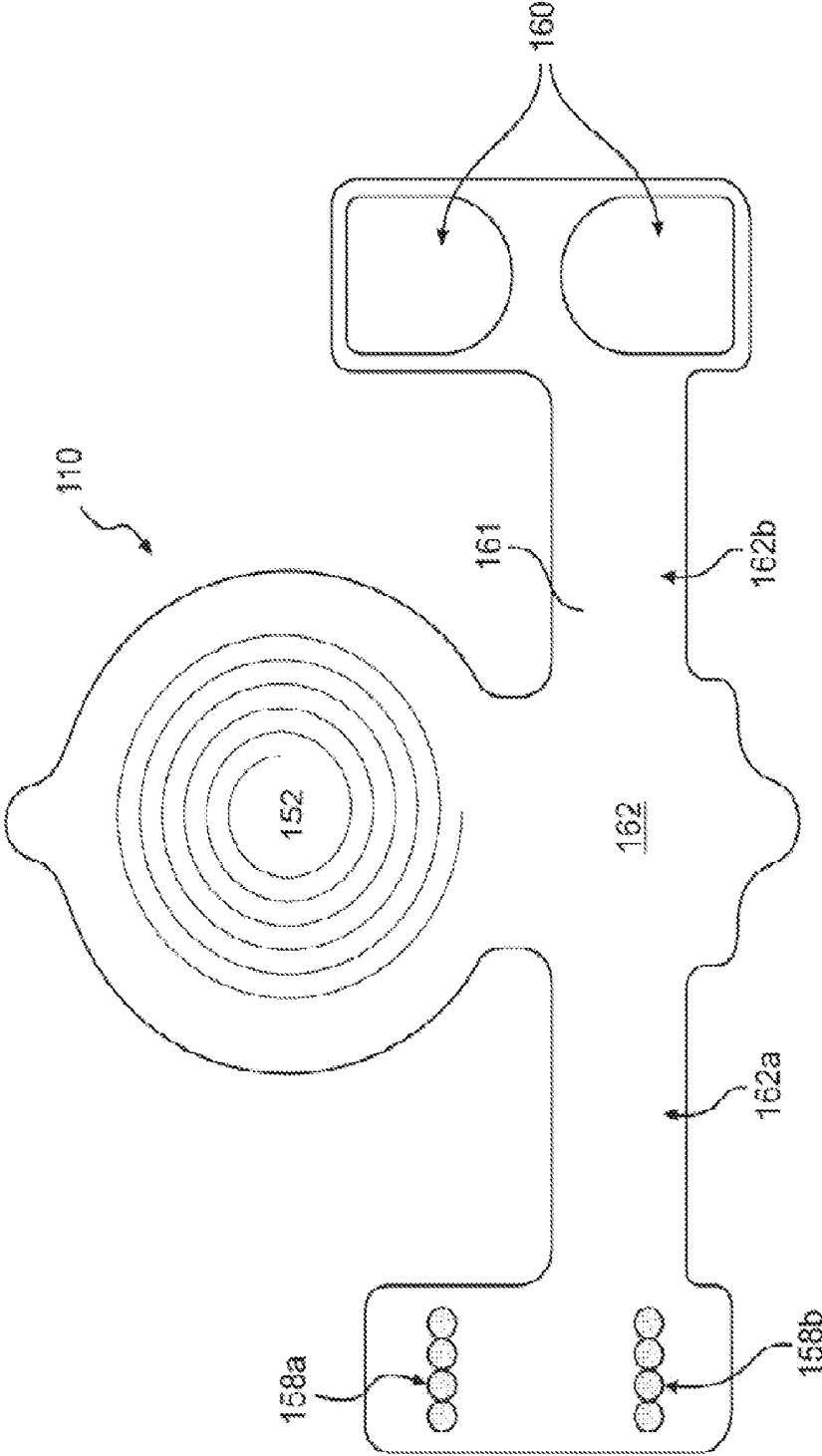

Fig. 10

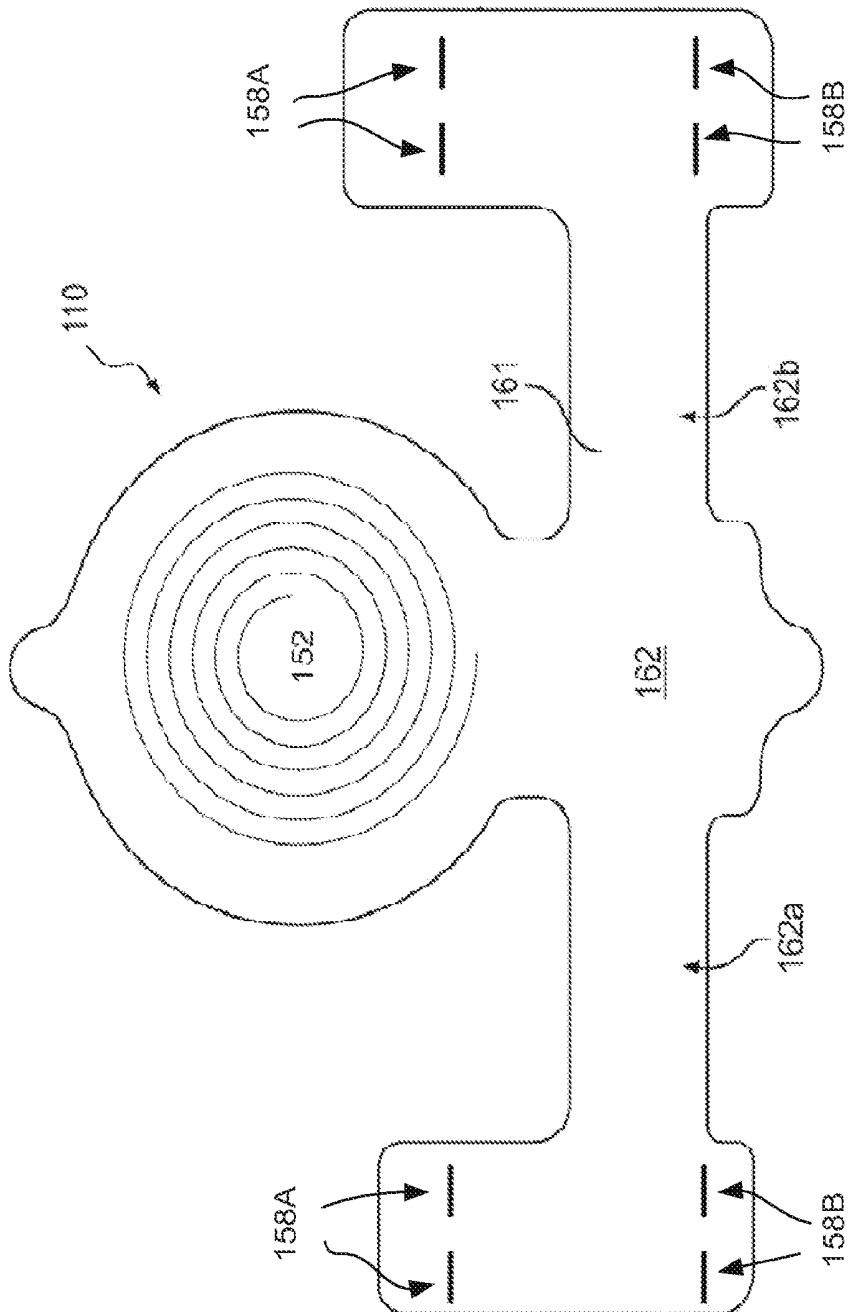

Fig. 11a

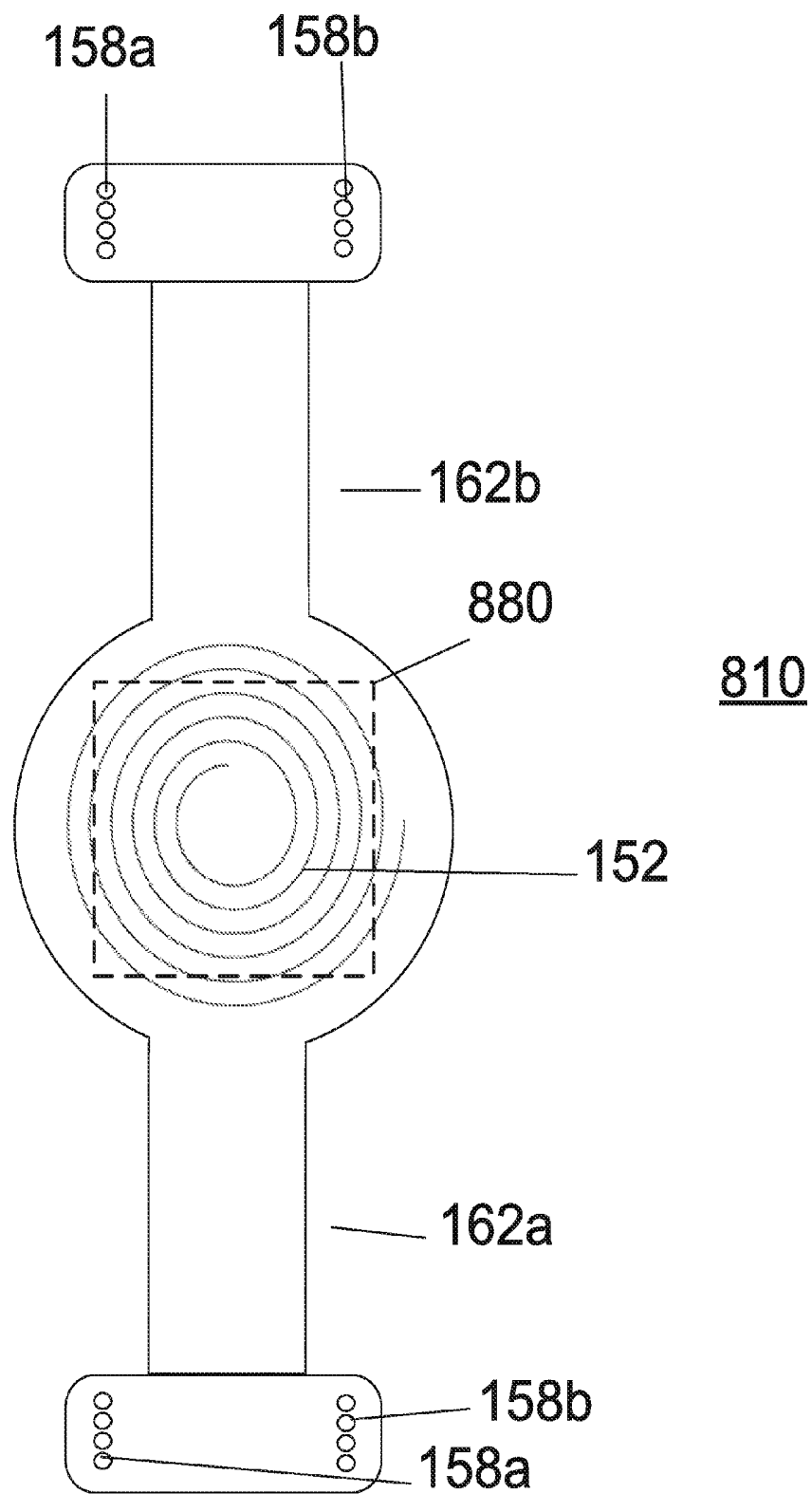

Fig. 11b

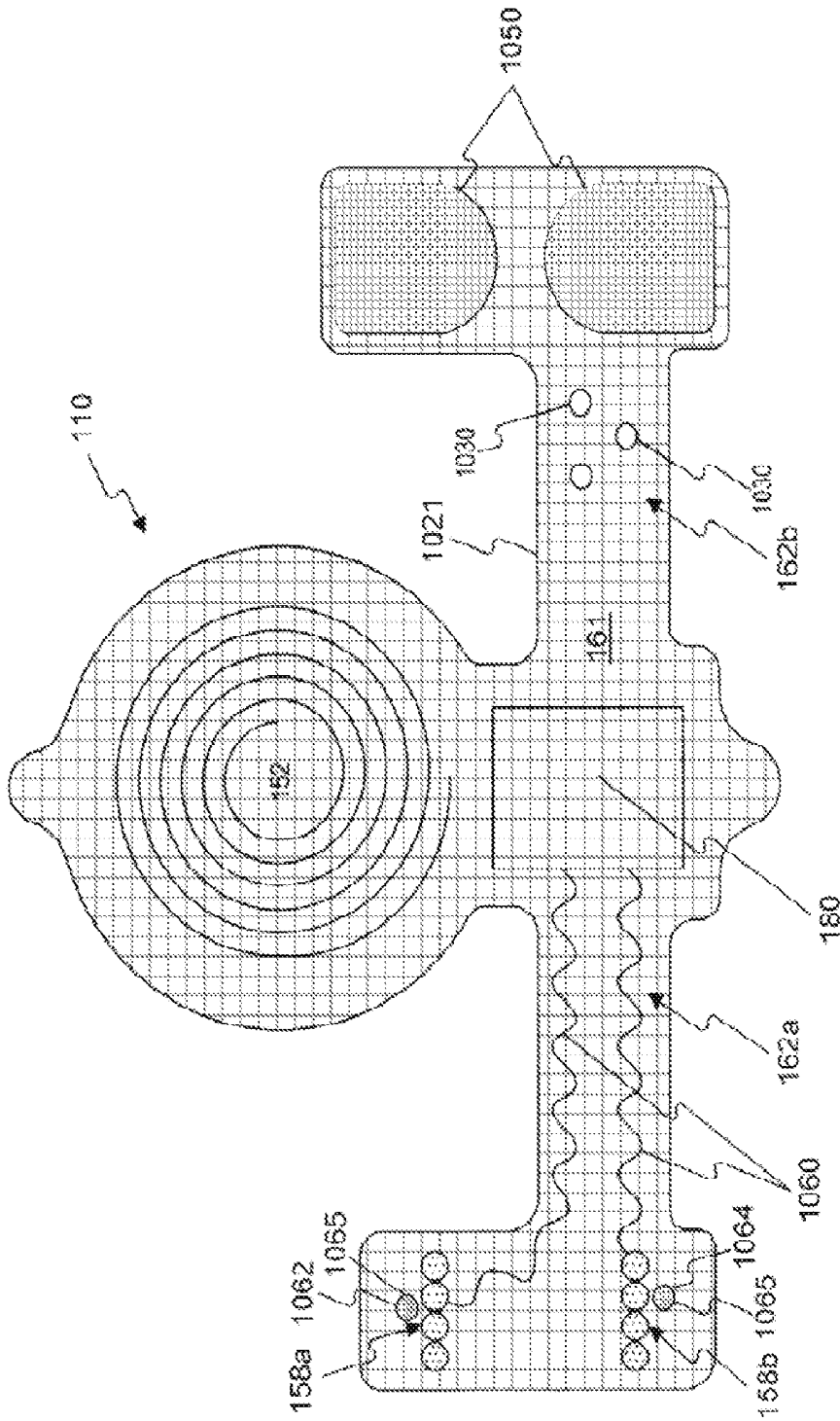

Fig. 12

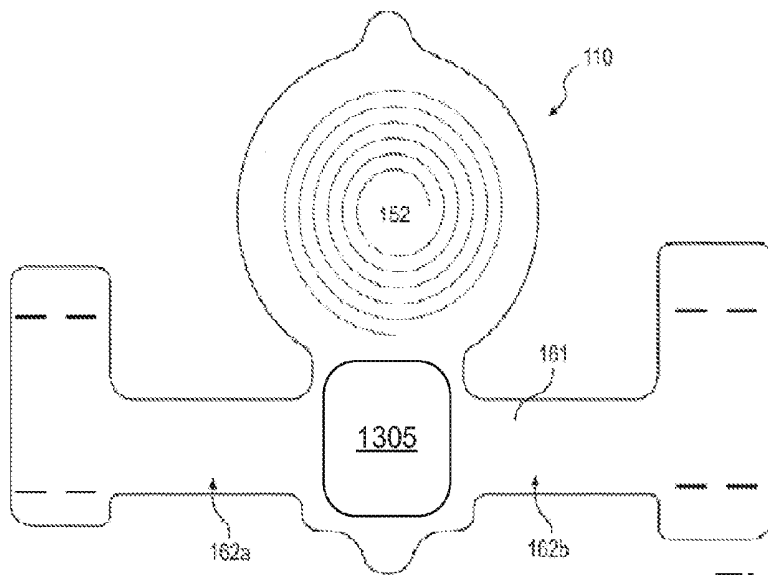

Fig. 13a

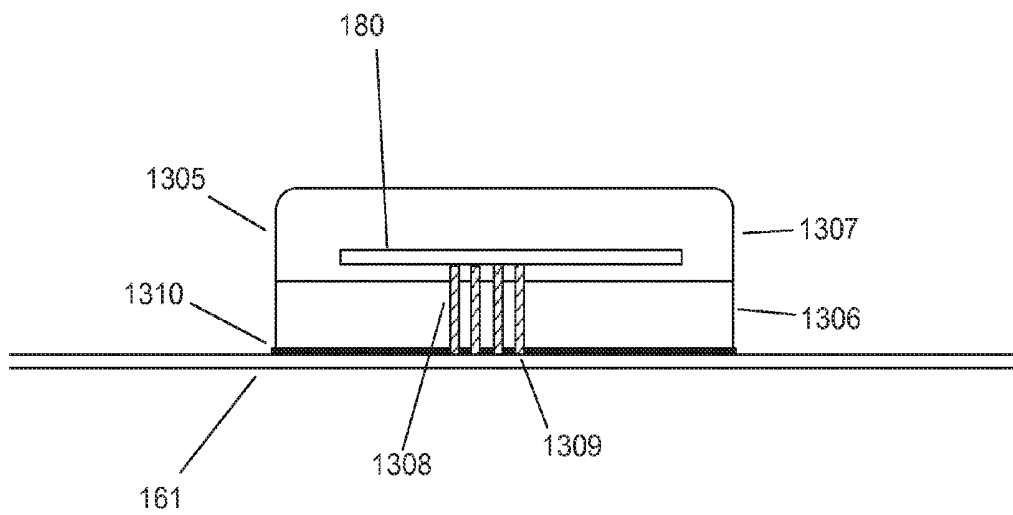

Fig. 13b

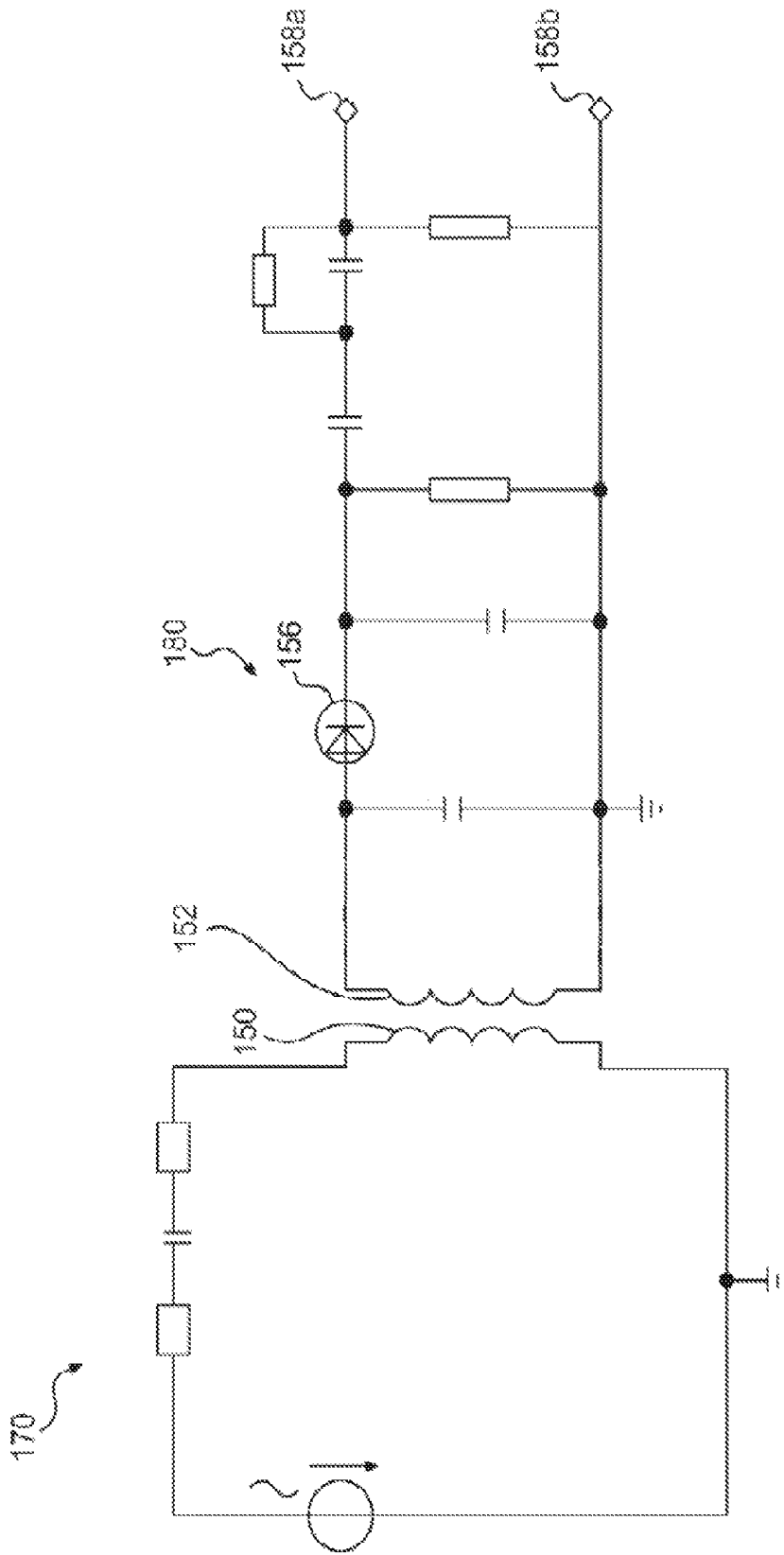

Fig. 14

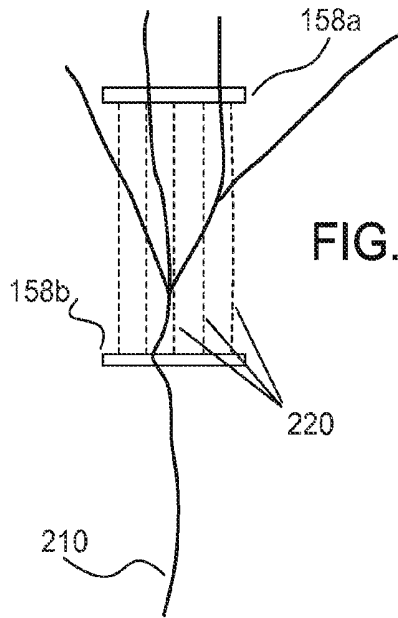

FIG. 15A

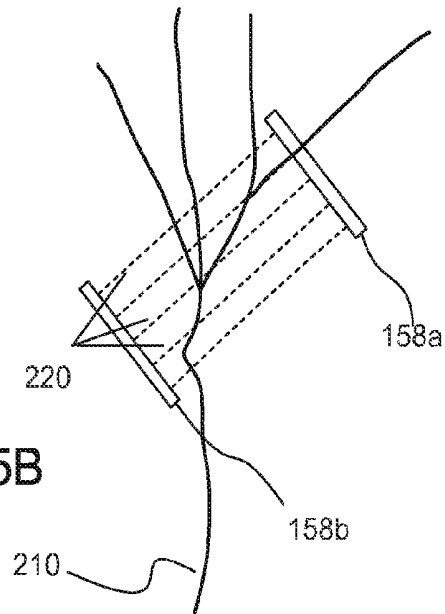

FIG. 15B

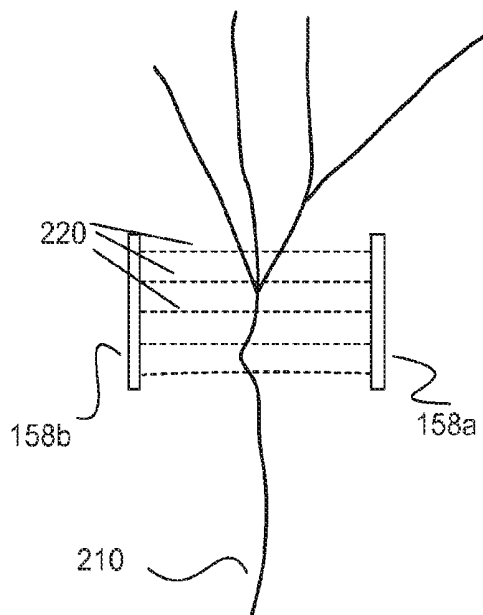

FIG. 15C

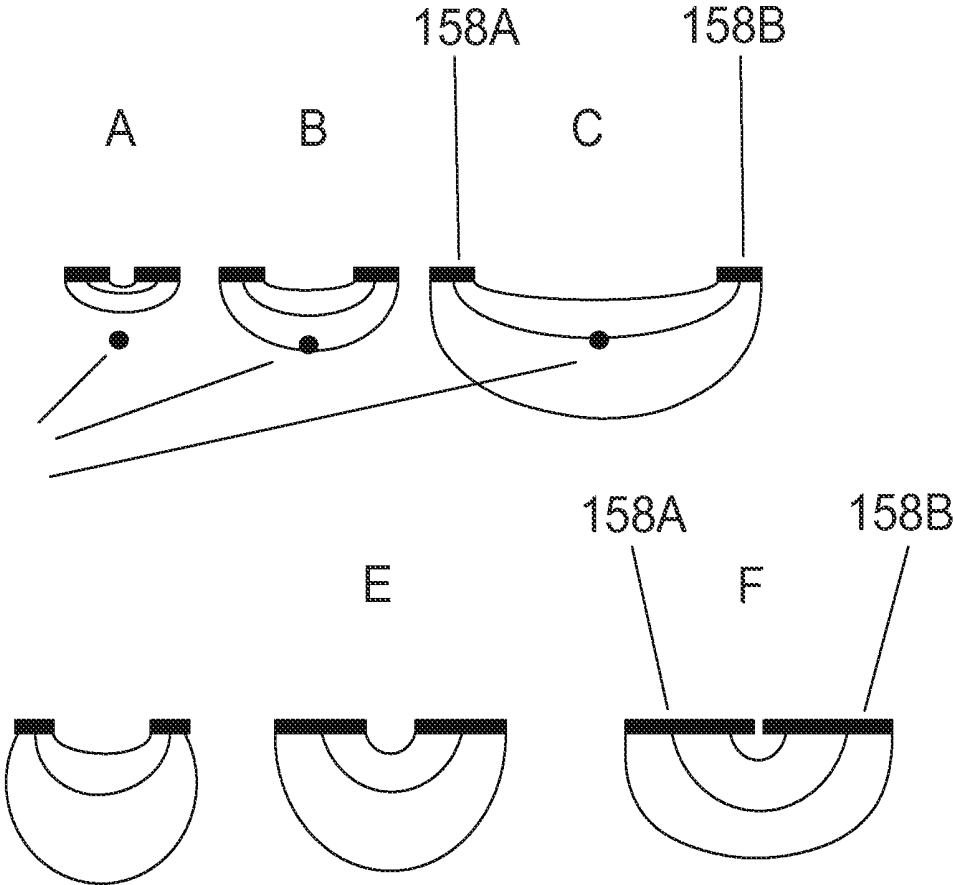

Fig. 16

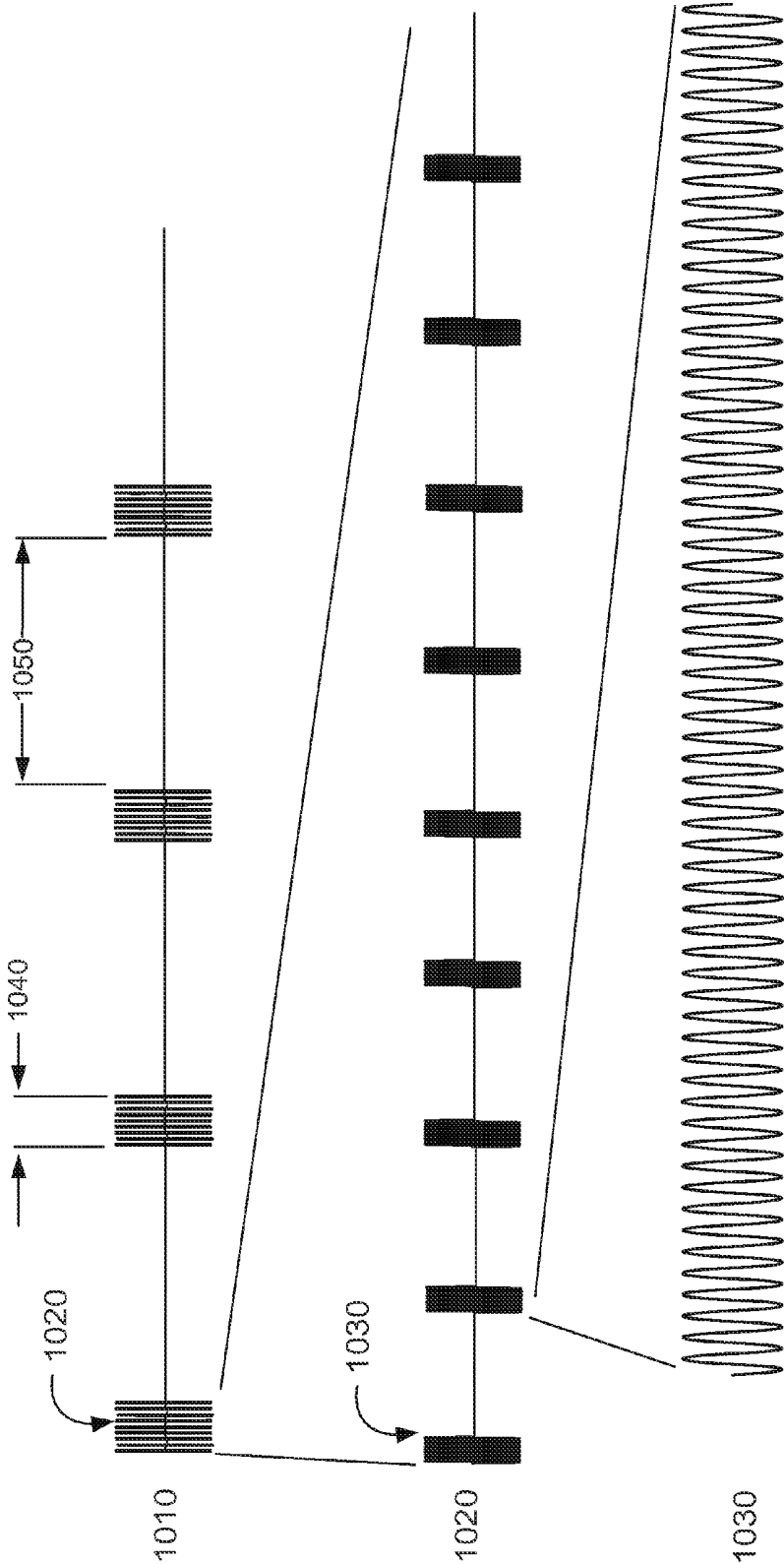

Fig. 17

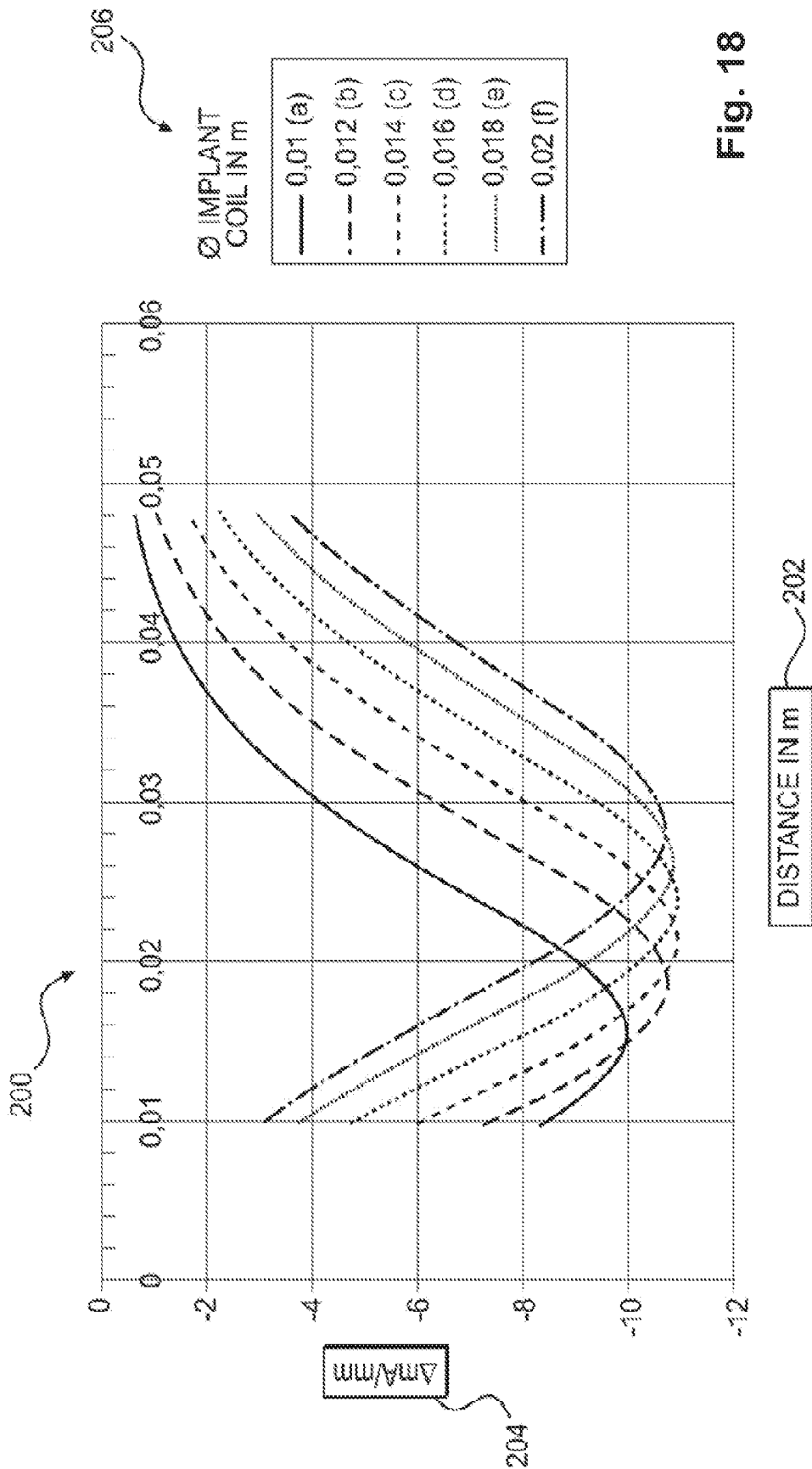

Fig. 18

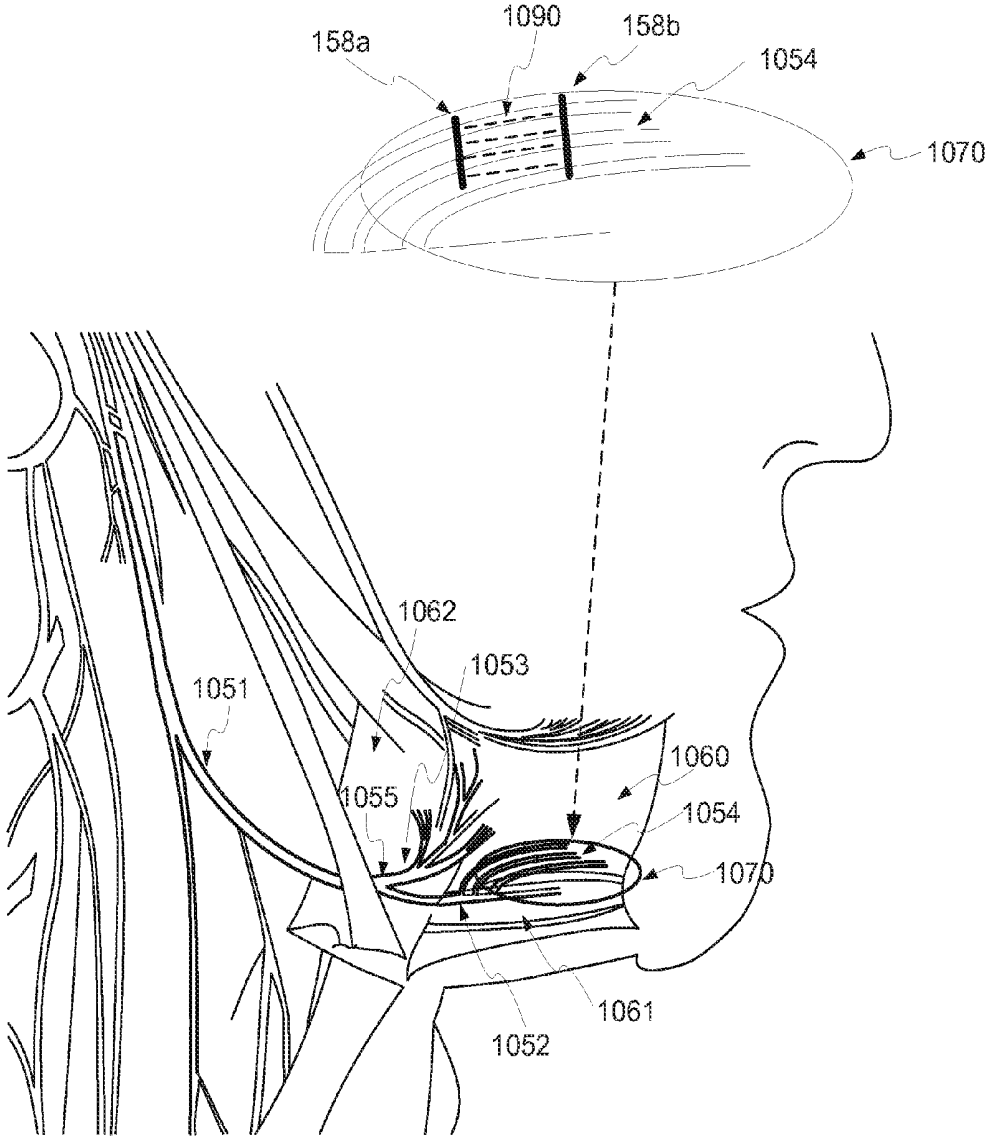

Fig. 19

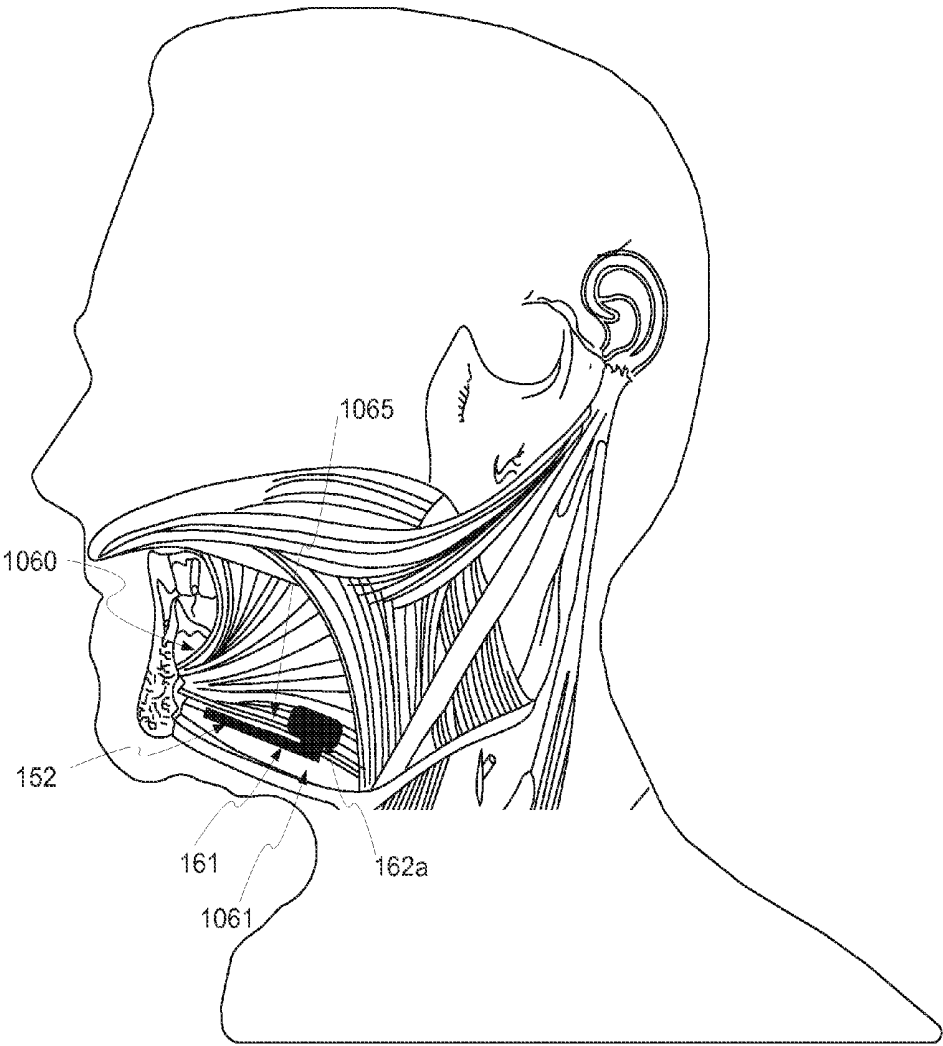

Fig. 20

TREATMENT OF SLEEP APNEA VIA BILATERAL STIMULATION

RELATED APPLICATIONS

This application is a continuation-in-part application of application Ser. No. 14/041,598, filed Sep. 30, 2013, which is a continuation-in-part of application Ser. No. 13/629,690, filed on Sep. 28, 2012, application Ser. No. 13/629,694, filed on Sep. 28, 2012, application Ser. No. 13/629,701, filed on Sep. 28, 2012, application Ser. No. 13/629,712, filed on Sep. 28, 2012, application Ser. No. 13/629,725, filed on Sep. 28, 2012, application Ser. No. 13/629,730, filed on Sep. 28, 2012, application Ser. No. 13/629,741, filed on Sep. 28, 2012, application Ser. No. 13/629,748, filed on Sep. 28, 2012, application Ser. No. 13/629,757, filed on Sep. 28, 2012, application Ser. No. 13/629,762, filed on Sep. 28, 2012, application Ser. No. 13/629,793, filed on Sep. 28, 2012, application Ser. No. 13/629,819, filed on Sep. 28, 2012, application Ser. No. 13/630,392, filed on Sep. 28, 2012, application Ser. No. 13/629,721, filed on Sep. 28, 2012, and application Ser. No. 13/629,686, filed on Sep. 28, 2012, each of which claims the benefit of priority under 35 U.S.C. §119(e) to U.S. Provisional Application No. 61/541,651, filed Sep. 30, 2011, and also to U.S. Provisional Application No. 61/657,424, filed Jun. 8, 2012. Additionally, application Ser. No. 13/629,686, and Ser. No. 13/629,721, are also continuations-in-part of both application Ser. No. 12/642,866, filed Dec. 21, 2009, and of application Ser. No. 12/581,907, filed Oct. 20, 2009. This application also claims priority under 35 U.S.C. §119(e) to U.S. Provisional Application No. 61/836,089, filed Jun. 17, 2013. All of the above referenced applications are incorporated herein by reference in their entirety.

TECHNICAL FIELD

Embodiments of the present disclosure generally relate to devices and methods for modulating a nerve. More particularly, embodiments of the present disclosure relate to devices and methods for modulating a nerve through the delivery of energy via an implantable electrical modulator.

BACKGROUND

Neural modulation presents the opportunity to treat many physiological conditions and disorders by interacting with the body's own natural neural processes. Neural modulation includes inhibition (e.g. blockage), stimulation, modification, regulation, or therapeutic alteration of activity, electrical or chemical, in the central, peripheral, or autonomic nervous system. By modulating the activity of the nervous system, for example through the stimulation of nerves or the blockage of nerve signals, several different goals may be achieved. Motor neurons may be stimulated at appropriate times to cause muscle contractions. Sensory neurons may be blocked, for instance to relieve pain, or stimulated, for instance to provide a signal to a subject. In other examples, modulation of the autonomic nervous system may be used to adjust various involuntary physiological parameters, such as heart rate and blood pressure. Neural modulation may provide the opportunity to treat several diseases or physiological conditions, a few examples of which are described in detail below.

Among the conditions to which neural modulation may be applied are sleep related breathing disorders, such as snoring and obstructive sleep apnea (OSA). OSA is a respiratory

disorder characterized by recurrent episodes of partial or complete obstruction of the upper airway during sleep. During the sleep of a person without OSA, the pharyngeal muscles relax during sleep and gradually collapse, narrowing the airway. The airway narrowing limits the effectiveness of the sleeper's breathing, causing a rise in CO₂ levels in the blood. The increase in CO₂ results in the pharyngeal muscles contracting to open the airway to restore proper breathing. The largest of the pharyngeal muscles responsible for upper airway dilation is the genioglossus muscle, which is one of several different muscles in the tongue. The genioglossus muscle is responsible for forward tongue movement and the stiffening of the anterior pharyngeal wall. In patients with OSA, the neuromuscular activity of the genioglossus muscle is decreased compared to normal individuals, accounting for insufficient response and contraction to open the airway as compared to a normal individual. This lack of response contributes to a partial or total airway obstruction, which significantly limits the effectiveness of the sleeper's breathing. In OSA patients, there are often several airway obstruction events during the night. Because of the obstruction, there is a gradual decrease of oxygen levels in the blood (hypoxemia). Hypoxemia leads to night time arousals, which may be registered by EEG, showing that the brain awakes from any stage of sleep to a short arousal. During the arousal, there is a conscious breath or gasp, which resolves the airway obstruction. An increase in sympathetic tone activity rate through the release of hormones such as epinephrine and noradrenaline also often occurs as a response to hypoxemia. As a result of the increase in sympathetic tone, the heart enlarges in an attempt to pump more blood and increase the blood pressure and heart rate, further arousing the patient. After the resolution of the apnea event, as the patient returns to sleep, the airway collapses again, leading to further arousals.

These repeated arousals, combined with repeated hypoxemia, leaves the patient sleep deprived, which leads to daytime somnolence and worsens cognitive function. This cycle can repeat itself up to hundreds of times per night in severe patients. Thus, the repeated fluctuations in and sympathetic tone and episodes of elevated blood pressure during the night evolve to high blood pressure through the entire day. Subsequently, high blood pressure and increased heart rate may cause other diseases.

Snoring in patients is frequently a result of a partially obstructed airway. Some patients experience relaxation of the pharyngeal muscles to a point that involves partial obstruction not significant enough to cause subsequent arousals during sleep. When the pharyngeal muscles relax and narrow the airway, air must travel through the airway at a higher velocity to maintain a similar volumetric flow rate. Higher velocity flows are more likely to be turbulent. These turbulent flows can cause vibrations in the tissue structure of the airway, producing an audible snoring effect. Snoring may have several adverse effects on both sufferers and those around them. Snoring may lead to hypopnea, a condition in which blood oxygen levels are decreased, resulting in shallower, less restful sleep. Snoring may also be associated with an increased risk of stroke and carotid artery atherosclerosis. Additionally, snoring may be detrimental to the sleep of those around the sufferer.

Efforts for treating both snoring and OSA include Continuous Positive Airway Pressure (CPAP) treatment, which requires the patient to wear a mask through which air is blown into the nostrils to keep the airway open. Other

treatment options include the implantation of rigid inserts in the soft palate to provide structural support, tracheotomies, or tissue ablation.

Another condition to which neural modulation may be applied is the occurrence of migraine headaches. Pain sensation in the head is transmitted to the brain via the occipital nerve, specifically the greater occipital nerve, and the trigeminal nerve. When a subject experiences head pain, such as during a migraine headache, the inhibition of these nerves may serve to decrease or eliminate the sensation of pain.

Neural modulation may also be applied to hypertension. Blood pressure in the body is controlled via multiple feedback mechanisms. For example, baroreceptors in the carotid body in the carotid artery are sensitive to blood pressure changes within the carotid artery. The baroreceptors generate signals that are conducted to the brain via the glossopharyngeal nerve when blood pressure rises, signaling the brain to activate the body's regulation system to lower blood pressure, e.g. through changes to heart rate, and vasodilation/vasoconstriction. Conversely, parasympathetic nerve fibers on and around the renal arteries generate signals that are carried to the kidneys to initiate actions, such as salt retention and the release of angiotensin, which raise blood pressure. Modulating these nerves may provide the ability to exert some external control over blood pressure.

The foregoing are just a few examples of conditions to which neuromodulation may be of benefit, however embodiments of the invention described hereafter are not necessarily limited to treating only the above-described conditions.

SUMMARY

Some embodiments may include a neuromodulation device. The neuromodulation device may include a carrier configured for implantation in a subject, the carrier including a first elongated arm and a second elongated arm, each extending from a central portion of the carrier. The device may further include a first pair of modulation electrodes arranged on the first elongated arm, a second pair of modulation electrodes arranged on the second elongated arm. The carrier may be sized and shaped for implantation in a vicinity of a hypoglossal nerve to be modulated such that the first pair of modulation electrodes is located to modulate a first hypoglossal nerve on a first side of the subject and the second pair of modulation electrodes is located to modulate a second hypoglossal nerve on a second side of the subject.

Some embodiments may include a control unit for controlling an implant unit configured for placement in a body of a subject, the implant unit having at least a first pair and a second pair of modulation electrodes and being configured for bilateral stimulation of a hypoglossal nerve. The control unit may include at least one processing device configured to cause generation of the hypoglossal nerve modulation control signal to be applied to a primary antenna associated with a unit external to the subject's body, and cause application of the hypoglossal nerve modulation control signal to the primary antenna in order to wirelessly transmit the hypoglossal nerve modulation control signal to a secondary antenna included on the implant unit located in the subject's body.

It is to be understood that both the foregoing general description and the following detailed description are exemplary and explanatory only, and are not restrictive of the invention, as claimed.

BRIEF DESCRIPTION OF THE DRAWINGS

The accompanying drawings, which are incorporated in and constitute a part of this specification, illustrate several

embodiments of the disclosure and, together with the description, serve to explain the principles of the embodiments disclosed herein.

FIG. 1 schematically illustrates an implant unit and external unit, according to an exemplary embodiment of the present disclosure.

FIG. 2 is a partially cross-sectioned side view of a subject with an implant unit and external unit, according to an exemplary embodiment of the present disclosure.

FIG. 3 schematically illustrates a system including an implant unit and an external unit, according to an exemplary embodiment of the present disclosure.

FIGS. 4a and 4b illustrate an exemplary embodiment of an external unit.

FIGS. 5a and 5b illustrate a double-layer crossover antenna.

FIG. 6a illustrates an embodiment of a carrier as viewed from the bottom.

FIG. 6b illustrates an embodiment of a carrier in cross section.

FIG. 7 illustrates an embodiment of a carrier including removable tabs.

FIGS. 8a-f illustrate alternate embodiments of a carrier and electronics housing.

FIG. 9 illustrates a medical device console unit of an exemplary embodiment of the present disclosure.

FIG. 10 is a top view of an implant unit, according to an exemplary embodiment of the present disclosure.

FIGS. 11a-b are a top views of alternate embodiments of implant unit, according to an exemplary embodiment of the present disclosure.

FIG. 12 illustrates additional features of an exemplary embodiment of an implant unit according to the present disclosure.

FIGS. 13a-13b illustrate a ceramic implant housing of an exemplary embodiment of the present disclosure.

FIG. 14 illustrates circuitry of an implant unit and an external unit, according to an exemplary embodiment of the present disclosure.

FIG. 15a illustrates a pair of electrodes spaced apart from one another along the longitudinal direction of nerve to facilitate generation of an electric field having field lines substantially parallel to the longitudinal direction of nerve.

FIG. 15b illustrates an embodiment wherein electrodes are spaced apart from one another in a longitudinal direction of at least a portion of nerve.

FIG. 15c illustrates a situation wherein electrodes are spaced apart from one another in a transverse direction of nerve.

FIG. 16 illustrates effects of electrode configuration on the shape of a generated electric field.

FIG. 17 depicts the composition of an exemplary modulation pulse train.

FIG. 18 illustrates a graph of quantities that may be used in determining energy delivery as a function coupling, according to an exemplary disclosed embodiment.

FIG. 19 depicts anatomy of the tongue and associated muscles and nerves.

FIG. 20 illustrates an exemplary implantation position for an implant unit.

DESCRIPTION OF EXEMPLARY EMBODIMENTS

Reference will now be made in detail to exemplary embodiments of the present disclosure, examples of which are illustrated in the accompanying drawings. Wherever

possible, the same reference numbers will be used throughout the drawings to refer to the same or like parts.

Embodiments of the present disclosure relate generally to a device for modulating a nerve through the delivery of energy. Nerve modulation, or neural modulation, includes inhibition (e.g. blockage), stimulation, modification, regulation, or therapeutic alteration of activity, electrical or chemical, in the central, peripheral, or autonomic nervous system. Nerve modulation may take the form of nerve stimulation, which may include providing energy to the nerve to create a voltage change sufficient for the nerve to activate, or propagate an electrical signal of its own. Nerve modulation may also take the form of nerve inhibition, which may include providing energy to the nerve sufficient to prevent the nerve from propagating electrical signals. Nerve inhibition may be performed through the constant application of energy, and may also be performed through the application of enough energy to inhibit the function of the nerve for some time after the application. Other forms of neural modulation may modify the function of a nerve, causing a heightened or lessened degree of sensitivity. As referred to herein, modulation of a nerve may include modulation of an entire nerve and/or modulation of a portion of a nerve. For example, modulation of a motor neuron may be performed to affect only those portions of the neuron that are distal of the location to which energy is applied.

In patients that suffer from a sleep breathing disorder, for example, a primary target response of nerve stimulation may include contraction of a tongue muscle (e.g., the muscle) in order to move the tongue to a position that does not block the patient's airway. In the treatment of migraine headaches, nerve inhibition may be used to reduce or eliminate the sensation of pain. In the treatment of hypertension, neural modulation may be used to increase, decrease, eliminate or otherwise modify nerve signals generated by the body to regulate blood pressure.

While embodiments of the present disclosure may be disclosed for use in patients with specific conditions, the embodiments may be used in conjunction with any patient/portion of a body where nerve modulation may be desired. That is, in addition to use in patients with a sleep breathing disorder, migraine headaches, or hypertension, embodiments of the present disclosure may be used in many other areas, including, but not limited to: deep brain stimulation (e.g., treatment of epilepsy, Parkinson's, and depression); cardiac pace-making, stomach muscle stimulation (e.g., treatment of obesity), back pain, incontinence, menstrual pain, and/or any other condition that may be affected by neural modulation.

FIG. 1 illustrates an implant unit and external unit, according to an exemplary embodiment of the present disclosure. An implant unit **110**, may be configured for implantation in a subject, in a location that permits it to modulate a nerve **115**. The implant unit **110** may be located in a subject such that intervening tissue **111** exists between the implant unit **110** and the nerve **115**. Intervening tissue may include muscle tissue, connective tissue, organ tissue, or any other type of biological tissue. Thus, location of implant unit **110** does not require contact with nerve **115** for effective neuromodulation. The implant unit **110** may also be located directly adjacent to nerve **115**, such that no intervening tissue **111** exists.

In treating a sleep breathing disorder, implant unit **110** may be located on a genioglossus muscle of a patient. Such a location is suitable for modulation of the hypoglossal nerve, branches of which run inside the genioglossus muscle. Implant unit **110** may also be configured for place-

ment in other locations. For example, migraine treatment may require subcutaneous implantation in the back of the neck, near the hairline of a subject, or behind the ear of a subject, to modulate the greater occipital nerve and/or the trigeminal nerve. Treating hypertension may require the implantation of a neuromodulation implant intravascularly inside the renal artery or renal vein (to modulate the parasympathetic renal nerves), either unilaterally or bilaterally, inside the carotid artery or jugular vein (to modulate the glossopharyngeal nerve through the carotid baroreceptors). Alternatively or additionally, treating hypertension may require the implantation of a neuromodulation implant subcutaneously, behind the ear or in the neck, for example, to directly modulate the glossopharyngeal nerve.

External unit **120** may be configured for location external to a patient, either directly contacting, or close to the skin **112** of the patient. External unit **120** may be configured to be affixed to the patient, for example, by adhering to the skin **112** of the patient, or through a band or other device configured to hold external unit **120** in place. Adherence to the skin of external unit **120** may occur such that it is in the vicinity of the location of implant unit **110**.

FIG. 2 illustrates an exemplary embodiment of a neuromodulation system for delivering energy in a patient **100** with a sleep breathing disorder. The system may include an external unit **120** that may be configured for location external to the patient. As illustrated in FIG. 2, external unit **120** may be configured to be affixed to the patient **100**. FIG. 2 illustrates that in a patient **100** with a sleep breathing disorder, the external unit **120** may be configured for placement underneath the patient's chin and/or on the front of patient's neck. The suitability of placement locations may be determined by communication between external unit **120** and implant unit **110**, discussed in greater detail below. In alternate embodiments, for the treatment of conditions other than a sleep breathing disorder, the external unit may be configured to be affixed anywhere suitable on a patient, such as the back of a patient's neck, i.e. for communication with a migraine treatment implant unit, on the outer portion of a patient's abdomen, i.e. for communication with a stomach modulating implant unit, on a patient's back, i.e. for communication with a renal artery modulating implant unit, and/or on any other suitable external location on a patient's skin, depending on the requirements of a particular application.

External unit **120** may further be configured to be affixed to an alternative location proximate to the patient. For example, in one embodiment, the external unit may be configured to fixedly or removably adhere to a strap or a band that may be configured to wrap around a part of a patient's body. Alternatively, or in addition, the external unit may be configured to remain in a desired location external to the patient's body without adhering to that location.

The external unit **120** may include a housing. The housing may include any suitable container configured for retaining components. In addition, while the external unit is illustrated schematically in FIG. 2, the housing may be any suitable size and/or shape and may be rigid or flexible. Non-limiting examples of housings for the external unit **100** include one or more of patches, buttons, or other receptacles having varying shapes and dimensions and constructed of any suitable material. In one embodiment, for example, the housing may include a flexible material such that the external unit may be configured to conform to a desired location. For example, as illustrated in FIG. 2, the external unit may include a skin patch, which, in turn, may include a flexible substrate. The material of the flexible substrate may include,

but is not limited to, plastic, silicone, woven natural fibers, and other suitable polymers, copolymers, and combinations thereof. Any portion of external unit **120** may be flexible or rigid, depending on the requirements of a particular application.

As previously discussed, in some embodiments external unit **120** may be configured to adhere to a desired location. Accordingly, in some embodiments, at least one side of the housing may include an adhesive material. The adhesive material may include a biocompatible material and may allow for a patient to adhere the external unit to the desired location and remove the external unit upon completion of use. The adhesive may be configured for single or multiple uses of the external unit. Suitable adhesive materials may include, but are not limited to biocompatible glues, starches, elastomers, thermoplastics, and emulsions.

FIG. 3 schematically illustrates a system including external unit **120** and an implant unit **110**. In some embodiments, internal unit **110** may be configured as a unit to be implanted into the body of a patient, and external unit **120** may be configured to send signals to and/or receive signals from implant unit **110**.

As shown in FIG. 3, various components may be included within a housing of external unit **120** or otherwise associated with external unit **120**. As illustrated in FIG. 3, at least one processor **144** may be associated with external unit **120**. For example, the at least one processor **144** may be located within the housing of external unit **120**. In alternative embodiments, the at least one processor may be configured for wired or wireless communication with the external unit from a location external to the housing.

The at least one processor may include any electric circuit that may be configured to perform a logic operation on at least one input variable. The at least one processor may therefore include one or more integrated circuits, microchips, microcontrollers, and microprocessors, which may be all or part of a central processing unit (CPU), a digital signal processor (DSP), a field programmable gate array (FPGA), or any other circuit known to those skilled in the art that may be suitable for executing instructions or performing logic operations.

FIG. 3 illustrates that the external unit **120** may further be associated with a power source **140**. The power source may be removably coupleable to the external unit at an exterior location relative to external unit. Alternatively, as shown in FIG. 3, power source **140** may be permanently or removably coupled to a location within external unit **120**. The power source may further include any suitable source of power configured to be in electrical communication with the processor. In one embodiment, for example the power source **140** may include a battery.

The power source may be configured to power various components within the external unit. As illustrated in FIG. 3, power source **140** may be configured to provide power to the processor **144**. In addition, the power source **140** may be configured to provide power to a signal source **142**. The signal source **142** may be in communication with the processor **144** and may include any device configured to generate a signal (e.g., a sinusoidal signal, square wave, triangle wave, microwave, radio-frequency (RF) signal, or any other type of electromagnetic signal). Signal source **142** may include, but is not limited to, a waveform generator that may be configured to generate alternating current (AC) signals and/or direct current (DC) signals. In one embodiment, for example, signal source **142** may be configured to generate an AC signal for transmission to one or more other components. Signal source **142** may be configured to gen-

erate a signal of any suitable frequency. In some embodiments, signal source **142** may be configured to generate a signal having a frequency of from about 6.5 MHz to about 13.6 MHz. In additional embodiments, signal source **142** may be configured to generate a signal having a frequency of from about 7.4 to about 8.8 MHz. In further embodiments, signal source **142** may generate a signal having a frequency as low as 90 kHz or as high as 28 MHz.

Signal source **142** may be configured for direct or indirect electrical communication with an amplifier **146**. The amplifier may include any suitable device configured to amplify one or more signals generated from signal source **142**. Amplifier **146** may include one or more of various types of amplification devices, including, for example, transistor based devices, operational amplifiers, RF amplifiers, power amplifiers, or any other type of device that can increase the gain associated one or more aspects of a signal. The amplifier may further be configured to output the amplified signals to one or more components within external unit **120**.

External unit may **120** additionally include a memory unit **143**. Processor **144** may communicate with memory unit **143**, for example, to store and retrieve data. Stored and retrieved data may include, for example, information about therapy parameters and information about implant unit **110** and external unit **120**. The use of memory unit **143** is explained in greater detail below. Memory unit **143** may be any suitable for of non-transient computer readable storage medium.

External unit **120** may also include communications interface **145**, which may be provided to permit external unit **120** to communicate with other devices, such as programming devices and data analysis device. Further details regarding communications interface **145** are included below.

The external unit may additionally include a primary antenna **150**. The primary antenna may be configured as part of a circuit within external unit **120** and may be coupled either directly or indirectly to various components in external unit **120**. For example, as shown in FIG. 3, primary antenna **150** may be configured for communication with the amplifier **146**.

The primary antenna may include any conductive structure that may be configured to create an electromagnetic field. The primary antenna may further be of any suitable size, shape, and/or configuration. The size, shape, and/or configuration may be determined by the size of the patient, the placement location of the implant unit, the size and/or shape of the implant unit, the amount of energy required to modulate a nerve, a location of a nerve to be modulated, the type of receiving electronics present on the implant unit, etc. The primary antenna may include any suitable antenna known to those skilled in the art that may be configured to send and/or receive signals. Suitable antennas may include, but are not limited to, a long-wire antenna, a patch antenna, a helical antenna, etc. In one embodiment, for example, as illustrated in FIG. 3, primary antenna **150** may include a coil antenna. Such a coil antenna may be made from any suitable conductive material and may be configured to include any suitable arrangement of conductive coils (e.g., diameter, number of coils, layout of coils, etc.). A coil antenna suitable for use as primary antenna **150** may have a diameter of between about 1 cm and 10 cm, and may be circular or oval shaped. In some embodiments, a coil antenna may have a diameter between 5 cm and 7 cm, and may be oval shaped. A coil antenna suitable for use as primary antenna **150** may have any number of windings, e.g. 4, 8, 12, or more. A coil antenna suitable for use as primary antenna **150** may have a wire diameter between about 0.1 mm and 2 mm. These

antenna parameters are exemplary only, and may be adjusted above or below the ranges given to achieve suitable results.

As noted, implant unit **110** may be configured to be implanted in a patient's body (e.g., beneath the patient's skin). FIG. **2** illustrates that the implant unit **110** may be configured to be implanted for modulation of a nerve associated with a muscle of the subject's tongue **130**. Modulating a nerve associated with a muscle of the subject's tongue **130** may include stimulation to cause a muscle contraction. In further embodiments, the implant unit may be configured to be placed in conjunction with any nerve that one may desire to modulate. For example, modulation of the occipital nerve, the greater occipital nerve, and/or the trigeminal nerve may be useful for treating pain sensation in the head, such as that from migraines. Modulation of parasympathetic nerve fibers on and around the renal arteries (i.e., the renal nerves), the vagus nerve, and/or the glossopharyngeal nerve may be useful for treating hypertension. Additionally, any nerve of the peripheral nervous system (both spinal and cranial), including motor neurons, sensory neurons, sympathetic neurons and parasympathetic neurons, may be modulated to achieve a desired effect.

Implant unit **110** may be formed of any materials suitable for implantation into the body of a patient. In some embodiments, implant unit **110** may include a flexible carrier **161** (FIG. **4**) including a flexible, biocompatible material. Such materials may include, for example, silicone, polyimides, phenyltrimethoxysilane (PTMS), polymethyl methacrylate (PMMA), Parylene C, polyimide, liquid polyimide, laminated polyimide, black epoxy, polyether ether ketone (PEEK), Liquid Crystal Polymer (LCP), Kapton, etc. Implant unit **110** may further include circuitry including conductive materials, such as gold, platinum, titanium, or any other biocompatible conductive material or combination of materials. Implant unit **110** and flexible carrier **161** may also be fabricated with a thickness suitable for implantation under a patient's skin. Implant **110** may have thickness of less than about 4 mm or less than about 2 mm.

Other components that may be included in or otherwise associated with the implant unit are illustrated in FIG. **3**. For example, implant unit **110** may include a secondary antenna **152** mounted onto or integrated with flexible carrier **161**. Similar to the primary antenna, the secondary antenna may include any suitable antenna known to those skilled in the art that may be configured to send and/or receive signals. The secondary antenna may include any suitable size, shape, and/or configuration. The size, shape and/or configuration may be determined by the size of the patient, the placement location of the implant unit, the amount of energy required to modulate the nerve, etc. Suitable antennas may include, but are not limited to, a long-wire antenna, a patch antenna, a helical antenna, etc. In some embodiments, for example, secondary antenna **152** may include a coil antenna having a circular shape (see also FIG. **10**) or oval shape. Such a coil antenna may be made from any suitable conductive material and may be configured to include any suitable arrangement of conductive coils (e.g., diameter, number of coils, layout of coils, etc.). A coil antenna suitable for use as secondary antenna **152** may have a diameter of between about 5 mm and 30 mm, and may be circular or oval shaped. A coil antenna suitable for use as secondary antenna **152** may have any number of windings, e.g. 4, 15, 20, 30, or 50. A coil antenna suitable for use as secondary antenna **152** may have a wire diameter between about 0.01 mm and 1 mm. These antenna parameters are exemplary only, and may be adjusted above or below the ranges given to achieve suitable results.

FIGS. **4a** and **4b** illustrate an exemplary embodiment of external unit **120**, including features that may be found in any combination in other embodiments. FIG. **4a** illustrates a side view of external unit **120**, depicting carrier **1201** and electronics housing **1202**.

Carrier **1201** may include a skin patch configured for adherence to the skin of a subject, for example through adhesives of mechanical means. Carrier **1201** may be flexible or rigid, or may have flexible portions and rigid portions. Carrier **1201** and may include a primary antenna **150**, for example, a double-layer crossover antenna **1101** such as that illustrated in FIGS. **5a** and **5b**. Carrier **1201** may also include power source **140**, such as a paper battery, thin film battery, or other type of substantially flat and/or flexible battery. Carrier **1201** may also include any other type of battery or power source. Carrier **1201** may also include a connector **1203** configured for selectively or removably connecting carrier **1201** to electronics housing **1202**. Connector **1203** may extend or protrude from carrier **1201**. Connector **1203** may be configured to be received by a recess **1204** of electronics housing **1202**. Connector **1203** may be configured as a non-pouch connector, configured to provide a selective connection to electronics housing **1204** without the substantial use of concave feature. Connector **1203** may include, for example a peg, and may have flexible arms. Connector **1203** may further include a magnetic connection, a velcro connection, and/or a snap dome connection. Connector **1203** may also include a locating feature, configured to locate electronics housing **1202** at a specific height, axial location, and/or axial orientation with respect to carrier **1201**. A locating feature of connector **1203** may further include pegs, rings, boxes, ellipses, bumps, etc. Connector **1203** may be centered on carrier **1201**, may be offset from the center by a predetermined amount, or may be provided at any other suitable location of carrier **1201**. Multiple connectors **1203** may be provided on carrier **1201**. Connector **1203** may be configured such that removal from electronics housing **1202** causes breakage of connector **1203**. Such a feature may be desirable to prevent re-use of carrier **1201**, which may lose some efficacy through continued use.

Direct contact between primary antenna **150** and the skin of a subject may result in alterations of the electrical properties of primary antenna **150**. This may be due to two effects. First, the skin of a subject is a resistive volume conductor, and creating electrical contact between primary antenna **150** and the skin may result in the skin becoming part of an electric circuit including the primary antenna. Thus, when primary antenna **150** is energized, current may flow through the skin, altering the electrical properties of primary antenna **150**. Second, when the subject sweats, the generated moisture may also act as a resistive conductor, creating electrical pathways that did not exist previously. These effects may occur even when there is no direct contact between the primary antenna **150** and the skin, for example, when an adhesive layer is interposed between the primary antenna **150** and the skin. Because many adhesives are not electrically insulating, and may absorb moisture from a subject's skin, these effects can occur without direct contact between the antenna and the skin. In some embodiments, processor **144** may be configured to detect the altered properties of primary antenna **150** and take these into account when generating modulation and sub-modulation control signals for transmission to an implant unit **110**.

In some embodiments, carrier **1201** may include a buffered antenna, as illustrated in FIGS. **6a-b** and **22** (not drawn to scale), to counteract (e.g., reduce or eliminate) the above-

described effects. FIG. 6a illustrates an embodiment of carrier 1201 as viewed from the bottom. FIG. 6b illustrates an embodiment of carrier 1201 in cross section. Carrier 1201 may include one or more structures for separating an antenna from the skin of a subject. In some embodiments, carrier 1201 may include a buffer layer 2150 that provides an air gap 2160 between the skin of a subject and the antenna. Carrier 1201 may also include a top layer 2130 and a top center region 2140.

As illustrated in FIGS. 6a-b, buffer layer 2150 may be disposed on the flexible carrier at a position so as to be between the antenna and the skin of the subject when carrier 1201 is in use. Buffer layer 2150 may include any suitable material or structure to provide or establish an air gap 2160 between the antenna 150 and the skin of the subject. As used herein, air gap 2160 may include any space, area, or region between the skin of the subject and antenna 150 not filled by a solid material. In some embodiments, buffer layer 2150 may include a single layer. In other embodiments, buffer layer 2150 may include multiple sub-layers (e.g., two, three, or more sub-layers). In still other embodiments, buffer layer 2150 may include an extension of one or more structures associated with carrier 1201 in order to move antenna 150 away from a subject's skin.

The air gap 2160 provided may be contiguous or may reside within or among various structures associated with buffer layer 2150. For example, in some embodiments, air gap 2160 may include a space or region free or relatively free of structures, such as air gap 2160 shown in FIG. 6b, which includes an air filled volume created between the skin of the subject and antenna 150 by the structure of buffer layer 2150. In other embodiments, air gap 2160 may be formed within or between structures associated with buffer layer 2150. For example, air gap 2160 may be formed by one or more porous materials, including open or close cell foams, fibrous mats, woven materials, fabrics, perforated sheet materials, meshes, or any other material or structure having air spaces within boundaries of the material or structure. Further, buffer layer 2150 may include dielectric materials, hydrophobic closed cell foams, open celled foams, cotton and other natural fibers, porous cellulose based materials, synthetic fibers, and any other material or structure suitable for establishing air gap 2160.

Air gap 2160 need not contain only air. Rather, other materials, fluids, or gases may be provided within air gap 2160. For example, in some cases, air gap 2160 may include carbon dioxide, nitrogen, argon, or any other suitable gases or materials.

FIGS. 6a and 6b provide a diagrammatic depiction of a carrier 1201 including an exemplary buffer layer 2150, consistent with the present disclosure. In the structure shown in FIGS. 6a and 6b, air gap 2160 is provided by a buffer layer 2150 having multiple sub-layers. Specifically, buffer layer 2150 may include a separation sub-layer 2110 and an adhesive sub-layer 2120. Separation sub-layer 2110, which may or may not be included in buffer layer 2150, may include any structure for isolating or otherwise separating antenna 150 from a surface of the subject's skin. In the embodiment shown in FIGS. 6a and 6b, air gap 2160 may be established through patterning of adhesive sub-layer 2120. For example, as shown, adhesive sub-layer 2120 may be disposed around a perimeter of separation sub-layer 2110, and air gap 2160 may be established in a region in the middle of adhesive sub-layer 2120. Of course, other configurations of adhesive sub-layer 2120 may also be possible. For example, air gap 2160 may be formed between any pattern of features associated with adhesive sub-layer 2120, includ-

ing, for example, adhesive stripes, dots, meshes, etc. For example, adhesive sub-layer 2120 may include a series of discrete adhesive dots or lines, a mesh-pattern of adhesive material, or any other pattern suitable for establishing air gap 2160.

While in some embodiments, air gap 2160 may be established by adhesive sub-layer 2120 or by any other sub-layer of buffer layer 2150, in other embodiments, air gap 2160 may be established by separation sub-layer 2110. In such embodiments, separation sub-layer 2110 may be made to include various patterns (e.g., perforations, meshes, islands, bumps, pillars, etc.) to provide air gap 2160. Separation sub-layer 2110 may also be formed of a various types of materials. For example, separation sub-layer 2110 may include open or closed cell foam, fabric, paper, perforated sheet materials, or any other material suitable for providing air gaps or spaces therewithin. Separation sub-layer 2110 may be formed of insulating material, such as a dielectric material.

In some embodiments, buffer layer 2150 may be formed by extensions of another layer (e.g., a top layer 2130) associated with carrier 1201. For example, top layer 2130 may include legs or extension portions that extend below antenna 150 such that when in use, antenna 150 is positioned at a location above the subject's skin.

Air gap 2160 may have any suitable dimensions. In some embodiments, air gap 2160 may be between 250 microns 1 mm in height. In other embodiments air gap 2160 may be between 1 mm and 5 mm in height.

The buffered antenna, as illustrated in FIGS. 6a and 6b may serve to electrically insulate and/or isolate primary antenna 150 from the skin and/or the sweat of a subject, thus eliminating or reducing the alterations to electrical properties of the antenna that may result from contact with the skin and/or sweat of the subject. A buffered antenna may be constructed with either or both of buffered layer 2110 and air gap 2160 disposed within window region 2150.

In some embodiments, carrier 1201 may be provided with removable tabs, as shown in FIG. 7 for altering a size of the carrier. Users of carrier 1201 differ significantly in size and shape. Some users may have larger neck and/or chin areas, some may have smaller. Some users may find require more adhesive area to maintain comfort during a therapeutic period. To accommodate various preferences, carrier 1201 may be provided with removable tabs 2220 at either end, wherein the tabs are provided with a perforated detachment portion where they connect to the carrier 1201. A user who desires the increased adhesive area may leave the tabs intact, while a user desiring a smaller adhesive area may tear the tabs 2220 along the perforated detachment portion to remove them. In alternative embodiments, tabs 2220 may be sized and shape to accommodate the thumbs of a user. In still other embodiments, non-removable tabs sized and shaped to accommodate the thumbs of a user may be provided. In some embodiments, removable tabs 2220 may be provided without adhesive, to be used during attachment of carrier 1201 and subsequently removed. Non-adhesive removable tabs 2220 may permit a user to hold carrier 1201 without accidentally sticking it to their fingers.

Returning now to FIGS. 4a and 4b, electronics housing 1202 is illustrated in side view in FIG. 4a and in a bottom view in FIG. 4b. Electronics housing 1202 may include electronics portion 1205, which may be arranged inside electronics housing 1202 in any manner that is suitable. Electronics portion 1205 may include various components, further discussed below, of external unit 120. For example, electronics portion 1205 may include any combination of at

least one processor **144** associated with external unit **120**, a power source **140**, such as a battery, a primary antenna **152**, and an electrical circuit **170**. Electronics portion **1205** may also include any other component described herein as associated with external unit **120**. Additional components may also be recognized by those of skill in the art.

Electronics housing **1202** may include a recess **1204** configured to receive connector **1203**. Electronics housing **1202** may include at least one electrical connector **1210**, **1211**, **1212**. Electrical connectors **1210**, **1211**, **1212** may be arranged with pairs of electrical contacts, as shown in FIG. **4b**, or with any other number of electrical contacts. The pair of electrical contacts of each electrical connector **1210**, **1211**, **1212** may be continuously electrically connected with each other inside of housing **1202**, such that the pair of electrical contacts represents a single connection point to a circuit. In such a configuration, it is only necessary that one of the electrical contacts within a pair be connected. Electrical connectors **1210**, **1211**, and **1212** may thus include redundant electrical contacts. The electrical contacts of each electrical connector **1210**, **1211**, **1212** may also represent opposite ends of a circuit, for example, the positive and negative ends of a battery charging circuit. In an exemplary embodiment, as shown in FIG. **4b**, electrical connectors **1210**, **1211**, and **1212** are configured so as to maintain electrical contact with an exposed electrical contact portion **1108** independent of an axial orientation of electronics housing **1202**. Connection between any or all of electrical connectors **1210**, **1211**, **1212** and exposed electrical contact portions **1108** may thus be established and maintained irrespective of relative axial positions of carrier **1201** and housing **1202**. Thus, when connector **1203** is received by recess **1204**, housing **1202** may rotate with respect to carrier **1201** without interrupting electrical contact between at least one of electrical connectors **1210**, **1211**, **1212** and exposed electrical contact portions **1108**. Axial orientation independence may be achieved, for example, through the use of circular exposed electrical contact portions **1108** and each of a pair of contacts of electrical connectors **1210**, **1211**, **1212** disposed equidistant from a center of recess **1204** at a radius approximately equal to that of a corresponding exposed electrical contact portion **1108**. In this fashion, even if exposed electrical contact portion **1108** includes a discontinuous circle, at least one electrical contact of electrical connectors **1210**, **1211**, and **1212** may make contact. In FIG. **4b**, electrical connectors **1210**, **1211**, **1212** are illustrated as pairs of rectangular electrical contacts. Electrical connectors **1210**, **1211**, **1212**, however, may include any number of contacts, be configured as continuous or discontinuous circles, or have any other suitable shape or configuration.

One exemplary embodiment may operate as follows. As shown in FIG. **4b**, electronics housing **1202** may include more electrical connectors **1210**, **1211**, **1212**, than a carrier **1201** includes exposed electrical contact portions **1108**. In the illustrated embodiments, electronics housing **1202** includes three electrical connectors **1210**, **1211**, and **1212**, while a double-layer crossover antenna **1101** includes two exposed electrical contact portions **1108**. In such an embodiment, two electrical connectors **1211** and **1212** may be configured with continuously electrically connected electrical contacts, such that each connector makes contact with a different exposed electrical contact portion **1108**, where the exposed electrical contact portions **1108** represent opposite ends of double layer crossover antenna **1101**. Thus, antenna **1101** may be electrically connected to the electrical components contained in electronics portion **1205**. When connected to carrier **1201** in this configuration, electrical con-

nectors **1210** may not make contact with any electrodes. In this embodiment, electrical connectors **1210** may be reserved to function as opposite ends of a battery charging circuit, in order to charge a battery contained in electronics portion **1205** when electronics housing **1202** is not being used for therapy. A battery charger unit may be provided with a non-breakable connector similar to that of non-pouch connector **1203**, and configured to engage with recess **1204**. Upon engaging with recess **1204**, electrode contacts of the battery charger unit may contact electrical connectors **1210** to charge a battery contained within electronics portion **1205**.

In an additional embodiment consistent with the present disclosure, an activator chip may include electronics housing **1202**. Processor **144** may be configured to activate when at least one of electrical connectors **1210**, **1211**, **1212** contact exposed electrical contact portions **1108** included in carrier **1201**. In this manner, an electronics housing **1202** may be charged and left dormant for many days prior to activation. Simply connecting electronics housing **1202** to carrier **1201** (and inducing contact between an electrical connector **1210**, **1211**, **1212** and an electrode portion **1108**) may cause the processor to activate. Upon activation, processor **144** may be configured to enter a specific mode of operation, such as a calibration mode (for calibrating the processor after placement of the carrier on the skin), a placement mode (for assisting a user to properly place the carrier on the skin), and/or a therapy mode (to begin a therapy session). The various modes of processor **144** may include waiting periods at the beginning, end, or at any time during. For example, a placement mode may include a waiting period at the end of the mode to provide a period during which a subject may fall asleep. A therapy mode may include a similar waiting period at the beginning of the mode. Additionally or alternatively, processor **144** may be configured to provide waiting periods separate from the described modes, in order to provide a desired temporal spacing between system activities.

In some embodiments, housing **1202** may include features to communicate with a user. For example, one or more LED lights and/or one or more audio devices may be provided. LEDs and audio devices may be provided to communicate various pieces of information to a user, such as low battery warnings, indications of activity, malfunction alerts, indications of connectivity (e.g. connections to electrical components on carrier **1201**).

Another embodiment consistent with the present disclosure may include a flexible electronics housing **1802**. FIGS. **8a-8f** illustrates an embodiment including a flexible electronics housing **1802**. Utilizing flexible electronics housing **1802** may provide benefits with respect to the size and shape of the electronics housing component. An electronics housing must be large enough to accommodate the various components contained inside, such as electronic circuitry and a battery. It may be beneficial to house the necessary components in a flexible electronics housing **1802** with increased lateral dimensions and decreased vertical dimensions, in order to create a more comfortable experience for a user. A lower profile flexible electronics housing **1802** may also be less likely to catch its edges on bedclothes during a sleeping period. Additionally, when increasing lateral dimensions, it may be beneficial for the housing to be flexible, so as to better conform to the body contour of the wearer. Flexible electronics housing **1802** may be achieved through the use of flexible components, such as a flexible circuit board **1803** accommodating processor **144**. Flexible electronics housing **1802** may be between 10 and 50 mm in height, and may be at least three times wider in a lateral

dimension than in a height dimension. In one embodiment, flexible electronics housing **1802** may be elliptical in shape, 14 mm high and having elliptical diameters of 40 mm and 50 mm.

Flexible electronics housing **1802** may further include all of the same functionality and components as described above with respect to electronics housing **1202**, for example, battery **1804**, electrical connectors **1805** (not shown), and recess **1806**. Flexible electronics housing **1802** may also be configured to contain a primary antenna. Recess **1806** may be a connection portion configured to engage with a non-pouch connector **1203** of carrier **1201**. Some embodiments may include a plurality of recesses **1806**, for example, two or four recesses located near edges of the housing, as shown in FIG. **8b**, or a centrally located recess and a plurality of recess located near edges of the housing, as shown in FIG. **8c**. The flexibility of flexible electronics housing **1802** may permit the housing to better conform to the contours of a patient's body when secured via connector **1203** and carrier **1201**. Flexible electronics housing **1802** may include a rigid portion **1807** in the center in which electrical connectors **1805** are located. Rigid portion **1807** may be substantially inflexible. Rigid portion **1807** may ensure that electrical connectors **1805** maintain contact with exposed electrical contact portions **1108** of carrier **1201**. Rigid portion **1807** may also accommodate a rigid battery **1804**, or any other component in the housing required to be rigid. In some embodiments, battery **1804** may provide the structure that ensures the rigidity of rigid portion **1807**. Any combination of the components within flexible housing **1802** may be flexible and/or rigid as required.

It is not necessary for flexible electronics housing **1802** to maintain contact with carrier **1201** in portions away from electrical connectors **1805** and exposed electrical contact portions **1108**. For example, if carrier **1201** is contoured to a body of a subject, and bends away from flexible electronics housing **1802**, electrical communication may be maintained through rigid portion **1807**, as illustrated, for example, in FIG. **8e**. In some embodiments, each end of flexible housing **1802** may be configured to flex as much as sixty degrees away from a flat plane. In embodiments that include rigid portion **1807**, bending may begin at a portion immediately outside of rigid portion **1807**. FIG. **8f** illustrates a flexible housing **1802** including a rigid portion **1807** with flexed ends bent at an angle α .

Flexible housing **1802** may be constructed of any suitable flexible material, such as, for example, silicone, PMMA, PEEK, polypropylene, and polystyrene. Flexible housing **1802** may be constructed from a top portion and a bottom portion, with the components being placed inside prior to sealing the top portion to the bottom portion. Flexible housing **1802** may also be constructed through overmolding techniques, wherein a flexible material is molded over and around the required interior components. Flexible housing **1802** may be manufactured with additives, for example to include particulate substances to provide color or ferrite substances, which may reflect and/or absorb a radiofrequency signal produced by a primary antenna contained within flexible housing **1802**. A ferrite additive **1843** in flexible housing **1802** may increase the efficiency of the primary antenna and/or may reduce excess external transmissions by reflecting and/or absorbing the radiofrequency signal.

In some embodiments consistent with the present disclosure, electrical communication between carrier **1201** and an electronics housing may be made through electrical contacts **1810** located on a protruding non-pouch connector **1811**, as

illustrated in FIG. **8d**. Electrical contacts **1810** may be disposed circumferentially on non-pouch connector **1811** and located at different heights. In such an embodiment, a connection portion of the electronics housing may be configured to receive electrical contacts configured in this fashion.

In many of the examples described above, external unit **120** includes an electronics housing and an adhesive carrier to which the housing may be releasably connected. The examples provided are intended to be exemplary only, and are not intended to limit the placement or location of any of the components described. Additional embodiments including the location of various components on either the housing or the carrier may be realized without departing from the scope of the invention. For example, in some embodiments, some or all of the required circuit component may be printed on the carrier. In some embodiments, the primary antenna may be contained within the housing. In some embodiments, a flexible battery, such as a paper battery, may be included on the carrier to replace or supplement a battery contained in the housing.

In some embodiments, external control unit **120** may be configured for remote monitoring and control. In such an embodiment, electronics housing **1202** may include, in addition to any or all of the elements discussed above, a communications interface **145**, and memory unit **143**. Communications interface **145** may include a transceiver, configured for both transmitting and receiving, a transmitter-receiver, a transmitter alone, and a receiver alone. Processor **144** may be configured to utilize communications interface **145** to communicate with a location remote from the control unit to transmit and/or receive information which may be retrieved from and/or stored in memory unit **143**.

Processor **144** may be configured to cause application of a control signal to primary antenna **150**. Processor **144** may further be configured to monitor a feedback signal indicative of a subject's breathing. Such a feedback signal may include a coupled feedback signal developed on the primary antenna **150** through wireless interaction with the secondary antenna **152**. Further details regarding the coupled feedback signal are provided below. Processor **144** may then store information associated with or about both the control signal and the coupled feedback signal in the memory, and may utilize the communications interface **145** to transmit the stored information to a remote location. Processor **144** may also store information about the external unit, for example, information about battery depletion and energy expenditure. Processor **144** may also be configured to transmit collected information about the control signal, the feedback signal, and/or the external unit without first putting the information into storage. In such an embodiment, processor **144** may cause transmission of collected information via the communications interface **145** as that information is received. Thus, in some embodiments, external unit **120** may not require a memory.

In some embodiments, processor **144** may be configured to monitor a feedback signal provided by alternative means, such as electromyography electrodes, thermistors, accelerometers, microphones, piezoelectric sensors, etc., as previously described. Each of these means may provide a feedback signal that may be indicative of a subject's breathing. A thermistor, for example, may provide a signal that relates to a temperature of a subject's expired air, inspired air, or a subject's skin, which may be indicative of breathing. Electromyography electrodes may provide a feedback signal indicative of breathing based on the detection of muscle contractions. An accelerometer may provide a signal indica-

tive of breathing by measuring a speed or rate at which parts of the subject's body, such as a chest or chin, moves. Microphones may be used to provide feedback signals, for example, by detecting acoustic variations coincident with a breathing pattern. Finally, piezoelectric sensors, for example, may be used to measure muscle movement.

The information associated with or about the control signal and the feedback signal may include information about a patient's therapy. Information about the control signal may include a complete history and/or any portion thereof of control signal transmissions caused by the processor. Information about the feedback signal may include a complete history and/or any portion thereof of feedback signals measured, such as a history of coupled feedback signals developed on primary antenna **150**. Information associated with the feedback signal may include information about a usage period of the control unit, energy expenditure of the control unit, tongue movement, sleep disordered breathing occurrence, e.g. the occurrence of sleep apnea, hypopnea, and/or snoring, battery depletion of the control unit, and information about tongue movement in response to the modulation signal. Together, the collected information may represent a complete history of a patient's therapy session. The control signal information and feedback signal information may be stored in a synchronized fashion, to ensure that subsequent data processing can determine which portions of each signal occurred at the same time. A few examples of information that may be contained in control signal and feedback signal information are described below. As noted above, however, the memory may store complete information about control signal transmissions and feedback signals. Thus, the storage and/or transmission of any portion of these signals or any data describing them is also contemplated.

In some embodiments, information about the control signal may include summarizing information, for example a number of times or frequency with which the control signal was utilized to induce nerve modulation. Information about the control signal may include strength, duration, and other descriptive parameters of the control signal, at both modulation and sub-modulation levels. The information transmitted and received during communication with the remote location may include information about a coupled feedback signal. Information about the feedback signal may include information indicative of a patient's tongue movement or motion and information indicative of a frequency or duration of sleep disordered breathing events. In some embodiments, the stored information may be information that combines control signal information and feedback signal information, for example, information that describes a patient response to nerve modulation signals.

The stored information may be transmitted to a location remote from control unit **120** via a communications interface **145**. Communications interface **145** may include a transceiver configured to send and receive information. The transceiver may utilize various transmission methods known in the art, for example wi-fi, Bluetooth, radio, RFID, smart chip or other near field communication device, and any other method capable of wirelessly transmitting information. Communications interface **145** or transceiver may also be configured to transmit the stored information through a wired electrical connection. The transmitted information may be received by a remote location. A remote location suitable for receipt of the transmitted information may function as a relay station, or may be a final destination. A final destination, for example, may include a centralized server location. External unit **120** may transmit the stored

information to a relay station device which may then transmit the information to another relay station device or final destination. For example, a relay station device may include a patient's mobile device, smartphone, home computer, and/or a dedicated relay unit. A dedicated relay unit may include an antenna situated beneath a patient's pillow, for example to permit the transmission of a signal across a signal in circumstances where communications interface **145** may not be powerful enough or large enough to transmit a signal more than a few inches or feet. In some embodiments, a dedicated relay unit may also include a medical device console, described in greater detail below with respect to FIG. **9**, configured to receive information transmitted by communications interface **145**. The relay station device may receive the transmitted information and may store it prior to transmitting it, via, for example, any known communication technique, to a final destination. For example, the relay station may receive information from the external unit on a nightly basis, but only establish a connection with a final destination on a weekly basis. The relay station may also perform analysis on the received information prior to establishing a connection with a final destination. In some embodiments, a relay station device may relay received information immediately as it is received, or as soon as connection with the final destination can be established.

In some embodiments, external control unit **120** may be programmable and reprogrammable. For example, as described above, a memory included with external control unit **120** may store information associated with or about the control signal and the coupled feedback signal and may include information about therapy a patient has undergone. Further, a memory included with an external control unit **120** may be a programmable and/or reprogrammable memory configured to store information associated with at least one characteristic of sleep disordered breathing exhibited by a subject. Processor **144** may utilize the information associated with at least one characteristic of sleep disordered breathing to generate a hypoglossal nerve modulation control signal based on the information. That is, processor **144** may determine modulation parameters based on information about a patient's sleep disordered breathing characteristics. In some embodiments, such information may be determined by physicians, for example through the use of sleep lab equipment such as EKGs, EEGs, EMGs, breathing monitors, blood oxygen monitors, temperature monitors, brain activity monitors, cameras, accelerometers, electromyography equipment, and any other equipment useful for monitoring the sleep of a patient, and programmed into the memory. In some embodiments, such information may be determined by processor **144** by monitoring of the control signal and the coupled feedback signal.

As described above, external control unit **120** may include components that permit the recording, storage, reception, and transmission of information about a patient's sleep breathing patterns, about any therapy administered to the patient during sleep, and about the response of a patient's sleep breathing patterns to administered therapy. Such information may be stored for later transmission, may be transmitted as it is received or shortly thereafter, may be received and stored for later use, and/or may be utilized by processor **144** as it is received or shortly thereafter. This information may be generated by processor **144** through monitoring of a control signal transmitted to an implant unit **110** and a coupled feedback signal received therefrom and/or through other means described herein for processor **144** to collect feedback, such as electromyography electrodes, piezoelec-

tric sensors, audio sensors, thermistors, and accelerometers. This information may also be generated through various equipment at the disposal of physicians in, for example, a sleep lab. This stored information may be utilized, for example by processor 144 or by software running on a standard computer, to determine parameters of a hypoglossal nerve modulation control signal specific to a certain patient, based on the collected information. In an embodiment where parameters are determined by outside of external control unit 120, such parameters may be received by communications interface 145 of external control unit 120 as described above. Some examples describing the use of these capabilities is included below.

In an embodiment for determining initial modulation parameters for a patient, the above described system may operate as follows. After undergoing a surgical procedure to receive an implant unit 110, a patient may visit a sleep lab to determine initial modulation control signal parameters, such as pulse frequency, amplitude, train length, etc. Modulation control signal parameters may include pulse train parameters, described in greater detail below with respect to FIG. 17. A physician may use an endoscope to inspect an awake patient's airway during hypoglossal nerve modulation to determine that implant unit 110 is able to effectively cause airway dilation. Then, the patient may go to sleep in the sleep lab while being monitored by the physician. The patient's sleep may be monitored through a variety of tools available in a sleep lab, such as EKGs, EEGs, EMGs, breathing monitors, blood oxygen monitors, temperature monitors, brain activity monitors, cameras, electromyography electrodes, and any other equipment useful for monitoring the sleep of a patient. The monitoring equipment may be used to determine a patient's quality of sleep and to determine the onset of sleep disordered breathing. The physician may also monitor the patient's sleep through the use of external unit 120. Through a wireless or wired communication set up through communications interface 145 with processor 144, the physician may also monitor information gathered by external unit 120, e.g. modulation and sub-modulation control signals, feedback signals, battery levels, etc. Through communications interface 145, the physician may also control the modulation and sub-modulation signals generated by processor 144.

Thus, a physician may, through information gathered by sleep lab equipment and external unit 120, monitor a patient's sleep breathing patterns, including instances of sleep disordered breathing, and, in response to the monitored information, update the programming of processor 144 to optimize the therapy delivered to the patient in order to reduce instances of sleep disordered breathing. That is, processor 144 may be programmed to use a control signal that is tailored to cause optimum modulation, based on any or all of the information collected. In embodiments involving the application of a continuous modulation pulse train, such optimization may include selecting parameters, such as the frequency, amplitude, and duration of modulation pulses. For example, a physician observing a high frequency of sleep disordered breathing occurrences may adjust the parameters of a modulation pulse train until the sleep disordered breathing occurrences are reduced in number or stop altogether. The physician, thus, may be able to program processor 144 to effectively modulate the hypoglossal nerve to stop or minimize sleep disordered breathing without stimulating any more than necessary.

In some embodiments, the modulation pulse train may not be programmed with constant parameter values, but may be programmed to change during the course of an evening, or

therapy period. Constant modulation signals, whether they are constant in amplitude, duration, and/or frequency of modulation pulses may result in diminishing sensitivity or response to modulation signals over time. For example, muscular contractions in response to a constant modulation signal may be reduced over time. Over the course of a therapy period, the muscular contractions resulting from a steady pulse train may be diminished, which may, in turn, cause an increase in sleep disordered breathing events. In order to counteract this effect, a pulse train may be dynamically modified during a therapy period via a plurality of predetermined alterations to the pulse train of a modulation control signal. For example, processor 144 may be programmed to alter at least one characteristic of the modulation pulse train, e.g., to increase, decrease, or otherwise alter the amplitude, duration and/or frequency of modulation pulses over the course of a therapy period. Any and all characteristics of a pulse train of a modulation control signal may be altered over the course of therapy period to increase modulation efficacy. As described above, physician monitored therapy periods may be utilized to determine an optimal pattern of alterations to the modulation control signal.

In embodiments involving selective modulation based on the detection of sleep disordered breathing precursors, such optimization may include selecting not only modulation parameters, which may be selected so as to vary with time over the course of a therapy period, but also feedback parameters and thresholds consistent with a sleep disordered breathing determination. For example, a physician may compare indications of tongue movement collected by external unit 120 with extrinsic indicators of sleep disordered breathing from sleep lab equipment. The physician may then correlate observed sleep disordered breathing patterns with detect tongue movement patterns, and program processor 144 to generate a modulation control signal when those tongue movement patterns are detected.

In some embodiments, the actions of the physician as described above may be performed by on a computer running software dedicated to the task. A computer system may be programmed to monitor the sleep breathing patterns of a patient and to program, reprogram, and/or update the programming of processor 144 accordingly.

The present disclosure contemplates several additional embodiments for the updating of modulation parameters. In one embodiment, a patient, utilizing the sleep disordered breathing therapy system at home, may have their equipment updated based on nightly data collection. As described above, communications interface 145 of external unit 120 may transmit information either to a relay station or directly to a final destination on a regular basis, monthly, weekly, daily, and even hourly or constantly. In some embodiments, the communications interface 145 of external unit 120 may be configured to transmit information based on certain thresholds, for example, if a number of sleep disordered breathing occurrences exceeds a predetermined number. At the final destination, which may be a remote location, e.g. a physician's office, or console device in the patient's home, the collected information may be analyzed in any of the ways described above and used to determine new modulation parameters, to be transmitted, via the communications interface 145, back to the patient's external unit 120. Thus, the patient's sleep may be monitored on a regular basis, either through automated software or with the aid of a physician, and the patient's therapy may be updated accordingly.

In some embodiments, the information may be transferred to a relay station device or to a final destination when the patient places external unit **120** in a charging device.

For example, a medical console device, illustrated in FIG. **9**, may be provided with an electrical interface **955** configured to receive therapy information from a patient's external unit **120**. Medical console device **950** may further include a data storage unit **956** for storing the therapy information and at least one processing device **957** for analyzing the therapy information and determining updated control parameters for external unit **120**. Medical console device **950** may transmit updated control parameters to communications interface **145** of external unit **120** via electrical interface **955**. Such communication may be wired, or may be wireless transmission through any known means, such as wi-fi, bluetooth, RFID, etc. The information may then be processed by the console, or transmitted to a final destination for processing. Transmission to a final destination may be accomplished, for example, via the internet, wireless connection, cellular connection, or any other suitable transmission means. The information may be used to determine updated modulation parameters for processor **144**, either by the medical console device **950** or by a different final destination. In some embodiments, external unit **120** may be disposable. In such embodiments, processor **144** may be programmed with a patient's particular therapy regime through connection, wireless or wired, to the medical console device **950** prior to therapy. In some embodiments, a medical console device may be configured to transmit modulation parameters to several disposable external units **120** at the same time. In some embodiments, external unit **120** may be recharged via electrical interface **955**, in either a wired or wireless fashion. In some embodiments, medical console device **950** may be configured for bedside use, and may include, for example, all of the functions of a standard alarm clock/radio.

In some embodiments, information collected and transmitted by external control unit **120** may be used to monitor patient compliance. For example, by monitoring information such as battery depletion, modulation frequency, and any other parameter discussed herein, a physician may be able to determine whether or not a patient is complying with a therapy regime. Physicians may use this information to follow up with patient's and alter therapy regimes if necessary. In some embodiments, information collected and transmitted by external control unit **120** may be used to monitor system efficacy. For example, it may be difficult for a patient to determine how successful therapy is, as they sleep during therapy periods. The equipment and components described herein may be used to provide information to a patient and/or their physician about the effectiveness of treatment. Such information may also be used to determine effectiveness of the implant unit **110** specifically. For example, if levels of nightly battery depletion increase without a corresponding increase in the frequency of modulation, it may be indicative of a problem with implant unit **110** or its implantation.

Implant unit **110** may additionally include a plurality of field-generating implant electrodes **158a**, **158b**. The electrodes may include any suitable shape and/or orientation on the implant unit so long as the electrodes may be configured to generate an electric field in the body of a patient. Implant electrodes **158a** and **158b** may also include any suitable conductive material (e.g., copper, silver, gold, platinum, iridium, platinum-iridium, platinum-gold, conductive polymers, etc.) or combinations of conductive (and/or noble metals) materials. In some embodiments, for example, the electrodes may include short line electrodes, circular elec-

trodes, and/or circular pairs of electrodes. As shown in FIG. **10**, electrodes **158a** and **158b** may be located on an end of a first extension **162a** of an elongate arm **162**. The electrodes, however, may be located on any portion of implant unit **110**. Additionally, implant unit **110** may include electrodes located at a plurality of locations, for example on an end of both a first extension **162a** and a second extension **162b** of elongate arm **162**, as illustrated, for example, in FIG. **11a**. Positioning electrodes on two extensions of elongate arm **162** may permit bilateral hypoglossal nerve stimulation, as discussed further below. Implant electrodes may have a thickness between about 200 nanometers and 1 millimeter. Anode and cathode electrode pairs may be spaced apart by about a distance of about 0.2 mm to 25 mm. In additional embodiments, anode and cathode electrode pairs may be spaced apart by a distance of about 1 mm to 10 mm, or between 4 mm and 7 mm. Adjacent anodes or adjacent cathodes may be spaced apart by distances as small as 0.001 mm or less, or as great as 25 mm or more. In some embodiments, adjacent anodes or adjacent cathodes may be spaced apart by a distance between about 0.2 mm and 1 mm.

FIG. **10** provides a schematic representation of an exemplary configuration of implant unit **110**. As illustrated in FIG. **10**, in one embodiment, the field-generating electrodes **158a** and **158b** may include two sets of four circular electrodes, provided on flexible carrier **161**, with one set of electrodes providing an anode and the other set of electrodes providing a cathode. Implant unit **110** may include one or more structural elements to facilitate implantation of implant unit **110** into the body of a patient. Such elements may include, for example, elongated arms, suture holes, polymeric surgical mesh, biological glue, spikes of flexible carrier protruding to anchor to the tissue, spikes of additional biocompatible material for the same purpose, etc. that facilitate alignment of implant unit **110** in a desired orientation within a patient's body and provide attachment points for securing implant unit **110** within a body. For example, in some embodiments, implant unit **110** may include an elongate arm **162** having a first extension **162a** and, optionally, a second extension **162b**. Extensions **162a** and **162b** may aid in orienting implant unit **110** with respect to a particular muscle (e.g., the genioglossus muscle), a nerve within a patient's body, or a surface within a body above a nerve. For example, first and second extensions **162a**, **162b** may be configured to enable the implant unit to conform at least partially around soft or hard tissue (e.g., nerve, bone, or muscle, etc.) beneath a patient's skin. Further, implant unit **110** may also include one or more suture holes **160** located anywhere on flexible carrier **161**. For example, in some embodiments, suture holes **160** may be placed on second extension **162b** of elongate arm **162** and/or on first extension **162a** of elongate arm **162**. Implant unit **110** may be constructed in various shapes. Additionally, or alternatively, implant unit **110** may include surgical mesh **1050** or other perforatable material, described in greater detail below with respect to FIG. **12**. In some embodiments, implant unit may appear substantially as illustrated in FIG. **10**. In other embodiments, implant unit **110** may lack illustrated structures such as second extension **162b**, or may have additional or different structures in different orientations. Additionally, implant unit **110** may be formed with a generally triangular, circular, or rectangular shape, as an alternative to the winged shape shown in FIG. **10**. In some embodiments, the shape of implant unit **110** (e.g., as shown in FIG. **10**) may facilitate orientation of implant unit **110** with respect to a particular

nerve to be modulated. Thus, other regular or irregular shapes may be adopted in order to facilitate implantation in differing parts of the body.

As illustrated in FIG. 10, secondary antenna 152 and electrodes 158a, 158b may be mounted on or integrated with flexible carrier 161. Various circuit components and connecting wires may be used to connect secondary antenna with implant electrodes 158a and 158b. To protect the antenna, electrodes, and implantable circuit components from the environment within a patient's body, implant unit 110 may include a protective coating that encapsulates implant unit 110. In some embodiments, the protective coating may be made from a flexible material to enable bending along with flexible carrier 161. The encapsulation material of the protective coating may also resist humidity penetration and protect against corrosion. In some embodiments, the protective coating may include a plurality of layers, including different materials or combinations of materials in different layers.

In some embodiments of the present disclosure, the encapsulation structure of implanted unit may include two layers. For example, a first layer may be disposed over at least a portion of the implantable circuit arranged on the substrate, and a second layer may be disposed over the first layer. In some embodiments, the first layer may be disposed directly over the implantable circuit, but in other embodiments, the first layer may be disposed over an intervening material between the first layer and the implantable circuit. In some embodiments, the first layer may provide a moisture barrier and the second layer may provide a mechanical protection (e.g., at least some protection from physical damage that may be caused by scratching, impacts, bending, etc.) for the implant unit. The terms "encapsulation" and "encapsulate" as used herein may refer to complete or partial covering of a component. In some embodiments component may refer to a substrate, implantable circuit, antenna, electrodes, any parts thereof, etc. The term "layer" as used herein may refer to a thickness of material covering a surface or forming an overlying part or segment. The layer thickness can be different from layer to layer and may depend on the covering material and the method of forming the layer. For example, a layer disposed by chemical vapor may be thinner than a layer disposed through other methods.

Other configurations may also be employed. For example, another moisture barrier may be formed over the outer mechanical protection layer. In such embodiments, a first moisture barrier layer (e.g., parylene) may be disposed over (e.g., directly over or with intervening layers) the implantable circuit, a mechanical protection layer (e.g., silicone) may be formed over the first moisture barrier, and second moisture barrier (e.g., parylene) may be disposed over the mechanical protection layer.

FIG. 11a is a perspective view of an alternate embodiment of an implant unit 110, according to an exemplary embodiment of the present disclosure. As illustrated in FIG. 11a, implant unit 110 may include a plurality of electrodes, located, for example, at the ends of first extension 162a and second extension 162b. FIG. 11a illustrates an embodiment wherein implant electrodes 158a and 158b include short line electrodes.

FIG. 11b illustrates another alternate embodiment of implant unit 810, according to an exemplary embodiment of the present disclosure. Implant unit 810 is configured such that circuitry 880 is located in a vertical arrangement with secondary antenna 852. Implant unit 810 may include first

extension 162a and second extension 162b, wherein one or both of the extensions accommodate electrodes 158a and 158b.

FIG. 12 illustrates another exemplary embodiment of encapsulated implant unit 110. Exemplary embodiments may incorporate some or all of the features illustrated in FIG. 10 as well as additional features. A protective coating of implant unit 110 may include a primary capsule 1021. Primary capsule 1021 may encapsulate the implant unit 110 and may provide mechanical protection for the implant unit 110. For example, the components of implant unit 110 may be delicate, and the need to handle the implant unit 110 prior to implantation may require additional protection for the components of implant unit 110, and primary capsule 1021 may provide such protection. Primary capsule 1021 may encapsulate all or some of the components of implant unit 110. For example, primary capsule 1021 may encapsulate antenna 152, flexible carrier 161, and implantable circuit 180. The primary capsule may leave part or all of electrodes 158a, 158b exposed enabling them to deliver energy for modulating a nerve unimpeded by material of the primary capsule. In alternative embodiments, different combinations of components may be encapsulated or exposed.

Primary capsule 1021 may be fashioned of a material and thickness such that implant unit 110 remains flexible after encapsulation. Primary capsule 1021 may include any suitable bio-compatible material, such as silicone, or polyimides, phenyltrimethoxysilane (PTMS), polymethyl methacrylate (PMMA), Parylene C, liquid polyimide, laminated polyimide, polyimide, Kapton, black epoxy, polyether ketone (PEEK), Liquid Crystal Polymer (LCP), or any other suitable biocompatible coating.

In some embodiments, all or some of the circuitry components included in implant 110 may be housed in a rigid housing, as illustrated in FIGS. 13a-b. Rigid housing 1305 may provide the components of implant 110 with additional mechanical and environmental protections. A rigid housing may protect the components of implant 110 from physical trauma during implantation or from physical trauma caused by the tissue movement at an implantation site. Rigid housing may also provide additional environmental protections from the corrosive environment within the body. Furthermore, the use of a rigid housing may simplify a process for manufacturing implant unit 110.

FIGS. 13a-b illustrates an embodiment including an implant unit 110 with a rigid housing. As shown in FIGS. 13a-b, implant unit 110 may include all of the components of implant unit 110, e.g. modulation electrodes 158a, 158b, secondary antenna 152, flexible carrier 161, extension arms 162a, 162b, as well as circuitry 180 and any other component described herein. Some, or all, of these components, e.g. circuitry 180, may be included inside rigid housing 1305.

Rigid housing 130 may be constructed, for example, of ceramic, glass, and/or titanium, and may include a ceramic clamshell. Rigid housing 130 may, for example be welded closed with a biocompatible metal such as gold or titanium, or closed with any other suitable methods. Such a housing may also include a ceramic bottom portion 1306 and a titanium or ceramic upper portion 1307. Rigid housing 1305 may include one or more conductive feedthroughs 1308 to make contact with circuitry on flexible carrier 161. Inside the housing, conductive feedthroughs 1308 may be soldered, welded, or glued to circuitry 180, or any other internal component, through traditional soldering techniques. Conductive feedthroughs 1308 may comprise gold, platinum, or any other suitable conductive material. In one embodiment,

rigid housing **1305** may include four feedthroughs **1308** comprising positive and negative connections for the modulation electrodes **158a**, **158b**, and the secondary antenna **152**. Of course, any suitable number of feedthroughs **1308** may be provided.

Rigid housing **1308** may be mounted to flexible carrier **161** through controlled collapse chip connection, or C4 manufacturing. Using this technique, external portions **1309** of each conductive feedthrough **1308**, which extend beyond the surface of rigid housing **1308**, may be aligned with solder bumps on flexible carrier **161**. Solder bumps may, in turn, be connected to the electrical traces of flexible carrier **161**. Once aligned, the solder is caused to reflow, creating an electrical connection between the electrical traces of flexible carrier **161** and the internal components of rigid housing **1305** via feedthroughs **1308**. Once the electrical connection has been made, a non-conductive, or insulative, adhesive **1310** may be used to fill the gaps between the rigid housing and the flexible carrier in and around the soldered connections. The insulative adhesive **1310** may provide both mechanical protection to ensure that rigid housing **1305** does not separate from flexible carrier **161**, as well as electrical protection to ensure that the feedthroughs **1308** do not short to each other.

Once mounted to flexible carrier **161**, rigid housing **1305** and flexible carrier **161** may be encapsulated together via a multi-layer encapsulation structure described above.

Returning now to FIG. **12**, also illustrated is encapsulated surgical mesh **1050**. Surgical mesh **1050** may provide a larger target area for surgeons to use when suturing implant unit **110** into place during implantation. The entire surgical mesh **1050** may be encapsulated by primary capsule **1021**, permitting a surgeon to pass a needle through any portion of the mesh without compromising the integrity of implant unit **110**. Surgical mesh **1050** may additionally be used to cover suture holes **160**, permitting larger suture holes **160** that may provide surgeons with a greater target area. Surgical mesh **1050** may also encourage surrounding tissue to bond with implant unit **110**. In some embodiments, a surgeon may pass a surgical suture needle through suture holes **160**, located on one extension **162a** of an elongate arm **162** of implant unit **110**, through tissue of the subject, and through surgical mesh **1050** provided on a second extension **162b** of elongate arm **162** of implant unit **110**. In this embodiment, the larger target area provided by surgical mesh **1050** may facilitate the suturing process because it may be more difficult to precisely locate a suture needle after passing it through tissue. Implantation and suturing procedures may be further facilitated through the use of a delivery tool, described in greater detail below.

Returning to FIGS. **2** and **3**, external unit **120** may be configured to communicate with implant unit **110**. For example, in some embodiments, a primary signal may be generated on primary antenna **150**, using, e.g., processor **144**, signal source **142**, and amplifier **146**. More specifically, in one embodiment, power source **140** may be configured to provide power to one or both of the processor **144** and the signal source **142**. The processor **144** may be configured to cause signal source **142** to generate a signal (e.g., an RF energy signal). Signal source **142** may be configured to output the generated signal to amplifier **146**, which may amplify the signal generated by signal source **142**. The amount of amplification and, therefore, the amplitude of the signal may be controlled, for example, by processor **144**. The amount of gain or amplification that processor **144** causes amplifier **146** to apply to the signal may depend on a variety of factors, including, but not limited to, the shape,

size, and/or configuration of primary antenna **150**, the size of the patient, the location of implant unit **110** in the patient, the shape, size, and/or configuration of secondary antenna **152**, a degree of coupling between primary antenna **150** and secondary antenna **152** (discussed further below), a desired magnitude of electric field to be generated by implant electrodes **158a**, **158b**, etc. Amplifier **146** may output the amplified signal to primary antenna **150**.

External unit **120** may communicate a primary signal on primary antenna **150** to the secondary antenna **152** of implant unit **110**. This communication may result from coupling between primary antenna **150** and secondary antenna **152**. Such coupling of the primary antenna and the secondary antenna may include any interaction between the primary antenna and the secondary antenna that causes a signal on the secondary antenna in response to a signal applied to the primary antenna. In some embodiments, coupling between the primary and secondary antennas may include capacitive coupling, inductive coupling, radiofrequency coupling, etc. and any combinations thereof.

Coupling between primary antenna **150** and secondary antenna **152** may depend on the proximity of the primary antenna relative to the secondary antenna. That is, in some embodiments, an efficiency or degree of coupling between primary antenna **150** and secondary antenna **152** may depend on the proximity of the primary antenna to the secondary antenna. The proximity of the primary and secondary antennas may be expressed in terms of a coaxial offset (e.g., a distance between the primary and secondary antennas when central axes of the primary and secondary antennas are co-aligned), a lateral offset (e.g., a distance between a central axis of the primary antenna and a central axis of the secondary antenna), and/or an angular offset (e.g., an angular difference between the central axes of the primary and secondary antennas). In some embodiments, a theoretical maximum efficiency of coupling may exist between primary antenna **150** and secondary antenna **152** when both the coaxial offset, the lateral offset, and the angular offset are zero. Increasing any of the coaxial offset, the lateral offset, and the angular offset may have the effect of reducing the efficiency or degree of coupling between primary antenna **150** and secondary antenna **152**.

As a result of coupling between primary antenna **150** and secondary antenna **152**, a secondary signal may arise on secondary antenna **152** when the primary signal is present on the primary antenna **150**. Such coupling may include inductive/magnetic coupling, RF coupling/transmission, capacitive coupling, or any other mechanism where a secondary signal may be generated on secondary antenna **152** in response to a primary signal generated on primary antenna **150**. Coupling may refer to any interaction between the primary and secondary antennas. In addition to the coupling between primary antenna **150** and secondary antenna **152**, circuit components associated with implant unit **110** may also affect the secondary signal on secondary antenna **152**. Thus, the secondary signal on secondary antenna **152** may refer to any and all signals and signal components present on secondary antenna **152** regardless of the source.

While the presence of a primary signal on primary antenna **150** may cause or induce a secondary signal on secondary antenna **152**, the coupling between the two antennas may also lead to a coupled signal or signal components on the primary antenna **150** as a result of the secondary signal present on secondary antenna **152**. A signal on primary antenna **150** induced by a secondary signal on secondary antenna **152** may be referred to as a primary coupled signal component. The primary signal may refer to any and

all signals or signal components present on primary antenna 150, regardless of source, and the primary coupled signal component may refer to any signal or signal component arising on the primary antenna as a result of coupling with signals present on secondary antenna 152. Thus, in some embodiments, the primary coupled signal component may contribute to the primary signal on primary antenna 150.

Implant unit 110 may be configured to respond to external unit 120. For example, in some embodiments, a primary signal generated on primary coil 150 may cause a secondary signal on secondary antenna 152, which in turn, may cause one or more responses by implant unit 110. In some embodiments, the response of implant unit 110 may include the generation of an electric field between implant electrodes 158a and 158b.

FIG. 14 illustrates circuitry 170 that may be included in external unit 120 and circuitry 180 that may be included in implant unit 110. Additional, different, or fewer circuit components may be included in either or both of circuitry 170 and circuitry 180. As shown in FIG. 14, secondary antenna 152 may be arranged in electrical communication with implant electrodes 158a, 158b. In some embodiments, circuitry connecting secondary antenna 152 with implant electrodes 158a and 158b may cause a voltage potential across implant electrodes 158a and 158b in the presence of a secondary signal on secondary antenna 152. This voltage potential may be referred to as a field inducing signal, as this voltage potential may generate an electric field between implant electrodes 158a and 158b. More broadly, the field inducing signal may include any signal (e.g., voltage potential) applied to electrodes associated with the implant unit that may result in an electric field being generated between the electrodes.

The field inducing signal may be generated as a result of conditioning of the secondary signal by circuitry 180. As shown in FIG. 6, circuitry 170 of external unit 120 may be configured to generate an AC primary signal on primary antenna 150 that may cause an AC secondary signal on secondary antenna 152. In certain embodiments, however, it may be advantageous (e.g., in order to generate a unidirectional electric field for modulation of a nerve) to provide a DC field inducing signal at implant electrodes 158a and 158b. To convert the AC secondary signal on secondary antenna 152 to a DC field inducing signal, circuitry 180 in implant unit 110 may include an AC-DC converter. The AC to DC converter may include any suitable converter known to those skilled in the art. For example, in some embodiments the AC-DC converter may include rectification circuit components including, for example, diode 156 and appropriate capacitors and resistors. In alternative embodiments, implant unit 110 may include an AC-AC converter, or no converter, in order to provide an AC field inducing signal at implant electrodes 158a and 158b.

As noted above, the field inducing signal may be configured to generate an electric field between implant electrodes 158a and 158b. In some instances, the magnitude and/or duration of the generated electric field resulting from the field inducing signal may be sufficient to modulate one or more nerves in the vicinity of electrodes 158a and 158b. In such cases, the field inducing signal may be referred to as a modulation signal. In other instances, the magnitude and/or duration of the field inducing signal may generate an electric field that does not result in nerve modulation. In such cases, the field inducing signal may be referred to as a sub-modulation signal.

Various types of field inducing signals may constitute modulation signals. For example, in some embodiments, a

modulation signal may include a moderate amplitude and moderate duration, while in other embodiments, a modulation signal may include a higher amplitude and a shorter duration. Various amplitudes and/or durations of field-inducing signals across electrodes 158a, 158b may result in modulation signals, and whether a field-inducing signal rises to the level of a modulation signal can depend on many factors (e.g., distance from a particular nerve to be stimulated; whether the nerve is branched; orientation of the induced electric field with respect to the nerve; type of tissue present between the electrodes and the nerve; etc.).

In some embodiments, the electrodes 158a and 158b may generate an electric field configured to penetrate intervening tissue 111 between the electrodes and one or more nerves.

The intervening tissue 111 may include muscle tissue, bone, connective tissue, adipose tissue, organ tissue, or any combination thereof. For subjects suffering with obstructive sleep apnea, for instance, the intervening tissue may include the genioglossus muscle.

The generation of electric fields configured to penetrate intervening tissue is now discussed with respect to FIGS. 15a, 15b, 15c, and 16. In response to a field inducing signal, implant electrodes 158a and 158b may be configured to generate an electric field with field lines extending generally in the longitudinal direction of one or more nerves to be modulated. In some embodiments, implant electrodes 158a and 158b may be spaced apart from one another along the longitudinal direction of a nerve to facilitate generation of such an electric field. The electric field may also be configured to extend in a direction substantially parallel to a longitudinal direction of at least some portion of the nerve to be modulated. For example, a substantially parallel field may include field lines that extend more in a longitudinal direction than a transverse direction compared to the nerve. Orienting the electric field in this way may facilitate electrical current flow through a nerve or tissue, thereby increasing the likelihood of eliciting an action potential to induce modulation.

FIG. 15a illustrates a pair of electrodes 158a, 158b spaced apart from one another along the longitudinal direction of nerve 210 to facilitate generation of an electric field having field lines 220 substantially parallel to the longitudinal direction of nerve 210. In FIG. 15a, modulation electrodes 158a, 158b are illustrated as line electrodes, although the generation of substantially parallel electric fields may be accomplished through the use of other types of electrodes, for example, a series of point electrodes. Utilizing an electric field having field lines 220 extending in a longitudinal direction of nerve 210 may serve to reduce the amount of energy required to achieve neural modulation.

Naturally functioning neurons function by transmitting action potentials along their length. Structurally, neurons include multiple ion channels along their length that serve to maintain a voltage potential gradient across a plasma membrane between the interior and exterior of the neuron. Ion channels operate by maintaining an appropriate balance between positively charged sodium ions on one side of the plasma membrane and negatively charged potassium ions on the other side of the plasma membrane. A sufficiently high voltage potential difference created near an ion channel may exceed a membrane threshold potential of the ion channel. The ion channel may then be induced to activate, pumping the sodium and potassium ions across the plasma membrane to switch places in the vicinity of the activated ion channel. This, in turn, further alters the potential difference in the vicinity of the ion channel, which may serve to activate a neighboring ion channel. The cascading activation of adja-

cent ion channels may serve to propagate an action potential along the length of the neuron. Further, the activation of an ion channel in an individual neuron may induce the activation of ion channels in neighboring neurons that, bundled together, form nerve tissue. The activation of a single ion channel in a single neuron, however, may not be sufficient to induce the cascading activation of neighboring ion channels necessary to permit the propagation of an action potential. Thus, the more ion channels in a locality that may be recruited by an initial potential difference, caused through natural means such as the action of nerve endings or through artificial means, such as the application of electric fields, the more likely the propagation of an action potential may be. The process of artificially inducing the propagation of action potentials along the length of a nerve may be referred to as stimulation, or up modulation.

Neurons may also be prevented from functioning naturally through constant or substantially constant application of a voltage potential difference. After activation, each ion channel experiences a refractory period, during which it “resets” the sodium and potassium concentrations across the plasma membrane back to an initial state. Resetting the sodium and potassium concentrations causes the membrane threshold potential to return to an initial state. Until the ion channel restores an appropriate concentration of sodium and potassium across the plasma membrane, the membrane threshold potential will remain elevated, thus requiring a higher voltage potential to cause activation of the ion channel. If the membrane threshold potential is maintained at a high enough level, action potentials propagated by neighboring ion channels may not create a large enough voltage potential difference to surpass the membrane threshold potential and activate the ion channel. Thus, by maintaining a sufficient voltage potential difference in the vicinity of a particular ion channel, that ion channel may serve to block further signal transmission. The membrane threshold potential may also be raised without eliciting an initial activation of the ion channel. If an ion channel (or a plurality of ion channels) are subjected to an elevated voltage potential difference that is not high enough to surpass the membrane threshold potential, it may serve to raise the membrane threshold potential over time, thus having a similar effect to an ion channel that has not been permitted to properly restore ion concentrations. Thus, an ion channel may be recruited as a block without actually causing an initial action potential to propagate. This method may be valuable, for example, in pain management, where the propagation of pain signals is undesired. As described above with respect to stimulation, the larger the number of ion channels in a locality that may be recruited to serve as blocks, the more likely the chance that an action potential propagating along the length of the nerve will be blocked by the recruited ion channels, rather than traveling through neighboring, unblocked channels.

The number of ion channels recruited by a voltage potential difference may be increased in at least two ways. First, more ion channels may be recruited by utilizing a larger voltage potential difference in a local area. Second, more ion channels may be recruited by expanding the area affected by the voltage potential difference.

Returning to FIG. 15a, it can be seen that, due to the electric field lines 220 running in a direction substantially parallel to the longitudinal direction of the nerve 210, a large portion of nerve 210 may encounter the field. Thus, more ion channels from the neurons that make up nerve 210 may be recruited without using a larger voltage potential difference. In this way, modulation of nerve 210 may be achieved with

a lower current and less power usage. FIG. 15b illustrates an embodiment wherein electrodes 158a and 158b are still spaced apart from one another in a longitudinal direction of at least a portion of nerve 210. A significant portion of nerve 210 remains inside of the electric field. FIG. 15c illustrates a situation wherein electrodes 158a and 158b are spaced apart from one another in a transverse direction of nerve 210. In this illustration, it can be seen that a significantly smaller portion of nerve 210 will be affected by electric field lines 220.

FIG. 16 illustrates potential effects of electrode configuration on the shape of a generated electric field. The top row of electrode configurations, e.g. A, B, and C, illustrates the effects on the electric field shape when a distance between electrodes of a constant size is adjusted. The bottom row of electrode configurations, e.g. D, E, and F illustrates the effects on the electric field shape when the size of electrodes of constant distance is adjusted.

In embodiments consistent with the present disclosure, modulation electrodes 158a, 158b may be arranged on the surface of a muscle or other tissue, in order to modulate a nerve embedded within the muscle or other tissue. Thus, tissue may be interposed between modulation electrodes 158a, 158b and a nerve to be modulated. Modulation electrodes 158a, 158b may be spaced away from a nerve to be modulated. The structure and configuration of modulation electrodes 158a, 158b may play an important role in determining whether modulation of a nerve, which is spaced a certain distance away from the electrodes, may be achieved.

Electrode configurations A, B, and C show that when modulation electrodes 158a, 158b of a constant size are moved further apart, the depth of the electric field facilitated by the electrodes increases. The strength of the electric field for a given configuration may vary significantly depending on a location within the field. If a constant level of current is passed between modulation electrodes 158a and 158b, however, the larger field area of configuration C may exhibit a lower overall current density than the smaller field area of configuration A. A lower current density, in turn, implies a lower voltage potential difference between two points spaced equidistant from each other in the field facilitated by configuration C relative to that of the field facilitated by configuration A. Thus, while moving modulation electrodes 158a and 158b farther from each other increases the depth of the field, it also decreases the strength of the field. In order to modulate a nerve spaced away from modulation electrodes 158a, 158b, a distance between the electrodes may be selected in order to facilitate an electric field of strength sufficient to surpass a membrane threshold potential of the nerve (and thereby modulate it) at the depth of the nerve. If modulation electrodes 158a, 158b are too close together, the electric field may not extend deep enough into the tissue in order to modulate a nerve located therein. If modulation electrodes 158a, 158b are too far apart, the electric field may be too weak to modulate the nerve at the appropriate depth.

Appropriate distances between modulation electrodes 158a, 158b, may depend on an implant location and a nerve to be stimulated. For example, modulation point 901 is located at the same depth equidistant from the centers of modulation electrodes 158a, 158b in each of configurations A, B, and C. The figures illustrate that, in this example, configuration B is most likely to achieve the highest possible current density, and therefore voltage potential, at modulation point 901. The field of configuration A may not extend deeply enough, and the field of configuration C may be too weak at that depth.

In some embodiments, modulation electrodes **158a**, **158b** may be spaced apart by about a distance of about 0.2 mm to 25 mm. In additional embodiments, modulation electrodes **158a**, **158b** may be spaced apart by a distance of about 1 mm to 10 mm, or between 4 mm and 7 mm. In other embodiments modulation electrodes **158a**, **158b** may be spaced apart by between approximately 6 mm and 7 mm.

Electrode configurations D, E, and F show that when modulation electrodes **158a**, **158b** of a constant distance are changed in size, the shape of the electric field facilitated by the electrodes changes. If a constant level of current is passed between when modulation electrodes **158a** and **158b**, the smaller electrodes of configuration D may facilitate a deeper field than that of configurations E and F, although the effect is less significant relative to changes in distance between the electrodes. As noted above, the facilitated electric fields are not of uniform strength throughout, and thus the voltage potential at seemingly similar locations within each of the electric fields of configurations D, E, and, F may vary considerably. Appropriate sizes of modulation electrodes **158a**, **158b**, may therefore depend on an implant location and a nerve to be stimulated.

In some embodiments, modulation electrodes **158a**, **158b** may have a surface area between approximately 0.01 mm² and 80 mm². In additional embodiments, modulation electrodes **158a**, **158b** may have a surface area between approximately 0.1 mm² and 4 mm². In other embodiments modulation electrodes **158a**, **158b** may have a surface area of between approximately 0.25 mm² and 0.35 mm².

In some embodiments, modulation electrodes **158a**, **158b** may be arranged such that the electrodes are exposed on a single side of carrier **161**. In such an embodiment, an electric field is generated only on the side of carrier **161** with exposed electrical contacts. Such a configuration may serve to reduce the amount of energy required to achieve neural modulation, because the entire electric field is generated on the same side of the carrier as the nerve, and little or no current is wasted traveling through tissue away from the nerve to be modulated. Such a configuration may also serve to make the modulation more selective. That is, by generating an electric field on the side of the carrier where there is a nerve to be modulated, nerves located in other areas of tissue (e.g. on the other side of the carrier from the nerve to be modulated), may avoid being accidentally modulated.

As discussed above, the utilization of electric fields having electrical field lines extending in a direction substantially parallel to the longitudinal direction of a nerve to be modulated may serve to lower the power requirements of modulation. This reduction in power requirements may permit the modulation of a nerve using less than 1.6 mA of current, less than 1.4 mA of current, less than 1.2 mA of current, less than 1 mA of current, less than 0.8 mA of current, less than 0.6 mA of current, less than 0.4 mA of current, and even less than 0.2 mA of current passed between modulation electrodes **158a**, **158b**.

Reducing the current flow required may have additional effects on the configuration of implant unit **110** and external unit **120**. For example, the reduced current requirement may enable implant unit **110** to modulate a nerve without a requirement for a power storage unit, such as a battery or capacitor, to be implanted in conjunction with implant unit **110**. For example, implant unit **110** may be capable of modulating a nerve using only the energy received via secondary antenna **152**. Implant unit **110** may be configured to serve as a pass through that directs substantially all received energy to modulation electrodes **158a** and **158b** for nerve modulation. Substantially all received energy may

refer to that portion of energy that is not dissipated or otherwise lost to the internal components of implant unit **110**. Finally, the reduction in required current may also serve to reduce the amount of energy required by external unit **120**. External unit **120** may be configured to operate successfully for an entire treatment session lasting from one to ten hours by utilizing a battery having a capacity of less than 240 mAh, less than 120 mAh, and even less than 60 mAh.

As discussed above, utilization of parallel fields may enable implant unit **110** to modulate nerves in a non-contacting fashion. Contactless neuromodulation may increase the efficacy of an implanted implant unit **110** over time compared to modulation techniques requiring contact with a nerve or muscle to be modulated. Over time, implantable devices may migrate within the body. Thus, an implantable device requiring nerve contact to initiate neural modulation may lose efficacy as the device moves within the body and loses contact with the nerve to be modulated. In contrast, implant unit **110**, utilizing contactless modulation, may still effectively modulate a nerve even if it moves toward, away, or to another location relative to an initial implant location. Additionally, tissue growth and/or fibrosis may develop around an implantable device. This growth may serve to lessen or even eliminate the contact between a device designed for contact modulation and a nerve to be modulated. In contrast, implant unit **110**, utilizing contactless modulation, may continue to effectively modulate a nerve if additional tissue forms between it and a nerve to be modulated.

Another feature enabled through the use of parallel fields is the ability to modulate nerves of extremely small diameter. As the diameter of a nerve decreases, the electrical resistance of the nerve increases, causing the voltage required to induce an action potential to rise. As described above, the utilization of parallel electric fields permits the application of larger voltage potentials across nerves. This, in turn, may permit the modulation of smaller diameter nerves, requiring larger voltage potentials to induce action potentials. Nerves typically have reduced diameters at their terminal fibers, e.g. the distal ends, as they extend away from the nerve trunk. Modulating these narrower terminal fibers may permit more selective modulation. Larger nerve trunks typically carry many nerve fibers that may innervate several different muscles, and so inducing modulation of a nerve trunk may cause to the modulation of unintended nerve fibers, and thus the innervation and contraction of unintended muscles. Selective modulation of terminal fibers may prevent such unintended muscle activity. In some embodiments, implant unit **110** may be configured to modulate nerves having diameters of less than 2 mm, less than 1 mm, less than 500 microns, less than 200 microns, less than 100 microns, less than 50 microns, and even less than 25 microns.

Whether a field inducing signal constitutes a modulation signal (resulting in an electric field that may cause nerve modulation) or a sub-modulation signal (resulting in an electric field not intended to cause nerve modulation) may ultimately be controlled by processor **144** of external unit **120**. For example, in certain situations, processor **144** may determine that nerve modulation is appropriate. Under these conditions, processor **144** may cause signal source **144** and amplifier **146** to generate a modulation control signal on primary antenna **150** (i.e., a signal having a magnitude and/or duration selected such that a resulting secondary signal on secondary antenna **152** will provide a modulation signal at implant electrodes **158a** and **158b**).

Processor **144** may be configured to limit an amount of energy transferred from external unit **120** to implant unit **110**. For example, in some embodiments, implant unit **110** may be associated with a threshold energy limit that may take into account multiple factors associated with the patient and/or the implant. For example, in some cases, certain nerves of a patient should receive no more than a predetermined maximum amount of energy to minimize the risk of damaging the nerves and/or surrounding tissue. Additionally, circuitry **180** of implant unit **110** may include components having a maximum operating voltage or power level that may contribute to a practical threshold energy limit of implant unit **110**. Processor **144** may be configured to account for such limitations when setting the magnitude and/or duration of a primary signal to be applied to primary antenna **150**.

In addition to determining an upper limit of power that may be delivered to implant unit **110**, processor **144** may also determine a lower power threshold based, at least in part, on an efficacy of the delivered power. The lower power threshold may be computed based on a minimum amount of power that enables nerve modulation (e.g., signals having power levels above the lower power threshold may constitute modulation signals while signals having power levels below the lower power threshold may constitute sub-modulation signals).

A lower power threshold may also be measured or provided in alternative ways. For example, appropriate circuitry or sensors in the implant unit **110** may measure a lower power threshold. A lower power threshold may be computed or sensed by an additional external device, and subsequently programmed into processor **144**, or programmed into implant unit **110**. Alternatively, implant unit **110** may be constructed with circuitry **180** specifically chosen to generate signals at the electrodes of at least the lower power threshold. In still another embodiment, an antenna of external unit **120** may be adjusted to accommodate or produce a signal corresponding to a specific lower power threshold. The lower power threshold may vary from patient to patient, and may take into account multiple factors, such as, for example, modulation characteristics of a particular patient's nerve fibers, a distance between implant unit **110** and external unit **120** after implantation, and the size and configuration of implant unit components (e.g., antenna and implant electrodes), etc.

Processor **144** may also be configured to cause application of sub-modulation control signals to primary antenna **150**. Such sub-modulation control signals may include an amplitude and/or duration that result in a sub-modulation signal at electrodes **158a**, **158b**. While such sub-modulation control signals may not result in nerve modulation, such sub-modulation control signals may enable feedback-based control of the nerve modulation system. That is, in some embodiments, processor **144** may be configured to cause application of a sub-modulation control signal to primary antenna **150**. This signal may induce a secondary signal on secondary antenna **152**, which, in turn, induces a primary coupled signal component on primary antenna **150**.

To analyze the primary coupled signal component induced on primary antenna **150**, external unit **120** may include a feedback circuit **148** (e.g., a signal analyzer or detector, etc.), which may be placed in direct or indirect communication with primary antenna **150** and processor **144**. Sub-modulation control signals may be applied to primary antenna **150** at any desired periodicity. In some embodiments, the sub-modulation control signals may be applied to primary antenna **150** at a rate of one every five

seconds (or longer). In other embodiments, the sub-modulation control signals may be applied more frequently (e.g., once every two seconds, once per second, once per millisecond, once per nanosecond, or multiple times per second). Further, it should be noted that feedback may also be received upon application of modulation control signals to primary antenna **150** (i.e., those that result in nerve modulation), as such modulation control signals may also result in generation of a primary coupled signal component on primary antenna **150**.

The primary coupled signal component may be fed to processor **144** by feedback circuit **148** and may be used as a basis for determining a degree of coupling between primary antenna **150** and secondary antenna **152**. The degree of coupling may enable determination of the efficacy of the energy transfer between two antennas. Processor **144** may also use the determined degree of coupling in regulating delivery of power to implant unit **110**.

Processor **144** may be configured with any suitable logic for determining how to regulate power transfer to implant unit **110** based on the determined degree of coupling. For example, where the primary coupled signal component indicates that a degree of coupling has changed from a baseline coupling level, processor **144** may determine that secondary antenna **152** has moved with respect to primary antenna **150** (either in coaxial offset, lateral offset, or angular offset, or any combination). Such movement, for example, may be associated with a movement of the implant unit **110**, and the tissue that it is associated with based on its implant location. Thus, in such situations, processor **144** may determine that modulation of a nerve in the patient's body is appropriate. More particularly, in response to an indication of a change in coupling, processor **144**, in some embodiments, may cause application of a modulation control signal to primary antenna **150** in order to generate a modulation signal at implant electrodes **158a**, **158b**, e.g., to cause modulation of a nerve of the patient.

In an embodiment for the treatment of a sleep breathing disorder, movement of an implant unit **110** may be associated with movement of the tongue, which may indicate snoring, the onset of a sleep apnea event or a sleep apnea precursor. Each of these conditions may require the stimulation of the genioglossus muscle of the patient to relieve or avert the event. Such stimulation may result in contraction of the muscle and movement of the patient's tongue away from the patient's airway.

In embodiments for the treatment of head pain, including migraines, processor **144** may be configured to generate a modulation control signal based on a signal from a user, for example, or a detected level of neural activity in a sensory neuron (e.g. the greater occipital nerve or trigeminal nerve) associated with head pain. A modulation control signal generated by the processor and applied to the primary antenna **150** may generate a modulation signal at implant electrodes **158a**, **158b**, e.g., to cause inhibition or blocking of a sensory nerve of the patient. Such inhibition or blocking may decrease or eliminate the sensation of pain for the patient.

In embodiments for the treatment of hypertension, processor **144** may be configured to generate a modulation control signal based on, for example, pre-programmed instructions and/or signals from an implant indicative of blood pressure. A modulation control signal generated by the processor and applied to the primary antenna **150** may generate a modulation signal at implant electrodes **158a**, **158b**, e.g., to cause either inhibition or stimulation of nerve of a patient, depending on the requirements. For example, a

neuromodulator placed in a carotid artery or jugular artery (i.e. in the vicinity of a carotid baroreceptor), may receive a modulation control signal tailored to induce a stimulation signal at the electrodes, thereby causing the glossopharyngeal nerve associated with the carotid baroreceptors to fire at an increased rate in order to signal the brain to lower blood pressure. Similar modulation of the glossopharyngeal nerve may be achieved with a neuromodulator implanted in a subcutaneous location in a patient's neck or behind a patient's ear. A neuromodulator placed in a renal artery may receive a modulation control signal tailored to cause an inhibiting or blocking signal at the electrodes, thereby inhibiting a signal to raise blood pressure carried from the renal nerves to the kidneys.

Modulation control signals may include stimulation control signals, and sub-modulation control signals may include sub-stimulation control signals. Stimulation control signals may have any amplitude, pulse duration, or frequency combination that results in a stimulation signal at electrodes **158a**, **158b**. In some embodiments (e.g., at a frequency of between about 6.5-13.6 MHz), stimulation control signals may include a pulse duration of greater than about 50 microseconds and/or an amplitude of approximately 0.5 amps, or between 0.1 amps and 1 amp, or between 0.05 amps and 3 amps. Sub-stimulation control signals may have a pulse duration less than about 500, or less than about 200 nanoseconds and/or an amplitude less than about 1 amp, 0.5 amps, 0.1 amps, 0.05 amps, or 0.01 amps. Of course, these values are meant to provide a general reference only, as various combinations of values higher than or lower than the exemplary guidelines provided may or may not result in nerve stimulation.

In some embodiments, stimulation control signals may include a pulse train, wherein each pulse includes a plurality of sub-pulses. FIG. 17 depicts the composition of an exemplary modulation pulse train. Such a pulse train **1010** may include a plurality of modulation pulses **1020**, wherein each modulation pulse **1020** may include a plurality of modulation sub-pulses **1030**. FIG. 10 is exemplary only, at a scale appropriate for illustration, and is not intended to encompass all of the various possible embodiments of a modulation pulse train, discussed in greater detail below. An alternating current signal (e.g., at a frequency of between about 6.5-13.6 MHz) may be used to generate a pulse train **1010**, as follows. A sub-pulse **1030** may have a pulse duration of between 50-250 microseconds, or a pulse duration of between 1 microsecond and 2 milliseconds, during which an alternating current signal is turned on. For example, a 200 microsecond sub-pulse **1030** of a 10 MHz alternating current signal will include approximately 2000 periods. Each modulation pulse **1020** may, in turn, have a pulse duration **1040** of between 100 and 500 milliseconds, during which sub-pulses **1030** occur at a frequency of between 25 and 100 Hz. Thus, a modulation pulse **1020** may include between about 2.5 and 50 modulation sub-pulses **1030**. In some embodiments, a modulation **1020** pulse may include between about 5 and 15 modulation sub-pulses **1030**. For example, a 200 millisecond modulation pulse **1020** of 50 Hz modulation sub-pulses **1030** will include approximately 10 modulation sub-pulses **1030**. Finally, in a modulation pulse train **1010**, each modulation pulse **1020** may be separated from the next by a temporal spacing **1050** of between 0.2 and 2 seconds. For example, in a pulse train **1010** of 200 millisecond pulse duration **1040** modulation pulses **1020**, each separated by a 1.3 second temporal spacing **1050** from the next, a new modulation pulse **1020** will occur every 1.5 seconds. The frequency of modulation pulses **1020** may also be timed to

in accordance with physiological events of the subject. For example, modulation pulses **1020** may occur at a frequency chosen from among any multiple of a breathing frequency, such as four, eight, or sixteen. In another example, modulation pulses **1020** may be temporally spaced so as not to permit a complete relaxation of a muscle after causing a muscular contraction. The pulse duration **1040** of modulation pulses **1020** and the temporal spacing **1050** between modulation pulses **1020** in a pulse train **1010** may be maintained for a majority of the modulation pulses **1020**, or may be varied over the course of a treatment session according to a subject's need. Such variations may also be implemented for the modulation sub-pulse duration and temporal spacing.

Pulse train **1010** depicts a primary signal pulse train, as generated by external unit **120**. In some embodiments, the primary signal may result in a secondary signal on the secondary antenna **152** of implant unit **110**. This signal may be converted to a direct current signal for delivery to modulation electrodes **158a**, **158b**. In this situation, the generation of modulation sub-pulse **1030** may result in the generation and delivery of a square wave of a similar duration as modulation sub-pulse **1030** to modulation electrodes **158a**, **158b**.

In an embodiment for the treatment of sleep disordered breathing, modulation pulses **1020** and modulation sub-pulses **1030** may include stimulation pulses and stimulation sub-pulses adapted to cause neural stimulation. A pulse train **1010** of this embodiment may be utilized, for example, to provide ongoing stimulation during a treatment session. Ongoing stimulation during a treatment session may include transmission of the pulse train for at least 70%, at least 80%, at least 90%, and at least 99% of the treatment session. In the context of sleep disordered breathing, a treatment session may be a period of time during which a subject is asleep and in need of treatment to prevent sleep disordered breathing. Such a treatment session may last anywhere from about three to ten hours. A treatment session may include as few as approximately 4,000 and as many as approximately 120,000 modulation pulses **1020**. In some embodiments, a pulse train **1010** may include at least 5,000, at least 10,000, and at least 100,000 modulation pulses **1020**. In the context of other conditions to which neural modulators of the present disclosure are applied, a treatment session may be of varying length according to the duration of the treated condition.

Processor **144** may be configured to determine a degree of coupling between primary antenna **150** and secondary antenna **152** by monitoring one or more aspects of the primary coupled signal component received through feedback circuit **148**. In some embodiments, processor **144** may determine a degree of coupling between primary antenna **150** and secondary antenna **152** by monitoring a voltage level associated with the primary coupled signal component, a current level, or any other attribute that may depend on the degree of coupling between primary antenna **150** and secondary antenna **152**. For example, in response to periodic sub-modulation signals applied to primary antenna **150**, processor **144** may determine a baseline voltage level or current level associated with the primary coupled signal component. This baseline voltage level, for example, may be associated with a range of movement of the patient's tongue when a sleep apnea event or its precursor is not occurring, e.g. during normal breathing. As the patient's tongue moves toward a position associated with a sleep apnea event or its precursor, the coaxial, lateral, or angular offset between primary antenna **150** and secondary antenna **152** may

change. As a result, the degree of coupling between primary antenna 150 and secondary antenna 152 may change, and the voltage level or current level of the primary coupled signal component on primary antenna 150 may also change. Processor 144 may be configured to recognize a sleep apnea event or its precursor when a voltage level, current level, or other electrical characteristic associated with the primary coupled signal component changes by a predetermined amount or reaches a predetermined absolute value.

FIG. 18 provides a graph that illustrates this principle in more detail. For a two-coil system where one coil receives a radio frequency (RF) drive signal, graph 200 plots a rate of change in induced current in the receiving coil as a function of coaxial distance between the coils. For various coil diameters and initial displacements, graph 200 illustrates the sensitivity of the induced current to further displacement between the coils, moving them either closer together or further apart. It also indicates that, overall, the induced current in the secondary coil will decrease as the secondary coil is moved away from the primary, drive coil, i.e. the rate of change of induced current, in mA/mm, is consistently negative. The sensitivity of the induced current to further displacement between the coils varies with distance. For example, at a separation distance of 10 mm, the rate of change in current as a function of additional displacement in a 14 mm coil is approximately -6 mA/mm. If the displacement of the coils is approximately 22 mm, the rate of change in the induced current in response to additional displacement is approximately -11 mA/mm, which corresponds to a local maximum in the rate of change of the induced current. Increasing the separation distance beyond 22 mm continues to result in a decline in the induced current in the secondary coil, but the rate of change decreases. For example, at a separation distance of about 30 mm, the 14 mm coil experiences a rate of change in the induced current in response to additional displacement of about -8 mA/mm. With this type of information, processor 144 may be able to determine a particular degree of coupling between primary antenna 150 and secondary antenna 152, at any given time, by observing the magnitude and/or rate of change in the magnitude of the current associated with the primary coupled signal component on primary antenna 150.

Processor 144 may be configured to determine a degree of coupling between primary antenna 150 and secondary antenna 152 by monitoring other aspects of the primary coupled signal component. For example, in some embodiments, a residual signal, or an echo signal, may be monitored. As shown in FIG. 14, circuitry 180 in implant unit 110 may include inductors, capacitors, and resistors, and thus may constitute an LRC circuit. As described in greater detail above, when external unit 120 transmits a modulation (or sub-modulation) control signal, a corresponding signal is developed on secondary antenna 152. The signal developed on secondary antenna 152 causes current to flow in circuitry 180 of implant unit 110, exciting the LRC circuit. When excited the LRC circuit may oscillate at its resonant frequency, related to the values of the L (inductance), R (resistance), and C (capacitance values in the circuit). When processor 144 discontinues generating the control signal, both the oscillating signal on primary antenna 150 and the oscillating signal on secondary antenna 152 may decay over a period of time as the current is dissipated. As the oscillating signal on the secondary antenna 152 decays, so too does the coupled feedback signal received by primary antenna 150. Thus, the decaying signal in circuitry 180 of implant unit 110 may be monitored by processor 144 of external unit 120. This monitoring may be further facilitated

by configuring the circuitry 170 of external unit 120 to allow the control signal generated in primary antenna 150 to dissipate faster than the signal in the implant unit 110. Monitoring the residual signal and comparing it to expected values of a residual signal may provide processor 144 with an indication of a degree of coupling between primary antenna 150 and secondary antenna 152.

Monitoring the decaying oscillating signal in the implant unit 110 may also provide processor 144 information about the performance of implant unit 110. Processor 144 may be configured to compare the parameters of the control signal with the parameters of the detected decaying implant signal. For example, an amplitude of the decaying signal is proportional to the amount of energy remaining in implant unit 110; by comparing an amount of energy transmitted in the control signal with an amount of energy remaining in the implant, processor 144 may determine a level of power consumption in the implant. Further, by comparing a level of power consumption in the implant to a detected amount of tongue movement, processor 144 may determine an efficacy level of transmitted modulation signals. Monitoring the residual, or echo signals, in implant unit 110 may permit the implementation of several different features. Thus, processor 144 may be able to determine information including power consumption in implant unit 110, current delivery to the tissue by implant unit 110, energy delivery to implant unit 110, functionality of implant unit 110, and other parameters determinable through residual signal analysis.

Processor 144 may be configured to monitor the residual implant signal in a diagnostic mode. For example, if processor 144 detects no residual signal in implant unit 110 after transmission of a control signal, it may determine that implant unit 110 is unable to receive any type of transmission, and is not functioning. In such a case, processor 144 may cause a response that includes an indication to a user that implant unit 110 is not functioning properly. Such an indication may be in the form of, e.g., an audible or visual alarm. In another potential malfunction, if processor 144 detects a residual signal in the implant that is higher than expected, it may determine that, while implant unit is receiving a transmitted control signal, the transmitted energy is not being transferred to the tissue by electrodes 158a, 158b, at an appropriate rate.

Processor 144 may also be configured to implement a treatment protocol including the application of a desired target current level to be applied by the modulation electrodes (e.g., 1 mA). Even if the modulation control signal delivers a signal of constant amplitude, the delivered current may not remain stable. The coupled feedback signal detected by primary antenna 150 may be used as the basis for feedback control of the implant unit to ensure that the implant delivers a stable 1 mA current during each application of a modulation control signal. Processor 144, by analyzing the residual signal in the implant, may determine an amount of current delivered during the application of a modulation control signal. Processor 144 may then increase or decrease the amplitude of the modulation control signal based on the determined information about the delivered current. Thus, the modulation control signal applied to primary antenna 150 may be adjusted until the observed amplitude of the echo signal indicates that the target current level has been achieved.

In some embodiments, processor 144 may be configured to alter a treatment protocol based on detected efficacy during a therapy period. As described above, processor 144 may be configured, through residual signal analysis, to determine the amount of current, power, or energy delivered

to the tissue through electrodes **158a**, **158b**. Processor **144** may be configured to correlate the detected amount of tongue movement as a result of a modulation control signal with the amount of power ultimately delivered to the tissue. Thus, rather than comparing the effects of signal transmission with the amount of power or energy transmitted (which processor **144** may also be configured to do), processor **144** may compare the effects of signal transmission with the amount of power delivered. By comparing modulating effects with power delivered, processor **144** may be able to more accurately optimize a modulation signal.

The residual signal feedback methods discussed above may be applied to any of several other embodiments of the disclosure as appropriate. For example, information gathered through residual signal feedback analysis may be included in the information stored in memory unit **143** and transmitted to a relay or final destination via communications interface **145** of external unit **120**. In another example, the above described residual signal feedback analysis may be incorporated into methods detecting tongue movement and tongue vibration.

In some embodiments, an initially detected coupling degree may establish a baseline range when the patient attaches external unit **120** to the skin. Presumably, while the patient is awake, the tongue is not blocking the patient's airway and moves with the patients breathing in a natural range, where coupling between primary antenna **150** and secondary antenna **152** may be within a baseline range. A baseline coupling range may encompass a maximum coupling between primary antenna **150** and secondary antenna **152**. A baseline coupling range may also encompass a range that does not include a maximum coupling level between primary antenna **150** and secondary antenna **152**. Thus, the initially determined coupling may be fairly representative of a non-sleep apnea condition and may be used by processor **144** as a baseline in determining a degree of coupling between primary antenna **150** and secondary antenna **152**.

As the patient wears external unit **120**, processor **144** may periodically scan over a range of primary signal amplitudes to determine current values of coupling. If a periodic scan results in determination of a degree of coupling different from the baseline coupling, processor **144** may determine that there has been a change from the baseline initial conditions.

By periodically determining a degree of coupling value, processor **144** may be configured to determine, in situ, appropriate parameter values for the modulation control signal that will ultimately result in nerve modulation. For example, by determining the degree of coupling between primary antenna **150** and secondary antenna **152**, processor **144** may be configured to select characteristics of the modulation control signal (e.g., amplitude, pulse duration, frequency, etc.) that may provide a modulation signal at electrodes **158a**, **158b** in proportion to or otherwise related to the determined degree of coupling. In some embodiments, processor **144** may access a lookup table or other data stored in a memory correlating modulation control signal parameter values with degree of coupling. In this way, processor **144** may adjust the applied modulation control signal in response to an observed degree of coupling.

Additionally or alternatively, processor **144** may be configured to determine the degree of coupling between primary antenna **150** and secondary antenna **152** during modulation. The tongue, or other structure on or near which the implant is located, and thus implant unit **110**, may move as a result of modulation. Thus, the degree of coupling may change during modulation. Processor **144** may be configured to

determine the degree of coupling as it changes during modulation, in order to dynamically adjust characteristics of the modulation control signal according to the changing degree of coupling. This adjustment may permit processor **144** to cause implant unit **110** to provide an appropriate modulation signal at electrodes **158a**, **158b** throughout a modulation event. For example, processor **144** may alter the primary signal in accordance with the changing degree of coupling in order to maintain a constant modulation signal, or to cause the modulation signal to be reduced in a controlled manner according to patient needs.

More particularly, the response of processor **144** may be correlated to the determined degree of coupling. In situations where processor **144** determines that the degree of coupling between primary antenna **150** and secondary antenna has fallen only slightly below a predetermined coupling threshold (e.g., during snoring or during a small vibration of the tongue or other sleep apnea event precursor), processor **144** may determine that only a small response is necessary. Thus, processor **144** may select modulation control signal parameters that will result in a relatively small response (e.g., a short stimulation of a nerve, small muscle contraction, etc.). Where, however, processor **144** determines that the degree of coupling has fallen substantially below the predetermined coupling threshold (e.g., where the tongue has moved enough to cause a sleep apnea event), processor **144** may determine that a larger response is required. As a result, processor **144** may select modulation control signal parameters that will result in a larger response. In some embodiments, only enough power may be transmitted to implant unit **110** to cause the desired level of response. In other words, processor **144** may be configured to cause a metered response based on the determined degree of coupling between primary antenna **150** and secondary antenna **152**. As the determined degree of coupling decreases, processor **144** may cause transfer of power in increasing amounts. Such an approach may preserve battery life in the external unit **120**, may protect circuitry **170** and circuitry **180**, may increase effectiveness in addressing the type of detected condition (e.g., sleep apnea, snoring, tongue movement, etc.), and may be more comfortable for the patient.

In some embodiments, processor **144** may employ an iterative process in order to select modulation control signal parameters that result in a desired response level. For example, upon determining that a modulation control signal should be generated, processor **144** may cause generation of an initial modulation control signal based on a set of predetermined parameter values. If feedback from feedback circuit **148** indicates that a nerve has been modulated (e.g., if an increase in a degree of coupling is observed), then processor **144** may return to a monitoring mode by issuing sub-modulation control signals. If, on the other hand, the feedback suggests that the intended nerve modulation did not occur as a result of the intended modulation control signal or that modulation of the nerve occurred but only partially provided the desired result (e.g., movement of the tongue only partially away from the airway), processor **144** may change one or more parameter values associated with the modulation control signal (e.g., the amplitude, pulse duration, etc.).

Where no nerve modulation occurred, processor **144** may increase one or more parameters of the modulation control signal periodically until the feedback indicates that nerve modulation has occurred. Where nerve modulation occurred, but did not produce the desired result, processor **144** may re-evaluate the degree of coupling between primary antenna

150 and secondary antenna 152 and select new parameters for the modulation control signal targeted toward achieving a desired result. For example, where stimulation of a nerve causes the tongue to move only partially away from the patient's airway, additional stimulation may be desired. Because the tongue has moved away from the airway, however, implant unit 110 may be closer to external unit 120 and, therefore, the degree of coupling may have increased. As a result, to move the tongue a remaining distance to a desired location may require transfer to implant unit 110 of a smaller amount of power than what was supplied prior to the last stimulation-induced movement of the tongue. Thus, based on a newly determined degree of coupling, processor 144 can select new parameters for the stimulation control signal aimed at moving the tongue the remaining distance to the desired location.

In one mode of operation, processor 144 may be configured to sweep over a range of parameter values until nerve modulation is achieved. For example, in circumstances where an applied sub-modulation control signal results in feedback indicating that nerve modulation is appropriate, processor 144 may use the last applied sub-modulation control signal as a starting point for generation of the modulation control signal. The amplitude and/or pulse duration (or other parameters) associated with the signal applied to primary antenna 150 may be iteratively increased by predetermined amounts and at a predetermined rate until the feedback indicates that nerve modulation has occurred.

Processor 144 may be configured to determine or derive various physiologic data based on the determined degree of coupling between primary antenna 150 and secondary antenna 152. For example, in some embodiments the degree of coupling may indicate a distance between external unit 120 and implant unit 110, which processor 144 may use to determine a position of external unit 120 or a relative position of a patient's tongue. Monitoring the degree of coupling can also provide such physiologic data as whether a patient's tongue is moving or vibrating (e.g., whether the patient is snoring), by how much the tongue is moving or vibrating, the direction of motion of the tongue, the rate of motion of the tongue, etc.

In response to any of these determined physiologic data, processor 144 may regulate delivery of power to implant unit 110 based on the determined physiologic data. For example, processor 144 may select parameters for a particular modulation control signal or series of modulation control signals for addressing a specific condition relating to the determined physiologic data. If the physiologic data indicates that the tongue is vibrating, for example, processor 144 may determine that a sleep apnea event is likely to occur and may issue a response by delivering power to implant unit 110 in an amount selected to address the particular situation. If the tongue is in a position blocking the patient's airway (or partially blocking a patient's airway), but the physiologic data indicates that the tongue is moving away from the airway, processor 144 may opt to not deliver power and wait to determine if the tongue clears on its own. Alternatively, processor 144 may deliver a small amount of power to implant unit 110 (e.g., especially where a determined rate of movement indicates that the tongue is moving slowly away from the patient's airway) to encourage the tongue to continue moving away from the patient's airway or to speed its progression away from the airway.

In an embodiment for the treatment of snoring, processor 144 may be configured to determine when a subject is snoring based on a feedback signal that varies based on a breathing pattern of the subject. The feedback signal, may

include, for example, the signal induced in the primary antenna as a result of a sub-modulating signal transmitted to the secondary antenna. In an embodiment for determining whether a subject is snoring, in addition to a tongue location, tongue movement may be detected through a degree of coupling. Tongue movement, which may include tongue velocity, tongue displacement, and tongue vibration, may be indicative of snoring. Processor 144 may be configured to detect a tongue movement pattern and compare the detected movement pattern to known patterns indicative of snoring. For example, when a patient snores, the tongue may vibrate in a range between 60-100 Hz, such vibration may be detected by monitoring the coupling signal for a signal at a similar frequency. Such changes in the coupling signal may be relatively small compared to changes associated with larger movements of the tongue. Thus, snoring detection methods may be optimized to identify low amplitude signals. A low amplitude signal between 60-100 Hz may thus constitute a tongue movement pattern indicative of snoring. Additional patterns may also be detected.

Another exemplary feedback signal may include a signal obtained by external unit 120 about a snoring condition. For example, audio sensors, microphones, and/or piezoelectric devices may be incorporated into external unit 120 to gather data about a potential snoring condition. Such sensors may detect sound vibrations traveling through the air and may detect vibrations of the subject's body near the location of the external unit's contact with the skin. In still another embodiment, the feedback signal may be provided by a thermistor, or other temperature measuring device, positioned so as to measure a temperature in the airway.

In yet another embodiment, a feedback signal that varies based upon a breathing pattern of the subject may be provided by electromyography electrodes. Electromyography electrodes may detect electrical activity in muscles. Interpretation of this electrical activity may provide information about muscular contraction and muscle tone. During normal breathing, subjects typically exhibit a pattern of muscular contractions that may be associated with the normal breathing, as muscles from the face, chin, neck, ribs, and diaphragm experience contractions in sequence. Electromyography electrodes may be used to measure both the strength and the pattern of muscular contractions during breathing.

In still another embodiment, an accelerometer located on, or otherwise associated with external unit 120 may be utilized as the feedback signal to detect snoring. Located on the neck, ribs, or diaphragm, an accelerometer, by measuring external body movements, may detect a subject's breathing patterns. The accelerometer-detected breathing patterns may be analyzed to detect deviations from a normal breathing pattern, such as breathing patterns indicating heightened or otherwise altered effort.

In additional embodiments, multiple feedback signals may be utilized to detect snoring in various combinations. For example, processor 144 may be configured such that, when a tongue movement pattern indicative of snoring is detected, sensors incorporated into external unit 120 are then monitored for confirmation that a snoring condition is occurring. In another example, processor 144 may be configured to utilize sensors in external unit 120 and/or an airway temperature measuring device to detect the presence of snoring, and then to detect and record the tongue movement pattern associated with the snoring. In this way, processor 144 may be configured to learn a tongue movement pattern associated with snoring individual to a particular user.

Snoring may be correlated with heightened or otherwise altered breathing effort. Any or all of the previously described feedback methods may be used to determine or detect a heightened or otherwise altered breathing effort. Detection of such heightened or otherwise altered breathing effort may be used by processor 144 to determine that snoring is occurring.

If snoring is detected, processor 144 may be configured to cause a hypoglossal nerve modulation control signal to be applied to the primary antenna in order to wirelessly transmit the hypoglossal nerve modulation control signal to the secondary antenna of implant unit 110. Thus, in response to a detection of snoring, the processor may cause the hypoglossal nerve to be modulated. Hypoglossal nerve modulation may cause a muscular contraction of the genioglossus muscle, which may in turn alleviate the snoring condition.

The scenarios described are exemplary only. Processor 144 may be configured with software and/or logic enabling it to address a variety of different physiologic scenarios with particularity. In each case, processor 144 may be configured to use the physiologic data to determine an amount of power to be delivered to implant unit 110 in order to modulate nerves associated with the tongue with the appropriate amount of energy.

The disclosed embodiments may be used in conjunction with a method for regulating delivery of power to an implant unit. The method may include determining a degree of coupling between primary antenna 150 associated with external unit 120 and secondary antenna 152 associated with implant unit 110, implanted in the body of a patient. Determining the degree of coupling may be accomplished by processor 144 located external to implant unit 110 and that may be associated with external unit 120. Processor 144 may be configured to regulate delivery of power from the external unit to the implant unit based on the determined degree of coupling.

As previously discussed, the degree of coupling determination may enable the processor to further determine a location of the implant unit. The motion of the implant unit may correspond to motion of the body part where the implant unit may be attached. This may be considered physiologic data received by the processor. The processor may, accordingly, be configured to regulate delivery of power from the power source to the implant unit based on the physiologic data. In alternative embodiments, the degree of coupling determination may enable the processor to determine information pertaining to a condition of the implant unit. Such a condition may include location as well as information pertaining to an internal state of the implant unit. The processor may, according to the condition of the implant unit, be configured to regulate delivery of power from the power source to the implant unit based on the condition data.

In some embodiments, implant unit 110 may include a processor located on the implant. A processor located on implant unit 110 may perform all or some of the processes described with respect to the at least one processor associated with an external unit. For example, a processor associated with implant unit 110 may be configured to receive a control signal prompting the implant controller to turn on and cause a modulation signal to be applied to the implant electrodes for modulating a nerve. Such a processor may also be configured to monitor various sensors associated with the implant unit and to transmit this information back to an external unit. Power for the processor unit may be supplied by an onboard power source or received via transmissions from an external unit.

In other embodiments, implant unit 110 may be self-sufficient, including its own power source and a processor configured to operate the implant unit 110 with no external interaction. For example, with a suitable power source, the processor of implant unit 110 could be configured to monitor conditions in the body of a subject (via one or more sensors or other means), determining when those conditions warrant modulation of a nerve, and generate a signal to the electrodes to modulate a nerve. The power source could be regenerative based on movement or biological function; or the power sources could be periodically rechargeable from an external location, such as, for example, through induction.

FIG. 19 illustrates an exemplary implantation location for implant unit 110. FIG. 19 depicts an implantation location in the vicinity of a genioglossus muscle 1060 that may be accessed through derma on an underside of a subject's chin. FIG. 19 depicts hypoglossal nerve (i.e. cranial nerve XII). The hypoglossal nerve 1051, through its lateral branch 1053 and medial branch 1052, innervates the muscles of the tongue and other glossal muscles, including the genioglossus 1060, the hyoglossus, 1062, myelohyoid (not shown) and the geniohyoid 1061 muscles. The myelohyoid muscle, not pictured in FIG. 19, forms the floor of the oral cavity, and wraps around the sides of the genioglossus muscle 1060. The horizontal compartment of the genioglossus 1060 is mainly innervated by the medial terminal fibers 1054 of the medial branch 1052, which diverges from the lateral branch 1053 at terminal bifurcation 1055. The distal portion of medial branch 1052 then variegates into the medial terminal fibers 1054. Contraction of the horizontal compartment of the genioglossus muscle 1060 may serve to open or maintain a subject's airway. Contraction of other glossal muscles may assist in other functions, such as swallowing, articulation, and opening or closing the airway. Because the hypoglossal nerve 1051 innervates several glossal muscles, it may be advantageous, for OSA treatment, to confine modulation of the hypoglossal nerve 1051 to the medial branch 1052 or even the medial terminal fibers 1054 of the hypoglossal nerve 1051. In this way, the genioglossus muscle, most responsible for tongue movement and airway maintenance, may be selectively targeted for contraction inducing neuromodulation. Alternatively, the horizontal compartment of the genioglossus muscle may be selectively targeted. The medial terminal fibers 1054 may, however, be difficult to affect with neuromodulation, as they are located within the fibers of the genioglossus muscle 1061. Embodiments of the present invention facilitate modulation the medial terminal fibers 1054, as discussed further below.

In some embodiments, implant unit 110, including at least one pair of modulation electrodes, e.g. electrodes 158a, 158b, and at least one circuit may be configured for implantation through derma (i.e. skin) on an underside of a subject's chin. When implanted through derma on an underside of a subject's chin, an implant unit 110 may be located proximate to medial terminal fibers 1054 of the medial branch 1052 of a subject's hypoglossal nerve 1051. An exemplary implant location 1070 is depicted in FIG. 19.

In some embodiments, implant unit 110 may be configured such that the electrodes 158a, 158b cause modulation of at least a portion of the subject's hypoglossal nerve through application of an electric field to a section of the hypoglossal nerve 1051 distal of a terminal bifurcation 1055 to lateral and medial branches 1053, 1052 of the hypoglossal nerve 1051. In additional or alternative embodiments, implant unit 110 may be located such that an electric field extending from the modulation electrodes 158a, 158b can

modulate one or more of the medial terminal fibers **1054** of the medial branch **1052** of the hypoglossal nerve **1051**. Thus, the medial branch **1053** or the medial terminal fibers **1054** may be modulated so as to cause a contraction of the genioglossus muscle **1060**, which may be sufficient to either open or maintain a patient's airway. When implant unit **110** is located proximate to the medial terminal fibers **1054**, the electric field may be configured so as to cause substantially no modulation of the lateral branch of the subject's hypoglossal nerve **1051**. This may have the advantage of providing selective modulation targeting of the genioglossus muscle **1060**.

As noted above, it may be difficult to modulate the medial terminal fibers **1054** of the hypoglossal nerve **1051** because of their location within the genioglossus muscle **1060**. Implant unit **110** may be configured for location on a surface of the genioglossus muscle **1060**. Electrodes **158a**, **158b**, of implant unit **110** may be configured to generate a parallel electric field **1090**, sufficient to cause modulation of the medial terminal branches **1054** even when electrodes **158a**, **158b** are not in contact with the fibers of the nerve. That is, the anodes and the cathodes of the implant may be configured such that, when energized via a circuit associated with the implant **110** and electrodes **158a**, **158b**, the electric field **1090** extending between electrodes **158a**, **158b** may be in the form of a series of substantially parallel arcs extending through and into the muscle tissue on which the implant is located. A pair of parallel line electrodes or two series of circular electrodes may be suitable configurations for producing the appropriate parallel electric field lines. Thus, when suitably implanted, the electrodes of implant unit **110** may modulate a nerve in a contactless fashion, through the generation of parallel electric field lines.

Furthermore, the efficacy of modulation may be increased by an electrode configuration suitable for generating parallel electric field lines that run partially or substantially parallel to nerve fibers to be modulated. In some embodiments, the current induced by parallel electric field lines may have a greater modulation effect on a nerve fiber if the electric field lines **1090** and the nerve fibers to be modulated are partially or substantially parallel. The inset illustration of FIG. **19** depicts electrodes **158a** and **158b** generating electric field lines **1090** (shown as dashed lines) substantially parallel to medial terminal fibers **1054**.

In order to facilitate the modulation of the medial terminal fibers **1054**, implant unit **110** may be designed or configured to ensure the appropriate location of electrodes when implanted. An exemplary implantation is depicted in FIG. **20**.

For example, a flexible carrier **161** of the implant may be configured such that at least a portion of a flexible carrier **161** of the implant is located at a position between the genioglossus muscle **1060** and the geniohyoid muscle **1061**. Flexible carrier **161** may be further configured to permit at least one pair of electrodes arranged on flexible carrier **161** to lie between the genioglossus muscle **1060** and the myelohyoid muscle. Either or both of the extensions **162a** and **162b** of elongate arm **161** may be configured adapt to a contour of the genioglossus muscle. Either or both of the extensions **162a** and **162b** of elongate arm **161** may be configured to extend away from the underside of the subject's chin along a contour of the genioglossus muscle **1060**. Either or both of extension arms **162a**, **162b** may be configured to wrap around the genioglossus muscle when an antenna **152** is located between the genioglossus **1060** and geniohyoid muscle **1061**. In such a configuration, antenna

152 may be located in a plane substantially parallel with a plane defined by the underside of a subject's chin, as shown in FIG. **20**.

Flexible carrier **161** may be configured such that the at least one pair of spaced-apart electrodes can be located in a space between the subject's genioglossus muscle and an adjacent muscle. Flexible carrier **161** may be configured such that at least one pair of modulation electrodes **158a**, **158b** is configured for implantation adjacent to a horizontal compartment **1065** of the genioglossus muscle **1060**. The horizontal compartment **1065** of the genioglossus muscle **1060** is depicted in FIG. **20** and is the portion of the muscle in which the muscle fibers run in a substantially horizontal, rather than vertical, oblique, or transverse direction. At this location, the hypoglossal nerve fibers run between and in parallel to the genioglossus muscle fibers. In such a location, implant unit **110** may be configured such that the modulation electrodes generate an electric field substantially parallel to the direction of the muscle fibers, and thus, the medial terminal fibers **1054** of the hypoglossal nerve in the horizontal compartment.

As described above, implant unit **110** may include electrodes **158a**, **158b** on both extensions **162a**, **162b**, of extension arm **162**. In such a configuration, implant unit **110** may be configured for bilateral hypoglossal nerve stimulation. The above discussion has focused on a single hypoglossal nerve **1051**. The body contains a pair of hypoglossal nerves **1051**, on the left and right sides, each innervating muscles on its side. When a single hypoglossal nerve **1051** is modulated, it may cause stronger muscular contractions on the side of the body with which the modulated hypoglossal nerve is associated. This may result in asymmetrical movement of the tongue. When configured for bilateral stimulation, implant unit **110** may be able to stimulate both a left and a right hypoglossal nerve **1051**, causing more symmetric movement of the tongue and more symmetric airway dilation. As illustrated in FIGS. **11a** and **11b**, flexible carrier **161** may be sized and shaped for implantation in a vicinity of a hypoglossal nerve to be modulated such that the first pair of modulation electrodes is located to modulate a first hypoglossal nerve on a first side of the subject and the second pair of modulation electrodes is located to modulate a second hypoglossal nerve on a second side of the subject.

Bilateral stimulation protocols may include various sequences of modulation. For example, both pairs of modulation electrodes may be activated together to provide a stronger muscular response in the subject. In another example, the modulation electrodes may be activated in an alternating sequence, first one, and then the other. Such a sequence may reduce muscle or neuronal fatigue during a therapy period, and may reduce the diminishment of sensitivity that can occur in a neuron subject to a constant modulation signal. In still another example, the modulation electrodes may be activated in an alternating sequence that includes polarity reversals of the electric field. In such an embodiment, one pair of electrodes may be activated with a neuromuscular modulating electric field having a polarity configured to cause a muscular contraction, while the other pair of electrodes may be activated with a field having a reversed polarity. By alternating the polarity, it may be possible to reduce short term neuronal fatigue and possible to minimize or eliminate long term neuronal damage. In some configurations, extensions **162a** and **162b** may act as elongated arms extending from a central portion of flexible carrier **161** of implant unit **110**. The elongated arms may be configured to form an open ended curvature around a muscle, with a nerve to be stimulated, e.g. a hypoglossal

nerve, located within the curvature formed by the elongated arms. Such a configuration may also include a stiffening portion located on or within flexible carrier 161. Such a stiffening portion may comprise a material that is stiffer than a material of flexible carrier 161. The stiffening portion may be preformed in a shape to better accommodate conforming flexible carrier 161 to a muscle of the subject—such as a genioglossus muscle. The stiffening portion may also be capable of plastic deformation, so as to permit a surgeon to modify the curvature of the flexible carrier 161 prior to implantation.

The diameter of the curvature of the elongated arms may be significantly larger than the diameter of the nerve to be stimulated, for example, 2, 5, 10, 20, or more times larger. In some embodiments, a plurality of nerves to be stimulated, for example a left hypoglossal nerve and a right hypoglossal nerve, may be located within the arc of curvature formed by the elongated arms.

Other embodiments of the present disclosure will be apparent to those skilled in the art from consideration of the specification and practice of the present disclosure.

While this disclosure provides examples of the neuromodulation devices employed for the treatment of certain conditions, usage of the disclosed neuromodulation devices is not limited to the disclosed examples. The disclosure of uses of embodiments of the invention for neuromodulation are to be considered exemplary only. In its broadest sense, the invention may be used in connection with the treatment of any physiological condition through neuromodulation. Alternative embodiments will become apparent to those skilled in the art to which the present invention pertains without departing from its spirit and scope. Accordingly, the scope of the present invention is defined by the appended claims rather than the foregoing description.

What is claimed is:

1. A device, comprising:

a carrier configured for implantation in a subject in a vicinity of a hypoglossal nerve to be modulated, the carrier including a first elongated arm and a second elongated arm, each extending from a central portion of the carrier;

a first pair of modulation electrodes on the first elongated arm; and

a second pair of modulation electrodes on the second elongated arm;

wherein

the first pair of modulation electrodes is located to modulate a first hypoglossal nerve on a first side of the subject, the first pair of modulation electrodes being spaced apart from one another and configured to facilitate a first electric field in response to the electric signal,

the second pair of modulation electrodes is located to modulate a second hypoglossal nerve on a second side of the subject, the second pair of modulation electrodes being spaced apart from one another and configured to facilitate a second electric field in response to the electric signal, and

in response to a transmitted electrical signal, the first and second pairs of modulation electrodes alternate a sequence of the first and second neuromuscular modulating electric fields by alternating a polarity of the first

neuromuscular modulating electric field and the second neuromuscular modulating electric field.

2. The device of claim 1, wherein the carrier is configured for location on a genioglossus muscle of the subject.

3. The device of claim 1, wherein the first pair of modulation electrodes and the second pair of modulation electrodes modulate the first hypoglossal nerve and the second hypoglossal nerve through intervening tissue.

4. The device of claim 1, further comprising:

an antenna; and

at least one circuit electrically coupled to the first pair of modulation electrodes and the second pair of modulation electrodes,

wherein the antenna is configured to receive the transmitted electrical signal and the circuit is configured to transfer the electrical signal to the first pair of modulation electrodes and the second pair of modulation electrodes.

5. The device of claim 1, wherein the carrier is substantially flexible.

6. The device of claim 4, wherein the first electric field includes field lines extending in a longitudinal direction of the first hypoglossal nerve, and

the second electric field includes field lines extending in a longitudinal direction of the second hypoglossal nerve.

7. The device of claim 1, wherein the carrier is sized and shaped to permit the first pair of modulation electrodes and the second pair of modulation electrodes to lie between a surface of a myelohyoid muscle and a surface of a genioglossus muscle, the carrier further including a portion configured to lie between a surface of a geniohyoid muscle and the surface of the genioglossus muscle.

8. A control unit for controlling an implant unit configured for placement in a body of a subject, the implant unit having at least a first pair and a second pair of modulation electrodes and being configured for bilateral stimulation of a first and second hypoglossal nerves, the control unit comprising:

a primary antenna associated with a unit external to the subject's body; and

at least one processing device associated with the unit configured to:

cause generation of the hypoglossal nerve modulation control signal for application to the primary antenna; and

cause application of the hypoglossal nerve modulation control signal to the primary antenna in order to wirelessly transmit the hypoglossal nerve modulation control signal to a secondary antenna included on the implant unit located in the subject's body,

wherein the hypoglossal nerve modulation control signal is configured to:

cause generation of a first neuromuscular modulating electric field at the first pair of electrodes and cause generation of a second neuromuscular modulating electric field at the second pair of electrodes, and

alternate a sequence of the first and second neuromuscular modulating electric fields by alternately reversing a polarity of the first neuromuscular modulating electric field and the second neuromuscular modulating electric field.

专利名称(译)	通过双侧刺激治疗睡眠呼吸暂停		
公开(公告)号	US9463318	公开(公告)日	2016-10-11
申请号	US14/307040	申请日	2014-06-17
[标]申请(专利权)人(译)	MASHIACH ADI MASHIACH伊茨克		
申请(专利权)人(译)	MASHIACH, ADI MASHIACH, 伊茨克		
当前申请(专利权)人(译)	NYXOAH SA.		
[标]发明人	MASHIACH ADI MASHIACH ITZIK		
发明人	MASHIACH, ADI MASHIACH, ITZIK		
IPC分类号	A61N1/05 A61N2/00 A61N1/36 A61N1/372 A61F5/56 A61B5/113 A61B5/11 A61N1/378 A61N1/375 A61N2/02 A61B5/00		
CPC分类号	A61N1/36003 A61B5/0031 A61B5/11 A61B5/113 A61B5/4818 A61B5/682 A61F5/566 A61N1/0514 A61N1/0526 A61N1/0553 A61N1/3601 A61N1/3606 A61N1/3611 A61N1/36057 A61N1/36135 A61N1 /36146 A61N1/3756 A61N1/3787 A61N1/37223 A61N1/37229 A61N2/006 A61B5/4519 A61B5/6822 A61B5/6833 A61B5/6876 A61B2560/0219 A61B2562/164 A61N1/36075 A61N1/36117 A61N2/02 A61N1/3614 A61N1/0551		
助理审查员(译)	CAREY, MICHAEL		
优先权	61/541651 2011-09-30 US 61/657424 2012-06-08 US 61/836089 2013-06-17 US		
其他公开文献	US20140379049A1		
外部链接	Espacenet USPTO		

摘要(译)

提供了神经调节装置。神经调节装置可以包括被配置用于植入受试者的载体，所述载体包括第一细长臂和第二细长臂，每个细长臂从载体的中心部分延伸。该装置还可以包括布置在第一细长臂上的第一对调制电极，布置在第二细长臂上的第二对调制电极。载体的尺寸和形状可以设置成用于植入要被调制的舌下神经的附近，使得第一对调制电极位于调节对象第一侧上的第一舌下神经，并且第二对调节电极其位于在所述受试者的第二侧上调制第二舌下神经。

