



US009037271B2

(12) **United States Patent**
Kaib et al.

(10) **Patent No.:** **US 9,037,271 B2**
(45) **Date of Patent:** ***May 19, 2015**

(54) **ELECTRODE WITH REDUNDANT IMPEDANCE REDUCTION**

USPC 600/372, 388, 509; 607/142, 153, 5, 6
See application file for complete search history.

(71) Applicant: **ZOLL MEDICAL CORPORATION**,
Chelmsford, MA (US)

(56) **References Cited**

(72) Inventors: **Thomas E. Kaib**, North Huntingdon, PA (US); **Shane S. Volpe**, Saltsburg, PA (US); **Emil Oskin**, Natrona Heights, PA (US)

U.S. PATENT DOCUMENTS

3,467,863 A * 9/1969 Karsh 324/722
4,058,127 A * 11/1977 Buchalter 607/153

(Continued)

(73) Assignee: **ZOLL MEDICAL CORPORATION**,
Chelmsford, MA (US)

FOREIGN PATENT DOCUMENTS

(*) Notice: Subject to any disclaimer, the term of this patent is extended or adjusted under 35 U.S.C. 154(b) by 120 days.

EP 0295497 B1 9/1993
EP 0335356 B1 3/1996

(Continued)

This patent is subject to a terminal disclaimer.

OTHER PUBLICATIONS

(21) Appl. No.: **13/849,751**

American Journal of Respiratory and Critical Care Medicine, vol. 166, pp. 111-117 (2002), American Thoracic Society, ATS Statement: Guidelines for the Six-Minute Walk Test, available at <http://ajrccm.atsjournals.org/cgi/content/full/166/1/111>.

(22) Filed: **Mar. 25, 2013**

(65) **Prior Publication Data**

US 2013/0218252 A1 Aug. 22, 2013

(Continued)

Related U.S. Application Data

(63) Continuation of application No. 13/315,937, filed on Dec. 9, 2011, now Pat. No. 8,406,842, which is a

(Continued)

Primary Examiner — Lee S Cohen

Assistant Examiner — Erin M Cardinal

(74) *Attorney, Agent, or Firm* — Lando & Anastasi, LLP

(51) **Int. Cl.**

A61N 1/39 (2006.01)

A61N 1/37 (2006.01)

(Continued)

(57) **ABSTRACT**

An electrode assembly that includes an electrically conductive layer, a first impedance reduction system, and a second impedance reduction system. The electrically conductive layer forms an electrode portion of the electrode assembly and a first surface to be placed adjacent a person's skin. The first impedance reduction system is configured to dispense a first amount of an electrically conductive gel onto the first surface of the electrically conductive layer in response to a first activation signal. The second impedance reduction system is configured to dispense a second amount of the electrically conductive gel onto the first surface of the electrically conductive layer in response to a second activation signal.

(52) **U.S. Cl.**

CPC *A61N 1/046* (2013.01); *A61B 5/6823* (2013.01); *A61N 2001/083* (2013.01); *A61N 1/39* (2013.01);

(Continued)

(58) **Field of Classification Search**

CPC .. *A61B 5/683*; *A61B 5/04*; *A61B 2017/0003*; *A61B 2562/14*; *A61N 1/046*; *A61N 1/3918*; *A61N 1/3925*; *A61N 2001/083*

16 Claims, 4 Drawing Sheets

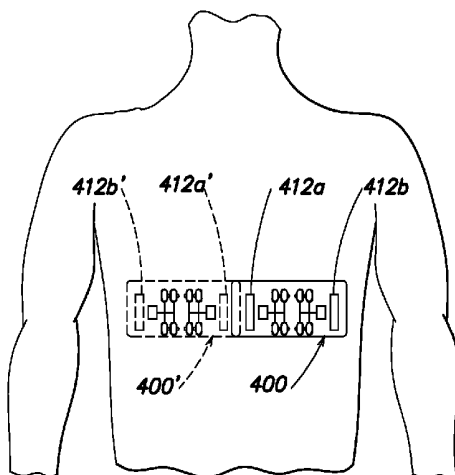

Related U.S. Application Data

- continuation of application No. PCT/US2011/063931, filed on Dec. 8, 2011.
- (60) Provisional application No. 61/421,283, filed on Dec. 9, 2010.
- (51) **Int. Cl.**
A61N 1/04 (2006.01)
A61B 5/04 (2006.01)
A61B 5/00 (2006.01)
A61N 1/08 (2006.01)
- (52) **U.S. Cl.**
 CPC *A61B 5/04* (2013.01); *A61B 5/6804* (2013.01); *A61B 2562/14* (2013.01); *A61N 1/3925* (2013.01)

2006/0036292	A1	2/2006	Smith et al.
2006/0085049	A1	4/2006	Cory et al.
2006/0270952	A1	11/2006	Freeman et al.
2007/0118056	A1	5/2007	Wang et al.
2007/0161913	A1	7/2007	Farrell et al.
2007/0169364	A1	7/2007	Townsend et al.
2007/0239220	A1	10/2007	Greenhut et al.
2007/0265671	A1	11/2007	Roberts et al.
2008/0004536	A1	1/2008	Baxi et al.
2008/0030656	A1	2/2008	Watson et al.
2008/0033495	A1	2/2008	Kumar
2008/0045815	A1	2/2008	Derchak et al.
2008/0058884	A1	3/2008	Matos
2008/0249591	A1	10/2008	Gaw et al.
2009/0073991	A1	3/2009	Landrum et al.
2009/0076336	A1	3/2009	Mazar et al.
2009/0076340	A1	3/2009	Libbus et al.
2009/0076341	A1	3/2009	James et al.
2009/0076342	A1	3/2009	Amurthur et al.
2009/0076343	A1	3/2009	James et al.
2009/0076344	A1	3/2009	Libbus et al.
2009/0076345	A1	3/2009	Manicka et al.
2009/0076346	A1	3/2009	James et al.
2009/0076348	A1	3/2009	Manicka et al.
2009/0076349	A1	3/2009	Libbus et al.
2009/0076350	A1	3/2009	Bly et al.
2009/0076363	A1	3/2009	Bly et al.
2009/0076364	A1	3/2009	Libbus et al.
2009/0076397	A1	3/2009	Libbus et al.
2009/0076405	A1	3/2009	Amurthur et al.
2009/0076410	A1	3/2009	Libbus et al.
2009/0076559	A1	3/2009	Libbus et al.
2009/0093687	A1	4/2009	Telfort et al.
2009/0138059	A1	5/2009	Ouwerkerk
2009/0234410	A1	9/2009	Libbus et al.
2009/0264792	A1	10/2009	Mazar
2009/0275848	A1	11/2009	Brockway et al.
2009/0287120	A1	11/2009	Ferren et al.
2009/0292194	A1	11/2009	Libbus et al.
2010/0056881	A1	3/2010	Libbus et al.
2010/0069735	A1	3/2010	Berkner
2010/0076513	A1	3/2010	Warren et al.
2010/0234716	A1	9/2010	Engel
2010/0298899	A1	11/2010	Donnelly et al.
2011/0028822	A1	2/2011	Beck
2011/0288604	A1	11/2011	Kaib et al.
2011/0288605	A1	11/2011	Kaib et al.
2011/0312644	A1	12/2011	Silverbrook et al.
2012/0011382	A1	1/2012	Volpe et al.
2012/0112903	A1	5/2012	Kaib et al.
2012/0146797	A1	6/2012	Oskin et al.
2012/0158075	A1	6/2012	Kaib et al.
2014/0213875	A1*	7/2014	Freeman et al. 600/386

(56) **References Cited**

U.S. PATENT DOCUMENTS

4,094,310	A	6/1978	McEachern et al.
4,464,412	A*	8/1984	Washburn 427/2.1
4,632,122	A	12/1986	Johansson et al.
4,928,690	A	5/1990	Heilman et al.
4,978,926	A	12/1990	Zerod et al.
5,062,834	A	11/1991	Gross et al.
5,078,134	A	1/1992	Heilman et al.
5,348,008	A	9/1994	Bornn et al.
5,365,932	A	11/1994	Greenhut
5,662,689	A	9/1997	Elsberry et al.
5,718,242	A	2/1998	McClure et al.
5,738,102	A	4/1998	Lemelson
5,741,306	A	4/1998	Glegyak et al.
5,758,443	A	6/1998	Pedrazzini
5,792,190	A	8/1998	Olson et al.
5,929,601	A	7/1999	Kaib et al.
5,944,669	A	8/1999	Kaib
6,016,445	A	1/2000	Baura
6,065,154	A	5/2000	Hulings et al.
6,097,987	A	8/2000	Milani
6,169,397	B1	1/2001	Steinbach et al.
6,253,099	B1	6/2001	Oskin et al.
6,280,461	B1	8/2001	Glegyak et al.
6,390,996	B1	5/2002	Halperin et al.
6,681,003	B2	1/2004	Linder et al.
6,690,969	B2	2/2004	Bystrom et al.
6,804,554	B2	10/2004	Ujhelyi et al.
6,827,695	B2	12/2004	Palazzolo et al.
6,908,437	B2	6/2005	Bardy
6,990,373	B2	1/2006	Jayne et al.
7,149,579	B1	12/2006	Koh et al.
7,220,235	B2	5/2007	Geheb et al.
7,340,296	B2	3/2008	Stahmann et al.
7,453,354	B2	11/2008	Reiter et al.
7,488,293	B2	2/2009	Marcovecchio et al.
7,831,303	B2	11/2010	Rueter et al.
7,970,451	B2	6/2011	Hassonjee et al.
7,974,689	B2	7/2011	Volpe et al.
8,121,683	B2	2/2012	Bucher et al.
8,140,154	B2	3/2012	Donnelly et al.
8,271,082	B2	9/2012	Donnelly et al.
8,406,842	B2*	3/2013	Kaib et al. 600/382
2003/0004547	A1	1/2003	Owen et al.
2003/0095648	A1	5/2003	Kaib et al.
2003/0158593	A1	8/2003	Heilman et al.
2003/0174049	A1	9/2003	Beigel et al.
2003/0195567	A1	10/2003	Jayne et al.
2003/0212311	A1	11/2003	Nova et al.
2005/0049515	A1	3/2005	Misczynski et al.
2005/0131465	A1	6/2005	Freeman et al.

FOREIGN PATENT DOCUMENTS

EP	00339471	B1	3/1997
EP	1455640	B1	1/2008
EP	1720446	B1	7/2010
JP	5115450	A	5/1993
WO	0002484	A1	1/2000
WO	2004054656	A1	7/2004

OTHER PUBLICATIONS

DeBock, et al., "Captopril treatment of chronic heart failure in the very old," J. Gerontol. (1994) 49: M148-M152.

International Search Report issued for PCT/US2011/063931 dated Aug. 23, 2012, pp. 1-3.

O'Keefe et al., "Reproducibility and responsiveness of quality of life assessment and six minute walk test in elderly heart failure patients," Heart (1998) 80: 377-382.

* cited by examiner

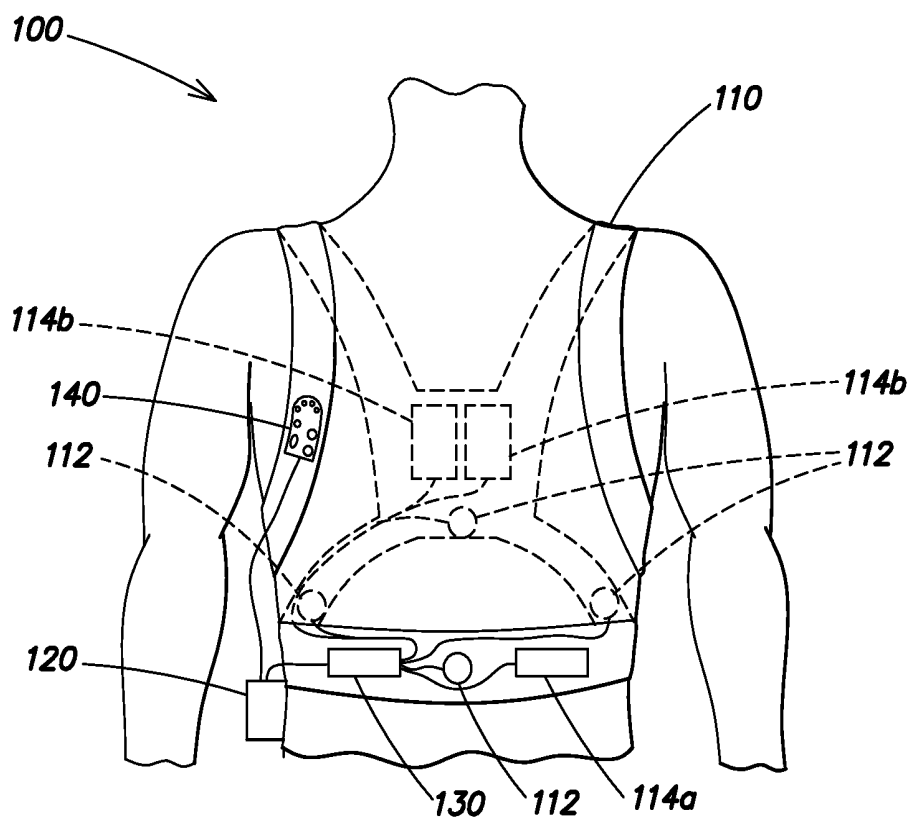

FIG. 1

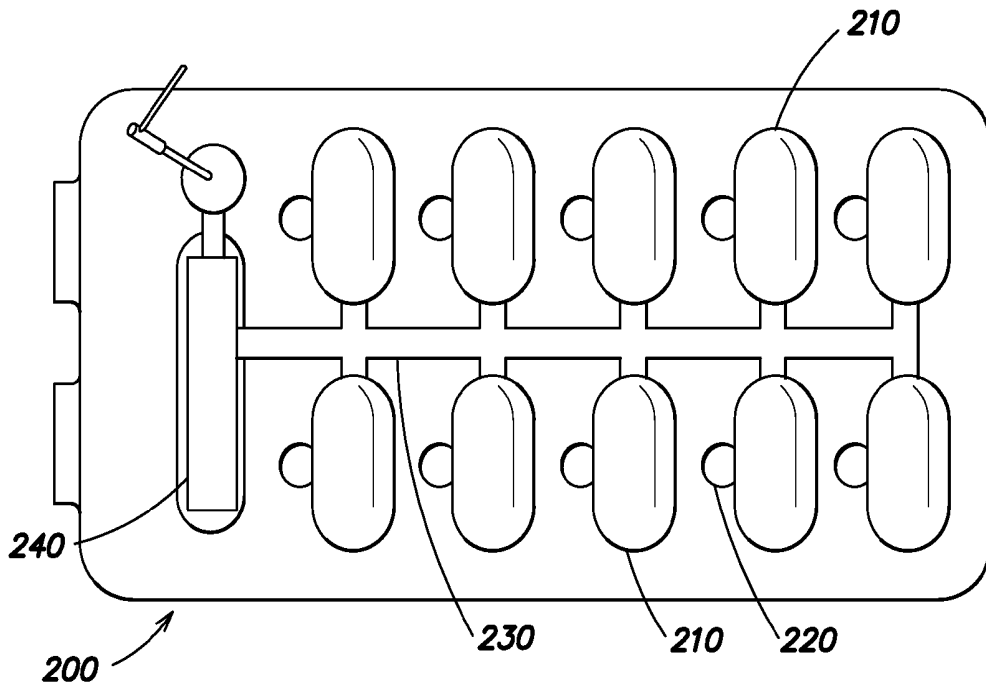

FIG. 2A

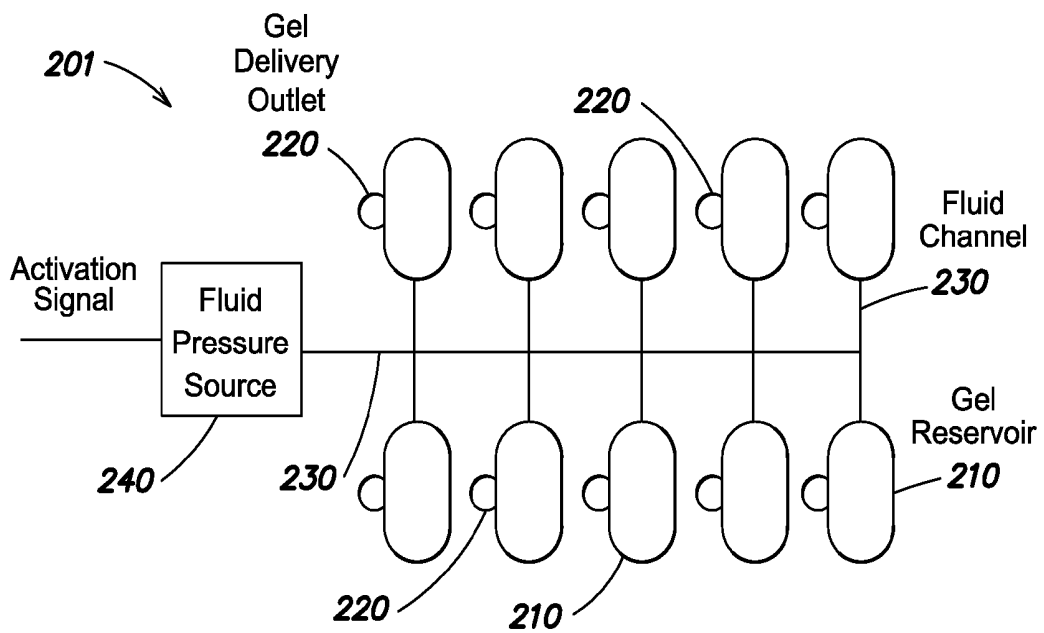

FIG. 2B

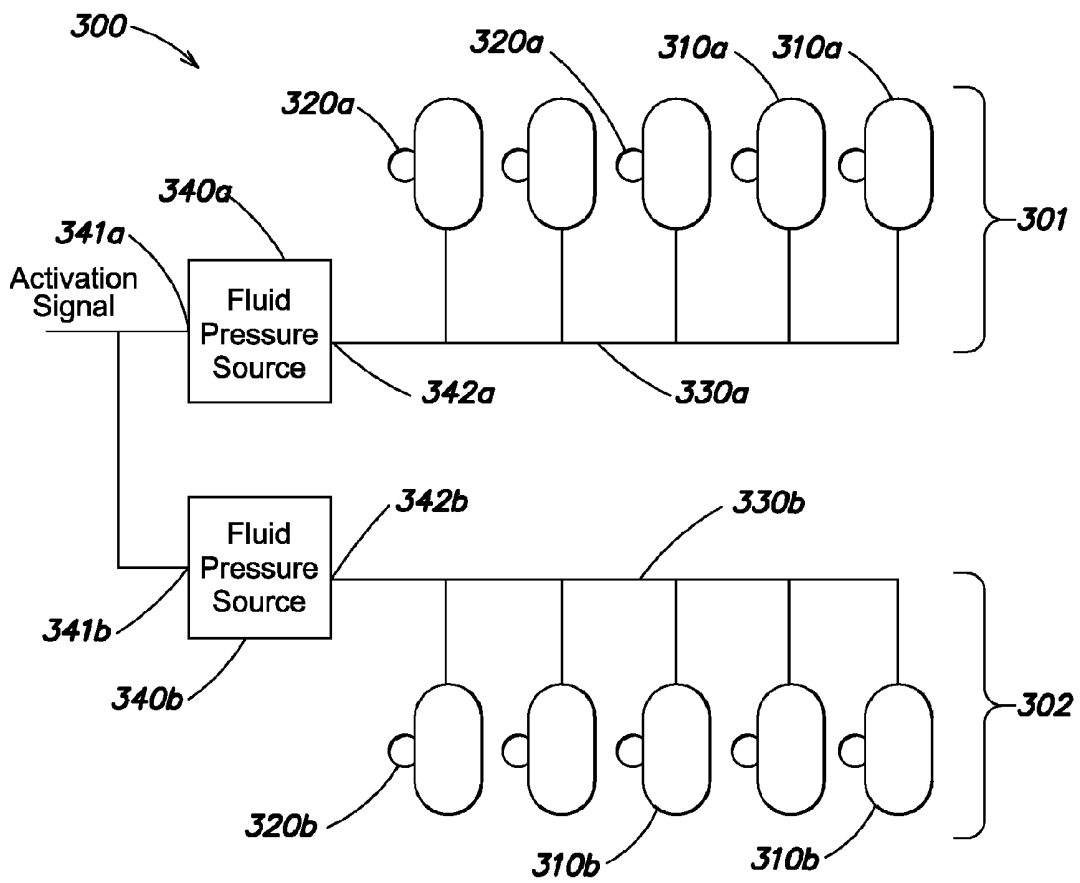

FIG. 3

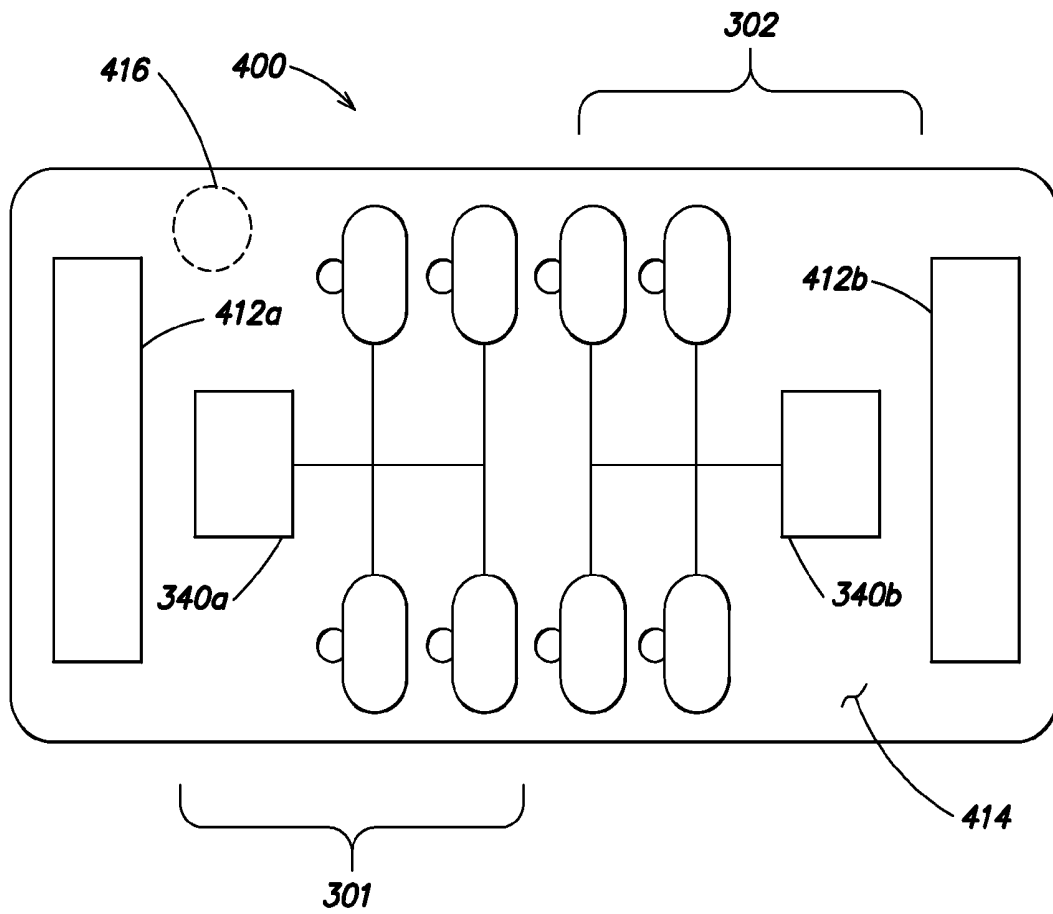

FIG. 4

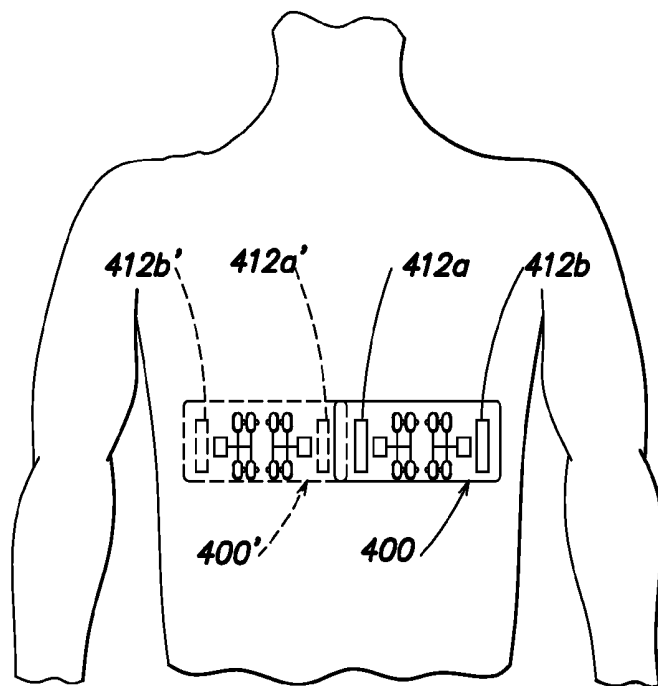

FIG. 5

ELECTRODE WITH REDUNDANT IMPEDANCE REDUCTION

CROSS REFERENCE TO RELATED APPLICATIONS

This application claims the benefit under 35 U.S.C. §120 as a continuation of U.S. application Ser. No. 13/315,937 titled "ELECTRODE WITH REDUNDANT IMPEDANCE REDUCTION" filed Dec. 9, 2011, now U.S. Pat. No. 8,406,842 B2 issued Mar. 26, 2013, which claims priority under 35 U.S.C. §120 as a continuation of International Patent Application Serial No. PCT/US2011/063931, titled "ELECTRODE WITH REDUNDANT IMPEDANCE REDUCTION" filed Dec. 8, 2011, which claims priority under 35 U.S.C. §119(e) to U.S. Provisional Application Ser. No. 61/421,283 titled "ELECTRODE WITH REDUNDANT IMPEDANCE REDUCTION" filed Dec. 9, 2010.

BACKGROUND OF THE INVENTION

1. Field of the Invention

The present invention is directed to medical electrodes, and more particularly, to a medical electrode with redundant impedance reduction systems that may be used with a wearable medical device, such as a defibrillator.

2. Discussion of Related Art

Cardiac arrest and other cardiac health ailments are a major cause of death worldwide. Various resuscitation efforts aim to maintain the body's circulatory and respiratory systems during cardiac arrest in an attempt to save the life of the victim. The sooner these resuscitation efforts begin, the better the victim's chances of survival. These efforts are expensive and have a limited success rate, and cardiac arrest, among other conditions, continues to claim the lives of victims.

To protect against cardiac arrest and other cardiac health ailments, some at-risk patients may use a wearable defibrillator, such as the LifeVest® wearable cardioverter defibrillator available from Zoll Medical Corporation of Chelmsford, Mass. To remain protected, the patient wears the device nearly continuously while going about their normal daily activities, while awake, and while asleep.

SUMMARY OF THE INVENTION

In accordance with one aspect of the present invention, an electrode assembly is provided. The electrode assembly comprises an electrically conductive layer that forms an electrode portion of the electrode assembly, a first impedance reduction system, and a second impedance reduction system. The electrically conductive layer has a first surface to be placed adjacent a person's skin. The first impedance reduction system is configured to dispense a first amount of a first electrically conductive gel onto the first surface of the electrically conductive layer in response to a first activation signal, and the second impedance reduction system is configured to dispense a second amount of a second electrically conductive gel onto the first surface of the electrically conductive layer in response to a second activation signal.

In accordance with one embodiment, the first activation signal and the second activation signal are based upon the same signal. In accordance with another embodiment, the first activation signal is distinct from the second activation signal.

In accordance with an aspect of the present invention, the second impedance reduction system is configured to dispense the second amount of the second electrically conductive gel

onto the first surface of the electrically conductive layer in response to the second activation signal and independent of whether the first impedance reduction system dispenses the first amount of the first electrically conductive gel on the first surface of the electrically conductive layer in response to the first activation signal.

In accordance with one embodiment, the first impedance reduction system is similar in construction to the second impedance reduction system.

In accordance with one embodiment, the electrically conductive layer has a plurality of apertures formed there through, the plurality of apertures including a first plurality of apertures and a second plurality of apertures. In accordance with this embodiment, the first impedance reduction system is configured to dispense the first amount of the first electrically conductive gel through the first plurality of apertures and onto the first surface of the electrically conductive layer in response to the first activation signal, and the second impedance reduction system is configured to dispense the second amount of the second electrically conductive gel through the second plurality of apertures and onto the first surface of the electrically conductive layer in response to the second activation signal. In one embodiment, the first electrically conducting gel and the second electrically conducting gel are the same type of electrically conducting gel.

In accordance with another aspect of the present invention, an electrode assembly is provided. The electrode assembly comprises an electrically conductive layer, a first plurality of gel reservoirs, a second plurality of gel reservoirs, a first fluid channel, a second fluid channel, a first fluid pressure source, and a second fluid pressure source. The electrically conductive layer has a plurality of apertures formed therein, the plurality of apertures including a first plurality of apertures and a second plurality of apertures. The first plurality of gel reservoirs each contain a first electrically conductive gel, each respective gel reservoir of the first plurality of gel reservoirs having an outlet to fluidly communicate with a respective aperture of the first plurality of apertures. The second plurality of gel reservoirs each contain a second electrically conductive gel, each respective gel reservoir of the second plurality of gel reservoirs having an outlet to fluidly communicate with a respective aperture of the second plurality of apertures. The first fluid channel is in fluid communication with each of the first plurality of gel reservoirs, and the second fluid channel is in fluid communication with each of the second plurality of gel reservoirs. The first fluid pressure source is in fluid communication with the first fluid channel and configured to receive a first activation signal and force a first fluid under pressure into the first fluid channel in response to the first activation signal, and the second fluid pressure source is in fluid communication with the second fluid channel and configured to receive a second activation signal and force a second fluid under pressure into the second fluid channel in response to the second activation signal.

In accordance with one embodiment, the outlet of each of the first plurality of gel reservoirs and the outlet of each of the second plurality of gel reservoirs is sealed by a membrane that is constructed to rupture in response to the pressure of the first fluid and the second fluid, respectively.

In accordance with one embodiment, the first activation signal and the second activation signal are based upon the same signal. In another embodiment, the first activation signal is distinct from the second activation signal.

In accordance with another aspect of the present invention, an electrode assembly is provided that comprises at least one ECG sensing electrode, a therapy electrode, a first impedance reduction system and a second impedance reduction system.

The at least one ECG sensing electrode is configured to monitor an ECG signal of a patient and the therapy electrode is configured to deliver a defibrillating shock to the patient. The first impedance reduction system is configured to reduce an impedance between the therapy electrode and the patient in response to a first activation signal, and the second impedance reduction system is configured to reduce the impedance between the therapy electrode and the patient in response to a second activation signal. In accordance with one embodiment, the at least one ECG sensing electrode is electrically insulated from the therapy electrode.

In accordance with one embodiment, the at least one ECG sensing electrode includes a plurality of ECG sensing electrodes. In accordance with a further aspect of this embodiment, each of the plurality of ECG sensing electrodes is electrically insulated from the therapy electrode.

In accordance with one embodiment, the electrode assembly further comprises at least one additional sensor configured to monitor a physiological parameter of the patient that is other than the ECG signal of the patient.

In accordance with one embodiment, the first activation signal and the second activation signal are based upon the same signal, and the first impedance reduction system is similar in construction to the second impedance reduction system.

In accordance with one embodiment, the therapy electrode includes an electrically conductive layer having a first surface to be placed adjacent a person's skin and a plurality of apertures formed through the electrically conductive layer. The plurality of apertures includes a first plurality of apertures and a second plurality of apertures. The first impedance reduction system is configured to dispense a first amount of a first electrically conductive gel through the first plurality of apertures and onto the first surface of the electrically conductive layer in response to the first activation signal, and the second impedance reduction system is configured to dispense a second amount of a second electrically conductive gel through the second plurality of apertures and onto the first surface of the electrically conductive layer in response to the second activation signal.

In accordance with another aspect of the present invention, a method of reducing impedance between an electrode and a patient's skin is provided. The method comprises acts of sending a first activation signal to a first impedance reduction system configured to dispense a first amount of a first electrically conducting gel onto a surface of the electrode that is configured to be disposed adjacent the patient's skin, and sending a second activation signal to a second impedance reduction system configured to dispense a second amount of a second electrically conducting gel onto the surface of the electrode that is configured to be disposed adjacent the patient's skin, the second impedance reduction system being distinct from the first impedance reduction system.

In accordance with one embodiment, the method further comprises an act of determining whether the first impedance reduction system dispensed the first amount of the first electrically conducting gel onto the surface of the electrode, wherein the act of sending the second activation signal to the second impedance reduction system is performed in response to a determination that the first impedance reduction system did not dispense the first amount of the first electrically conducting gel onto the surface of the electrode. In accordance with one embodiment, the act of sending the second activation signal is performed subsequent to the act of sending the first activation signal. In an alternative embodiment, the act of

sending the second activation signal is performed substantially simultaneously with the act sending the first activation signal.

Still other aspects, embodiment, and advantages of these exemplary aspects and embodiments are discussed in detail below. Moreover, it is to be understood that both the foregoing information and the following detailed description are merely illustrative examples of various aspects and embodiments of the present invention, and are intended to provide an overview or framework for understanding the nature and character of the claimed aspects and embodiments. Any embodiment disclosed herein may be combined with any other embodiment in any manner consistent with aspects of the present invention disclosed herein, and references to "an embodiment," "some embodiments," "an alternate embodiment," "various embodiments," "one embodiment," "at least one embodiment," "this and other embodiments" or the like are not necessarily mutually exclusive and are intended to indicate that a particular feature, structure, or characteristic described in connection with the embodiment may be included in at least one embodiment. The appearance of such terms herein is not necessarily all referring to the same embodiment.

BRIEF DESCRIPTION OF THE DRAWINGS

The accompanying drawings are not intended to be drawn to scale. In the drawings, each identical or nearly identical component that is illustrated in various figures is represented by a like numeral. For purposes of clarity, not every component may be labeled in every drawing. In the drawings:

FIG. 1 illustrates a wearable medical device, such as a wearable defibrillator;

FIG. 2a is a plan view of an electrode portion of a therapy electrode assembly that may be used with the wearable medical device illustrated in FIG. 1;

FIG. 2b is a functional block diagram of an impedance reduction system that may be included in the electrode portion of FIG. 2a;

FIG. 3 is a functional block diagram of a redundant impedance reduction system in accordance with an aspect of the present invention;

FIG. 4 is a schematic diagram of an electrode assembly that includes ECG sensing electrodes, a therapy electrode, and redundant impedance reduction systems in accordance with another aspect of the present invention; and

FIG. 5 illustrates the manner in which the electrode assembly of FIG. 4 may be worn on the body of a patient.

DETAILED DESCRIPTION

This invention is not limited in its application to the details of construction and the arrangement of components set forth in the following description or illustrated in the drawings. The invention is capable of other embodiments and of being practiced or of being carried out in various ways. Also, the phraseology and terminology used herein is for the purpose of description and should not be regarded as limiting. The use of "including," "comprising," "having," "containing," "involving," and variations thereof herein is meant to encompass the items listed thereafter and equivalents thereof as well as additional items.

FIG. 1 illustrates a wearable medical device, such as a LifeVest® wearable cardioverter defibrillator available from Zoll Medical Corporation of Chelmsford, Mass. As shown, the wearable medical device 100 includes a harness 110 having a pair of shoulder straps and a belt that is worn about the torso of a patient. The harness 110 is typically made from a

material, such as cotton, that is breathable, and unlikely to cause skin irritation, even when worn for prolonged periods of time. The wearable medical device **100** includes a plurality of ECG sensing electrodes **112** that are attached to the harness **110** at various positions about the patient's body and electrically coupled to a control unit **120** via a connection pod **130**. The plurality of ECG sensing electrodes **112**, which may be dry-sensing capacitance electrodes, are used by the control unit **120** to monitor the cardiac function of the patient and generally include a front/back pair of ECG sensing electrodes and a side/side pair of ECG sensing electrodes. Additional ECG sensing electrodes may be provided, and the plurality of ECG sensing electrodes **112** may be disposed at varying locations about the patient's body.

The wearable medical device **100** also includes a plurality of therapy electrodes **114** that are electrically coupled to the control unit **120** via the connection pod **130** and which are capable of delivering one or more therapeutic defibrillating shocks to the body of the patient, if it is determined that such treatment is warranted. As shown, the plurality of therapy electrodes **114** includes a first therapy electrode **114a** that is disposed on the front of the patient's torso and a second therapy electrode **114b** that is disposed on the back of the patient's torso. The second therapy electrode **114b** includes a pair of therapy electrodes that are electrically coupled together and act as the second therapy electrode **114b**. The use of two therapy electrodes **114a**, **114b** permits a biphasic shock to be delivered to the body of the patient, such that a first of the two therapy electrodes can deliver a first phase of the biphasic shock with the other therapy electrode acting as a return, and the other therapy electrode can deliver the second phase of the biphasic shock with the first therapy electrode acting as the return. The connection pod **130** electrically couples the plurality of ECG sensing electrodes **112** and the plurality of therapy electrodes **114** to the control unit **120**, and may include electronic circuitry. For example, in one implementation the connection pod **130** includes signal acquisition circuitry, such as a plurality of differential amplifiers to receive ECG signals from different ones of the plurality of ECG sensing electrodes **112** and to provide a differential ECG signal to the control unit **120** based on the difference therebetween. The connection pod **130** may also include other electronic circuitry, such as a motion sensor or accelerometer by which patient activity may be monitored.

As shown in FIG. 1, the wearable medical device **100** also includes a user interface pod **140** that is electrically coupled to the control unit **120**. The user interface pod **140** can be attached to the patient's clothing or to the harness **110**, for example, via a clip (not shown) that is attached to a portion of the interface pod **140**. Alternatively, the user interface pod **140** may simply be held in a person's hand. In some embodiments, the user interface pod **140** may communicate wirelessly with the control unit **120**, for example, using a Bluetooth®, Wireless USB, ZigBee, Wireless Ethernet, GSM, or other type of communication interface. The user interface pod **140** typically includes a number a number of buttons by which the patient, or a bystander can communicate with the control unit **120**, and a speaker by which the control unit **120** may communicate with the patient or the bystander. For example, where the control unit **120** determines that the patient is experiencing cardiac arrhythmia, the control unit **120** may issue an audible alarm via a loudspeaker (not shown) on the control unit **120** and/or the user interface pod **140** alerting the patient and any bystanders to the patient's medical condition. The control unit **120** may also instruct the patient to press and hold one or more buttons on the control unit **120** or on the user interface pod **140** to indicate that the

patient is conscious, thereby instructing the control unit **120** to withhold the delivery of one or more therapeutic defibrillating shocks. If the patient does not respond, the device may presume that the patient is unconscious, and proceed with the treatment sequence, culminating in the delivery of one or more defibrillating shocks to the body of the patient. In some embodiments, the functionality of the user interface pod **140** may be integrated into the control unit **120**.

The control unit **120** generally includes at least one processor, microprocessor, or controller, such as a processor commercially available from companies such as Texas Instruments, Intel, AMD, Sun, IBM, Motorola, Freescale and ARM Holdings. In one implementation, the at least one processor includes a power conserving processor arrangement that comprises a general purpose processor, such as an Intel® PXA270 processor and a special purpose processor, such as a Freescale™ DSP56311 Digital Signal Processor. Such a power conserving processor arrangement is described in co-pending application Ser. No. 12/833,096, entitled SYSTEM AND METHOD FOR CONSERVING POWER IN A MEDICAL DEVICE, filed Jul. 9, 2010 (hereinafter the "'096 application") which is incorporated by reference herein in its entirety. The at least one processor of the control unit **120** is configured to monitor the patient's medical condition, to perform medical data logging and storage, and to provide medical treatment to the patient in response to a detected medical condition, such as cardiac arrhythmia. Although not shown, the wearable medical device **100** may include additional sensors, other than the ECG sensing electrodes **112**, capable of monitoring the physiological condition or activity of the patient. For example, sensors capable of measuring blood pressure, heart rate, thoracic impedance, pulse oxygen level, respiration rate, heart sounds, and the activity level of the patient may also be provided.

As discussed above, to provide protection against cardiac arrest, patients that use a wearable medical device, such as a wearable defibrillator, generally wear the device nearly continuously while they are awake and while they are asleep. Because the wearable medical device is worn nearly continuously, dry electrodes are typically used for both the plurality of ECG sensing electrodes **112** and the plurality of therapy electrodes **114** for comfort and to prevent irritation of the patient's skin. Where it is determined that one or more defibrillating shocks are to be delivered to the body of the patient and the patient is non-responsive, the control unit **120** sends a signal to the plurality of therapy electrodes **114** causing them to release an impedance reducing gel prior to delivery of one or more defibrillating shocks. The impedance reducing gel reduces the impedance between the conductive surface of the therapy electrodes and the patient's skin, thereby improving the efficiency of the energy delivered to the patient and reducing the chance of damage (e.g., in the form of burning, reddening, or other types of irritation) to the patient's skin.

FIG. 2a is a plan view of an electrode portion of a therapy electrode assembly that includes an impedance reduction system and which may be used with a wearable medical device, such as the wearable defibrillator described above with respect to FIG. 1. FIG. 2b is a functional block diagram of the impedance reduction system that is included in the electrode portion of the therapy electrode assembly shown in FIG. 2a. The impedance reduction system, when activated, dispenses an impedance reducing (i.e., electrically conductive) gel onto the exposed surface of the electrode portion of the therapy electrode assembly that, in use, is placed most proximate to the patient's body. The electrode portion **200** is a multiple layer laminated structure that includes an electrically conduc-

tive layer (not visible in FIG. 2a, but disposed adjacent the bottom surface of the electrode portion 200 shown in FIG. 2a) that forms the electrode and an impedance reduction system 201. In use, the electrically conductive layer is disposed adjacent the patient's skin, although the conductive layer need not make direct contact with the patient, as portions of the harness 110 (FIG. 1) and/or portions of the patient's clothing may be present between the electrically conductive layer and the patient's skin. As shown in FIG. 2a, the impedance reduction system 201 is disposed on a side of the electrode portion 200 (i.e., the top-side shown in FIG. 2a) that is opposite the side on which the conductive layer is formed.

The impedance reduction system 201 includes a plurality of conductive gel reservoirs 210, each of which has a respective gel delivery outlet 220, that are fluidly coupled to a fluid channel 230, and a fluid pressure source 240. The fluid pressure source 240 is fluidly coupled to the fluid channel 230, and when activated by an activation signal, forces a fluid, such as Nitrogen gas, into the channel 230. The hydraulic pressure of the fluid from the activated fluid pressure source 240 in the fluid channel 230 forces the conductive gel stored in each of the plurality of gel reservoirs out of the plurality of gel delivery outlets 220 through apertures formed in the electrically conductive layer and onto the exposed surface of the electrically conductive layer that, in use, is placed most proximate to the patient's body. The apertures in the electrically conductive layer are generally aligned with the plurality of gel delivery outlets 220 so that when activated, the electrically conductive gel is dispensed onto the exposed surface of the electrode portion that is disposed most proximate to the patient's body. Further details regarding the construction of the electrode portion 200 are described in U.S. Pat. No. 5,078,134 (hereinafter "the '134 patent") which is incorporated herein by reference.

Applicants have appreciated that there may be instances where it would be desirable to have redundancy in the impedance reduction system described above. An electrode that incorporates redundant impedance reduction systems is now described with respect to FIGS. 3-5 below.

FIG. 3 is a functional block diagram of a redundant impedance reduction system that may be incorporated in an electrode assembly in accordance with an aspect of the present invention. As shown, the redundant impedance reduction system 300 includes at least two independent impedance reduction systems 301, 302 similar in construction and operation to that described previously with respect to FIGS. 2a and 2b. Although only two impedance reduction systems 301, 302 are shown in FIG. 3, it should be appreciated that additional impedance reduction systems may be provided.

As shown, a first impedance reduction system 301 of the at least two impedance reduction systems 301, 302 includes a first plurality of gel reservoirs 310a, each containing an electrically conductive gel, with each respective gel reservoir including a gel delivery outlet 320a. Each of the first plurality of gel reservoirs 310a is fluidly coupled to a first fluid channel 330a that is, in turn, fluidly coupled to a first fluid pressure source 340a. The first fluid pressure source 340a has an input 341a to receive a first electrical activation signal and a fluid outlet 342a that is fluidly coupled to the first fluid channel 330a. A rupturable membrane and/or a filter (not shown) may be positioned between the fluid outlet 342a and the first fluid channel 330a as described in the '134 patent. As described in the '134 patent, the first fluid pressure source 340a may include a gas generating cartridge that ignites a chemical pellet (such as a Lead Styphnate igniter and a gas generating mixture of Ammonium Dichromate and Nitroguanidine) that rapidly decomposes and generates quantities of a gas, such as

Nitrogen. It should be appreciated that other types of fluid pressure sources may be used, as the present invention is not limited to any particular type of fluid pressure source.

In response to the first activation signal received at the input 341a of the first fluid pressure source 340a, a fluid, such as Nitrogen gas, is forced into the first fluid channel 330a and then into each of the first plurality of gel reservoirs 310a. The hydraulic pressure of the fluid flowing into each of the first plurality of gel reservoirs 310a forces the electrically conductive gel contained in each gel reservoir toward its respective gel delivery outlet 320a, thereby fracturing a membrane separating the gel delivery outlet from a respective aperture formed in the electrically conductive layer of the electrode portion.

The second impedance reduction system 302 of the at least two impedance reduction systems 301, 302 is similar to the first impedance reduction system 301 and includes a second plurality of gel reservoirs 310b, each containing an electrically conductive gel, with each respective gel reservoir including a gel delivery outlet 320b. The electrically conductive gel contained in the second plurality of gel reservoirs 310b may, but need not, be the same type of gel as that contained in the first plurality of gel reservoirs 310a. For example, the electrically conductive gel contained in the second plurality of gel reservoirs 310b may have a different color, or have a longer drying time than the gel contained in the first plurality of gel reservoirs 310a. Each of the plurality of gel reservoirs 310b is fluidly coupled to a second fluid channel 330b that is, in turn, fluidly coupled to a second fluid pressure source 340b. The second fluid pressure source 340b has an input 341b to receive a second electrical activation signal and a fluid outlet 342b that is fluidly coupled to the second fluid channel 330b. The second fluid pressure source 340b may be similar in construction to the first fluid source 340a described above.

As shown in FIG. 3, the input 341a of the first fluid pressure source 340a may be electrically connected to the input 341b of the second fluid pressure source, such that a single activation signal activates each of the at least two impedance reduction systems 301, 302 substantially simultaneously. Should one of the redundant impedance reduction systems 301, 302 fail to operate (either partially or completely), the other can still operate to dispense conductive gel onto the exposed surface of the electrode. The activation signal provided to the input 341a of the first fluid pressure source 340a may be provided by the control unit 120 (FIG. 1) to the first fluid pressure source 340a using an electrical conductor that is physically distinct from that which provides the activation signal to the input 341b of the second fluid pressure source 340b to permit further redundancy, for example, should one of the electrical conductors be damaged. Alternatively, a single electrical conductor may be provided between the control unit 120 and the electrode assembly, with the single electrical conductor being connected to both the input 341a of the first fluid pressure source 340a and the input 341b of the second fluid pressure source 340b.

It should be appreciated that each of the first and second pressure sources 340a, 340b may alternatively receive separate activation signals, as the present invention is not limited to receiving a single activation signal. The separate activation signals may be sent, for example by the control unit 120, to each of the first fluid pressure source 340a and the second fluid pressure source 340b at substantially the same time, or at different times. For example, a first activation signal may be provided to the input 341a of the first fluid pressure source 340a at a first time, and a second activation signal may be provided to the input 341b of the second fluid pressure source

340b at a second time that is subsequent to the first time. In accordance with one embodiment, the control unit **120** (FIG. 1) may send the first activation signal to the first fluid pressure source **340a** at a first time, and send the second activation signal to the second fluid pressure source **340b** at a second and subsequent time where it is determined that the first impedance reduction system **301** failed to operate. Alternatively, the second activation signal may be sent to the second fluid pressure source **340b** at a second and subsequent time even where activation of the first fluid pressure source **340a** is successful. Such a subsequent activation of the second fluid pressure source **340b** would permit a second deployment of conductive gel onto the exposed surface of the electrode and permit the electrode to maintain a high conductivity with the patient for a longer period of time than if both impedance reduction systems **301**, **302** were activated at substantially the same time.

FIG. 4 illustrates an electrode assembly that combines one or more ECG sensing electrodes, a therapy electrode, and redundant impedance reduction systems in a single integrated electrode assembly in accordance with a further aspect of the present invention. As shown, the electrode assembly **400** includes a pair of ECG sensing electrodes **412a**, **412b** for monitoring the cardiac function of a patient. The electrode assembly **400** further includes a therapy electrode **414**, and at least two impedance reduction systems **301**, **302**, similar to those described previously with respect to FIG. 3. The pair of ECG sensing electrodes **412a**, **412b** may be electrically separated from the therapy electrode **414**, for example, by an insulator. It should be appreciated that in other embodiments, the electrode assembly **400** may include only a single ECG sensing electrode, while in other embodiments, more than two ECG sensing electrodes may be provided. In such alternative embodiments, the number and placement of ECG sensing electrodes and may vary from that shown in FIG. 4. In yet a further embodiment, the integrated electrode assembly can include additional sensors **416**, other than the one or more ECG sensing electrodes and the therapy electrode, that are capable of monitoring other physiological parameters of a patient, such as blood pressure, heart rate, thoracic impedance, pulse oxygen level, respiration rate, heart sounds, etc.

The electrode assembly **400** may be worn on the patient's body such that one of the pair of ECG sensing electrodes **412a**, **412b** is disposed approximately in the center of the patient's torso, and the other of the pair of ECG sensing electrodes **412a**, **412b** is disposed on the side of the patient's torso. For example, as shown in FIG. 5, the electrode assembly **400** may be worn on the front of the patient's torso, so that the ECG sensing electrode **412a** is disposed approximately in the center of the patient's chest, and the other ECG sensing electrode **412b** is disposed on the patient's side. A second electrode assembly **400'** may be worn on the back of the patient's torso to provide a second pair of ECG sensing electrodes **412a'**, **412b'**, so that one of the ECG sensing electrodes (e.g., ECG sensing electrode **412a'**) of the second pair of ECG sensing electrodes **400'** is disposed approximately in the center of the patient's back, and the other ECG sensing electrode (e.g., ECG sensing electrode **412b'**) of the second pair of ECG sensing electrodes **400'** is disposed on the patient's side opposite the other ECG sensing electrode (e.g., ECG sensing electrode **412b**) of the first pair of ECG sensing electrodes **412a**, **412b**, as shown in FIG. 5. Such an arrangement provides a front-to-back pairing of ECG sensing electrodes (e.g., **412a**, **412a'**) and a side-to-side pairing of ECG sensing electrodes (e.g., **412b**, **412b'**). It should be appreciated that other placements for the first electrode assembly **400** and the second electrode assembly **400'** may alternatively be used. For

example, the first electrode assembly **400** may be placed on one side of the patient's torso, and the second electrode assembly **400'** placed on the other side of the patient's torso to provide side-to-side pairings of ECG sensing electrodes.

Having thus described several aspects of at least one embodiment of this invention, it is to be appreciated various alterations, modifications, and improvements will readily occur to those skilled in the art. Such alterations, modifications, and improvements are intended to be part of this disclosure, and are intended to be within the scope of the invention. Accordingly, the foregoing description and drawings are by way of example only.

What is claimed is:

1. A method of reducing impedance between a defibrillation electrode and a patient's skin, comprising acts of:

sending a first activation signal to a first impedance reduction system configured to dispense, in response to receipt of the first activation signal, a first amount of a first electrically conductive gel onto a surface of the defibrillation electrode that is configured to be disposed adjacent the patient's skin; and

sending a second activation signal that is distinct from the first activation signal to a second impedance reduction system configured to dispense, in response to receipt of the second activation signal, a second amount of a second electrically conductive gel onto the surface of the defibrillation electrode that is configured to be disposed adjacent the patient's skin, the second impedance reduction system being distinct from the first impedance reduction system and independently operable of the first impedance reduction system.

2. The method of claim 1, wherein the act of sending the second activation signal is performed substantially simultaneously with the act of sending the first activation signal.

3. The method of claim 1, wherein the act of sending the second activation signal is performed subsequent to the act of sending the first activation signal.

4. The method of claim 1, wherein the act of sending the first activation signal is performed at a first time, and wherein the act of sending the second activation signal is performed at a second time that is substantially after the first time to maintain the impedance between the defibrillation electrode and patient's skin in a reduced state for an extended duration.

5. The method of claim 4, wherein the second electrically conductive gel has a longer drying time than the first electrically conductive gel.

6. The method of claim 1, further comprising an act of determining whether the first impedance reduction system dispensed the first amount of the first electrically conductive gel onto the surface of the defibrillation electrode, wherein the act of sending the second activation signal to the second impedance reduction system is performed in response to a determination that the first impedance reduction system did not dispense the first amount of the first electrically conductive gel onto the surface of the defibrillation electrode.

7. The method of claim 1, wherein the act of sending the second activation signal is performed independent of whether the first impedance reduction system dispensed the first amount of the first electrically conductive gel onto the surface of the defibrillation electrode.

8. The method of claim 1, wherein the defibrillation electrode includes an electrically conductive layer and the first impedance reduction system dispenses the first amount of the first electrically conductive gel onto a surface of the electrically conductive layer in response to the first activation signal.

9. The method of claim 8, wherein the second impedance reduction system dispenses the second amount of the second

11

electrically conductive gel onto the surface of the electrically conductive layer in response to the second activation signal.

10. The method of claim 8, wherein the electrically conductive layer includes a first plurality of apertures and the first impedance reduction system dispenses the first amount of the first electrically conductive gel through the first plurality of apertures onto the surface of the electrically conductive layer in response to the first activation signal.

11. The method of claim 10, wherein the electrically conductive layer includes a second plurality of apertures and the second impedance reduction system dispenses the second amount of the second electrically conductive gel through the second plurality of apertures onto the surface of the electrically conductive layer in response to the second activation signal.

12. The method of claim 1, wherein the defibrillation electrode includes a first fluid pressure source in fluid communication with a first fluid channel and a first plurality of gel reservoirs, and the first fluid pressure source forces a first fluid under pressure into the first fluid channel in response to receiving the first activation signal.

13. The method of claim 12, wherein the defibrillation electrode includes a second fluid pressure source in fluid communication with a second fluid channel and a second

12

plurality of gel reservoirs, and the second pressure source forces a second fluid under pressure into the second fluid channel in response to receiving the second activation signal.

14. The method of claim 13, wherein a pressure of the first fluid forces the first electrically conductive gel stored in each of the first plurality of gel reservoirs through apertures formed in an electrically conductive layer of the defibrillation electrode and onto an exposed surface of the electrically conductive layer that, in use, is placed most proximate the skin of the patient.

15. The method of claim 14, wherein a pressure of the second fluid forces the second electrically conductive gel stored in each of the second plurality of gel reservoirs through the apertures formed in the electrically conductive layer of the defibrillation electrode and onto the exposed surface of the electrically conductive layer that, in use, is placed most proximate the skin of the patient.

16. The method of claim 13, wherein the first activation signal is provided to the first fluid pressure source using an electrical conductor that is physically distinct from an electrical conductor which provides the second activation signal to the second fluid pressure source.

* * * * *

专利名称(译)	具有冗余阻抗降低的电极		
公开(公告)号	US9037271	公开(公告)日	2015-05-19
申请号	US13/849751	申请日	2013-03-25
[标]申请(专利权)人(译)	卓尔医学产品公司		
当前申请(专利权)人(译)	ZOLL医疗公司		
[标]发明人	KAIB THOMAS E VOLPE SHANE S OSKIN EMIL		
发明人	KAIB, THOMAS E. VOLPE, SHANE S. OSKIN, EMIL		
IPC分类号	A61N1/39 A61N1/37 A61B5/00 A61B5/04 A61N1/04 A61N1/08		
CPC分类号	A61N1/046 A61B5/04 A61B5/6804 A61B5/6823 A61N2001/083 A61N1/39 A61B2562/14 A61N1/3925 A61M35/003 A61N1/0496		
优先权	61/421283 2010-12-09 US		
其他公开文献	US20130218252A1		
外部链接	Espacenet USPTO		

摘要(译)

一种电极组件，包括导电层，第一阻抗减小系统和第二阻抗减小系统。导电层形成电极组件的电极部分和第一表面，该第一表面邻近人的皮肤放置。第一阻抗减小系统被配置为响应于第一激活信号将第一量的导电凝胶分配到导电层的第一表面上。第二阻抗减小系统被配置为响应于第二激活信号将第二量的导电凝胶分配到导电层的第一表面上。

