



US010149616B2

(12) **United States Patent**  
**Al-Ali et al.**

(10) **Patent No.:** **US 10,149,616 B2**  
(45) **Date of Patent:** **Dec. 11, 2018**

(54) **WIRELESS PATIENT MONITORING DEVICE**

(2013.01); *A61B 2560/0214* (2013.01); *A61B 2560/0266* (2013.01); *A61B 2560/0475* (2013.01)

(71) Applicant: **MASIMO CORPORATION**, Irvine, CA (US)

(58) **Field of Classification Search**

CPC ... *A61B 5/0002*; *A61B 5/0024*; *H04W 84/02*; *H04W 88/00*; *G06F 19/34*  
USPC ..... 600/522, 523; 455/103  
See application file for complete search history.

(72) Inventors: **Ammar Al-Ali**, San Juan Capistrano, CA (US); **Eric Karl Kinast**, Santa Ana, CA (US); **Bilal Muhsin**, San Clemente, CA (US); **Chad A. Dejong**, Los Angeles, CA (US)

(56) **References Cited**

U.S. PATENT DOCUMENTS

3,646,606 A 2/1972 Buxton et al.  
3,690,313 A 9/1972 Weber et al.  
3,810,102 A 5/1974 Parks, III et al.  
3,815,583 A 6/1974 Scheidt  
3,972,320 A 8/1976 Kalman  
3,978,849 A 9/1976 Geneen  
4,108,166 A 8/1978 Schmid

(Continued)

(73) Assignee: **Masimo Corporation**, Irvine, CA (US)

(\* ) Notice: Subject to any disclaimer, the term of this patent is extended or adjusted under 35 U.S.C. 154(b) by 419 days.

FOREIGN PATENT DOCUMENTS

EP 735499 10/1996  
EP 2335569 6/2011

(Continued)

(21) Appl. No.: **13/762,270**

(22) Filed: **Feb. 7, 2013**

(65) **Prior Publication Data**

US 2013/0253334 A1 Sep. 26, 2013

**Related U.S. Application Data**

(60) Provisional application No. 61/703,713, filed on Sep. 20, 2012, provisional application No. 61/625,584, filed on Apr. 17, 2012, provisional application No. 61/597,126, filed on Feb. 9, 2012.

OTHER PUBLICATIONS

US 8,845,543, 09/2014, Diab et al. (withdrawn)

(Continued)

(51) **Int. Cl.**

*A61B 6/00* (2006.01)  
*A61B 5/00* (2006.01)  
*A61B 5/024* (2006.01)  
*A61B 5/1455* (2006.01)

*Primary Examiner* — Timothy J Neal

*Assistant Examiner* — Jae Woo

(74) *Attorney, Agent, or Firm* — Knobbe Martens Olson & Bear LLP

(52) **U.S. Cl.**

CPC ..... *A61B 5/0024* (2013.01); *A61B 5/002* (2013.01); *A61B 5/0022* (2013.01); *A61B 5/0059* (2013.01); *A61B 5/02416* (2013.01); *A61B 5/14551* (2013.01); *A61B 5/7445*

(57) **ABSTRACT**

A device for obtaining physiological information of a medical patient and wirelessly transmitting the obtained physiological information to a wireless receiver.

**9 Claims, 35 Drawing Sheets**

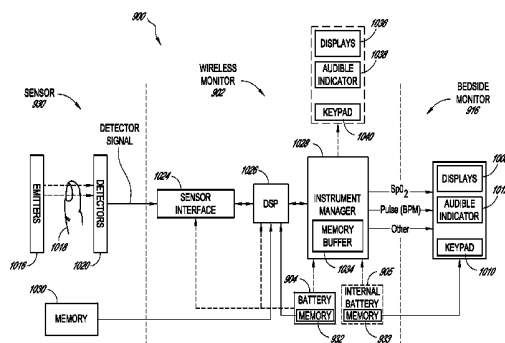
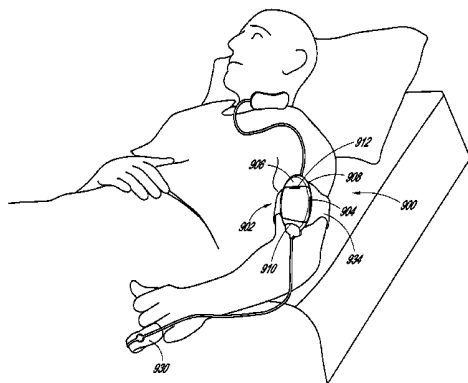

(56)

References Cited

U.S. PATENT DOCUMENTS

4,231,354 A	11/1980	Kurtz et al.	5,724,983 A	3/1998	Selker et al.
4,589,415 A	5/1986	Haaga	5,725,308 A	3/1998	Smith et al.
4,662,378 A	5/1987	Thomis	5,734,739 A	3/1998	Sheehan et al.
4,838,275 A	6/1989	Lee	393,830 A	4/1998	Tobler et al.
4,852,570 A	8/1989	Levine	5,743,262 A	4/1998	Lepper, Jr. et al.
4,960,128 A	10/1990	Gordon et al.	5,758,079 A	5/1998	Ludwig et al.
4,964,408 A	10/1990	Hink et al.	5,758,644 A	6/1998	Diab et al.
5,041,187 A	8/1991	Hink et al.	5,760,910 A	6/1998	Lepper, Jr. et al.
5,069,213 A	12/1991	Polczynski	5,769,785 A	6/1998	Diab et al.
5,092,340 A	3/1992	Yamaguchi et al.	5,772,585 A	6/1998	Lavin et al.
5,140,519 A	8/1992	Friesdorf et al.	5,782,757 A	7/1998	Diab et al.
5,159,932 A	11/1992	Zanetti et al.	5,782,805 A *	7/1998	Meinzer et al. .... 604/131
5,161,539 A	11/1992	Evans et al.	5,785,659 A	7/1998	Caro et al.
5,163,438 A	11/1992	Gordon et al.	5,791,347 A	8/1998	Flaherty et al.
5,262,944 A	11/1993	Weisner et al.	5,801,637 A *	9/1998	Lomholt ..... 340/815.69
5,277,189 A	1/1994	Jacobs	5,810,734 A	9/1998	Caro et al.
5,278,627 A	1/1994	Aoyagi et al.	5,813,403 A	9/1998	Soller et al.
5,282,474 A	2/1994	Valdes Sosa et al.	5,822,544 A	10/1998	Chaco et al.
5,296,688 A	3/1994	Hamilton et al.	5,822,546 A	10/1998	George
5,318,037 A	6/1994	Evans et al.	5,823,950 A	10/1998	Diab et al.
5,319,355 A	6/1994	Russek	5,829,723 A	11/1998	Brunner
5,331,549 A	7/1994	Crawford, Jr.	5,830,131 A	11/1998	Caro et al.
5,333,106 A	7/1994	Lanpher et al.	5,833,618 A	11/1998	Caro et al.
5,337,744 A	8/1994	Branigan	5,855,550 A	1/1999	Lai et al.
5,341,805 A	8/1994	Stavridi et al.	5,860,919 A	1/1999	Kiani-Azarbayjany et al.
5,348,008 A	9/1994	Bornn et al.	5,876,351 A	3/1999	Rohde
5,358,519 A	10/1994	Grandjean	5,890,929 A	4/1999	Mills et al.
D353,195 S	12/1994	Savage et al.	5,904,654 A	5/1999	Wohlmann et al.
D353,196 S	12/1994	Savage et al.	5,910,139 A	6/1999	Cochran et al.
5,375,599 A	12/1994	Schimizu	5,919,134 A	7/1999	Diab
5,375,604 A	12/1994	Kelly	5,921,920 A	7/1999	Marshall et al.
5,377,676 A	1/1995	Vari et al.	5,924,074 A	7/1999	Evans
5,400,794 A	3/1995	Gorman	5,931,160 A	8/1999	Gilmore et al.
D357,982 S	5/1995	Dahl et al.	5,931,791 A	8/1999	Saltzstein et al.
5,416,695 A	5/1995	Stutman et al.	5,934,925 A	8/1999	Tobler et al.
D359,546 S	6/1995	Savage et al.	5,940,182 A	8/1999	Lepper, Jr. et al.
5,431,170 A	7/1995	Mathews	5,942,986 A	8/1999	Shabot et al.
5,434,611 A	7/1995	Tamura	5,987,519 A	11/1999	Peifer et al.
D361,840 S	8/1995	Savage et al.	5,995,855 A	11/1999	Kiani et al.
D362,063 S	9/1995	Savage et al.	5,997,343 A	12/1999	Mills et al.
5,452,717 A	9/1995	Branigan et al.	6,002,952 A	12/1999	Diab et al.
D363,120 S	10/1995	Savage et al.	6,006,119 A	12/1999	Soller et al.
5,456,252 A	10/1995	Vari et al.	6,011,986 A	1/2000	Diab et al.
5,479,934 A	1/1996	Imran	6,014,346 A	1/2000	Malone
5,482,036 A	1/1996	Diab et al.	6,018,673 A	1/2000	Chin et al.
5,483,968 A	1/1996	Adam et al.	6,024,699 A	2/2000	Surwit et al.
5,490,505 A	2/1996	Diab et al.	6,027,452 A	2/2000	Flaherty et al.
5,494,041 A	2/1996	Wilk	6,032,678 A	3/2000	Rottem
5,494,043 A	2/1996	O'Sullivan et al.	6,035,230 A	3/2000	Kang
5,503,149 A	4/1996	Beavin	6,036,642 A	3/2000	Diab et al.
5,505,202 A	4/1996	Mogi et al.	6,036,718 A	3/2000	Ledford et al.
5,533,511 A	7/1996	Kaspari et al.	6,045,509 A	4/2000	Caro et al.
5,534,851 A	7/1996	Russek	6,045,527 A	4/2000	Appelbaum et al.
5,537,289 A	7/1996	Dahl	6,057,758 A	5/2000	Dempsey et al.
5,544,649 A	8/1996	David et al.	6,067,462 A	5/2000	Diab et al.
5,553,609 A	9/1996	Chen et al.	6,081,735 A	6/2000	Diab et al.
5,558,638 A	9/1996	Evers et al.	6,088,607 A	7/2000	Diab et al.
5,561,275 A	10/1996	Savage et al.	6,093,146 A	7/2000	Filangeri
5,562,002 A	10/1996	Lalin	6,101,478 A	8/2000	Brown
5,566,676 A *	10/1996	Rosenfeldt et al. .... 600/485	6,106,463 A	8/2000	Wilk
5,576,952 A	11/1996	Stutman et al.	6,110,522 A	8/2000	Lepper, Jr. et al.
5,579,001 A	11/1996	Dempsey et al.	6,124,597 A	9/2000	Shehada
5,590,649 A	1/1997	Caro et al.	6,128,521 A	10/2000	Marro et al.
5,602,924 A	2/1997	Durand et al.	6,129,675 A	10/2000	Jay
5,619,991 A	4/1997	Sloane	6,132,218 A	10/2000	Benja-Athon
5,632,272 A	5/1997	Diab et al.	6,139,494 A	10/2000	Cairnes
5,638,816 A	6/1997	Kiani-Azarbayjany et al.	6,144,868 A	11/2000	Parker
5,638,818 A	6/1997	Diab et al.	6,151,516 A	11/2000	Kiani-Azarbayjany et al.
5,640,967 A	6/1997	Fine et al.	6,152,754 A	11/2000	Gerhardt et al.
5,645,440 A	7/1997	Tobler et al.	6,157,850 A	12/2000	Diab et al.
5,685,299 A	11/1997	Diab et al.	6,165,005 A	12/2000	Mills et al.
5,685,314 A	11/1997	Geheb et al.	6,167,258 A	12/2000	Schmidt et al.
5,687,717 A	11/1997	Halpern et al.	D437,058 S	1/2001	Gozani
5,694,020 A *	12/1997	Lang et al. .... 30/45	6,168,563 B1	1/2001	Brown
5,724,580 A	3/1998	Levin et al.	6,171,237 B1	1/2001	Avitall et al.
			6,175,752 B1	1/2001	Say et al.
			6,183,417 B1	2/2001	Gehab et al.
			6,184,521 B1	2/2001	Coffin, IV et al.
			6,185,448 B1	2/2001	Borovsky

(56)

## References Cited

## U.S. PATENT DOCUMENTS

6,195,576 B1	2/2001	John	6,650,917 B2	11/2003	Diab et al.
6,206,830 B1	3/2001	Diab et al.	6,650,939 B2	11/2003	Takpke, II et al.
6,221,012 B1	4/2001	Maschke et al.	6,654,624 B2	11/2003	Diab et al.
6,224,553 B1	5/2001	Nevo	D483,872 S	12/2003	Cruz et al.
6,229,856 B1	5/2001	Diab et al.	6,658,276 B2	12/2003	Kiani et al.
6,230,142 B1	5/2001	Benigno et al.	6,661,161 B1	12/2003	Lanzo et al.
6,232,609 B1	5/2001	Snyder et al.	6,663,570 B2	12/2003	Mott et al.
6,236,872 B1	5/2001	Diab et al.	6,671,531 B2	12/2003	Al-Ali et al.
6,241,683 B1	6/2001	Macklem et al.	6,678,543 B2	1/2004	Diab et al.
6,251,113 B1	6/2001	Appelbaum	6,684,090 B2	1/2004	Ali et al.
6,253,097 B1	6/2001	Aronow et al.	6,684,091 B2	1/2004	Parker
6,256,523 B1	7/2001	Diab et al.	6,694,180 B1 *	2/2004	Boesen ..... 600/547
6,263,222 B1	7/2001	Diab et al.	6,697,656 B1	2/2004	Al-Ali
6,267,723 B1 *	7/2001	Matsumura et al. .... 600/300	6,697,657 B1	2/2004	Shehada et al.
6,269,262 B1	7/2001	Kandori et al.	6,697,658 B2	2/2004	Al-Ali
6,278,522 B1	8/2001	Lepper, Jr. et al.	RE38,476 E	3/2004	Diab et al.
6,280,213 B1	8/2001	Tobler et al.	6,699,194 B1	3/2004	Diab et al.
6,285,896 B1	9/2001	Tobler et al.	6,714,804 B2	3/2004	Al-Ali et al.
6,301,493 B1	10/2001	Marro et al.	RE38,492 E	4/2004	Diab et al.
6,304,767 B1	10/2001	Soller et al.	6,719,694 B2	4/2004	Weng et al.
6,312,378 B1	11/2001	Bardy	6,721,582 B2	4/2004	Trepagnier et al.
6,317,627 B1	11/2001	Ennen et al.	6,721,585 B1	4/2004	Parker
6,321,100 B1	11/2001	Parker	6,725,075 B2	4/2004	Al-Ali
6,322,502 B1	11/2001	Schoenberg et al.	6,725,086 B2	4/2004	Marinello
6,325,761 B1	12/2001	Jay	6,728,560 B2	4/2004	Kollias et al.
6,329,139 B1	12/2001	Nova et al.	6,735,459 B2	5/2004	Parker
6,334,065 B1	12/2001	Al-Ali et al.	6,745,060 B2	6/2004	Diab et al.
6,338,039 B1	1/2002	Lonski et al.	6,746,406 B2	6/2004	Lia et al.
6,343,224 B1	1/2002	Parker	6,750,463 B1	6/2004	Riley
6,349,228 B1	2/2002	Kiani et al.	6,751,492 B2	6/2004	Ben-Haim
6,352,504 B1	3/2002	Ise	6,760,607 B2	7/2004	Al-Ali
6,354,235 B1 *	3/2002	Davies ..... 114/246	6,766,188 B2	7/2004	Soller
6,360,114 B1	3/2002	Diab et al.	6,770,028 B1	8/2004	Ali et al.
6,364,834 B1	4/2002	Reuss et al.	6,771,994 B2	8/2004	Kiani et al.
6,364,839 B1	4/2002	Little et al.	6,783,492 B2	8/2004	Dominguez
6,368,283 B1	4/2002	Xu et al.	6,790,178 B1	9/2004	Mault et al.
6,371,921 B1	4/2002	Caro et al.	6,792,300 B1	9/2004	Diab et al.
6,377,829 B1	4/2002	Al-Ali	6,795,724 B2	9/2004	Hogan
6,385,476 B1	5/2002	Osadchy et al.	6,796,186 B2	9/2004	Lia et al.
6,385,589 B1	5/2002	Trusheim et al.	6,804,656 B1	10/2004	Rosenfeld
6,388,240 B2	5/2002	Schulz et al.	6,807,050 B1	10/2004	Whitehorn et al.
6,397,091 B2	5/2002	Diab et al.	6,813,511 B2	11/2004	Diab et al.
6,407,335 B1	6/2002	Franklin-Lees	6,816,741 B2	11/2004	Diab
6,430,437 B1	8/2002	Marro	6,817,979 B2	11/2004	Nihtila et al.
6,430,525 B1	8/2002	Weber et al.	6,822,564 B2	11/2004	Al-Ali
6,463,311 B1	10/2002	Diab	6,826,419 B2	11/2004	Diab et al.
6,470,199 B1	10/2002	Kopotic et al.	6,830,711 B2	12/2004	Mills et al.
6,470,893 B1	12/2002	Boesen	6,837,848 B2	1/2005	Bonner et al.
6,501,975 B2	12/2002	Diab et al.	6,841,535 B2	1/2005	Divita et al.
6,505,059 B1	1/2003	Kollias et al.	6,850,787 B2	2/2005	Weber et al.
6,515,273 B2	2/2003	Al-Ali	6,850,788 B2	2/2005	Al-Ali
6,519,487 B1	2/2003	Parker	6,852,083 B2	2/2005	Caro et al.
6,524,240 B1	2/2003	Thede	6,855,112 B2	2/2005	Kao et al.
6,525,386 B1	2/2003	Mills et al.	6,860,266 B2	3/2005	Blike
6,526,300 B1	2/2003	Kiani et al.	6,861,639 B2	3/2005	Al-Ali
6,541,756 B2	4/2003	Schulz et al.	6,897,788 B2	5/2005	Khair et al.
6,542,764 B1	4/2003	Al-Ali et al.	6,898,452 B2	5/2005	Al-Ali et al.
6,544,173 B2	4/2003	West et al.	6,907,237 B1 *	6/2005	Dorenbosch et al. .... 455/404.1
6,544,174 B2 *	4/2003	West et al. .... 600/300	6,915,149 B2	7/2005	Ben-haim
6,551,243 B2	4/2003	Bocionek et al.	6,920,345 B2	7/2005	Al-Ali et al.
6,578,428 B1	6/2003	Dromms et al.	6,931,268 B1	8/2005	Kiani-Azarbayjany et al.
6,580,086 B1	6/2003	Schulz et al.	6,934,570 B2	8/2005	Kiani et al.
6,582,393 B2	6/2003	Sage, Jr.	6,939,305 B2	9/2005	Flaherty et al.
6,584,336 B1	6/2003	Ali et al.	6,943,348 B1	9/2005	Coffin, IV
6,595,316 B2	7/2003	Cybulski et al.	6,950,687 B2	9/2005	Al-Ali
6,597,932 B2	7/2003	Tian et al.	6,952,340 B2	10/2005	Son
6,597,933 B2	7/2003	Kiani et al.	6,961,598 B2	11/2005	Diab
6,606,511 B1	8/2003	Ali et al.	6,970,792 B1	11/2005	Diab
6,616,606 B1 *	9/2003	Petersen et al. .... 600/300	6,979,812 B2	12/2005	Al-Ali
6,632,181 B2	10/2003	Flaherty et al.	6,980,419 B2	12/2005	Smith et al.
6,639,668 B1	10/2003	Trepagnier	6,983,179 B2	1/2006	Ben-Haim
6,640,116 B2	10/2003	Diab	6,985,764 B2	1/2006	Mason et al.
6,641,533 B2	11/2003	Causey et al.	6,988,989 B2 *	1/2006	Weiner et al. .... 600/300
6,643,530 B2	11/2003	Diab et al.	6,990,087 B2 *	1/2006	Rao et al. .... 370/330
6,646,556 B1	11/2003	Smith et al.	6,993,371 B2	1/2006	Kiani et al.
			6,996,427 B2	2/2006	Ali et al.
			6,997,884 B2	2/2006	Ulmsten
			6,999,904 B2	2/2006	Weber et al.
			7,003,338 B2	2/2006	Weber et al.

(56)

## References Cited

## U.S. PATENT DOCUMENTS

7,003,339 B2	2/2006	Diab et al.	7,373,193 B2	5/2008	Al-Ali et al.
7,004,907 B2	2/2006	Banet et al.	7,373,194 B2	5/2008	Weber et al.
7,015,451 B2	3/2006	Dalke et al.	7,376,453 B1	5/2008	Diab et al.
7,024,233 B2	4/2006	Ali et al.	7,377,794 B2	5/2008	Al Ali et al.
7,025,729 B2	4/2006	De Chazal et al.	7,377,899 B2	5/2008	Weber et al.
7,027,849 B2	4/2006	Al-Ali	7,378,975 B1	5/2008	Smith et al.
7,030,749 B2	4/2006	Al-Ali	7,382,247 B2 *	6/2008	Welch et al. .... 340/539.12
7,033,761 B2	4/2006	Shafer	7,383,070 B2	6/2008	Diab et al.
7,035,686 B2	4/2006	Hogan	7,390,299 B2	6/2008	Weiner et al.
7,039,449 B2	5/2006	Al-Ali	7,395,216 B2	7/2008	Rosenfeld
7,041,060 B2	5/2006	Flaherty et al.	7,396,330 B2	7/2008	Banet et al.
7,044,918 B2	5/2006	Diab	7,411,509 B2	8/2008	Rosenfeld
7,044,930 B2	5/2006	Stromberg	7,413,546 B2	8/2008	Agutter et al.
7,063,666 B2	6/2006	Weng et al.	7,415,297 B2	8/2008	Al-Ali et al.
7,067,893 B2	6/2006	Mills et al.	7,419,483 B2	9/2008	Shehada
7,079,035 B2	7/2006	Bock et al.	7,428,432 B2	9/2008	Ali et al.
7,096,052 B2	8/2006	Mason et al.	7,433,827 B2	10/2008	Rosenfeld
7,096,054 B2	8/2006	Abdul-Hafiz et al.	7,438,683 B2	10/2008	Al-Ali et al.
7,132,641 B2	11/2006	Schulz et al.	7,439,856 B2 *	10/2008	Weiner et al. .... 340/539.12
7,142,901 B2	11/2006	Kiani et al.	7,440,787 B2	10/2008	Diab
7,149,561 B2	12/2006	Diab	7,454,240 B2	11/2008	Diab et al.
7,179,228 B2	2/2007	Banet	7,454,359 B2	11/2008	Rosenfeld
7,186,966 B2	3/2007	Al-Ali	7,454,360 B2	11/2008	Rosenfeld
7,188,621 B2	3/2007	DeVries et al.	7,462,151 B2	12/2008	Childre et al.
7,190,261 B2	3/2007	Al-Ali	7,467,002 B2	12/2008	Weber et al.
7,208,119 B1	4/2007	Kurtock et al.	7,467,094 B2	12/2008	Rosenfeld
7,215,984 B2	5/2007	Diab	7,469,157 B2	12/2008	Diab et al.
7,215,986 B2	5/2007	Diab	7,471,969 B2	12/2008	Diab et al.
7,221,971 B2	5/2007	Diab	7,471,971 B2	12/2008	Diab et al.
7,225,006 B2	5/2007	Al-Ali et al.	7,475,019 B2	1/2009	Rosenfeld
7,225,007 B2	5/2007	Al-Ali	7,481,772 B2	1/2009	Banet
RE39,672 E	6/2007	Shehada et al.	7,483,729 B2	1/2009	Al-Ali et al.
7,229,415 B2	6/2007	Schwartz	7,483,730 B2	1/2009	Diab et al.
7,238,159 B2	7/2007	Banet et al.	7,489,250 B2	2/2009	Bock et al.
7,239,905 B2	7/2007	Kiani-Azarbayjany et al.	7,489,958 B2	2/2009	Diab et al.
7,241,287 B2	7/2007	Shehada et al.	7,496,391 B2	2/2009	Diab et al.
7,244,251 B2	7/2007	Shehada et al.	7,496,393 B2	2/2009	Diab et al.
7,245,373 B2	7/2007	Soller et al.	D587,657 S	3/2009	Al-Ali et al.
7,245,953 B1	7/2007	Parker	7,497,828 B1	3/2009	Wilk et al.
7,252,659 B2	8/2007	Shehada et al.	7,499,741 B2	3/2009	Diab et al.
7,254,429 B2	8/2007	Schurman et al.	7,499,835 B2	3/2009	Weber et al.
7,254,431 B2	8/2007	Al-Ali	7,500,950 B2	3/2009	Al-Ali et al.
7,254,433 B2	8/2007	Diab et al.	7,509,154 B2	3/2009	Diab et al.
7,254,434 B2	8/2007	Schulz et al.	7,509,494 B2	3/2009	Al-Ali
7,256,708 B2	8/2007	Rosenfeld	7,510,849 B2	3/2009	Schurman et al.
7,261,697 B2	8/2007	Berstein	7,515,043 B2	4/2009	Welch et al.
7,264,616 B2	9/2007	Shehada et al.	7,515,044 B2	4/2009	Welch et al.
7,267,671 B2	9/2007	Shehada et al.	7,526,328 B2	4/2009	Diab et al.
7,268,859 B2	9/2007	Sage, Jr. et al.	7,530,942 B1	5/2009	Diab
7,272,425 B2	9/2007	Al-Ali	7,530,949 B2	5/2009	Al Ali et al.
7,274,955 B2	9/2007	Kiani et al.	7,530,955 B2	5/2009	Diab et al.
D554,263 S	10/2007	Al-Ali	7,532,919 B2	5/2009	Soyemi et al.
7,280,858 B2	10/2007	Al-Ali et al.	7,549,961 B1	6/2009	Hwang
7,285,090 B2	10/2007	Stivoric	7,551,717 B2	6/2009	Tome et al.
7,289,835 B2	10/2007	Mansfield et al.	7,559,520 B2	7/2009	Quijano et al.
7,292,883 B2	11/2007	De Felice et al.	7,563,110 B2	7/2009	Al-Ali et al.
7,295,866 B2	11/2007	Al-Ali	7,577,475 B2	8/2009	Consentino et al.
7,307,543 B2	12/2007	Rosenfeld	7,588,558 B2	9/2009	Sage, Jr. et al.
7,313,423 B2	12/2007	Griffin et al.	7,590,950 B2 *	9/2009	Collins et al. .... 715/864
7,314,446 B2	1/2008	Byrd et al.	7,596,398 B2	9/2009	Al-Ali et al.
7,315,825 B2	1/2008	Rosenfeld	7,597,665 B2	10/2009	Wilk et al.
7,321,862 B2	1/2008	Rosenfeld	7,612,999 B2	11/2009	Clark et al.
7,322,971 B2	1/2008	Shehada et al.	7,616,303 B2	11/2009	Yang et al.
7,328,053 B1	2/2008	Diab et al.	7,618,375 B2	11/2009	Flaherty
7,332,784 B2	2/2008	Mills et al.	D606,659 S	12/2009	Kiani et al.
7,336,187 B2	2/2008	Hubbard, Jr. et al.	7,639,145 B2	12/2009	Lawson et al.
7,340,287 B2	3/2008	Mason et al.	7,647,083 B2	1/2010	Al-Ali et al.
7,341,559 B2	3/2008	Schulz et al.	7,650,291 B2	1/2010	Rosenfeld
7,343,186 B2	3/2008	Lamego et al.	D609,193 S	2/2010	Al-Ali et al.
D566,282 S	4/2008	Al-Ali et al.	7,654,966 B2	2/2010	Westinskow et al.
7,355,512 B1	4/2008	Al-Ali	7,658,716 B2	2/2010	Banet et al.
7,356,178 B2	4/2008	Ziel et al.	7,684,845 B2	3/2010	Juan
7,356,365 B2	4/2008	Schurman	7,689,437 B1	3/2010	Teller et al.
7,361,155 B2	4/2008	Sage, Jr. et al.	RE41,236 E	4/2010	Seely
7,371,981 B2	5/2008	Abdul-Hafiz	D614,305 S	4/2010	Al-Ali et al.
			7,693,697 B2	4/2010	Westinskow et al.
			RE41,317 E	5/2010	Parker
			7,722,542 B2	5/2010	Lia et al.
			7,729,733 B2	6/2010	Al-Ali et al.

(56)

## References Cited

## U.S. PATENT DOCUMENTS

7,734,320 B2	6/2010	Al-Ali	8,046,041 B2	10/2011	Diab et al.
7,736,318 B2	6/2010	Consentino et al.	8,046,042 B2	10/2011	Diab et al.
7,740,590 B2	6/2010	Bernstein	8,048,040 B2	11/2011	Kiani
7,761,127 B2	7/2010	Al-Ali et al.	8,050,728 B2	11/2011	Al-Ali et al.
7,761,128 B2	7/2010	Al-Ali et al.	8,068,104 B2	11/2011	Rampersad
7,763,420 B2	7/2010	Strizker et al.	8,073,707 B2	12/2011	Teller et al.
7,764,982 B2	7/2010	Dalke et al.	8,094,013 B1	1/2012	Lee et al.
D621,515 S	8/2010	Chua et al.	RE43,169 E	2/2012	Parker
D621,516 S	8/2010	Kiani et al.	8,118,620 B2	2/2012	Al-Ali et al.
7,766,818 B2	8/2010	Iketani et al.	8,126,528 B2	2/2012	Diab et al.
7,774,060 B2	8/2010	Westenskow et al.	8,128,572 B2	3/2012	Diab et al.
7,778,851 B2	8/2010	Schoenberg et al.	8,130,105 B2	3/2012	Al-Ali et al.
7,791,155 B2	9/2010	Diab	8,145,287 B2	3/2012	Diab et al.
7,794,407 B2	9/2010	Rothenberg	8,150,487 B2	4/2012	Diab et al.
7,801,581 B2	9/2010	Diab	D659,836 S	5/2012	Bensch et al.
7,803,120 B2	9/2010	Banet et al.	8,170,887 B2	5/2012	Rosenfeld
7,806,830 B2	10/2010	Bernstein	8,175,672 B2	5/2012	Parker
7,820,184 B2	10/2010	Strizker et al.	8,175,895 B2	5/2012	Rosenfeld
7,822,452 B2	10/2010	Schurman et al.	8,180,420 B2	5/2012	Diab et al.
RE41,912 E	11/2010	Parker	8,180,440 B2	5/2012	McCombie et al.
7,831,450 B2	11/2010	Schoenberg	8,182,443 B1	5/2012	Kiani
7,841,986 B2	11/2010	He et al.	8,185,180 B2	5/2012	Diab et al.
7,844,313 B2	11/2010	Kiani et al.	8,190,223 B2	5/2012	Al-Ali et al.
7,844,314 B2	11/2010	Al-Ali	8,190,227 B2	5/2012	Diab et al.
7,844,315 B2	11/2010	Al-Ali	8,200,308 B2	6/2012	Zhang et al.
7,848,935 B2	12/2010	Gotlib	8,200,321 B2	6/2012	McCombie et al.
7,858,322 B2	12/2010	Tymianski et al.	8,203,438 B2	6/2012	Kiani et al.
7,865,222 B2	1/2011	Weber et al.	8,203,704 B2	6/2012	Merritt et al.
7,865,232 B1	1/2011	Krishnaswamy et al.	8,204,566 B2	6/2012	Schurman et al.
7,873,497 B2	1/2011	Weber et al.	8,206,312 B2	6/2012	Farquhar
7,880,606 B2	2/2011	Al-Ali	8,214,007 B2	7/2012	Baker et al.
7,880,626 B2	2/2011	Al-Ali et al.	8,219,172 B2	7/2012	Schurman et al.
7,881,892 B2	2/2011	Soyemi et al.	8,224,411 B2	7/2012	Al-Ali et al.
7,884,314 B2	2/2011	Hamada	8,228,181 B2	7/2012	Al-Ali
7,890,156 B2	2/2011	Ooi et al.	8,229,533 B2	7/2012	Diab et al.
7,891,355 B2	2/2011	Al-Ali et al.	8,233,955 B2	7/2012	Al-Ali et al.
7,894,868 B2	2/2011	Al-Ali et al.	8,235,907 B2	8/2012	Wilk et al.
7,899,507 B2	3/2011	Al-Ali et al.	8,239,010 B2	8/2012	Banet et al.
7,899,518 B2	3/2011	Trepagnier et al.	8,239,780 B2	8/2012	Manetta et al.
7,904,132 B2	3/2011	Weber et al.	8,241,213 B2	8/2012	Lynn et al.
7,909,772 B2	3/2011	Popov et al.	8,244,325 B2	8/2012	Al-Ali et al.
7,910,875 B2	3/2011	Al-Ali	8,249,815 B2	8/2012	Taylor
7,914,514 B2	3/2011	Calderon	8,255,026 B1	8/2012	Al-Ali
7,919,713 B2	4/2011	Al-Ali et al.	8,255,027 B2	8/2012	Al-Ali et al.
7,937,128 B2	5/2011	Al-Ali	8,255,028 B2	8/2012	Al-Ali et al.
7,937,129 B2	5/2011	Mason et al.	8,260,577 B2	9/2012	Weber et al.
7,937,130 B2	5/2011	Diab et al.	8,265,723 B1 *	9/2012	McHale et al. .... 600/310
7,941,199 B2	5/2011	Kiani	8,274,360 B2	9/2012	Sampath et al.
7,951,086 B2	5/2011	Flaherty et al.	8,294,588 B2 *	10/2012	Fisher et al. .... 340/636.1
7,957,780 B2	6/2011	Lamego et al.	8,294,716 B2	10/2012	Lord et al.
7,962,188 B2	6/2011	Kiani et al.	8,301,217 B2	10/2012	Al-Ali et al.
7,962,190 B1	6/2011	Diab et al.	8,306,596 B2	11/2012	Schurman et al.
7,963,927 B2	6/2011	Kelleher et al.	8,310,336 B2	11/2012	Muhsin et al.
7,967,749 B2	6/2011	Hutchinson et al.	8,311,747 B2	11/2012	Taylor
7,976,472 B2	7/2011	Kiani	8,311,748 B2	11/2012	Taylor et al.
7,988,637 B2	8/2011	Diab	8,315,683 B2	11/2012	Al-Ali et al.
7,988,639 B2	8/2011	Starks	8,315,812 B2	11/2012	Taylor
7,990,382 B2	8/2011	Kiani	8,315,813 B2	11/2012	Taylor et al.
7,991,446 B2	8/2011	Ali et al.	8,315,814 B2	11/2012	Taylor et al.
7,991,463 B2	8/2011	Kelleher et al.	8,321,004 B2	11/2012	Moon et al.
7,991,625 B2	8/2011	Rosenfeld	8,321,150 B2	11/2012	Taylor
7,993,275 B2	8/2011	Banet et al.	RE43,860 E	12/2012	Parker
8,000,761 B2	8/2011	Al-Ali	8,326,649 B2	12/2012	Rosenfeld
8,008,088 B2	8/2011	Bellott et al.	8,328,793 B2	12/2012	Birkenbach
RE42,753 E	9/2011	Kiani-Azarbayjany et al.	8,337,403 B2	12/2012	Al-Ali et al.
8,019,400 B2	9/2011	Diab et al.	8,346,330 B2	1/2013	Lamego
8,027,846 B2	9/2011	Schoenberg	8,353,842 B2	1/2013	Al-Ali et al.
8,028,701 B2	10/2011	Al-Ali et al.	8,355,766 B2	1/2013	MacNeish, III et al.
8,029,765 B2	10/2011	Bellott et al.	8,359,080 B2	1/2013	Diab et al.
8,033,996 B2	10/2011	Behar	8,360,936 B2	1/2013	Dibenedetto et al.
8,036,727 B2	10/2011	Schurman et al.	8,364,223 B2	1/2013	Al-Ali et al.
8,036,728 B2	10/2011	Diab et al.	8,364,226 B2	1/2013	Diab et al.
8,036,736 B2	10/2011	Snyder et al.	8,364,250 B2	1/2013	Moon et al.
8,038,625 B2	10/2011	Afonso et al.	8,374,665 B2	2/2013	Lamego
8,046,040 B2	10/2011	Ali et al.	8,385,995 B2	2/2013	Al-Ali et al.
			8,385,996 B2	2/2013	Smith et al.
			D679,018 S	3/2013	Fullerton et al.
			8,388,353 B2	3/2013	Kiani et al.
			8,399,822 B2	3/2013	Al-Ali

(56)

## References Cited

## U.S. PATENT DOCUMENTS

8,401,602 B2	3/2013	Kiani	8,670,814 B2	3/2014	Diab et al.
8,401,874 B2	3/2013	Rosenfeld	8,672,854 B2	3/2014	McCombie et al.
8,405,608 B2	3/2013	Al-Ali et al.	8,676,286 B2	3/2014	Weber et al.
8,414,499 B2	4/2013	Al-Ali et al.	8,682,407 B2	3/2014	Al-Ali
8,418,524 B2	4/2013	Al-Ali	RE44,823 E	4/2014	Parker
8,419,649 B2	4/2013	Banet et al.	RE44,875 E	4/2014	Kiani et al.
8,423,106 B2	4/2013	Lamego et al.	8,690,771 B2	4/2014	Wekell et al.
8,428,967 B2	4/2013	Olsen et al.	8,690,799 B2	4/2014	Telfort et al.
8,430,817 B1	4/2013	Al-Ali et al.	8,700,112 B2	4/2014	Kiani
8,437,824 B2	5/2013	Moon et al.	8,702,627 B2	4/2014	Telfort et al.
8,437,825 B2	5/2013	Dalvi et al.	8,706,179 B2	4/2014	Parker
8,442,607 B2	5/2013	Banet et al.	8,712,494 B1	4/2014	MacNeish, III et al.
8,449,469 B2	5/2013	Banet et al.	8,715,206 B2	5/2014	Telfort et al.
8,455,290 B2	6/2013	Siskavich	8,718,735 B2	5/2014	Lamego et al.
8,457,703 B2	6/2013	Al-Ali	8,718,737 B2	5/2014	Diab et al.
8,457,707 B2	6/2013	Kiani	8,718,738 B2	5/2014	Blank et al.
8,463,349 B2	6/2013	Diab et al.	8,720,249 B2	5/2014	Al-Ali
8,466,286 B2	6/2013	Bellot et al.	8,721,541 B2	5/2014	Al-Ali et al.
8,471,713 B2	6/2013	Poeze et al.	8,721,542 B2	5/2014	Al-Ali et al.
8,473,020 B2	6/2013	Kiani et al.	8,723,677 B1	5/2014	Kiani
8,475,370 B2	7/2013	McCombie et al.	8,727,977 B2	5/2014	Banet et al.
8,483,787 B2	7/2013	Al-Ali et al.	8,738,118 B2	5/2014	Moon et al.
8,489,167 B2	7/2013	Buxton	8,740,792 B1	6/2014	Kiani et al.
8,489,364 B2	7/2013	Weber et al.	8,740,802 B2	6/2014	Banet et al.
8,498,684 B2	7/2013	Weber et al.	8,740,807 B2	6/2014	Banet et al.
8,504,128 B2	8/2013	Blank et al.	8,747,330 B2	6/2014	Banet et al.
8,506,480 B2	8/2013	Banet et al.	8,754,776 B2	6/2014	Poeze et al.
8,509,867 B2	8/2013	Workman et al.	8,755,535 B2	6/2014	Telfort et al.
8,515,509 B2	8/2013	Bruinsma et al.	8,755,856 B2	6/2014	Diab et al.
8,523,781 B2	9/2013	Al-Ali	8,755,872 B1	6/2014	Marinow
8,527,038 B2	9/2013	Moon et al.	8,761,850 B2	6/2014	Lamego
8,529,301 B2	9/2013	Al-Ali et al.	D709,846 S	7/2014	Oswaks
8,532,727 B2	9/2013	Ali et al.	8,764,671 B2	7/2014	Kiani
8,532,728 B2	9/2013	Diab et al.	8,768,423 B2	7/2014	Shakespeare et al.
D692,145 S	10/2013	Al-Ali et al.	8,771,204 B2	7/2014	Telfort et al.
8,545,417 B2	10/2013	Banet et al.	8,777,634 B2	7/2014	Kiani et al.
8,547,209 B2	10/2013	Kiani et al.	8,781,543 B2	7/2014	Diab et al.
8,548,548 B2	10/2013	Al-Ali	8,781,544 B2	7/2014	Al-Ali et al.
8,548,549 B2	10/2013	Schurman et al.	8,781,549 B2	7/2014	Al-Ali et al.
8,548,550 B2	10/2013	Al-Ali et al.	8,788,003 B2	7/2014	Schurman et al.
8,554,297 B2	10/2013	Moon et al.	8,790,268 B2	7/2014	Al-Ali
8,560,032 B2	10/2013	Al-Ali et al.	8,801,613 B2	8/2014	Al-Ali et al.
8,560,034 B1	10/2013	Diab et al.	8,808,188 B2	8/2014	Banet et al.
8,565,847 B2	10/2013	Buxton et al.	8,818,477 B2	8/2014	Soller
8,570,167 B2	10/2013	Al-Ali	8,821,397 B2	9/2014	Al-Ali et al.
8,570,503 B2	10/2013	Vo et al.	8,821,415 B2	9/2014	Al-Ali et al.
8,571,617 B2	10/2013	Reichgott et al.	8,830,449 B1	9/2014	Lamego et al.
8,571,618 B1	10/2013	Lamego et al.	8,831,700 B2	9/2014	Schurman et al.
8,571,619 B2	10/2013	Al-Ali et al.	8,840,549 B2	9/2014	Al-Ali et al.
8,584,345 B2	10/2013	Al-Ali et al.	8,847,740 B2	9/2014	Kiani et al.
8,574,161 B2	11/2013	Banet et al.	8,849,365 B2	9/2014	Smith et al.
8,577,431 B2	11/2013	Lamego et al.	8,852,094 B2	10/2014	Al-Ali et al.
8,578,082 B2	11/2013	Medina et al.	8,852,994 B2	10/2014	Wojtczuk et al.
8,579,813 B2	11/2013	Causey	8,866,620 B2	10/2014	Amir
8,581,732 B2	11/2013	Al-Ali et al.	8,868,147 B2	10/2014	Stippick et al.
8,588,880 B2	11/2013	Abdul-Hafiz et al.	8,868,150 B2	10/2014	Al-Ali et al.
8,588,924 B2*	11/2013	Dion ..... 607/60	8,870,792 B2	10/2014	Al-Ali et al.
8,591,411 B2	11/2013	Banet et al.	8,873,035 B2	10/2014	Yang et al.
8,594,776 B2	11/2013	McCombie et al.	8,878,888 B2	11/2014	Rosenfeld
8,597,287 B2	12/2013	Benamou et al.	8,886,271 B2	11/2014	Kiani et al.
8,600,467 B2	12/2013	Al-Ali et al.	8,888,539 B2	11/2014	Al-Ali et al.
8,600,777 B2	12/2013	Schoenberg	8,888,700 B2	11/2014	Banet et al.
8,602,997 B2	12/2013	Banet et al.	8,888,708 B2	11/2014	Diab et al.
8,606,342 B2	12/2013	Diab	8,892,180 B2	11/2014	Weber et al.
8,620,678 B2	12/2013	Gotlib	8,897,847 B2	11/2014	Al-Ali
8,622,922 B2	1/2014	Banet et al.	8,907,287 B2	12/2014	Vanderpohl
8,626,255 B2	1/2014	Al-Ali et al.	8,909,310 B2	12/2014	Lamego et al.
8,630,691 B2	1/2014	Lamego et al.	8,909,330 B2	12/2014	McCombie et al.
8,634,889 B2	1/2014	Al-Ali et al.	8,911,377 B2	12/2014	Al-Ali
8,641,631 B2	2/2014	Sierra et al.	8,912,909 B2	12/2014	Al-Ali et al.
8,652,060 B2	2/2014	Al-Ali	8,920,317 B2	12/2014	Al-Ali et al.
8,663,107 B2	3/2014	Kiani	8,921,699 B2	12/2014	Al-Ali et al.
8,666,468 B1	3/2014	Al-Ali	8,922,382 B2	12/2014	Al-Ali et al.
8,667,967 B2	3/2014	Al-Ali et al.	8,929,964 B2	1/2015	Al-Ali et al.
8,670,811 B2	3/2014	O'Reilly	8,942,777 B2	1/2015	Diab et al.
			8,948,834 B2	2/2015	Diab et al.
			8,948,835 B2	2/2015	Diab
			8,951,248 B2	2/2015	Messerly et al.
			8,956,292 B2	2/2015	Wekell et al.

(56)

References Cited

U.S. PATENT DOCUMENTS

8,956,293 B2	2/2015	McCombie et al.	9,351,675 B2	5/2016	Al-Ali et al.
8,956,294 B2	2/2015	McCombie et al.	9,364,158 B2	6/2016	Banet et al.
8,965,471 B2	2/2015	Lamego	9,364,181 B2	6/2016	Kiani et al.
8,979,765 B2	3/2015	Banet et al.	9,368,671 B2	6/2016	Wojtczuk et al.
8,983,564 B2	3/2015	Al-Ali	9,370,325 B2	6/2016	Al-Ali et al.
8,989,831 B2	3/2015	Al-Ali et al.	9,370,326 B2	6/2016	McHale et al.
8,996,085 B2	3/2015	Kiani et al.	9,370,335 B2	6/2016	Al-Ali et al.
8,998,809 B2	4/2015	Kiani	9,375,185 B2	6/2016	Ali et al.
9,028,429 B2	5/2015	Telfort et al.	9,380,952 B2	7/2016	Banet et al.
9,037,207 B2	5/2015	Al-Ali et al.	9,386,953 B2	7/2016	Al-Ali
9,055,928 B2	6/2015	McCombie et al.	9,386,961 B2	7/2016	Al-Ali et al.
9,057,689 B2	6/2015	Soller	9,392,945 B2	7/2016	Al-Ali et al.
9,060,721 B2	6/2015	Reichgott et al.	9,397,448 B2	7/2016	Al-Ali et al.
9,066,666 B2	6/2015	Kiani	9,408,573 B2	8/2016	Welch et al.
9,066,680 B1	6/2015	Al-Ali et al.	9,436,645 B2	9/2016	Al-Ali et al.
9,072,474 B2	7/2015	Al-Ali et al.	9,439,574 B2	9/2016	McCombie et al.
9,078,560 B2	7/2015	Schurman et al.	9,529,762 B2	12/2016	Gisler et al.
9,084,569 B2	7/2015	Weber et al.	2001/0011355 A1 *	8/2001	Kawai ..... 713/202
9,095,291 B2	8/2015	Soller	2001/0031922 A1	10/2001	Weng et al.
9,095,316 B2	8/2015	Welch et al.	2001/0046366 A1	11/2001	Susskind
9,104,789 B2	8/2015	Gross et al.	2002/0045836 A1	4/2002	Alkawwas
9,106,038 B2	8/2015	Telfort et al.	2002/0052311 A1	5/2002	Solomon et al.
9,107,625 B2	8/2015	Telfort et al.	2002/0063690 A1	5/2002	Chung et al.
9,107,626 B2	8/2015	Al-Ali et al.	2002/0140675 A1	10/2002	Ali et al.
9,113,831 B2	8/2015	Al-Ali	2002/0177758 A1	11/2002	Schoenberg
9,113,832 B2	8/2015	Al-Ali	2002/0198445 A1	12/2002	Dominguez et al.
9,119,595 B2	9/2015	Lamego	2003/0027326 A1	2/2003	Ulmsten et al.
9,131,881 B2	9/2015	Diab et al.	2003/0052787 A1	3/2003	Zerhusen et al.
9,131,882 B2	9/2015	Al-Ali et al.	2003/0058838 A1	3/2003	Wengrovitz
9,131,883 B2	9/2015	Al-Ali	2003/0158466 A1	8/2003	Lynn et al.
9,131,917 B2	9/2015	Telfort et al.	2003/0216670 A1	11/2003	Beggs
9,138,180 B1	9/2015	Coverston et al.	2004/0013647 A1	1/2004	Solomon et al.
9,138,182 B2	9/2015	Al-Ali et al.	2004/0073095 A1	4/2004	Causey et al.
9,138,192 B2	9/2015	Weber et al.	2004/0090742 A1	5/2004	Son et al.
9,142,117 B2	9/2015	Muhsin et al.	2004/0122787 A1	6/2004	Avinash et al.
9,149,192 B2	10/2015	Banet et al.	2004/0126007 A1	7/2004	Ziel et al.
9,153,112 B1	10/2015	Kiani et al.	2004/0139571 A1	7/2004	Chang et al.
9,153,121 B2	10/2015	Kiani et al.	2004/0147818 A1	7/2004	Levy et al.
9,161,696 B2	10/2015	Al-Ali et al.	2004/0152957 A1	8/2004	Stivoric et al.
9,161,700 B2	10/2015	Banet et al.	2004/0179332 A1	9/2004	Smith et al.
9,161,713 B2	10/2015	Al-Ali et al.	2004/0186357 A1	9/2004	Soderberg et al.
9,167,995 B2	10/2015	Lamego et al.	2004/0230118 A1	11/2004	Shehada et al.
9,173,593 B2	11/2015	Banet et al.	2004/0230132 A1	11/2004	Shehada et al.
9,173,594 B2	11/2015	Banet et al.	2004/0230179 A1	11/2004	Shehada et al.
9,176,141 B2	11/2015	Al-Ali et al.	2004/0243017 A1	12/2004	Causevic
9,186,102 B2	11/2015	Bruinsma et al.	2004/0249670 A1	12/2004	Noguchi et al.
9,192,312 B2	11/2015	Al-Ali	2004/0254431 A1	12/2004	Shehada et al.
9,192,329 B2	11/2015	Al-Ali	2004/0254432 A1	12/2004	Shehada et al.
9,192,351 B1	11/2015	Telfort et al.	2004/0267103 A1	12/2004	Li et al.
9,195,385 B2	11/2015	Al-Ali et al.	2005/0005710 A1	1/2005	Sage, Jr.
D745,167 S	12/2015	Canas et al.	2005/0009926 A1	1/2005	Kreye et al.
9,211,072 B2	12/2015	Kiani	2005/0020918 A1	1/2005	Wilk et al.
9,211,095 B1	12/2015	Al-Ali	2005/0038332 A1	2/2005	Saidara et al.
9,215,986 B2	12/2015	Banet et al.	2005/0038680 A1	2/2005	McMahon
9,218,454 B2	12/2015	Kiani et al.	2005/0065417 A1 *	3/2005	Ali et al. .... 600/323
9,226,696 B2	1/2016	Kiani	2005/0080336 A1	4/2005	Byrd et al.
9,241,662 B2	1/2016	Al-Ali et al.	2005/0096542 A1	5/2005	Weng et al.
9,245,668 B1	1/2016	Vo et al.	2005/0113653 A1	5/2005	Fox et al.
9,259,185 B2	2/2016	Abdul-Hafiz et al.	2005/0124864 A1	6/2005	Mack et al.
9,262,586 B2	2/2016	Steiger et al.	2005/0125256 A1	6/2005	Schoenberg
9,267,572 B2	2/2016	Barker et al.	2005/0148882 A1	7/2005	Banet et al.
9,277,880 B2	3/2016	Poeze et al.	2005/0164933 A1	7/2005	Tymianski et al.
9,289,167 B2	3/2016	Diab et al.	2005/0191294 A1	9/2005	Arap et al.
9,295,421 B2	3/2016	Kiani et al.	2005/0208648 A1	9/2005	Sage, Jr. et al.
9,307,915 B2	4/2016	McCombie et al.	2005/0209518 A1	9/2005	Sage, Jr. et al.
9,307,928 B1	4/2016	Al-Ali et al.	2005/0228244 A1	10/2005	Banet
9,323,894 B2	4/2016	Kiani	2005/0228299 A1	10/2005	Banet
D755,392 S	5/2016	Hwang et al.	2005/0242946 A1	11/2005	Hubbard, Jr. et al.
9,326,712 B1	5/2016	Kiani	2005/0245831 A1	11/2005	Banet
9,333,316 B2	5/2016	Kiani	2005/0261594 A1	11/2005	Banet
9,339,209 B2	5/2016	Banet et al.	2005/0261598 A1	11/2005	Banet et al.
9,339,211 B2	5/2016	Banet et al.	2005/0268401 A1	12/2005	Dixon et al.
9,339,220 B2	5/2016	Lamego et al.	2005/0277872 A1	12/2005	Colby et al.
9,341,565 B2	5/2016	Lamego et al.	2006/0009697 A1	1/2006	Banet et al.
9,351,673 B2	5/2016	Diab et al.	2006/0009698 A1	1/2006	Banet et al.
			2006/0049936 A1	3/2006	Collins, Jr. et al.
			2006/0058647 A1	3/2006	Strommer et al.
			2006/0084878 A1	4/2006	Banet et al.
			2006/0089543 A1	4/2006	Kim et al.

(56)

## References Cited

## U.S. PATENT DOCUMENTS

2006/0094936	A1	5/2006	Russ	2008/0312542	A1	12/2008	Banet et al.
2006/0149393	A1	7/2006	Calderon	2008/0319275	A1	12/2008	Chiu et al.
2006/0155175	A1	7/2006	Ogino et al.	2008/0319327	A1	12/2008	Banet et al.
2006/0200009	A1	9/2006	Wekell et al.	2008/0319354	A1	12/2008	Bell et al.
2006/0217684	A1	9/2006	Shehada et al.	2009/0005651	A1	1/2009	Ward et al.
2006/0217685	A1	9/2006	Shehada et al.	2009/0018422	A1	1/2009	Banet et al.
2006/0224413	A1	10/2006	Kim et al.	2009/0018453	A1	1/2009	Banet et al.
2006/0235300	A1	10/2006	Weng et al.	2009/0018808	A1	1/2009	Bronstein et al.
2006/0253042	A1	11/2006	Stahmann et al.	2009/0024008	A1	1/2009	Brunner et al.
2007/0000490	A1	1/2007	DeVries et al.	2009/0043172	A1	2/2009	Zagorchev et al.
2007/0002533	A1	1/2007	Kogan et al.	2009/0052623	A1	2/2009	Tome et al.
2007/0021675	A1	1/2007	Childre et al.	2009/0054735	A1	2/2009	Higgins et al.
2007/0027368	A1	2/2007	Collins et al.	2009/0054743	A1	2/2009	Stewart
2007/0032733	A1	2/2007	Burton et al.	2009/0062682	A1	3/2009	Bland et al.
2007/0055116	A1	3/2007	Clark et al.	2009/0069642	A1	3/2009	Gao et al.
2007/0055544	A1	3/2007	Jung et al.	2009/0099480	A1	4/2009	Salgo et al.
2007/0060798	A1	3/2007	Krupnik et al.	2009/0112072	A1	4/2009	Banet et al.
2007/0088406	A1	4/2007	Bennett et al.	2009/0118628	A1	5/2009	Zhou et al.
2007/0096897	A1*	5/2007	Weiner ..... 340/539.13	2009/0119330	A1	5/2009	Sampath et al.
2007/0100222	A1*	5/2007	Mastrototaro et al. .... 600/365	2009/0119843	A1	5/2009	Rodgers et al.
2007/0118399	A1	5/2007	Avinash et al.	2009/0124867	A1	5/2009	Hirsch et al.
2007/0140475	A1	6/2007	Kurtock et al.	2009/0131759	A1	5/2009	Sims et al.
2007/0142715	A1	6/2007	Banet et al.	2009/0143832	A1	6/2009	Saba
2007/0156033	A1	7/2007	Causey et al.	2009/0157058	A1	6/2009	Ferren et al.
2007/0157285	A1	7/2007	Frank et al.	2009/0171170	A1	7/2009	Li et al.
2007/0159332	A1	7/2007	Koblasz	2009/0171225	A1	7/2009	Gadodia et al.
2007/0163589	A1	7/2007	DeVries et al.	2009/0177090	A1	7/2009	Grunwald et al.
2007/0185390	A1	8/2007	Perkins et al.	2009/0182287	A1	7/2009	Kassab
2007/0185393	A1	8/2007	Zhou et al.	2009/0226372	A1	9/2009	Ruoslahti et al.
2007/0232941	A1	10/2007	Rabinovich	2009/0247924	A1	10/2009	Lamego et al.
2007/0244724	A1	10/2007	Pendergast et al.	2009/0247984	A1	10/2009	Lamego et al.
2007/0254593	A1*	11/2007	Jollota et al. .... 455/67.11	2009/0264778	A1	10/2009	Markowitz et al.
2007/0255114	A1	11/2007	Ackermann et al.	2009/0275813	A1	11/2009	Davis
2007/0255116	A1*	11/2007	Mehta et al. .... 600/300	2009/0275844	A1	11/2009	Al-Ali
2007/0255250	A1	11/2007	Moberg	2009/0281462	A1	11/2009	Heliot et al.
2007/0276261	A1	11/2007	Banet et al.	2009/0299157	A1	12/2009	Telfort et al.
2007/0276262	A1	11/2007	Banet et al.	2009/0309755	A1*	12/2009	Williamson et al. .... 340/870.02
2007/0276632	A1	11/2007	Banet et al.	2009/0322540	A1	12/2009	Richardson et al.
2007/0282478	A1	12/2007	Al-Ali et al.	2010/0004518	A1	1/2010	Vo et al.
2008/0000479	A1	1/2008	Elaz et al.	2010/0030040	A1	2/2010	Poeze et al.
2008/0003200	A1	1/2008	Arap et al.	2010/0030094	A1	2/2010	Lundback
2008/0021854	A1	1/2008	Jung et al.	2010/0036209	A1	2/2010	Ferren et al.
2008/0033661	A1	2/2008	Syroid et al.	2010/0069725	A1	3/2010	Al-Ali
2008/0039701	A1	2/2008	Ali et al.	2010/0125217	A1	5/2010	Kuo et al.
2008/0051670	A1	2/2008	Banet et al.	2010/0130875	A1	5/2010	Banet et al.
2008/0053438	A1	3/2008	DeVries et al.	2010/0144627	A1	6/2010	Vitek et al.
2008/0058614	A1	3/2008	Banet et al.	2010/0160794	A1	6/2010	Banet et al.
2008/0058657	A1	3/2008	Schwartz et al.	2010/0160795	A1	6/2010	Banet et al.
2008/0082004	A1	4/2008	Banet et al.	2010/0160796	A1	6/2010	Banet et al.
2008/0090626	A1	4/2008	Griffin et al.	2010/0160797	A1	6/2010	Banet et al.
2008/0091089	A1	4/2008	Guillory et al.	2010/0160798	A1	6/2010	Banet et al.
2008/0091090	A1	4/2008	Guillory et al.	2010/0168536	A1	7/2010	Banet et al.
2008/0091471	A1	4/2008	Michon et al.	2010/0168589	A1	7/2010	Banet et al.
2008/0097167	A1	4/2008	Yudkovitch et al.	2010/0185101	A1	7/2010	Sakai et al.
2008/0099366	A1	5/2008	Niemiec et al.	2010/0198622	A1	8/2010	Gajic et al.
2008/0108884	A1	5/2008	Kiani	2010/0210958	A1	8/2010	Manwaring et al.
2008/0119412	A1	5/2008	Tymianski et al.	2010/0261979	A1	10/2010	Kiani
2008/0138278	A1	6/2008	Scherz et al.	2010/0298650	A1	11/2010	Moon et al.
2008/0169922	A1*	7/2008	Issokson ..... 340/541	2010/0298651	A1	11/2010	Moon et al.
2008/0171919	A1	7/2008	Stivoric et al.	2010/0298652	A1	11/2010	McCombie et al.
2008/0188795	A1	8/2008	Katz et al.	2010/0298653	A1	11/2010	McCombie et al.
2008/0194918	A1	8/2008	Kulik et al.	2010/0298654	A1	11/2010	McCombie et al.
2008/0208912	A1	8/2008	Garibaldi	2010/0298655	A1	11/2010	McCombie et al.
2008/0221396	A1	9/2008	Garces et al.	2010/0298656	A1	11/2010	McCombie et al.
2008/0221399	A1	9/2008	Zhou et al.	2010/0298657	A1	11/2010	McCombie et al.
2008/0221461	A1	9/2008	Zhou et al.	2010/0298658	A1	11/2010	McCombie et al.
2008/0228077	A1	9/2008	Wilk et al.	2010/0298659	A1	11/2010	McCombie et al.
2008/0275309	A1	11/2008	Stivoric et al.	2010/0298660	A1	11/2010	McCombie et al.
2008/0281167	A1	11/2008	Soderberg et al.	2010/0298661	A1	11/2010	McCombie et al.
2008/0281168	A1	11/2008	Gibson et al.	2010/0298742	A1	11/2010	Perlman et al.
2008/0281181	A1	11/2008	Manziona et al.	2010/0305412	A1	12/2010	Darrah et al.
2008/0287751	A1	11/2008	Stivoric et al.	2010/0312103	A1	12/2010	Gorek et al.
2008/0292172	A1	11/2008	Assmann et al.	2010/0317936	A1	12/2010	Al-Ali et al.
2008/0139354	A1	12/2008	Bell et al.	2010/0317951	A1	12/2010	Rutkowski et al.
2008/0300020	A1*	12/2008	Nishizawa et al. .... 455/558	2010/0324384	A1	12/2010	Moon et al.
				2010/0324385	A1	12/2010	Moon et al.
				2010/0324386	A1	12/2010	Moon et al.
				2010/0324387	A1	12/2010	Moon et al.
				2010/0324388	A1	12/2010	Moon et al.

(56)

## References Cited

## U.S. PATENT DOCUMENTS

2010/0324389	A1	12/2010	Moon et al.	2012/0179006	A1	7/2012	Jansen et al.
2011/0001605	A1	1/2011	Kiani et al.	2012/0179011	A1	7/2012	Moon et al.
2011/0021930	A1	1/2011	Mazzeo et al.	2012/0184120	A1	7/2012	Basta et al.
2011/0023130	A1	1/2011	Gudgel et al.	2012/0190949	A1	7/2012	McCombie et al.
2011/0028809	A1	2/2011	Goodman	2012/0197619	A1	8/2012	Namer Yelin et al.
2011/0046495	A1	2/2011	Osypka	2012/0203078	A1	8/2012	Sze et al.
2011/0066051	A1	3/2011	Moon et al.	2012/0209082	A1	8/2012	Al-Ali
2011/0077473	A1	3/2011	Lisogurski	2012/0209084	A1	8/2012	Olsen et al.
2011/0077488	A1	3/2011	Buxton et al.	2012/0226160	A1	9/2012	Kudoh
2011/0078596	A1	3/2011	Rawlins et al.	2012/0227739	A1	9/2012	Kiani
2011/0080294	A1	4/2011	Tanishima et al.	2012/0239434	A1	9/2012	Breslow et al.
2011/0082711	A1	4/2011	Poeze et al.	2012/0242501	A1	9/2012	Tran et al.
2011/0087083	A1	4/2011	Poeze et al.	2012/0265039	A1	10/2012	Kiani
2011/0087084	A1	4/2011	Jeong et al.	2012/0282583	A1	11/2012	Thaler et al.
2011/0087117	A1	4/2011	Tremper et al.	2012/0283524	A1	11/2012	Kiani et al.
2011/0087756	A1	4/2011	Biondi	2012/0284053	A1	11/2012	Rosenfeld
2011/0098583	A1	4/2011	Pandia et al.	2012/0286955	A1	11/2012	Welch et al.
2011/0105854	A1	5/2011	Kiani et al.	2012/0294801	A1	11/2012	Scherz et al.
2011/0105956	A1	5/2011	Hirth	2012/0296178	A1	11/2012	Lamego et al.
2011/0118573	A1	5/2011	Mckenna	2012/0302894	A1	11/2012	Diab et al.
2011/0125060	A1	5/2011	Telfort et al.	2012/0303476	A1	11/2012	Krzyzanowski et al.
2011/0152629	A1	6/2011	Eaton et al.	2012/0319816	A1	12/2012	Al-Ali
2011/0172967	A1	7/2011	Al-Ali et al.	2012/0330112	A1	12/2012	Lamego et al.
2011/0184252	A1	7/2011	Archer et al.	2013/0006131	A1	1/2013	Narayan et al.
2011/0184253	A1	7/2011	Archer et al.	2013/0006151	A1	1/2013	Main et al.
2011/0208015	A1	8/2011	Welch et al.	2013/0023775	A1	1/2013	Lamego et al.
2011/0208018	A1	8/2011	Kiani	2013/0035603	A1	2/2013	Jarausch et al.
2011/0208073	A1	8/2011	Matsukawa et al.	2013/0045685	A1	2/2013	Kiani
2011/0209915	A1	9/2011	Telfort et al.	2013/0046197	A1	2/2013	Dlugos et al.
2011/0212090	A1	9/2011	Pedersen et al.	2013/0046204	A1	2/2013	Lamego et al.
2011/0213212	A1	9/2011	Al-Ali	2013/0041591	A1	3/2013	Lamego
2011/0224498	A1	9/2011	Banet et al.	2013/0060108	A1	3/2013	Schurman et al.
2011/0224499	A1	9/2011	Banet et al.	2013/0060147	A1	3/2013	Welch et al.
2011/0224500	A1	9/2011	Banet et al.	2013/0079610	A1	3/2013	Al-Ali
2011/0224506	A1	9/2011	Moon et al.	2013/0092805	A1	4/2013	Funk et al.
2011/0224507	A1	9/2011	Banet et al.	2013/0096405	A1	4/2013	Garfio
2011/0224508	A1	9/2011	Moon et al.	2013/0096936	A1	4/2013	Sampath et al.
2011/0224556	A1	9/2011	Moon et al.	2013/0109929	A1	5/2013	Menzel
2011/0224557	A1	9/2011	Banet et al.	2013/0109935	A1	5/2013	Al-Ali et al.
2011/0224564	A1	9/2011	Moon et al.	2013/0109937	A1	5/2013	Banet et al.
2011/0227739	A1	9/2011	Gilham et al.	2013/0116515	A1	5/2013	Banet et al.
2011/0230733	A1	9/2011	Al-Ali	2013/0123616	A1	5/2013	Merritt et al.
2011/0237911	A1	9/2011	Lamego et al.	2013/0162433	A1	6/2013	Muhsin et al.
2011/0237969	A1	9/2011	Eckerbom et al.	2013/0178749	A1	7/2013	Lamego
2011/0257489	A1	10/2011	Banet et al.	2013/0190581	A1	7/2013	Al-Ali et al.
2011/0257544	A1	10/2011	Kaasinen et al.	2013/0197328	A1	8/2013	Diab et al.
2011/0257551	A1	10/2011	Banet et al.	2013/0197364	A1	8/2013	Han
2011/0257552	A1	10/2011	Banet et al.	2013/0211214	A1	8/2013	Olsen
2011/0257553	A1	10/2011	Banet et al.	2013/0243021	A1	9/2013	Siskavich
2011/0257554	A1	10/2011	Banet et al.	2013/0253334	A1	9/2013	Al-Ali et al.
2011/0257555	A1	10/2011	Banet et al.	2013/0261494	A1	10/2013	Bloom et al.
2011/0263950	A1	10/2011	Larson et al.	2013/0262730	A1	10/2013	Al-Ali et al.
2011/0288383	A1	11/2011	Diab	2013/0267804	A1	10/2013	Al-Ali
2011/0288421	A1	11/2011	Banet et al.	2013/0274571	A1	10/2013	Diab et al.
2011/0295094	A1	12/2011	Doyle et al.	2013/0274572	A1	10/2013	Al-Ali et al.
2011/0301444	A1	12/2011	Al-Ali	2013/0279109	A1	10/2013	Lindblad et al.
2012/0004579	A1	1/2012	Luo et al.	2013/0296672	A1	11/2013	O'Neil et al.
2012/0029300	A1	2/2012	Paquet	2013/0296713	A1	11/2013	Al-Ali et al.
2012/0029304	A1	2/2012	Medina et al.	2013/0317327	A1	11/2013	Al-Ali et al.
2012/0029879	A1	2/2012	Sing et al.	2013/0317370	A1	11/2013	Dalvi et al.
2012/0041316	A1	2/2012	Al-Ali et al.	2013/0317393	A1	11/2013	Weiss et al.
2012/0046557	A1	2/2012	Kiani	2013/0324804	A1	12/2013	McKeown et al.
2012/0059230	A1	3/2012	Teller et al.	2013/0324808	A1	12/2013	Al-Ali et al.
2012/0059267	A1	3/2012	Lamego et al.	2013/0324817	A1	12/2013	Diab
2012/0071771	A1	3/2012	Behar	2013/0331660	A1	12/2013	Al-Ali et al.
2012/0075464	A1	3/2012	Derenne et al.	2013/0331670	A1	12/2013	Kiani
2012/0088984	A1	4/2012	Al-Ali et al.	2013/0338461	A1	12/2013	Lamego et al.
2012/0095778	A1	4/2012	Gross et al.	2013/0340176	A1	12/2013	Stevens et al.
2012/0101353	A1	4/2012	Reggiardo et al.	2014/0012100	A1	1/2014	Al-Ali et al.
2012/0108983	A1	5/2012	Banet et al.	2014/0022081	A1	1/2014	Ribble et al.
2012/0116175	A1	5/2012	Al-Ali et al.	2014/0025010	A1	1/2014	Stroup et al.
2012/0123799	A1	5/2012	Nolen et al.	2014/0025306	A1	1/2014	Weber et al.
2012/0136221	A1	5/2012	Killen et al.	2014/0031650	A1	1/2014	Weber et al.
2012/0157806	A1	6/2012	Stelger	2014/0034353	A1	2/2014	Al-Ali et al.
2012/0165629	A1	6/2012	Merritt et al.	2014/0046674	A1	2/2014	Rosenfeld
				2014/0051952	A1	2/2014	Reichgott et al.
				2014/0051953	A1	2/2014	Lamego et al.
				2014/0051954	A1	2/2014	Al-Ali et al.
				2014/0058230	A1	2/2014	Abdul-Hafiz et al.

(56)

## References Cited

## U.S. PATENT DOCUMENTS

2014/0066783	A1	3/2014	Kiani et al.	2014/0323825	A1	10/2014	Al-Ali et al.
2014/0073167	A1	3/2014	Al-Ali et al.	2014/0323897	A1	10/2014	Brown et al.
2014/0077956	A1	3/2014	Sampath et al.	2014/0323898	A1	10/2014	Purdon et al.
2014/0081097	A1	3/2014	Al-Ali et al.	2014/0330092	A1	11/2014	Al-Ali et al.
2014/0081099	A1	3/2014	Banet et al.	2014/0330098	A1	11/2014	Merritt et al.
2014/0081100	A1	3/2014	Muhsin et al.	2014/0330099	A1	11/2014	Al-Ali et al.
2014/0081175	A1	3/2014	Telfort	2014/0333440	A1	11/2014	Kiani
2014/0088385	A1	3/2014	Moon et al.	2014/0336481	A1	11/2014	Shakespeare et al.
2014/0094667	A1	4/2014	Schurman et al.	2014/0343436	A1	11/2014	Kiani
2014/0100434	A1	4/2014	Diab et al.	2014/0343889	A1	11/2014	Ben Shalom et al.
2014/0114199	A1	4/2014	Lamego et al.	2014/0357966	A1	12/2014	Al-Ali
2014/0120564	A1	5/2014	Workman et al.	2014/0371548	A1	12/2014	Al-Ali et al.
2014/0121482	A1	5/2014	Merritt et al.	2014/0371632	A1	12/2014	Al-Ali et al.
2014/0121483	A1	5/2014	Kiani	2014/0378784	A1	12/2014	Kiani et al.
2014/0125495	A1	5/2014	Al-Ali	2015/0005600	A1	1/2015	Blank et al.
2014/0127137	A1	5/2014	Bellott et al.	2015/0011907	A1	1/2015	Purdon et al.
2014/0128696	A1	5/2014	Al-Ali	2015/0012231	A1	1/2015	Poeze et al.
2014/0128699	A1	5/2014	Al-Ali et al.	2015/0018650	A1	1/2015	Al-Ali et al.
2014/0129702	A1	5/2014	Lamego et al.	2015/0025406	A1	1/2015	Al-Ali
2014/0135588	A1	5/2014	Al-Ali et al.	2015/0032029	A1	1/2015	Al-Ali et al.
2014/0142399	A1	5/2014	Al-Ali et al.	2015/0038859	A1	2/2015	Dalvi et al.
2014/0142401	A1	5/2014	Al-Ali et al.	2015/0045637	A1	2/2015	Dalvi
2014/0142402	A1	5/2014	Al-Ali et al.	2015/0051462	A1	2/2015	Olsen
2014/0142445	A1	5/2014	Banet et al.	2015/0080754	A1	3/2015	Purdon et al.
2014/0152673	A1	6/2014	Lynn et al.	2015/0087936	A1	3/2015	Al-Ali et al.
2014/0155712	A1	6/2014	Lamego et al.	2015/0094546	A1	4/2015	Al-Ali
2014/0163344	A1	6/2014	Al-Ali	2015/0094618	A1	4/2015	Russell et al.
2014/0163393	A1	6/2014	McCombie et al.	2015/0097701	A1	4/2015	Al-Ali et al.
2014/0163402	A1	6/2014	Lamego et al.	2015/0099950	A1	4/2015	Al-Ali et al.
2014/0166076	A1	6/2014	Kiani et al.	2015/0099951	A1	4/2015	Al-Ali et al.
2014/0171763	A1	6/2014	Diab	2015/0099955	A1	4/2015	Al-Ali et al.
2014/0180038	A1	6/2014	Kiani	2015/0101844	A1	4/2015	Al-Ali et al.
2014/0180154	A1	6/2014	Sierra et al.	2015/0106121	A1	4/2015	Muhsin et al.
2014/0180160	A1	6/2014	Brown et al.	2015/0112151	A1	4/2015	Muhsin et al.
2014/0187973	A1	7/2014	Brown et al.	2015/0116076	A1	4/2015	Al-Ali et al.
2014/0188516	A1	7/2014	Kamen	2015/0126830	A1	5/2015	Schurman et al.
2014/0194709	A1	7/2014	Al-Ali et al.	2015/0133755	A1	5/2015	Smith et al.
2014/0194711	A1	7/2014	Al-Ali	2015/0140863	A1	5/2015	Al-Ali et al.
2014/0194766	A1	7/2014	Al-Ali et al.	2015/0141781	A1	5/2015	Weber et al.
2014/0200415	A1	7/2014	McCombie et al.	2015/0164437	A1	6/2015	McCombie et al.
2014/0200420	A1	7/2014	Al-Ali	2015/0165312	A1	6/2015	Kiani
2014/0200422	A1	7/2014	Weber et al.	2015/0196237	A1	7/2015	Lamego
2014/0206963	A1	7/2014	Al-Ali	2015/0201874	A1	7/2015	Diab
2014/0213864	A1	7/2014	Abdul-Hafiz et al.	2015/0208966	A1	7/2015	Al-Ali
2014/0235964	A1	8/2014	Banet et al.	2015/0216459	A1	8/2015	Al-Ali et al.
2014/0243627	A1	8/2014	Diab et al.	2015/0230755	A1	8/2015	Al-Ali et al.
2014/0249431	A1	9/2014	Banet et al.	2015/0238722	A1	8/2015	Al-Ali
2014/0249432	A1	9/2014	Banet et al.	2015/0245773	A1	9/2015	Lamego et al.
2014/0249433	A1	9/2014	Banet et al.	2015/0245794	A1	9/2015	Al-Ali
2014/0249434	A1	9/2014	Banet et al.	2015/0257689	A1	9/2015	Al-Ali et al.
2014/0249435	A1	9/2014	Banet et al.	2015/0272514	A1	10/2015	Kiani et al.
2014/0249440	A1	9/2014	Banet et al.	2015/0282717	A1	10/2015	McCombie et al.
2014/0249441	A1	9/2014	Banet et al.	2015/0351697	A1	12/2015	Weber et al.
2014/0249442	A1	9/2014	Banet et al.	2015/0351704	A1	12/2015	Kiani et al.
2014/0257056	A1	9/2014	Moon et al.	2015/0359429	A1	12/2015	Al-Ali et al.
2014/0257057	A1	9/2014	Reis Cunha et al.	2015/0366472	A1	12/2015	Kiani
2014/0266787	A1	9/2014	Tran	2015/0366507	A1	12/2015	Blank
2014/0266790	A1	9/2014	Al-Ali et al.	2015/0374298	A1	12/2015	Al-Ali et al.
2014/0275808	A1	9/2014	Poeze et al.	2015/0380875	A1	12/2015	Coverston et al.
2014/0275835	A1	9/2014	Lamego et al.	2016/0000362	A1	1/2016	Diab et al.
2014/0275871	A1	9/2014	Lamego et al.	2016/0007930	A1	1/2016	Weber et al.
2014/0275872	A1	9/2014	Merritt et al.	2016/0022224	A1	1/2016	Banet et al.
2014/0275881	A1	9/2014	Lamego et al.	2016/0029932	A1	2/2016	Al-Ali
2014/0276115	A1	9/2014	Dalvi et al.	2016/0029933	A1	2/2016	Al-Ali et al.
2014/0276145	A1	9/2014	Banet et al.	2016/0045118	A1	2/2016	Kiani
2014/0276175	A1	9/2014	Banet et al.	2016/0045163	A1	2/2016	Weisner et al.
2014/0288400	A1	9/2014	Diab et al.	2016/0051205	A1	2/2016	Al-Ali et al.
2014/0296664	A1	10/2014	Bruinsma et al.	2016/0058338	A1	3/2016	Schurman et al.
2014/0301893	A1	10/2014	Stroup et al.	2016/0058347	A1	3/2016	Reichgott et al.
2014/0303520	A1	10/2014	Telfort et al.	2016/0066823	A1	3/2016	Al-Ali et al.
2014/0309506	A1	10/2014	Lamego et al.	2016/0066824	A1	3/2016	Al-Ali et al.
2014/0309559	A1	10/2014	Telfort et al.	2016/0066879	A1	3/2016	Telfort et al.
2014/0316217	A1	10/2014	Purdon et al.	2016/0072429	A1	3/2016	Kiani et al.
2014/0316218	A1	10/2014	Purdon et al.	2016/0073967	A1	3/2016	Lamego et al.
2014/0316228	A1	10/2014	Blank et al.	2016/0081552	A1	3/2016	Wojtczuk et al.
				2016/0095543	A1	4/2016	Telfort et al.
				2016/0095548	A1	4/2016	Al-Ali et al.
				2016/0103598	A1	4/2016	Al-Ali et al.
				2016/0113527	A1	4/2016	Al-Ali

(56)

**References Cited**

## U.S. PATENT DOCUMENTS

2016/0143546 A1 5/2016 McCombie et al.  
 2016/0143548 A1 5/2016 Al-Ali  
 2016/0166183 A1 6/2016 Poeze et al.  
 2016/0166188 A1 6/2016 Bruinsma et al.  
 2016/0166210 A1 6/2016 Al-Ali  
 2016/0192869 A1 7/2016 Kiani et al.  
 2016/0196388 A1 7/2016 Lamego  
 2016/0197436 A1 7/2016 Barker et al.  
 2016/0213281 A1 7/2016 Eckerbom et al.  
 2016/0324486 A1 11/2016 Al-Ali et al.  
 2016/0327984 A1 11/2016 Al-Ali et al.  
 2016/0328528 A1 11/2016 Al-Ali et al.

## FOREIGN PATENT DOCUMENTS

EP 2766834 8/2014  
 EP 2811894 12/2014  
 JP 10-336064 12/1998  
 JP 2002-513602 5/2002  
 JP 2002-165764 6/2002  
 JP 2002-172096 6/2002  
 JP 2002-542493 12/2002  
 JP 2005-218036 8/2005  
 JP 2005-295375 10/2005  
 JP 2007-021213 2/2007  
 JP 2007-095365 4/2007  
 JP 2007-174051 7/2007  
 JP 2008-519635 6/2008  
 JP 2008-541045 11/2008  
 JP 2009-017959 1/2009  
 JP 2009-207836 9/2009  
 JP 2010-503134 1/2010  
 JP 2010-524510 7/2010  
 JP 2011-519607 7/2011  
 JP 2011-152261 8/2011  
 JP 2014/533997 12/2014  
 JP 2016-538015 12/2016  
 WO WO 98/29790 7/1998  
 WO WO 99/13766 3/1999  
 WO WO 2004/056266 7/2004  
 WO WO 2004/059551 7/2004  
 WO WO 2011/001302 1/2011  
 WO WO 2011/002904 1/2011

WO WO 2011/025549 3/2011  
 WO WO 2013/056160 4/2013  
 WO WO 2013/119982 8/2013  
 WO WO 2015/054665 4/2015

## OTHER PUBLICATIONS

International Search Report and Written Opinion for PCT/US2013/025384 dated Aug. 6, 2013 in 18 pages.  
 Capuano et al. "Remote Telemetry—New Twists for Old Technology." *Nursing Management*. vol. 26, No. 7. Jul. 1995.  
 Elmer-Dewitt, Philip, Apple's iWatch: The killer apps may be in hospitals, not health clubs, *Fortune.com*, Feb. 3, 2014, <http://fortune.com/2014/02/03/apples-iwatch-the-killer-apps-may-be-in-hospitals-not-health-clubs/>, in 4 pages.  
 EP Office Action dated Jun. 15, 2015. EP App. No. 10195398.2.  
 Extended European Search Report for European Application No. 10195398.2 dated Jul. 5, 2012.  
 Grundy et al. "Telemedicine in Critical Care: An Experiment in Health Care Delivery." Oct. 1977.  
 Grundy et al. "Telemedicine in Critical Care: Problems in design, implementation and assessment." vol. 10, No. 7. Jul. 1982.  
 PCT International Preliminary Report on Patentability for Application No. PCT/US2012/060109, dated Apr. 24, 2014.  
 PCT International Search Report & Written Opinion, App. No. PCT/US2012/060109, dated Jun. 5, 2013.  
 PCT International Search Report & Written Opinion, App. No. PCT/US2014/060177, dated Dec. 19, 2014.  
 Rysavy, "Making the Call with Two-Way Paging", *Network Computing*, Published Jan. 15, 1997, [www.rysavy.com/Articles/twoway.htm](http://www.rysavy.com/Articles/twoway.htm).  
 Wachter, S. Blake; *Journal of the American Medical Informatics Association*; The Employment of an Iterative Design Process to Develop a Pulmonary Graphical Display; vol. 10, No. 4, Jul./Aug. 2003; pp. 363-372.  
 U.S. Appl. No. 12/973,392, filed Dec. 20, 2010, Kiani et al.  
 U.S. Appl. No. 29/537,221, filed Aug. 24, 2015, Al-Ali et al.  
 International Preliminary Report on Patentability & Written Opinion in PCT Application No. PCT/US2014/060177, dated Apr. 21, 2016.  
 Official Communication in European Application No. 10195398.2 dated Jul. 6, 2016.

\* cited by examiner

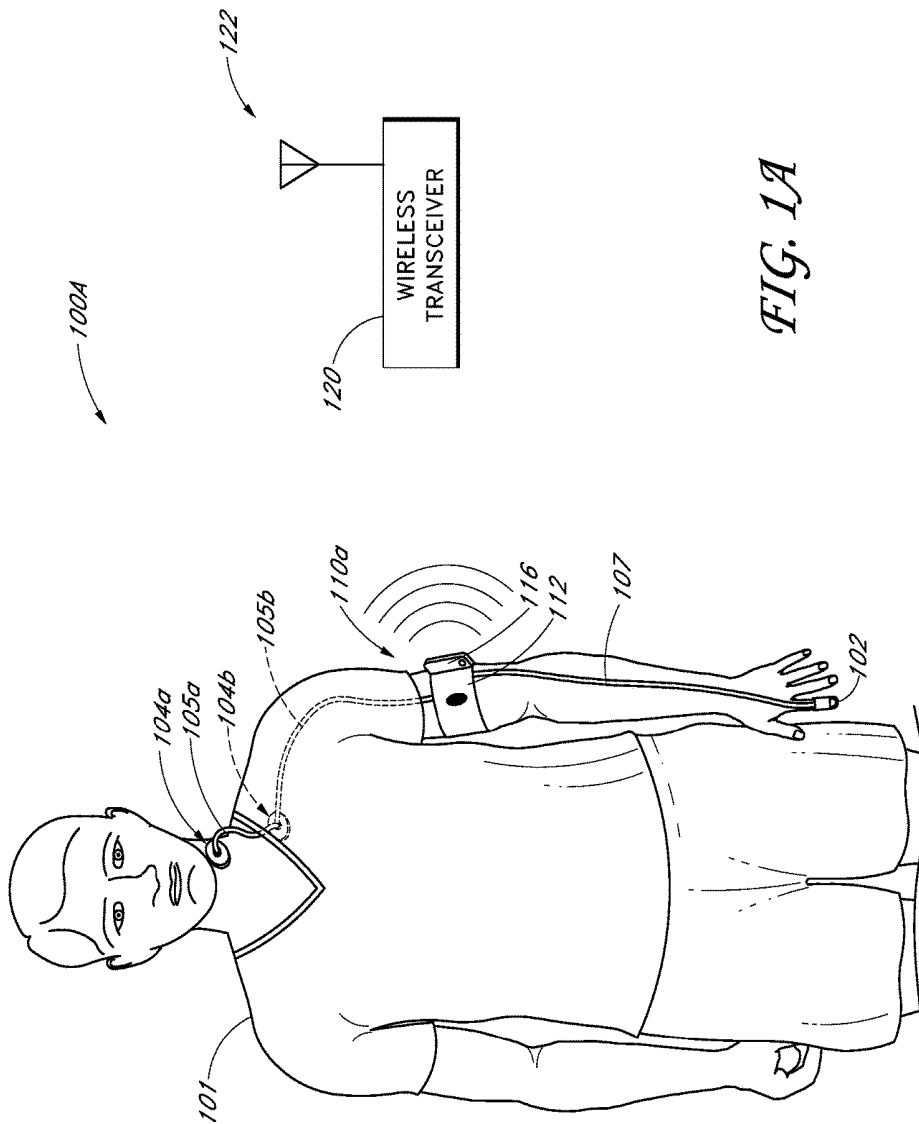

FIG. 1A

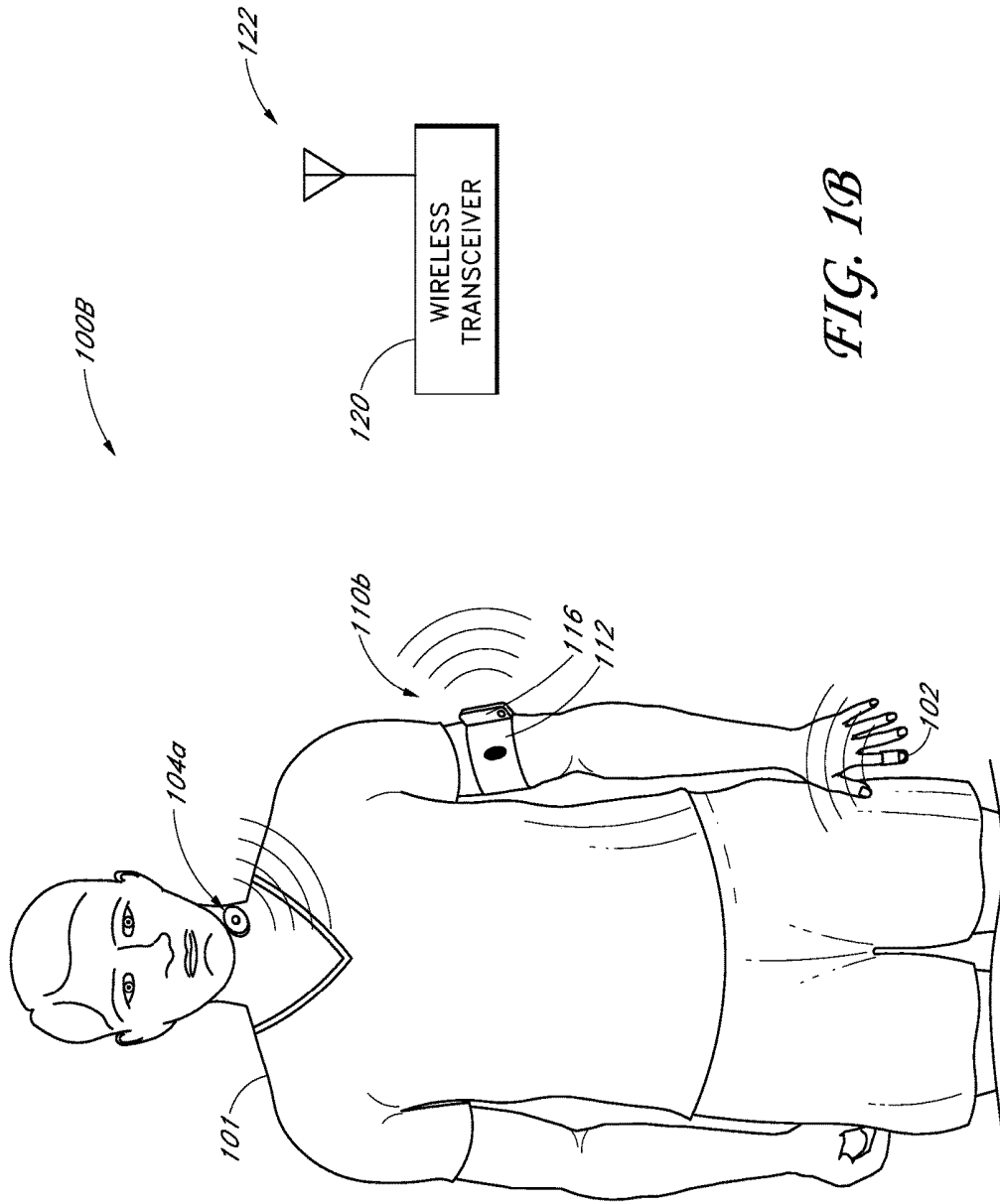
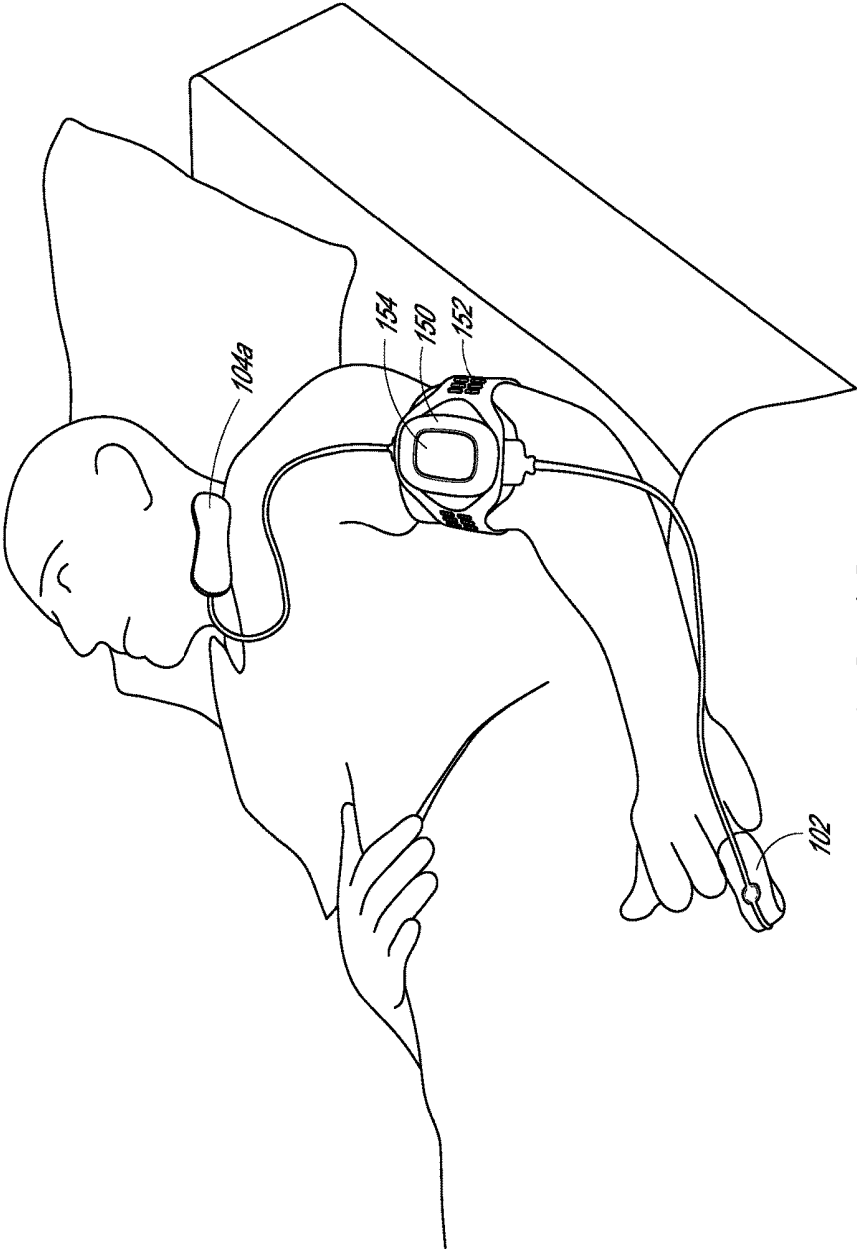

FIG. 1B



*FIG. 1C*

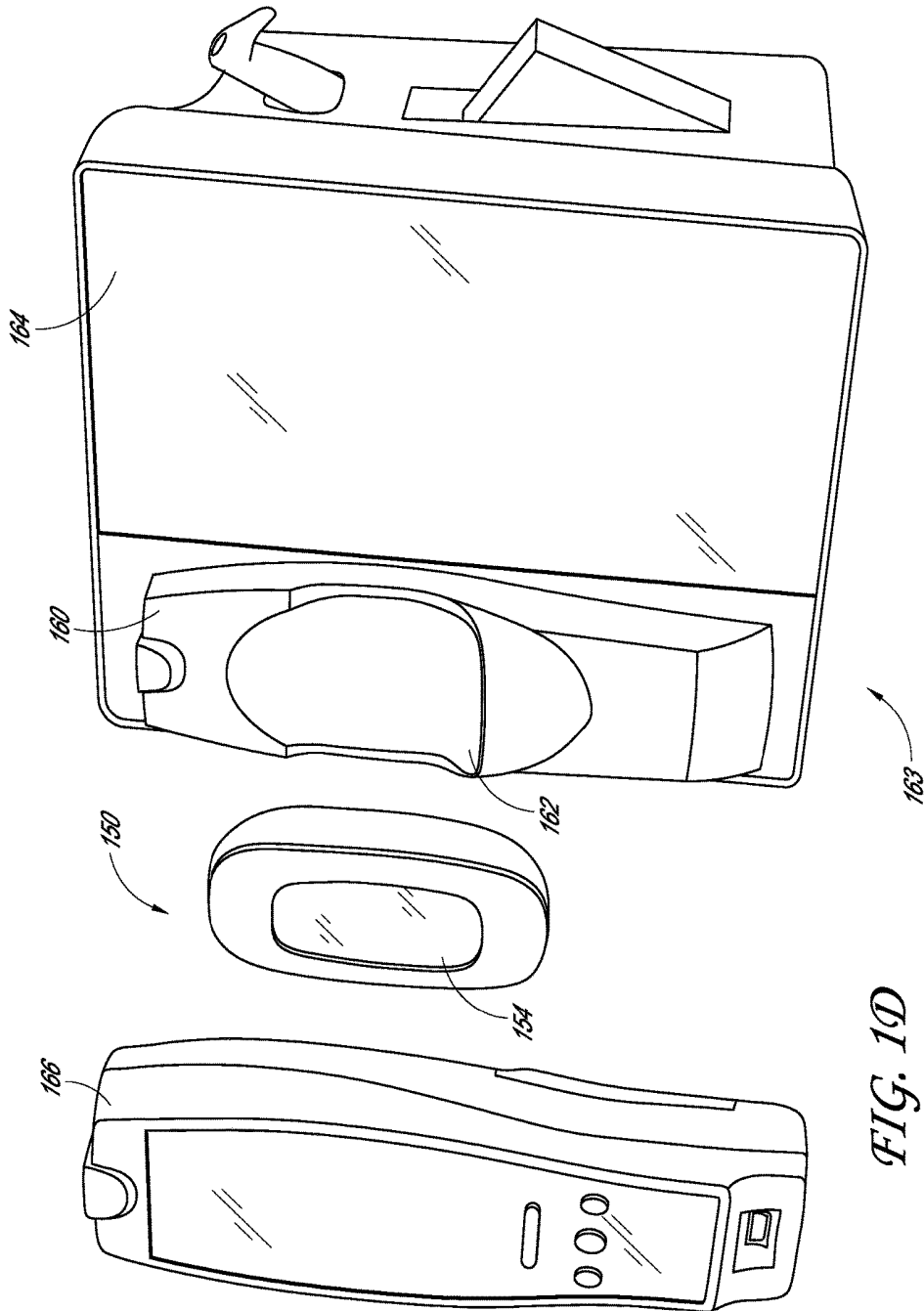

FIG. 1D

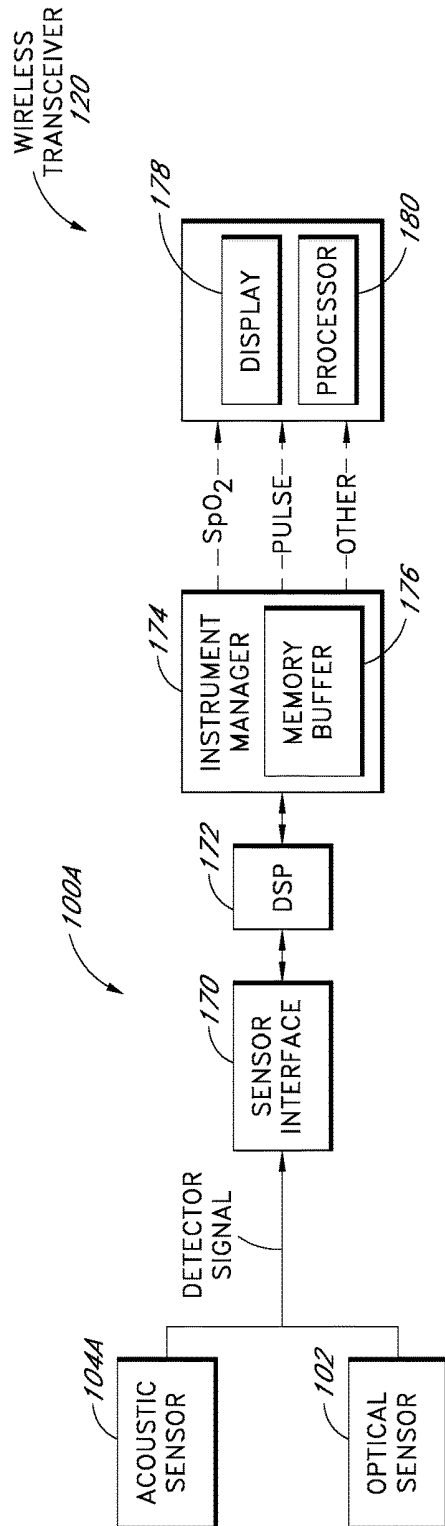

FIG. 1E

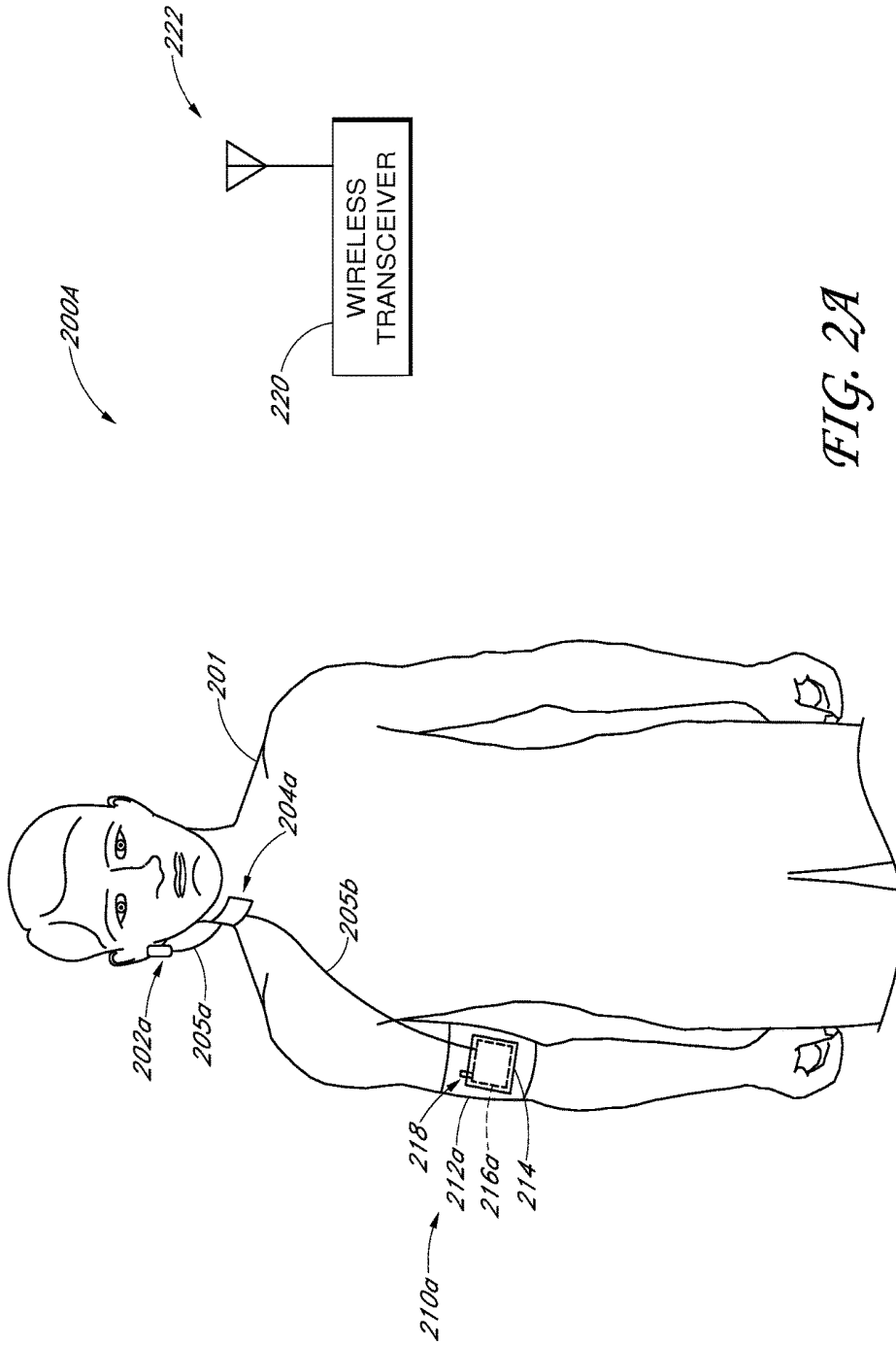

FIG. 2A

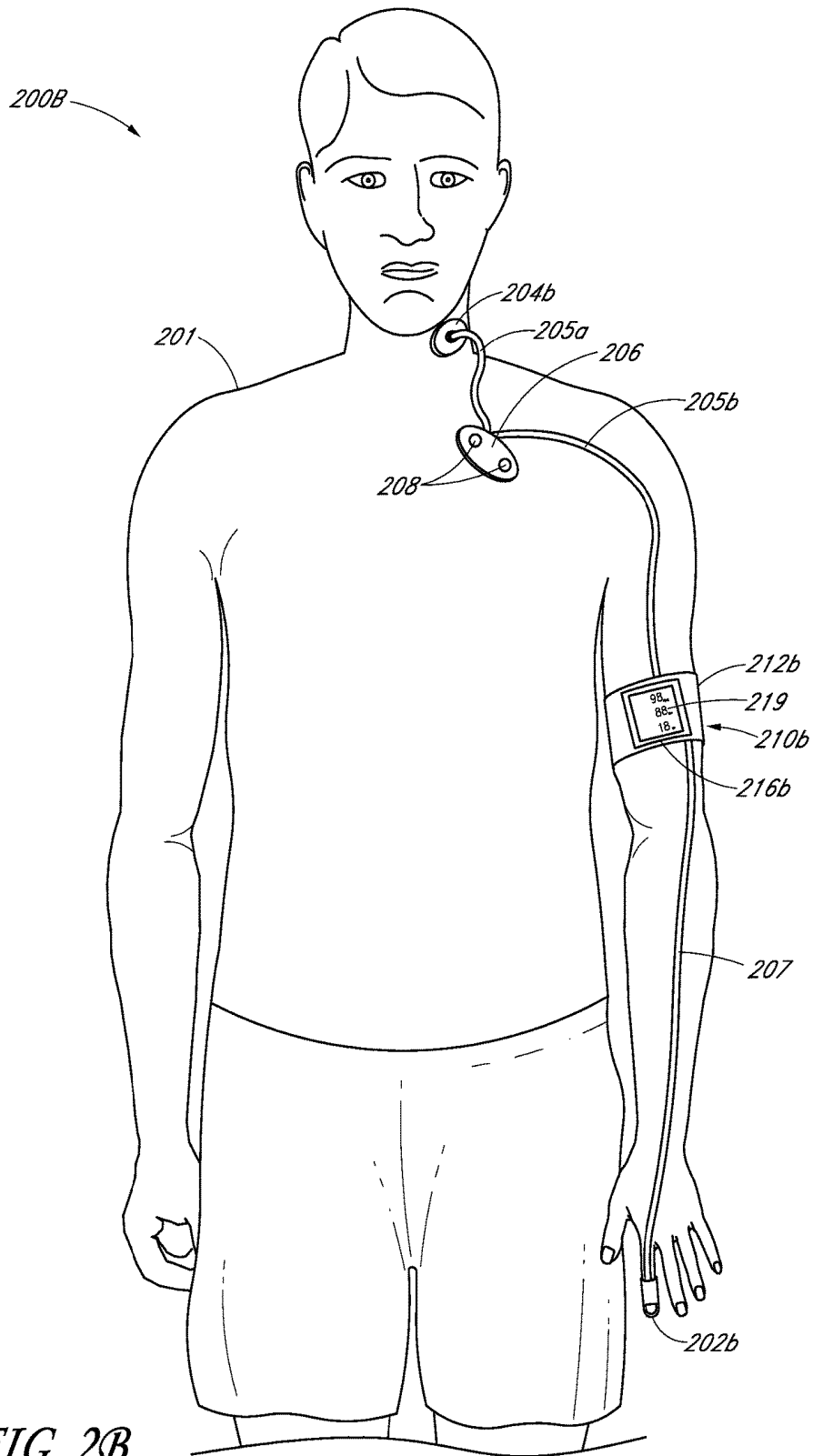

FIG. 2B

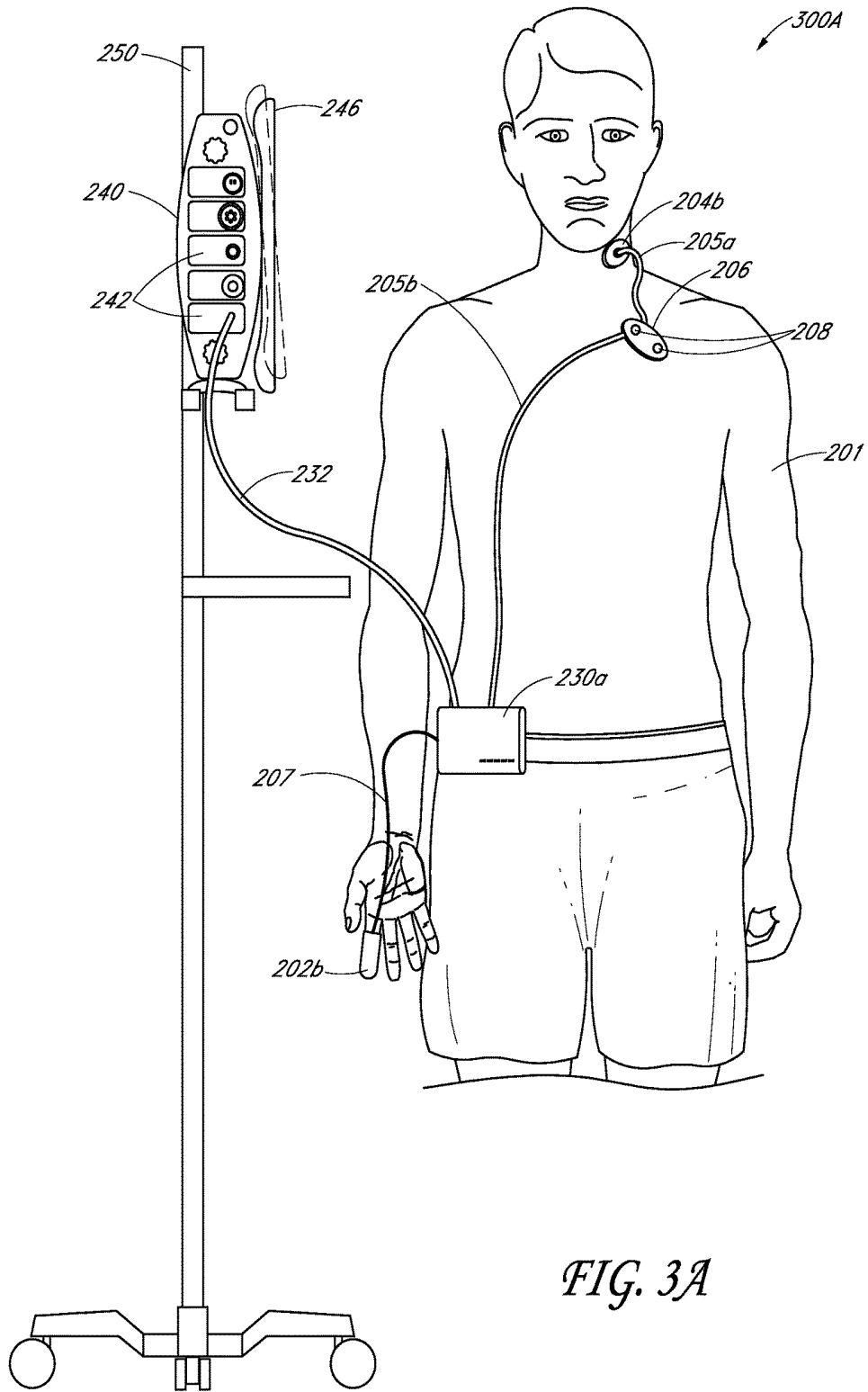

FIG. 3A

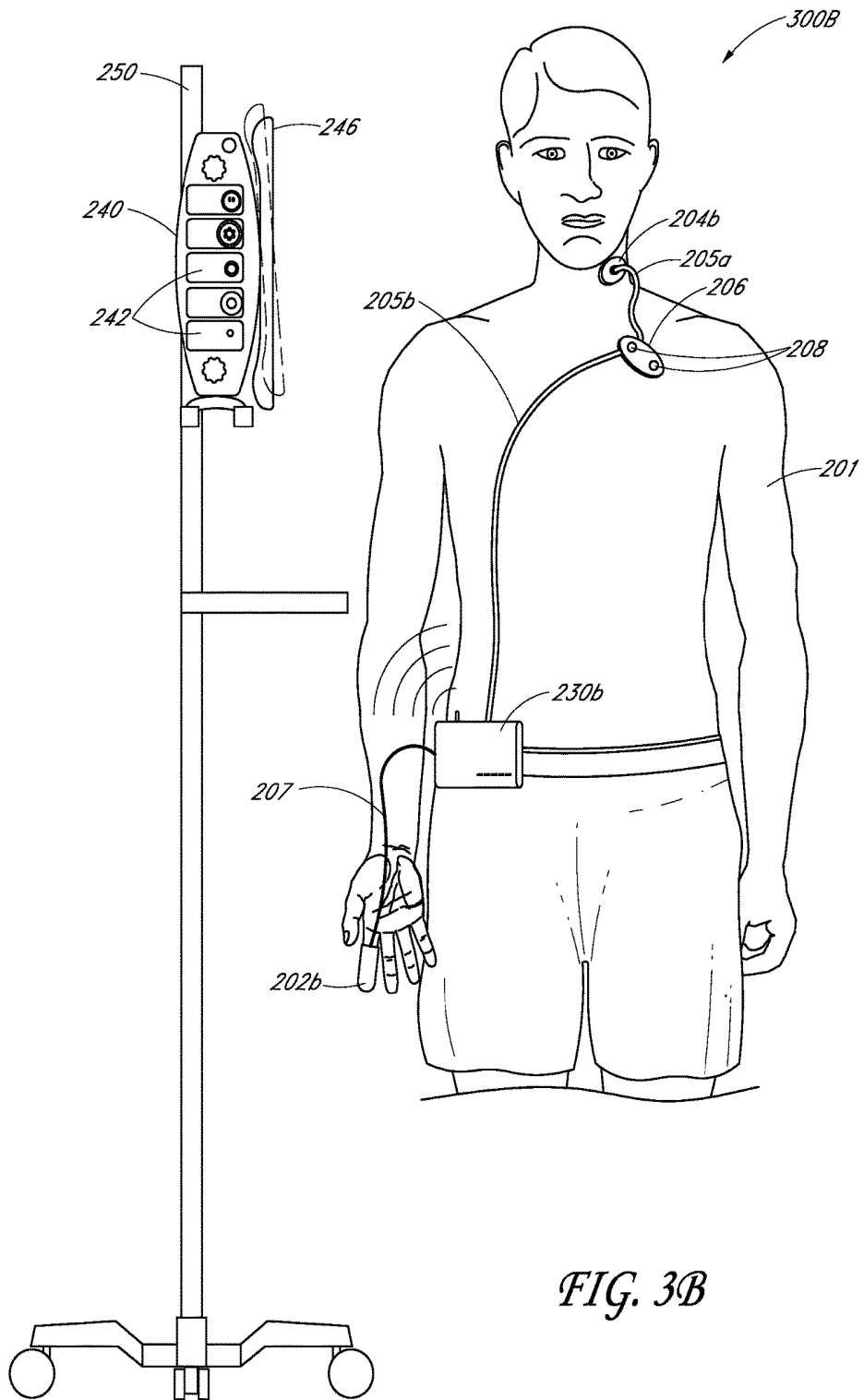

FIG. 3B

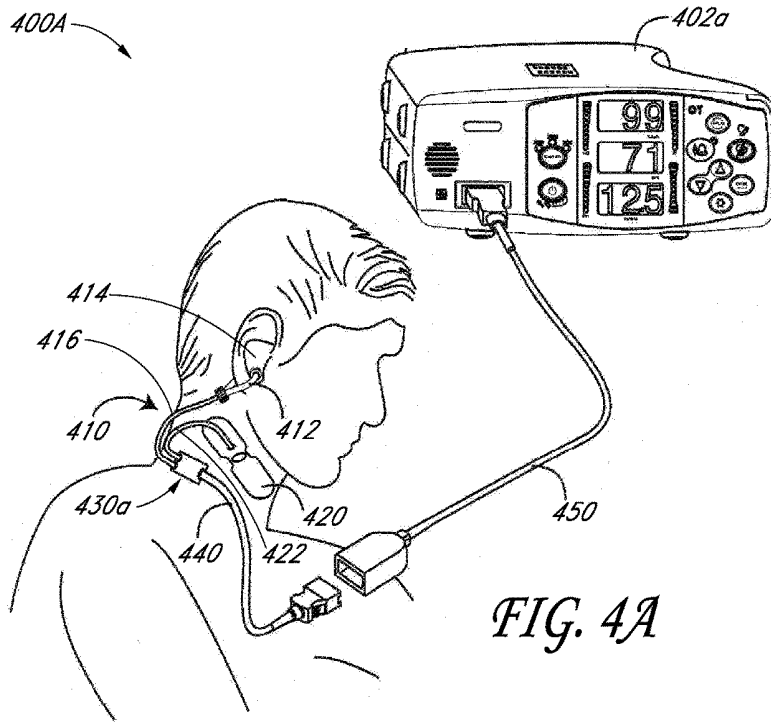

FIG. 4A

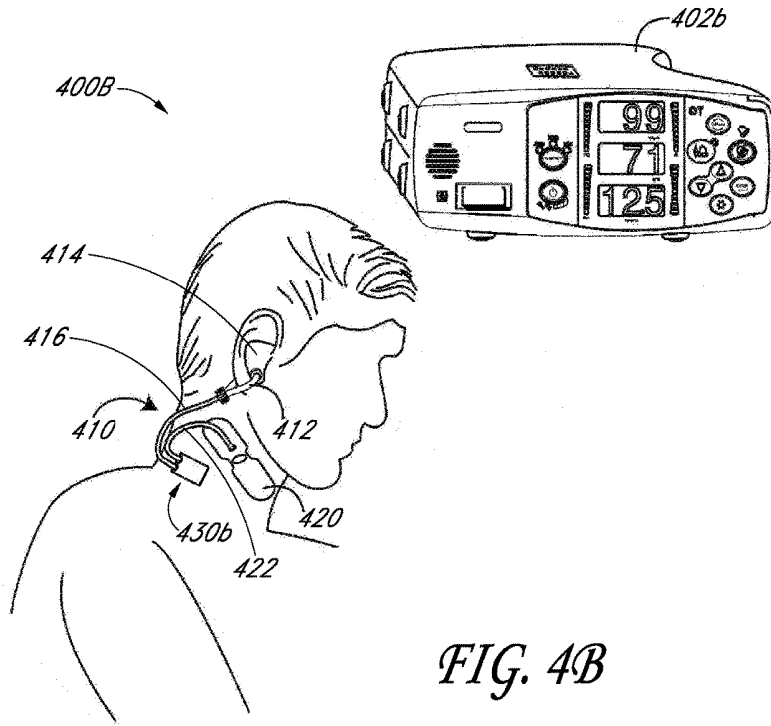

FIG. 4B

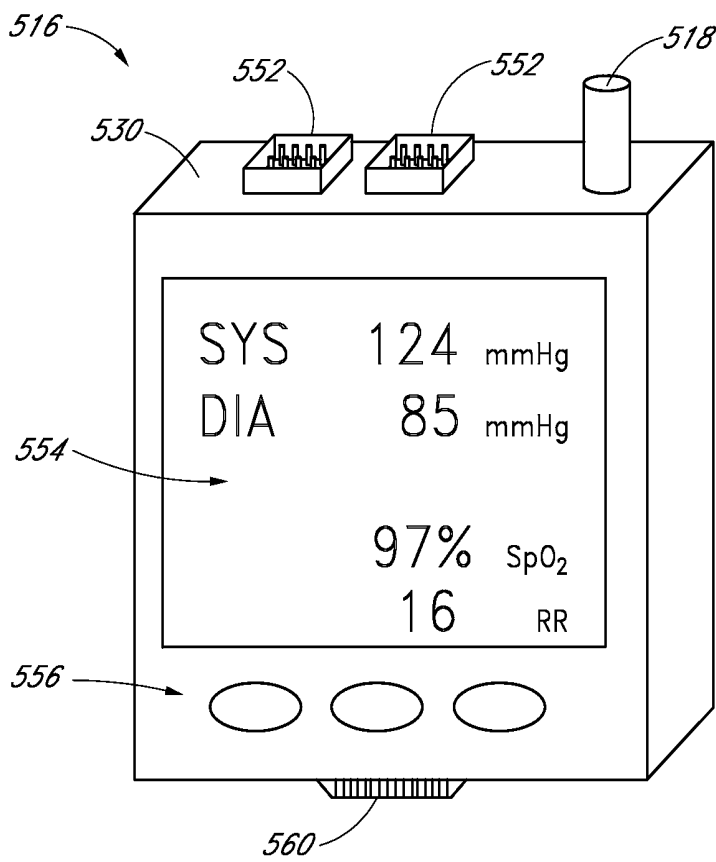

FIG. 5

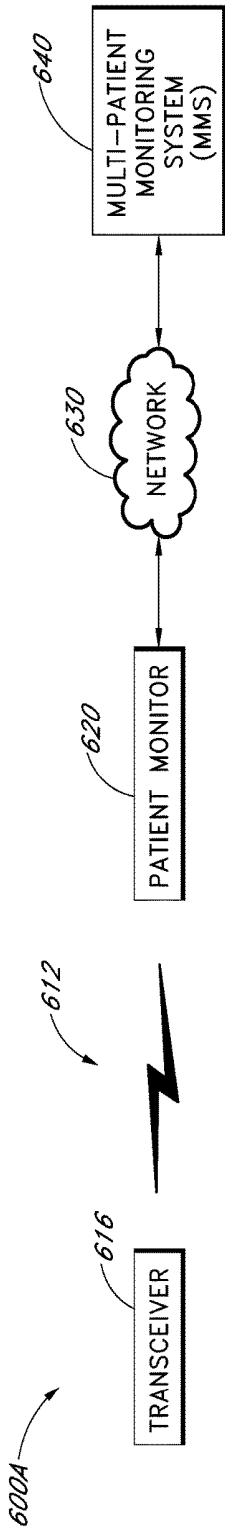

FIG. 6A

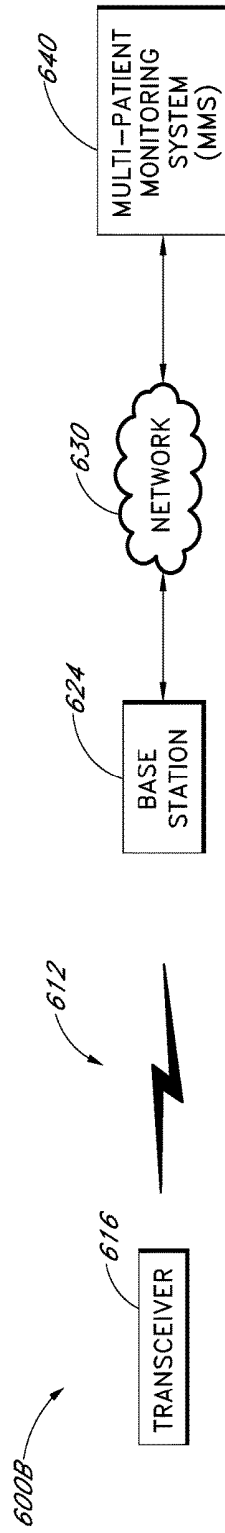

FIG. 6B

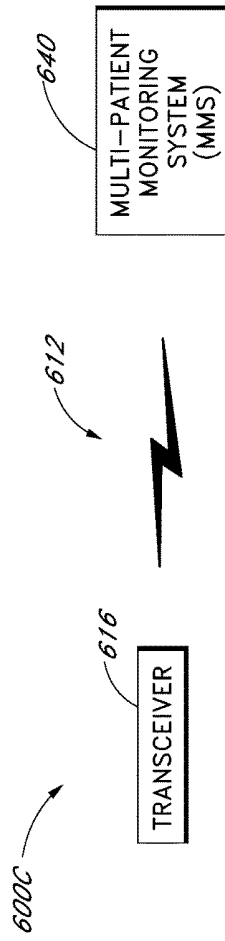

FIG. 6C

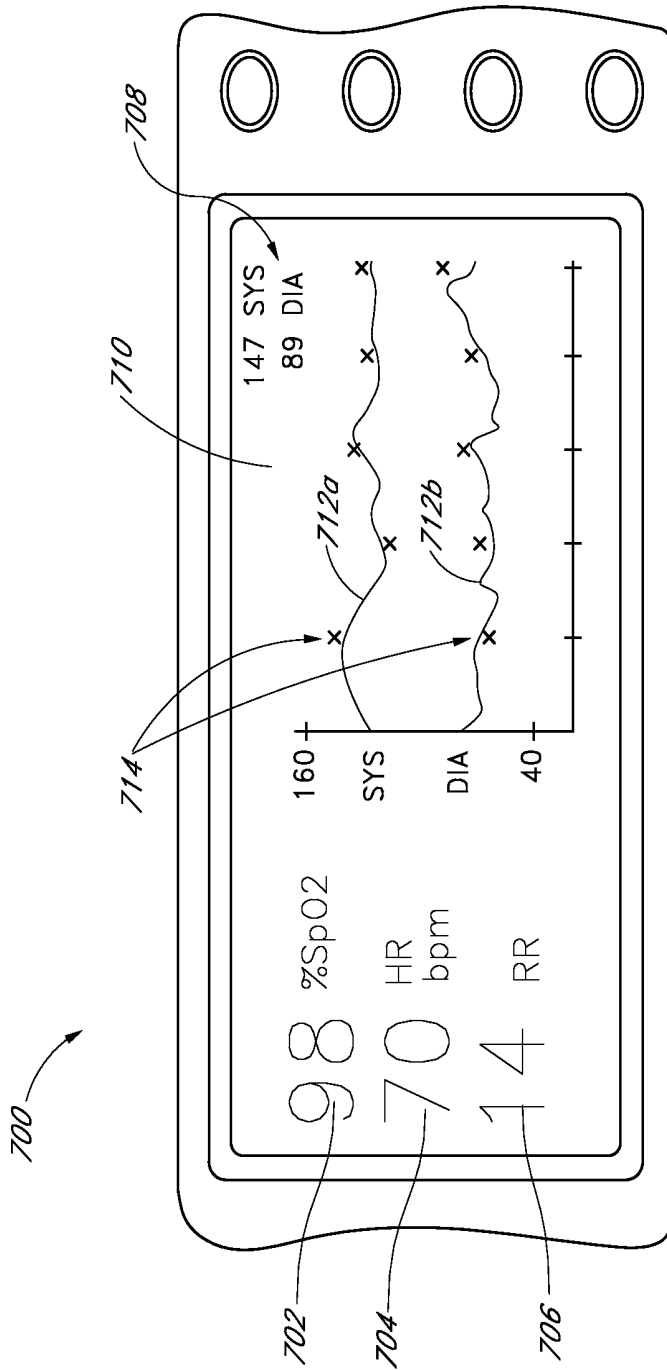

FIG. 7

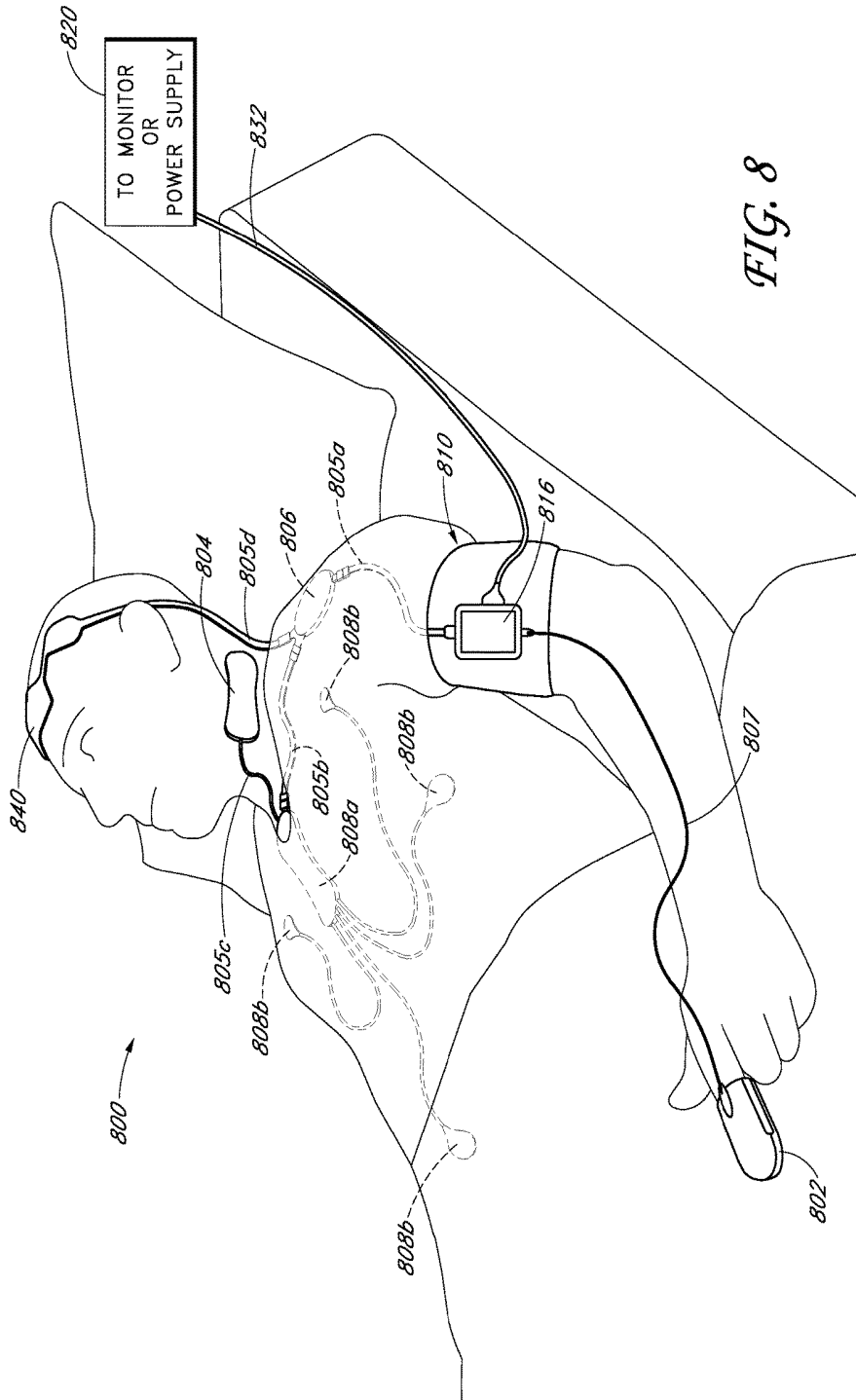

FIG. 8

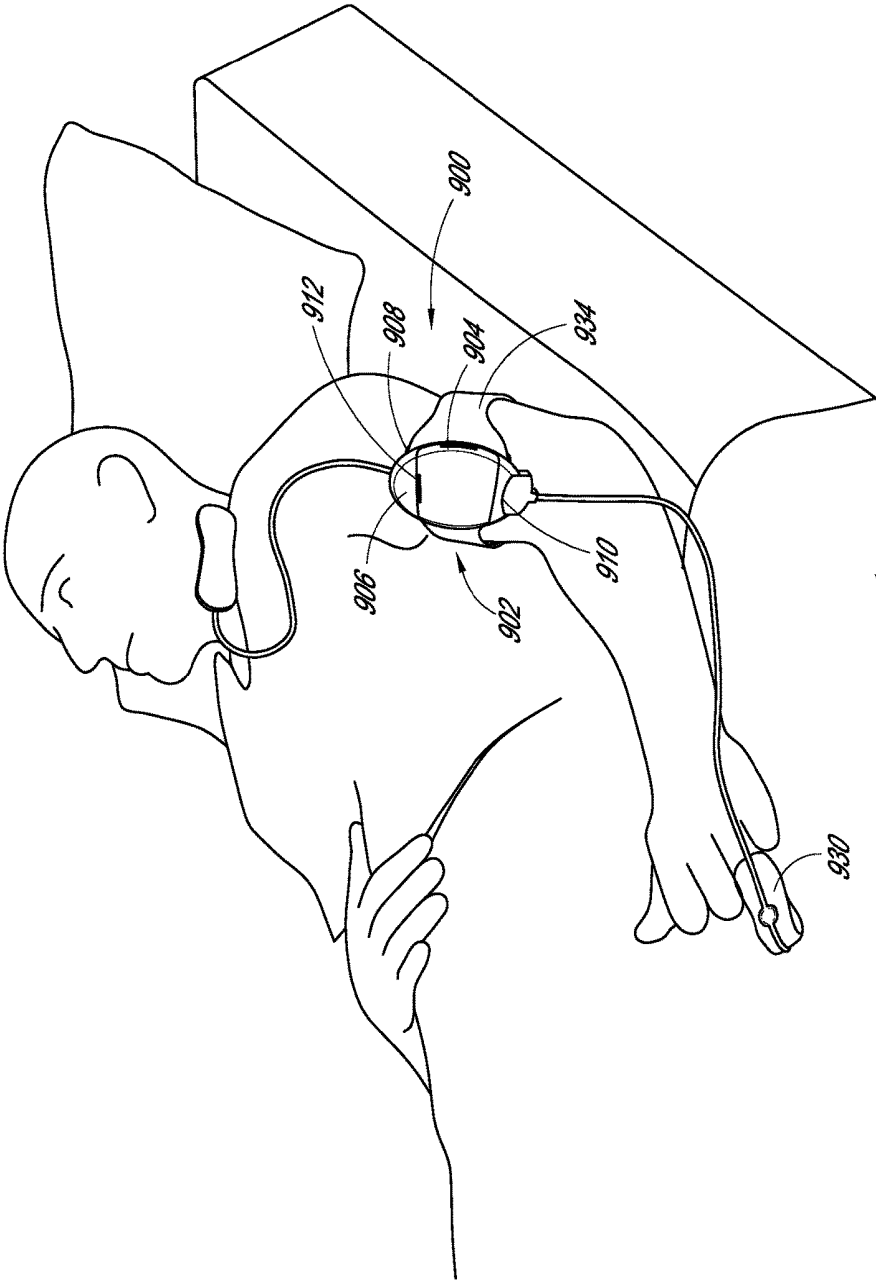

FIG. 9A

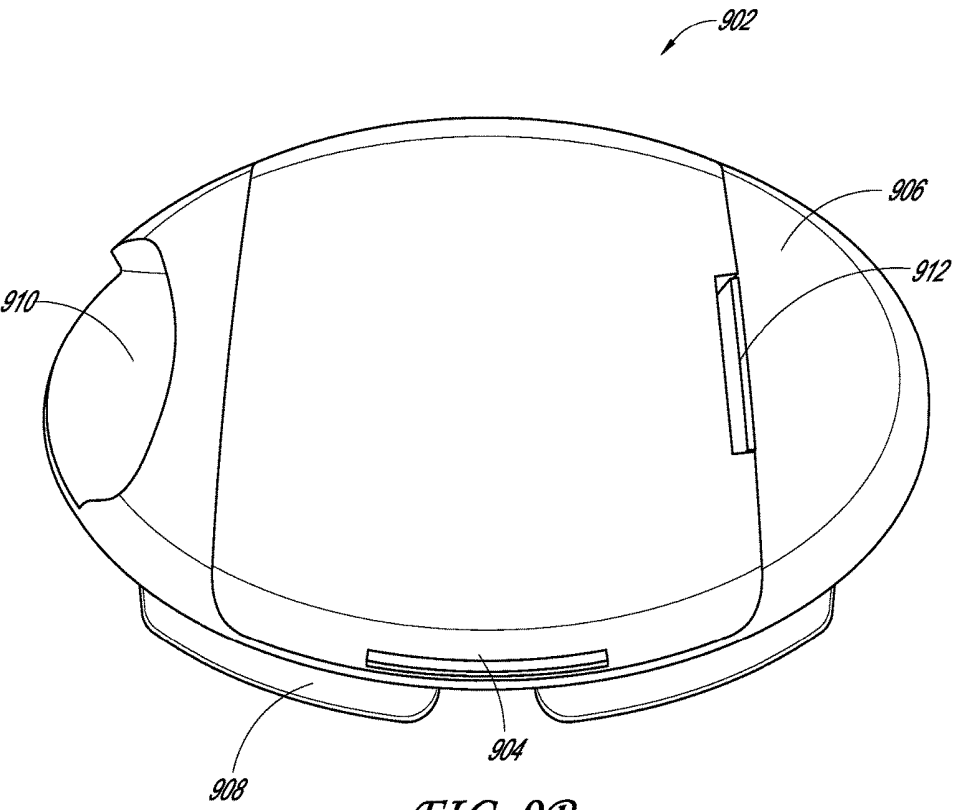

FIG. 9B

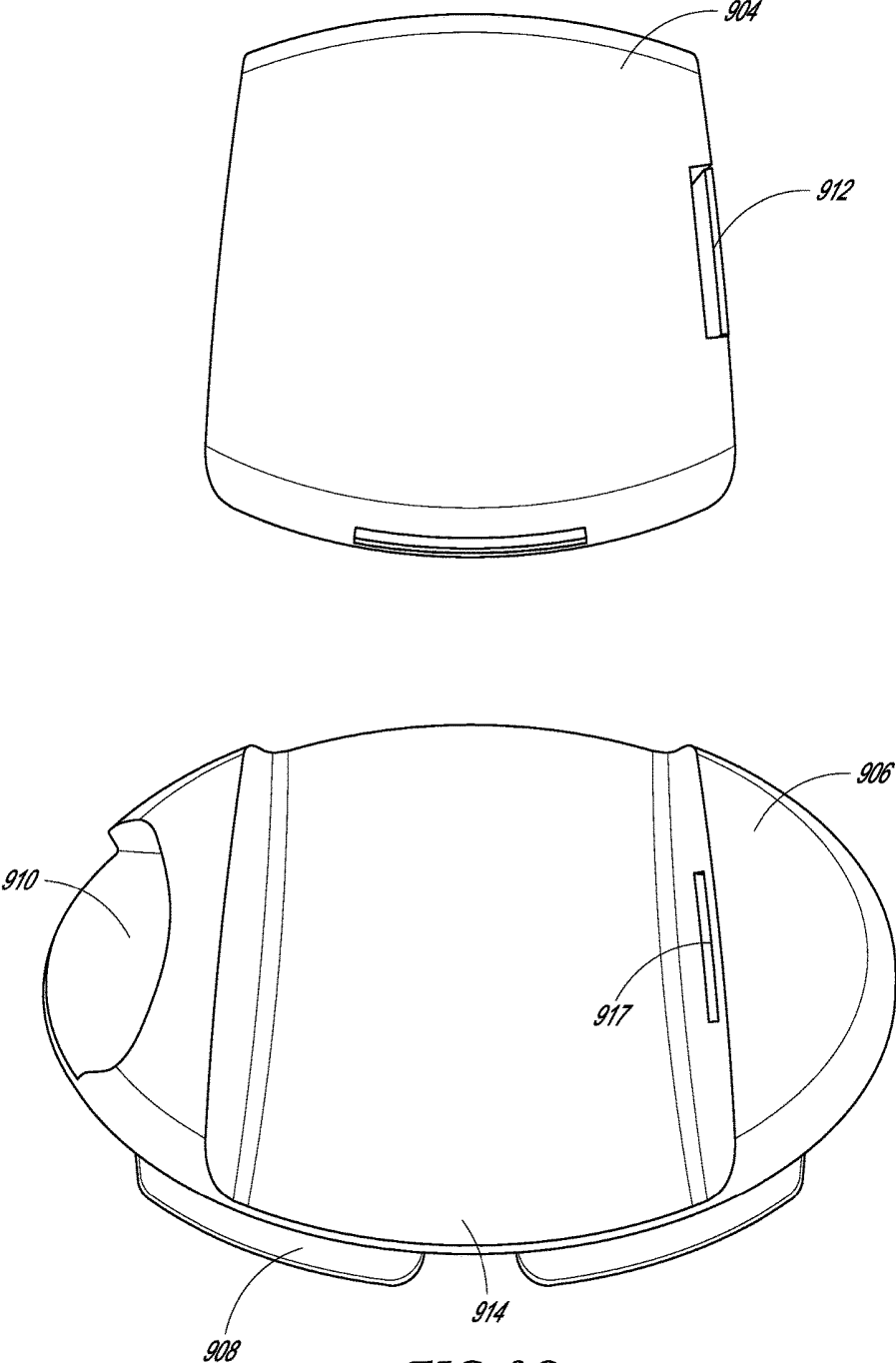

FIG. 9C

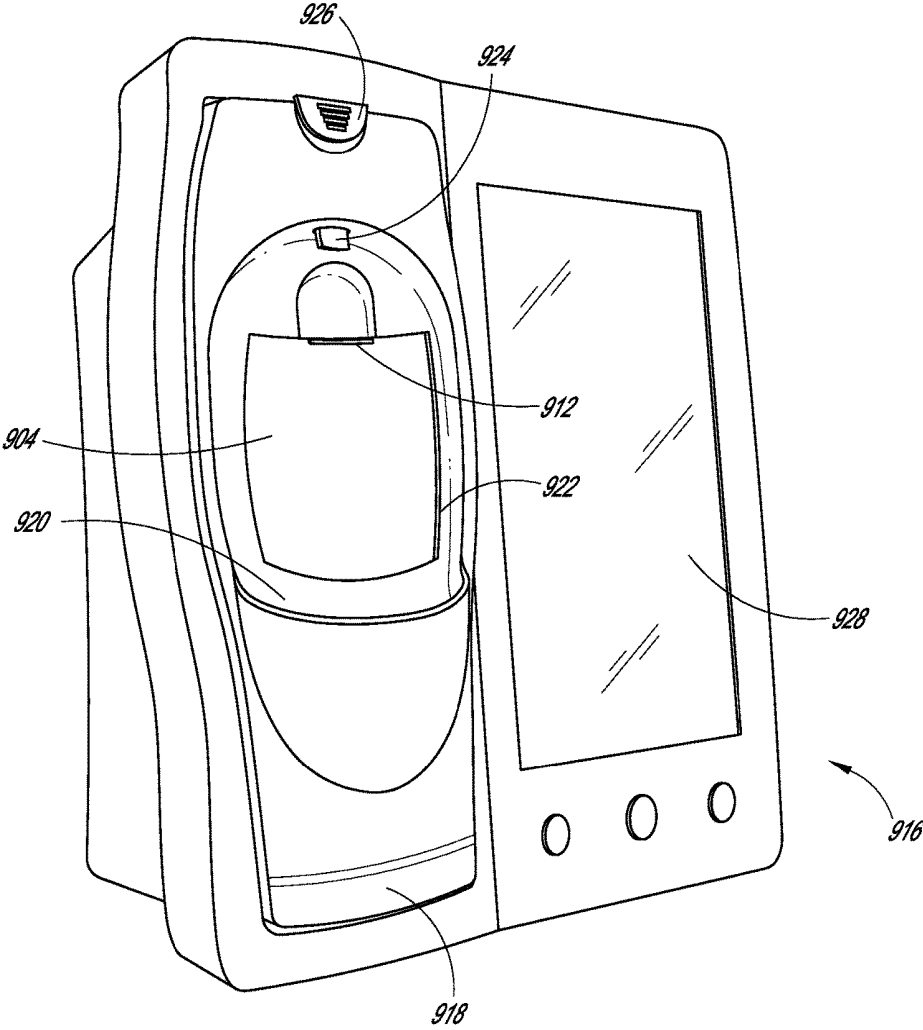

FIG. 9D

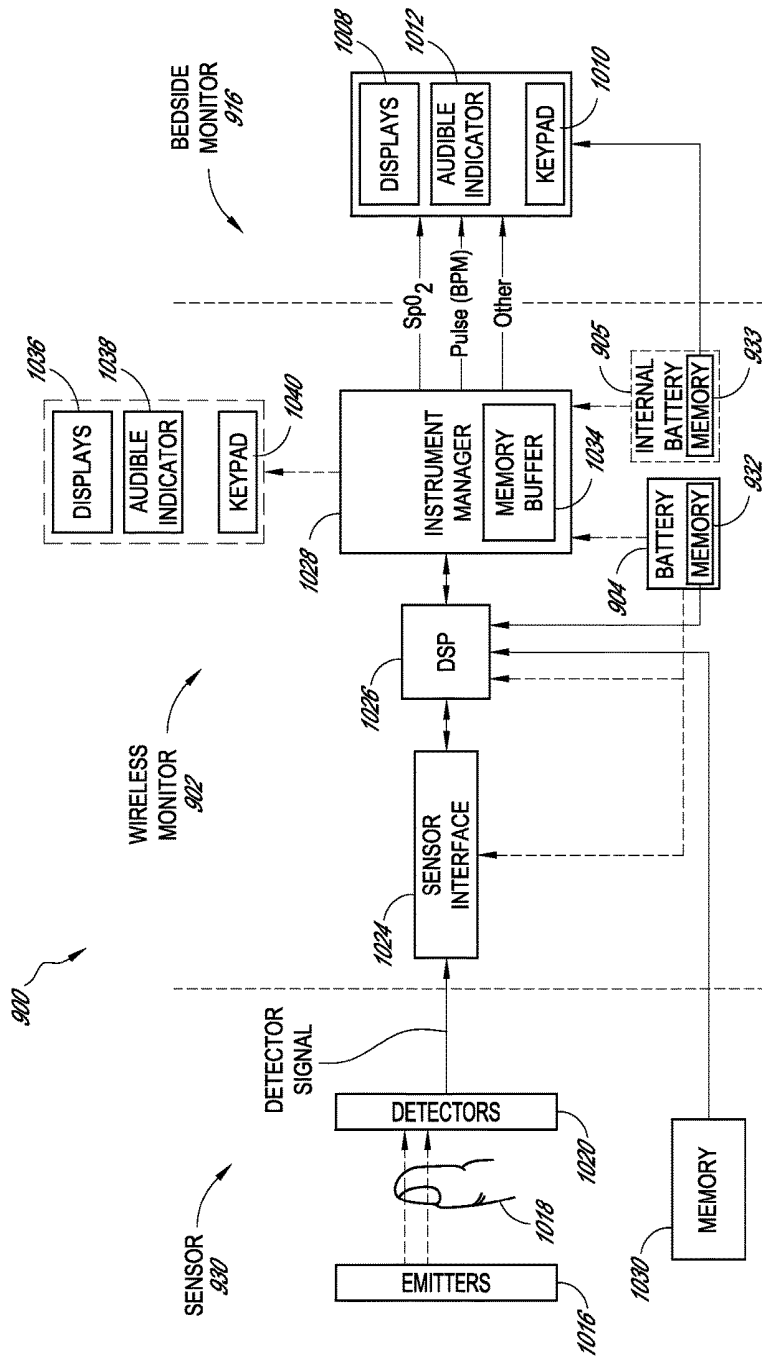

FIG. 10

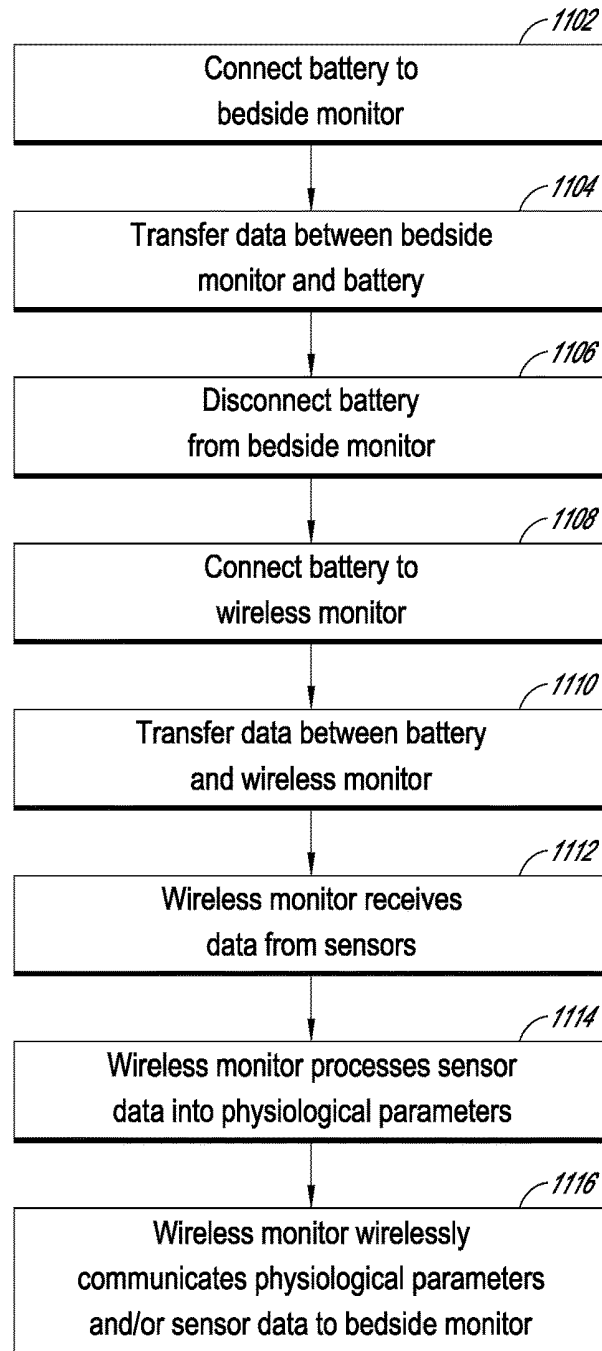

FIG. 11

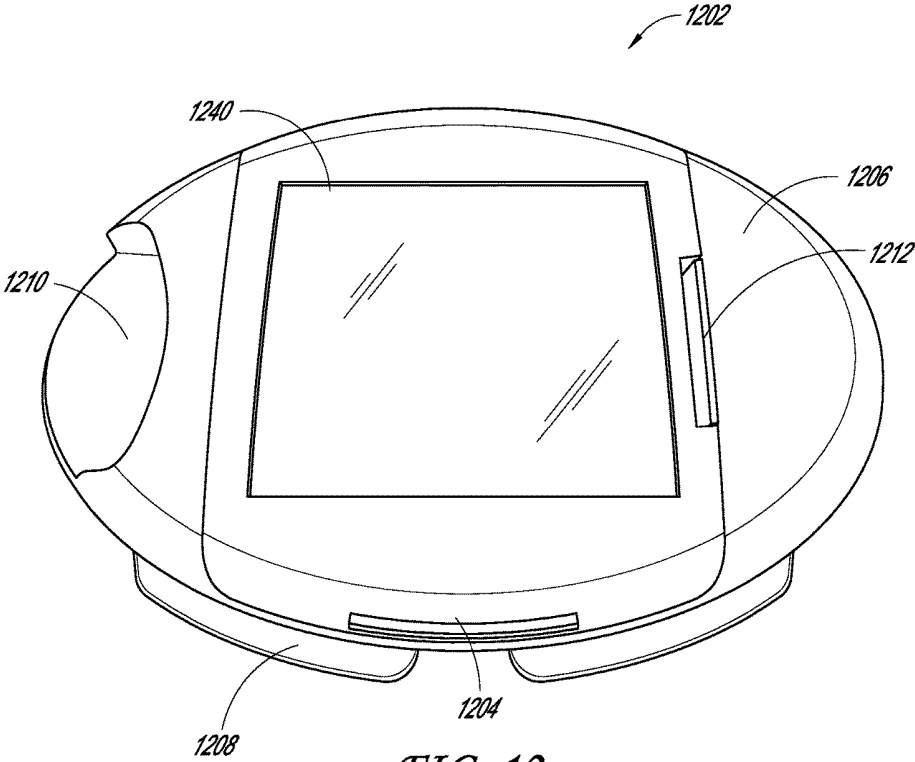

FIG. 12

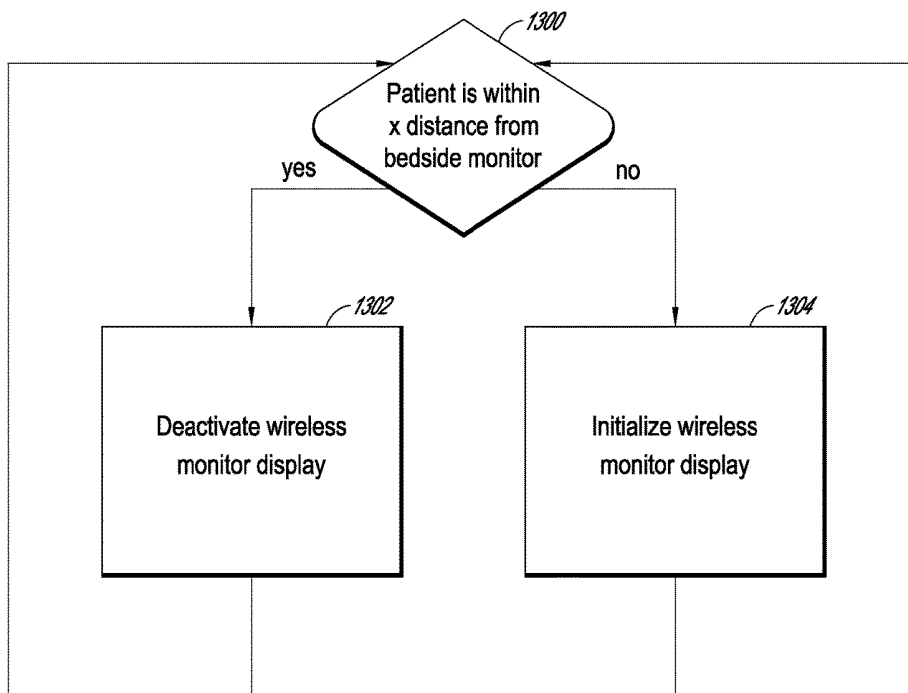

FIG. 13

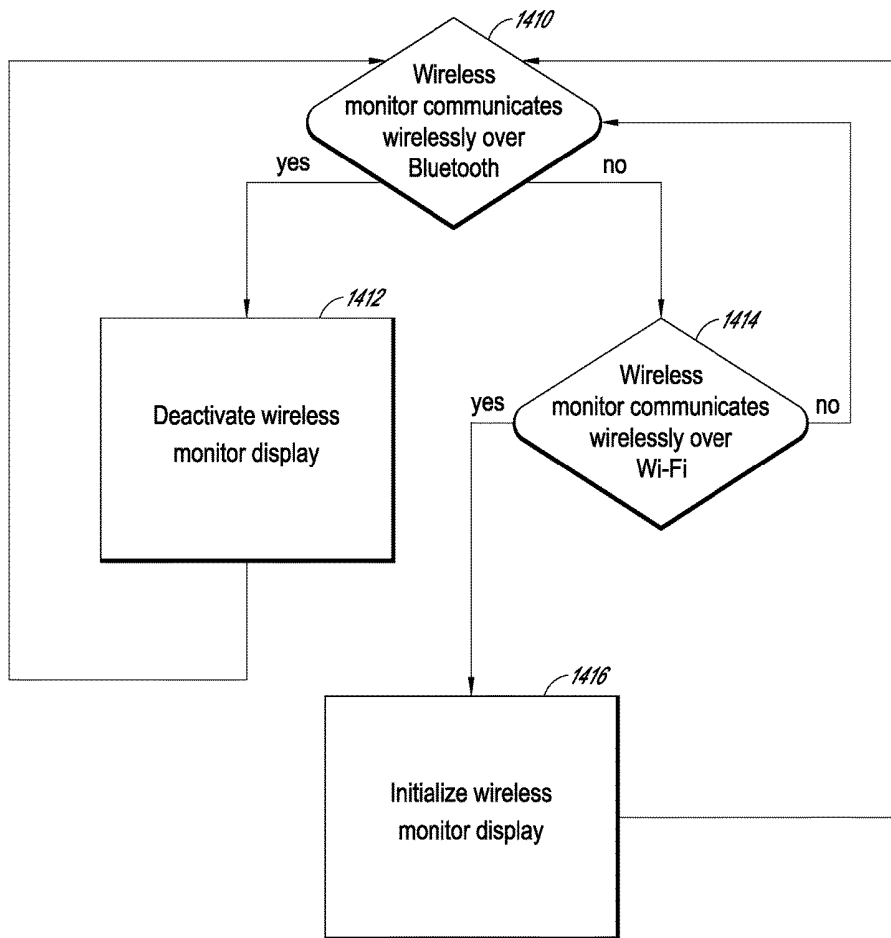

FIG. 14

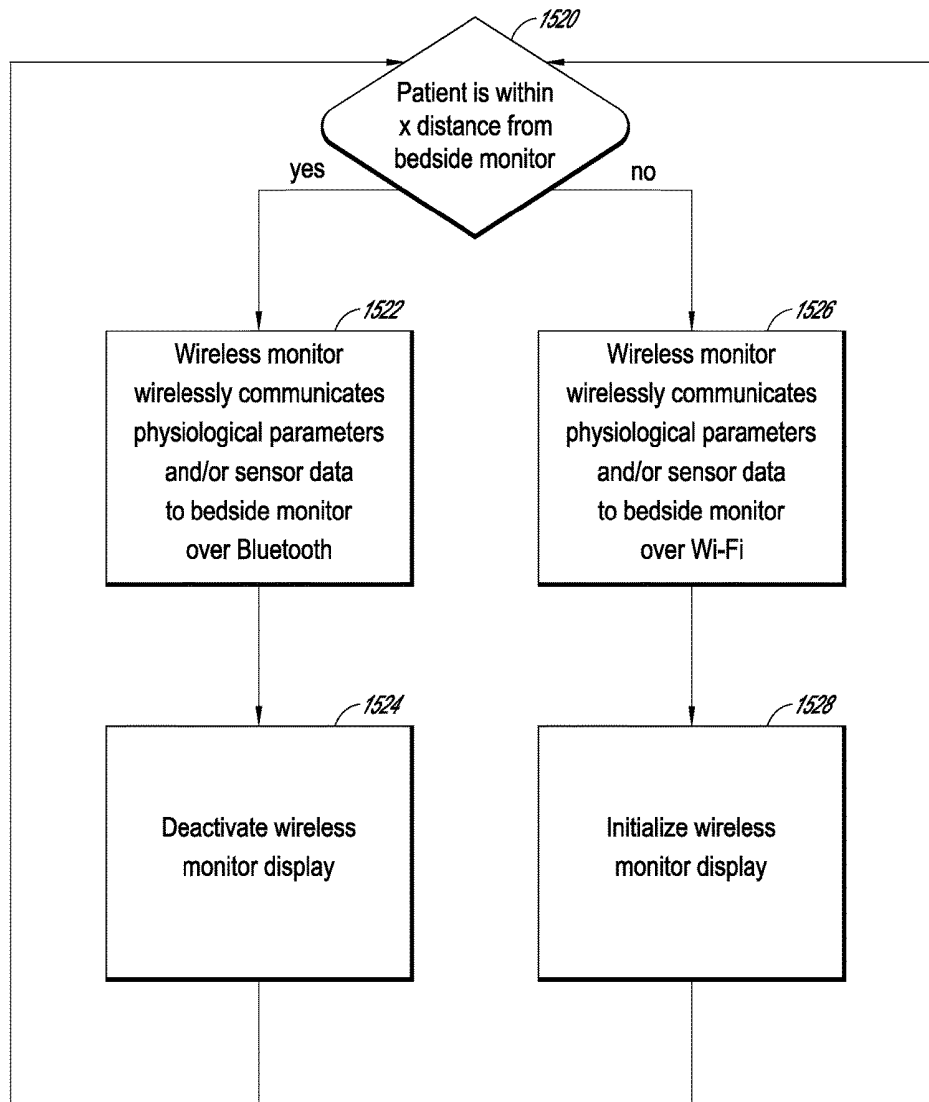

FIG. 15

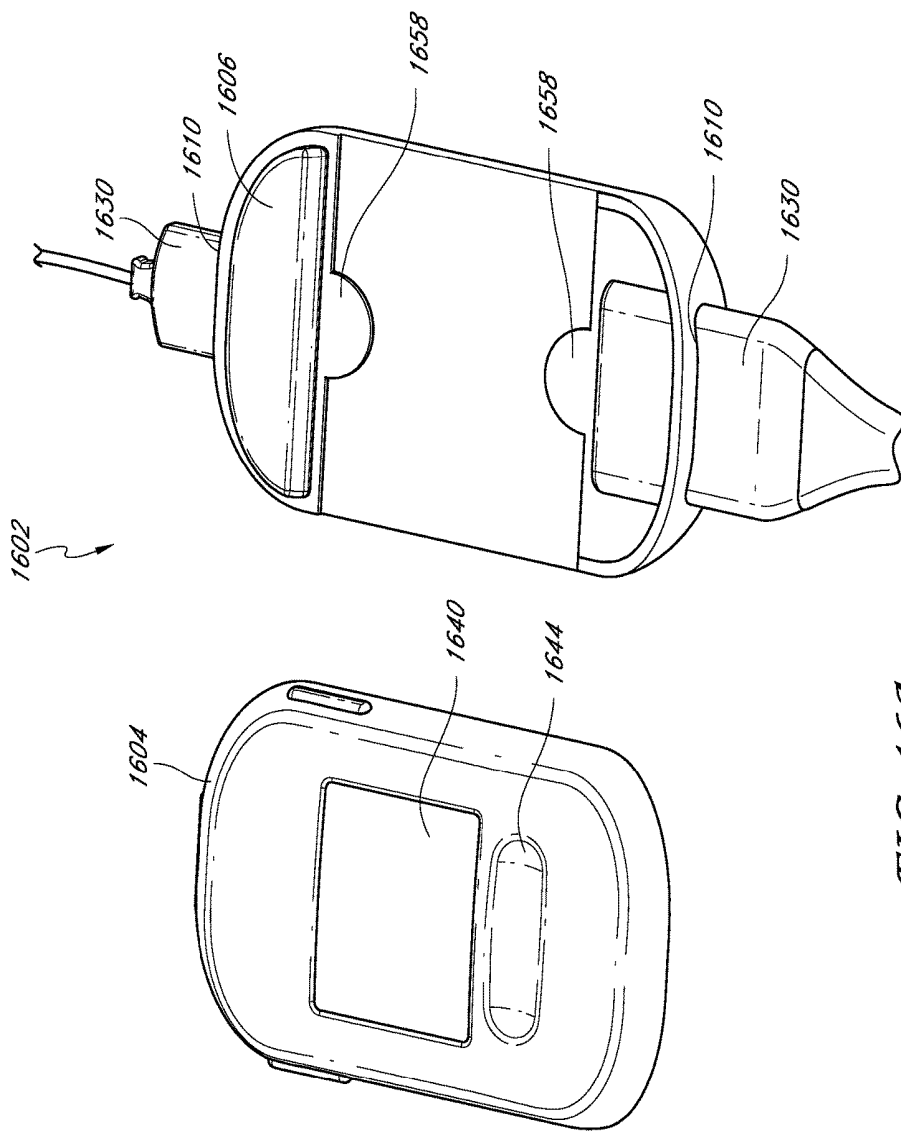

FIG. 16A

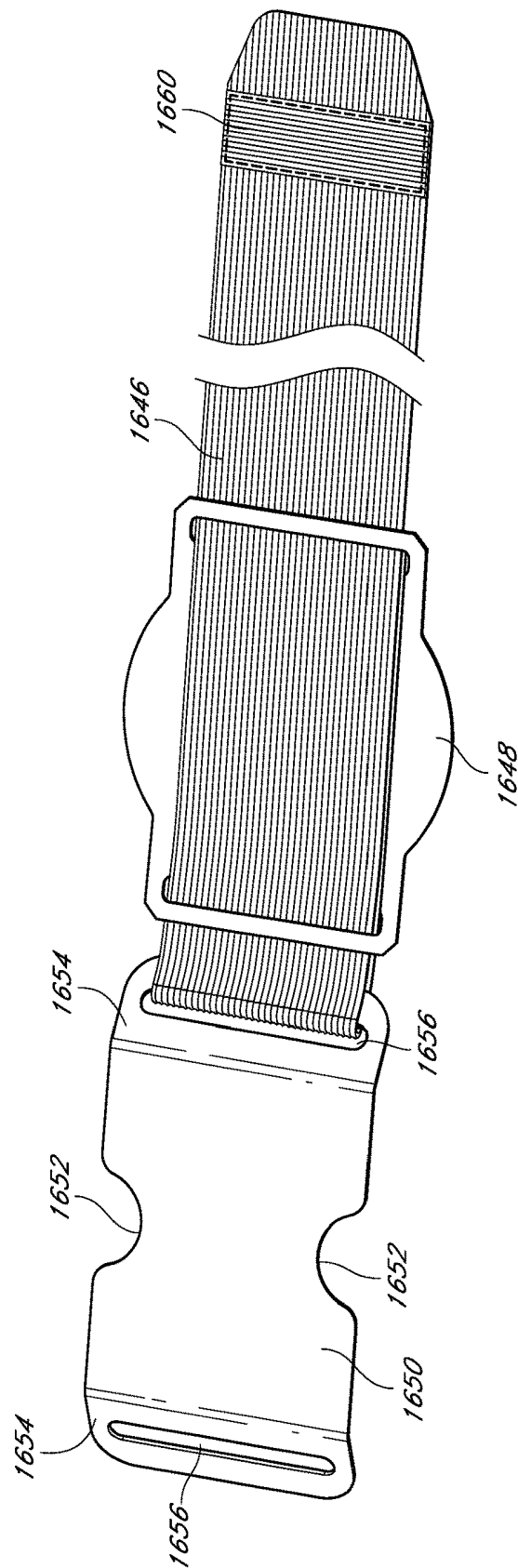

FIG. 16B

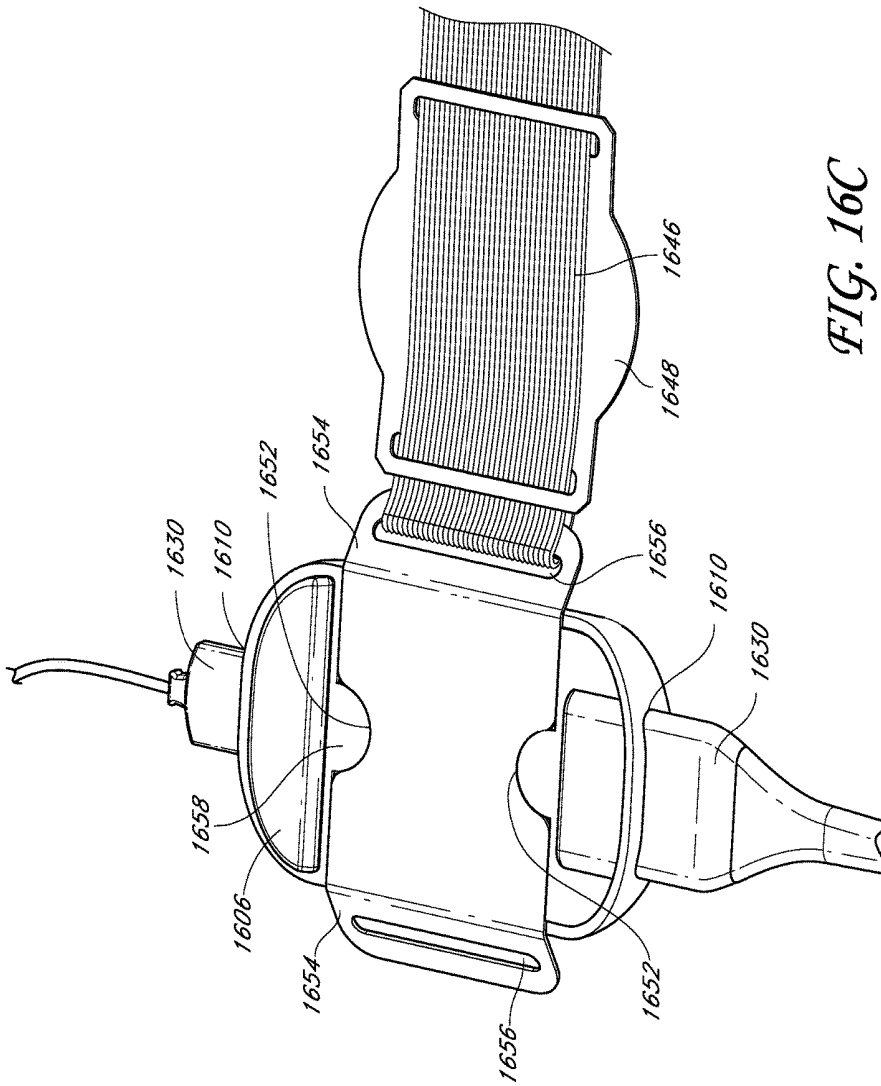

FIG. 16C

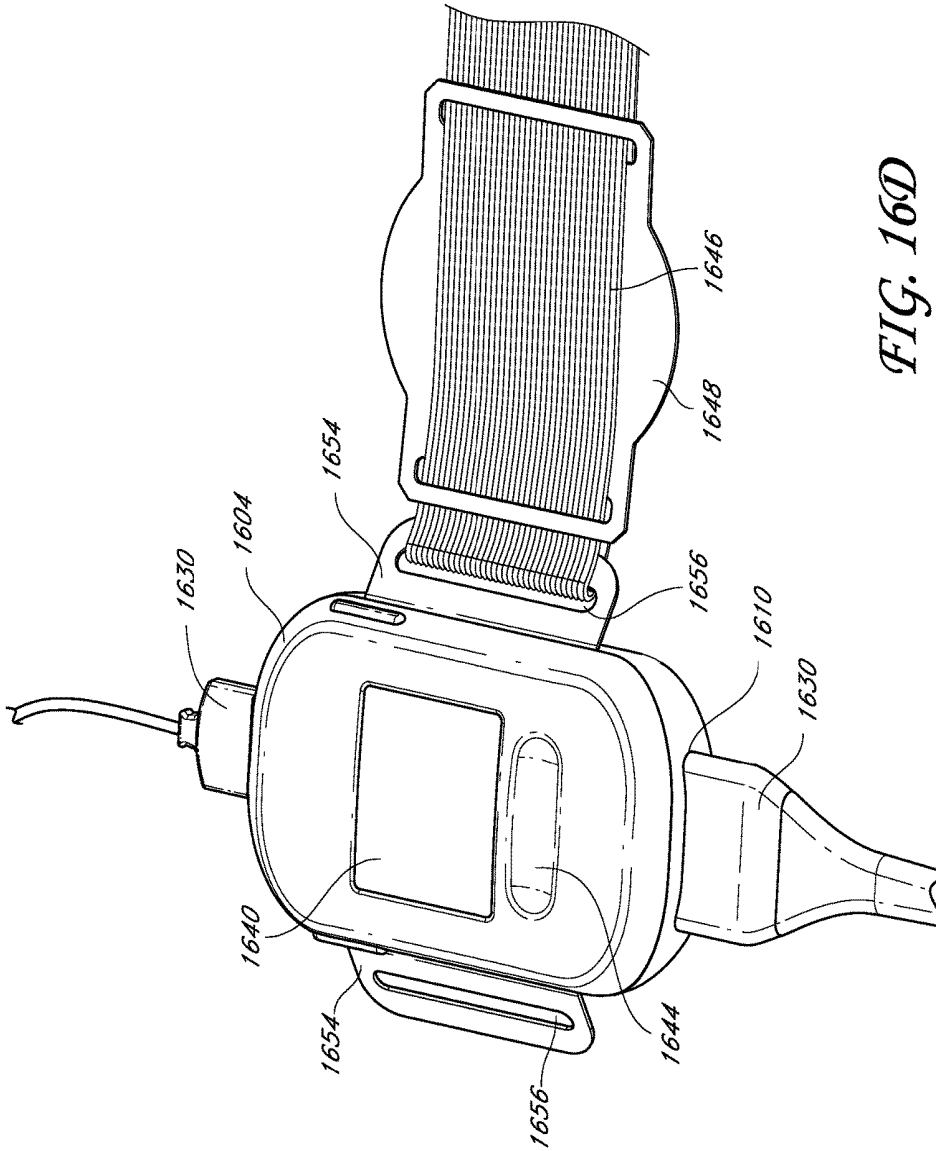

FIG. 16D

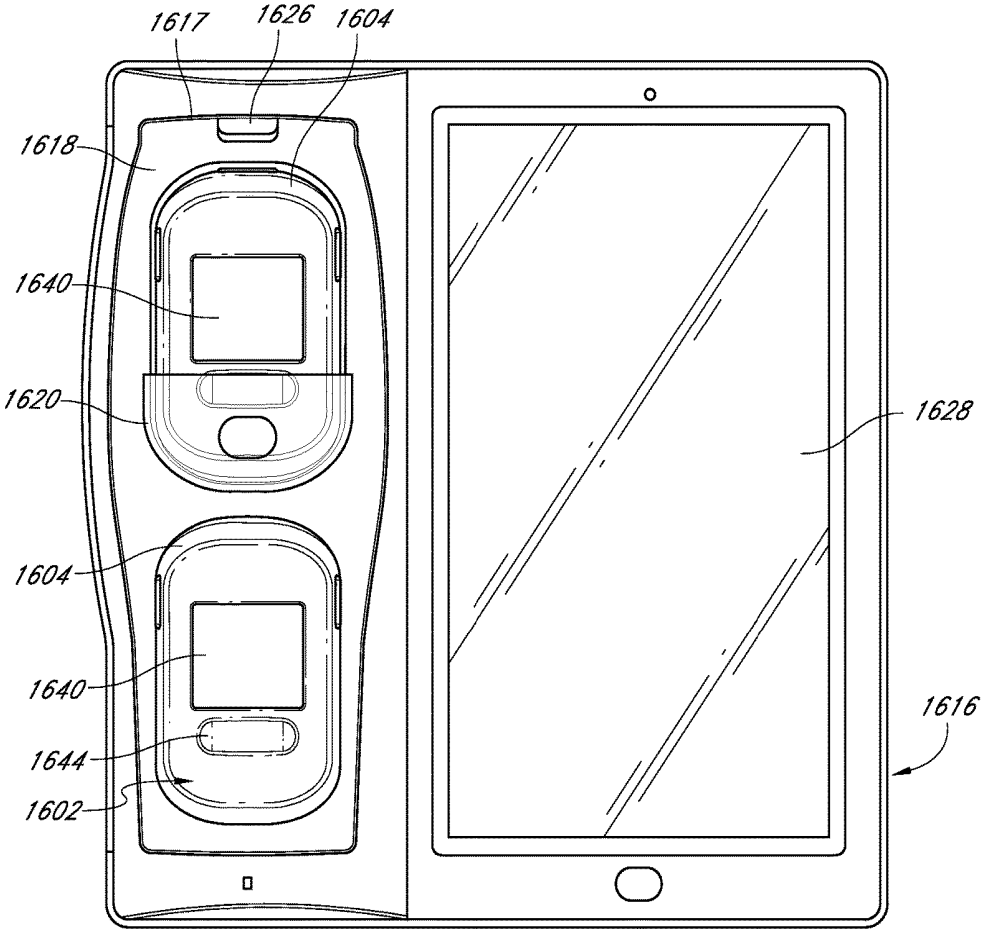

FIG. 16E

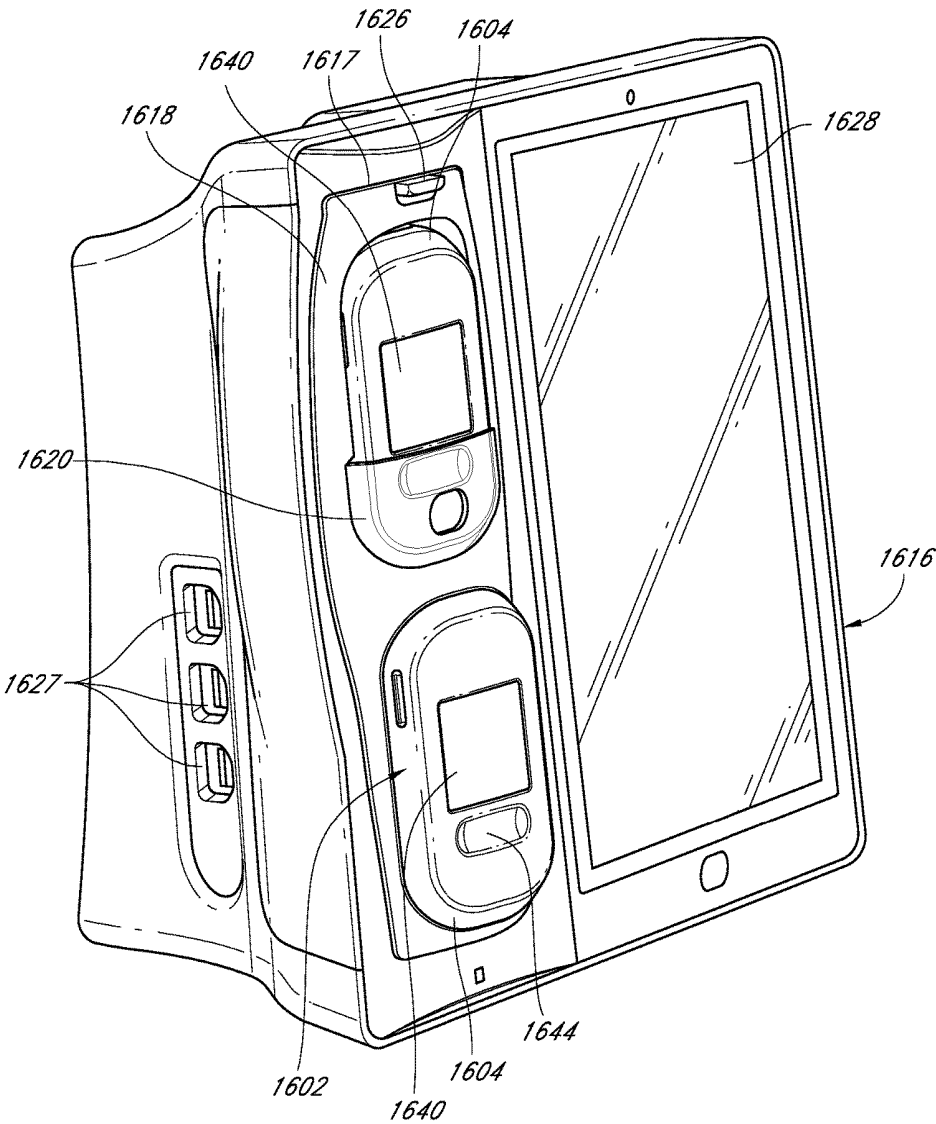

FIG. 16F

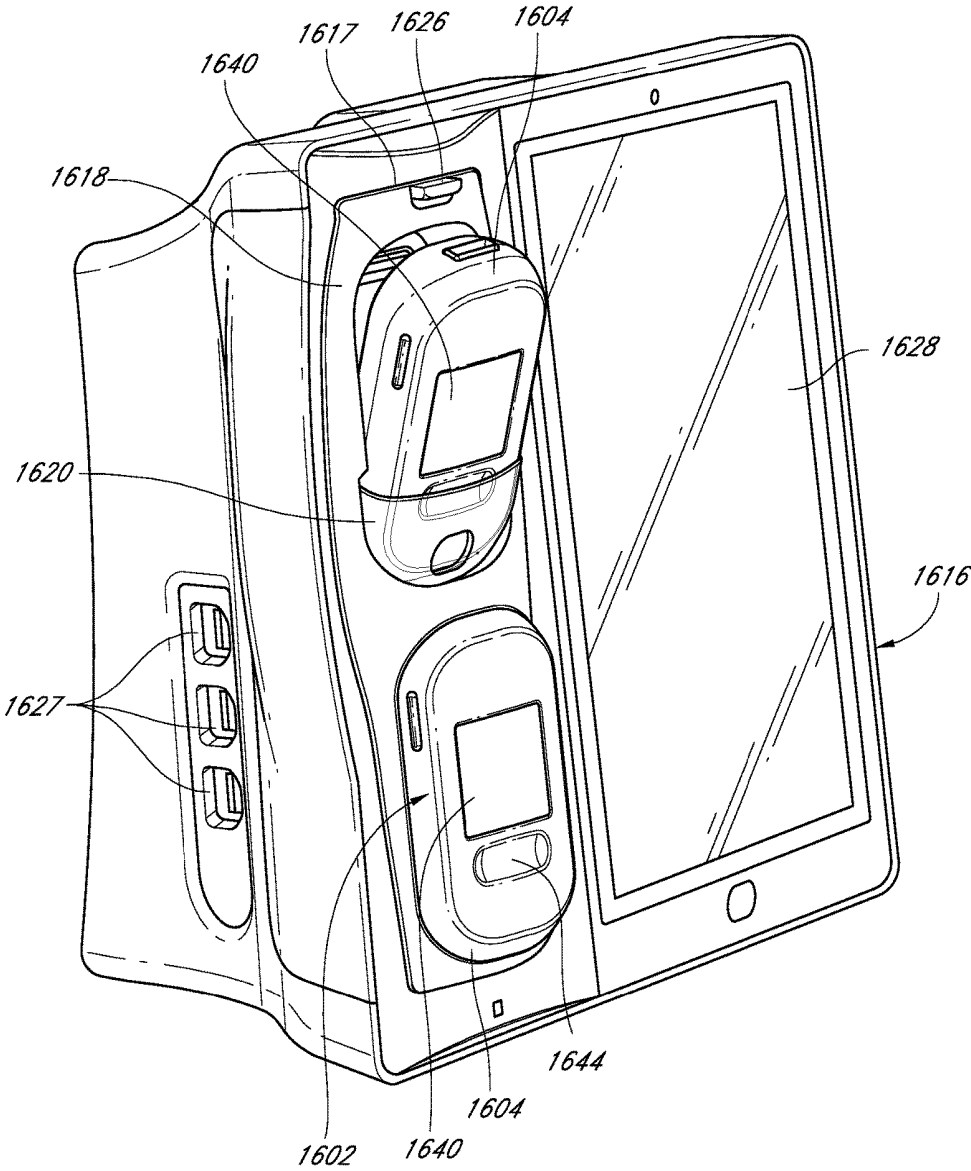

FIG. 16G

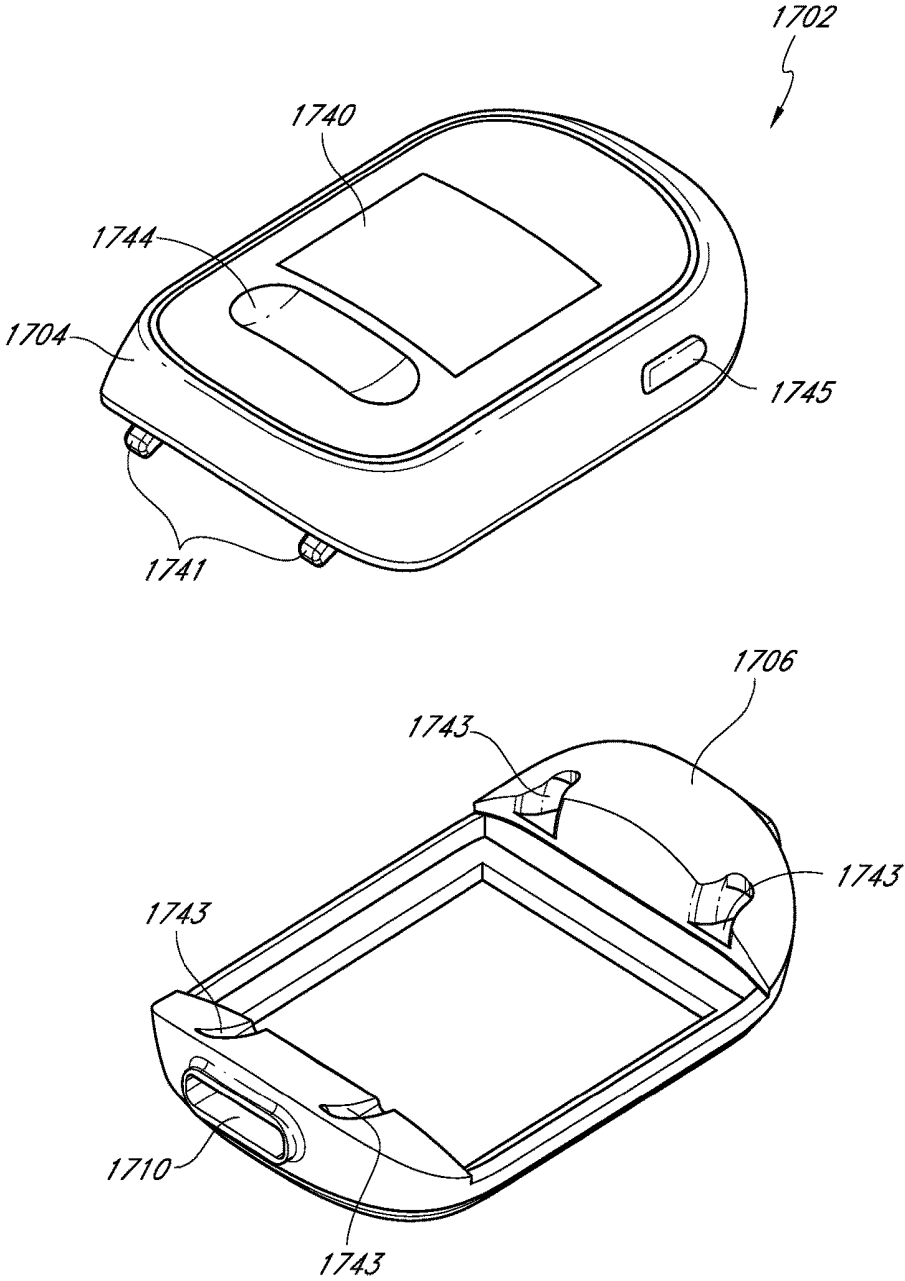

FIG. 17A

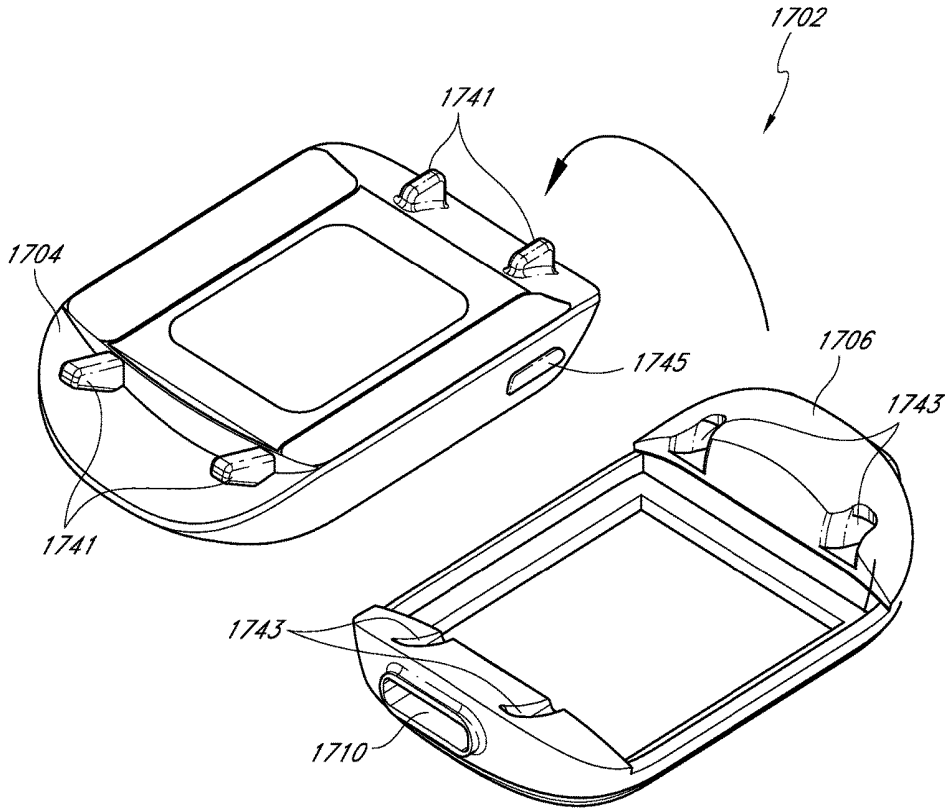

FIG. 17B

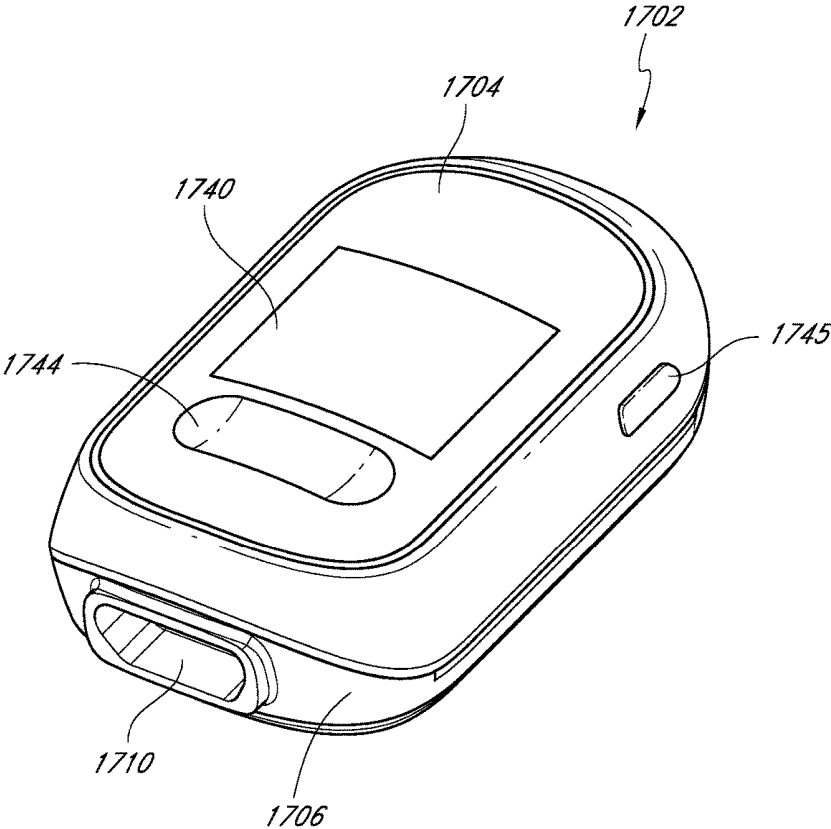

FIG. 17C

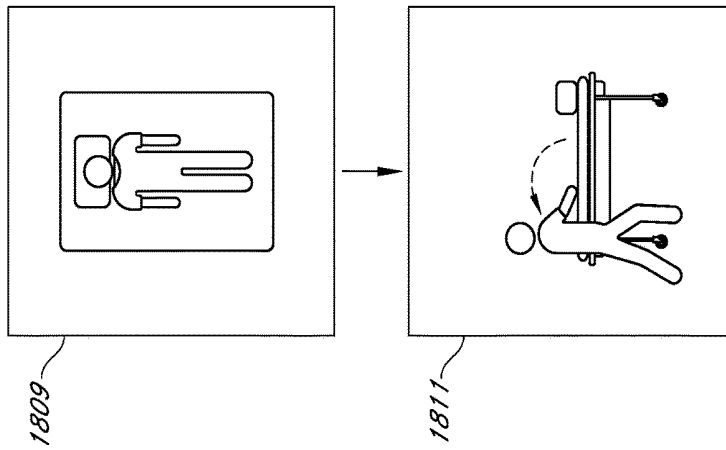

FIG. 18C

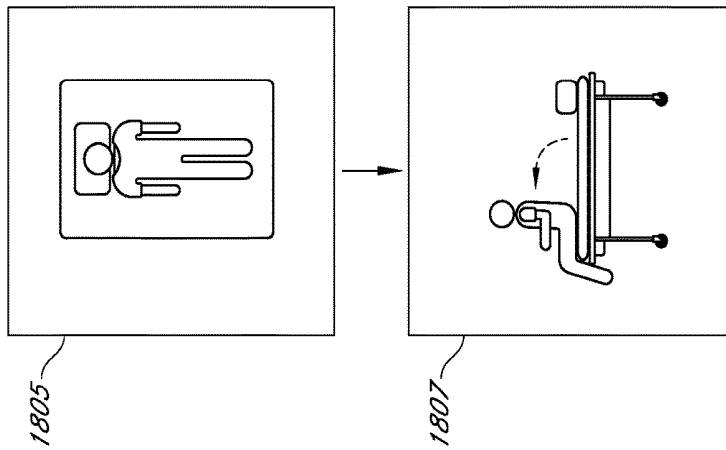

FIG. 18B

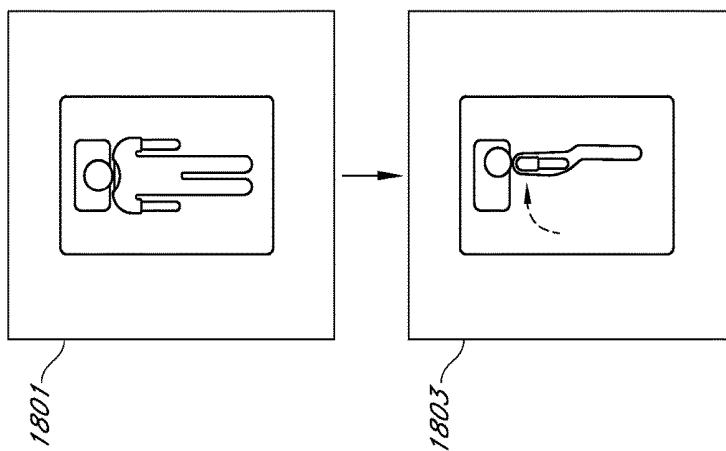

FIG. 18A

**WIRELESS PATIENT MONITORING DEVICE****CROSS-REFERENCE TO RELATED APPLICATIONS**

The present application claims priority benefit under 35 U.S.C. § 119(e) to U.S. Provisional Patent Application Ser. No. 61/597,126, filed Feb. 9, 2012, titled Wireless Patient Monitoring System, U.S. Provisional Patent Application Ser. No. 61/625,584, filed Apr. 17, 2012, titled Wireless Patient Monitoring Device, and U.S. Provisional Patent Application Ser. No. 61/703,713, filed Sep. 20, 2012, titled Wireless Patient Monitoring Device, all of which applications are hereby incorporated by reference in their entirety.

**BACKGROUND****Field**

In general, the disclosure relates to methods and apparatuses for wirelessly monitoring a patient's physiological information.

**Description of the Related Art**

Hospitals, nursing homes, and other patient care facilities typically include patient monitoring devices at one or more bedsides in the facility. Patient monitoring devices generally include sensors, processing equipment, and displays for obtaining and analyzing a medical patient's physiological parameters such as blood oxygen saturation level, respiratory rate, and the like. Clinicians, including doctors, nurses, and other medical personnel, use the physiological parameters obtained from patient monitors to diagnose illnesses and to prescribe treatments. Clinicians also use the physiological parameters to monitor patients during various clinical situations to determine whether to increase the level of medical care given to patients.

For example, the patient monitoring devices can be used to monitor a pulse oximeter. Pulse oximetry is a widely accepted noninvasive procedure for measuring the oxygen saturation level of arterial blood, an indicator of a person's oxygen supply. A typical pulse oximetry system utilizes an optical sensor clipped onto a fingertip to measure the relative volume of oxygenated hemoglobin in pulsatile arterial blood flowing within the fingertip. Oxygen saturation (SpO<sub>2</sub>), pulse rate, a plethysmograph waveform, perfusion index (PI), pleth variability index (PVI), methemoglobin (MetHb), carboxyhemoglobin (CoHb), total hemoglobin (tHb), glucose, and/or otherwise can be displayed on a monitor accordingly.

The patient monitoring devices can also communicate with an acoustic sensor comprising an acoustic transducer, such as a piezoelectric element. The acoustic sensor can detect respiratory and other biological sounds of a patient and provide signals reflecting these sounds to a patient monitor. An example of such an acoustic sensor, which can implement any of the acoustic sensing functions described herein, is described in U.S. application Ser. No. 12/643,939, filed Dec. 21, 2009, titled "Acoustic Sensor Assembly," and in U.S. application Ser. No. 61/313,645, filed Mar. 12, 2010, titled "Acoustic Respiratory Monitoring Sensor Having Multiple Sensing Elements," the disclosures of which are hereby incorporated by reference in their entirety.

Blood pressure is another example of a physiological parameter that can be monitored. Many devices allow blood pressure to be measured by sphygmomanometer systems

that utilize an inflatable cuff applied to a person's arm. The cuff is inflated to a pressure level high enough to occlude a major artery. When air is slowly released from the cuff, blood pressure can be estimated by detecting "Korotkoff" sounds using a stethoscope or other detection means placed over the artery. Other Examples of physiological parameters that can be measured include respiration rate, blood analyte measurements, such as oxygen saturation, and ECG.

**SUMMARY**

One aspect of the disclosure is a wireless patient monitoring device including one or more sensors configured to obtain physiological information. The one or more sensors can include an optical sensor, an acoustic respiratory sensor, and/or a blood pressure measurement device. Other sensors, including but not limited to, an EEG, ECG, and/or a sedation state sensor can also be used with the present disclosure. The one or more sensors are connected to a wireless monitor configured to receive the sensor data and to wirelessly transmit sensor data or physiological parameters reflective of the sensor data to a bedside monitor. The bedside monitor can be configured to output the physiological parameters, communication channel, and/or communication status.

Another aspect of the disclosure is directed toward a system configured to wirelessly communicate physiological information, the system including a battery, a housing, a rechargeable electrical storage module, and a memory module configured to store wireless communication information.

In some aspects of the disclosure, the wireless communication information stored on the data storage component facilitates communication between the wireless monitor and the bedside monitor. The information may be a unique identifier used to pair the wireless monitor with the bedside monitor. The information may be a password used to make sure only the correct receiver has access to the transmitted physiological data. The information may be channel information to make certain the wireless monitor and bedside monitor communicate on the same channel.

In some aspects of the disclosure, the bedside monitor can be configured to receive and recharge the removable battery. The battery may include a data storage component configured to store wireless communication information. In some embodiments, the bedside monitor communicates wireless communication information to the battery through a hard wired connection, and the battery stores the information. In some embodiments, the battery communicates wireless communication information to the bedside monitor through a hard wired connection.

Another aspect of the disclosure is directed toward a bedside monitor configured to receive the wireless monitor. In some embodiments, the bedside monitor communicates wireless communication information to the wireless monitor when the wireless monitor is physically and electrically connected with the bedside monitor. In some embodiments, the wireless monitor communicates information to the bedside monitor when the wireless monitor is physically and electrically connected with the bedside monitor.

In another aspect of the disclosure, the wireless monitor can be configured to transmit physiological data over a first wireless technology when a signal strength of the first wireless technology is sufficiently strong and transmit physiological data over a second wireless technology when the signal strength of the first wireless technology is not sufficiently strong.

In yet another aspect of the disclosure, the wireless monitor can be configured to transmit physiological data

over a first wireless technology when the wireless monitor is within a pre-determined distance from the wireless receiver and transmit physiological data over a second wireless technology when the wireless monitor is not within a pre-determined distance from the bedside monitor.

In another aspect of the disclosure, the battery includes a display. The display can be configured to activate when the wireless transmitter transmits physiological data over a first wireless technology and deactivate when the wireless transmitter transmits physiological data over a second wireless technology.

One aspect of the disclosure is a method of wirelessly monitoring physiological information. The method includes providing a battery including a data storage component, physically connecting the battery to a bedside monitor, storing data on the data storage component of the battery, connecting the battery to a wireless monitor, and transmitting physiological data from the wireless monitor to the bedside monitor.

In another aspect of the disclosure, transmitting physiological data from the wireless monitor to the bedside monitor includes transmitting physiological data over a first wireless technology when the wireless monitor is within a pre-determined distance from the bedside monitor and transmitting physiological data over a second wireless technology when the wireless monitor is not within a pre-determined distance from the bedside monitor. In some embodiments of the disclosure, the first wireless technology is Bluetooth or ZigBee, and the second wireless technology is Wi-Fi or cellular telephony.

In yet another aspect of the disclosure, transmitting physiological data from the wireless monitor to the bedside monitor includes transmitting physiological data over a first wireless technology when a signal strength of the first wireless technology is sufficiently strong and transmitting physiological data over a second wireless technology when the signal strength of the first wireless technology is not sufficiently strong.

In some aspects of the disclosure, the wireless monitor can be configured to be coupled to an arm band attached to the patient. Alternatively, the wireless monitor can be configured to be coupled to a patient's belt, can be carried by the patient (e.g., via a shoulder strap or handle), or can be placed on the patient's bed next to the patient, among other locations.

In another aspect of the disclosure, the wireless monitor battery includes a display screen. When the wireless monitor is within a pre-determined distance from the bedside monitor and transmits data over Bluetooth or Zigbee, the display screen deactivates. When the wireless monitor is not within a pre-determined distance from the bedside monitor and transmits data over Wi-Fi or cellular telephony, the display screen activates. Alternatively, independent of the communication protocol used by the device, when the wireless monitor is a pre-determined distance from the bedside monitor, the display screen activates. Similarly when the wireless monitor is within a pre-determined distance to the bedside monitor, the display screen deactivates.

In certain aspects of the disclosure, a blood pressure device can be used. The blood pressure device can be coupled to a medical patient and a wireless transceiver electrically coupled with the blood pressure device. The wireless transceiver can wirelessly transmit blood pressure data received by the blood pressure device and physiological data received from one or more physiological sensors coupled to the blood pressure device. To further increase

patient mobility, in some embodiments, a single cable can be provided for connecting multiple different types of sensors together.

In certain aspects of the disclosure, a wireless patient monitoring device for measuring one or more parameters can be secured to an arm of the patient. For example, a wireless measurement device for measuring oxygen saturation and respiration rate can be secured to the arm of a patient. The wireless monitoring device can connect to an oximeter probe and an acoustic respiration probe. The monitor can have a display screen and/or can transmit wireless information to a bedside monitor. In an embodiment, a docking station can be provided for the wireless monitoring device to dock it to a docking station forming a bedside monitor.

In some aspects of the disclosure, the patient monitoring devices can be coupled to a blood pressure cuff and measure blood pressure.

In some aspects of the disclosure, the patient monitoring system can include a sensor configured to obtain physiological information, an anchor connected to the sensor, and a wireless transceiver connected to the anchor. A first cable can connect the sensor to the anchor and a second cable can connect the anchor to the wireless transceiver. In certain aspects, the anchor can adhere to the patient or be carried by the patient in any manner discussed herein.

In some aspects of the disclosure, the patient monitoring system can include one or more sensors configured to obtain physiological information and a wireless transceiver configured to receive the physiological information. The wireless transceiver can include a housing having a first side and a second side. At least one connector can be positioned on the first side and at least one connector can be positioned on the second side. In certain aspects, the first side of housing can be opposite the second side of the housing.

In some aspects of the disclosure, a docking station can include a bedside monitor having a docking port configured to receive a first patient monitor and a docking station adapter configured to adapt the docking port to receive a second patient monitor. The second patient monitor can be a different size than the first patient monitor. In certain aspects, the first patient monitor can communicate with the bedside monitor over a wired connection when the first patient monitor is connected to the docking port. In certain aspects, the second patient monitor can communicate with the bedside monitor over a wired connection when the second patient monitor is connected to the docking station adapter and the docking station adapter is connected to the docking port.

In some aspects of the disclosure, a patient monitoring system can include a first sensor, a second sensor, and a wireless patient monitor configured to receive physiological information from the first sensor and the second sensor. The patient monitoring system can include a single cable connecting the first sensor and the second sensor to the wireless patient monitor. In certain aspects, the single cable can include a first cable section connecting the wireless patient monitor and the first sensor and a second cable section connecting the first sensor and the second sensor. In certain aspects, the first sensor and the second sensor can be powered by a shared power line and/or can transmit signals over a shared signal line.

In some aspects of the disclosure, a patient monitoring system can include one or more sensors configured to obtain physiological information, a patient monitor configured to receive the physiological information, and a cable hub having one or more inlet connectors connected to the one or

more sensors and an outlet connector connected to the patient monitor. In certain aspects, the one or more inlet connectors can be positioned on a first end of the cable hub and the outlet connector can be positioned on a second end of the cable hub, opposite the first end. In certain aspects, the patient monitor can include a wireless transceiver. In certain aspects, the patient monitor can be configured to be worn by the patient. In certain aspects, the cable hub can be configured to adhere to the patient. In certain aspects, a first cable extends from at least one of the one or more sensors to one of the one or more inlet connectors, and a second cable extends from the outlet connector to the patient monitor.

Some aspects of the disclosure describe a method of using a patient monitoring system. The method can include providing a wireless transceiver having a first end and a second end opposite the first end, a first connector positioned on the first end, and a second connector positioned on the second end. The method can include connecting a first end of a first cable to the first connector, and connecting a first end of a second cable to the second connector. In certain aspects, the method can include connecting a second end of the first cable to a first sensor. In certain aspects, the method can include connecting a second end of the second cable to a second sensor or a cable hub connected to one or more sensors. In certain aspects, the method can include connecting a third sensor and/or anchor to the second cable. In certain aspects, the method can include connecting a third cable to a third connector on the second end of the wireless transceiver.

Certain aspects of this disclosure are directed toward a wireless monitor including a housing, a battery, and a strap. The housing can include one or more outlets configured to receive one or more sensors. The battery can be configured to removably engage the housing. A portion of the strap can be disposed between the housing and the battery when the housing is engaged with the battery. In certain aspects, the portion of the strap disposed between the housing and the battery can be a separately formed component from a remainder of the strap. In certain aspects, the portion of the strap can include one or more mating features configured to mate with corresponding features of the housing. In certain aspects, the one or more mating features are flush with the corresponding features of the housing. In certain aspects, the housing can include a recessed portion for receiving the strap.

For purposes of summarizing the disclosure, certain aspects, advantages and novel features of the inventions have been described herein. It is to be understood that not necessarily all such advantages can be achieved in accordance with any particular embodiment of the inventions disclosed herein. Thus, the inventions disclosed herein can be embodied or carried out in a manner that achieves or optimizes one advantage or group of advantages as taught herein without necessarily achieving other advantages as can be taught or suggested herein.

#### BRIEF DESCRIPTION OF THE DRAWINGS

Various embodiments will be described hereinafter with reference to the accompanying drawings. These embodiments are illustrated and described by example only, and are not intended to limit the scope of the disclosure. In the drawings, similar elements have similar reference numerals.

FIGS. 1A and 1B illustrate embodiments of wireless patient monitoring systems.

FIGS. 1C and 1D illustrate further embodiments of wireless patient monitoring systems.

FIG. 1E illustrates the embodiment of the wireless patient monitoring system illustrated in FIGS. 1A-1B in schematic form.

FIGS. 2A and 2B illustrate embodiments of wireless patient monitoring systems having a single cable connection system.

FIGS. 3A and 3B illustrates additional embodiment of patient monitoring systems.

FIGS. 4A and 4B illustrate embodiments of an optical ear sensor and an acoustic sensor connected via a single cable connection system.

FIG. 5 illustrates an embodiment of a wireless transceiver that can be used with any of the patient monitoring systems described above.

FIGS. 6A through 6C illustrate additional embodiments of patient monitoring systems.

FIG. 7 illustrates an embodiment of a physiological parameter display that can be used with any of the patient monitoring systems described above.

FIG. 8 illustrates a further embodiment of a patient monitoring system.

FIGS. 9A-9D illustrate an embodiment of a wireless patient monitoring system.

FIG. 10 illustrates the embodiment of the wireless patient monitoring system illustrated in FIGS. 9A-9D in schematic form.

FIG. 11 illustrates one embodiment of a method of using a wireless patient monitoring system.

FIG. 12 illustrates a wireless monitor having a display screen.

FIGS. 13-15 illustrate methods of using a wireless monitor having a display screen.

FIGS. 16A-16G illustrate another embodiment of a wireless patient monitoring system.

FIGS. 17A-17C illustrate another embodiment of a wireless patient monitoring system.

FIGS. 18A-18C illustrate an animation of patient movement created using a wireless patient monitor.

#### DETAILED DESCRIPTION

In clinical settings, medical sensors are often attached to patients to monitor physiological parameters of the patients. Some examples of medical sensors include, but are not limited to, blood oxygen sensors, such as pulse oximetry sensors, acoustic respiratory sensors, EEGs, ECGs, blood pressure sensors, sedation state sensors, etc. Typically, each sensor attached to a patient is connected to a bedside monitoring device with a cable. The cables limit the patient's freedom of movement and impede a care providers access to the patient. The cables connecting the patient to the bedside monitoring device also make it more difficult to move the patient from room to room or switch to different bedside monitors.

This disclosure describes embodiments of wireless patient monitoring systems that include a wireless device coupled to a patient and to one or more sensors. In one embodiment, the wireless device transmits sensor data obtained from the sensors to a patient monitor. By transmitting the sensor data wirelessly, these patient monitoring systems can advantageously replace some or all cables that connect patients to bedside monitoring devices. To further increase patient mobility and comfort, in some embodiments, a single cable connection system is also provided for connecting multiple different types of sensors together.

These patient monitoring systems are primarily described in the context of an example blood pressure cuff that

includes a wireless transceiver. The blood pressure cuff and/or wireless transceiver can also be coupled to additional sensors, such as optical sensors, acoustic sensors, and/or electrocardiograph sensors. The wireless transceiver can transmit blood pressure data and sensor data from the other sensors to a wireless receiver, which can be a patient monitor. These and other features described herein can be applied to a variety of sensor configurations, including configurations that do not include a blood pressure cuff. In an embodiment, an arm band without a blood pressure cuff can be used to secure a wireless patient monitor connected to various sensors.

FIGS. 1A and 1B illustrate embodiments of wireless patient monitoring systems 100A, 100B, respectively. In the wireless patient monitoring systems 100 shown, a blood pressure device 110 is connected to a patient 101. The blood pressure device 110 includes a wireless transceiver 116, which can transmit sensor data obtained from the patient 101 to a wireless transceiver 120. Thus, the patient 101 is advantageously not physically coupled to a bedside monitor in the depicted embodiment and can therefore have greater freedom of movement.

Referring to FIG. 1A, the blood pressure device 110a includes an inflatable cuff 112, which can be an oscilometric cuff that is actuated electronically (e.g., via intelligent cuff inflation and/or based on a time interval) to obtain blood pressure information. The cuff 112 is coupled to a wireless transceiver 116. The blood pressure device 110a is also coupled to a fingertip optical sensor 102 via a cable 107. The optical sensor 102 can include one or more emitters and detectors for obtaining physiological information indicative of one or more blood parameters of the patient 101. These parameters can include various blood analytes such as oxygen, carbon monoxide, methemoglobin, total hemoglobin, glucose, proteins, glucose, lipids, a percentage thereof (e.g., concentration or saturation), and the like. The optical sensor 102 can also be used to obtain a photoplethysmograph, a measure of plethysmograph variability, pulse rate, a measure of blood perfusion, and the like.

Additionally, the blood pressure device 110a is coupled to an acoustic sensor 104a via a cable 105. The cable 105 connecting the acoustic sensor 104a to the blood pressure device 110 includes two portions, namely a cable 105a and a cable 105b. The cable 105a connects the acoustic sensor 104a to an anchor 104b, which is coupled to the blood pressure device 110a via the cable 105b. The anchor 104b can be adhered to the patient's skin to reduce noise due to accidental tugging of the acoustic sensor 104a.

The acoustic sensor 104a can be a piezoelectric sensor or the like that obtains physiological information reflective of one or more respiratory parameters of the patient 101. These parameters can include, for example, respiratory rate, inspiratory time, expiratory time, inspiration-to-expiration ratio, inspiratory flow, expiratory flow, tidal volume, minute volume, apnea duration, breath sounds, rales, rhonchi, stridor, and changes in breath sounds such as decreased volume or change in airflow. In addition, in some cases the respiratory sensor 104a, or another lead of the respiratory sensor 104a (not shown), can measure other physiological sounds such as heart rate (e.g., to help with probe-off detection), heart sounds (e.g., S1, S2, S3, S4, and murmurs), and changes in heart sounds such as normal to murmur or split heart sounds indicating fluid overload. In some implementations, a second acoustic respiratory sensor can be provided over the patient's 101 chest for additional heart sound detection. In one embodiment, the acoustic sensor 104 can include any of the features described in U.S. patent appli-

cation Ser. No. 12/643,939, filed Dec. 21, 2009, titled "Acoustic Sensor Assembly," the disclosure of which is hereby incorporated by reference in its entirety.

The acoustic sensor 104 can be used to generate an exciter waveform that can be detected by the optical sensor 102 at the fingertip, by an optical sensor attached to an ear of the patient (see FIGS. 2A, 3), by an ECG sensor (see FIG. 2C), or by another acoustic sensor (not shown). The velocity of the exciter waveform can be calculated by a processor (such as a processor in the wireless transceiver 120, described below). From this velocity, the processor can derive a blood pressure measurement or blood pressure estimate. The processor can output the blood pressure measurement for display. The processor can also use the blood pressure measurement to determine whether to trigger the blood pressure cuff 112.

In another embodiment, the acoustic sensor 104 placed on the upper chest can be advantageously combined with an ECG electrode (such as in structure 208 of FIG. 2B), thereby providing dual benefit of two signals generated from a single mechanical assembly. The timing relationship from fiducial markers from the ECG signal, related cardiac acoustic signal and the resulting peripheral pulse from the finger pulse oximeters produces a transit time that correlates to the cardiovascular performance such as blood pressure, vascular tone, vascular volume and cardiac mechanical function. Pulse wave transit time or PWTT in currently available systems depends on ECG as the sole reference point, but such systems may not be able to isolate the transit time variables associated to cardiac functions, such as the pre-ejection period (PEP). In certain embodiments, the addition of the cardiac acoustical signal allows isolation of the cardiac functions and provides additional cardiac performance metrics. Timing calculations can be performed by the processor in the wireless transceiver 120 or a in distributed processor found in an on-body structure (e.g., such as any of the devices herein or below: 112, 210, 230, 402, 806).

In certain embodiments, the wireless patient monitoring system 100 uses some or all of the velocity-based blood pressure measurement techniques described in U.S. Pat. No. 5,590,649, filed Apr. 15, 1994, titled "Apparatus and Method for Measuring an Induced Perturbation to Determine Blood Pressure," or in U.S. Pat. No. 5,785,659, filed Jan. 17, 1996, titled "Automatically Activated Blood Pressure Measurement Device," the disclosures of which are hereby incorporated by reference in their entirety. An example display related to such blood pressure calculations is described below with respect to FIG. 7.

The wireless transceiver 116 can transmit data using any of a variety of wireless technologies, such as Wi-Fi (802.11x), Bluetooth (802.15.2), Zigbee (802.15.4), cellular telephony, infrared, RFID, satellite transmission, proprietary protocols, combinations of the same, and the like. The wireless transceiver 116 can perform solely telemetry functions, such as measuring and reporting information about the patient 101. Alternatively, the wireless transceiver 116 can be a transceiver that also receives data and/or instructions, as will be described in further detail below.

The wireless transceiver 120 receives information from and/or sends information to the wireless transceiver 116 via an antenna 122. In certain embodiments, the wireless transceiver 120 is a patient monitor. As such, the wireless transceiver 120 can include one or more processors that process sensor signals received from the wireless transceiver 116 corresponding to the sensors 102a, 102b, 104, and/or 106 in order to derive any of the physiological parameters described above. The wireless transceiver 120 can also

display any of these parameters, including trends, waveforms, related alarms, and the like. The wireless transceiver **120** can further include a computer-readable storage medium, such as a physical storage device, for storing the physiological data. The wireless transceiver **120** can also include a network interface for communicating the physiological data to one or more hosts over a network, such as to a nurse's station computer in a hospital network.

Moreover, in certain embodiments, the wireless transceiver **116** can send raw data for processing to a central nurse's station computer, to a clinician device, and/or to a bedside device (e.g., the transceiver **116**). The wireless transceiver **116** can also send raw data to a central nurse's station computer, clinician device, and/or to a bedside device for calculation, which retransmits calculated measurements back to the blood pressure device **110** (or to the bedside device). The wireless transceiver **116** can also calculate measurements from the raw data and send the measurements to a central nurse's station computer, to a pager or other clinician device, or to a bedside device (e.g., the transceiver **116**). Many other configurations of data transmission are possible.

In addition to deriving any of the parameters mentioned above from the data obtained from the sensors **102a**, **102b**, **104**, and/or **106**, the wireless transceiver **120** can also determine various measures of data confidence, such as the data confidence indicators described in U.S. Pat. No. 7,024,233 entitled "Pulse oximetry data confidence indicator," the disclosure of which is hereby incorporated by reference in its entirety. The wireless transceiver **120** can also determine a perfusion index, such as the perfusion index described in U.S. Pat. No. 7,292,883 entitled "Physiological assessment system," the disclosure of which is hereby incorporated by reference in its entirety. Moreover, the wireless transceiver **120** can determine a plethysmograph variability index (PVI), such as the PVI described in U.S. Publication No. 2008/0188760 entitled "Plethysmograph variability processor," the disclosure of which is hereby incorporated by reference in its entirety.

In addition, the wireless transceiver **120** can send data and instructions to the wireless transceiver **116** in some embodiments. For instance, the wireless transceiver **120** can intelligently determine when to inflate the cuff **112** and can send inflation signals to the transceiver **116**. Similarly, the wireless transceiver **120** can remotely control any other sensors that can be attached to the transceiver **116** or the cuff **112**. The transceiver **120** can send software or firmware updates to the transceiver **116**. Moreover, the transceiver **120** (or the transceiver **116**) can adjust the amount of signal data transmitted by the transceiver **116** based at least in part on the acuity of the patient, using, for example, any of the techniques described in U.S. Patent Publication No. 2009/0119330, filed Jan. 7, 2009, titled "Systems and Methods for Storing, Analyzing, and Retrieving Medical Data," the disclosure of which is hereby incorporated by reference in its entirety.

In alternative embodiments, the wireless transceiver **116** can perform some or all of the patient monitor functions described above, instead of or in addition to the monitoring functions described above with respect to the wireless transceiver **120**. In some cases, the wireless transceiver **116** might also include a display that outputs data reflecting any of the parameters described above (see, e.g., FIG. 5). Thus, the wireless transceiver **116** can either send raw signal data to be processed by the wireless transceiver **120**, can send processed signal data to be displayed and/or passed on by the wireless transceiver **120**, or can perform some combination

of the above. Moreover, in some implementations, the wireless transceiver **116** can perform at least some front-end processing of the data, such as bandpass filtering, analog-to-digital conversion, and/or signal conditioning, prior to sending the data to the transceiver **120**. An alternative embodiment may include at least some front end processing embedded in any of the sensors described herein (such as sensors **102**, **104**, **204**, **202**, **208**, **412**, **804**, **840**, **808**) or cable hub **806** (see FIG. 8).

In certain embodiments, the cuff **112** is a reusable, disposable, or resposable device. Similarly, any of the sensors **102**, **104a** or cables **105**, **107** can be disposable or resposable. Resposable devices can include devices that are partially disposable and partially reusable. Thus, for example, the acoustic sensor **104a** can include reusable electronics but a disposable contact surface (such as an adhesive) where the sensor **104a** comes into contact with the patient's skin. Generally, any of the sensors, cuffs, and cables described herein can be reusable, disposable, or resposable.

The cuff **112** can also have its own power (e.g., via batteries) either as extra power or as a sole source of power for the transceiver **116**. The batteries can be disposable or reusable. In some embodiments, the cuff **112** can include one or more photovoltaic solar cells or other power sources. Likewise, batteries, solar sources, or other power sources can be provided for either of the sensors **102**, **104a**.

Referring to FIG. 1B, another embodiment of the system **100B** is shown. In the system **100B**, the blood pressure device **110b** can communicate wirelessly with the acoustic sensor **104a** and with the optical sensor **102**. For instance, wireless transceivers (not shown) can be provided in one or both of the sensors **102**, **104a**, using any of the wireless technologies described above. The wireless transceivers can transmit data using any of a variety of wireless technologies, such as Wi-Fi (802.11x), Bluetooth (802.15.2), Zigbee (802.15.4), cellular telephony, infrared, RFID, satellite transmission, proprietary protocols, combinations of the same, and the like. The wireless transceivers can transmit data, raw signals, processed signals, conditioned signals, or the like to the blood pressure device **110b**. The blood pressure device **110b** can transmit these signals on to the wireless transceiver **120**. In addition, in some embodiments, the blood pressure device **110b** can also process the signals received from the sensors **102**, **104a** prior to transmitting the signals to the wireless transceiver **120**. The sensors **102**, **104a** can also transmit data, raw signals, processed signals, conditioned signals, or the like directly to the wireless transceiver **120** or patient monitor. In one embodiment, the system **100B** shown can be considered to be a body LAN, piconet, or other individual network.

FIGS. 1C and 1D illustrate another embodiment in which a wireless monitor **150** is secured to the arm of the patient. The wireless monitor **150** is a fully functional stand-alone monitor capable of various physiological measurements. The wireless monitor is small and light enough to comfortably be secured to and carried around on the arm of a patient. In the embodiment shown in FIG. 1C, the wireless monitor **150** connects to an acoustic respiration sensor **104A** on a first side of patient monitor **150** and an oximeter sensor **102** on a second side of patient monitor **150**. This configuration of connected sensors to opposite sides of the monitor prevents cable clutter and entanglements. The wireless monitor **150** includes a screen **154**. The wireless monitor **150** couples to and is held to the arm of the patient by arm band **152**. In FIG. 1C, the arm band is not an inflatable blood pressure cuff,

however, as described with respect to the other figures, the arm band **152** can incorporate a blood pressure cuff for blood pressure readings.

The wireless monitor **150** can transmit data to a bedside monitor using any of a variety of wireless technologies, such as Wi-Fi (802.11x), Bluetooth (802.15.2), Zigbee (802.15.4), cellular telephony, infrared, RFID, satellite transmission, proprietary protocols, combinations of the same, and the like.

In an embodiment shown in FIG. 1D, the monitor **150** can be docked to a docking station **163**. The docking station **163** includes a bedside monitor **164** and docking station adapter **160**. Docking station adapter **160** adapts an otherwise incompatible docking port of bedside monitor **164** so that patient monitor **150** can dock. The docking station adapter **162** includes a port **162** for docking with the patient monitor **150**. When the patient monitor **150** is physically docked in the docking station adapter **160**, the patient monitor **150** can communicate with the bedside monitor **164** over a wired connection.

Also shown in FIG. 1D is handheld patient monitor **166**. Handheld monitor **166** is configured to dock directly to bedside monitor **164** without the need for a docking station adapter **162**. When the handheld monitor **166** is physically docked in the bedside monitor **164**, the handheld monitor **166** can communicate with the bedside monitor **164** over a wired connection.

FIG. 1E illustrates details of an embodiment of the wireless monitoring system **100A** in a schematic form. Although other types of sensors can be used, the wireless monitoring system **100A** is drawn in connection with the acoustic sensor **104a** and the optical sensor **102**. The system **100A** sends signals from the acoustic sensor **104a** and the optical sensor **102** to the sensor interface **170** and passes the signals to the DSP **172** for processing into representations of physiological parameters. In some embodiments, the DSP also communicates with a memory or information element, such as a resistor or capacitor, located on one of the sensors, such memory typically contains information related to the properties of the sensor that may be useful in processing the signals, such as, for example, emitter energy wavelengths.

In some embodiments, the physiological parameters are passed to an instrument manager **174**, which may further process the parameters for display. The instrument manager **174** may include a memory buffer **176** to maintain this data for processing throughout a period of time. Memory buffer **176** may include RAM, Flash or other solid state memory, magnetic or optical disk-based memories, combinations of the same or the like.

The wireless transceiver **120** is capable of wirelessly receiving the physiological data and/or parameters from DSP **172** or instrument manager **174**. The bedside monitor **916** can include one or more displays **178**, control buttons, a speaker for audio messages, and/or a wireless signal broadcaster. The wireless transceiver **120** can also include a processor **180** to further process the data and/or parameters for display.

FIGS. 2A and 2B illustrate additional embodiments of patient monitoring systems **200A** and **200B**, respectively. In particular, FIG. 2A illustrates a wireless patient monitoring system **200A**, while FIG. 2B illustrates a standalone patient monitoring system **200B**.

Referring specifically to FIG. 2A, a blood pressure device **210a** is connected to a patient **201**. The blood pressure device **210a** includes a wireless transceiver **216a**, which can transmit sensor data obtained from the patient **201** to a wireless transceiver at **220** via antenna **218**. The wireless

transceiver **216a** can transmit data using any of a variety of wireless technologies, such as Wi-Fi (802.11x), Bluetooth (802.15.2), Zigbee (802.15.4), cellular telephony, infrared, RFID, satellite transmission, proprietary protocols, combinations of the same, and the like.

In the depicted embodiment, the blood pressure device **210a** includes an inflatable cuff **212a**, which can include any of the features of the cuff **112** described above. Additionally, the cuff **212a** includes a pocket **214**, which holds the wireless transceiver **216a** (shown by dashed lines). The wireless transceiver **216a** can be electrically connected to the cuff **212a** via a connector (see, e.g., FIG. 5) in some embodiments. As will be described elsewhere herein, the form of attachment of the wireless transceiver **216a** to the cuff **212a** is not restricted to a pocket connection mechanism and can vary in other implementations.

The wireless transceiver **216a** is also coupled to various sensors in FIG. 2A, including an acoustic sensor **204a** and/or an optical ear sensor **202a**. The acoustic sensor **204a** can have any of the features of the acoustic sensor **104** described above. The ear clip sensor **202a** can be an optical sensor that obtains physiological information regarding one or more blood parameters of the patient **201**. These parameters can include any of the blood-related parameters described above with respect to the optical sensor **102**. In one embodiment, the ear clip sensor **202a** is an LNOPTC-I ear reusable sensor available from Masimo® Corporation of Irvine, Calif. In some embodiments, the ear clip sensor **202a** is a concha ear sensor (see FIGS. 4A and 4B).

Advantageously, in the depicted embodiment, the sensors **202a**, **204a** are coupled to the wireless transceiver **216a** via a single cable **205**. The cable **205** is shown having two sections, a cable **205a** and a cable **205b**. For example, the wireless transceiver **216a** is coupled to an acoustic sensor **204a** via the cable **205b**. In turn, the acoustic sensor **204a** is coupled to the optical ear sensor **202a** via the cable **205a**. Advantageously, because the sensors **202a**, **204a** are attached to the wireless transceiver **216a** in the cuff **212** in the depicted embodiment, the cable **205** is relatively short and can thereby increase the patient's **201** freedom of movement. Moreover, because a single cable **205** is used to connect two or more different types of sensors, such as sensors **202a**, **204a**, the patient's mobility and comfort can be further enhanced.

In some embodiments, the cable **205** is a shared cable **205** that is shared by the optical ear sensor **202a** and the acoustic sensor **204a**. The shared cable **205** can share power and ground lines for each of the sensors **202a**, **204a**. Signal lines in the cable **205** can convey signals from the sensors **202a**, **204a** to the wireless transceiver **216a** and/or instructions from the wireless transceiver **216a** to the sensors **202a**, **204a**. The signal lines can be separate within the cable **205** for the different sensors **202a**, **204a**. Alternatively, the signal lines can be shared as well, forming an electrical bus.

The two cables **205a**, **205b** can be part of a single cable or can be separate cables **205a**, **205b**. As a single cable **205**, in one embodiment, the cable **205a**, **205b** can connect to the acoustic sensor **204a** via a single connector. As separate cables, in one embodiment, the cable **205b** can be connected to a first port on the acoustic sensor **204a** and the cable **205a** can be coupled to a second port on the acoustic sensor **204a**.

FIG. 2B further illustrates an embodiment of the cable **205** in the context of a standalone patient monitoring system **200B**. In the standalone patient monitoring system **200B**, a blood pressure device **210b** is provided that includes a patient monitor **216b** disposed on a cuff **212b**. The patient monitor **216b** includes a display **219** for outputting physi-

ological parameter measurements, trends, waveforms, patient data, and optionally other data for presentation to a clinician. The display **219** can be an LCD display, for example, with a touch screen or the like. The patient monitor **216b** can act as a standalone device, not needing to communicate with other devices to process and measure physiological parameters. In some embodiments, the patient monitor **216b** can also include any of the wireless functionality described above. For example, the patient monitor **216b** can transmit data using any of a variety of wireless technologies, such as Wi-Fi (802.11x), Bluetooth (802.15.2), Zigbee (802.15.4), cellular telephony, infrared, RFID, satellite transmission, proprietary protocols, combinations of the same, and the like.

The patient monitor **216b** can be integrated into the cuff **212b** or can be detachable from the cuff **212b**. In one embodiment, the patient monitor **216b** can be a readily available mobile computing device with a patient monitoring software application. For example, the patient monitor **216b** can be a smart phone, personal digital assistant (PDA), or other wireless device. The patient monitoring software application on the device can perform any of a variety of functions, such as calculating physiological parameters, displaying physiological data, documenting physiological data, and/or wirelessly transmitting physiological data (including measurements or uncalculated raw sensor data) via email, text message (e.g., SMS or MMS), or some other communication medium. Moreover, any of the wireless transceivers or patient monitors described herein can be substituted with such a mobile computing device.

In the depicted embodiment, the patient monitor **216b** is connected to three different types of sensors. An optical sensor **202b**, coupled to a patient's **201** finger, is connected to the patient monitor **216b** via a cable **207**. In addition, an acoustic sensor **204b** and an electrocardiograph (ECG) sensor **206** are attached to the patient monitor **206b** via the cable **205**. The optical sensor **202b** can perform any of the optical sensor functions described above. Likewise, the acoustic sensor **204b** can perform any of the acoustic sensor functions described above. The ECG sensor **206** can be used to monitor electrical activity of the patient's **201** heart.

Advantageously, in the depicted embodiment, the ECG sensor **206** is a bundle sensor that includes one or more ECG leads **208** in a single package. For example, the ECG sensor **206** can include one, two, or three or more leads. One or more of the leads **208** can be an active lead or leads, while another lead **208** can be a reference lead. Other configurations are possible with additional leads within the same package or at different points on the patient's body. Using a bundle ECG sensor **206** can advantageously enable a single cable connection via the cable **205** to the cuff **212b**. Similarly, an acoustical sensor can be included in the ECG sensor **206** to advantageously reduce the overall complexity of the on-body assembly.

The cable **205a** in FIG. 2B can connect two sensors to the cuff **212b**, namely the ECG sensor **206** and the acoustic sensor **204b**. Although not shown, the cable **205a** can further connect an optical ear sensor to the acoustic sensor **204b** in some embodiments, optionally replacing the finger optical sensor **202b**. The cable **205a** shown in FIG. 2B can have all the features described above with respect to cable **205a** of FIG. 2A.

Although not shown, in some embodiments, any of the sensors, cuffs, wireless sensors, or patient monitors described herein can include one or more accelerometers or other motion measurement devices (such as gyroscopes). For example, in FIG. 2B, one or more of the acoustic sensor

**204b**, the ECG sensor **206**, the cuff **212b**, the patient monitor **216b**, and/or the optical sensor **202b** can include one or more motion measurement devices. A motion measurement device can be used by a processor (such as in the patient monitor **216b** or other device) to determine motion and/or position of a patient. For example, a motion measurement device can be used to determine whether a patient is sitting up, lying down, walking, or the like.

Movement and/or position data obtained from a motion measurement device can be used to adjust a parameter calculation algorithm to compensate for the patient's motion. For example, a parameter measurement algorithm that compensates for motion can more aggressively compensate for motion in response to high degree of measured movement. When less motion is detected, the algorithm can compensate less aggressively. Movement and/or position data can also be used as a contributing factor to adjusting parameter measurements. Blood pressure, for instance, can change during patient motion due to changes in blood flow. If the patient is detected to be moving, the patient's calculated blood pressure (or other parameter) can therefore be adjusted differently than when the patient is detected to be sitting.

A database can be assembled that includes movement and parameter data (raw or measured parameters) for one or more patients over time. The database can be analyzed by a processor to detect trends that can be used to perform parameter calculation adjustments based on motion or position. Many other variations and uses of the motion and/or position data are possible.

Although the patient monitoring systems described herein, including the systems **100A**, **100B**, **200A**, and **200B** have been described in the context of blood pressure cuffs, blood pressure need not be measured in some embodiments. For example, the cuff can be a holder for the patient monitoring devices and/or wireless transceivers and not include any blood pressure measuring functionality. Further, the patient monitoring devices and/or wireless transceivers shown need not be coupled to the patient via a cuff, but can be coupled to the patient at any other location, including not at all. For example, the devices can be coupled to the patient's belt (see FIGS. 3A and 3B), can be carried by the patient (e.g., via a shoulder strap or handle), or can be placed on the patient's bed next to the patient, among other possible locations.

Additionally, various features shown in FIGS. 2A and 2B can be changed or omitted. For instance, the wireless transceiver **216a** can be attached to the cuff **212** without the use of the pocket **214**. For example, the wireless transceiver can be sewn, glued, buttoned or otherwise attached to the cuff using any various known attachment mechanisms. Or, the wireless transceiver **216a** can be directly coupled to the patient (e.g., via an armband) and the cuff **212** can be omitted entirely. Instead of a cuff, the wireless transceiver **216a** can be coupled to a non-occlusive blood pressure device. Many other configurations are possible.

FIGS. 3A and 3B illustrate further embodiments of a patient monitoring system **300A**, **300B** having a single cable connecting multiple sensors. FIG. 3A depicts a tethered patient monitoring system **300A**, while FIG. 3B depicts a wireless patient monitoring system **300B**. The patient monitoring systems **300A**, **300B** illustrate example embodiments where a single cable **305** can be used to connect multiple sensors, without using a blood pressure cuff.

Referring to FIG. 3A, the acoustic and ECG sensors **204b**, **206** of FIG. 2 are again shown coupled to the patient **201**. As above, these sensors **204b**, **206** are coupled together via a

cable 205. However, the cable 250 is coupled to a junction device 230a instead of to a blood pressure cuff. In addition, the optical sensor 202b is coupled to the patient 201 and to the junction device 230a via a cable 207. The junction device 230a can anchor the cable 205b to the patient 201 (such as via the patient's belt) and pass through any signals received from the sensors 202b, 204b, 206 to a patient monitor 240 via a single cable 232.

In some embodiments, however, the junction device 230a can include at least some front-end signal processing circuitry. In some embodiments, the junction device 230a also includes a processor for processing physiological parameter measurements. Further, the junction device 230a can include all the features of the patient monitor 216b in some embodiments, such as providing a display that outputs parameters measured from data obtained by the sensors 202b, 204b, 206.

In the depicted embodiment, the patient monitor 240 is connected to a medical stand 250. The patient monitor 240 includes parameter measuring modules 242, one of which is connected to the junction device 230a via the cable 232. The patient monitor 240 further includes a display 246. The display 246 is a user-rotatable display in the depicted embodiment.

Referring to FIG. 3B, the patient monitoring system 300B includes nearly identical features to the patient monitoring system 300A. However, the junction device 230b includes wireless capability, enabling the junction device 230b to wirelessly communicate with the patient monitor 240 and/or other devices. The wireless patient monitoring system 300B can transmit data using any of a variety of wireless technologies, such as Wi-Fi (802.11x), Bluetooth (802.15.2), Zigbee (802.15.4), cellular telephony, infrared, RFID, satellite transmission, proprietary protocols, combinations of the same, and the like.

FIGS. 4A and 4B illustrate embodiments of patient monitoring systems 400A, 400B that depict alternative cable connection systems 410 for connecting sensors to a patient monitor 402. Like the cable 205 described above, these cable connection systems 410 can advantageously enhance patient mobility and comfort.

Referring to FIG. 4A, the patient monitoring system 400A includes a patient monitor 402a that measures physiological parameters based on signals obtained from sensors 412, 420 coupled to a patient. These sensors include an optical ear sensor 412 and an acoustic sensor 420 in the embodiment shown. The optical ear sensor 412 can include any of the features of the optical sensors described above. Likewise, the acoustic sensor 420 can include any of the features of the acoustic sensors described above.

The optical ear sensor 412 can be shaped to conform to the cartilaginous structures of the ear, such that the cartilaginous structures can provide additional support to the sensor 412, providing a more secure connection. This connection can be particularly beneficial for monitoring during pre-hospital and emergency use where the patient can move or be moved. In some embodiments, the optical ear sensor 412 can have any of the features described in U.S. application Ser. No. 12/658,872, filed Feb. 16, 2010, entitled "Ear Sensor," the disclosure of which is hereby incorporated by reference in its entirety.

An instrument cable 450 connects the patient monitor 402a to the cable connection system 410. The cable connection system 410 includes a sensor cable 440 connected to the instrument cable 250. The sensor cable 440 is bifurcated into two cable sections 416, 422, which connect to the individual sensors 412, 420 respectively. An anchor 430a

connects the sensor cable 440 and cable sections 416, 422. The anchor 430a can include an adhesive for anchoring the cable connection system 410 to the patient, so as to reduce noise from cable movement or the like. Advantageously, the cable connection system 410 can reduce the number and size of cables connecting the patient to a patient monitor 402a. The cable connection system 410 can also be used to connect with any of the other sensors, patient-worn monitors, or wireless devices described above.

FIG. 4B illustrates the patient monitoring system 400B, which includes many of the features of the monitoring system 400A. For example, an optical ear sensor 412 and an acoustic sensor 420 are coupled to the patient. Likewise, the cable connection system 410 is shown, including the cable sections 416, 422 coupled to an anchor 430b. In the depicted embodiment, the cable connection system 410 communicates wirelessly with a patient monitor 402b. For example, the anchor 430b can include a wireless transceiver, or a separate wireless dongle or other device (not shown) can couple to the anchor 430b. The anchor 430b can be connected to a blood pressure cuff, wireless transceiver, junction device, or other device in some embodiments. The wireless transceiver, wireless dongle, or other device can transmit data using any of a variety of wireless technologies, such as Wi-Fi (802.11x), Bluetooth (802.15.2), Zigbee (802.15.4), cellular telephony, infrared, RFID, satellite transmission, proprietary protocols, combinations of the same, and the like.

FIG. 5 illustrates a more detailed embodiment of a wireless transceiver 516. The wireless transceiver 516 can have all of the features of the wireless transceiver 516 described above. For example, the wireless transceiver 516 can connect to a blood pressure cuff and to one or more physiological sensors, and the transceiver 516 can transmit sensor data to a wireless receiver. The wireless transceiver 516 can transmit data using any of a variety of wireless technologies, such as Wi-Fi (802.11x), Bluetooth (802.15.2), Zigbee (802.15.4), cellular telephony, infrared, RFID, satellite transmission, proprietary protocols, combinations of the same, and the like.

The depicted embodiment of the transceiver 516 includes a housing 530, which includes connectors 552 for sensor cables (e.g., for optical, acoustic, ECG, and/or other sensors) and a connector 560 for attachment to a blood pressure cuff or other patient-wearable device. The transceiver 516 further includes an antenna 518, which although shown as an external antenna, can be internal in some implementations.

The transceiver 516 can include one or more connectors on one or more sides of the housing 530. Providing connectors on different sides of the housing 530 allows for convenient sensor connection and prevents the sensor cables from tangling. For example, as shown in FIG. 5, the housing can include two connectors 552 on a first side of the housing 530 and an additional connector 560 on a second side of the housing 530.

In addition, the transceiver 516 includes a display 554 that depicts values of various parameters, such as systolic and diastolic blood pressure, SpO<sub>2</sub>, and respiratory rate (RR). The display 554 can also display trends, alarms, and the like. The transceiver 516 can be implemented with the display 554 in embodiments where the transceiver 516 also acts as a patient monitor. The transceiver 516 further includes controls 556, which can be used to manipulate settings and functions of the transceiver 516.

FIGS. 6A through 6C illustrate embodiments of wireless patient monitoring systems 600. These wireless patient monitoring systems can transmit data using any of a variety

of wireless technologies, such as Wi-Fi (802.11x), Bluetooth (802.15.2), Zigbee (802.15.4), cellular telephony, infrared, RFID, satellite transmission, proprietary protocols, combinations of the same, and the like.

FIG. 6A illustrates a patient monitoring system 600A that includes a wireless transceiver 616, which can include the features of any of the transceivers 116, 216a described above. The transceiver 616 provides a wireless signal over a wireless link 612 to a patient monitor 620. The wireless signal can include physiological information obtained from one or more sensors, physiological information that has been front-end processed by the transceiver 616, or the like.

The patient monitor 620 can act as the wireless transceiver 220 of FIG. 2. The patient monitor 620 can process the wireless signal received from the transceiver 616 to obtain values, waveforms, and the like for one or more physiological parameters. The patient monitor 620 can perform any of the patient monitoring functions described above with respect to FIGS. 2 through 5.

In addition, the patient monitor 620 can provide at least some of the physiological information received from the transceiver 616 to a multi-patient monitoring system (MMS) 640 over a network 630. The MMS 640 can include one or more physical computing devices, such as servers, having hardware and/or software for providing the physiological information to other devices in the network 630. For example, the MMS 640 can use standardized protocols (such as TCP/IP) or proprietary protocols to communicate the physiological information to one or more nurses' station computers (not shown) and/or clinician devices (not shown) via the network 630. In one embodiment, the MMS 640 can include some or all the features of the MMS described in U.S. Publication No. 2008/0188760, referred to above.

The network 630 can be a LAN or WAN, wireless LAN ("WLAN"), or other type of network used in any hospital, nursing home, patient care center, or other clinical location. In some implementations, the network 210 can interconnect devices from multiple hospitals or clinical locations, which can be remote from one another, through the Internet, one or more Intranets, a leased line, or the like. Thus, the MMS 640 can advantageously distribute the physiological information to a variety of devices that are geographically co-located or geographically separated.

FIG. 6B illustrates another embodiment of a patient monitoring system 600B, where the transceiver 616 transmits physiological information to a base station 624 via the wireless link 612. In this embodiment, the transceiver 616 can perform the functions of a patient monitor, such as any of the patient monitor functions described above. The transceiver 616 can provide processed sensor signals to the base station 624, which forwards the information on to the MMS 640 over the network 630.

FIG. 6C illustrates yet another embodiment of a patient monitoring system 600B, where the transceiver 616 transmits physiological information directly to the MMS 640. The MMS 640 can include wireless receiver functionality, for example. Thus, the embodiments shown in FIGS. 6A through 6C illustrate that the transceiver 616 can communicate with a variety of different types of devices.

FIG. 7 illustrates an embodiment of a physiological parameter display 700. The physiological parameter display 700 can be output by any of the systems described above. For instance, the physiological parameter display 700 can be output by any of the wireless receivers, transceivers, or patient monitors described above. The parameter display 700 can be output over a variety of wireless technologies, such as Wi-Fi (802.11x), Bluetooth (802.15.2), Zigbee

(802.15.4), cellular telephony, infrared, RFID, satellite transmission, proprietary protocols, combinations of the same, and the like. Advantageously, in certain embodiments, the physiological parameter display 700 can display multiple parameters, including noninvasive blood pressure (NIBP) obtained using both oscillometric and non-oscillometric techniques.

The physiological parameter display 700 can display any of the physiological parameters described above, to name a few. In the depicted embodiment, the physiological parameter display 700 is shown displaying oxygen saturation 702, heart rate 704, and respiratory rate 706. In addition, the physiological parameter display 700 displays blood pressure 708, including systolic and diastolic blood pressure.

The display 700 further shows a plot 710 of continuous or substantially continuous blood pressure values measured over time. The plot 710 includes a trace 712a for systolic pressure and a trace 712b for diastolic pressure. The traces 712a, 712b can be generated using a variety of devices and techniques. For instance, the traces 712a, 712b can be generated using any of the velocity-based continuous blood pressure measurement techniques described above and described in further detail in U.S. Pat. Nos. 5,590,649 and 5,785,659, referred to above.

Periodically, oscillometric blood pressure measurements (sometimes referred to as Gold Standard NIBP) can be taken, using any of the cuffs described above. These measurements are shown by markers 714 on the plot 710. By way of illustration, the markers 714 are "X's" in the depicted embodiment, but the type of marker 714 used can be different in other implementations. In certain embodiments, oscillometric blood pressure measurements are taken at predefined intervals, resulting in the measurements shown by the markers 714.

In addition to or instead of taking these measurements at intervals, oscillometric blood pressure measurements can be triggered using ICI techniques, e.g., based at least partly on an analysis of the noninvasive blood pressure measurements indicated by the traces 712a, 712b. Advantageously, by showing both types of noninvasive blood pressure measurements in the plot 710, the display 700 can provide a clinician with continuous and oscillometric blood pressure information.

FIG. 8 illustrates another embodiment of a patient monitoring system 800. The features of the patient monitoring system 800 can be combined with any of the features of the systems described above. Likewise, any of the features described above can be incorporated into the patient monitoring system 800. Advantageously, in the depicted embodiment, the patient monitoring system 800 includes a cable hub 806 that enables one or many sensors to be selectively connected and disconnected to the cable hub 806.

Like the patient monitoring systems described above, the monitoring system 800 includes a cuff 810 with a patient device 816 for providing physiological information to a monitor 820 or which can receive power from a power supply (820). The cuff 810 can be a blood pressure cuff or merely a holder for the patient device 816. The patient device 816 can instead be a wireless transceiver having all the features of the wireless devices described above. The wireless transceiver can transmit data using any of a variety of wireless technologies, such as Wi-Fi (802.11x), Bluetooth (802.15.2), Zigbee (802.15.4), cellular telephony, infrared, RFID, satellite transmission, proprietary protocols, combinations of the same, and the like.

The patient device 816 is in coupled with an optical finger sensor 802 via cable 807. Further, the patient device 816 is

coupled with the cable hub **806** via a cable **805a**. The cable hub **806** can be selectively connected to one or more sensors. In the depicted embodiment, example sensors shown coupled to the cable hub **806** include an ECG sensor **808a** and a brain sensor **840**. The ECG sensor **808a** can be single-lead or multi-lead sensor. The brain sensor **840** can be an electroencephalography (EEG) sensor and/or an optical sensor. An example of EEG sensor that can be used as the brain sensor **840** is the SEDLine™ sensor available from Masimo® Corporation of Irvine, Calif., which can be used for depth-of-anesthesia monitoring among other uses. Optical brain sensors can perform spectrophotometric measurements using, for example, reflectance pulse oximetry. The brain sensor **840** can incorporate both an EEG/depth-of-anesthesia sensor and an optical sensor for cerebral oximetry.

The ECG sensor **808a** is coupled to an acoustic sensor **804** and one or more additional ECG leads **808b**. For illustrative purposes, four additional leads **808b** are shown, for a 5-lead ECG configuration. In some embodiments, one or two additional leads **808b** are used instead of four additional leads. In some embodiments, up to at least 12 leads **808b** can be included. Acoustic sensors can also be disposed in the ECG sensor **808a** and/or lead(s) **808b** or on other locations of the body, such as over a patient's stomach (e.g., to detect bowel sounds, thereby verifying patient's digestive health, for example, in preparation for discharge from a hospital). Further, in some embodiments, the acoustic sensor **804** can connect directly to the cable hub **806** instead of to the ECG sensor **808a**.

As mentioned above, the cable hub **806** can enable one or many sensors to be selectively connected and disconnected to the cable hub **806**. This configurability aspect of the cable hub **806** can allow different sensors to be attached or removed from a patient based on the patient's monitoring needs, without coupling new cables to the monitor **820**. Instead, a single, light-weight cable **832** couples to the monitor **820** in certain embodiments, or wireless technology can be used to communicate with the monitor **820** (see, e.g., FIG. 1). A patient's monitoring needs can change as the patient is moved from one area of a care facility to another, such as from an operating room or intensive care unit to a general floor. The cable configuration shown, including the cable hub **806**, can allow the patient to be disconnected from a single cable to the monitor **820** and easily moved to another room, where a new monitor can be coupled to the patient. Of course, the monitor **820** may move with the patient from room to room, but the single cable connection **832** rather than several can facilitate easier patient transport.

Further, in some embodiments, the cuff **810** and/or patient device **816** need not be included, but the cable hub **806** can instead connect directly to the monitor wirelessly or via a cable. Additionally, the cable hub **806** or the patient device **816** may include electronics for front-end processing, digitizing, or signal processing for one or more sensors. Placing front-end signal conditioning and/or analog-to-digital conversion circuitry in one or more of these devices can make it possible to send continuous waveforms wirelessly and/or allow for a small, more user-friendly wire (and hence cable **832**) routing to the monitor **820**.

The cable hub **806** can also be attached to the patient via an adhesive, allowing the cable hub **806** to become a wearable component. Together, the various sensors, cables, and cable hub **806** shown can be a complete body-worn patient monitoring system. The body-worn patient monitoring system can communicate with a patient monitor **820** as

shown, which can be a tablet, handheld device, a hardware module, or a traditional monitor with a large display, to name a few possible devices.

FIGS. 9A-9D illustrate another embodiment of a wireless monitoring system **900** including a wireless monitor **902** coupled to a sensor **930**. The wireless monitoring system **900** is configured to connect to one or more sensors and/or a bedside monitor. The features of the wireless monitoring system **900** can be combined with any of the features of the systems described above. Likewise, any of the features described above can be incorporated into the patient monitoring system **900**. The wireless monitor **902** includes a removable battery **904** having a data storage component. The removable battery **904** can be used to pair the wireless monitor **902** with the correct bedside monitor as described below. The battery **904** is positioned on the front side of the wireless monitor **902**, so the battery **904** can be replaced without disconnecting a wireless monitor housing from the patient. Further details of these drawings are described below.

FIG. 10 illustrates details of an embodiment of the wireless monitoring system **900** in a schematic form. Typically, the sensor **930** includes energy emitters **1016** located on one side of a patient monitoring site **1018** and one or more detectors **1020** located generally opposite. The patient monitoring site **1018** is usually a patient's finger (as pictured), toe, ear lobe, or the like. Energy emitters **1016**, such as LEDs, emit particular wavelengths of energy through the flesh of a patient at the monitoring site **1018**, which attenuates the energy. The detector(s) **1020** then detect the attenuated energy and send representative signals to the wireless monitor **902**.

The wireless monitor **902** can include a sensor interface **1024** and a digital signal processor (DSP) **1026**. The sensor interface **1024** receives the signals from the sensor **930** detector(s) **1020** and passes the signals to the DSP **1026** for processing into representations of physiological parameters. In some embodiments, the DSP **1026** also communicates with a memory or information element, such as a resistor or capacitor, **1030** located on the sensor **930**, such memory typically contains information related to the properties of the sensor that may be useful in processing the signals, such as, for example, emitter **1016** energy wavelengths.

In some embodiments, the physiological parameters are passed to an instrument manager **1028**, which may further process the parameters for display by a bedside monitor **916**. The instrument manager **1028** may include a memory buffer **1034** to maintain this data for processing throughout a period of time. Memory buffer **1034** may include RAM, Flash or other solid state memory, magnetic or optical disk-based memories, combinations of the same or the like.

In some embodiments, the wireless monitor is able to display one or more physiological parameters. The wireless monitor **902** can include one or more displays **1036**, control buttons **1040**, one or more speakers **1038** for audio messages. Control buttons **1040** may comprise a keypad, a full keyboard, a touch screen, a track wheel, and the like.

The wireless monitor **902** is powered by a battery **904**. In some embodiments, the battery **904** directly or indirectly powers the sensor interface **1024**, DSP **1026**, and the instrument manager **1028**.

The battery **904** includes memory **932**, such memory stores wireless communication information needed for the wireless monitor **902** to wirelessly communicate with bedside monitor **916**. The battery **904** can communicate the information stored on the memory **932** to the wireless

monitor **902** or bedside monitor **916**, and the memory **932** can store information received from the wireless monitor **902** or bedside monitor **916**.

The bedside monitor **916** wirelessly receives the physiological data and/or parameters from the wireless monitor **902** and is able to display one or more physiological parameters. The bedside monitor **916** can include one or more displays **1008**, control buttons **1010**, a speaker **1012** for audio messages, and/or a wireless signal broadcaster. Control buttons **1010** may comprise a keypad, a full keyboard, a track wheel, and the like.

As shown in FIG. **10**, the wireless monitor **902** can include an optional internal battery **905** capable of powering the wireless monitor **902** when the battery **904** is disconnected from the wireless monitor **902**. The internal battery **905** can include additional backup memory **933** to store information when the battery **904** is disconnected from the wireless monitor **902**. The internal battery **905** can be useful when a caregiver replaces the battery **904** with a different, fully-charged battery. While the battery **904** is disconnected from the wireless monitor **902**, the wireless monitor **902** can continue to display and communicate information.

In several embodiments, the wireless patient monitoring system includes one or more sensors, including, but not limited to, a sensor **930** to monitor oxygen saturation and pulse rate. These physiological parameters can be measured using a pulse oximeter. In general, the sensor **930** has light emitting diodes that transmit optical radiation of red and infrared wavelengths into a tissue site and a detector that responds to the intensity of the optical radiation after absorption (e.g. by transmission or transreflectance) by pulsatile arterial blood flowing within the tissue site. Based on this response, a processor determines measurements for SpO<sub>2</sub>, pulse rate, and can output representative plethsmographic waveforms. Thus, "pulse oximetry" as used herein encompasses its broad ordinary meaning known to one of skill in the art, which includes at least those noninvasive procedures for measuring parameters of circulating blood through spectroscopy.

The wireless monitoring system **900** can include any of the sensors described herein in addition to or in alternative to the pulse oximeter. For example, the wireless monitoring system **900** can also include sensors for monitoring acoustics, sedation state, blood pressure, ECG, body temperature, and/or cardiac output. The wireless monitor may also include an accelerometer or gyroscope. The wireless patient monitoring system may include any of the above-mentioned sensors alone or in combination with each other.

In several embodiments, the wireless monitor **902** includes a wireless transmitter to transmit sensor data and/or a wireless receiver to receive data from another wireless transmitter or transceiver. By transmitting the sensor data wirelessly, the wireless monitor **902** can advantageously replace some or all cables that connect patients to bedside monitoring devices. Alternatively, the wireless monitor **902** calculates physiological parameters based on the sensor data and wirelessly transmits the physiological parameters and/or the sensor data itself to the bedside monitor. The physiological parameter can be numerical information, such as oxygen saturation (SpO<sub>2</sub>) or pulse rate, or a graphical depiction of the sensor data. The data processors can be positioned in the wireless monitor housing or the battery. By configuring the wireless monitor **902** to calculate the physiological parameter, less data transfer is required to transmit information from the wireless monitor to the bedside monitor. Processing the sensor data in the wireless monitor **902** also improves the quality of the signal transferred to the bedside monitor.

As shown in FIGS. **9B-9C**, the wireless monitor **902** includes a removable battery **904** and a base **906**. The base **906** can include processing and wireless transmission capabilities and/or share processing function with the battery **904**. Removable battery **904** includes a release mechanism **912** to release the battery **904** from the base **906**. As depicted in FIG. **9B**, the base **906** can include a battery receiving portion **914** and a notch **917** to lock the removable battery **904** in place. Wireless monitor **902** can have one or more outlets **910** to plug in the sensor **930**, such as the pulse oximeter, acoustic respiratory sensor, ECG, sedation sensor, blood pressure cuff, or any other sensor. In some embodiments, one or more outlets **910** can be positioned on one or more sides of the wireless monitor **902**. For example, the wireless monitor can include an outlet on one side for an acoustic respiratory sensor and an outlet on an opposite side for a pulse oximeter.

Wireless monitor **902** can include an opening **908** through which an arm band **934** can be passed to secure the wireless monitor **902** to the arm of the patient, as shown in FIG. **9A**. The arm band **934** can be reusable, disposable or resposable. Similarly, any of the sensors **930** can be disposable or resposable. Resposable devices can include devices that are partially disposable and partially reusable. Thus, for example, the acoustic sensor can include reusable electronics, but a disposable contact surface (such as an adhesive) where the sensor comes into contact with the patient's skin.

The sensors **930** and/or wireless monitor **902** need not be worn around the patient's arm, but can be worn at any other location, including not at all. The sensors **930** and/or wireless monitor **902** need not be coupled to an arm band, but can be coupled to a patient's belt or a chest strap, can be carried by the patient (e.g., via a shoulder strap or handle), or can be placed on the patient's bed next to the patient, among other locations.

FIG. **9D** illustrates the battery **904** docked with a bedside monitor **916**. Bedside monitor **916** has a battery charging station **922** for receiving and charging removable battery **904**. When the wireless monitor **902** is using a first battery, the battery charging station **922** can charge a second battery, so when the battery levels of the first battery are low, a second battery is readily available. Each battery is capable of powering the wireless monitor **902** for at least one nursing shift, so each nurse only has to replace the battery once either at the beginning or end of each shift.

An adaptor **918** can be integrated with the bedside monitor or separately connected to bedside monitor **916**. The bedside monitor **916** includes a release mechanism **926** to release the adaptor **918** from the bedside monitor **916**. Adaptor **918** includes docking station **920** to receive the entire wireless monitor (not shown). Locking mechanism **924** holds the wireless monitor **902** in place. Other components may be connected to the bedside monitor **916** instead of the adaptor **918**, such as a handheld patient monitor device.

In some embodiments, the adaptor **918** includes a docking station **920** to receive the entire wireless monitor **902**. The wireless monitor **902** can be placed in the docking station **920** when it is not in use to prevent the wireless monitor **902** from being lost. The bedside monitor **916** can charge the battery **904** when the wireless monitor **902** is connected to the bedside monitor **916**. In certain aspects, the bedside monitor **916** can communicate a password, unique identifier, appropriate channel information, or other wireless communication information to the wireless monitor **902**, and vice versa, when the wireless monitor **902** is connected to the bedside monitor **916**.

As shown in FIG. 9D, the bedside monitor 916 is capable of simultaneously receiving a first battery and a wireless monitor 902 having a second battery. The bedside monitor 916 is configured to charge and sync both the first and second batteries. When the first battery and/or the wireless monitor 902 and second battery are physically docked in the bedside monitor 916, the first and/or second battery can communicate with the bedside monitor 916 over a wired connection.

The bedside monitor 916 can include a display screen 928 for displaying the physiological parameters, including trends, waveforms, related alarms, and the like. In certain aspects, the bedside monitor 916 can display the appropriate channel for communication and/or whether the wireless monitor 902 is properly communicating with the bedside monitor 916.

The bedside monitor 916 can include a computer-readable storage medium, such as a physical storage device, for storing the physiological data. In certain aspects, the bedside monitor can include a network interface for communicating the physiological data to one or more hosts over a network, such as to a nurse's station computer in a hospital network.

The wireless monitor 902 can transmit data to the bedside monitor 916 using any of a variety of wireless technologies, such as Wi-Fi (802.11x), Bluetooth, ZigBee, cellular telephony, infrared, RFID, satellite transmission, proprietary protocols, combinations of the same, and the like. The wireless monitor 902 can perform solely telemetry functions, such as measuring and reporting information about the patient.

The wireless monitor 902, or any of the wireless monitor embodiments discussed herein, can be configured to utilize different wireless technologies. In certain scenarios, it may be desirable to transmit data over Bluetooth or ZigBee, for example, when the distance between the wireless monitor 902 and the bedside monitor 916 is within range of Bluetooth or ZigBee communication. Transmitting data using Bluetooth or ZigBee is advantageous because these technologies require less power than other wireless technologies. In other scenarios, it may be desirable to transmit data using Wi-Fi or cellular telephony, for example, when the wireless monitor is out of range of communication for Bluetooth or ZigBee. A wireless monitor 902 may be able to transmit data over a greater distance using Wi-Fi or cellular telephony than other wireless technologies. In still other scenarios, it may be desirable to transmit data using a first wireless technology and automatically switch to a second wireless technology in order to maximize data transfer and energy efficiency.

In some embodiments, the wireless monitor 902 automatically transmits data over Bluetooth or ZigBee when the wireless monitor 902 is within a pre-determined distance from bedside monitor 916. The wireless monitor 902 automatically transmits data over Wi-Fi or cellular telephony when the wireless monitor 902 is beyond a pre-determined distance away from the bedside monitor 916. In certain embodiments, the wireless monitor 902 can automatically convert from Bluetooth or ZigBee to Wi-Fi or cellular telephony, and vice versa, depending on the distance between the wireless monitor 902 and bedside monitor 916.

In some embodiments, the wireless monitor 902 automatically transmits data over Bluetooth or ZigBee when the Bluetooth or ZigBee signal strength is sufficiently strong or when there is interference with Wi-Fi or cellular telephony. The wireless monitor 902 automatically transmits data over Wi-Fi or cellular telephony when the Bluetooth or ZigBee signal strength is not sufficiently strong. In certain embodi-

ments, the wireless monitor 902 can automatically convert from Bluetooth or ZigBee to Wi-Fi or cellular telephony, and vice versa, depending on signal strength.

Existing wireless bedside monitoring devices can be difficult to use because it can be difficult to pair the wireless device with the correct bedside monitor, making it difficult to switch wireless devices or switch bedside monitors. Some wireless systems require the care provider to program the wireless device to communicate with the correct patient monitor. Other wireless systems require a separate token or encryption key and several steps to pair the wireless device with the correct bedside monitors. Some systems require the token to be connected to the bedside monitor, then connected to the wireless device, and then reconnected to the bedside monitor.

In certain scenarios, it may be desirable to share wireless communication information between a wireless monitor 902 and a bedside monitor 916 without a separate token or encryption key. In some embodiments, the removable battery 904 includes a data storage component, such as memory 932, capable of storing wireless communication information. The battery 904 is configured to connect to both the wireless monitor 902 and the bedside monitor 916. Combining the battery 904 with a data storage component can decrease the total number of components and decrease the number of steps it takes to transfer wireless communication information between the wireless monitor 902 and bedside monitor 916 because a separate token or encryption key is not needed. This method of data transfer also eliminates user input errors arising from users having to program the wireless monitor 902 and/or bedside monitor 916 and allows for easy transfer of wireless communication information between the wireless monitor 902 and bedside monitor 916.

For security purposes, it may be desirable to use security tokens to ensure that the correct bedside monitor 916 receives the correct wirelessly transmitted data. Security tokens prevent the bedside monitor 916 from accessing the transmitted data unless wireless monitor 902 and bedside monitor 916 share the same password. The password may be a word, passphrase, or an array of randomly chosen bytes.

When the battery 904 is connected to the bedside monitor 916, the bedside monitor 916 can communicate a password to the battery 904, and the battery 904 stores the password on its data storage component. The battery 904 can communicate a password for the wireless monitor 902 to the bedside monitor 916. The battery 904 can then be disconnected from the bedside monitor 916 and connected to the wireless monitor 902. When the battery 904 is connected to the wireless monitor 902, the battery 904 can communicate the password to the wireless monitor 902. The wireless monitor 902 can then communicate wirelessly with the correct bedside monitor 916.

In some scenarios, it may be desirable to pair the wireless monitor 902 with the bedside monitor 916 to avoid interference from other wireless devices. When the removable battery 904 is connected to the bedside monitor 916, the bedside monitor 916 communicates a unique identifier to the battery 904, and the battery 904 stores the unique identifier on its data storage component. The battery 904 can communicate a unique identifier for the wireless monitor 902 to the bedside monitor 916. The battery 904 can then be disconnected from the bedside monitor 916 and connected to the wireless monitor 902. When the battery 904 is connected to the wireless monitor 902, the battery 904 can communicate the unique identifier to the wireless monitor 902, so that the wireless monitor 902 can transmit data to the correct bedside monitor 916.

In some scenarios, it is desirable for the wireless monitor 902 to be configured to transmit data over the correct channel. Channels provide a mechanism to avoid sources of wireless interference. When the removable battery 904 is connected to the bedside monitor 916, the bedside monitor 916 communicates the appropriate channel to the battery 904, and the battery 904 stores the channel information on its data storage component. If necessary, the battery 904 can communicate a wireless monitor channel the bedside monitor 916. The battery 904 is then disconnected from the bedside monitor 916 and connected to the wireless monitor 902. When the battery 904 is connected to the wireless monitor 902, the battery 904 can communicate the appropriate channel information to the wireless monitor 902, thereby ensuring the wireless monitor 902 transmits data over the correct channel.

The battery 904, or any battery embodiment described herein, can receive or communicate any one or combination of passwords, tokens, or channels as described above. The wireless communication information can include information to communicate over each protocol the wireless monitor 902 is configured to communicate over. For example, if the wireless monitor 902 is capable of communicating over Wi-Fi and Bluetooth, then the battery 904 is capable of receiving wireless communication information to communicate over both Wi-Fi and Bluetooth.

In some scenarios, the method in any of the above mentioned methodologies may be reversed. For example, in some embodiments, the battery 904 is initially connected to the wireless monitor 902. When the battery 904 is connected to the wireless monitor 902, the wireless monitor 902 can communicate wireless communication information identifying the wireless monitor 902 to the battery 904, and the battery 904 can store the information on its data storage component. The battery can communicate wireless communication information identifying the bedside monitor 916 to the wireless monitor 902. After the battery 904 is disconnected from the wireless monitor 902, the battery 904 is connected to the bedside monitor 916. The battery 904 can then communicate wireless communication information stored on the data storage component to the bedside monitor 916, such as a password, unique identifier, channel, or other data information.

FIG. 11 illustrates an embodiment for using the wireless patient monitoring system that can be used in connection with any wireless patient monitoring system described herein. The operator connects the removable battery to the bedside monitor (block 1102) and the bedside monitor and the battery communicate wireless communication information with each other (block 1104). The operator then disconnects the battery from the bedside monitor (block 1106) and connects the battery to the wireless monitor (block 1108). The battery and the wireless monitor communicate wireless communication information with each other (block 1110). After the wireless monitor receives data from the one or more sensors (block 1112), the wireless monitor processes the sensor data into representations of physiological parameters (block 1114). The wireless monitor then wireless communicates the physiological parameters and/or the sensor data to the bedside monitor (block 1116).

In some embodiments, the data storage component of the battery 904 stores wireless communication information related to the wireless monitor 902. The wireless communication information can be a password, unique identifier, channel, etc. When the battery 904 is engaged with the bedside monitor 916, the bedside monitor 916 can communicate wireless communication information to the battery

904, and the battery 904 can communicate wireless communication information to the bedside monitor 916. The battery 904 is then disconnected from the bedside monitor 916 and connected to the wireless monitor 902. Since the battery 904 already communicated the wireless communication information to the bedside monitor 916, the battery 904 provides all remaining wireless communication information to the wireless monitor. The wireless monitor reconfigures itself according to the information on the battery and no further information is required to be communicated with the bedside monitor 916. This reduces the total number of steps necessary to pair the wireless monitor 902 with the correct bedside monitor 916.

FIG. 12 illustrates another embodiment of the wireless patient monitor 1202. The features of the wireless patient monitor 1202 can be combined with any of the features of the systems described above. Likewise, any of the features described above can be incorporated into the patient monitor 1202.

As shown in FIG. 12, the wireless patient monitor 1202 can include a housing 1205 that removably engages a battery 1204. The monitor 1202 can include a release mechanism 1212 for releasing the battery 1204 from the housing 1206 and/or one or more outlets 1210 for engaging one or more sensors.

The wireless patient monitor 1202 can include a wireless transceiver capable of transmitting data using any of a variety of wireless technologies, such as Wi-Fi (802.11x), Bluetooth (802.15.2), Zigbee (802.15.4), cellular telephony, infrared, RFID, satellite transmission, proprietary protocols, combinations of the same, and the like.

As shown in FIG. 12, the battery 1204 can include a display screen 1240. The display screen 1240 can indicate any number of parameters, including, but not limited to, physiological parameters, battery levels, and wireless signal strength. Positioning the display screen 1240 on the battery 1204 helps reduce the size of the housing.

The display screen 1240 can include a touch interface to permit a user to access different parameters or settings (e.g., display settings, connectivity settings, etc.). In certain aspects, the display screen 1240 can rotate depending on the orientation of the battery 1204.

To save energy, the display screen 1240 can selectively display certain parameters depending on the location of the battery 1204. For example, if the battery is connected to the bedside monitor or disconnected from the wireless monitor, the battery may only display battery levels. If the battery is connected to the wireless monitor, then the battery may display additional parameters other than battery levels.

The display screen 1240 can selectively display certain parameters depending on the distance between the wireless monitor 1202 and the bedside monitor 1216. Referring to FIG. 13, if the wireless monitor 1202 is within a predetermined distance from the bedside monitor—(block 1300), then the display screen 1240 deactivates (block 1302). If the wireless monitor 1202 is not within a predetermined distance from the bedside monitor (block 1300), then the display screen 1240 initializes (block 1304). The display screen 1240 only needs to be active when the patient is not close to the bedside monitor.

The display screen 1240 can selectively display certain parameters depending on the type of wireless connection between the wireless monitor 1202 and the bedside monitor and/or hospital IT infrastructure. Referring to FIG. 14, if the wireless monitor 1202 wirelessly communicates physiological parameters and/or sensor data over Bluetooth (block 1410), then the display screen deactivates (block 1412). If

the wireless monitor **1202** wirelessly communicates physiological parameters and/or sensor data over Wi-Fi (block **1414**), then the display screen **1240** initializes (block **1416**).

The wireless monitor **1202** can selectively transmit information over different wireless connections and display certain parameters depending on the distance between the wireless monitor **1202** and the bedside monitor. Referring to FIG. **15**, if the wireless monitor **1202** is within a predetermined distance from the bedside monitor (block **1520**), then the wireless monitor **1202** wirelessly communicates physiological parameters and/or sensor data to the bedside monitor over Bluetooth (block **1522**). If the wireless monitor **1202** wirelessly communicates to the bedside monitor over Bluetooth (block **1522**), then the display screen **1240** deactivates (block **1524**). The display screen **1240** does not need to be active since the bedside monitor is nearby.

If the wireless monitor **1202** is not within a predetermined distance from the bedside monitor (block **1520**), then the wireless monitor **1202** wirelessly communicates physiological parameters and/or sensor data to the bedside monitor over Wi-Fi (block **1526**). If the wireless monitor **1202** wirelessly communicates to the bedside monitor over Wi-Fi (block **1526**), then the display screen **1240** initializes (block **1528**). If the wireless monitor **1202** is communicating over Wi-Fi, then it is more likely that the patient is not in the patient room. In that case, it is necessary to have a secondary display screen available to monitor the patient's physiological parameters.

Although FIGS. **14** and **15** were discussed in reference to Bluetooth and Wi-Fi, the system can wirelessly communicate information over ZigBee or cellular telephony. Also, the system may convert from a first wireless technology (e.g., Bluetooth) to a second wireless technology (Wi-Fi) based on signal strength rather than distance.

The wireless monitor **1202** can help the hospital staff monitor the patient when the patient is not close to the bedside monitor. When the patient is close to the bedside monitor, the bedside monitor will notify the staff if any of the patient's physiological parameters are irregular by activating an audible alarm and/or by alerting a staff member using the hospital IT infrastructure. When the patient is more than a pre-determined distance from the bedside monitor, the wireless monitor **1202** can send the physiological parameters and/or sensor data directly over the hospital IT infrastructure, so the hospital staff can continuously monitor the patient at the nurse's station or any other location. If the patient exhibits any irregular physiological parameters, the wireless monitor **1202** can activate an audible alarm and/or alert a staff member using the hospital IT infrastructure. The wireless monitor **1202** can use triangulation to provide the location of the patient, so the staff member can quickly find the patient. By configuring the wireless monitor **1202** to process the sensor data, the wireless monitor **1202** is capable of communicating physiological parameters over the hospital IT infrastructure without the bedside monitor.

Any of the systems described herein can include a display screen and can be configured to carry out any of the methods described in FIGS. **13-15**.

FIGS. **16A-F** illustrate another embodiment of a wireless patient monitoring system. The features of the wireless patient monitoring system can be combined with any of the features of the systems described above. Likewise, any of the features described above can be incorporated into the wireless patient monitoring system.

FIG. **16A** illustrates the wireless monitor **1602** with the battery **1604** detached from the base **1606**. The base **1606** can include processing and wireless transmission capabilities

and/or share processing function with the battery **1604**. The battery **1602** removably engages an anterior surface of the base **1606**. The battery **1602** can engage the housing **1602** via a magnet, a clip, a band, a snap fit, a friction fit, or otherwise. The housing **1602** can include one or more outlets **1610** for engaging one or more sensors **1630**. As shown in FIG. **16A**, the housing **1206** can include an outlet on one end of the housing and another outlet on the opposite end of the housing. Disposing outlets on opposite ends of the housing can be useful to prevent sensor cables from tangling.

The battery **1604** can include a display screen **1640** and a user input device **1644**. The user input device can activate the screen, adjust display settings, select physiological parameters to display, and/or otherwise control the display screen **1640**. As shown in FIG. **16A**, the user input device **1644** can be a touch pad. A user can tap the touch pad to select a feature and/or swipe in different directions to change selections. For example, the user can swipe right or left to change the parameters displayed on the display screen. Other functions can also be performed using the three inputs of the touch pad—left swipe, right swipe, and tap. Other user input devices **1644** can include one or more buttons, switches, or other control. In certain aspects, the display screen can be the user input device.

FIG. **16B** illustrates a strap **1646** for securing the wireless monitor **1602** to the patient. The strap **1646** can include any fabric, elastic, or otherwise flexible material. In certain aspects, the strap **1646** can be waterproof. One or both ends of the strap **1646** can be tapered. One or both ends of the strap **1646** can include a covering to protect the strap ends.

The strap **1646** can be secured to the patient as an arm band, a shoulder strap, a belt, or in any other configuration. A portion of the strap **1646** can be secured to another portion of the strap **1646** using Velcro **1660**, clasps, adhesive, snap-fits, or any other connector. The strap **1646** can include a band (not shown) for securing an excess portion of the strap **1646**.

As shown in FIG. **16B**, the strap **1646** can include a connector **1650** for engaging the wireless monitor **1602** and an adjustment mechanism **1648** to adjust the length of the strap **1646** and/or secure any excess strap **1646**. The connector **1650** can be an integral portion of the strap **1646** or a separately formed component secured to the strap **1646**. As shown in FIG. **16B**, the connector **1650** can include an opening **1656** on opposite sides of the connector **1650** for securing either end of the strap **1646**. One or both ends of the strap **1646** can be removably secured to the connector **1650**.

In certain aspects, the connector **1650** engages the housing by being disposed between the base **1606** and the battery **1604**. At least a portion of the connector **1650** can overlay a portion of the housing. The connector **1650** can include certain features to mate with a corresponding feature of the base **1606** and/or battery **1604**. For example, the connector **1650** can include one or more recesses **1652** configured to mate with one or more protrusions **1658** on the base **1606**. As shown in FIG. **16C**, the connector **1650** can include a recess **1652** on opposite ends of the connector **1650** that mate with protrusions **1658** on opposite ends of the base **1606**. The connector **1650** can be flush with the protrusions **1658** to provide a flat surface for the battery **1604**.

In other aspects, the connector **1650** can pass through an opening of the wireless monitor. For example, as shown in FIG. **12**, the wireless monitor can include an opening **1208** for engaging the strap **1646**. In still other aspects, the connector **1650** can engage the wireless monitor **1602** using clips, ties, buckles, buttons, or any other connector.

The wireless monitor **1602** can include a wireless transceiver capable of transmitting data using any of a variety of wireless technologies, such as Wi-Fi (802.11x), Bluetooth (802.15.2), Zigbee (802.15.4), cellular telephony, infrared, RFID, satellite transmission, proprietary protocols, combinations of the same, and the like.

FIGS. **16D-16F** illustrate a bedside monitor **1616** configured to receive the wireless monitor **1602**. The bedside monitor can include one or more input ports **1627** configured to receive cables. In certain aspects, the bedside monitor **1616** can include a port **1617** configured to receive a handheld device, such as the handheld monitor **166** shown in FIG. **1D**. Further details about the handheld device can be found in U.S. application Ser. No. 13/651,167, filed Oct. 12, 2012, entitled "Medical Monitoring Hub," which is hereby incorporated by reference in its entirety.

The port **1617** can removably engage an adapter **1618**. For example, the adapter **1618** can include a release mechanism **1626** to release the adapter **1618** from the port **1617**. In certain aspects, the release mechanism **1626** is studded, so a user must use one or more tools to release the release mechanism **1626**.

The adapter **1618** can be configured to receive a battery **1604** and/or a wireless monitor **1602**. The adapter **1618** can include a docking adaptor door **1620** configured to receive the stand alone battery **1604** and/or and a port for receiving a the wireless monitor **1602** including a battery **1604**. In certain aspects, as shown in FIG. **16F**, the docking adaptor door **1620** can pivot to facilitate insertion and removal of the wireless monitor **1602**. When the battery **1604** and/or wireless monitor **1602** having a battery **1604** is physically connected to the adapter **1618**, the batteries **1606** can charge and can communicate and/or receive information from the bedside monitor **1616** over a wired connection.

FIGS. **17A-17C** illustrate another embodiment of a wireless monitor **1702**. The wireless monitor **1702** can include any of the other wireless monitor features described herein. Likewise, any of the other wireless monitor embodiments discussed herein can include any of the features of the wireless monitor **1702**.

The wireless monitor **1702** can include a battery **1704** removably engaged with a base **1706**. The base **1706** can include processing and wireless transmission capabilities and/or share processing function with the battery **1704**. FIG. **17A** illustrates an exploded view of the wireless monitor **1702**. The housing can include one or more outlets **1710** configured to connect to one or more sensors (not shown). The battery can include a display **1740** capable of displaying physiological parameters, connectivity information, and/or other content. The battery **1704** can include a touch pad **1744** or other user input device. The touch pad **1744** can permit the user to swipe right, swipe left, or tap to control the wireless monitor **1702**. The battery **1704** can include an additional user input device (e.g., button **1745**) that can activate/deactivate the wireless monitor or provide other functionality.

The battery can include one or more protrusions, ribs, struts, detents, or the like configured to be received in corresponding grooves, notches, recesses, openings, or the like in the base **1706**. FIG. **17B** illustrates views of an inner portion of the battery **1704** and an inner portion of the housing. The battery **1704** can include two protrusions **1741** on each end of the battery **1704** and along an inner portion of the battery **1704**. One or more of the protrusions **1741** can be a different size or shape from the other protrusions **1741**. The base **1706** can include two grooves **1743** on each end of the base **1706** and along an inner portion of the base **1706**.

Each of the grooves **1743** can be configured to receive one of the protrusions **1741**. One or more of the grooves **1743** can be a different size or shape from the other grooves **1743**. FIG. **17C** illustrates a perspective view of the battery **1704** engaged with the base **1706**.

The wireless monitor **1702** can include a wireless transceiver capable of transmitting data using any of a variety of wireless technologies, such as Wi-Fi (802.11x), Bluetooth (802.15.2), Zigbee (802.15.4), cellular telephony, infrared, RFID, satellite transmission, proprietary protocols, combinations of the same, and the like.

As described above, any of the wireless monitoring systems described herein can include an accelerometer or gyroscope that can be used to detect one or more of patient orientation, patient movement, whether the patient is falling, or the like. In certain aspects, the wireless monitoring system can include an alert system to alert the care giver that the patient is falling, getting out of bed, or otherwise moving in a prohibited manner. The alert can be an audible and/or visual alarm on the monitoring system or transmitted to a caregiver (e.g., nurses' station, pager, home computer, or otherwise).

In certain aspects, the information received by the accelerometer or gyroscope can be used to create an indication and/or animation of patient movement. This animation can be displayed on the patient monitor or transmitted to a nurses station or other off-site location to enable the care giver to monitor the patient. The animation can be viewed real time and/or be recorded for playback. For example, if an alarm alerts the care giver that the patient has fallen out of bed, the care giver can be presented playbacks of one or more of the patient's movement during that period of time.

FIGS. **18A-18C** illustrate examples of the animation that can be displayed on a bedside monitor, nurses' station monitor, or other display screen. FIG. **18A** illustrates a patient lying in bed **1801**, and the patient rolling over **1803**. FIG. **18B** illustrates the patient lying in bed **1805**, and the patient sitting up **1807**. FIG. **18C** illustrates the patient lying in bed **1809**, and the patient getting out of bed **1811**. Other patient movements can also be illustrated, such as a patient falling, walking, or otherwise. Depending on the embodiment, certain acts, events, or functions of any of the methods described herein can be performed in a different sequence, can be added, merged, or left out altogether (e.g., not all described acts or events are necessary for the practice of the method). Moreover, in certain embodiments, acts or events can be performed concurrently, e.g., through multi-threaded processing, interrupt processing, or multiple processors, rather than sequentially.

The various illustrative logical blocks, modules, circuits, and algorithm steps described in connection with the embodiments disclosed herein can be implemented as electronic hardware, computer software, or combinations of both. To clearly illustrate this interchangeability of hardware and software, various illustrative components, blocks, modules, circuits, and steps have been described above generally in terms of their functionality. Whether such functionality is implemented as hardware or software depends upon the particular application and design constraints imposed on the overall system. The described functionality can be implemented in varying ways for each particular application, but such implementation decisions should not be interpreted as causing a departure from the scope of the disclosure.

The various illustrative logical blocks, modules, and circuits described in connection with the embodiments disclosed herein can be implemented or performed with a general purpose processor, a digital signal processor (DSP),

an application specific integrated circuit (ASIC), a field programmable gate array (FPGA) or other programmable logic device, discrete gate or transistor logic, discrete hardware components, or any combination thereof designed to perform the functions described herein. A general purpose processor can be a microprocessor, but in the alternative, the processor can be any conventional processor, controller, microcontroller, or state machine. A processor can also be implemented as a combination of computing devices, e.g., a combination of a DSP and a microprocessor, a plurality of microprocessors, one or more microprocessors in conjunction with a DSP core, or any other such configuration.

The steps of a method or algorithm described in connection with the embodiments disclosed herein can be embodied directly in hardware, in a software module executed by a processor, or in a combination of the two. A software module can reside in RAM memory, flash memory, ROM memory, EPROM memory, EEPROM memory, registers, hard disk, a removable disk, a CD-ROM, or any other form of storage medium known in the art. An exemplary storage medium is coupled to the processor such the processor can read information from, and write information to, the storage medium. In the alternative, the storage medium can be integral to the processor. The processor and the storage medium can reside in an ASIC. The ASIC can reside in a user terminal. In the alternative, the processor and the storage medium can reside as discrete components in a user terminal.

Conditional language used herein, such as, among others, “can,” “may,” “might,” “could,” “e.g.,” and the like, unless specifically stated otherwise, or otherwise understood within the context as used, is generally intended to convey that certain embodiments include, while some embodiments do not include, certain features, elements and/or steps. Thus, such conditional language is not generally intended to imply that features, elements and/or steps are in any way required for one or more embodiments or that one or more embodiments necessarily include logic for deciding, with or without author input or prompting, whether these features, elements and/or steps are included or are to be performed in any particular embodiment.

While the above detailed description has shown, described, and pointed out novel features as applied to various embodiments, it will be understood that various omissions, substitutions, and changes in the form and details of the device or process illustrated can be made without departing from the spirit of the disclosure. As will be recognized, certain embodiments of the inventions described herein can be embodied within a form that does not provide all of the features and benefits set forth herein, as some features can be used or practiced separately from others. The scope of the inventions is indicated by the appended claims rather than by the foregoing description. All changes which come within the meaning and range of equivalency of the claims are to be embraced within their scope.

What is claimed is:

1. A wireless patient monitoring system comprising: one or more optical sensors configured to obtain physiological information;

a wireless monitor configured to receive the physiological information and to wirelessly transmit physiological data reflective of the physiological information to a bedside monitor, and

a removable battery, the removable battery including a data storage component that receives communication configuration data from a bedside monitor when physically connected to the bedside monitor and transmits the communication configuration data to the wireless monitor when the removable battery is physically connected to the wireless monitor in order to facilitate communication between the wireless monitor and a bedside monitor,

wherein the wireless monitor accesses the data storage component when the battery is connected to the wireless monitor and reconfigures wireless communication parameters of the wireless monitor according to the communication configuration data.

2. The wireless patient monitoring system of claim 1, wherein the data storage component is configured to store information communicated from the bedside monitor.

3. The wireless patient monitoring system of claim 1, wherein the wireless monitor is configured to be coupled to an arm band attached to the patient.

4. The wireless patient monitoring system of claim 1, wherein the bedside monitor is configured to receive the removable battery.

5. The wireless patient monitoring system of claim 1, wherein the bedside monitor is configured to receive the wireless monitor.

6. The wireless patient monitoring device of claim 1, wherein the wireless monitor is configured to automatically transmit physiological data over a first wireless technology when a signal strength of the first wireless technology allows physiological data to be transmitted over the first wireless technology and automatically transmit physiological data over a second wireless technology when a signal strength of the first wireless technology does not allow the physiological data to be transmitted over the first wireless technology.

7. The wireless patient monitoring device of claim 1, wherein the wireless monitor is configured to transmit physiological data over a first wireless technology when the wireless monitor and the bedside monitor are within a range that allows wireless communication over the first wireless technology and transmit physiological data over a second wireless technology when the wireless monitor and the bedside monitor are not within the range that allows wireless communication over the first wireless technology.

8. The wireless patient monitoring device of claim 1, wherein the removable battery includes a display.

9. The wireless patient monitoring device of claim 8, wherein the display is configured to activate when the wireless monitor transmits physiological data over a first wireless technology and deactivate when the wireless monitor transmits physiological data over a second wireless technology.

\* \* \* \* \*

专利名称(译)	无线患者监护设备		
公开(公告)号	<a href="#">US10149616</a>	公开(公告)日	2018-12-11
申请号	US13/762270	申请日	2013-02-07
[标]申请(专利权)人(译)	梅西莫股份有限公司		
申请(专利权)人(译)	Masimo公司		
当前申请(专利权)人(译)	Masimo公司		
[标]发明人	AL ALI AMMAR KINAST ERIC KARL MUHSIN BILAL DEJONG CHAD A		
发明人	AL-ALI, AMMAR KINAST, ERIC KARL MUHSIN, BILAL DEJONG, CHAD A.		
IPC分类号	A61B6/00 A61B5/00 A61B5/1455 A61B5/024		
CPC分类号	A61B5/0024 A61B5/002 A61B5/0022 A61B5/0059 A61B5/14551 A61B5/7445 A61B5/02416 A61B2560/0475 A61B2560/0214 A61B2560/0266 G16H10/60 G16H40/20 G16H40/63 A61B5/0261 A61B5/0295 A61B5/14552 A61B5/6826 A61B5/6831 A61B5/6833 A61B5/725 A61B5/7405 A61B5/7425 A61B5/746		
助理审查员(译)	WOO , JAE		
优先权	61/703713 2012-09-20 US 61/625584 2012-04-17 US 61/597126 2012-02-09 US		
其他公开文献	US20130253334A1		
外部链接	<a href="#">Espacenet</a>		

摘要(译)

一种用于获得医疗患者的生理信息并将获得的生理信息无线发送到无线接收器的设备。

